

Honeywell

THE POWER OF **CONNECTED**

CN75/CN75e NI

with Windows® Embedded Handheld 6.5

Quick Start Guide



CN75NI-W65-EN-QS-0 Rev A
5/17

Introduction

This document is for the CN75/CN75e NI. This is the non-incendive version of the CN75/CN75e. The CN75/CN75e NI can be identified by the device label verifying non-incendive certification.



Warning: Explosion Hazard -Substitution of components may impair suitability for Division 2 Class I, II, III locations.

Avertissement: Risque d' explosion - Le remplacement de composants risque de compromettre l'adaptation du produit aux sites de division 2 catégorie I,II,III.

Out of Box

Make sure that your shipping box contains these items:

- CN75/CN75e NI mobile computer (Model CN75LAN or CN75WAN)
- Rechargeable 3.7 V, Lithium-ion battery
- I/O Cover
- Product Documentation

If you ordered accessories for your mobile computer, verify that they are also included with the order. Be sure to keep the original packaging in case you need to return the mobile computer for service.

Note: *CN75LAN models do not include a WWAN radio.*

Memory Card Specifications

Honeywell recommends the use of Single Level Cell (SLC) industrial grade microSD™ memory cards with the computer for maximum performance and durability. Contact a Honeywell sales representative for additional information on qualified memory card options.

Computer Features

Note: Hand strap not shown.

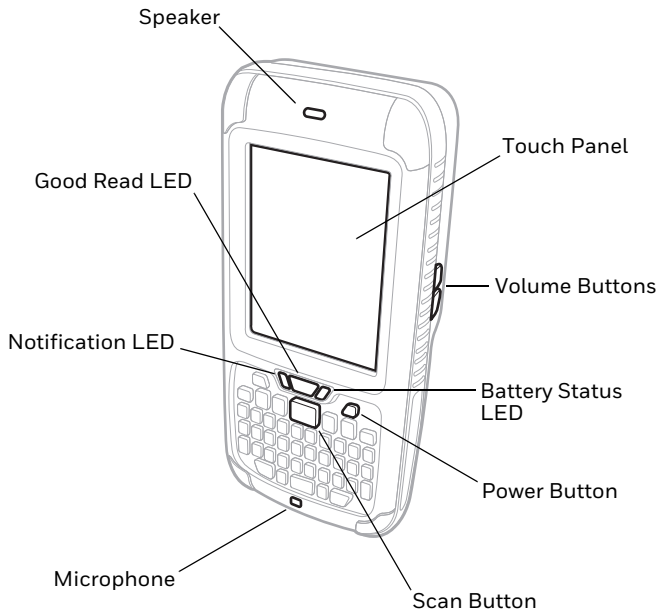

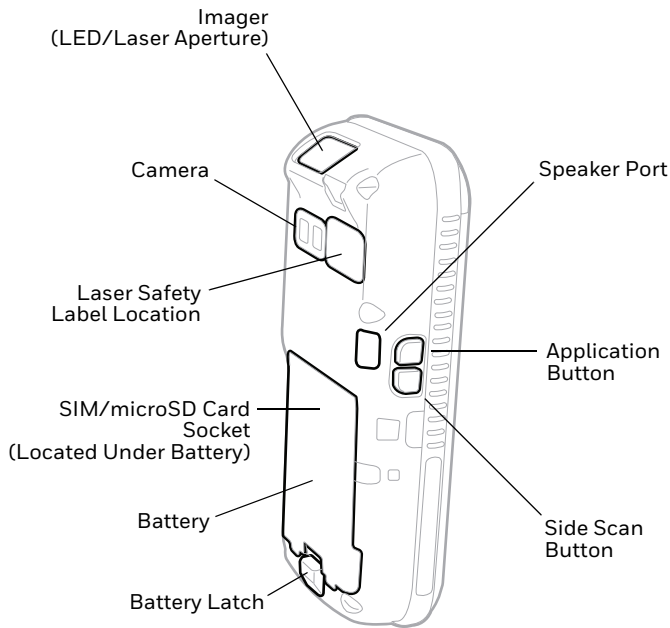

I/O Cover

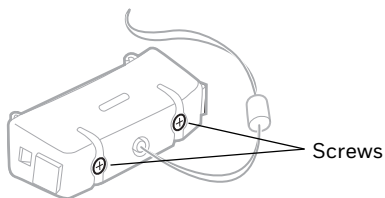

Detach Hand Strap

Detach the hand strap to access to the back of the computer.

Note: *Battery pack shown installed. To learn more, see “[Install the Battery](#)”.*

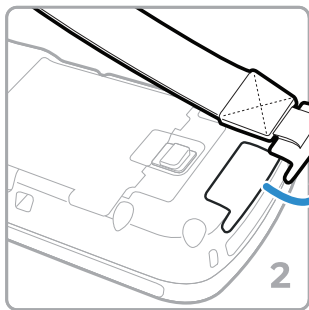
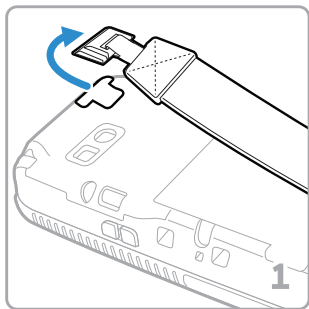

Install a microSD Card

Note: Format the microSD card before initial use.

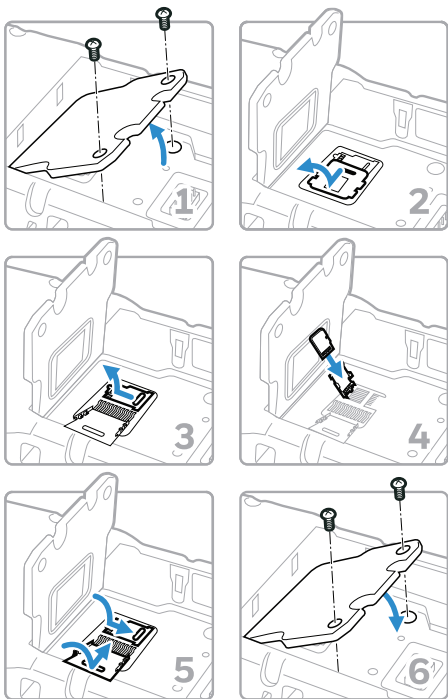

Note: Always place the computer in hibernate mode and remove the battery before attempting to install or remove a card.

Install a SIM Card

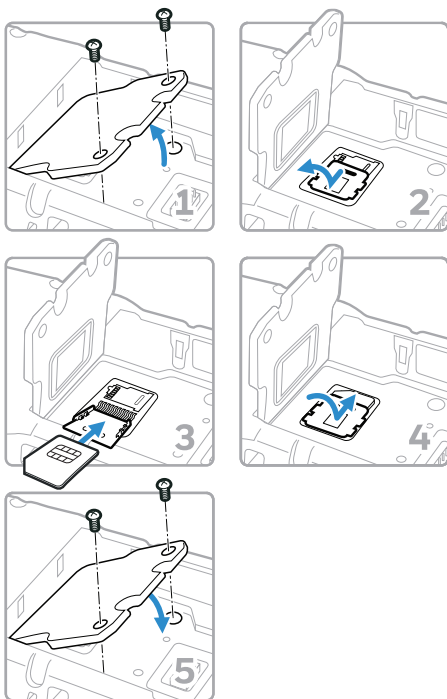

Note: Always place the computer in hibernate mode and remove the battery before attempting to install or remove a card.

Install the Battery

The CN75/CN75e NI mobile computer ships with a Lithium-ion 3.7 V, 4000 mAH (14.8 Wh) battery manufactured for Honeywell International Inc.



We recommend use of Honeywell Li-ion battery packs. Use of any non-Honeywell battery may result in damage not covered by the warranty.

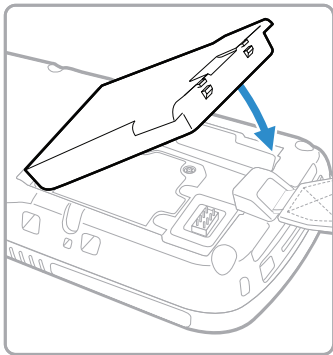

Ensure all components are dry prior to placing the battery in the computer. Mating wet components may cause damage not covered by the warranty.

Charge the Computer



Warning: Explosion Hazard - Batteries must only be changed or charged in an area known to be non-hazardous. Use ONLY Honeywell CN75 NI battery part number 1000AB02.

Risqué d'explosion—Les batteries doivent uniquement être remplacées ou rechargées dans un endroit non dangereux. Utilisez UNIQUEMENT Honeywell CN75 NI batterie P/N 1000AB02

The CN75/CN75e NI mobile computer ships with a partially charged battery. Charge the battery with a 70 Series charging device for a minimum of **6 hours**.

Using the computer while charging the battery increases the time required to reach a full charge. If the CN75/CN75e is drawing more current than supplied by the charging source, charging will not take place. For additional information, see the user guide.



We recommend the use of Honeywell peripherals, power cables and power adapters. Use of any non-Honeywell accessories or power adapters may cause damage not covered by the warranty.

CN75/CN75e NI mobile computers are designed for use with the following charging accessories: DX1 Desktop Dock, DX2 Dual Dock, and DX4 Quad Dock and a power supply.



Ensure all components are dry prior to mating the computers and batteries with peripheral devices. Mating wet components may cause damage not covered by the warranty.

Install the I/O Cover



The I/O cover must be attached when using the CN75/CN75e NI in a dangerous environment.

Avertissement : Le couvercle entrée-sortie doit être fixé lorsque le CN75/CN75e NI est utilisé dans un environnement incendiaire.

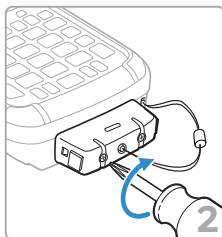
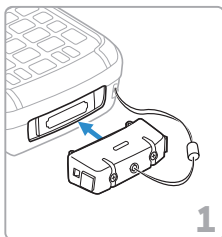

Remove the I/O Cover

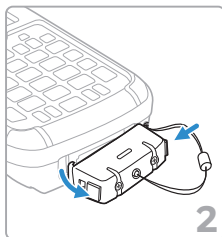
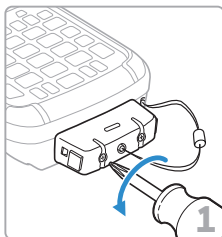

Turn Power On

The computer automatically turns on when you install the battery pack.

Suspend Mode (Sleep Mode)

Suspend mode automatically turns off all radios and internal devices not involved in saving the system state to save battery power when the computer is inactive for a programmed period of time.

- Press and release the **Power** button to wake the computer.

To manually activate suspend mode:

1. Press and hold the **Power** button until the options menu appears.
2. Touch **Suspend**.

Note: To adjust the time out limit, touch **Settings** > **Power**. Select the **Advanced** tab.

Use Hibernate Mode for Battery Removal

You should always place the computer in hibernate mode before removing the battery. Hibernate mode places the computer in a low power state so that the battery can be removed for a short period of time.

To activate hibernate mode:

1. Press and hold the **Power** button until the options menu appears.
2. Touch **Hibernate**.
3. After replacing the battery, press and release the **Power** button to wake the device.

About the Home Screen

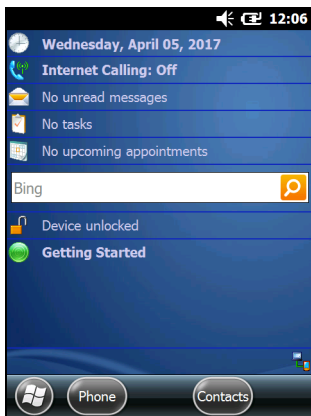



— Title Bar
(Notification /
Status Bar)



— Search Bar

} Tile Bar

Touch to access the Start menu.

Navigation and Function Buttons

Buttons	Description	Function
	Up, Down, Left and Right	Move up, down, right or left on the screen.
	Scan	Trigger the scanner.

Buttons	Description	Function
	Modifiers	Press a modifier key before pressing another key to access an alternate key value or function. Alternate key values appear on the keypad overlay near the relevant key. Modifier key shape and availability depend on keypad model types.
	Volume	Raise (top button) or lower (bottom button) the volume of the speaker.
	App and Scan	Press the application button (top) to open the Notes app and the scan button (bottom) to trigger the scanner.

To learn more about how to use the keypad for your computer model and remap a button function, see the user guide.

Scan a Bar Code

Note: For optimum performance, avoid reflections by scanning the bar code at a slight angle.

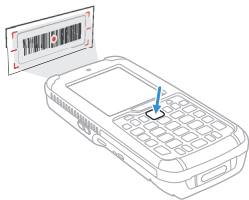

1. Point the computer at the bar code.
2. Touch and hold the **Scan** button.
3. Center the aiming beam over the bar code. When the scanner successfully reads the bar code, the computer beeps, and the Good Read LED briefly turns on. The bar code information is entered into the application in use.
4. Release the **Scan** button.

Sync Data

To sync files between your CN75/CN75e and computer:

1. If you have a computer running Windows® 10, open the Phone Companion app from **Start > All apps**.

If you have a computer running Windows 8 or Windows 8.1, the Windows Phone® app automatically opens when you connect the CN75/CN75e NI to the computer using a USB charge/communication cable.

If you have a computer running Windows 7 or Mac, go to www.windowsphone.com to download and install the Windows Phone app for desktop or Mac.

2. In the Phone Companion app, select **Windows** as your terminal platform, and then set your sync preferences.

In the Windows Phone app, set your phone name and sync preferences. You can always modify your preferences later by selecting **Settings**.

To move files between your CN75/CN75e and computer without using the Phone Companion or Windows Phone app:

1. Connect the CN75/CN75e to your computer using a USB charge/communication accessory.
2. Depending on the Windows operating system, either open **File Explorer** or **Windows Explorer**.
3. Under “Computer” or “This PC”, click on the CN75/CN75e. You can now copy, delete and/or move files or folders between the computer and the CN75/CN75e or a microSD card installed in the CN75/CN75e as you would with any other storage drive (e.g., cut and paste or drag and drop).

Restart the Computer

You may need to restart the mobile computer to correct conditions where an application stops responding to the system or the computer seems to be locked up.

1. Press and hold the **Power** button until the options menu appears.
2. Select **Reboot** and then **OK**.

To restart the computer if the touch panel display is unresponsive:

- Press and hold the **Power** button for approximately 8 seconds until the computer restarts.

Note: *If you try to restart the computer and still experience issues, you may need to see the user guide for information on how to perform a Factory Reset (Clean Boot).*

Support

To search our knowledge base for a solution or log into the Technical Support portal and report a problem, go to www.hsmcontactsupport.com.

User Documentation

For the user guide and other documentation, go to www.honeywellaidc.com.

Limited Warranty

For warranty information, go to www.honeywellaidc.com and click **Get Resources > Product Warranty**.

Patents

For patent information, see www.hsmpats.com.

Trademarks

Microsoft, Windows, Windows Phone, File Explorer, Windows Explorer and the Windows logo are either registered trademarks or registered trademarks of Microsoft Corporation in the United States and/or other countries.

Mac is a trademark of Apple Inc.

Disclaimer

Honeywell International Inc. (“HII”) reserves the right to make changes in specifications and other information contained in this document without prior notice, and the reader should in all cases consult HII to determine whether any such changes have been made. The information in this publication does not represent a commitment on the part of HII.

HII shall not be liable for technical or editorial errors or omissions contained herein; nor for incidental or consequential damages resulting from the furnishing, performance, or use of this material. HII disclaims all responsibility for the selection and use of software and/or hardware to achieve intended results.

This document contains proprietary information that is protected by copyright. All rights are reserved. No part of this document may be photocopied, reproduced, or translated into another language without the prior written consent of HII.

Copyright © 2017 Honeywell International Inc. All rights reserved.

Free Manuals Download Website

<http://myh66.com>

<http://usermanuals.us>

<http://www.somanuals.com>

<http://www.4manuals.cc>

<http://www.manual-lib.com>

<http://www.404manual.com>

<http://www.luxmanual.com>

<http://aubethermostatmanual.com>

Golf course search by state

<http://golfingnear.com>

Email search by domain

<http://emailbydomain.com>

Auto manuals search

<http://auto.somanuals.com>

TV manuals search

<http://tv.somanuals.com>