

Honeywell

CONTACTORS

THESE SPST AND DPST ELECTROMAGNETICALLY OPERATED CONTACTORS PROVIDE SWITCHING FOR ACROSS-THE-LINE STARTING OF INDUCTION MOTORS AS USED IN HERMATIC REFRIGERATION COMPRESSORS OR FOR SWITCHING ELECTRIC RESISTANCE HEATERS.

- The contactors are rated up to 600 Vac, per pole, up to 30 A inductive, and up to 40 A resistive load.
- Spst models provide single line break start of induction motors for air conditioning or refrigeration manufacturers.
- Optional jumper strap with two No. 10 screws for line or load connection and two double quick-connect accessory terminals.
- Convenient interchangeable mounting with most competitive devices. Single screw mounting possible with shear formed tab in panel.
- Bridge type, double break, heavy duty silver alloy contacts pick up and open without chattering when slowly rising or slowly decreasing voltage is applied to operating coil.
- Contact terminals have No. 10 binding screws for load connections, and terminal clamp screws for line connections. Two NEMA type 1/4 inch [6.4 mm] quick-connects are provided for accessory connections.
- Optional terminals clamp screw assemblies or pressure lugs.

R4242A,C
R8242A,C
R4243A
R8243A

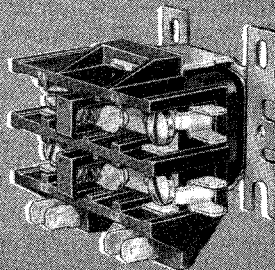
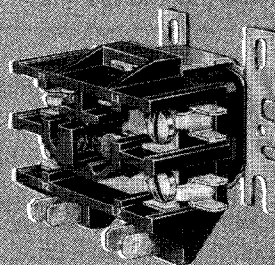

R4242B
R8242B
R4243B
R8243B

**R4242A,B,C;
R4243A,B;
R8242A,B,C;
R8243A,B**

SPECIFICATIONS

IMPORTANT

THE SPECIFICATIONS ARE GIVEN IN THIS PUBLICATION DO NOT INCLUDE NORMAL MANUFACTURING TOLERANCES. THEREFORE, THIS UNIT MAY NOT MATCH THE LISTED SPECIFICATIONS EXACTLY. ALSO, THIS PRODUCT IS TESTED AND CALIBRATED UNDER CLOSELY CONTROLLED CONDITIONS, AND SOME MINOR DIFFERENCES IN PERFORMANCE CAN BE EXPECTED IF THOSE CONDITIONS ARE CHANGED.

SUPER TRADELINE MODELS

SUPER TRADELINE models are selected and packaged to provide ease of stocking, ease of handling, and maximum replacement value. SUPER TRADELINE model specifications are the same as those of standard models except as noted below.

SUPER TRADELINE MODELS AVAILABLE:

- R4242B Contractor—30 A, line voltage coil.
- R4243B Contractor—30 A, low voltage coil.
- Special models available with 35 AFL, 150 ALR rating at 240/277 Vac.

TERMINALS: R4243B and R8243B have terminal clamp screws (accept up to No. 8 AWG wire) for both line and load connections.

ADDITIONAL FEATURES: SUPER TRADELINE pack with cross reference label, 138550 Mounting Adapter Plate, two 12 inch [304.8 mm] coil lead wires with quick-connects on one end and stripped on other end, 2 wire nuts, six 1/4 inch [6.4 mm] female quick-connects, 2 mounting screws, and special instruction sheet.

STANDARD MODELS

MODELS^a:

Spst Models—

- R4242A Contractor—25 A, line voltage coil.
- R4242C Contractor—23 A, line voltage coil.
- R4243A Contractor—30 A, line voltage coil.
- R8242A Contractor—25 A, low voltage coil.
- R8242C Contractor—23 A, low voltage coil.
- R8243A Contractor—30 A, low voltage coil.

Dpst Models—

- R4242B Contractor—20 A, line voltage coil.
- R8242B Contractor—20 A, low voltage coil.
- R4243B Contractor—30 A, line voltage coil.
- R8243B Contractor—30 A, low voltage coil.

^aFor additional specifications see Tables I, II and III.

CONTACTS: Heavy duty, silver alloy, bridge type, double break contacts. The 20, 23, and 25 A models have

composite contacts; 30 A models have solid silver alloy terminal contacts.

COIL CONNECTIONS: Male, double quick-connects standard on all models.

DIMENSIONS: See Figs. 1-3.

LINE CONNECTIONS:

Spst models—Tin-plated, brass terminals with No. 10 binding head screws (accept up to No. 10 AWG wire) on load side, and terminal clamp screws (accept up to No. 8 AWG wire) on line side.

Dpst models—Tin-plated, brass terminals with No. 10 binding head screws (accept up to No. 10 AWG wire) on load side, and terminal clamp screws (accept up to No. 8 AWG wire) on line side.

NOTE: To meet UL 508 requirements, the pressure lug option or accessory must be used for field wiring connections of No. 8 through No. 4 AWG wire.

(continued on page 3)

ORDERING INFORMATION

WHEN PURCHASING REPLACEMENT AND MODERNIZATION PRODUCTS FROM YOUR TRADELINE WHOLESALE OR YOUR DISTRIBUTOR, REFER TO THE TRADELINE CATALOG OR PRICE SHEETS FOR COMPLETE ORDERING NUMBER, OR SPECIFY—

1. Order Number, SUPER TRADELINE if desired.
2. Contact ratings.
3. Coil ratings.
4. Optional specifications, if desired.

IF YOU HAVE ADDITIONAL QUESTIONS, NEED FURTHER INFORMATION, OR WOULD LIKE TO COMMENT ON OUR PRODUCTS OR SERVICES, PLEASE WRITE OR PHONE:

1. YOUR LOCAL HONEYWELL RESIDENTIAL SALES OFFICE (CHECK WHITE PAGES OF YOUR PHONE DIRECTORY).
2. RESIDENTIAL DIVISION CUSTOMER SERVICE
HONEYWELL INC., 1885 DOUGLAS DRIVE SOUTH
MINNEAPOLIS, MINNESOTA 55422-4386 (612)542-7500

(IN CANADA—HONEYWELL LIMITED/HONEYWELL LIMITEE, 740 ELLESMERE ROAD, SCARBOROUGH, ONTARIO M1P 2V9) INTERNATIONAL SALES AND SERVICE OFFICES IN ALL PRINCIPAL CITIES OF THE WORLD.

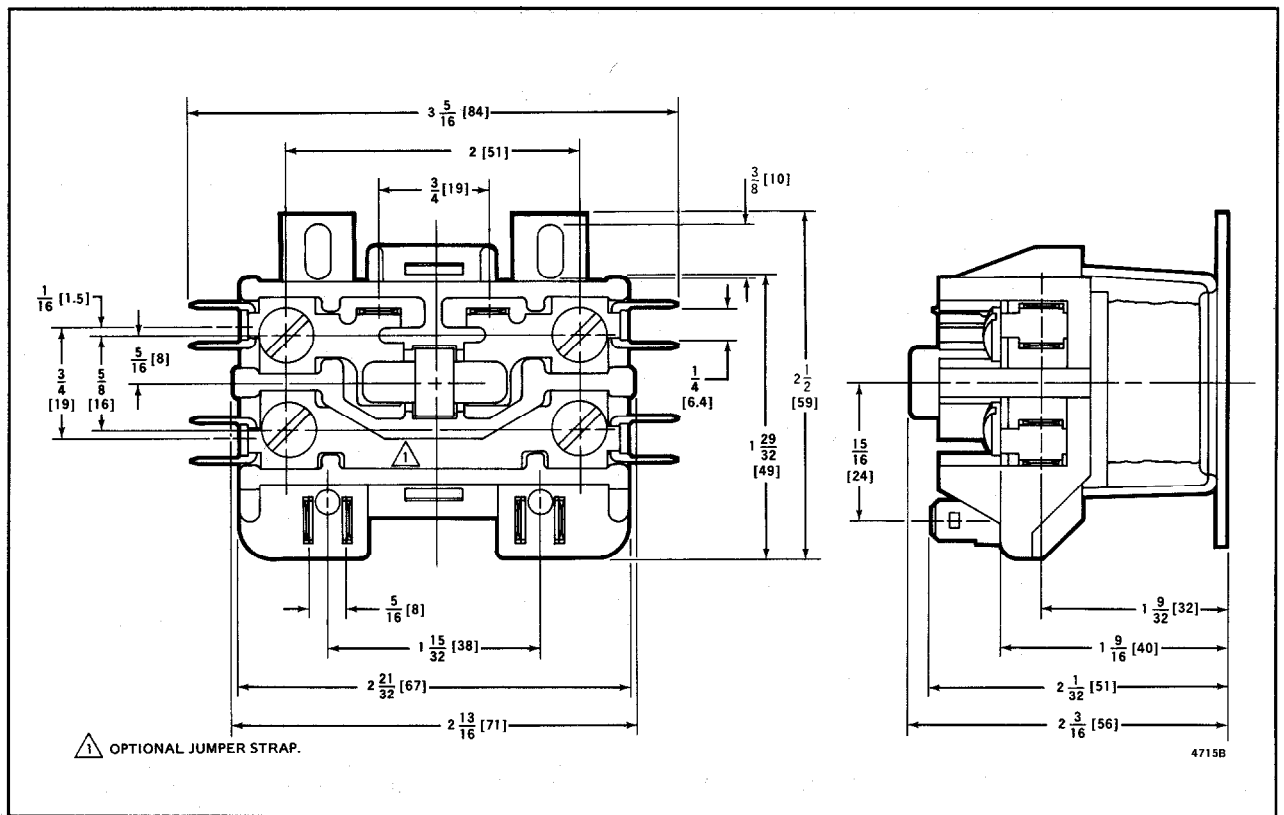

FIG. 1—DIMENSIONS OF R4242A,C; R4243A; R8242A,C; AND R8243A CONTACTORS, IN in. [mm IN BRACKETS].

ACCESSORY TERMINALS: Contactor quick-connect accessory terminals are intended for OEM use such as in wiring tie points, pilot duty circuits, condenser fans, crankcase heaters or other light inductive loads. If an OEM chooses to utilize our accessory terminals in other than their intended usage, we can only suggest that the OEM use extreme care in performing adequate testing and in selection and application of the female quick-connect.

MOUNTING MEANS: Two screws (up to No. 10 size) through holes in base or may be mounted on shear formed panel. See Fig. 4.

CONTACTOR TERMINAL BLOCK:

20 A Models—single piece, black molded phenolic provides good arc resistance and strength.

23, 25, and 30 A Models—single piece, brown molded melamine phenolic provides high arc resistance and strength.

CONTACT RATINGS: See Table 1.

COIL RATINGS: See Table 2, 3. All coils meet Underwriters Laboratories Inc. requirements for Class B coils. If a 480 V or 600 V coil is desired, contact your local Honeywell representative for additional information.

AMBIENT TEMPERATURE RANGE: -20° F to +155° F [-29° C to +68° C].

UNDERWRITERS LABORATORIES INC. COMPONENT RECOGNIZED: File No. E59779, Guide No. NLDX2.

CANADIAN STANDARDS ASSOCIATION CERTIFIED: File No. LR35066, GUIDE NO. 361E0.2.

OPTIONAL PARTS AND ACCESSORIES:

1. Jumper strap with 2 screw terminals and 4 accessory quick-connects, for spst models only. See Fig. 1.
2. 138550 Mounting Adapter Plate—to adapt contactors to competitive mounting dimensions.
3. 138552B Enclosure. See Fig. 4.

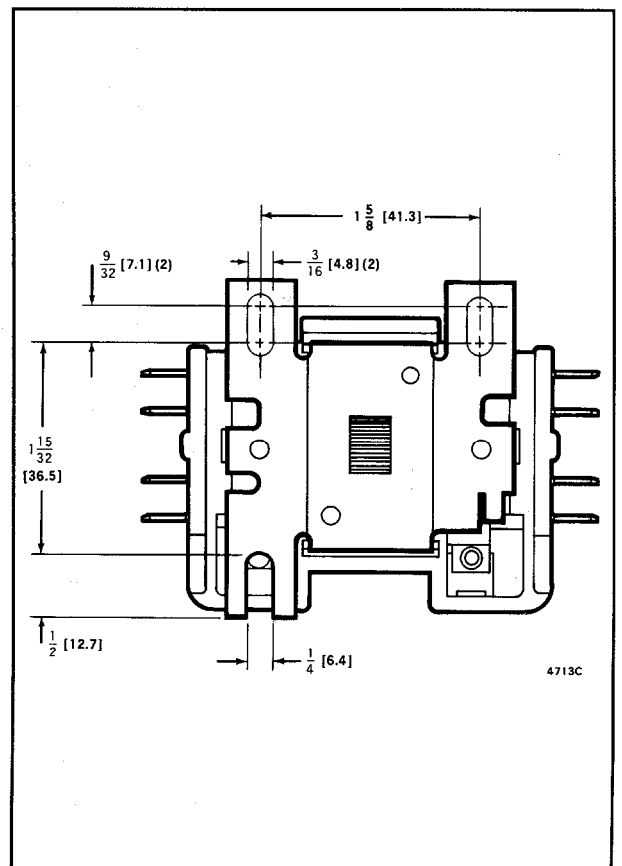

FIG. 2—DIMENSIONS OF CONTACTOR BASE, IN in. [mm IN BRACKETS].

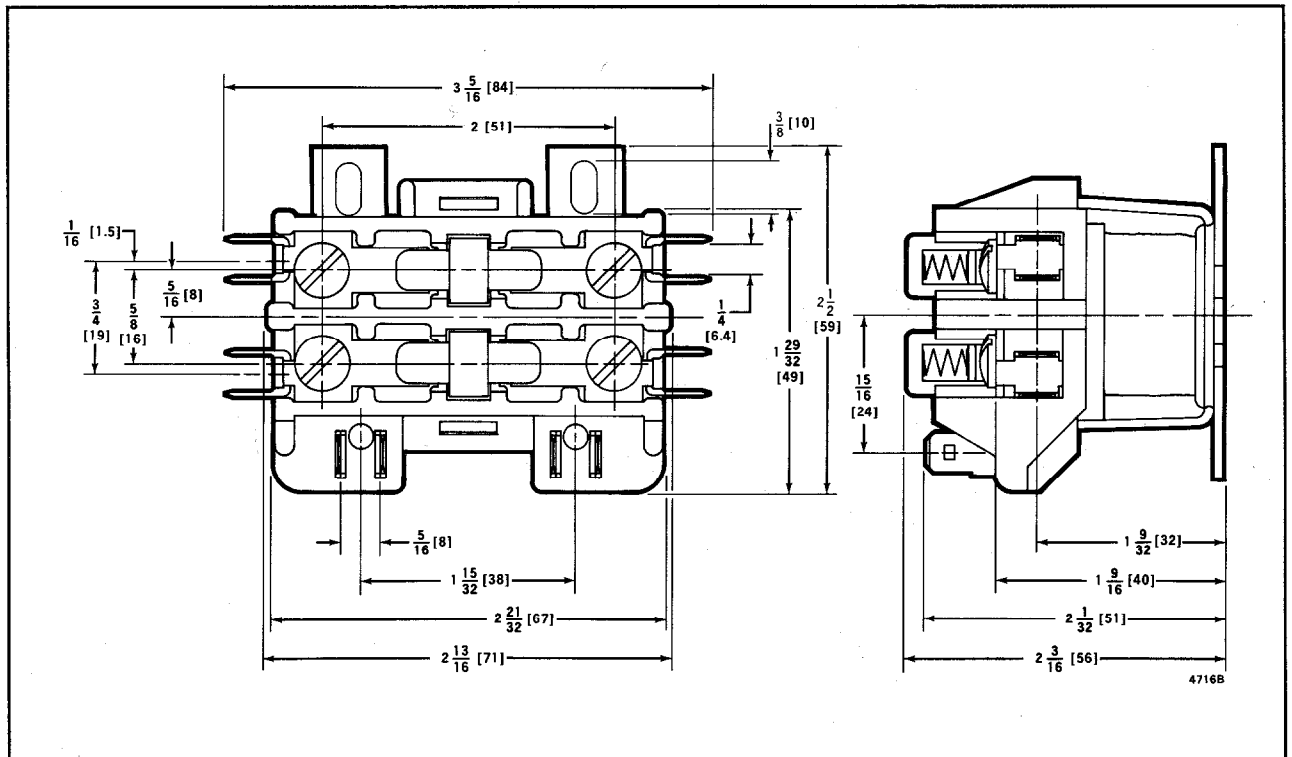

FIG. 3—DIMENSIONS OF R4242B, R8242B, R4243B, AND R8243B DPST CONTACTORS, IN in. [mm IN BRACKETS].

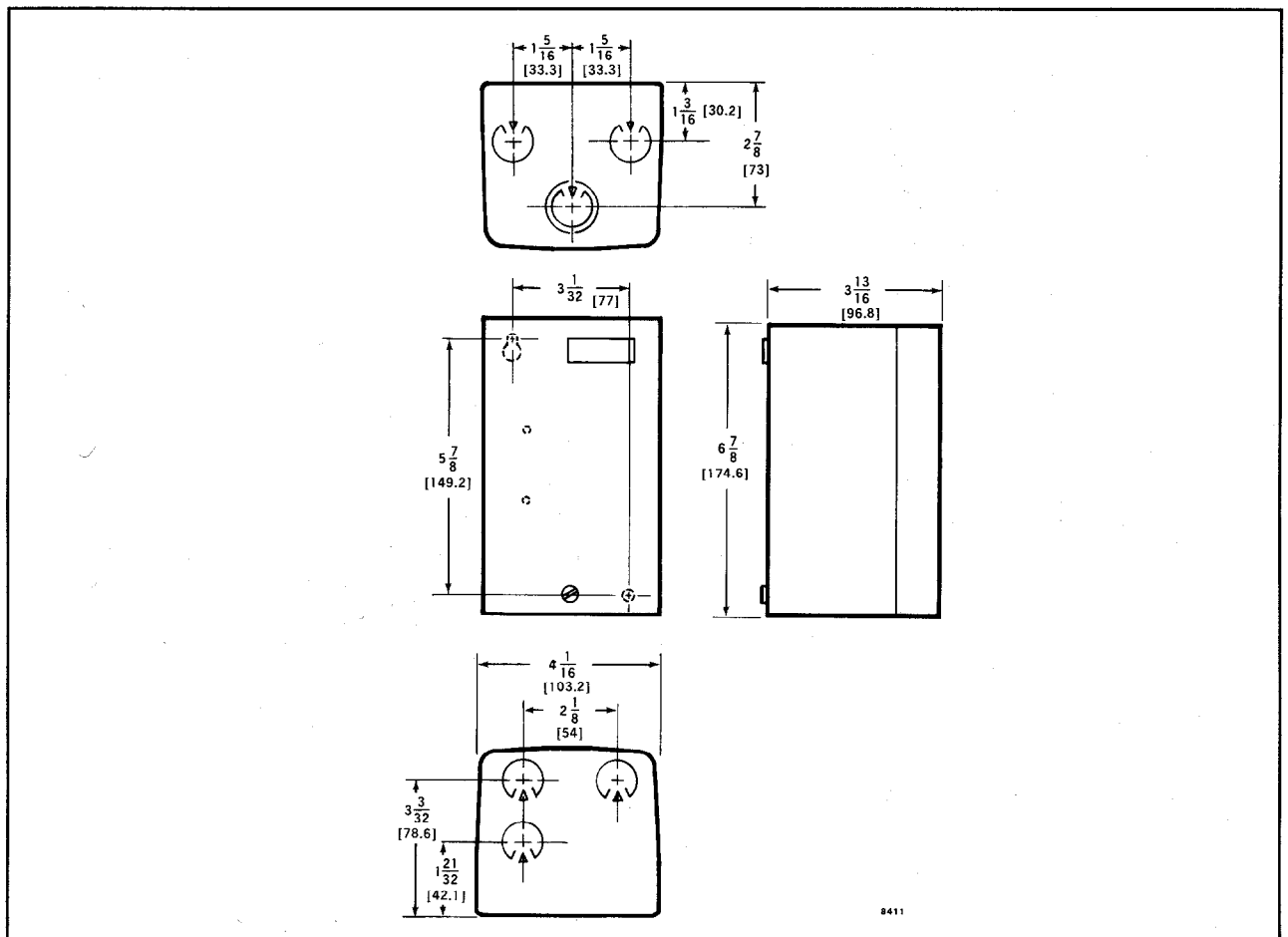

FIG. 4—DIMENSIONS OF ACCESSORY ENCLOSURE, PART NO. 138552B.

TABLE I CONTRACT RATINGS.

MODEL	MODEL RATING (AMP)	LINE VOLTS	MOTOR LOAD RATING AMP/POLE		RESISTIVE LOAD PER POLE	
			AFL	ALR	AMPERES	KILOWATTS
R4242A R8242A	25	240/277	25.0	125	30	7.2/8.3
		480	10.0	50	30	14.4
		600	8.0	40	30	18.0
R4242B R8242B	20	240/277	20.0	100	30	7.2/8.3
		480	10.0	50	30	14.4
		600	8.0	32	30	18.0
R4242C R8242C	23	240/277	23.0	100	30	7.2/8.3
		480	10.0	50	30	14.4
		600	8.0	40	30	18.0
R4243A R8243A	30	240/277	30.0 ^a	150	40	9.6/11.1
		480	15.0 ^b	75	40	19.2
		600	12.5	50	40	24.0
R4243B R8243B	30	240/277	30.0	125	40	9.6/11.1
		480	10.0	50	40	19.2
		600	8.0	32	40	24.0

^a Special models available with 35 AFL, 150 ALR rating at 240/277 Vac.

^b Special models available with 25 AFL, 125AFL rating at 240/277 Vac.

TABLE 2 R4242A,B,C; R4243A; R8242A,B,C; AND R8243A COIL RATINGS^a.

	24 V	120 V	208/240 V	277 V	
DC Resistive	9.25 ohms	235 ohms	950 ohms	1260 ohms	
Pickup Voltage (maximum) ^a	18 V	96 V	177 V	230 V	
Pickup Voltage (nominal)	16 ± 2 V	86 ± 10 V	157 ± 20 V	205 ± 25 V	
Max. Inrush VA at Rated Voltage	21.0 VA	21.0 VA	16.0 VA/21.0 VA	21.0 VA	
Nominal Inrush VA at Rated Voltage	19.2 VA	19.2 VA	14.6 VA/19.2 VA	19.2 VA	
Sealed VA (maximum)	10.5 VA	10.5 VA	8.0 VA/10.5 VA	10.5 VA	
Sealed VA (nominal)	9.5 VA	9.5 VA	7.3 VA/9.5 VA	9.5 VA	
Sealed Amperes (nominal)	0.390 A	0.078 A	0.035 A/0.039 A	0.034 A	
Sealed Wattage (nominal)	5.4 W	5.4 W	4.2 W/5.4 W	5.4 W	
Admittance	(open)	0.033	0.00134	0.00033	0.00025
	(sealed)	0.0165	0.00067	0.000165	0.000125

^a Voltages listed are for the contractor base mounted vertical. Performance for horizontal mounting is decreased by 12 percent.

TABLE 3 R4243B AND R8243B COIL RATINGS^a.

	24 V	120 V	208/240 V	277 V	
DC Resistive	8.45 ohms	220 ohms	875 ohms	1210 ohms	
Pickup Voltage (maximum) ^a	18 V	96 V	177 V	230 V	
Pickup Voltage (nominal)	16 ± 2 V	86 ± 10 V	157 ± 20 V	205 ± 25 V	
Max. Inrush VA at Rated Voltage	24.0 VA	24.0 VA	20.8 VA/24.0 VA	24.0 VA	
Nominal Inrush VA at Rated Voltage	22.5 VA	22.5 VA	19.5 VA/22.5 VA	22.5 VA	
Sealed VA (maximum)	12.0 VA	12.0 VA	10.4 VA/12.0 VA	12.0 VA	
Sealed VA (nominal)	11.0 VA	11.0 VA	9.5 VA/11.0 VA	11.0 VA	
Sealed Amperes (nominal)	0.455 A	0.100 A	0.039 A/0.045 A	0.038 A	
Sealed Wattage (nominal)	5.9 W	5.9 W	4.4 W/5.9 W	5.9 W	
Admittance	(open)	0.039	0.0015	0.00039	0.00028
	(sealed)	0.019	0.00075	0.00019	0.00028

^a Voltages listed are for the contractor base mounted vertical. Performance for horizontal mounting is decreased by 12 percent

INSTALLATION

WHEN INSTALLING THIS PRODUCT . . .

1. Read these instructions carefully. Failure to follow them could damage the product or cause a hazardous condition.
2. Check the ratings given in the instructions and on the product to make sure the product is suitable for your application.
3. Installer must be a trained, experienced service technician.
4. After installation is complete, check out product operation as provided in these instructions.

CAUTION

Disconnect power supply to prevent electrical shock or equipment damage.

LOCATION

Mount the contactor on a flat, solid surface as close as possible to the equipment being controlled. The contactor mounts in any position (see Table 2 footnote) with 2 screws through the base or with a shear formed panel tab and a single screw as shown in Fig. 5.

WIRING

All wiring must comply with local codes and ordinances. Attach line wires to the contactor using the terminal clamp screws (No. 10 binding screw terminals on 20 ampere contactor); load wires using the No. 10 binding screws. Pressure lugs are recommended for field wiring with wire larger than No. 8.

The contactor has terminal numbers stamped on the terminal block for easy identification when wiring. Refer to wiring instructions provided by the equipment manufacturer, or see Figs. 6 and 7 for typical system connections. Do not exceed the contact and coil ratings when wiring into system.

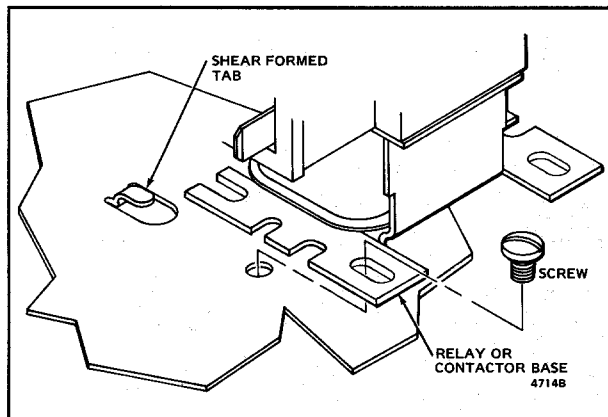

FIG. 5—TYPICAL CONTACTOR MOUNTING IN SHEAR FORMED PANEL WITH ONE SCREW.

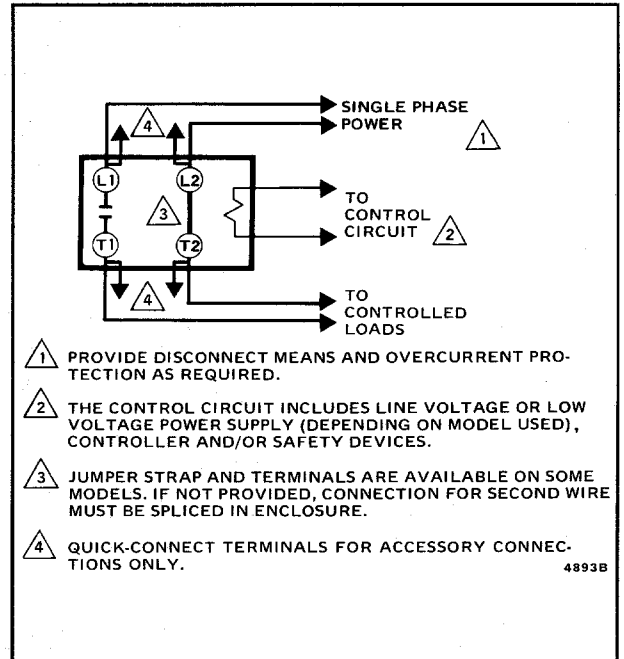

FIG. 6—TYPICAL HOOKUP FOR R4242A,C; R4243A; R8242A,C OR R8243A.

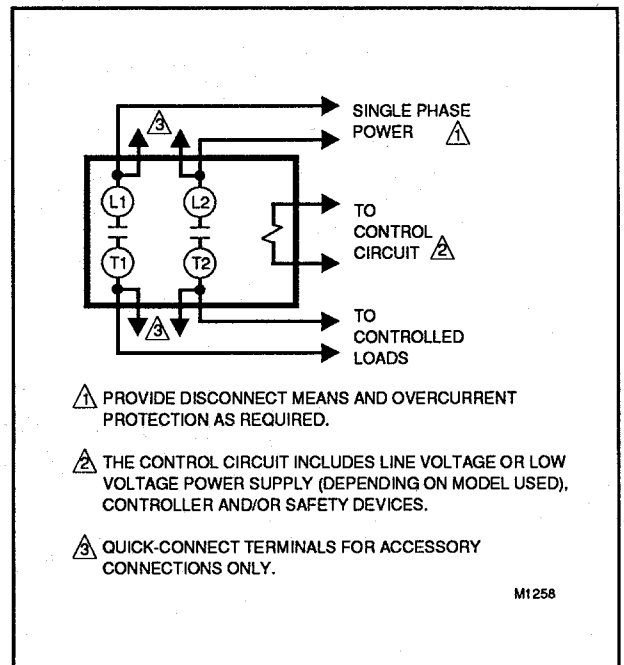

FIG. 7—TYPICAL HOOKUP FOR R4242B, R8242B, R4243B OR R8243B.

CHECKOUT

Always conduct a thorough checkout when installation is complete. Restore the power supply, and operate the contactor and controlled equipment to make sure the contactor pulls in when the coil is energized and controlled equipment operates as intended.

Free Manuals Download Website

<http://myh66.com>

<http://usermanuals.us>

<http://www.somanuals.com>

<http://www.4manuals.cc>

<http://www.manual-lib.com>

<http://www.404manual.com>

<http://www.luxmanual.com>

<http://aubethermostatmanual.com>

Golf course search by state

<http://golfingnear.com>

Email search by domain

<http://emailbydomain.com>

Auto manuals search

<http://auto.somanuals.com>

TV manuals search

<http://tv.somanuals.com>