

APPLICATION

The VR8200H Continuous Pilot Combination Gas Control is used in gas-fired appliances from 20 to 200 cfh natural gas capacity. It includes safety shutoff a manual valve, two automatic operators, a pressure regulator, a pilot filter, 1/4 in. quick-connect convenience terminals, and an ECO connector with two 1/4 in. quick-connect convenience terminals.

The VR8200H operates at 24V/60 Hz and has an ambient temperature range of 0° F to 175° F [-18° C to 78° C]. The thermostat heat anticipator setting is 0.5A.

Angle and straight adapters are available for 3/8, 1/2, and 3/4 in. pipe. Refer to Table 1 for adapter part numbers. Flange kits include one flange with attached O-ring, four mounting screws, a 9/64 in. hex wrench, and instruction sheet.

The VR8200H is factory-set for natural gas. Do not attempt to use VR8200H on LP gas. To convert VR8200H from natural gas to LP gas, follow instructions in LP gas conversion kit.

TABLE 1—FLANGE PART NUMBERS.

INLET/ OUTLET PIPE SIZE	FLANGE TYPE	PART NO. LESS HEX WRENCH	PART NO. WITH HEX WRENCH
3/8 in. NPT	Straight	393690-1	393690-11
	Elbow*	393690-2	393690-12
1/2 in. NPT	Straight	393690-6	393690-16
	Elbow*	393690-3	393690-13
3/4 in. NPT	Straight	393690-4	393690-14
	Elbow*	393690-5	393690-15

* Elbow (angle) flanges cannot provide right hand inlet when the ECO connector is used.

NOTE: Flange Kits include one flange with attached O-ring and four mounting screws.

AMERICAN GAS ASSOCIATION DESIGN CERTIFICATE:
P-70-42A.

CANADIAN GAS ASSOCIATION DESIGN CERTIFICATE:
1029-CC-6395 series.

AUSTRALIAN GAS ASSOCIATION CERTIFICATE: 4214.

INSTALLATION

WHEN INSTALLING THIS PRODUCT...

1. Read these instructions carefully. Failure to follow them could damage the product or cause a hazardous condition.

2. Check the ratings given in the instructions and on the product to make sure the product is suitable for your application.

3. Installer must be a trained, experienced service technician.

4. After installation is complete, check out product operation as provided in these instructions.

WARNING

**FIRE OR EXPLOSION HAZARD
CAN CAUSE PROPERTY DAMAGE, SEVERE
INJURY OR DEATH.**

Follow these warnings exactly.

1. Disconnect power supply before wiring to prevent electrical shock or equipment damage.
2. To avoid dangerous accumulation of fuel gas, turn off gas supply at the appliance service valve before starting installation, and perform Gas Leak Test after completion of installation.
3. Do not attempt to use a control set for natural (manufactured) gas on LP gas, or a control set for LP on natural gas.
4. Do not bend pilot tubing at gas control or pilot burner after compression nut has been tightened, or gas leakage at the connection may result.
5. Always install sediment trap in gas supply line to prevent contamination of gas control.
6. Do not force the gas control knob. Use only your hand to push down the reset button or turn the gas control knob. Never use any tools. If the knob or reset button will not operate by hand, the control should be replaced by a qualified service technician. Force or attempted repair may result in fire or explosion.

CAUTION

Never apply a jumper across or short the valve coil terminals. This may burn out the heat anticipator in the thermostat.

IMPORTANT

These gas controls are shipped with protective seals over inlet and outlet tappings. Do not remove seals until ready to connect piping.

Follow the appliance manufacturer's instructions if available; otherwise, use the instructions provided below.

INSTALL ADAPTERS TO CONTROL

If adapters are installed on the gas control, mount them as follows:

Flanges:

1. Choose the appropriate flange for your application.

NOTE: A right angle inlet flange cannot be used with ECO connected.

2. Remove seal over control inlet or outlet.

3. Check to ensure that the O-ring is fitted in the groove of flange. If the O-ring is not attached or is missing, do not use the flange.

4. With O-ring facing valve, line up the screw holes on the control with the holes in the flange. Insert and tighten the screws provided with the flange. See Fig. 1. Tighten the screws to 25 in. pounds of torque to provide a gas-tight seal.

Bushings:

1. Remove seal over control inlet or outlet.
2. Apply moderate amount of good quality pipe compound to bushing, leaving two end threads bare. On LP installation, use compound resistant to LP gas. Do NOT use Teflon tape.
3. Insert bushing in control and thread pipe carefully into bushing until tight.

Complete instructions below for piping, installing control, connecting pilot tubing, thermocouple and wiring. Make certain the leak test you perform on the control after completing the installation includes leak testing the adapters and screws. If you use a wrench on the valve after flanges are installed, use the wrench only on the flange, not the control.

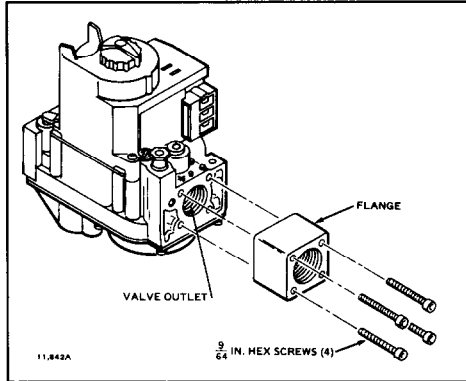

Fig. 1—Fasten flange to valve firmly, but do not overtighten screws.

LOCATION

Do not locate the combination gas control where it may be affected by steam cleaning, high humidity, or dripping water, corrosive chemicals, dust or grease accumulation, or excessive heat. To ensure proper operation, follow these guidelines.

- Locate in a well ventilated area.
- Mount high enough above the cabinet bottom to avoid exposure to flooding or splashing water.
- Ensure the ambient temperature does not exceed the ambient temperature ratings for each component.
- Cover gas control if appliance is cleaned with water, steam, or chemicals or to avoid dust and grease accumulation.
- Avoid locating where exposure to corrosive chemical fumes or dripping water are likely.

Mount the combination gas control in the appliance vestibule on the gas manifold. If this is a replacement application, mount the new control in the same location as the old control.

Install Piping to Control

All piping must comply with local codes and ordinances or with the National Fuel Gas Code (ANSI Z223.1 NFPA No. 54), whichever applies. Tubing installation must comply with approved standards and practices.

1. Use new, properly reamed pipe free from chips. If tubing is used, make sure the ends are square, deburred and clean. All tubing bends must be smooth and without deformation.
2. Run pipe or tubing to the control. If tubing is used, obtain a tube-to-pipe coupling to connect the tubing to the control.
3. Install sediment trap in the supply line to the gas control. See Fig. 2.

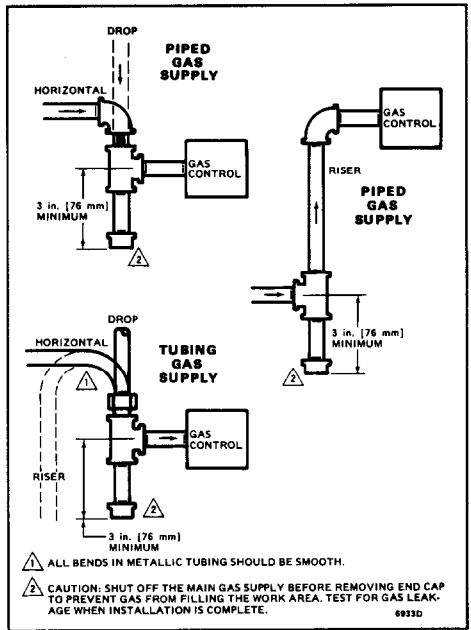

Fig. 2—Sediment trap installation.

Install Control

1. This control can be mounted 0-90 degrees, in any direction, from the upright position of the gas control knob, including vertically.
2. Mount the control so gas flow is in the direction of the arrow on the bottom of the control.
3. Thread pipe the amount shown in Table 2 for insertion into control. DO NOT THREAD PIPE TOO FAR. Valve distortion or malfunction may result if the pipe is inserted too deeply.

TABLE 2—NPT PIPE THREAD LENGTH (in.).

PIPE SIZE	THREAD PIPE THIS AMOUNT	MAXIMUM DEPTH PIPE CAN BE INSERTED INTO CONTROL
3/8	9/16	3/8
1/2	3/4	1/2
3/4	13/16	3/4

4. Apply a moderate amount of good quality pipe compound (DO NOT use Teflon tape) to pipe only, leaving two end threads bare. On LP installations, use compound resistant to LP gas. See Fig. 3.

5. Remove seals over control inlet and outlet, if necessary.

6. Connect pipe to control inlet and outlet. Use wrench on the square ends of the control. If a flange is used, place wrench on flange rather than control. Refer to Figs. 4 and 5.

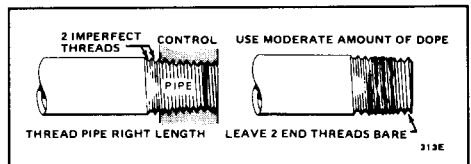

Fig. 3—Use moderate amount of pipe compound.

Connect Pilot Gas Tubing

1. Cut tubing to desired length and bend as necessary for routing to pilot burner. Do not make sharp bends or deform the tubing. Do not bend tubing at control after compression nut has been tightened, as this may result in gas leakage at the connection.

2. Square off and remove burrs from end of tubing.

3. Unscrew brass compression fitting from the pilot outlet (Fig. 4). Slip the fitting over the tubing and slide out of the way.

NOTE: When replacing a control, cut off old compression fitting and replace with the compression fitting provided on the combination gas control. Never use the old compression fitting as it may not provide a gas-tight seal. See Fig. 6.

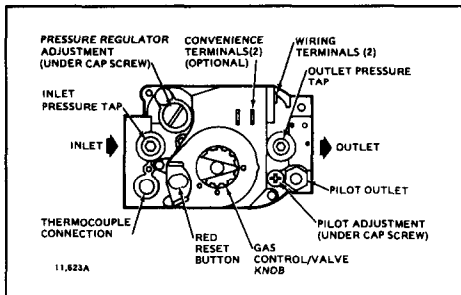

Fig. 4—Top view of gas control.

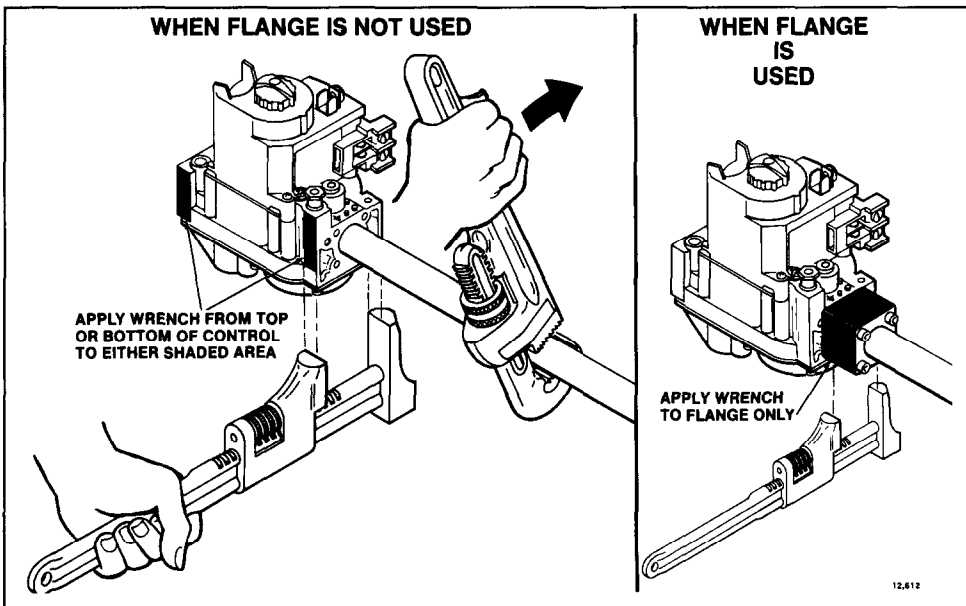

Fig. 5—Proper use of wrench on gas control with and without flanges.

4. Push tubing into the pilot gas tapping on the outlet end of the control until it bottoms. While holding tubing all the way in, slide fitting into place and engage threads—turn until finger tight. Then tighten one more turn with wrench. Do not overtighten.

5. Connect other end of tubing to pilot burner according to pilot burner manufacturer's instructions.

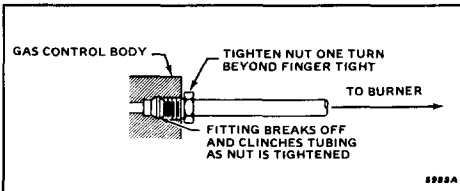

Fig. 6—Always use new compression fitting.

Connect Thermocouple

If a supplementary limit or energy cutoff will be used, insert the ECO connector (order Part No. 394332) as shown in Fig. 7 then connect thermocouple lead. If not, insert thermocouple lead directly. This is an electrical connection

and must be clean and dry. Never use pipe compound. Tighten only 1/4 turn beyond finger tight to give good electrical continuity. DO NOT OVERTIGHTEN.

WIRING

Follow the wiring instructions furnished by the appliance manufacturer, if available, or use the general instructions provided below.

All wiring must comply with applicable electrical codes and ordinances.

Disconnect power supply before making wiring connections to prevent electrical shock or equipment damage.

1. Check the power supply rating on the valve and make sure it matches the available supply. Install transformer, thermostat and other controls as required.

2. Connect control circuit to gas control terminals. See Figs. 4 and 8.

Connect Supplementary Limit or ECO (If used)

The leadwires from the high limit or ECO must be equipped with insulated 1/4 in. female quick-connect terminals. Leadwire lengths must not exceed the lengths shown in Tables 5 and 6. Connect the high-limit or ECO leadwires to the two terminals on the ECO connector.

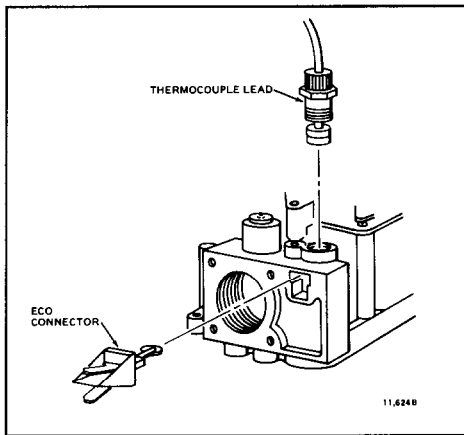

Fig. 7—Installing thermocouple and optional ECO adapter to the power unit.

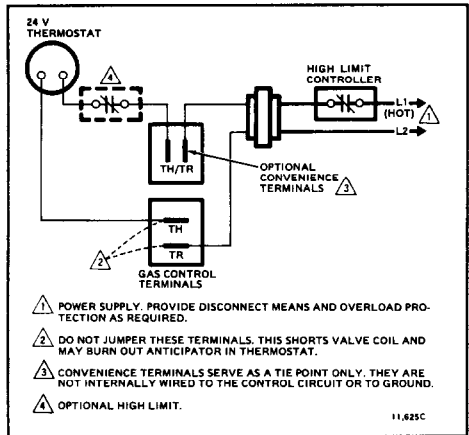

Fig. 8—Wiring connections for 24 volt control.

TABLE 3—MAXIMUM LENGTH OF SUPPLEMENTARY LIMIT LEADWIRES WHEN USING Q340A THERMOCOUPLE.

THERMOCOUPLE LENGTH		MAXIMUM LEADWIRE LENGTH X 2 (wires)					
		AWG NO. 14		AWG NO. 16		AWG NO. 18	
in.	m	in.	m	in.	m	in.	m
18	0.5	35	0.9	22	0.6	13	0.3
24	0.6	29	0.7	18	0.5	11	0.3
30	0.8	23	0.6	15	0.4	9	0.2
36	0.9	17	0.4	11	0.3	6	0.2
48	1.2	DO NOT USE					
72	1.8						

TABLE 4—MAXIMUM LENGTH OF SUPPLEMENTARY LIMIT LEADWIRES WHEN USING Q309A THERMOCOUPLE.

THERMOCOUPLE LENGTH		MAXIMUM LEADWIRE LENGTH X 2 (wires)					
		AWG NO. 14		AWG NO. 16		AWG NO. 18	
in.	m	in.	m	in.	m	in.	m
12	0.3	47	1.2	30	0.8	18	0.5
18	0.5	41	1.0	26	0.7	16	0.4
24	0.6	35	0.9	22	0.6	14	0.4
30	0.8	29	0.8	18	0.5	11	0.3
36	0.9	23	0.6	15	0.4	9	0.2
40	1.0	19	0.5	12	0.3	7	0.2
48	1.2	11	0.3	7	0.2	DO NOT USE	
60	1.5						

STARTUP AND CHECKOUT

WARNING

FIRE OR EXPLOSION HAZARD CAN CAUSE PROPERTY DAMAGE, SEVERE INJURY, OR DEATH

- Do not force the gas control knob. Only use your hand to push down and turn gas control knob. Never use any tools.
- If the gas control knob will not operate by hand, a new control should be installed by a qualified service technician.

GAS CONTROL KNOB SETTINGS

Gas control knob settings are as follows:

OFF prevents pilot and main gas flow through the control.

PILOT permits gas to flow to the pilot burner as long as red knob is held down or thermocouple current is above the power unit dropout value.

ON permits gas to flow into the control body. Pilot gas is controlled as in the PILOT position. Main burner gas flow is controlled by the thermostat and automatic valve operator(s).

NOTE: Valves are shipped with the gas control knob in the ON position.

PERFORM GAS LEAK TEST

WARNING





**FIRE OR EXPLOSION HAZARD
CAN CAUSE PROPERTY DAMAGE, SEVERE IN-
JURY OR DEATH**

**Check for gas leaks with soap and water solution
any time work is done on a gas system.**

GAS LEAK TEST:

1. Paint pipe connections upstream of gas control with rich soap and water solution. Bubbles indicate gas leak.
2. If leak is detected, tighten pipe connections.
3. Stand clear of main burner while lighting to prevent injury caused from hidden leaks which could cause flashback in the appliance vestibule. Light main burner.
4. With main burner in operation, paint pipe joints (including adapters) and control inlet and outlet with rich soap and water solution.
5. If another leak is detected, tighten adapter screws, joints, and pipe connections.
6. Replace part if leak can't be stopped.

LIGHT PILOT



1. Rotate the gas control knob clockwise  to OFF. Wait five minutes to allow any unburned gas to dissipate. Sniff around the appliance near the floor. Don't relight if you smell gas.
2. Rotate the gas control knob counterclockwise  to PILOT. Push down and hold the red reset button while you light pilot burner according to appliance manufacturer's instructions.
3. After about one minute, release reset button. Pilot should remain lit. If it goes out, turn gas control knob clockwise  to OFF. To relight, repeat steps 1-3.
4. After pilot remains lit when red reset button is released, turn gas control knob counterclockwise  to ON.

TURN ON MAIN BURNER

Follow instructions provided by appliance manufacturer or turn thermostat up to call for heat.

ADJUST PILOT FLAME

The pilot flame should envelope 3/8 to 1/2 in. [10 to 13 mm] of the tip of the thermocouple. See Fig. 9.

1. Remove pilot adjustment cover screw. See Fig. 4.
2. Turn inner adjustment screw clockwise  to decrease or counterclockwise  to increase pilot flame.
3. Replace cover screw after adjustment to prevent gas leakage.

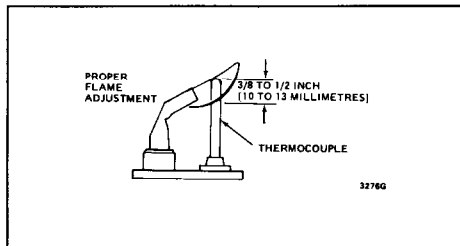



Fig. 9—Proper flame adjustment.

CHECK AND ADJUST GAS INPUT AND BURNER IGNITION

CAUTION

1. Do not exceed input pressure rating stamped on appliance nameplate, or manufacturer's recommended burner orifice pressure for size orifice(s) used. Make certain primary air supply to main burner is properly adjusted for complete combustion. Follow appliance manufacturer instructions.
2. IF CHECKING GAS INPUT BY CLOCKING GAS METER:
 - Ensure that the only gas flow through the meter is that of the appliance being tested.
 - Ensure other appliances are turned off and their pilot flames are extinguished (or deduct their gas consumption from the meter reading).
 - Convert flow rate to Btuh as described in the Gas Controls Handbook (form number 70-2602) and compare to Btuh input rating on appliance nameplate.
3. IF CHECKING GAS INPUT WITH MANOMETER:
 - Ensure gas control knob is in PILOT position before removing outlet pressure tap plug to connect manometer (pressure gauge).
 - Turn gas control knob back to PILOT when removing manometer and replacing plug.
 - Shut off gas supply at the appliance service valve or, for LP gas, at the gas tank before removing outlet pressure tap plug and before disconnecting manometer and replacing outlet pressure tap plug.
 - Perform Gas Leak Test at inlet pressure tap plug.

1. Ensure the input pressure rating listed on the appliance nameplate matches the gas control outlet pressure.
2. With main burner operating, check gas control flow rate using the meter clocking method or gas control outlet pressure rating using a manometer connected to the gas control outlet pressure tap. Refer to Fig. 4.
3. If necessary, adjust gas control outlet pressure to match appliance input pressure rating. Outlet pressure for natural gas is normally set at 3.5 in. wc [0.9 kPa] and adjustable from 3 to 5 in. wc [0.74 to 1.2 kPa]. Outlet pressure for LP gas is normally set at 10 in. wc [2.5 kPa] and adjustable from 8 to 12 in. wc [2 to 3 kPa].
 - a. Remove pressure regulator adjustment cap and screw.
 - b. Using screwdriver, turn inner adjustment screw clockwise  to increase or counterclockwise  to decrease gas pressure to burner.
 - c. Always replace cap screw and tighten firmly to ensure proper operation.
4. If desired outlet pressure or flow rate cannot be achieved by adjusting the control, check the control inlet pressure using a manometer at the inlet pressure tap.
 - If inlet pressure is in normal range, replace the control.
 - If inlet pressure is not in normal range, take steps to provide proper gas pressure to the control.

CHECK SAFETY SHUTDOWN PERFORMANCE

WARNING

**FIRE OR EXPLOSION HAZARD
CAN CAUSE PROPERTY DAMAGE, SEVERE IN-
JURY OR DEATH**
**Perform the safety shutdown test any time work is
done on a gas system.**

1. Place gas control knob in PILOT position. Main burner should go off and pilot should remain lit.

2. Extinguish pilot flame. Pilot gas flow should stop within 2-1/2 minutes. Safety shutoff of pilot gas proves complete shutdown since safety shutoff valve blocks flow of gas to main burner and pilot.

3. Relight pilot burner and operate system through one complete cycle to make sure all controls operate properly.

SERVICE

WARNING

**FIRE OR EXPLOSION HAZARD
CAN CAUSE PROPERTY DAMAGE, SEVERE
INJURY OR DEATH**

Do not take this control apart; it contains no replaceable components. Attempted disassembly or repair may damage the control.

CAUTION

Do not apply a jumper across (or short) the valve coil terminals, even temporarily. Doing so may burn out the heat anticipator in the thermostat.

IF PILOT WILL NOT LIGHT

1. Make sure the main gas supply valve is open and the pilot gas supply line is purged of air.
2. Attempt to light pilot following procedure in "Light Pilot," page 5.
3. If pilot will not light, check for:
 - a. closed pilot gas adjustment screw.
 - b. clogged pilot burner tubing or orifice.
 - c. gas leak at compression fitting.

IF PILOT GOES OUT WHEN RESET BUTTON IS RELEASED

1. Make sure the reset button is held in at least one minute to allow the thermocouple time to heat.
2. Check pilot flame adjustment, see page 5.
3. Check the connection to the power unit. This is an electrical connection and must be clean and secure.
4. If pilot still goes out, use a millivoltmeter to measure the exact open and closed circuit output voltages of the thermocouple. Compare to acceptable range charts in the thermocouple specifications. Replace the thermocouple if voltages are outside the acceptable range; otherwise, replace the gas control.

IF MAIN BURNER WILL NOT COME ON WITH CALL FOR HEAT

1. Confirm that gas control knob is in the ON position.
2. Adjust thermostat several degrees above room temperature.
3. Using ac voltmeter, measure voltage across thermostat terminals at gas control.
4. If no voltage is present, check control circuit for proper operation.
5. If proper control system voltage is present, replace gas control.

WARNING

**FIRE OR EXPLOSION HAZARD
CAN CAUSE PROPERTY DAMAGE, SEVERE
INJURY, OR DEATH**

Follow these warnings exactly:

1. Pilot must be lit manually. Follow these instructions exactly.
2. Before lighting, smell around the appliance for gas. Be sure to smell next to floor because LP gas is heavier than air.
3. IF YOU SMELL GAS:
 - Turn off gas supply at appliance service valve. On LP gas systems, turn off gas supply at the tank.
 - Do not light any appliances in the house.
 - Do not touch electrical switches or use the phone.
 - Leave the building and use a neighbor's phone to call your gas supplier.
 - If you can not reach your gas supplier, call the fire department.
4. Do not force the gas control knob. Use only your hand to push down or turn the gas control knob. Never use any tools. If the gas control knob will not operate by hand, the gas control should be replaced by a qualified service technician. Force or attempted repair may result in fire or explosion.
5. The gas control must be replaced in case of any physical damage, tampering, bent terminals, missing or broken parts, stripped threads, or evidence of exposure to heat.

LIGHTING THE PILOT BURNER STOP" READ THE WARNINGS ABOVE.

This appliance has a pilot burner which must be lit manually. If the pilot flame has gone out, follow these instructions exactly.

1. Set the thermostat to its lowest setting.
2. Disconnect all electric power to the appliance.
3. Remove gas control access panel.
4. Push in gas control knob slightly and turn clockwise  to OFF.

NOTE: Gas control knob can not be turned from PILOT to OFF unless it is pushed in slightly. Do not force gas control knob.

5. Wait five minutes to clear out any gas. If you then smell gas, STOP! Follow "Step 3" in the warnings above. If you do not smell gas, continue with next step.
6. Remove the pilot burner access panel located below and behind the gas control.
7. Find the pilot burner by following the metal tube from the gas control. The pilot is between the two burner tubes behind the pilot burner access panel.
8. Turn gas control knob on gas control counterclockwise  to PILOT.
9. Push in gas control knob all the way and hold in. Immediately light the pilot flame with a match and continue holding the gas control knob in for one minute after the pilot flame is lit.
10. Release gas control knob and it will pop back up. Pilot flame should remain lit. If pilot goes out, repeat steps 1 through 10.

- If gas control knob does not pop up when released, stop and immediately call your service technician or gas supplier.
- If the pilot flame will not stay lit after several tries, turn the gas control knob to OFF and call your service technician or gas supplier.

11. Turn gas control knob counterclockwise  to ON.
12. Replace pilot burner access panel.
13. Replace gas control access panel.

14. Reconnect all electric power to the appliance.
15. Set the thermostat to desired setting.

TURNING OFF THE APPLIANCE

VACATION SHUTDOWN—Set thermostat to desired room temperature while you are away.

COMPLETE SHUTDOWN—Push in gas control knob slightly and turn clockwise  to OFF. Do not force. Appliance will completely shut off. Follow lighting procedures above to resume normal operation.

Free Manuals Download Website

<http://myh66.com>

<http://usermanuals.us>

<http://www.somanuals.com>

<http://www.4manuals.cc>

<http://www.manual-lib.com>

<http://www.404manual.com>

<http://www.luxmanual.com>

<http://aubethermostatmanual.com>

Golf course search by state

<http://golfingnear.com>

Email search by domain

<http://emailbydomain.com>

Auto manuals search

<http://auto.somanuals.com>

TV manuals search

<http://tv.somanuals.com>