

Instruction Manual

HONEYWELL TOP FILL COOL MOISTURE HUMIDIFIER

MODEL HEV680 SERIES

REPLACEMENT FILTER: HONEYWELL HC-14 SERIES FILTER E

GETTING TO KNOW YOUR COOL MOISTURE EVAPORATIVE HUMIDIFIER

Invisible moisture

- Evaporative humidification means you will **NOT** see the moisture output.
- With evaporative humidification, a fan pulls dry air from the room through the saturated wicking filter. Moisture from the wicking filter evaporates and is pushed into the room with the help of the fan.
- Evaporative humidification adjusts moisture output to the amount of moisture the air can hold. The drier (less humid) the air in the room, the more moisture the humidifier will add to the air. An evaporative humidifier cannot add more moisture to the room than the air can hold. The amount of moisture the air can hold depends on many factors including relative humidity level, temperature and size of room.



Filter

- A wicking filter is required for this unit to operate (one included)
- The wicking filter will help to capture minerals from your water and will help to prevent white dust (calcium deposits from hard water)
- If you have hard water, you will need to replace your filter more frequently
- See “Caring for your Filter” section for tips on prolonging the life of your wicking filter



Humidity Level

- The ideal indoor humidity level is 40-60%
- Use a Honeywell humidity monitor (HHM10 or H10C) to check your indoor humidity level (not included)

Visit www.honeywellcomfort.com (in US) or www.honeywellcomfort.ca (in Canada)
Call **800-477-0457** for questions and information about this humidifier



SAFETY INSTRUCTIONS

READ AND SAVE THESE SAFETY INSTRUCTIONS BEFORE USING THIS HUMIDIFIER

When using electrical appliances, basic precautions should always be followed to reduce the risk of fire, electrical shock and injury to persons, including the following:

1. The humidifier should always be placed on a firm, flat, waterproof surface at least four feet (1.2 m) away from bedside, twelve inches (30 cm) from the wall, and out of reach of patients, children and pets.
2. Be sure the humidifier is in a stable position and the power cord is away from heated surfaces and out of the way to prevent the humidifier from being tipped over.
3. Before using the humidifier extend the cord and inspect for any signs of damage. **Do not** use the unit if the cord has been damaged.
4. The humidifier has a polarized plug (one blade is wider than the other) as a safety feature. This plug will fit into a polarized outlet only one way. If the plug does not fit fully into the outlet, reverse the plug. If it still does not fit, contact a qualified electrician. **Do not** attempt to defeat this safety feature.
5. **⚠ CAUTION:** To avoid fire or shock hazard, plug the humidifier directly into a 120V AC electrical outlet. To avoid risk of fire, shock or personal injury **do not** use an extension cord.
6. Shut off and unplug humidifier before moving. The humidifier should always be unplugged and emptied when not in operation or while being cleaned. **Do not** move or tilt humidifier while it is in operation. Plug and unplug humidifier with dry hands. Never pull by cord.
7. When moving or lifting the full Water Tank, use two hands; one hand on the Tank Handle and the other on the bottom of the Tank.
8. **Do not** add any medications, inhalants, scented products or essential oils into Base, Water Reservoir or Water Tank.
9. **Do not** cover or insert objects into any openings on the humidifier.
10. **Do not** block intake or output vents.
11. **Do not** operate the humidifier without water. Turn off and unplug unit when Tank is empty.
12. Humidifier requires regular cleaning. Refer to, and follow, cleaning instructions.
13. **Do not** operate outdoors; this appliance is intended for indoor use.
14. **Do not** attempt to repair or adjust any electrical or mechanical functions on this humidifier. Doing so will void your warranty.
15. For residential use only.

SAVE THESE INSTRUCTIONS

HEV680 Series HUMIDIFIER COMPONENTS

How Evaporative Humidification Works:

A Wicking Filter inside the humidifier absorbs water from the Reservoir. A fan pulls dry air from the room into the humidifier where it passes through the saturated Wicking Filter. The Filter captures minerals and other impurities from the water, before the moisture is evaporated back into the dry room with the help of the fan. The amount of moisture output depends on many factors, including the current room humidity and temperature. As the humidity level in the room increases, the moisture output decreases, which prevents over humidification.

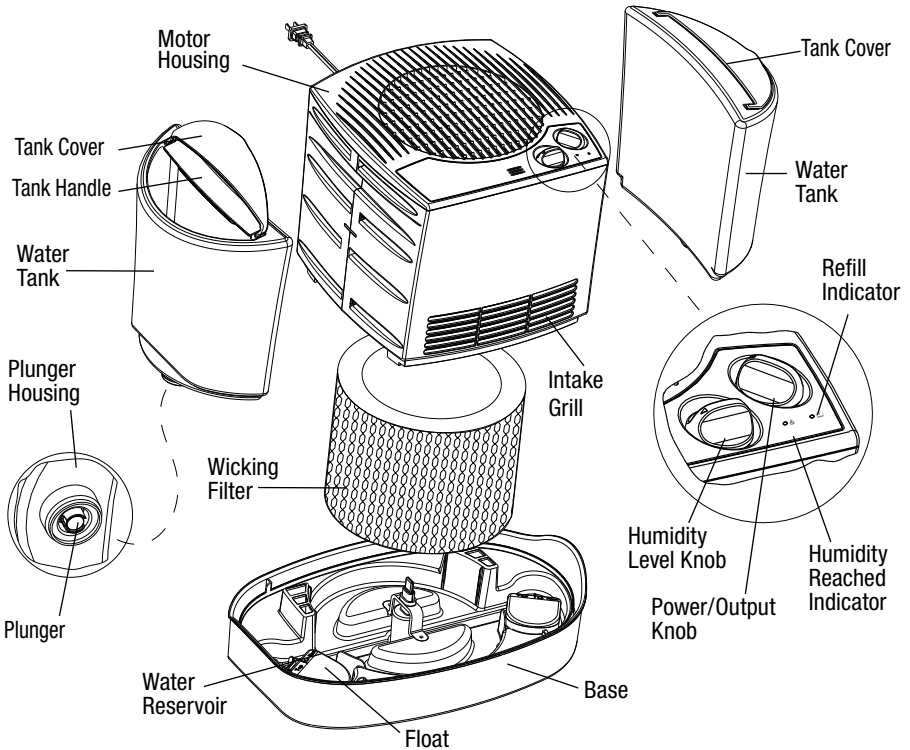

SETTING UP YOUR HUMIDIFIER

1. Remove packaging material. Keep this Instruction Manual for future reference.
2. Remove twist tie and extend power cord.
3. Place the humidifier

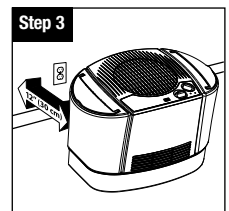
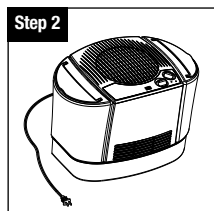

on a firm, level, water resistant surface at least 12" (30 cm) from any walls. **Do not** block Intake Grill on base of unit. **Do not** place on surfaces that can be damaged by water.

PREPARING THE WICKING FILTER

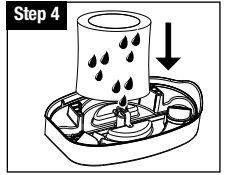
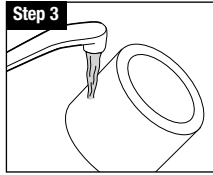
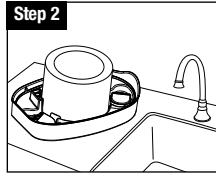
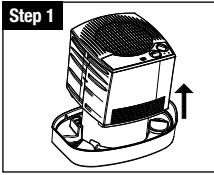

1. Remove Water Tanks and lay aside. Grip housing and lift up to expose Wicking Filter.
2. Carry Wicking Filter and Base to sink or tub.
3. Remove Filter from Base and run under cool water until saturated.
4. Carefully place wet Filter back in base; do not squeeze out excess water.

FILLING/REFILLING WATER TANKS

The Tanks can be filled in two ways.

To fill without removing Water Tanks:

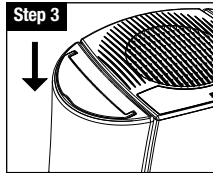
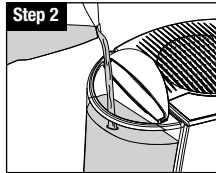
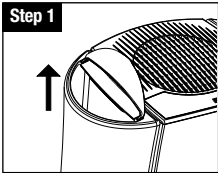

1. Flip Tank Cover open.
2. Pour cool tap water into Water Tank through the Tank Cover opening. Do not use warm or hot water.
3. Close Tank Cover to keep objects and debris out of water.
Repeat for second Water Tank.

To fill at the sink or tub by removing Water Tanks:

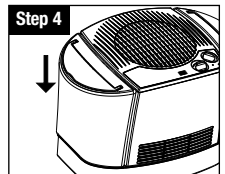
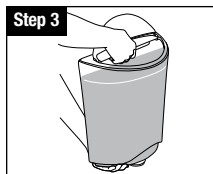
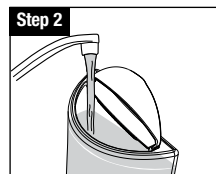
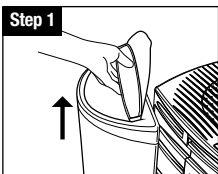

1. Flip Tank Cover open. Grasp Tank Handle and lift Water Tank to remove from Base. Carry Tank to sink or tub. **NOTE:** Do not use the Tank Cover to carry Water Tank.
2. Fill Tank through the Tank Cover opening. When filling, allow enough space at the top to minimize splashing when carrying. Use cool tap water; Do not use warm or hot water.

NOTE: Do not attempt to unscrew Plunger Housing from underside of Tank. This is not meant to be removed.

FILLING/REFILLING WATER TANKS

(Continued)

3. Carry Water Tank back to humidifier using two hands; one hand on Tank Handle at the top of the Tank and other hand supporting the bottom of the Tank. Take care not to push the Plunger on the bottom of the Water Tank or leaking may occur.
4. Place the Water Tank on the humidifier Base. Close Tank Cover. You may hear the water draining into the Reservoir.
Repeat with second Water Tank.

USING YOUR HUMIDIFIER

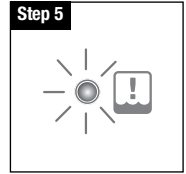
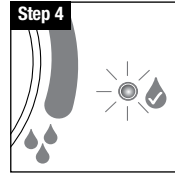
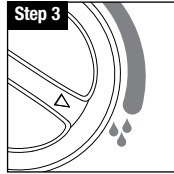
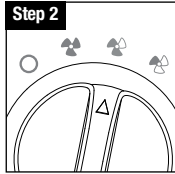
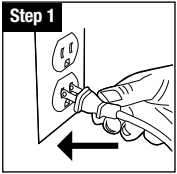

Power Control

1. With Power Knob in the OFF position, plug humidifier into a polarized 120V outlet.
CAUTION: To avoid electric shock, do not plug humidifier into outlet with wet hands.
2. Turn the Power/Output knob to desired fan setting.
High (☪): Fast humidifying
Medium (☪☪): Everyday moisture control
Low (☪☪☪): Quiet setting

Humidity Control

3. Turn the Humidity Level Knob to the highest setting and run for at least an hour or until a comfortable humidity level is reached.
4. Then turn the Humidity Level Knob to the left until the green Humidity Reached Indicator light turns on (☪☪☪) and the humidifier turns off. This is your desired humidity level. Now that your desired humidity level is set, the humidifier will automatically turn back on when your room drops below this comfort setting and will automatically turn off again when the comfort setting is reached.
NOTE: For continuous operation, set to high (☪☪☪).

Water Tanks

5. When both Water Tanks are empty, the humidifier will automatically shut off and the orange Refill Indicator (☪☪☪☪) will light up. Turn off the humidifier and refill the Tanks. See Filling/Refilling Water Tanks on previous page.
NOTE: If the humidifier will not be used for more than a few days, empty the water from the Water Tanks and Water Reservoir and dry out the Filter to prevent growth of bacteria or mold.

USING YOUR HUMIDIFIER

(Continued)

NOTE: While the humidifier is operating, you will hear the fan running but will not see the moisture output. This is normal for an evaporative humidifier.

To check the humidity level in the room, use a humidity monitor like the Honeywell HHM10 or H10C, available at retailers or online at www.honeywellcomfort.com



CARING FOR YOUR FILTER

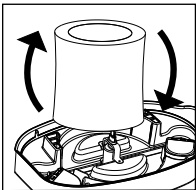

To prolong the life of your Wicking Filter, turn it over each time you fill the Water Tank. This will keep the top of the Filter from drying out and will help the Filter to age more evenly.

If you notice the Filter getting hard, you may soak it in cool water to loosen mineral buildup. This will temporarily improve performance of the Wicking Filter until a replacement Filter is purchased.

Do not attempt to clean the Wicking Filter with vinegar, soap or any chemical solutions. Doing so may damage the Filter.

Protec antimicrobial layers in the Wicking Filter help to prevent growth of mold on the Filter. However, the Filter still needs to be replaced regularly. Humidifier Filters and accessories require replacement and are not covered under warranty.

It is recommended you change your Wicking Filter every 30-60 days depending on water quality and usage. If you have hard water you may need to replace your Filter more frequently.

Change your Filter if you notice:

- The Filter is hard and crusty
- The Filter starts to give off an odor
- Moisture output is decreased

Be sure to use only genuine Honeywell Replacement Filters which are Protec® antimicrobially treated. It helps prevent the migration of mold, algae and bacteria on the filter.



**Replacement Wicking Filter
Honeywell HC-14 Series, Filter E**

CARING FOR YOUR HUMIDIFIER

To keep your humidifier running efficiently, clean it regularly. Weekly cleaning is recommended. All maintenance should be done in the kitchen or bathroom on a water resistant surface near a faucet. Do not wash any components of this humidifier in a dishwasher.

To properly clean your humidifier we recommend the separate processes of Scale Removal and Disinfecting. These two processes must be done separately.

Before Cleaning

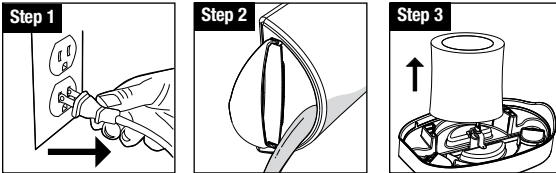

1. Turn off and unplug humidifier. Never clean the humidifier when it is running.
2. Empty water from Water Tanks.
3. Remove Motor Housing, Wicking Filter and any other accessories from humidifier and set aside.

Scale Removal

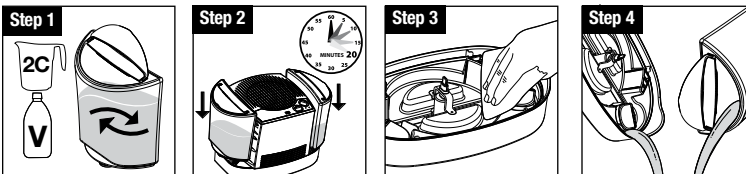

Follow steps 1-3 under Before Cleaning, then follow the additional steps below.

NOTE: Filter must be removed from humidifier during cleaning; do not clean Filter with vinegar.

1. Pour up to 2 cups of undiluted distilled white vinegar into each Water Tank. Swish vinegar around in Tank to wet entire inside of Tank.
2. Place Tanks on Base. Vinegar solution will drain into Water Reservoir and loosen mineral buildup (Scale) in Base, Reservoir and bottom of the two Water Tanks. Allow vinegar to remain in the Tanks and Base for 15-20 minutes.
3. Empty vinegar from Tanks and Base and use a cloth or soft brush to help remove scale.
4. Rinse Base and Reservoir with clean water until the smell of vinegar is gone.

Disinfecting

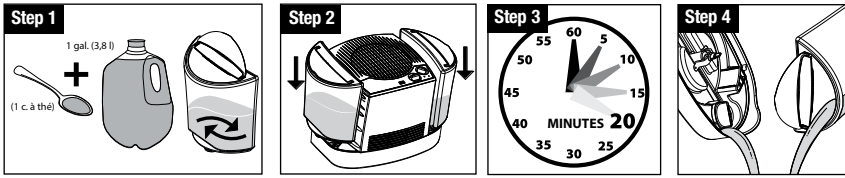

Follow steps 1-3 under Before Cleaning, then follow the additional steps below.

NOTE: Filter must be removed from humidifier during cleaning. Do not clean Filter with bleach solution.

1. Mix 1 gallon (3.8L) of water with 1 teaspoon of bleach. Pour half of the bleach solution into first Water Tank. Lift Tank and swish bleach solution around to wet entire inside of Tank. Repeat for second Water Tank.

NOTE: Using more than 1 teaspoon of bleach to 1 gallon (3.8L) of water may result in damage to the humidifier.

2. Place both Tanks on Base. Bleach solution will drain into Water Reservoir.
3. Allow bleach solution to remain in the Tanks and Base for 15-20 minutes.
4. Empty bleach solution from Tanks and Base. Rinse with clean water until the smell of bleach is gone

NOTE: Consider using a Protec® Cleaning Cartridge to keep your humidifier cleaner longer. It will continuously clean and protect against bacteria and mold. It will also help prevent the buildup of slime in the water and on humidifier surfaces. The Protec Cartridge will keep your humidifier cleaner longer between cleanings. However, your humidifier still needs to be cleaned regularly.



PC-1, PC-2
or PC-1C

End of Season Cleaning

Follow cleaning instructions above when the humidifier will not be used for at least one week, or it is the end of the season. Remove any accessories, including the Wicking Filter, and allow the humidifier to dry completely before storing.

Do not store humidifier with water inside the Base, Water Reservoir or Water Tanks. At end of season, remove and throw away filter. Do not store humidifier with a used Wicking Filter.

TROUBLESHOOTING

Problem	Possible Cause	Solution
Power Knob is turned to high (☸) med (☹) or low (☺) and the Refill light (☸) is off but the unit is not running	Unit is not plugged in	Plug unit in
	No power at outlet	Check home circuits, fuses; test outlet
Power Knob is turned to high, med or low and the Refill light (☸) is on	Set humidity level has been reached (☸) (green light is on)	Turn Humidity Control Knob to a higher setting
	Water level may be low	Check water level and fill if necessary
Water leaking from Base	Motor Housing not properly seated on Base	Set Motor Housing properly on Base
	Plunger Housing is damaged	Contact Consumer Relations for a new Tank
	Plunger is sticking	Push and release Plunger to be sure it is moving freely
	Tank is cracked	Inspect Tank for damage; contact Consumer Relations for a new Tank if necessary
Tank and Base are slimy	Float is not installed properly	Check to make sure Float is snapped properly in place and moves freely
	Plunger Housing has become loose	Tighten Plunger Housing by turning clockwise (to right)
Tank and Base are slimy	Need to clean	See “Caring for your Humidifier”
Fan is running but water level is not going down	Filter is clogged with mineral deposits	See instructions for “Caring for your Filter”; purchase a new Honeywell Replacement Filter
Water is not draining into reservoir	Plunger may be stuck	Push and release Plunger to be sure it is moving freely
Tank Cover snapped off	Used as a handle to carry full Water Tank	Snap Tank Cover back in place

SPECIFICATIONS

Electrical rating: 120V, 60 Hz

Capacity: 3 Gallons (11.4L)

If you experience a problem, please contact Consumer Relations first or check your warranty. Do not return the humidifier to the original place of purchase. Do not attempt to open the motor housing or tamper with the Power Knob yourself. Doing so may void your warranty and cause personal injury or damage to the product.

CONSUMER RELATIONS

For questions, technical support or to order replacement parts contact Consumer Relations. Be sure to specify model number HEV680.

Kaz USA, Inc.
Consumer Relations Department
250 Turnpike Road
Southborough, MA 01772
800-477-0457

consumerrelations@kaz.com

www.honeywellcomfort.com

3 YEAR LIMITED WARRANTY

You should first read all instructions before attempting to use this product.

- A.** This 3 year limited warranty applies to repair or replacement of product found to be defective in material or workmanship. This warranty does not apply to damage resulting from commercial, abusive, unreasonable use or supplemental damage. It also does not apply to the filter or Protec Cartridge. Defects that are the result of normal wear and tear will not be considered manufacturing defects under this warranty.

KAZ USA, INC. IS NOT LIABLE FOR INCIDENTAL OR CONSEQUENTIAL DAMAGES OF ANY NATURE. ANY IMPLIED WARRANTY OF MERCHANTABILITY OR FITNESS FOR A PARTICULAR PURPOSE ON THIS PRODUCT IS LIMITED IN DURATION TO THE DURATION OF THIS WARRANTY.

Some jurisdictions do not allow the exclusion or limitation of incidental or consequential damages or limitations on how long an implied warranty lasts, so the above limitations or exclusions may not apply to you. This warranty gives you specific legal rights, and you also may have other rights which vary from jurisdiction to jurisdiction. This warranty applies only to the original purchaser of this product from the original date of purchase.

- B.** At its option, Kaz USA, Inc. will repair or replace this product if it is found to be defective in material or workmanship.
- C.** This warranty does not cover damage resulting from any unauthorized attempts to repair or from any use not in accordance with the instruction manual.
- D.** Return defective product to Kaz USA, Inc. with a brief description of the problem. Include proof of purchase and a \$10 US/\$15.50 CAN check or money order for handling, return packing and shipping charges. Please include your name, address and a daytime phone number.

You must prepay shipping charges.

We suggest having tracking or delivery confirmation. Send to:

In U.S.A.:

Kaz/ Helen of Troy
Attn: Returns Department
1 Helen of Troy Plaza
El Paso, TX 79912
USA

In Canada:

Kaz Canada, Inc.
Attn: Returns Department
510 Bronte Street South
Milton, ON L9T 2X6
Canada

Please go to www.honeywellcomfort.com and register your product under the Customer Support section and receive product information updates and new promotional offers.

In US

For responsible recycling, please visit:

1-800-RECYCLING.com®

www.1800recycling.com

© 2015 Kaz USA, Inc. All Rights Reserved.

Manufactured by Kaz USA, Inc.

250 Turnpike Rd.

Southborough, MA 01772

Distributed by Kaz Canada, Inc.

510 Bronte St. S., Milton, ON L9T 2X6

www.honeywellcomfort.com

consumerrelations@kaz.com

Honeywell is a trademark of Honeywell International Inc. used under license by Helen of Troy Limited.
Honeywell International Inc. makes no representation or warranties with respect to this product.

Free Manuals Download Website

<http://myh66.com>

<http://usermanuals.us>

<http://www.somanuals.com>

<http://www.4manuals.cc>

<http://www.manual-lib.com>

<http://www.404manual.com>

<http://www.luxmanual.com>

<http://aubethermostatmanual.com>

Golf course search by state

<http://golfingnear.com>

Email search by domain

<http://emailbydomain.com>

Auto manuals search

<http://auto.somanuals.com>

TV manuals search

<http://tv.somanuals.com>