

OPERATING INSTRUCTIONS AND PARTS LIST INSTRUCCIONES DE OPERACION Y LISTA DE PIEZAS



Dual Trac Surface Grinder Electric & Gasoline Models

MODELS: DT15E (1-1/2 HP Electric)
DT11H (11 HP Honda Gasoline)

Effective With Serial No. 308084 and Later

Model: _____

Serial Number: _____

Engine / Motor Serial No.: _____

Purchase Date: _____

This Document Supersedes All Earlier Dated Documents.

0A7796
© February 5, 2001
Printed in U.S.A.



17400 West 119th Street
Olathe, Kansas 66061, USA

Customer Service 800-288-5040
Corporate Office 913-928-1000
Customer Service FAX 800-825-0028
Corporate Office FAX 913-438-7951
International FAX 913-438-7938

Internet ... www.targetblue.com

BEFORE YOU BEGIN: Read and understand all warnings and instructions before operating the Machine described in this manual. **WARNINGS AND CAUTIONS IN THIS MANUAL MUST BE UNDERSTOOD AND FOLLOWED!**
FAILURE TO OBEY WARNINGS MAY RESULT IN SERIOUS INJURY OR DEATH. IT IS YOUR RESPONSIBILITY
to make sure persons who use this machine have read this manual.

CONTENTS	Page
Symbol Definitions (English & Spanish).....	3 - 4
Hearing Hazard Warnings (English & Spanish).....	5
Decals -Descriptions and Locations (English & Spanish)	6
Figures: FIG. 1 - FIG. 33 (English and Spanish)	7 - 10
Parts Identification (English and Spanish).....	11
English Language Section:	
SAFETY WARNINGS - DO's & DO NOT's	12 - 13
Specifications & Power Sources	14
Unit Dimensions	15
Tool Application Guide	16
Pre-Operation Checklist & Scheduled Maintenance Quick Reference.....	17
English Instructions:	
1 - Features, 2 - Assembly	18
3 - Check before Operating.....	18 - 20
4 - Tool Installation	20 - 22
5 - Operating Instructions.....	22 - 23
6 - Incidents During Operation	23
7 - Maintenance	23 - 24
8 - V-Belt Tension.....	24
9 - Important Advise	24 - 25
10 - Accessories, 11 - Repairs, 12 - Spare Parts	25 - 26
Spanish Language Section (Not Available at This Time)	xx – xx
Parts List: Figures 1 - 15 (Text In English Only).....	27 - 49
Wiring Diagram for 1.5 hp Electric Model – Diagram 15 (Text In English Only)	49



SYMBOL DEFINITIONS DEFINICIÓN DE SIMBOLOS



- Please read the instructions for use prior to operating the machine for the first time.
- Antes de la puesta en marcha, lea detenidamente las instrucciones y familiarícese con la máquina.



- Mandatory
- Obligatorio



- Indication
- Indicación



- Prohibition
- Prohibición



- Warning Triangle
- Triángulo De Advertencia



- Wear Eye Protection
- Usar Gafas De Protección



- Wear Head Protection
- Usar Casco De Protección



- Wear Breathing Protection
- Usar Máscara De Protección



- The Use Of Ear Protection Is Mandatory
- Es Obligatorio El Uso De Protección Auditiva



- Wear Safety Shoes
- Usar Zapatos De Seguridad



- Wear Appropriate Clothing
- Usar Ropa Adecuada



- Motor Off
- Parar El Motor



- Use In Well Ventilated Area
- Usar En Una Área Bien Ventilada



- Do Not Use In Flammable Areas
- No Usar In Áreas Inflamables



- Machinery Hazard, Keep Hands And Feet Clear.
- Máquina Peligrosa - Mantenga Manos Y Pies Alejados De La Máquina



- Danger, Poison Exhaust Gas
- Peligro, Gases De Escape Tóxicos



- No Non-working Personnel In Area
- Prohibido Para Personas Ajenas A La Obra



- No Smoking
- No Fumar



- Do Not Operate Without All Guards In Place
- No Operar Sin Todas Las Protecciones In Su Sitio



- Always Keep the Blade Guards In Place
- Mantenga Siempre Las Protecciones De La Hoja En Su Sitio



- Keep Work Area Clean/Well Lit, Remove All Safety Hazards
- Mantenga Limpio El Sitio De Trabajo/Bien Iluminado, Elimine Todos Los Riesgos De Seguridad



- Dangerously High Noise Level
- Nivel De Ruido Elevadamente Peligroso



- Pay Extreme Attention To The Care And Protection Of The Machine Before Starting Up
- Ponga Extrema Atención Al Cuidado Y Preparación De La Máquina Antes De Ponerla En Marcha



- Remove Tools From Area and Machine
- Elimine Las Herramientas Del Área Y De La Máquina



- Oil Required
- Necesita Aceite



- Dipstick, Maintain Proper Oil Level
- Varilla De Control, Mantenga El Nivel De Aceite Correcto

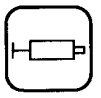

- Lubrication Point
- Punto De Lubrication



- Unleaded Fuel Only
- Solamente Combustible Sin Plomo



- Repairs Are To Be Done By An Authorized Dealer Only
- Las Reparaciones Deben Ser Efectuadas Únicamente Por Un Distribuidor Autorizado

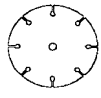

- Diamond Blade
- Sierra Diamantada



- Blade Diameter
- Diámetro De La Hoja



- Muffler Hot. May Cause Burns and / or Ignition Of Material. Avoid Contact.
- --

WARNING

HEARING HAZARD

DURING NORMAL USE OF THIS MACHINE, OPERATOR MAY BE EXPOSED TO A NOISE LEVEL EQUAL OR SUPERIOR TO **85 dB (A)**

ATENCION

RIESGO DE DAÑO AUDITIVO

EN CONDICIONES NORMALES DE UTILIZACIÓN, EL OPERADOR DE ESTA MÁQUINA PUEDE ESTAR EXPUESTO A UN NIVEL DE RUIDO IGUAL O SUPERIOR A **85 dB (A)**

DECAL DESCRIPTIONS AND LOCATIONS DESCRIPCIÓN DE CALCAMONIAS Y UBICACIONES



P/N: 187684

Decal: Target Dual Trac
Location: Handle Sides (2)
Quantity: 2 (All Models)



P/N: 177857

Decal, Operating Instructions
Location: Top Of Adjustable Handle
Quantity: 1 (All Models)



P/N: 189732

Decal, Target-LB 1.00
Location: Front Of Gearbox Cover (1),
Rear Of Adjustable Handle (1)
Top RH of Adjustable Handle (1)
Quantity: 3 (All Models)



P/N: 169065

Decal, Muffler Hot
Location: On Engine
Quantity: 1 (Gasoline Model Only)



P/N: 176223

Decal, Warning
Location: On Frame Behind Front Shield (1),
Under Gearbox Cover On Top Of Gearbox (1)
Quantity: 2 (All Models)

Figures / Figuras

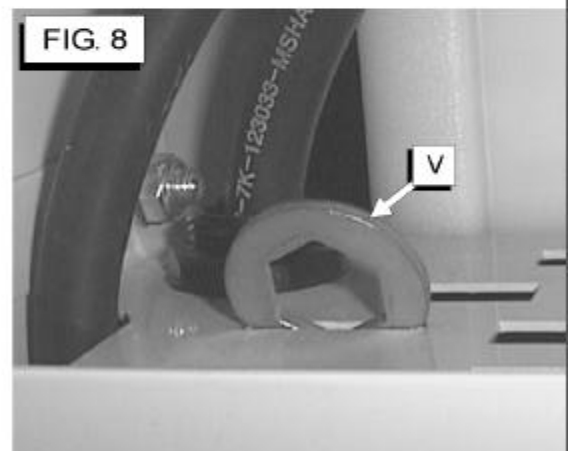
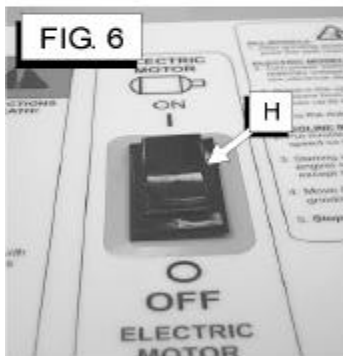
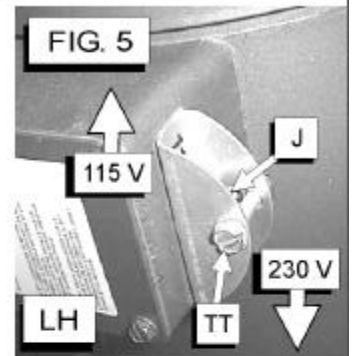
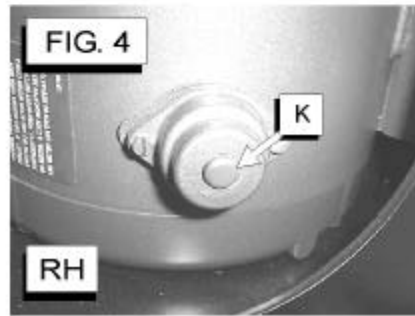
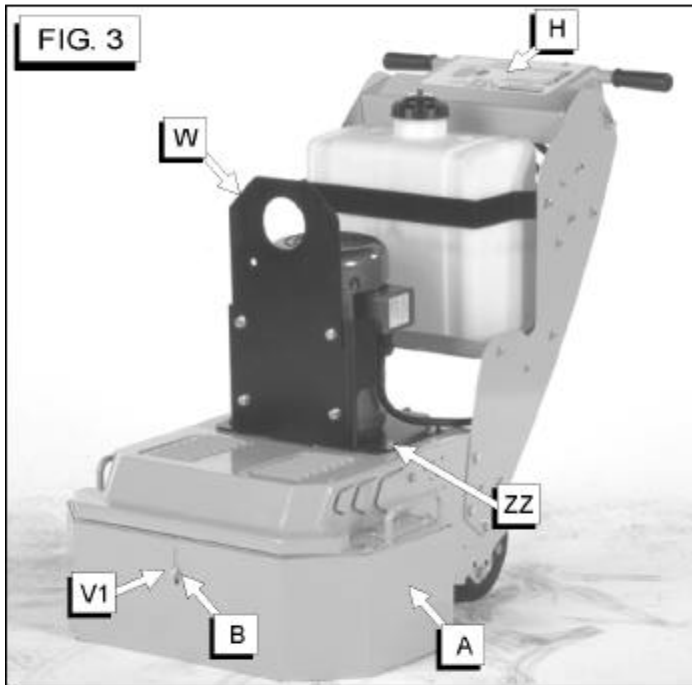
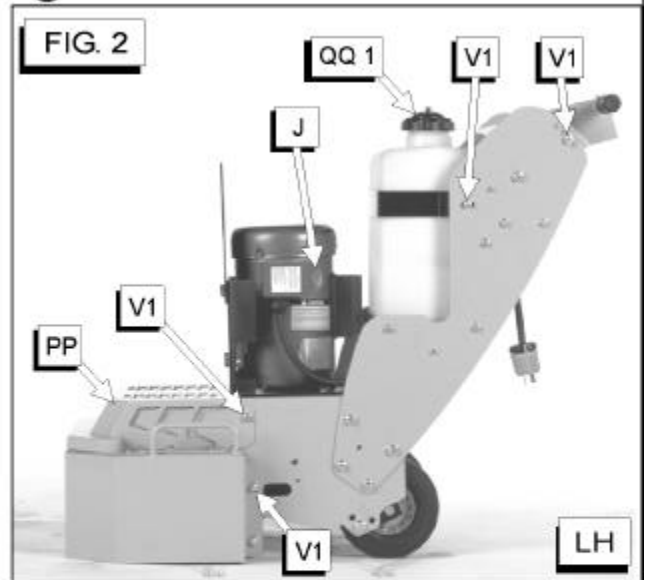
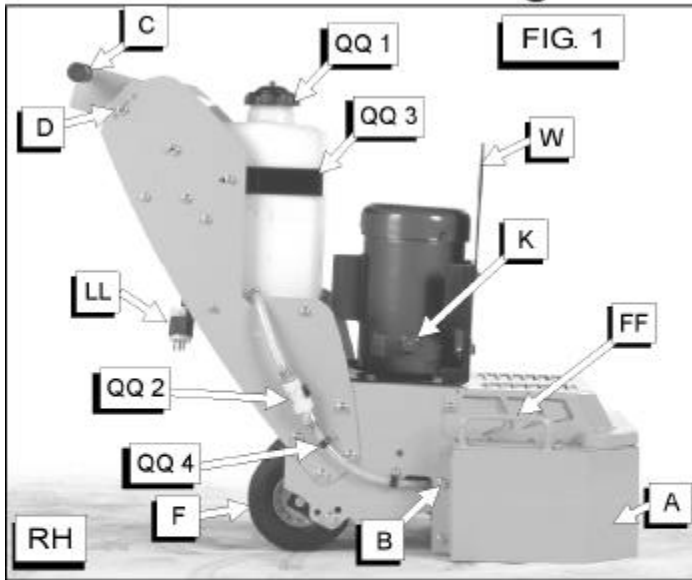

Figures / Figuras

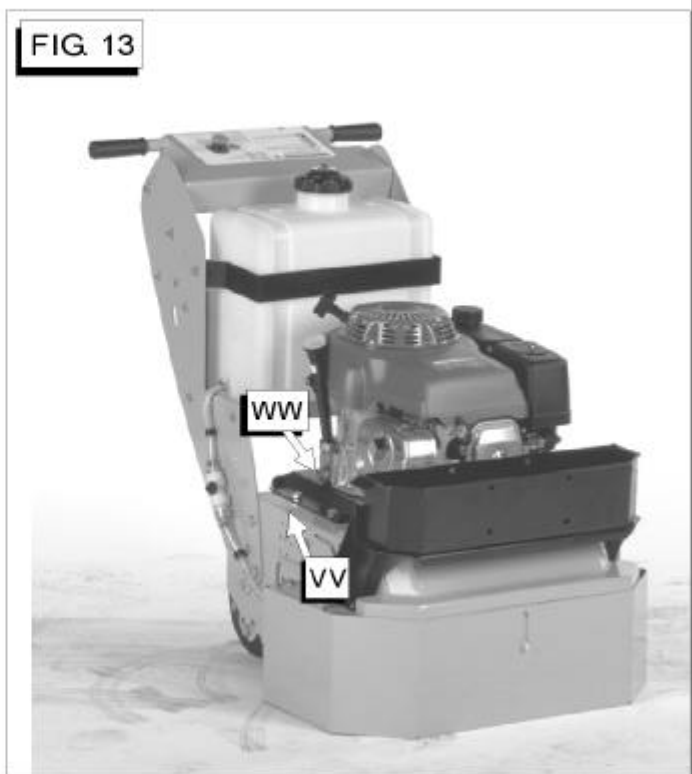
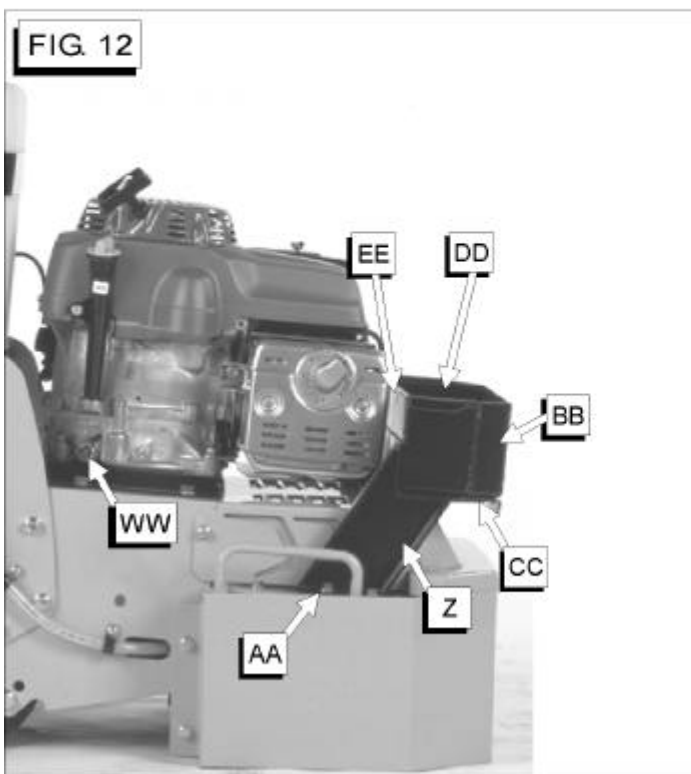
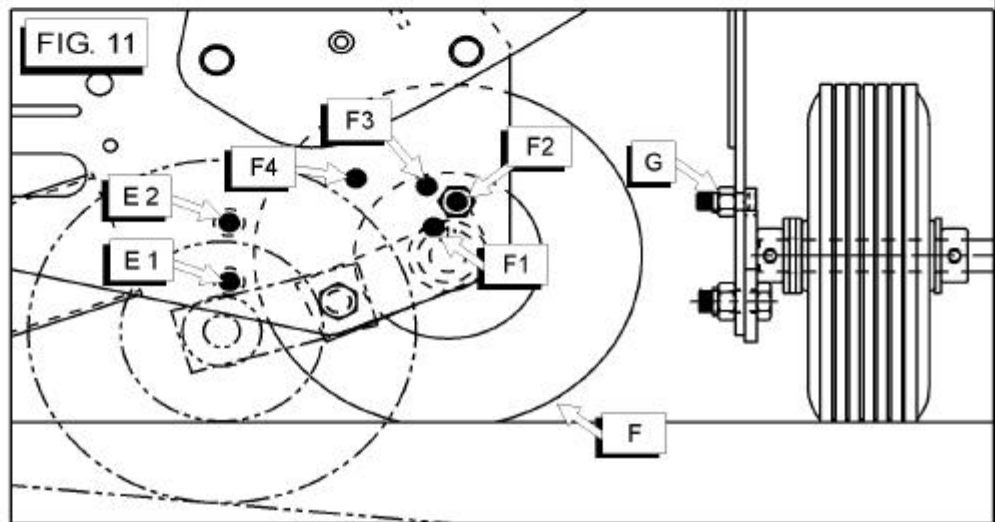
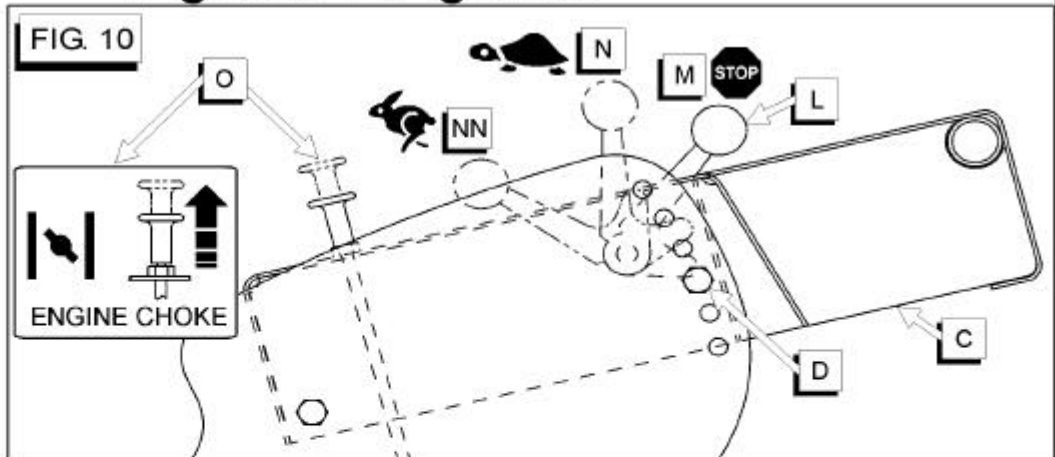
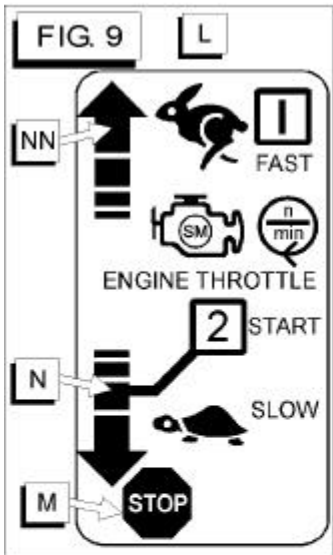

Figures / Figuras

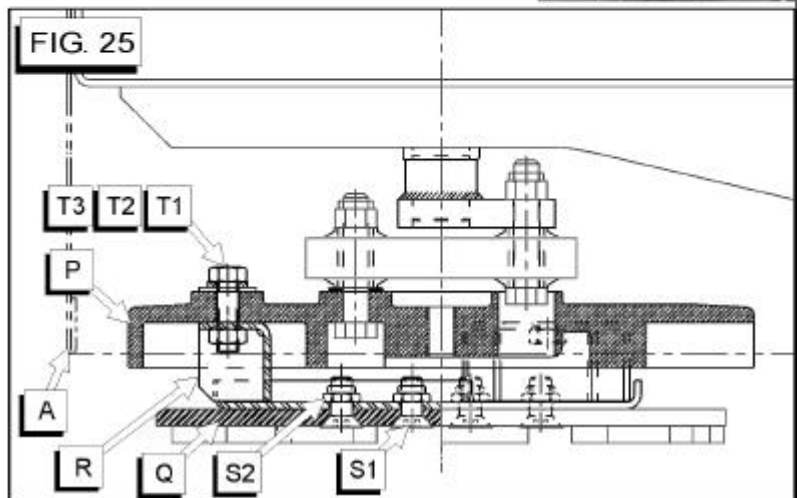
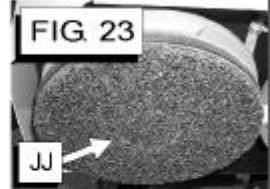
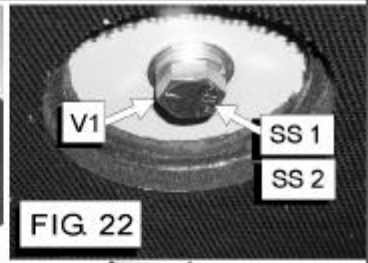
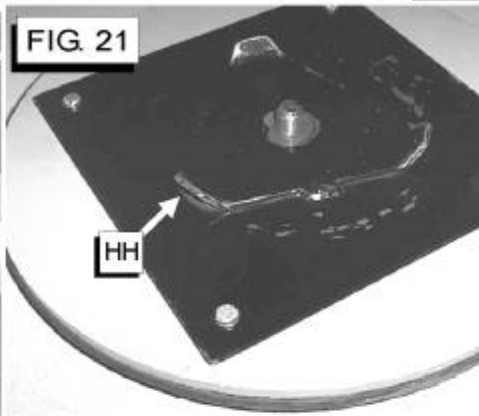
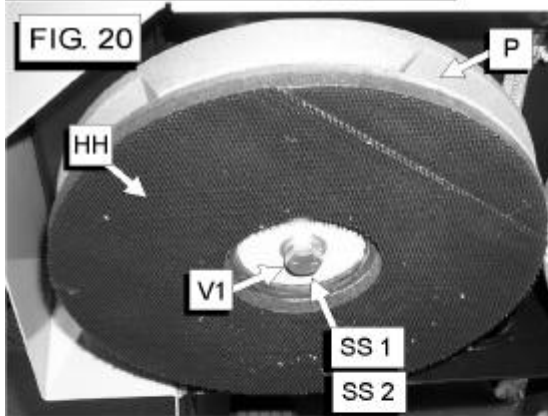
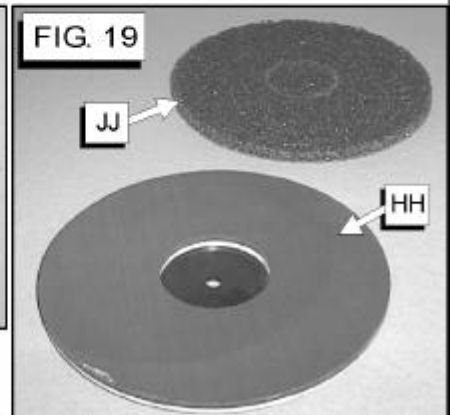
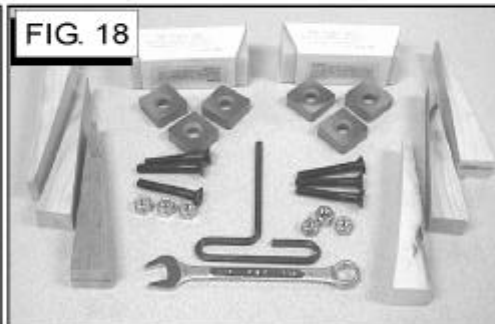
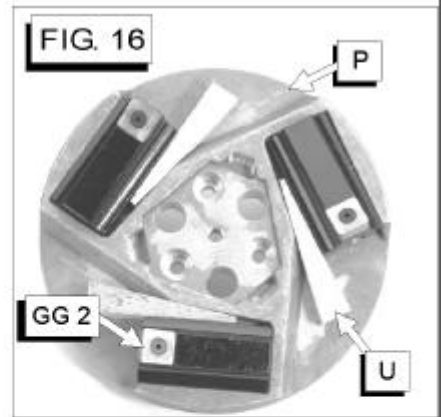
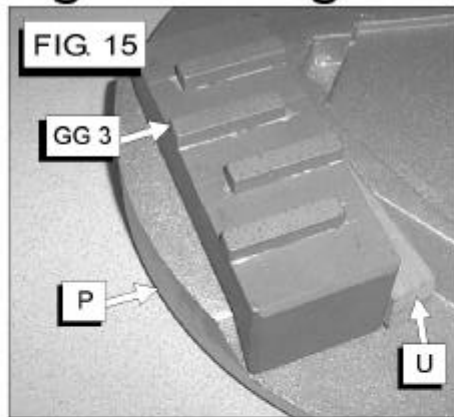
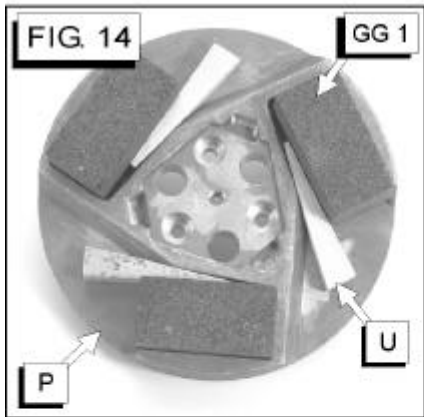

Figures / Figuras

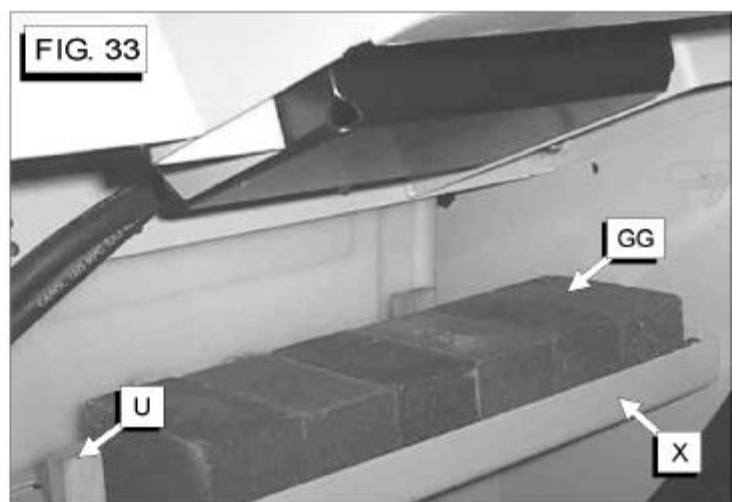
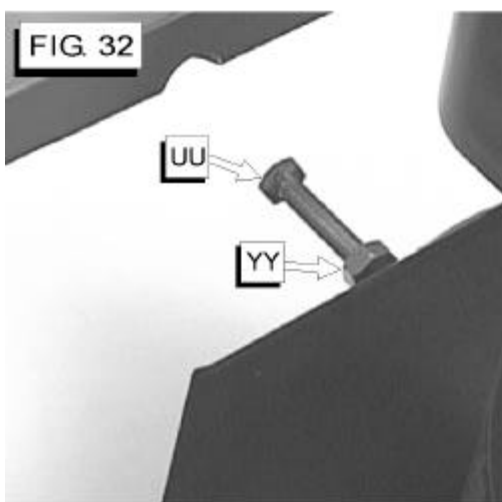
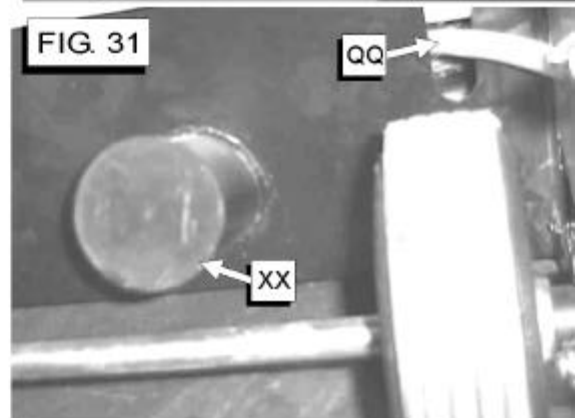
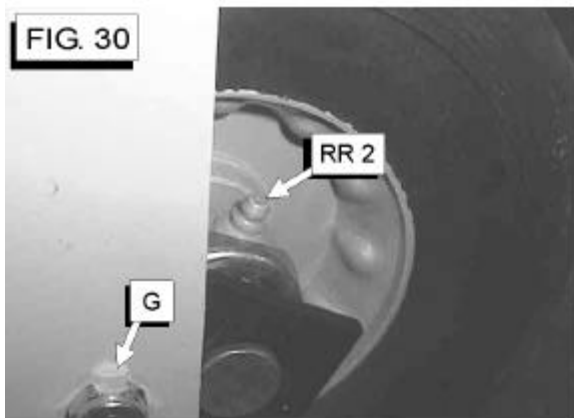
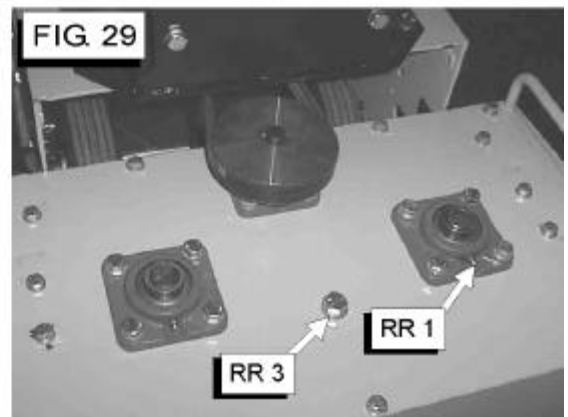
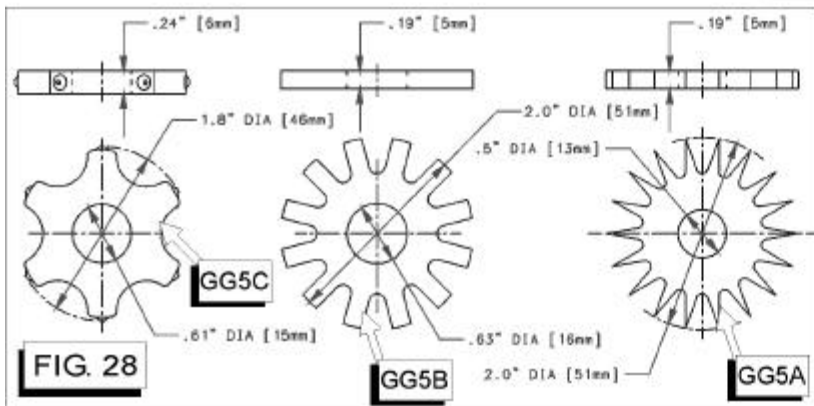
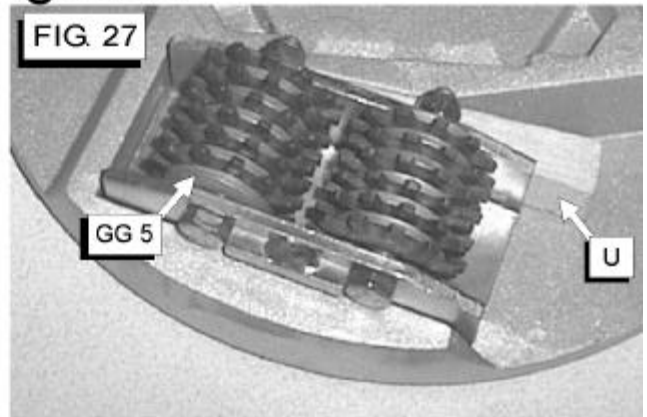
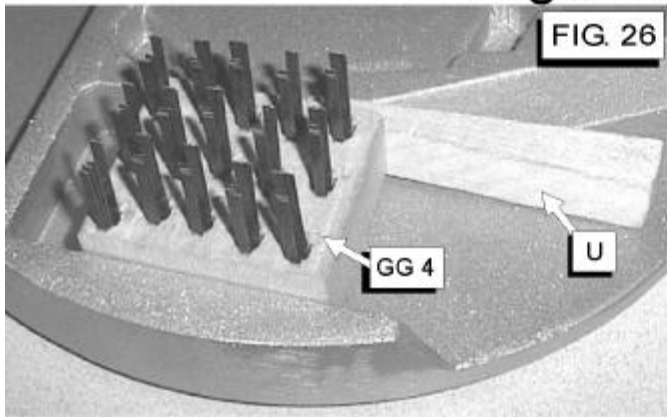

Parts Identification:

- A. Front Shield [FIG. 1].
- B. Front Shield Bolts [FIG. 1, FIG. 3].
- C. Adjustable Handle [FIG. 1].
- D. Handle Bolts [FIG. 1].
- E. Axle In Transport Position [FIG. 11].
- F. Axle In Operation Position [FIG. 11].
- G. Axle Stop Bolt [FIG. 11, FIG. 30].
- H. Electrical ON / OFF Switch (Electric Model Only) [FIG. 6].
- I. -----
- J. Voltage Change Switch (Electrical Model Only) [FIG. 5].
- K. Reset Button (Electrical Model Only) [FIG. 4].
- L. Throttle Lever (Gasoline Model Only) [FIG. 10].
- M. Engine STOP Position (Gasoline Model Only) [FIG. 10].
- N. Engine START Position (Gasoline Model Only) [FIG. 10].
- O. Engine Choke (Gasoline Model Only) [FIG. 10].
- P. Accessory Disks [FIG. 20, FIG. 14, FIG. 15, FIG. 16].
- Q. Multi-Segmented Diamond Disks [FIG. 24, FIG. 25].
- R. Diamond Disk Adapter [FIG. 25].
- S. Diamond Disk Attaching Hardware [FIG. 25].
 - S1. Flat Head Screws.
 - S2. Locknuts.
- T. Diamond Disk Adapter Attaching Hardware [FIG. 25].
 - T1. Capscrew, 3/8-16UNC x 1-1/2" Long.
 - T2. Lockwasher 3/8", Split Type.
 - T3. Washer, .3/8 SAE.
- U. Wooden Wedges [FIG. 14, FIG. 15, FIG. 16].
- V. Wrench, 1/2" (13 mm) x 3/4" (19 mm) [FIG. 8]
 - V1. Wrench Can Be Used On Items Marked "V1" [FIG 2, FIG. 3, FIG 20].
- W. Lifting Eye (Electrical Model Only) [FIG. W].
- X. Tool Storage Area: Holds 6 Extra 2 x 2 x 4" Tools [GG], & 9 Extra Wooden Wedges [U]. [FIG. 33].
- Y. Lifting Bail – Standard Equipment for Gas Model.
- Z. Weight Tray (FIG. 12)
- AA. Weight Tray Hardware – With Optional Weight Kit [FIG. 12]
- BB. Weight Box – With Optional Weight Kit [FIG. 12]
- CC. Hold Down Bolts (Weight Box) [FIG. 12].
- DD. Weight Bar [FIG. 12].
- EE. Weight Bar Attaching Hardware [FIG. 12].
- FF. Lifting Handles [FIG. 1].
- GG. Tool (2 x 2 x 4" Type):
 - GG1. Grinding Block [FIG. 14].
 - GG2. Tungsten Carbide Segment Block [FIG. 16].
 - GG3. Diamond Blocks [FIG. 15].
 - GG4. Wire Brushes [FIG. 26].
 - GG5. Scarifier Wheels [FIG. 27].
 - GG5A. Star Wheel [FIG. 28].
 - GG5B. Beam Wheel [FIG. 28].
 - GG5C. Tungsten Carbide Wheel [FIG. 28].
- HH. Tool Holding Pad [FIG. 19, FIG. 20, FIG. 21].
- II. -----
- JJ. Scrubbing Pad [FIG. 19].
- KK. -----
- LL. Electrical Plug [FIG. 1].
- MM. Ground Fault Circuit Interrupter (GFCI) [FIG. 7].
- NN. Engine "Fast" Speed (Gas Model Only) [FIG. 10].
- OO. -----
- PP. Gearbox Cover [FIG. 2].
- QQ. Water Tank Kit [FIG. 2].
 - QQ1. Tank with Lid [FIG. 1].
 - QQ2. Water Tank [FIG. 1].
 - QQ3. Water Tank Bracket [FIG. 1].
 - QQ4. Hose Clamps [FIG. 1].
- RR. Lubrication Points:
 - RR1. Spindle Bearings [Six (6) Places] [FIG. 29].
 - RR2. Rear Wheels [FIG. 30].
 - RR3. Gearbox Grease Port [FIG. 29].
- SS. Tool Holding Pad Attaching Hardware [FIG. 20, FIG. 22, FIG. 25].
 - SS1. Capscrew, Hex Hd, .500-20UNC x 1.25".
 - SS2. Lockwasher, .500", Split Type.
- TT. Voltage Change Lock Bolt [FIG. 5].
- UU. Belt Tensioning Drawbolt [FIG. 32].
- VV. Serial Number Plate [FIG. 13].
- WW. Oil Drain Hose [FIG. 12, FIG. 13].
- XX. Dust Port Cap [FIG. 31].
- YY. Belt Tensioning Jam Nut [FIG. 32].
- ZZ. Motor Platform Capscrews [FIG. 3].
- AAA. Hose Port Cover [FIG. 31].

SAFETY WARNINGS FOR OPERATION OF THIS MACHINE

- DO** read this entire operator's manual before operating this machine. Understand all warnings, instructions, and controls.
- DO** keep all guards in place and in good condition.
- DO** wear safety-approved hearing, eye, head and respiratory protection.
- DO** read and understand all warnings and instructions on the machine.
- DO** read and understand the symbol definitions contained in this manual.
- DO** keep all parts of your body away from the grinding disks and all other moving parts.
- DO** know how to stop the machine quickly in case of emergency.
- DO** shut off the engine and allow it to cool before refueling.
- DO** inspect the accessory disk, and tool adapters for damage before installing the tools.
- DO** use only tools manufactured for use on surface grinders.
- DO** verify grinder drive configuration by checking engine / motor RPM, and spindle shaft RPM, pulley diameters.
- DO** read all safety materials and instructions that accompany any tool used with this machine.
- DO** inspect each tool carefully before using it. If there are any signs of damage or unusual wear, **DO NOT USE THE TOOL!**
- DO** mount the tool solidly and firmly.
- DO** make sure the tool and accessory disk are clean and free of dirt and debris before mounting the tool on the saw.
- DO** use the correct tool for the type of work being done. Check with tool manufacturer if you do not know if tool is correct.
- DO** operate this machine only in well ventilated areas.
- DO** instruct bystanders on where to stand while the machine is in operation.
- DO** establish a training program for all operators of this machine.
- DO** clear the work area of unnecessary people. Never allow anyone to stand in near the machine while the engine is running.
- DO** always tie down the machine when transporting.
- DO** use caution and follow instructions when setting up or transporting the machine.
- DO** have all service performed by competent service personnel
- DO** verify that the tool size is compatible with the machine before mounting the tool.
- DO** make sure the fuel caps of the machine and the fuel can are properly tightened before starting the engine. Move fuel can at least 10 feet from machine after fueling.
- DO** clean the machine after each day's use.
- DO** remove adjusting tool and wrenches from machine before turning it on.
- DO** keep the handles dry, clean and free of oil and dirt.
- DO** carefully maintain and clean for better and safer performance. Follow instructions for changing accessories. Inspect tool cords periodically and, if damaged, have repaired by authorized service facility.
- DO** use caution when handling fuel.
- DO** always give a copy of this manual to the equipment user. If you need extra copies, call TOLL FREE 1-800-288-5040.
- DO** Determine the nature and volatility of any material that will come in contact with the grinding action of the tools used by this machine.
- DO** operate the machine only in areas where the material in contact with the grinding tools is known.
- DO** use only non-flammable and proper substances to improve the material removal from the work area.

- DO NOT** operate this machine unless you have read and understood this operator's manual.
- DO NOT** operate this machine without all guards in place.
- DO NOT** leave this machine unattended while the engine or motor is running.
- DO NOT** work on this machine while the engine or motor is running.
- DO NOT** operate this machine when you are tired or fatigued.
- DO NOT** operate the machine if you are uncertain of how to run the machine.
- DO NOT** use damaged equipment or tool.
- DO NOT** touch or try to stop a moving tool with your hand.
- DO NOT** transport a machine with the tools mounted on the machine.
- DO NOT** use a tool that has been dropped or damaged
- DO NOT** touch the tools immediately after use. These tools require several minutes to cool after operation.
- DO NOT** use damaged or worn accessory disk.
- DO NOT** allow other persons to be near the machine when starting, refueling, or when the machine is in operation.
- DO NOT** operate this machine in an enclosed area unless it is properly vented.
- DO NOT** operate this machine in the vicinity of anything that is flammable. Sparks could cause a fire or an explosion.
- DO NOT** operate this machine while under the influence of drugs or alcohol.
- DO NOT** operate this machine with any of the guards removed.
- DO NOT** operate this machine unless you are specifically trained to do so.
- DO NOT** start operation of the machine until you have a clear work area and secure footing.
- DO NOT** use flammable substances, unsecured loads or people as extra weight. Injury to the operator or other persons could result!
- DO NOT** use flammable, or improper substances to improve the material removal from the work area.
- DO NOT** operate the machine if unknown substances are on or near the work area.
- DO NOT** operate the machine before you determine the nature and volatility of any material that will come in contact with the grinding tools used by this machine.

This machine was designed for certain applications only. DO NOT modify this machine or use for any application other than for which it was designed. If you have any questions relative to its application, DO NOT use the machine until you have written Diamant Boart, Inc. and we have advised you.

**Diamant Boart Inc.
17400 West 119th Street
Olathe, Kansas 66061, USA**

TARGET® Dual Trac SPECIFICATIONS

FEATURE	MODEL	
Model Number:	DT15E	DT11H
Item Number:	F60000	F60001
Power Source:	Electric	Gasoline
Maximum Horsepower:	1-1/2 (1,1 kw)	11 (8,2 kw)
Motor / Engine Rated RPM:	1725	3600
Brand:	Baldor	Honda
Model / Specification:	TEFC	GXV340
Voltage:	115 / 230	-----
Phase:	Single	-----
Full Load Current @ 115V:	19	-----
Full Load Current @ 230V:	9.5	-----
Displacement:	-----	20.6 cubic inches (338 cc)
Bore:	-----	3.2 inch (82 mm)
Stroke:	-----	2.5 inch (64 mm)
Cylinders:	-----	1
Fuel Capacity:	-----	.61 US Gallon (2,3 Liter)
Oil Capacity:	-----	1.16 US Quart (2.32 US Pints) (1,09 Liter)
Air Filter:	-----	Dual Element: Pleated Paper & Foam Pre Cleaner
Starter:	Capacitor	Recoil
Coolant:	Air	Air
Spindle Shaft RPM:	230	279 – 560 (Variable Speed Using Engine Throttle)
Clutch Engagement RPM:	N/A	1800
Nominal Weight:	309 Lb. (140 kg)	328 Lb. (149 kg)
Operating Weight (With Tools, Fuel, Oil, Etc):	320-350 Lb. (145-159 kg)	340-370 Lb. (154-168 kg)
Grinding Width:	22.2 inches (56,4 cm)	
Gearbox Ratio:	4.48 : 1	
Handle:	Six (6) Position Adjustment with Rubber Grips	
Dust Port:	3.0" (76,2 mm) Outside Diameter will accept 3" (76mm) Inside Dia. Flex Hose	
Tires & Wheels:	8" Diameter, 3/4" Bore, Semi-Pneumatic, Steel Wheel with Roller Bearings & Grease Fitting	
Axle:	3/4" Diameter, Zinc Plated with One Transport & Four (4) Operation Positions	
Tool Storage Area (See FIG. 33):	Holds Six (6) Extra Tools (2 x 2 x4") and Nine (9) Extra Wooden Wedges	
OPTIONS:		
Water Tank Kit (P/N 177855):	Plastic, 7.5 Gallon (28.4 Liter), Quick-Connect ON/OFF Valve, Brass Fittings & Spray Nozzle, Weight 6.5 Lbs. (2,9 kg) Less Water	
Weight Kit (P/N 177856):	Includes Weight Tray, Removable Weight Box, & 58 Lbs. (26 kg) of Steel Weights. Can Hold an additional Nine (9) Weight bars (Sold Separately) [58 Lbs. (26 kg)] for a Total Maximum Weight of 117 Lbs. (53 kg)	
Lift Bail Kit (P/N 177901): (For Gas/Electric Models)	One Point Lifting, 7 Ga. x 1.5" (38 mm) Steel, Weight 14 Lbs. (6,3 kg) Gas Model: Standard Equipment Beginning Spring 2000. Electric Model: Lifting Eye (Standard Equipment), but this Kit Will Fit.	
Diamond Disk Adapter Kit (P/N 177861):	Attaches Two (2) 10" (254mm) Diameter Diamond Disks To the Machine. Kit Includes adapter disks and all attaching hardware. Diamond Disks must be purchased separately.	

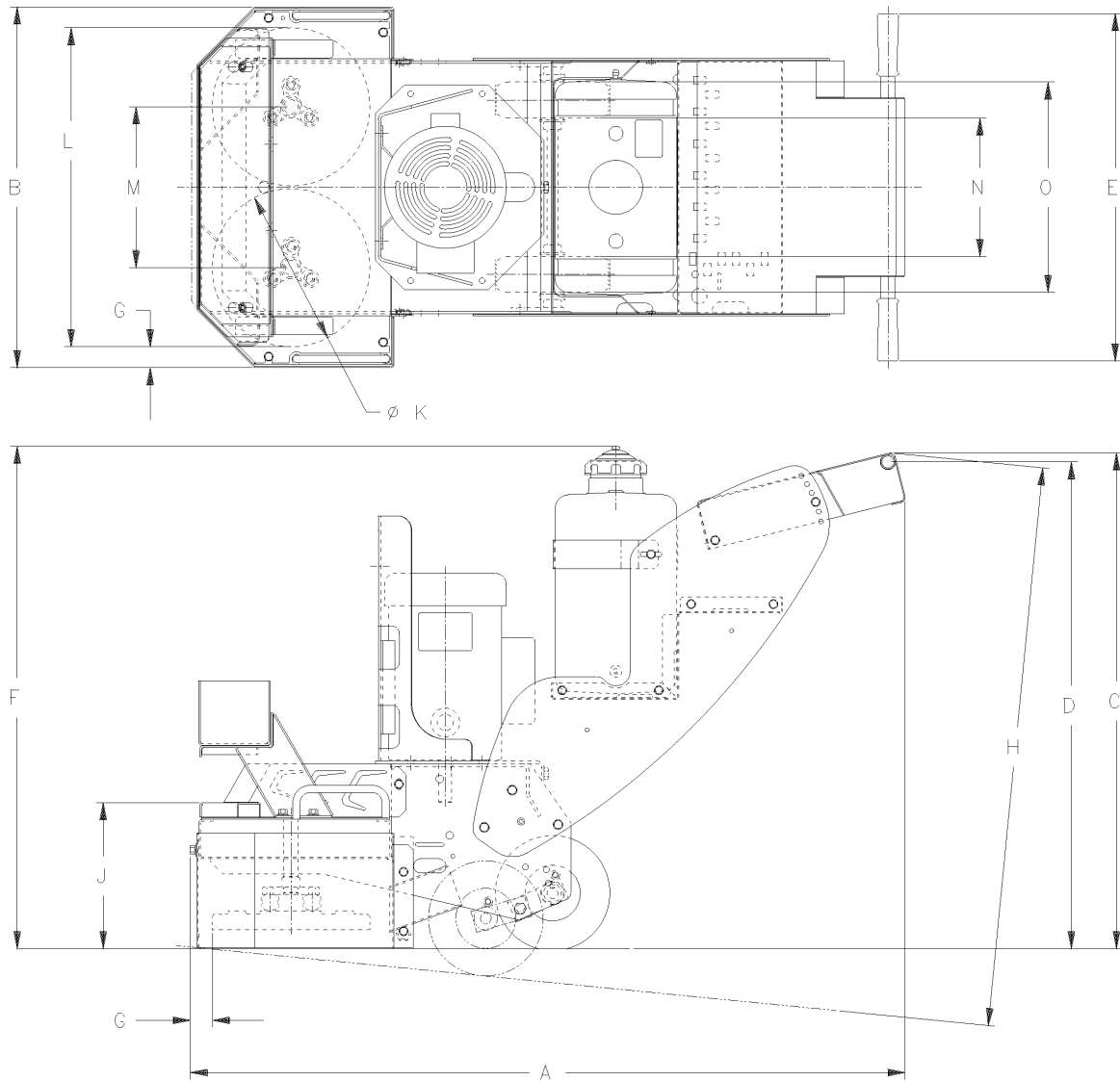

(DT15_dims.tif)

Dimensions (Note 1)

Item	Length (cm)	Description
A	50.2" (127.5)	Length – Maximum (With Handle In Low Position)
B	25.12" (63.8)	Width
C	37.6" (95.5)	Operating Height (Maximum – Note 1)
D	37.0" (94.0) – 31.5" (80.0)	Handle Height (Maximum – Minimum)
E	24.2" (61.5)	Handle Width
F	35.0" (88.9)	Water Tank Height
G	1.50" (3.8)	Grind To Wall (Front and Side)
H	41.9 (106.5)	Transport Height (Maximum – Note 2)
J	10.2" (25.8)	Front Height
K	11.0" (27.9)	Disk Diameter
L	22.2 (56.4)	Grinding Width
M	11.200 (28.45)	Spindle Center Distance
N	9.6" (24.4)	Width Inside Tires
O	14.6" (37.0)	Width Outside Tires

Notes:

1. Dimensions are for the machine with the axle in "operation" position unless otherwise specified.
2. Dimension "H" is for the machine with the axle in "Transport" position.

Tool Application Guide			
Tool	Attachment To Machine	Task	Surface Material
Grinding Stones (See FIG. 14) See Current Product Catalog for Part Numbers of these Items.	Accessory Disk and Wooden Wedges (Section 4.1)	Light Grinding of Rough Areas Available In Different Silicon Carbide "Grit" Sizes, such as: TSC-10 Coarse Grit: Maximum material removal, General grinding & removal of trowel marks, high spots, and rough sections of concrete. Life 4-10 hours. TCS-24 Medium Grit: Lower material removal rate, Finer finish grinding of concrete, and rough grinding of Terrazzo and other stone type. Life 6 – 10 hours. TCS-80 Fine Grit: Still lower material removal rates. For polishing of concrete and medium grinding on Terrazzo and stone type floors. Life 8 – 20 hours. (The larger the number, the finer the grain structure, and the smoother the surface material finish, and the longer the grinding stone life)	Concrete Terrazzo Other Stone Types
Diamond Segment Blocks (See FIG. 15) See Current Product Catalog for Part Numbers of these Items.	Accessory Disk and Wooden Wedges (Section 4.2)	Remove High Spots, Trowel & Rain Marks, Paints, Sealers & Mastics, Uneven Joints, Aggressive Grinding of Large Rough Areas, Removal of epoxies, paints and many thin film coatings, or Final Preparation for new coating. Available In Different "Grit" Sizes: GB-10 General Purpose, GB-20 Abrasive Materials GB-30 Epoxy & Non-Abrasive Materials. Removal Rates: Up to five (5) times the material removal rate of Coarse Grinding Stones. Life: Up to 15 times the life of Grinding Stones.	Concrete Terrazzo Other Stone Types
Tungsten Carbide Blocks (FIG. 16, FIG. 17, FIG. 18)	Accessory Disk and Wooden Wedges (Section 4.3)	Removal of Thick Paint Coatings, Not Recommended for Thin (< 5 mil) Films of Materials. Not Recommended for adhesive, rubber deposits and mastics which have a tendency to extrude or smear rather than "shear" loose from the floor surface – however water or a water / sand mixture can be added on the surface to reduce this problem.	Concrete, Epoxy, Coatings, & Mastics
Scarifier Wheels (FIG. 27, FIG. 28) See Current Product Catalog for Part Numbers of these Items.	Accessory Disk and Wooden Wedges (Section 4.4)	Remove Fiberglass, Ice, Oil-Dry, Foam-Fill Packing Material & Floor Buildups. Lightly Texture Surface. Star Wheel: Hardened Carbon Steel material. For removal of thin coatings and encrusted accumulations of material. Cleaning concrete of asphalt surfaces. Removing thick build-up of grease, paint, and some resins. Light scarifying before application of coatings or sealer. Creates a swept, or "broomed" type of finish. Beam Wheel: Medium duty, for concrete and asphalt scarifying. De-scaling steel decks. Removing thick material build-up of grease, paint, and some resins. Twice the life, near the same cost as a star wheel. Tungsten Carbide Wheel: Heavy Duty asphalt or concrete scarifying, or de-scaling of steel decks. 10 times the life of a star wheel.	Concrete, and Tile
Wire Brushes (FIG. 26)	Accessory Disk and Wooden Wedges (Section 4.5)	Light Scarifying & cleaning. Notes: Should be rotated end for end in accessory disk every hour to avoid the wire taking a set (flat wire will bend in one direction). External weight added to machine will NOT normally increase production rates, but only accelerate the wire brush wear rates.	Concrete, Asphalt, Steel, and Tile
Diamond Disks (FIG. 25) See Current Product Catalog for Part Numbers of these Items.	Adapter Plates (Section 4.6)	Remove High Spots, Trowel & Rain Marks, Paints, Sealers & Mastics, Uneven Joints, Aggressive Grinding of Large Rough Areas, Removal of epoxies, paints and many thin film coatings, or Final Preparation for new coating. Available In Different "Grit" Sizes and 10 or 20 Diamond Segments (per disk): TDGH-10C for Cured Concrete (10 Segments) TDGH-20C for Cured Concrete (20 Segments) TDGH-20A for Asphalt or Abrasive Surfaces (20 Segments) Removal Rates: Up to five (5) times the material removal rate of Grinding Stones. Life: Up to 15 times the life of Grinding Stones.	Concrete Terrazzo Other Stone Types
Scrubbing Pads (FIG. 19)	Tool Holder Pad (Section 4.7)	Remove mildew, rust, or discoloration from concrete, clean concrete forms, strip scale and rust from steel plate surfaces, remove fins or marks on underlayment materials.	Concrete, Steel

PRE-OPERATION CHECKLIST



Before leaving our factory, every machine is thoroughly tested. Follow our instructions strictly and your machine will give you long service in normal operating conditions.



Before starting the machine, make sure that you read this entire Operations Manual and are familiar with the operation of the machine.

WITH MACHINE COLD AND SETTING LEVEL:

Gasoline Models: Check engine oil. Fill to the full mark on dipstick with 10W30 oil, class MS, SD, SE or better.

Electric Models: Verify that all electrical connections are intact.

1-2 HOUR OPERATION CHECK LIST:



***ALWAYS** place the machine on a level surface with the engine / motor “OFF”, the ignition switch set in the “OFF” position and disconnected from the power source before performing any maintenance. Let the machine cool down!!*

1. Check the engine air cleaner hose clamps. Tighten as required.
2. Tension the drive V-belts. DO NOT over tension!

SCHEDULED MAINTENANCE QUICK REFERENCE



*Before performing any maintenance, **ALWAYS** place the machine on a level surface with the engine / motor “OFF”, the ignition switch set in the “OFF” position and disconnected from the power source!*

SERVICE DAILY:

1. Check engine oil level.
2. Check all guards for damage.
3. Check hoses and clamps for damage or looseness. Tighten or replace as necessary.
4. Check air cleaner. Clean or replace as required.
5. Clean the machine at the end of the day.

SERVICE EVERY 50 HOURS:

1. Replace engine oil and oil filter.
2. Clean engine air fins.
3. Check V-belt tension. DO NOT over tension!
4. Clean Engine fuel bowl.

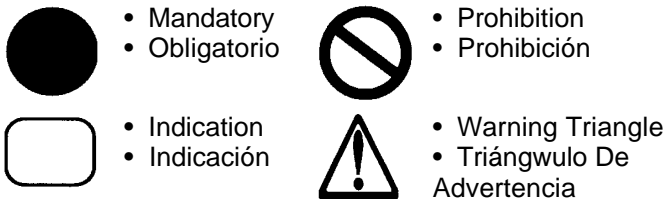

These signs will give advice for your safety

 **Before leaving our factory every machine is thoroughly tested.**

Follow our instructions strictly and your machine will give you long service in normal operating conditions.

1. Features

Use: Surface grinding of concrete or other types of flooring. For repairing horizontal surfaces that have been damaged by the weather, or by improper finishing methods, or that require removal of deteriorated coatings, overlays, or buildups.

Tools:

1) 2 x 2 x 4" (50 x 50 x 100 mm) size, Six (6) per unit. In any of the types shown below:

- a) Grinding Stones [FIG. 14]
- b) Tungsten Carbide Segment Block [FIG. 16].
- c) Tungsten Carbide Impregnated Grinding Block (Not Shown)
- d) Scarifier Blocks (Star, Beam, TC wheels) [FIG. 27 & FIG. 28].
- e) Wire Brushes [FIG. 26].
- f) Diamond Blocks [FIG. 15].

2) Multi-Segmented Diamond Disks: Two (2) disks per unit, 10" (250 mm) diameter, 10 or 20 diamond segments on each disk [FIG. 24 & FIG. 25].

3) Tool Holding Pad, with "hook-and-loop" type of tool attachment, holds the following [FIG. 19]:

- a) Scrubbing Pad [JJ] [FIG. 19]: Two (2) pads per unit, 10" (250 mm) diameter, Nylon mesh Impregnated with Silicon Carbide.

(For information contact your Dealer)

Depth of Cut (Maximum):

See Section 4 (Tool Installation & Application)

Maximum material Size: N/A

Nominal & Operating Weight: See "Specifications".

Dimensions, Grinding Width, Spindle Shaft RPM: See "Saw Dimensions".

 **Before starting up machine make sure you read these instructions and are familiar with the operation of this machine.**

 **The working area must be completely clear, well lit and all safety hazards removed (no water or dangerous objects in the vicinity)**

   **The operator must wear protective clothing appropriate to the work he is doing.**

   **We recommend hearing, respiratory and eye protection.**

 **Any persons not involved in the work, should leave the area.**

 **Only work of flat horizontal areas. Working on steep slopes or hills could cause the operator to lose control of the machine. This could result in injury or death to the operator or other persons in or near the work area!**

2. Assembly

- ❑ When unpacked, this unit is fully assembled, except for installation of the grinding "tools". For tool installation See Section 4 of this document.
- ❑ The dealer or end user must do the installation of optional or accessory items, such as a water tank kit.

3. Check Before Operating

All Models:



- ❑ Take into account the working conditions from a health and safety point of view.
- ❑ For start up refer to the engine, or motor manual.

Electric Models:



The applicable national and local electrical codes and enforcement bodies will be the determining authority on the proper connections and use of this machine. In all cases it the operator/owner's responsibility to ensure that this equipment is in full compliance with these codes.



All machine adjustments & maintenance shall only be done after the machine's power switch has been put in the "OFF" position & the power supply cord completely disconnected.

- Make sure that the extension cord length is properly sized for the motor used on this saw. See the chart in Section 2 of this document.
- Single phase 1-1/2 hp motors are factory wired for 115 volt service and furnished with the correct NEMA configuration *Plug (LL)* [See FIG. 1] on the motor pigtail. See Table 1 below for the proper matching connectors:

Table 1 Electric Motor Plugs & Connectors			
Motor	Wired For Voltage	Motor Pigtail Plug (NEMA No.)	Connector Required (NEMA No.)
1-1/2 HP	115 V	L5-20P	L5-20R
1-1/2 HP	230 V	L6-15P	L6-15R

- For operator convenience, the 1-1/2 hp motor has a *Voltage Change Switch (J)* [See FIG. 5] that allows operation on a 115 VAC or a 230 VAC power source. The *voltage change switch (J)* is mounted on the terminal box of the motor and must be set to either 115, or 230 Volt, to match the voltage supply. Make sure that the *Voltage Change Lock Bolt (TT)* is in position. It will prevent the *Voltage Change Switch* [See FIG. 5] from being accidentally moved into the wrong position.



WARNING: The *Voltage Change Switch (J)* position is never to be changed while the motor is running. Make sure that the *Voltage Change Lock Bolt (TT)* is in position. It will prevent the *Voltage Change Switch* from being accidentally moved into the wrong position.

- Local electrical codes may require changing the plug on the motor to the proper NEMA connector to match the voltage supply.
- The operator must use plug and receptacle connectors on all power cords (machine and extension), designed and approved for the selected motor voltage and equal to or greater than the rated motor full load current.

- The service receptacle, branch circuit conductors, and overcurrent protection shall have an ampere rating equal to or greater than the motor full load current. According to the National Electrical Code if the branch circuit has two or more receptacles, each receptacle has a maximum load ampere rating equal to 80% of the receptacle's rating. When this machine is set up to operate on 115 VAC, the motor has a full load rating of 19 amperes. This means that **when operating this machine on 115VAC, it can only be used on a branch circuit with ONE 20-ampere rated receptacle.** *If the circuit has two or more 20-ampere receptacles, they each have load rating of 16 amperes and cannot be used by this machine.*



WARNING: Always make sure the unit is connected to a properly grounded electrical outlet. Failure to comply with this warning could result in serious bodily injury or death!



WARNING: DO NOT operate on low voltage! Low voltage causes loss of power, motor overheating, and possibly motor winding burnout. Voltage should be checked at the motor while it is operating.

- The extension cord(s) used must have a voltage rating greater than the selected voltage (115 or 230) and be sized for the rated motor full load amps (as marked on motor specification plate).
- Good motor performance depends on proper voltage. Extension cords that are too long and / or too small reduce the voltage to a motor under load. Operating below this minimum voltage will cause an increase in motor current resulting in slow startup, and overheating in the motor and controls. Sustained operation under these conditions will result in permanent damage to the motor and controls.
- Long extension cords will probably have to be oversized to minimize the voltage drop to the machine. The size of the extension cord is dependent on the total conductor length (all extension cords) & the quality of the power source. The power cord size shall be capable of supplying **a minimum of 90% of the motor nameplate voltage at the motor**, when the motor is running rated full load.
- Make sure that the extension cord length is properly sized for the motor used on this machine. Use extension cords **NO SMALLER** than the sizes indicated in Table 2 below:

Table 2 EXTENSION CORD SIZE (Minimum)						
MOTOR HP	50 ft Long		75 ft Long		100 ft Long	
	120 V	230 V	120 V	230 V	120 V	230 V
1-1/2	# 12	# 14	# 10	# 14	# 8	# 14

- The branch circuit must have overcurrent protection in the form of a circuit breaker or fuses. The purpose of the overcurrent protection is to limit the current in the branch circuit conductors and connections to an amount equal to or less than their ratings. This is to prevent overheating that can lead to damage or a fire. The overcurrent protection will not protect the operator from an electrical shock due to improper grounding practice, frayed or cracked extension cords, or other defective electrical components. This exposure to electrical shock increases greatly whenever the equipment is used around water or other conductive fluids. The operator will be provided with electrical shock protection whenever the machine is connected to a circuit that has a Ground Fault Circuit Breaker. The Ground Fault Circuit Breaker will open the circuit whenever it senses a fault current, greater than a few milliamps, in the ground path. If a receptacle with a *Ground Fault Circuit Breaker* is not available, a *Portable Ground Fault Circuit Interrupter [MM]* [See FIG. 7] can be used at the branch receptacle to provide the same level of protection.

Gasoline Model:



- Engine Fuel: Check the engine operation manual. Unleaded gasoline is recommended.
- Engine Oil: Put the AXLE in the OPERATION POSITION [F] [See FIG. 11] so that the engine is in a horizontal position, then, check that the engine oil level is correct. Check the oil level frequently to ensure that the level never falls below that specified in the engine operation manual. If the oil level is low, add SAE 10W30, service classification SF or SG oil (for normal conditions) as recommended in the engine operation manual. DO NOT overfill engine with oil!
- Before starting the engine verify that the Throttle Lever [L] is between the START [N] and STOP [M] position. This will allow the engine to be started while the clutch is disengaged. NOTE: The engine clutch will engage at 1800 RPM, and the Accessory Disks [P] will begin to rotate.
- Before starting the engine, verify that the engine does NOT exceed 20 degrees angle of inclination when the unit is in operation.



WARNING: Run the machine only if the grinding heads are on the ground. Raising the front of the machine with the engine or motor running could cause injury or death to bystanders or the operator. Also, engine inclination angles greater than 20 degrees could cause severe engine damage and void your engine warranty!

4. Tool Installation

TOOL INSTALLATION:

- 1) **Rear Axle Position (See FIG. 11):** Make sure the Axle is in the *Transport Position [E]*. Using TABLE 3 (below) install the *Axle Stop Bolts [G]* in the proper position for the tool being mounted. The *Axle Stop Bolts [G]* are factory installed in the F2 position.



Table 3 shows the tools specified by our company. Tools from other manufactures may fit onto this machine. Measure "Tool Height" to determine the proper axle position (See TABLE 4) for these tools.

TABLE 3 Rear Axle Positions (See FIG. 11)		
Tool	Tool Height	Axle Position
Grinding Stones	2.0" (51 mm)	F2
Tungsten Carbide Block	2.1" (53 mm)	F2
Diamond Segment Block	2.1" (53 mm)	F2
Star wheels	2.25" (57 mm)	F2
Beam Cutter Wheels	2.25" (57 mm)	F2
TC Wheels	2.15" (54 mm)	F2
Diamond Disks	2" (51 mm)	F2 or E2
Scrubbing Pad (with Adapter)	1.7" (43.2mm)	F3

If the tool to be installed is not listed in TABLE 3:

- a) Measure the "Tool Height".

TABLE 4 Tool Height for Axle Positions (See FIG. 1)	
Axle Position	Minimum Tool Height
F1	2.44" (62 mm)
F2	2.00" (50.8 mm)
F3	1.69" (42.9 mm)
F4	1.00" (25.4 mm)

- b) Using TABLE 4, find a "Minimum Tool Height" equal to, or greater than, the measured tool height.
 - c) Referencing FIG. 11, install and tighten the *Axle Stop Bolts [G]* in the Axle Position (F1, F2, etc) determined from step b) above.
- 2) **Raise Front Shield (A):** Loosen the three (3) *Capscrews [B]* that hold the *Front Shield [A]* in position. Raise the *Front Shield* to its upper position, then tighten the *Capscrews [B]* to hold it in place.
 - 3) **Tilt Machine Backwards:** When on a flat surface, tilt the machine backward until the *Handles [FF]* rest on the ground. If you are not sure the machine will stay in this position, add a weight or other device to the handle to secure them to the ground.



WARNING: Make sure the machine is stable when the front end is raised into the air! Secure the machine in this position if you are not sure about its stability. Secure machine BEFORE starting attachment of the tools to the accessory disks!

- 4) **Tool Installation on Accessory Disk [P]:**
See FIG. 14, FIG. 15, FIG. 16, FIG. 26, FIG. 27
- a) Place the Tool [GG 1] so that it rests against the back and outside of the tool holding area of the Accessory Disk [P]. Place the Wooden Wedge [U] between to the inside edge of the Tool [GG 1] and the Accessory Disk [P].
- b) Firmly tap the Wooden Wedge [U] into position using a hammer. Tap the Wooden Wedge [U] until the Tool [GG 1] is securely fastened into the Accessory Disk [P]. Rotate the Accessory Disk [P] and repeat this procedure for all six (6) tools.
- ⇒ **Note:** Soaking the Wooden Wedges (U) in water before assembly could increase the gripping power of the wedges and prolong the time that the tool stays fixed to the machine.
- c) Gently lower the front of the machine until the tools touch the ground.
- d) Pivot the axle so that it is in the OPERATION POSITION [F] [FIG. 2].
- e) Lower the FRONT SHIELD [A] from its upper position. Loosen the three (3) CAPSCREWS [B] and lower the shield so that it is only 3/8-1/2" (10-12 mm) from the ground.

4.1	Grinding Stones [See FIG. 14]
------------	--------------------------------------

For Light Grinding of Rough Areas. Material is Silicon Carbide, the "grit" size is designated by number (similar to most abrasive products). The larger the number, the finer the grain structure, the smoother the surface finish achieved, and the longer the grinding stone life. Some of the available "Grit" Sizes are shown below:

- a) **TC-10 Coarse Grit:** Maximum material removal, General grinding & removal of trowel marks, high spots, and rough sections of concrete. Life 4-10 hours.
- b) **TC-24 Medium Grit:** Lower material removal rate, Finer finish grinding of concrete, and rough grinding of Terrazzo and other stone type. Life 6 – 10 hours.
- c) **TC-80 Fine Grit:** Still lower material removal rates. For polishing of concrete and medium grinding on Terrazzo and stone type floors. Life 8 – 20 hours.

4.2	Diamond Segment Blocks [FIG. 15]
------------	---

Remove High Spots, Trowel & Rain Marks, Paints, Sealers & Mastics, Uneven Joints, Aggressive Grinding of Large Rough Areas, Removal of epoxies, paints and many thin film coatings, or Final Preparation for new coating.

Available In Different "Grit" Sizes:
GB-10 General Purpose
GB-20 Abrasive Materials
GB-30 Epoxy & Non-Abrasive Materials.

Removal Rates: Up to five (5) times the material removal rate of Coarse Grinding Stones.

Life: Up to 15 times the life of Grinding Stones.

4.3	Tungsten Carbide Blocks [See FIG. 16]
------------	--

Comes in a complete kit (P/N 177823) [FIG. 17] that includes six steel blocks, six tungsten carbide cutters, hardware and tools, and six wooden wedges.

A replacement cutter kit (P/N 177824) [FIG. 18] is also available. It includes six tungsten carbide cutters, six wooden wedges, and all hardware and tools to mount the cutters.

Removes material with a cutting or shaving action and works best at removal of thick coatings such as paint buildups. Not recommended for thin (< 5 mil) films of materials. Not recommended for adhesives, rubber deposits and mastics that have a tendency to extrude or smear rather than "shear" loose from the floor surface. A water or a water / sand mixture can be added on the surface to reduce this problem. Adding additional external weight to the machine can also improve the material removal rate.

Each tool contains one tungsten carbide insert. Each insert has eight (8) cutting edges. When one of the edges becomes dull, loosen the attaching bolt using the hex wrench provided, and rotate the insert 90 degrees. When these four (4) cutting edges are dull, simply remove the insert and flip it over to expose four (4) new cutting edges.

4.4	Scarifier Wheels [FIG. 27, FIG. 28]
------------	--

Remove Fiberglass, Ice, Oil-Dry, Foam-Fill Packing Material & Floor Buildups. Lightly Textures Surface.

Available in three (3) configurations:

- a) **Star Wheel:** Hardened Carbon Steel material. For removal of thin coatings and encrusted accumulations of material. Cleaning concrete of asphalt surfaces. Removing thick build-up of grease, paint, and some resins. Light scarifying before application of coatings or sealer. Creates a swept, or "broomed" type of finish.
- b) **Beam Wheel:** Medium duty, for concrete and asphalt scarifying. De-scaling steel decks. Removing thick material build-up of grease, paint, and some resins. Twice

the life, near the same cost as a star wheel.

- c) **Tungsten Carbide Wheel:** Heavy Duty asphalt or concrete scarifying, or de-scaling of steel decks. 10 times the life of a star wheel.

Assembly: When new cutters are installed, be sure to “stagger” the washers in order in avoid any “blind spots” in the cutter path (On any one cutter block put the first washer on the opposite end of each stack of cutters). Also make sure that the wheels can rotate freely when the attaching Capscrews are tightened.

Bushings: Be sure to inspect the cutter bushings on a regular basis. Worn bushing can cause the Scarifier Wheels to break and be thrown against the inside of the machine frame.

4.5	Wire Brushes [See FIG. 26]
------------	-----------------------------------

For Light Scarifying and cleaning. Flat wires are available in many sizes and configurations. They should be rotated end-for-end in the *Accessory Disk [P]* every hour to avoid the wire taking a “set” (wire will bend in one direction). External weight added to machine will NOT normally increase production rates, but only accelerate the wire brush wear rates.

4.6	Multi-Segmented Diamond Disks [Q] [See FIG. 24 & FIG. 25]
------------	---

- a) Temporary removal of the *Front Shield (A)* may be required to complete this installation.
- b) Attach the *Multi-Segmented Diamond Disks (Q)* to the *Adapter Plate (R)* using the four (4) *Flat Head Screws (S1)* and *Thin Locknuts (S2)* provided in the *Adapter Plate Kit (Kit Part Number 177861)*. Tighten the *Screws (S1)* securely. Repeat this procedure for the other *Adapter Plate (R)*.
- c) Attach the *Diamond Disk / Adapter Plate Assembly* to the machine using the three (3) *Capscrews (T1)*, *Lockwashers (T2)*, and *Washers (T3)* provided in the *Adapter Plate Kit*. Tighten the *Capscrews (T1)* securely. Repeat this procedure for the other assembly.
- d) Gently lower the front of the machine until the tools touch the ground.
- e) Pivot the axle so that it is in the *Operation Position [F]* [See FIG. 11].
- f) Lower the *Front Shield [A]* from its upper position. Loosen the three (3) capscrews and lower the shield so that it is only 3/8-1/2” (10-12 mm) from the ground.

Notes: If machine starts to vibrate and shake try removing external weight from the machine. If the vibration continues, move the axle into the “E2” position [See FIG. 11]. This position is normally a

“transport” position, but for the diamond disks it removes most of the weight from the front of the machine and allows the disks to glide over the surface rather than dig into the surface.

4.7	Tool Holding Pad (HH) Installation [See FIG. 19, FIG. 20, FIG. 21, FIG. 22, FIG. 23]
------------	--

This machine will allow the use of Scrubbing Pads [JJ] that are available from another manufacture.

- a) Position the triangular area of the *Tool Holding Pad [HH]* [See FIG. 21] so that it mates with the triangular area on the *Accessory Disk [P]*.
- b) Use the 1/2-20UNF x 1-1/4” Long Capscrew [SS1] and Lockwasher [SS2] to attach the Tool Holding Pad to the Accessory Disk. Tighten the capscrew securely, using the 3/4” (19 mm) End of the Wrench [V] [Shown in FIG.8].
- c) Repeat this procedure on the other *Accessory Disk [P]*.
- d) Install the Scrubbing Pads [JJ], two (2) per machine. Gently press the tool onto the hook and loop fastening system until it is secure.
- e) Gently lower the front of the machine until the tools touch the ground.
- f) Pivot the axle so that it is in the *Operation Position [F]* [See FIG. 11].
- g) Lower the *Front Shield [A]* from its upper position. Loosen the three (3) capscrews [See FIG. 2 & FIG. 3] and lower the shield so that it is only 3/8-1/2” (10-12 mm) from the ground, then re-tighten the three (3) capscrews.

5. Operating Instructions

All Models:

- Configure the unit with the proper tool for the job. See Section 4 of this document for tool installation.

Start / Stop of Electric Models:



WARNING: Make sure the *Voltage Change Switch (J)* [See FIG. 5], is set to either 115, or 230 Volt, to match the voltage supply. The *Voltage Change Switch (J)* position is never to be changed while the motor is running.

Make sure that the *Voltage Change Lock Bolt (TT)* is in position. It will prevent the Voltage Change Switch from being accidentally moved into the wrong position.

Local electrical codes may require changing the Plug (LL) [See FIG. 1] on the motor to the proper NEMA connector to match the voltage supply.



WARNING: Always make sure the unit is connected to a properly grounded electrical outlet. Failure to comply with this warning could result in serious bodily injury or death!

- 1) Before starting the electric motor (if set for 115 Volt Operation) push down on the handles just enough to release pressure from the grinding disks. Start the electric motor by turning the *Power Switch [H]* (See FIG. 6) to the **ON** position.



WARNING: DO NOT push down on the handles enough to lift the grinding disks from the ground.

- 2) Once the motor has reached full speed, reduce the downward pressure applied to the handles and let the weight of the machine rest on the ground.
- 3) Hold the handles firmly and gently guide the machine over the work area.



WARNING: Keep hands clear of rotating tools during operation. READ ALL SAFETY WARNINGS before operating this machine.

4) STOPPING THE UNIT (Electric Models):



Stop the unit by turning the *POWER SWITCH [H]* to the **OFF** position (See FIG. 6). Wait for all tool movement to stop before transporting the machine.

Start / Stop of Gasoline Models:

[FIG. 9 & FIG. 10]

- 1) Start the engine by using the procedure in the engine operation manual.
- 2) Push *Throttle Lever [L]* up to, but not past, the **START** position (Position "2") [FIG. 9 & FIG. 10]. In this position the engine clutch will be disengaged when the engine starts, so the accessory disks will not rotate.
- 3) Starting a cold engine: Pull the *Choke Lever [O]* upward. Pull the engine starter rope until the engine starts, then push *Choke Lever [O]* downward.
Starting a warm engine: Same as above, except that Choke may not be needed. (*Choke Lever [O]* may need to be pushed downward into "No Choke" Position).
- 4) Move the Throttle Lever [L] past the START position (Position 2) so that the engine clutch engages and the accessory disks begin to rotate.
- 5) Hold the handles firmly and gently guide the machine over the work area. Note: For rough surfaces the engine speed (engine RPM's) should remain as low as possible. As soon as the surface begins to become smooth the engine speed can be increased, but running the engine at full throttle is normally not required.



WARNING: Keep hands clear of rotating tools during operation. READ ALL SAFETY WARNINGS before operating this machine.

6) STOPPING THE UNIT (Gasoline Models):



Normal or Emergency Stop: Pull the Engine Throttle into the STOP position [Position M] [See FIG. 9, and FIG. 10]. Wait for all tool movement to stop before transporting the machine.

6. Incidents During Operation



WARNING: Before inspecting or performing any maintenance, ALWAYS locate the machine on a level surface with the engine / motor OFF, and the start switch in the OFF position, and the power source disconnected.

- 1) If the engine or motor stops during operation, check the following:

Electric Model:

- a) Interruption to electrical connection: Check all electrical connections.
- b) Manual Overload switch has been tripped: Single phase, 60 Hertz motors are equipped with a manual *overload Reset Button [K]* [FIG. 4]. If the motor stops because of an electrical overload and the *overload Reset Button [K]* trips, turn the motor *Power Switch (H)* to the OFF position [FIG. 6]. Allow the motor to cool for 5 to 10 minutes, then push the *Reset Button [K]*. A "click" sound indicates that the motor is reset and ready for operation. Restart the motor by reconnecting the machine to the power source, and then turn the *Power Switch [H]* to the ON position.

Gasoline Model:

- a) Out of fuel: Check fuel level.
- b) Low Oil Level: This unit is equipped with a shut down system that stops the engine if a low oil level is encountered. Check the engine oil level with the rear axle in the *Operation Position [F]*.

All Models:

- a) Excessively fast grinding could stall the engine or motor.
- 2) Engine or Motor runs, but Accessory Disks don't rotate. Check the following:

All Models:

- a) Check that the drive belt tension is adequate.

Gasoline Models:

- a) Engine Clutch not properly working. Repair or replace as required.

7. Maintenance



WARNING: Before performing any maintenance, ALWAYS locate the machine on a level surface with the engine / motor OFF, and the start switch in the OFF position, and the power source disconnected.

Check Daily:

- 1) All Models:
 - a) At the end of each day clean the machine to remove sludge buildup.
- 2) Gasoline Model:
 - a) Check engine air cleaner daily! If cutting dry check engine air cleaner every four hours! Clean or replace air cleaner element as recommended by the engine manufacturer.
 - b) Check engine oil daily. Change engine oil after every 50 hours of operation. Engine Oil capacity is See engine operation manual for proper care and maintenance.

Every 50 Hours:

- 1) All Models:
 - a) **Lubrication Points:**



Lubricate every 50 hours using only a Premium Lithium 12 based grease conforming to NLG1 GRADE #2 consistency.

- 1) **Spindle Bearings:** Six places total, three Bearings [RR 1] on top of the gearbox [FIG. 29] and three below the gearbox (Not Shown).
- 2) **Rear Wheels:** Two places [FIG. 30].

- 2) Gasoline Model:



Change Engine Oil: Change engine oil after every 50 hours of operation.

Engine Oil Type
Under normal operating conditions use SAE 10W30 API service classification SF or SG. See engine operation manual for other recommended oil types.

Engine Oil Capacity (Honda GXV340)	
1.16 U.S. Quarts	1.1 Liters

a) Engine Oil Change Procedure:

1. Drain the oil while the engine is still warm to assure rapid and complete oil drain. Pivot the Rear Axle To The *Operation Position [F]*. Place a bucket under the *Oil Drain Hose [WW]*, [FIG. 12, FIG. 13] to catch the used oil. Remove the oil drain plug on the end of the *Oil Drain Hose [WW]* and wait for all of the used oil to be drained for the engine.
2. Re-install and securely tighten the plug in the end of the *Oil Drain Hose [WW]*.

3. Re-fill engine with the recommended oil type. See the engine operation manual for the oil fill location and proper oil level. Note that the required oil capacity will be slightly larger because of the volume of oil contained in the *Oil Drain Hose [WW]*.
4. Check the oil level. If the proper oil level is indicated, re-install the oil fill cap.
5. Dispose of the used oil in a proper container and in a manner that is compatible with the environment.

When Required:

- 1) All Models:
 - a) **Lubrication:**
Gearbox Grease Port [RR 3] [See FIG. 29]: Used to lubricate the transmission gears, if required. These gears are factory lubricated with 24 ounces (.68 kg) of Lubriplate (Brand) 630-2 or equal, and should not require any lubrication until service work to the gears is required (at 500 – 1000 hours). Lubricate as required with Lubriplate (Brand) 630-2 or equal. To inspect the inside of the gearbox, remove the two Capscrews that attach the Gearbox Grease Port Cover [RR 3] and remove the cover. A 1.00" (25 mm) hole in the gearbox allows visual inspection of the condition and quantity of the grease and the gears.

Note: Early models have one removable Capscrew that exposes a .50" (12 mm) diameter inspection hole.

- b) **Replace Accessory Disk Isolators:** Each of the Accessory Disks [P] have six (6) rubber isolators (See Parts List – Gearbox Assembly) that constantly flex and move as the machine operates. Over time the isolators can deteriorate and wear out. Check to see if they are damaged or deteriorated, if so, replace immediately. All twelve (12) isolators should be replaced as a set.
- c) **V-Belt Inspection:** Check to see that the V-belts are not frayed or worn. If they are, replace immediately.

8. V-Belt Tension

All Models:

Check V-Belt tension when unit is new and never set belt tension beyond this point.

The machine is equipped with high tension V-Belts. The belts are properly tensioned at the factory, but after a few hours of operation they will stretch and become loose.

- a) Tensioning Blade Shaft V-Belts:
 - 1) Loosen the four (4) *Motor Base Capscrews [ZZ]* [FIG. 3] that attach the motor or engine platform to the frame.
 - 2) Loosen the Jam Nut [YY] [FIG. 32] until it is not preventing the *Belt Tensioning Drawbolt [UU]* from rotating.
 - 3) Tighten the *Belt Tensioning Drawbolt [UU]* [FIG. 32] until the V-belts are tightened to the original factory tension.
 - 4) Tighten the Jam Nut [YY] against the Motor / Engine Platform until the Belt Tensioning Drawbolt [UU] is locked in position.
 - 5) Re-tighten the four *Capscrews [ZZ]* that attach the motor / engine platform [FIG. 3].

9. Important Advise

- When storing for an extended period of time, use a wire brush to remove hard, caked sludge. Clean and thoroughly lubricate moving parts - so the next job the machine is ready for operation.
- Drive belts must be tight. When the belts are loose, power is lost. Replace worn belts without delay!
- Replace noisy bearings immediately! Worn bearings will quickly destroy the tools.

10. Accessories

The following accessories and kits are available for this machine. See the Parts List section of this document for the part number. For additional information contact your local dealer or call our Toll free Customer Service Telephone number shown on the front cover:

- **Weight Kit** [FIG. 12, FIG. 13]:
 - a) ***Items included in kit:***
 - 1) *Weight Tray [Z]* and *Weight Tray Attaching Hardware [AA]*.
 - 2) Removable Weight Box [BB] and *Safety Bolts [CC]*.
 - 3) Nine (9) Steel *Weight Bars [DD]* totaling 58 Lbs. (26 kg), and *Weight Bar Attaching Hardware [EE]*. Note: Can hold an additional Nine (9) Weight bars (Sold Separately) for a Total Maximum Weight of 117 Lbs. (53 kg).
 - b) ***Installation of Kit (Also See Parts List):***
 - 1) Remove the four (4) existing Capscrews installed in the weight tray mounting holes (used to plug the holes in the gearbox).

- 2) Mount the *Weight Tray [Z]* using the *Weight Tray Attaching Hardware [AA]* supplied in the kit (Four Capscrews, Lockwashers, and Washers).
- 3) Install the *Weight Bars [DD]* into the *Weight Box [BB]*. Use the *Weight Bar Attaching Hardware [EE]* to install the Weight Bars inside the Weight Box. Install the Capscrews so that the heads are to the front of the weight box (outside of machine). Place the smaller washers between the larger washers to form a “notch” that will hold the box assembly in place on the machine. Tighten the Locknuts so that the *Weight Bars [DD]* are held securely in the *Weight Box [BB]*.
- 4) Lift the assembled *Weight Box [BB]* onto the *Weight Tray [Z]* (installed on the machine). Align the Washers so that they fit into the slots in the back of the Weight Tray [Z]. Lower the Weight Box [BB] onto the Weight Tray [Z].
- 5) Use the Hold-Down Bolts [CC] as a method to hold the Weight Box [BB] securely to the machine. If the Hold-Down Bolts [CC] are not used the Weight Box can be lifted off of the machine, but this is not recommended if the machine is to be used of a rough surface, or if the machine is to be lifted into the air for any reason.



WARNING: DO NOT lift the machine into the air unless the Weight Box [BB] is securely fastened to the machine using the Hold-Down Bolts [CC]. The recommended method is to remove the Weight Box [BB] BEFORE lifting the machine. The machine will then remain horizontal when lifted, using the lifting point.

- **Water Tank Kit** [FIG. 1, FIG. 11, FIG. 31]:
 - a) ***Items included in kit (See Diagram 4):***
 - 1) *Water Tank Assembly [QQ1]*. Includes Lid, Water Valve [QQ2], and Hose.
 - 2) *Water Tank Bracket [QQ 3]* and *Attaching Hardware*.
 - 3) *Nozzle Bracket Assembly (Not Shown)*, and *Attaching Hardware*.
 - 4) *Hose Clamps [QQ 4]* and *Attaching Hardware*.
 - b) ***Installation of kit (Also See Parts List):***
 - 1) *Water Tank Assembly [QQ1]* comes pre-assembled. Place *Water Tank Assembly [QQ1]* in frame as shown in FIG. 1. Leave the end of the hose free.

- 2) Mount the Water Tank Bracket [QQ 3] INSIDE of the handle supports (frame) as shown in FIG. 1, FIG 2 and FIG. 3. Using two (2) each of the M8 Capscrews, Lockwashers, Washers included in the kit, secure the *Water Tank Bracket [QQ 3]* in position.
- 3) See FIG. 31. At the back of the machine, to the right side of the *Dust Port [XX]* find the *Hose Port Cover [AAA]*. Using the small end of the *Wrench (V)* loosen the two (2) M8 Capscrews that hold this cover in position, then rotate it counter-clockwise until the Hose Port is exposed. Re-tighten the M8 Capscrews until the *Hose Port Cover* is secured in its lowered position.
- 4) Move the Axle into the *Transport Position [E]* [FIG. 11] and tilt the machine backwards until the handles are resting on the ground.
- 5) Under the front of the machine, and in front of the *Accessory Disks (P)*, find and remove the two M8 Capscrews, Lockwashers, and Washers that match the pattern in the *Nozzle Bracket Assembly (Not Shown)*. Remove these Capscrews, Lockwashers, and Washers from the machine. This hardware was used only to plug holes in the gearbox.
- 6) Using the two (2) *M8 Capscrews, Lockwashers, and Washers* supplied in the kit, mount *the Nozzle Bracket Assembly with the hose barb fitting toward the rear of the machine*.
- 7) Take the free end of the *Water Tank Hose* and slide a *Hose Clamp [QQ 4]* loosely over the hose. Route the hose through the side of the machine [See FIG. 1 and the opened *Dust Port Cover [FIG. 31]*. Attach the hose to the Hose Barb fitting on *the Nozzle Bracket Assembly*.
- 8) Slide the Hose Clamp down the hose until it is on the Hose Barb fitting at the Nozzle Bracket. Tighten the M6 Capscrew, and Lockwasher that hold the *Hose Clamp [QQ 4]*.
- 9) Install two (2) more Hose Clamps [QQ 4] along the frame [See FIG. 1].
- 10) Make sure the Water Valve (QQ 1) is closed before adding any water to the water tank.



WARNING: DO NOT lift the machine into the air if the Water Tank is filled with water. This added weight will cause the balance point to be shifted so that the machine will not lift in a horizontal position.

11. Repairs

We carry out all repairs in the shortest possible time and at the most economical prices. See front cover for our address and telephone numbers.

12. Spare Parts

For a quick supply of spare parts it is essential to quote the data shown on the *Serial Number Plate [VV]* [See FIG. 13] fixed to the machine. Make note of this information & the purchase date below, and on the front cover of this document for quick reference:

Model:	Serial No:	Date:
_____	_____	_____

PARTS LIST

LISTA DE PIEZAS

Parts List Callout Designation:

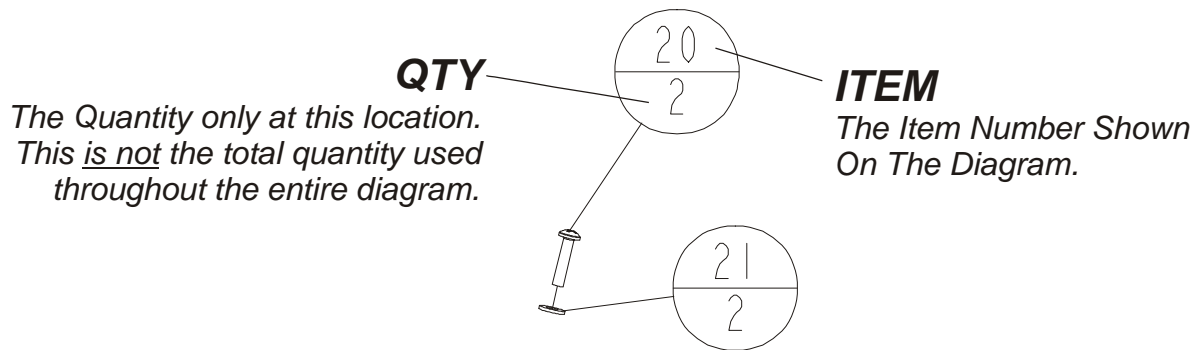

Diagram 1 – Final Assembly Group, 1.5 hp Electric

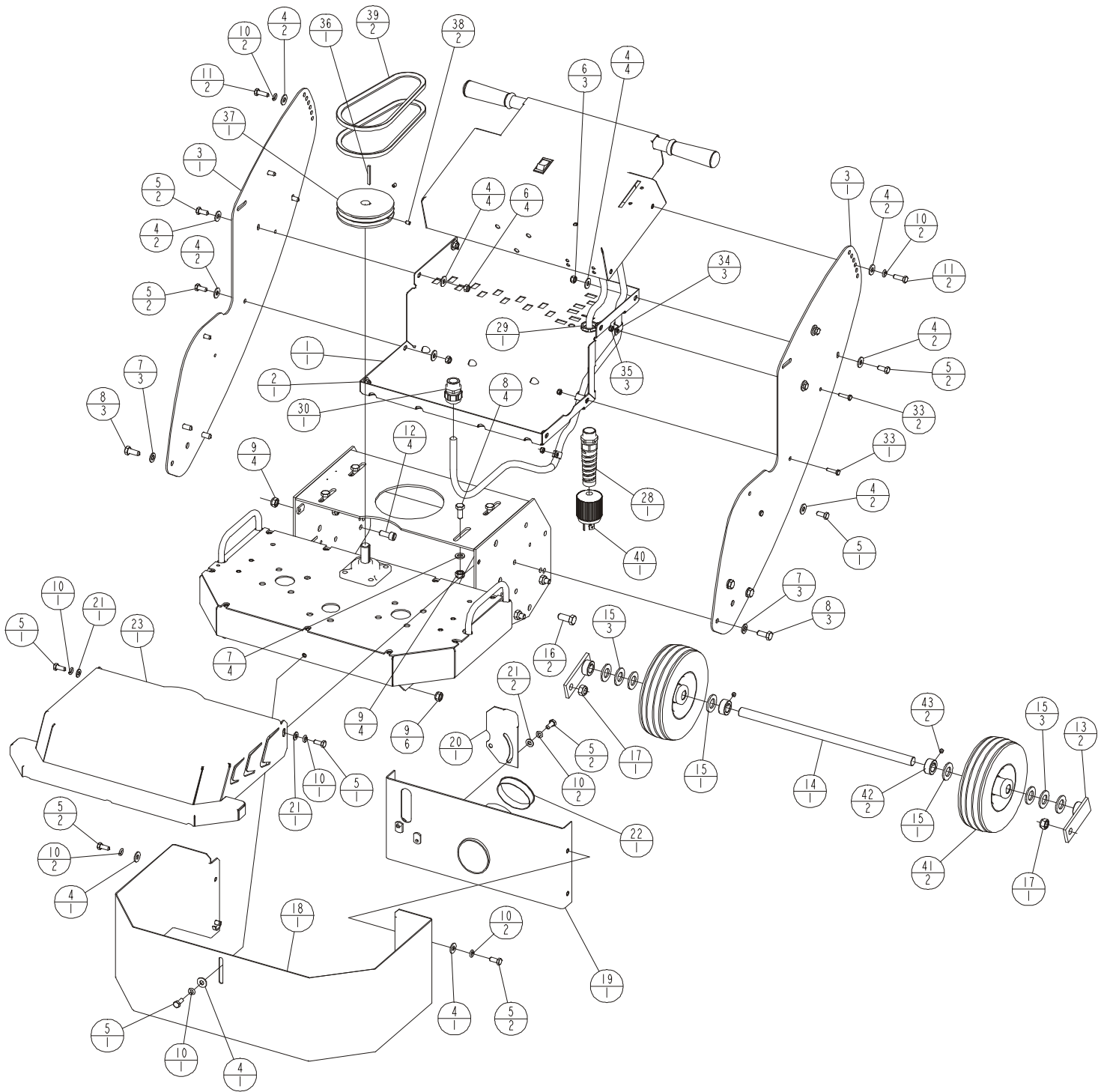

Diagram 1 Parts List – Final Assembly Group, 1-1/2 hp Electric

ITEM	P/N	DESCRIPTION	QTY
1	-----	Final Assembly - Electric	1
2	177783	Water Tank Support	1
3	177780	Support, Handle	2
4	020742	Washer, Flat .313 Dia	23
5	197227	Capscrew, Hex Hd M8 x 1.25 x 20mm	16
6	139738	Locknut, Fiber M8 x 1.25	7
7	173014	Washer, Flat M10	10
8	139749	Capscrew, Hex Hd M10 x 1.50 x 25mm	10
9	139748	Locknut, Fiber M10 x 1.50	14
10	020785	Lockwasher, Split .312 Dia	13
11	167478	Capscrew, Hex Hd M8 x 1.25 x 25mm	4
12	164954	Capscrew, Soc Hd M10 x 1.50 x 25mm	4
13	177752	Axle Pivot Bar Weldment	2
14	177754	Axle, 3/4 Dia x 16.68 Lg	1
15	020768	Washer, Flat .75 Dia SAE	8
16	139741	Capscrew, Hex Hd M12 x 1.75 x 30mm	2
17	139742	Locknut, Fiber M12 x 1.75	2
18	177804	Dust Shield Weldment	1
19	177807	Dust Port Weldment	1
20	177817	Dust Shield Cover	1
21	020763	Washer, Flat .312 SAE	4
22	177772	Cap, Dust Port	1
23	177801	Gearbox Cover Weldment	1
24	187051	Decal, Dual Trac	3 (Not Shown)
25	052130	Decal, Target	2 (Not Shown)
26	177857	Decal, Oper. Instr.	1 (Not Shown)
27	176223	Decal, Warning, Guards In Place	2 (Not Shown)
28	177745	Strain Relief, 3/4 NPT (w/flex extender)	1
29	177746	Nylon Locknut, 3/4 NPT	1
30	182024	Strain Relief, 3/4 NPT	1
31	046422	Wire Connector, #10 x 12-10GA , Ring Terminal	1
32	170058	Electrical Nut, Yellow	2
33	139740	Capscrew, Hex Hd M6 x 1.0 x 25mm	3
34	166673	Clamp, Vinyl Coated 1/4 Hole x 5/8 ID	3
35	139745	Locknut, Fiber M6 x 1.0	3
36	020080	Key, Square .188 x 1.75 Lg	1
37	177955	Pulley w/SS, 2G3V4.75 .75 Bore (Incl. Item 38)	1
38	020541	Screw, Set Soc Cup Pt .250-20UNC x .375	2
39	177749	Belt, 3VX250 (Electric Motor)	2
40	030103	Plug, Motor Pigtail, L5-20P P-S	1
41	177768	Wheel, 8 x 2.50	2
42	041160	Lock Collar, .750 ID	2
43	020551	Screw, Set Soc Cup Pt .312-18UNC x .25	2

Parts List Callout Designation:

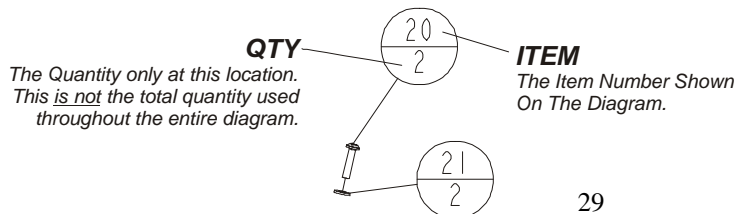

Diagram 2 – Final Assembly Group, 11 hp Honda Gas

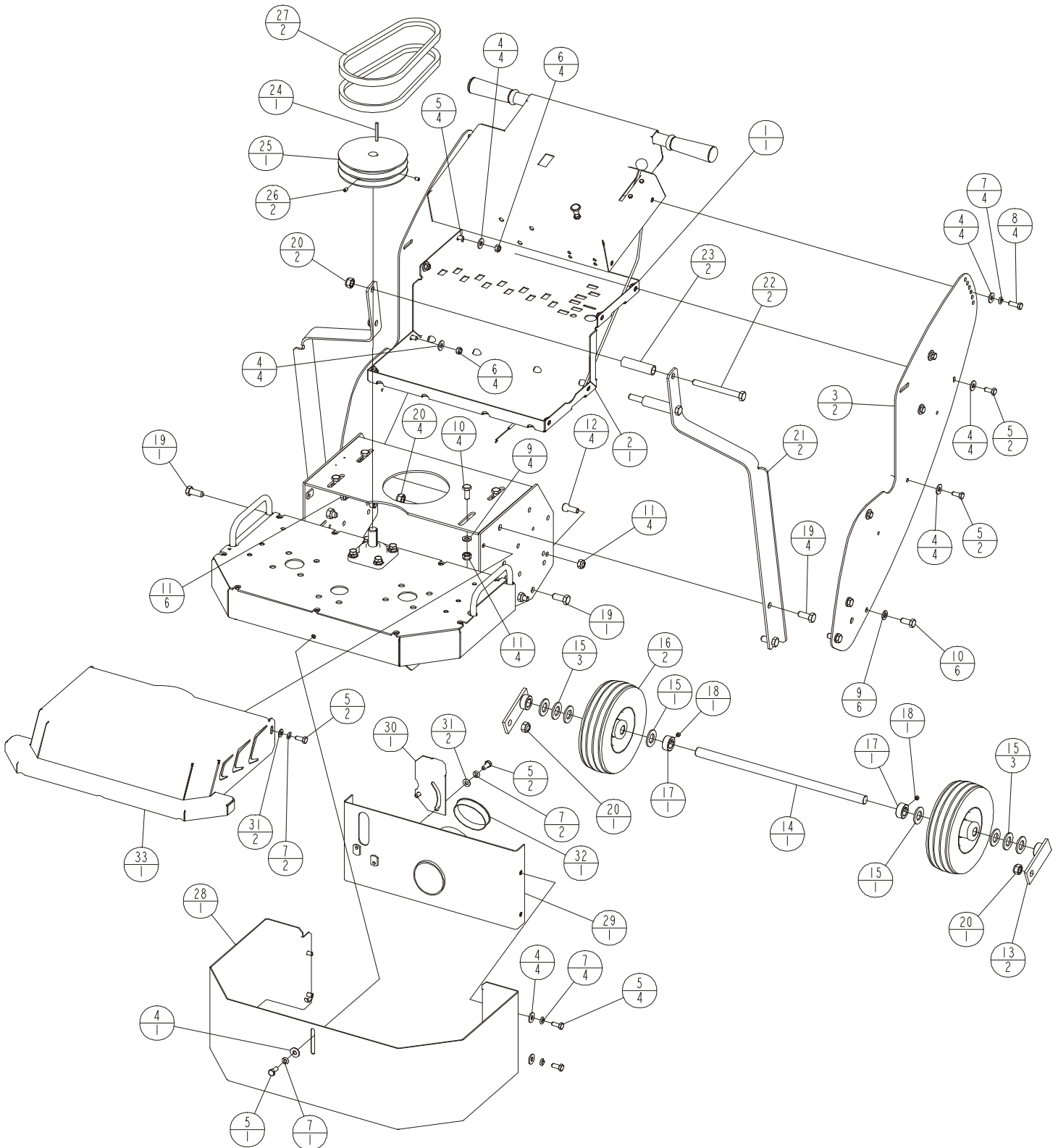

Diagram 2 Parts List – Final Assembly Group, 11 hp Honda Gas

ITEM	P/N	DESCRIPTION	QTY
1	-----	Final Assembly, Gas	1
2	177783	Water Tank Support	1
3	177780	Support, Handle	2
4	020742	Washer, Flat .313 Dia	25
5	197227	Capscrew, Hex Hd M8 x 1.25 x 20mm	17
6	139738	Locknut, Fiber M8 x 1.25	8
7	020785	Lockwasher, Split .312 Dia	13
8	167478	Capscrew, Hex Hd M8 x 1.25 x 25mm	4
9	173014	Washer, Flat M10	10
10	139749	Capscrew, Hex Hd M10 x 1.50 x 25mm	10
11	139748	Locknut, Fiber M10 x 1.50	14
12	164954	Capscrew, Soc Hd M10 x 1.50 x 25mm	4
13	177752	Axle Pivot Bar Weldment	2
14	177754	Axle, 3/4 Dia x 16.68 Lg	1
15	020768	Washer, Flat .75 Dia SAE	8
16	177768	Wheel, 8 x 2.50	2
17	041160	Lock Collar, .750 ID	2
18	020551	Screw, Set Soc Cup Pt .312-18UNC x .25	2
19	139741	Capscrew, Hex Hd M12 x 1.75 x 30mm	6
20	139742	Locknut, Fiber M12 x 1.75	8
21	177946	Lift Bail	2
22	167661	Capscrew, Hex Hd M12 x 1.75 x 120mm	2
23	166194	Spacer, Lift Frame	2
24	020080	Key, Square .188 x 1.75 Lg	1
25	177956	Pulley w/SS,2GB5.95-.75 Bore(Incl. Itm 26)	1
26	020541	Screw, Set Soc Cup Pt .250-20UNC x .375	2
27	177798	Belt, B-26 (Gas Model)	2
28	177804	Dust Shield Weldment	1
29	177807	Dust Port Weldment	1
30	177817	Dust Shield Cover	1
31	020763	Washer, Flat .312 SAE	4
32	177772	Cap, Dust Port	1
33	177801	Gearbox Cover Weldment	1

Items Not Shown On Diagram (For Pictures See “Decal Description” Page Of This Document):

34	187051	Decal, Dual Trac	3
35	052130	Decal, Target	2
36	177857	Decal, Oper. Instr.	1
37	176223	Decal, Warning, Guards In Place	2

Parts List Callout Designation:

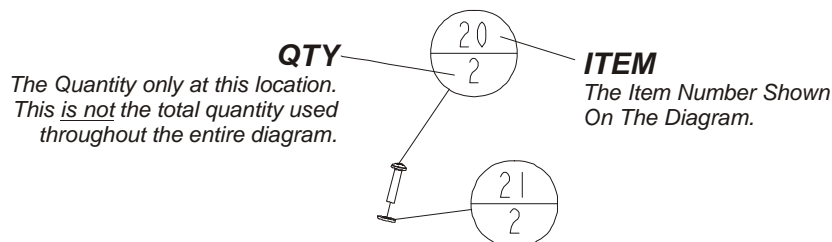

Diagram 3 – Handle Group, 1.5 hp Electric

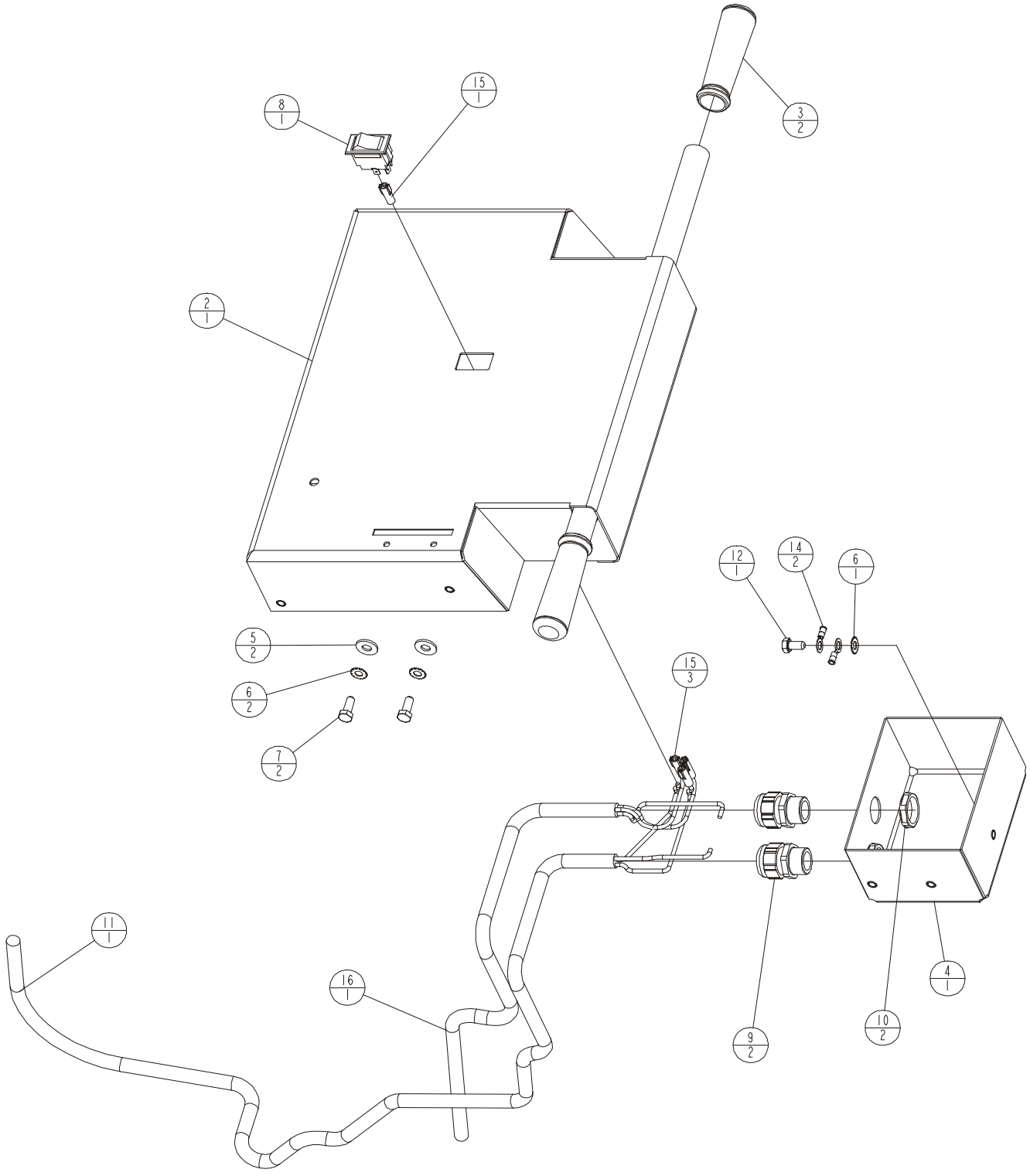
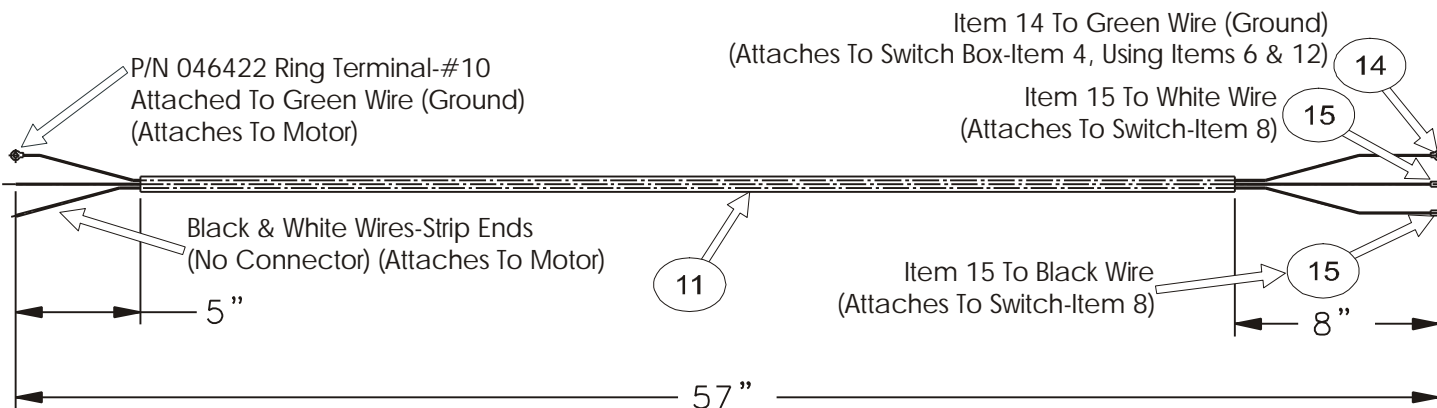
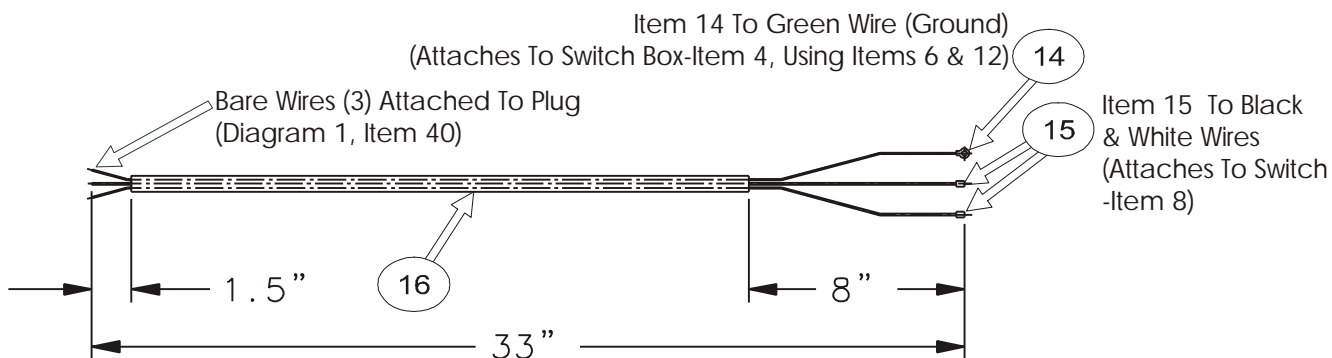

Diagram 3 Parts List – Handle Group, 1.5 hp Electric

ITEM	P/N	DESCRIPTION	QTY
1	-----	Handle Assembly - Electric	1
2	177786	Adjustable Handle Weldment	1
3	139568	Grip, Handle	2
4	177838	Switch Box Weldment	1
5	020742	Washer, Flat .313 Dia	2
6	173019	Lockwasher, External Tooth, M8	3
7	197227	Capscrew, Hex Hd M8 x 1.25 x 20mm	2
8	177747	Rocker Switch, 20A/1.5hp	1
9	182024	Strain Relief, 3/4 NPT	2
10	177746	Nylon Locknut, 3/4 NPT	2
11	177886	Electrical Cord, SO/SOW, 12/3 x 57 Inches	1
12	172028	Capscrew, Hex Hd M8 x 1.25 x 16mm (Full Thread)	1
13	197101	Wire Tie, .094 x 8.0 Lg (Thru Front Of Handle)	1
14	177288	Wire Connector, .312 Terminal Ring	2
15	167703	Wire Connector, .25 Female, Quick Connector	4
16	177885	Electrical Cord, SO/SOW, 12/3 x 33 Inches	1



Parts List Callout Designation:

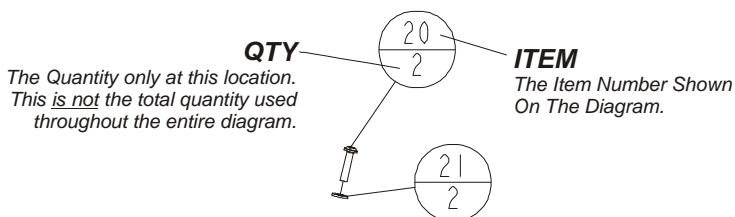

Diagram 4 – Handle Group, 11 hp Honda Gas

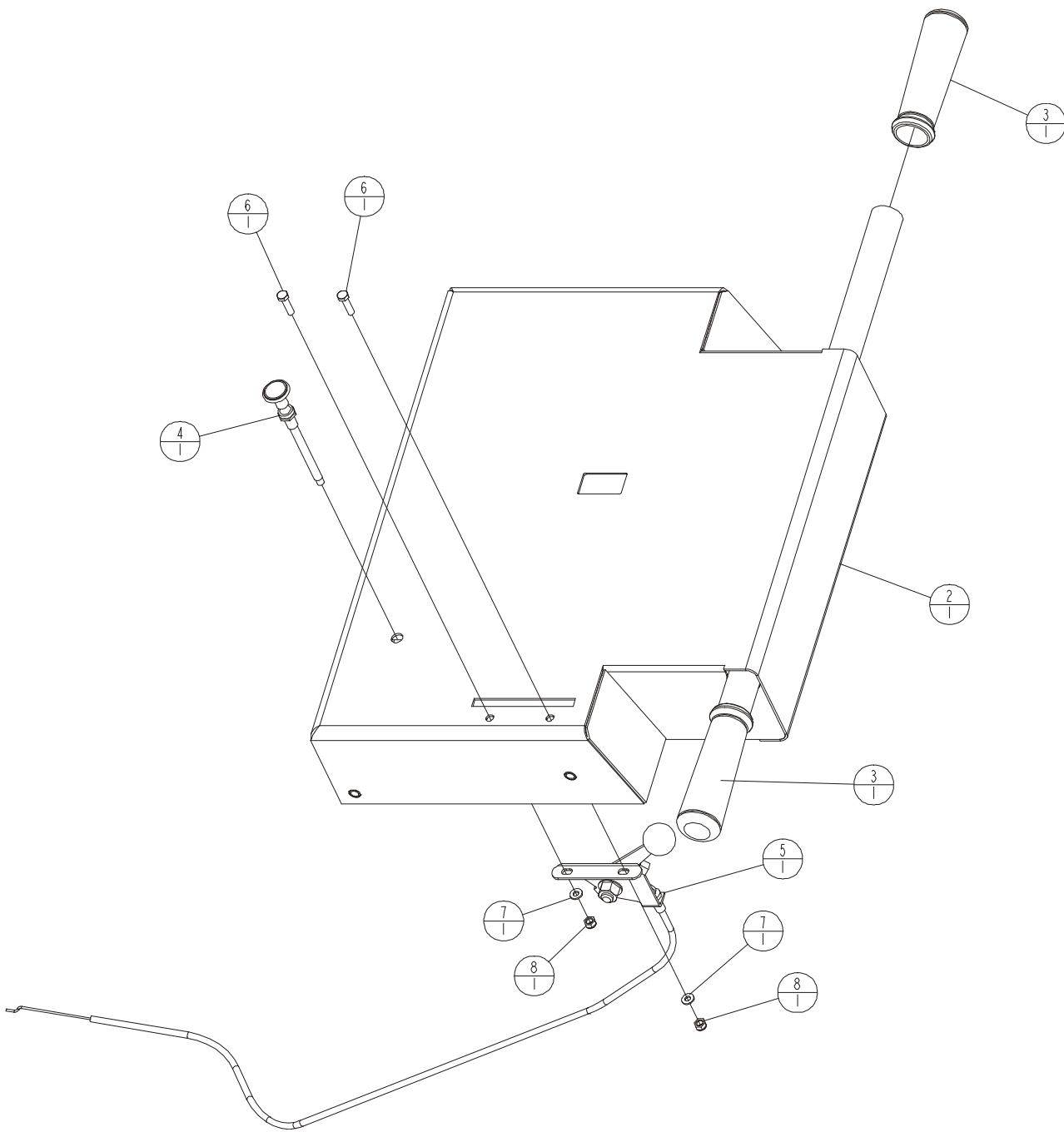

Diagram 4 Parts List – Handle Group, 11 hp Honda Gas

ITEM	P/N	DESCRIPTION	QTY
1	-----	Handle Assembly, Target Gas	1
2	177786	Adjustable Handle Weldment	1
3	139568	Grip, Handle	2
4	177836	Choke Cable Modified	1
5	177797	Cable Assembly, Engine Throttle Modified	1
6	167761	Capscrew, Hex Hd M5 x 0.8 x 20mm	2
7	173047	Washer, Flat M4	2
8	172316	Locknut, Fiber M5 x 0.8	2

Diagram 5 – Motor Group, 1.5 hp Electric

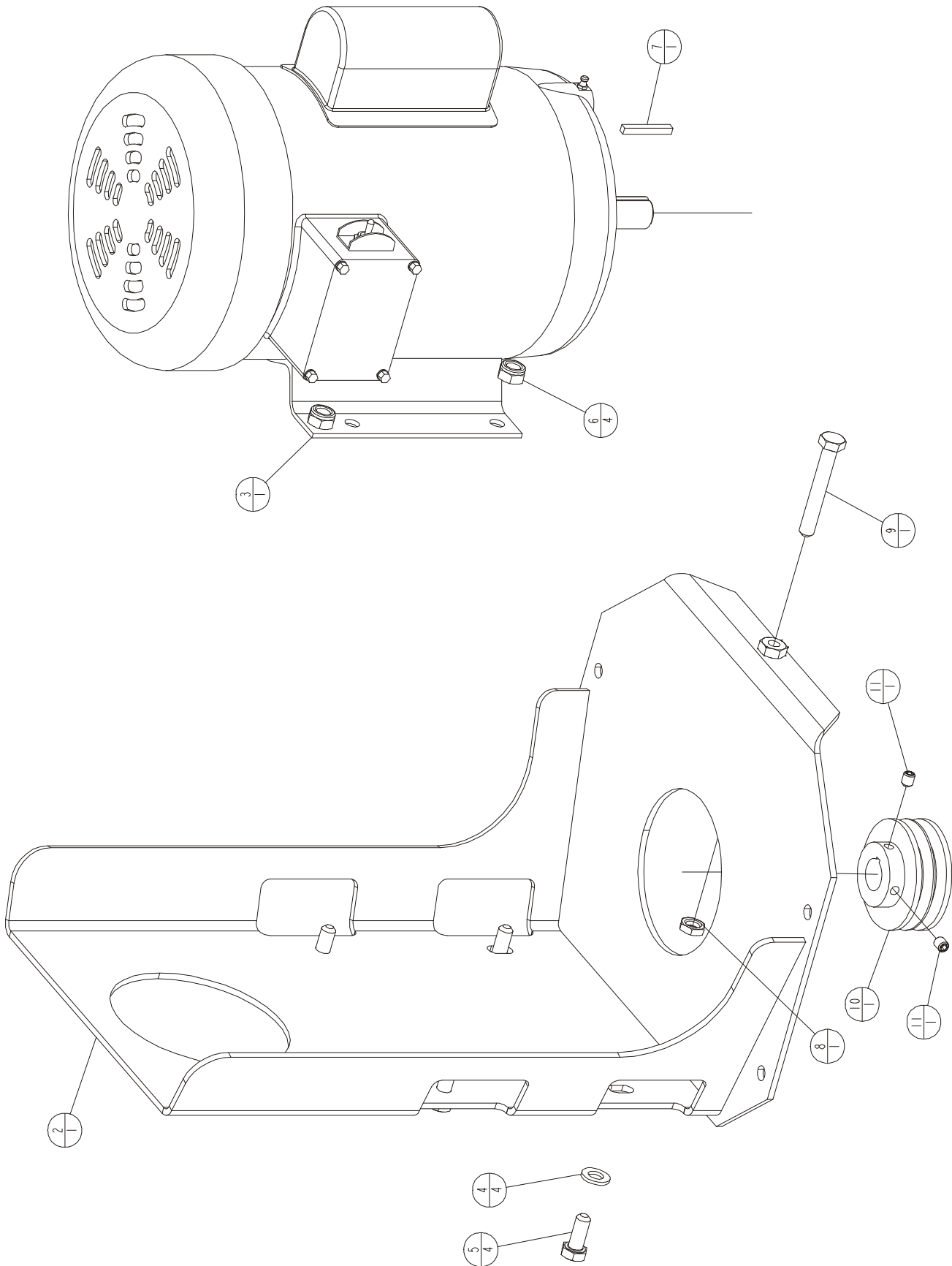

Diagram 5 Parts List – Motor Group, 1.5 hp Electric

ITEM	P/N	DESCRIPTION	QTY
1	-----	Motor Group	1
2	177789	Motor Base	1
3	177771	Motor, 1.5hp (1750 RPM)	1
4	173014	Washer, Flat M10	4
5	139749	Capscrew, Hex Hd M10 x 1.50 x 25mm	4
6	139748	Locknut, Fiber M10 x 1.50	4
7	020063	Key, Square .188 x 1.50 Lg	1
8	176222	Nut, Jam hex Hd M10 x 1.50	1
9	177884	Capscrew, Hex Hd M10 x 1.50 x 70mm (Full Thread)	1
10	030931	Pulley w/SS, 3V3.00-.875 Bore w/SS(Incl. Item 11)	1
11	020550	Screw, Set Soc Cup Pt .312-18UNC x .375	2

Parts List Callout Designation:

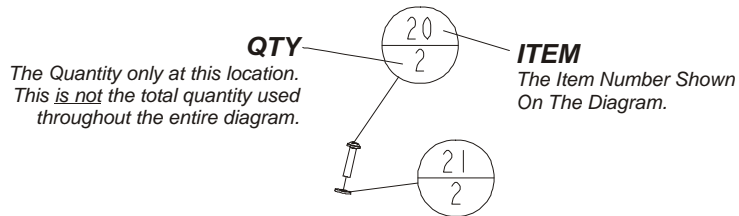

Diagram 6 – Engine Group, 11 hp Honda

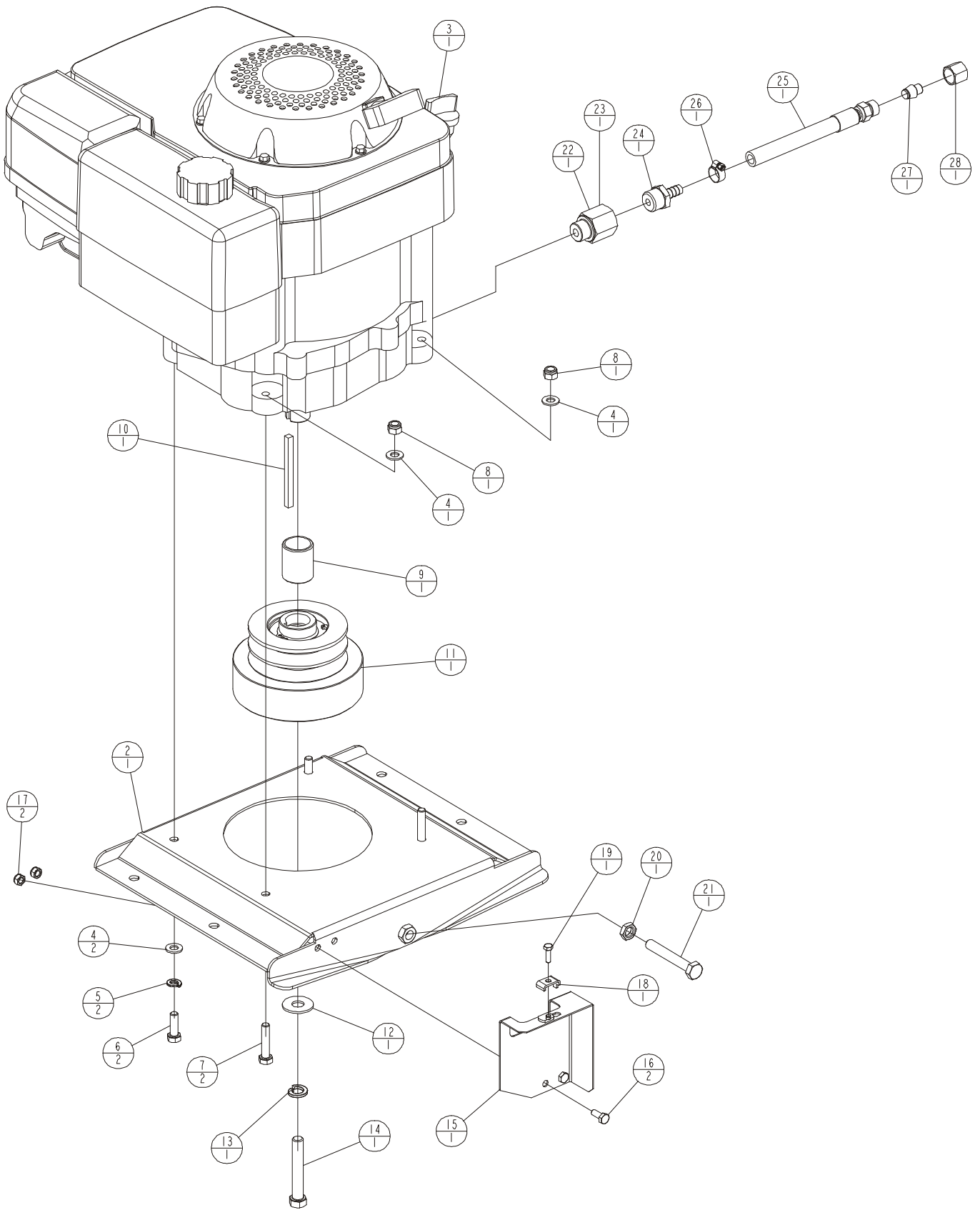

Diagram 6 Parts List – Engine Group, 11 hp Honda

ITEM	P/N	DESCRIPTION	QTY
1	-----	Engine Bench Assembly	1
2	177792	Engine Base	1
3	177764	Honda Engine, 11hp Model GXV340	1
4	020763	Washer, Flat .312 SAE	4
5	020785	Lockwasher, Split .312 Dia	2
6	020316	Capscrew, Hex Hd .312-18UNF x 1.00	2
7	020373	Capscrew, Hex Hd .312-18UNC x 1.50	2
8	020197	Locknut, Fiber .3125-18UNC	2
9	177766	Spacer, Engine Clutch	1
10	163130	Key, Square .250 x 3.25	1
11	177765	Clutch	1
12	020744	Washer, Flat .438 Dia	1
13	020787	Lockwasher, Split .438 Dia	1
14	177767	Capscrew, Hex Hd .438-20UNF x 2.75	1
15	177868	Switch Box Weldment	1
16	163688	Capscrew, Hex Hd M6 x 1.0 x 16mm	2
17	139745	Locknut, Fiber M6 x 1.0	2
18	CLIP	Included With Honda Engine	1
19	172315	Capscrew, Hex Hd M5 x 0.8 x 16mm	1
20	176222	Nut, Jam hex Hd M10 x 1.50	1
21	177884	Capscrew, Hex Hd M10 x 1.50 x 70mm (Full Thread)	1
22	177860	Fitting Assy, Oil Drain M20 x 1.5 x 3/8 Hose Barb	1
23	177859	Fitting, Connector, M20 Male x 1/2-14NPT Female	1
24	177017	Fitting, 1/2-14NPT x 3/8 Hose Barb	1
25	167305	Hose Assembly, Oil Drain	1
26	020049	Hose Clamp, Worm Drive	1
27	167306	Cap, Blanking	1
28	167622	Tube Nut, M16	1

Parts List Callout Designation:

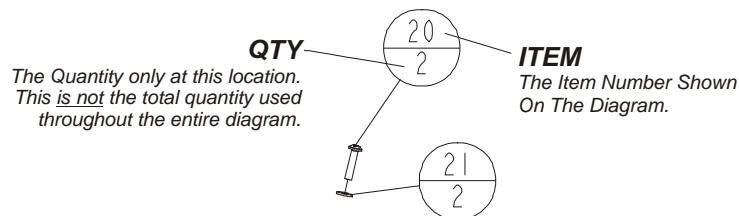

Diagram 7 – Gearbox Assembly, All Models

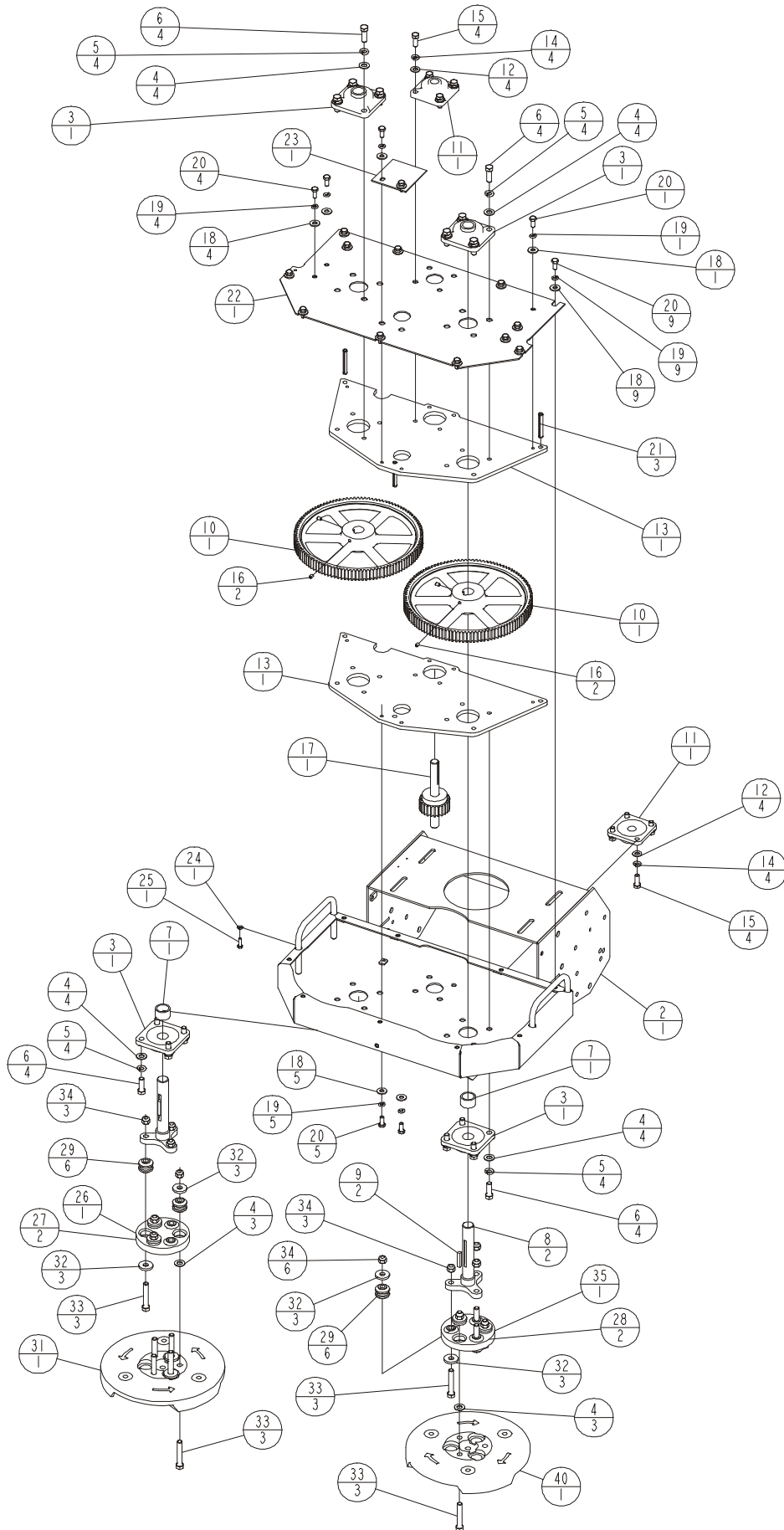

Diagram 7 Parts List – Gearbox Assembly, All Models

ITEM	P/N	DESCRIPTION	QTY
1	177842	Gearbox Assembly (Includes Items 2-45)	1
2	177834	Frame Weldment	1
3	177728	Bearing, 1.00 Dia Bore	4
4	177816	Washer, Flat .438 Dia SAE	16
5	020787	Lockwasher, Split .438 Dia	16
6	020375	Capscrew, Hex Hd .438-14UNC x 1.25	16
7	177733	Spacer, 112T Gear	2
8	177739	Spindle Shaft Weldment	2
9	020041	Key, Square .250 x 1.50 Lg	2
10	177729	Gear, 112T (Casting)	2
11	177734	Bearing, .750 Dia Bore	2
12	020764	Washer, Flat .375 SAE	8
13	177732	Plate, Bearing	2
14	020786	Lockwasher, Split .375 Dia	8
15	020323	Capscrew, Hex Hd .375-16UNC x 1.00	8
16	020541	Screw, Set Soc Cup Pt .250-20UNC x .375	4
17	177832	Gear & Shaft Weldment	1
18	020742	Washer, Flat .313 Dia	19
19	020785	Lockwasher, Split .312 Dia	19
20	197227	Capscrew, Hex Hd M8 x 1.25 x 20mm	19
21	177738	Roll Pin, .375 Dia x 2.50	3
22	177835	Top Gearbox Cover	1
23	177874	Lubrication Port Cover	1
24	020784	Lockwasher, Split .250 Dia	1
25	139761	Capscrew, Hex Hd M6 x 1.0 x 20mm	1
26	-----	Accessory Disk Assembly, RH - Complete	1
27	177847	Drive Plate Assy (Includes Items 28-29)	1
28	-----	Drive Plate	1
29	177727	Isolator, Rubber	6
30	177816	Washer, Flat .438 Dia SAE	3
31	177742	Disk, RH (Machined)	1
32	177947	Washer, Sp 1.25 OD x .469 ID x .188	6
33	176136	Capscrew, Hex Hd .438-14UNC x 2.50	6
34	020210	Locknut, Fiber .438-14UNC	3
35	-----	Accessory Disk Assembly, LH - Complete	1
36	177847	Drive Plate Assy (Includes Items 37-38)	1
37	-----	Drive Plate	1
38	177727	Isolator, Rubber	6
39	177816	Washer, Flat .438 Dia SAE	3
40	177744	Disk, LH (Machined)	1
41	177947	Washer, Sp 1.25 OD x .469 ID x .188	6 (Effective S/N 323831)
42	176136	Capscrew, Hex Hd .438-14UNC x 2.50	6
43	020210	Locknut, Fiber .438-14UNC	3
44	020210	Locknut, Fiber .438-14UNC	6
45	177763	Grease (Qty in Ounces)	24

Diagram 8 – Water Tank Kit (Optional) – P/N 177855 Complete Kit

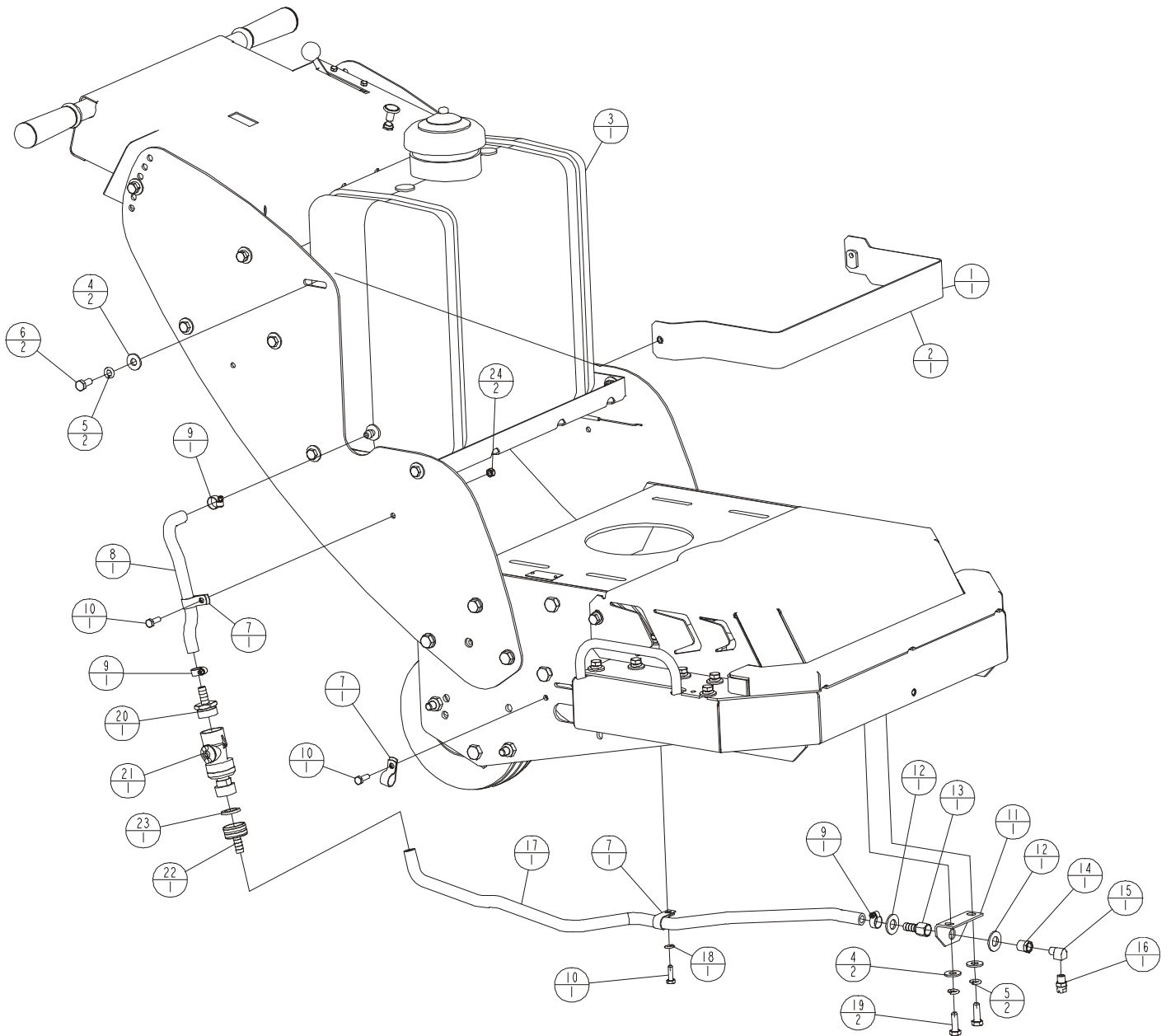

Diagram 8 Parts List – Water Tank Kit (Optional) – P/N 177855 Complete Kit

ITEM	P/N	DESCRIPTION	QTY
1	177855	Water Tank Kit (Complete-Includes Items 2 - 24)	1
2	177778	Water Tank Bracket	1
3	174648	Water Tank (w/ Cap), 7 Gallon	1
3a	178863	Cap, Water Tank, 7 Gallon	1
4	020742	Washer, Flat .313 Dia	4
5	020785	Lockwasher, Split .312 Dia	4
6	197227	Capscrew, Hex Hd M8 x 1.25 x 20mm	2
7	166673	Clamp, Vinyl Coated 1/4 Hole x 5/8 ID	3
8	139722B	Hose, 3/8 ID (139722 Bulk Qty In Inches = 8.5)	1
9	020049	Hose Clamp, Worm Drive	3
10	139761	Capscrew, Hex Hd M6 x 1.0 x 20mm	3
11	177813	Water Outlet Bracket	1
12	020766	Washer, Flat .500 SAE	2
13	030654	Adapter, 1/4 NPT x 3/8 Barb	1
14	020875	Bushing, Hex 1/4 NPT Male x 1/8 NPT Female	1
15	020811	Fitting, Elbow, Street 1/8 NPT x 90 Degree	1
16	048902	Nozzle, 1/8 NPT	1
17	139722A	Hose, 3/8 ID (139722 Bulk Qty In Inches = 25)	1
18	020784	Lockwasher, Split .250 Dia	1
19	167478	Capscrew, Hex Hd M8 x 1.25 x 25mm	2
20	174016	Fitting, Hose Barb 3/8 ID x 3/4 Male	1
21	174741	Kit: Quick Disconnect Garden Hose w/Valve	1
22	174020	Fitting, Hose Barb 3/8 ID x 3/4 Female	1
23	040254	Washer, Hose	1
24	139745	Locknut, Fiber M6 x 1.0	2

Assembly of Kit (Use Diagram 8 for reference):

1. *Before starting the assembly of this kit:*
 - a) *To improve access to the underside of the gearbox, it may be required to temporarily remove the Front Shield (Diagram 1- Item 18 or Diagram 2 - Item 28). Be sure to re-install this item when this kit is completely installed. Do Not remove the Dust Port Weldment (Diagram 1- Item 19, or Diagram 2 – Item 29), even if it must be temporarily held in place with its attaching hardware.*
 - b) *Make sure that the Valve (Item 21) is assembled so that when the valve halves are disconnected, the ON / OFF lever is located on the water tank side of the assembly. This will allow removal of the tank from the machine, even if it contains water.*
 - c) *Rotate the Dust Shield Cover (Diagram 1 – Item 20, or Diagram 2 – Item 30) to the open position by loosening the two (2) Capscrews that hold it in position. Tighten the hardware to secure the Dust Shield Cover in the OPEN position.*
2. *Assemble the Water Outlet Bracket (Item 11) to the underside of the gearbox. Remove the two (2) existing Capscrews located under the gearbox at the front of the machine. The fittings could be already assembled, but if not assemble them as shown in Diagram 8.*
3. *Secure the Water Tank (Item 3) in position by using the Bracket (Item 2) and attaching hardware.*
4. *Attach the Hose (Item 8) to the Water Tank (Item 3) and secure the Hose Clamp (Item 9). Again, make sure that the Water Valve (Item 21) is properly assembled (Per Note 1b shown above).*
5. *Route the Hoses (Item 8 & Item 17) as shown in Diagram 8. Be sure to route the hose through the side of the frame, and through the open Dust Shield Cover (Step 1c). Put the Hose Clamp (Item 9) onto the Hose (Item 17), and then push the hose over the end of the Hose Adapter (Item 13). Securely tighten the Clamp onto the barb end of the Adapter.*
6. *Install the Vinyl Hose Clamps (Item 7) in the positions shown in Diagram 8.*
7. *Re-install the Front Shield if it was removed in step 1a.*

Diagram 9 – Weight Kit (Optional) – P/N 177856 Complete Kit

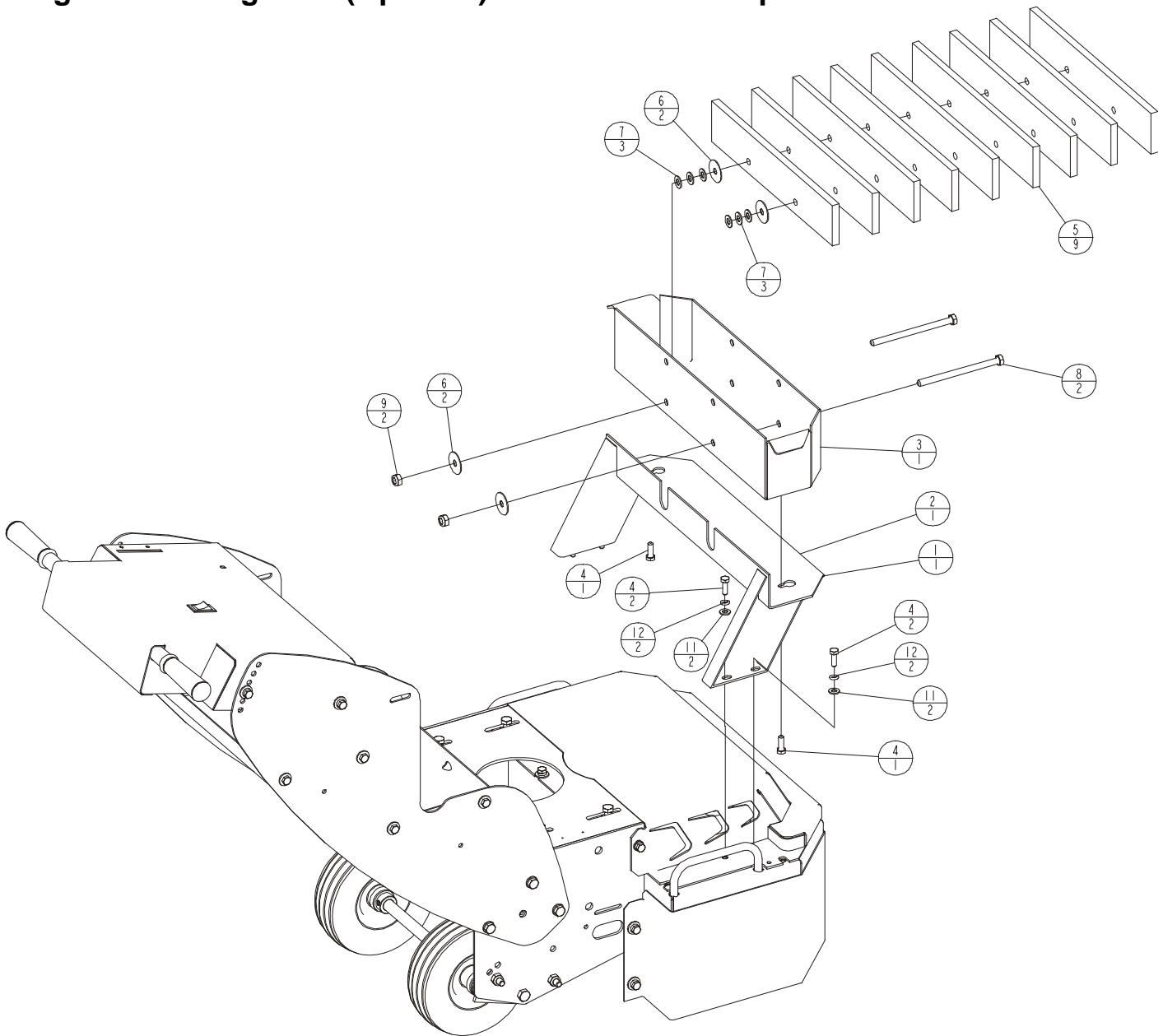

Diagram 9 Parts List – Weight Kit (Optional) – P/N 177856 Complete Kit

ITEM	P/N	DESCRIPTION	QTY
1	177856	Weight Kit (Complete-Includes Items 2-12)	1
2	177809	Weight Tray Weldment	1
3	177811	Weight Box Weldment	1 [Max. Capacity: 18 Bars (Item 5)]
4	167478	Capscrew, Hex Hd M8 x 1.25 x 25mm	6
5	180418	Bar, Weight, (6.5 Lbs. each)	9
6	177890	Washer, Flat 1.50 OD x .406 ID x .062 Thk	4
7	020764	Washer, Flat .375 SAE	6
8	166613	Capscrew, Hex Hd M10 x 1.50 x 150mm	2
9	139748	Locknut, Fiber M10 x 1.50	2
10	071331	Carton, Plain	1
11	020763	Washer, Flat .312 SAE	4
12	020785	Lockwasher, Split .312 Dia	4

Diagram 10 – Diamond Disk Adapter Kit (Optional) – P/N 177861 Complete Kit

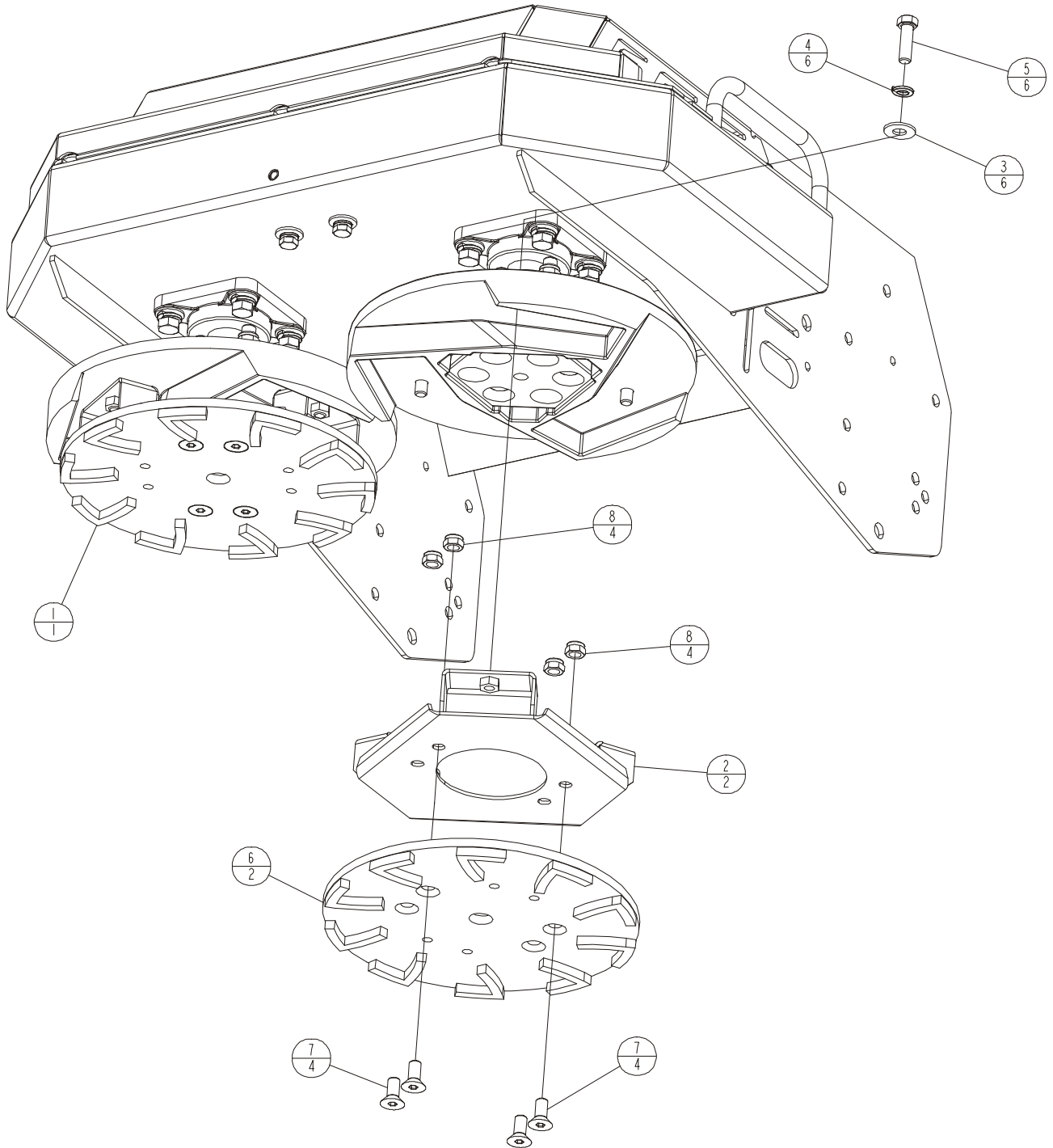

Diagram 10 Parts List – Adapter Kit (Optional) – P/N 177861 Complete Kit

ITEM	P/N	DESCRIPTION	QTY
1	177861	Adapter Kit, Diamond Disk (Item 2-5, 7, 8)	1
2	177887	Diamond Disk Adapter	2
3	020743	Washer, Flat .375 Dia	6
4	020786	Lockwasher, Split .375 Dia	6
5	048740	Capscrew, Hex Hd .375-16UNC x 1.25	6
6	-----	Diamond Disk, 10 Inch Dia (Not Included)	2
7	177889	Capscrew, Soc Flat Hd .375-16UNC x .875	8
8	020199	Locknut, Fiber .375-16UNC	8

Diagram 11 – Star Cutter Assy, P/N 177825 (6 Required per Machine)

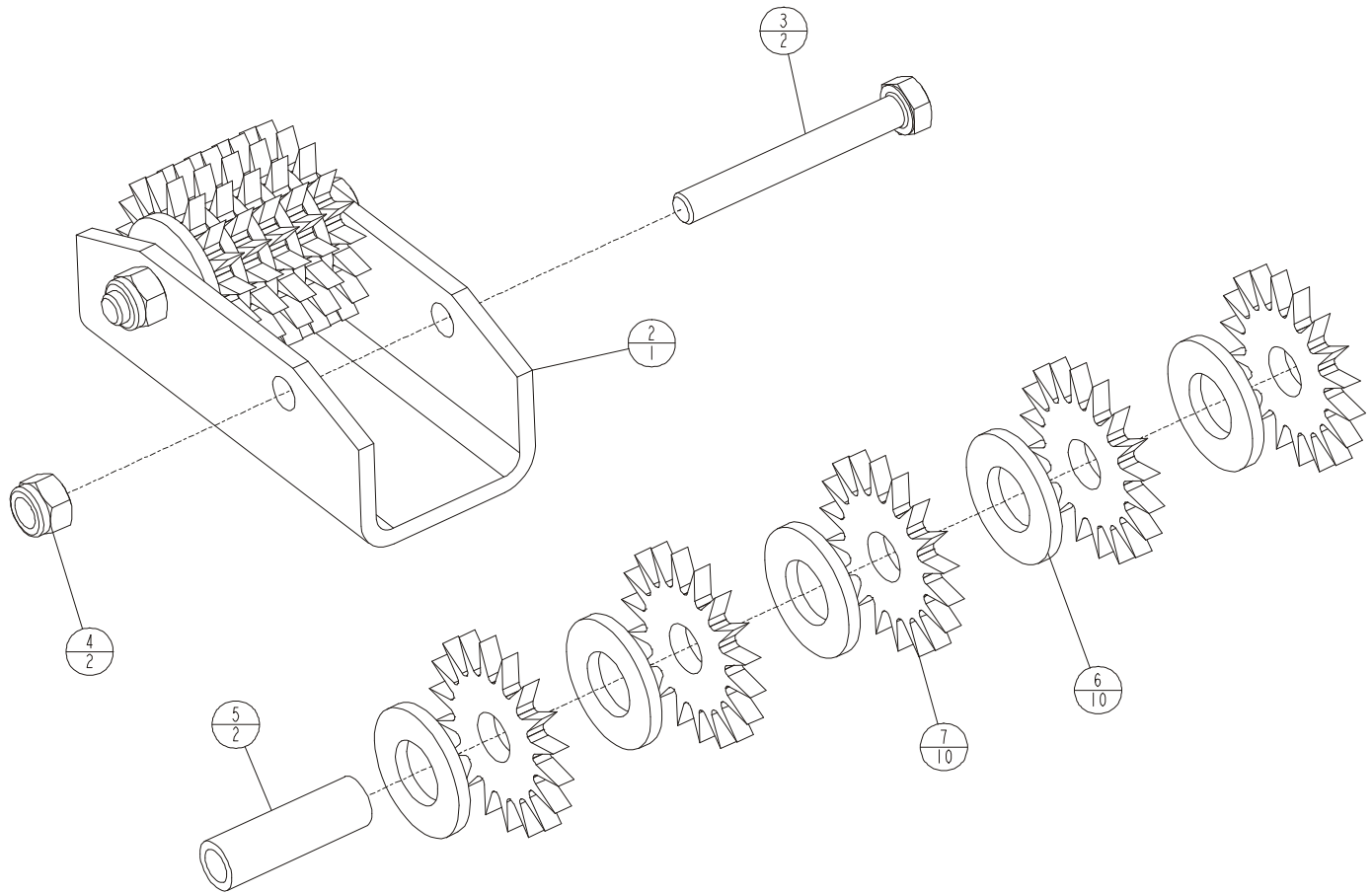

Diagram 11 Parts List – Star Cutter Assy – P/N 177825 (6 Required Per Machine)

ITEM	P/N	DESCRIPTION	QTY
1	177825	Star Cutter Assembly	1
2	177862	Cutter Wheels Bracket	1
3	020354	Capscrew, Hex Hd .312-18UNC x 2.50	2
4	020197	Locknut, Fiber .3125-18UNC	2
5	177865	Cutter Wheel Spacer, 1/2 OD	2
6	020767	Washer, Flat, .625 Dia SAE	12

Note: Depending on their thickness, 2 washers (Item 6) could be required on one end of each row of cutters. If the washers are thicker, then the quantity (10) shown in the diagram will be correct, and 2 washers can be eliminated from the assembly.

7	177826	Star Cutter Wheel	10
---	--------	-------------------	----

Parts List Callout Designation:

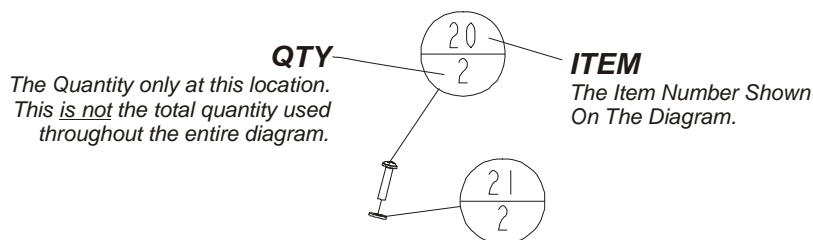

Diagram 12 – Beam Cutter Assy, P/N 177827 (6 Required per Machine)

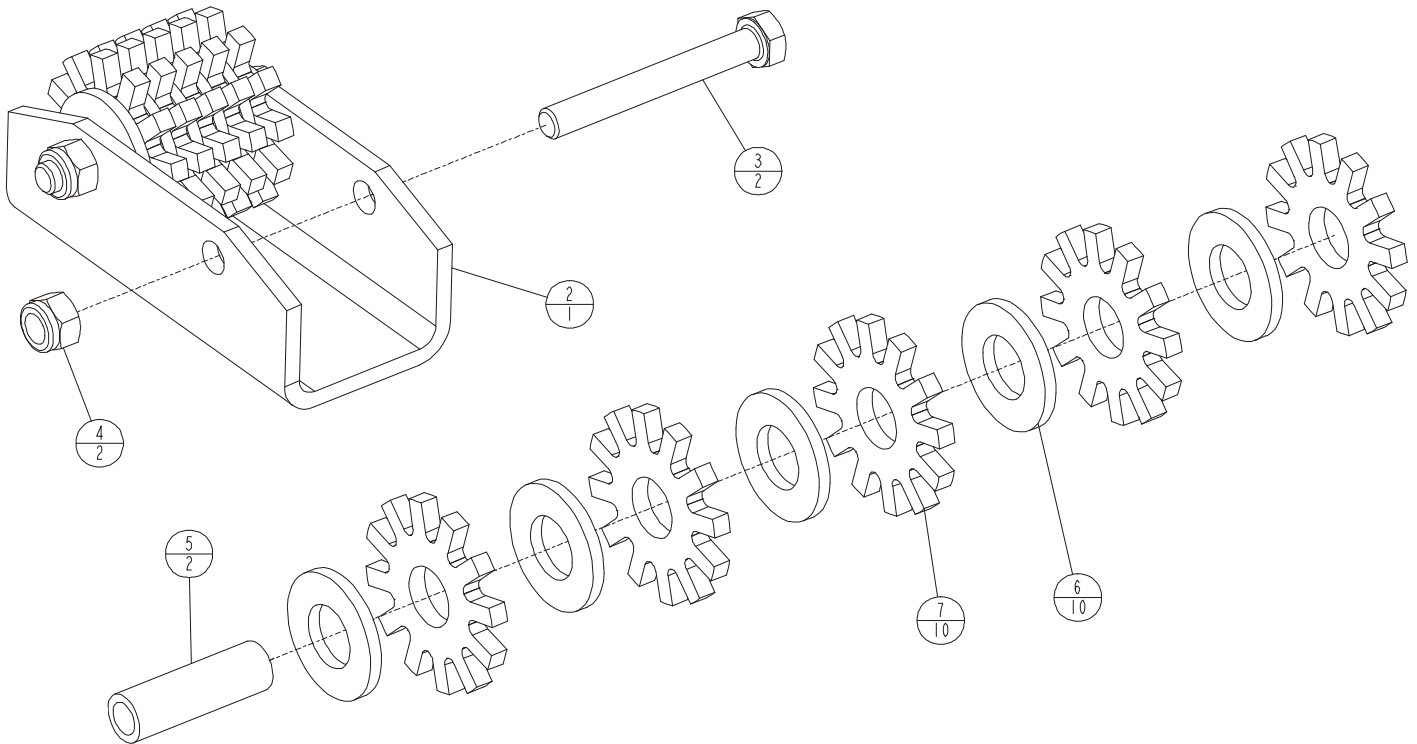

Diagram 12 Parts List – Beam Cutter Assy – P/N 177827 (6 Required Per Machine)

ITEM	P/N	DESCRIPTION	QTY
1	177827	Beam Cutter Assembly	1
2	177862	Cutter Wheels Bracket	1
3	020354	Capscrew, Hex Hd .312-18UNC x 2.50	2
4	020197	Locknut, Fiber .3125-18UNC	2
5	177865	Cutter Wheel Spacer, 1/2 OD	2
6	020767	Washer, Flat, .625 Dia SAE	12

Note: Depending on their thickness, 2 washers (Item 6) could be required on one end of each row of cutters. If the washers are thicker, then the quantity (10) shown in the diagram will be correct, and 2 washers can be eliminated from the assembly.

7	177828	Beam Cutter Wheel	10
---	--------	-------------------	----

Parts List Callout Designation:

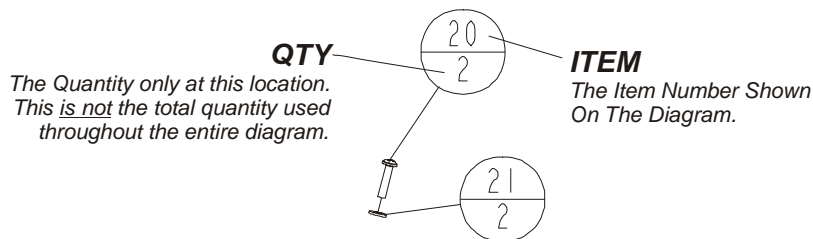

Diagram 13 – Tungsten Carbide Cutter Assy, P/N 177829

(6 Required per Machine)

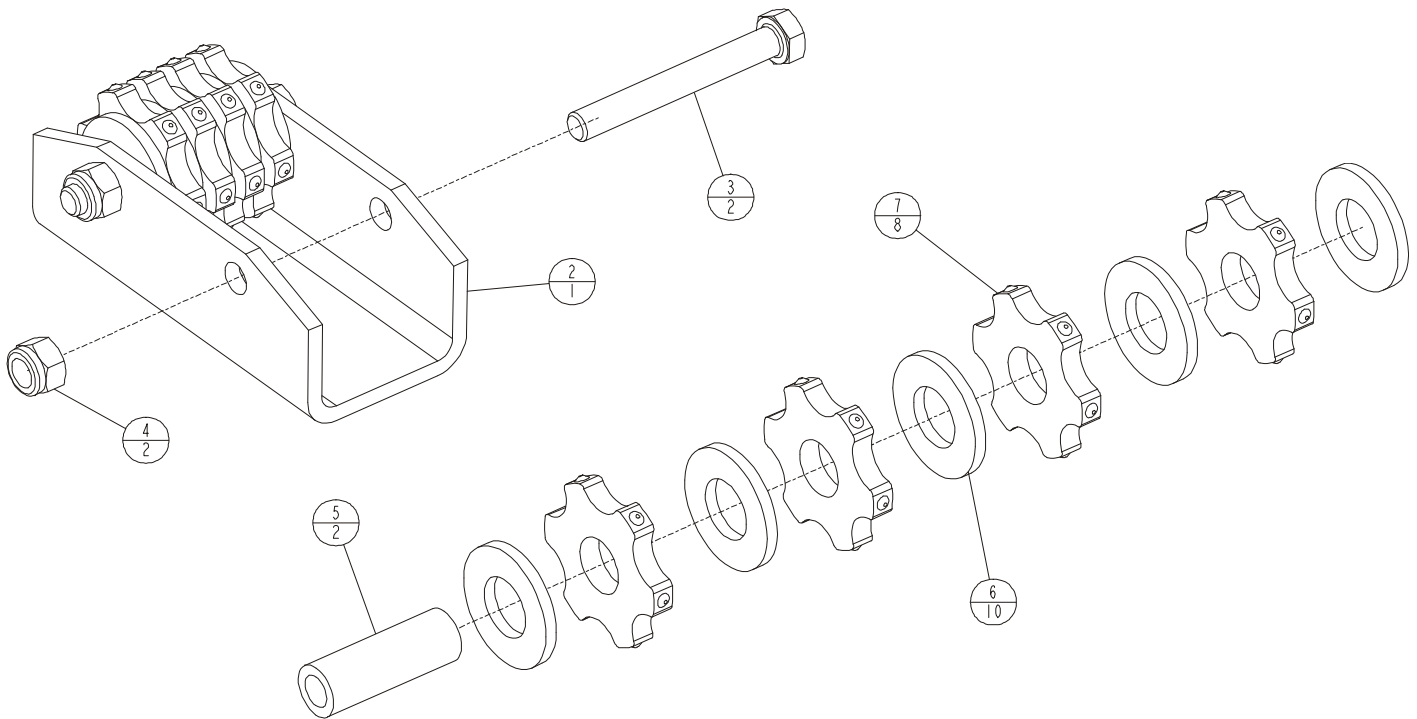

Diagram 13 Parts List – Tungsten Carbide Cutter Assy – P/N 177829

(6 Required Per Machine)

1	177829	TC Cutter Assembly	1
2	177862	Cutter Wheels Bracket	1
3	020354	Capscrew, Hex Hd .312-18UNC x 2.50	2
4	020197	Locknut, Fiber .3125-18UNC	2
5	177864	Cutter Wheel Spacer, 5/8 OD	2
6	020767	Washer, Flat, .625 Dia SAE	10
7	177830	TC Cutter Wheel	8

Parts List Callout Designation:

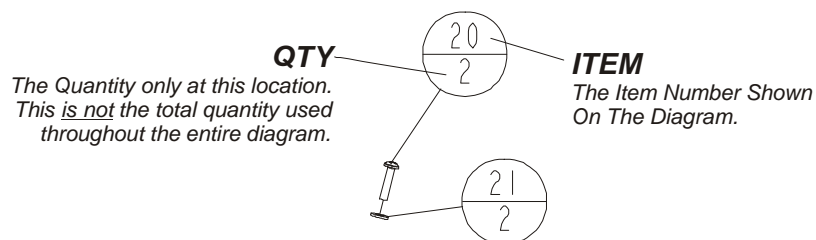

Diagram 14 – Tungsten Carbide Block Assy (Complete Kit P/N 177823)

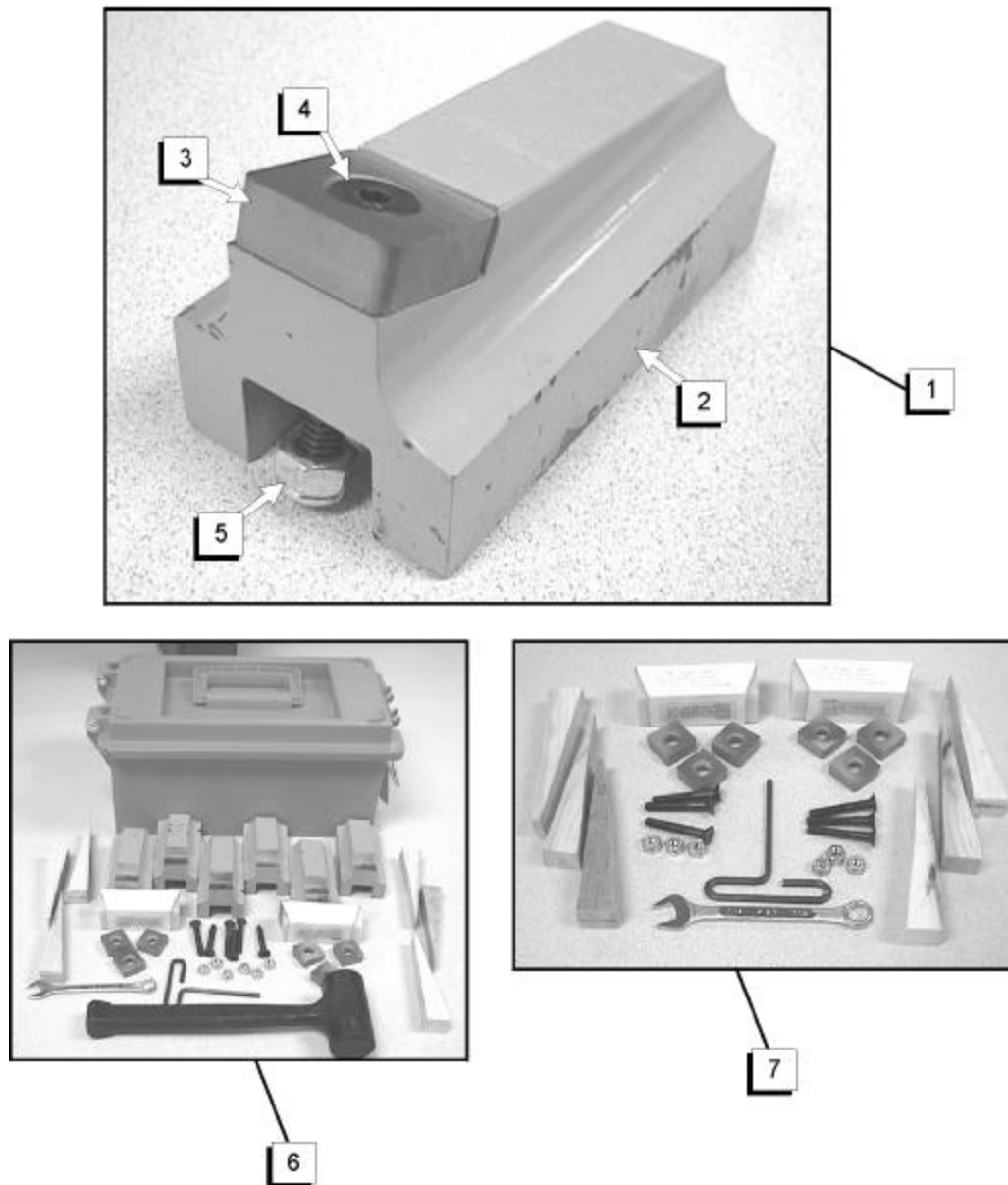
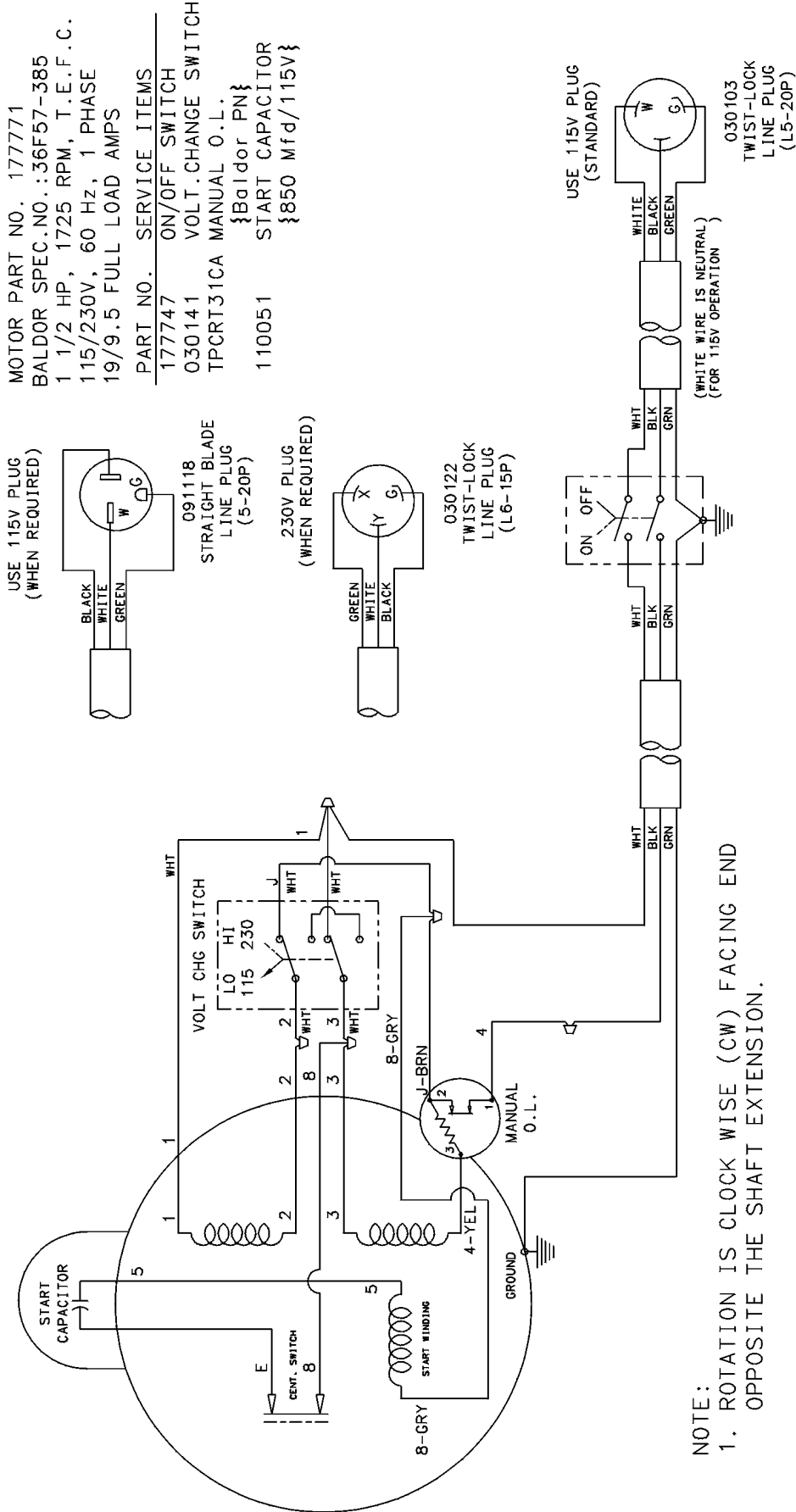

Diagram 14 Parts List – Tungsten Carbide Block Assy

ITEM	P/N	DESCRIPTION	QTY
1	190097	Carbide Cutter Assy (Includes Items 2-5)	1
2	-----	Block, Cutter	1
3	-----	Cutter, Tungsten Carbide	1
4	-----	Screw, Flat Socket Head, ¼-20 x 1.75" Lg.	1
5	020195	Locknut, Fiber, ¼-20UNC	1
6	177823	Kit, Complete, Tungsten Carbide Cutter (Includes 6 Blocks, 6 Tungsten Carbide Cutters, Hardware, Installation Tools, 6 Wooden Wedges, and Carrying Case)	1
7	177824	Kit, Replacement Cutters (Includes 6 Tungsten Carbide Cutters, 6 Wooden Wedges, Hardware, and Tools To Mount Cutters)	1

Note: Nut (Item 5) Shown Loose For Photographic Purposes Only.

Diagram 15 - Wiring Diagram, 1.5hp Electric Model



Target Corporate Office

Customer Service 800-288-5040
Corp. Office 913-928-1000
Cust. Service FAX 800-825-0028
Corp. Office FAX 913-438-7951
Cust. Service, Int'l. 913-928-1300
Int'l. E-mail..... rcoats@db-inc.com

**Target Latin America, Mexico, Caribbean,
Central and South America**

17400 West 119th Street
Olathe, Kansas 66061

Phone 913-928-1255
FAX 913-438-7938
E-mail hleon@db-inc.com

Target Canada

17400 West 119th Street
Olathe, Kansas 66061

Customer Service 800-288-5040
E-mail rbaker@db-inc.com

Target Hong Kong, China

Diamant Boart Pte Ltd.
Unit E, 13/F., Infotech Centre,
21 Hung To Road, Kwun Tong,
Hong Kong

Phone 852-2516-6602
FAX 852-2516-6605
E-mail targethk.netvigator.com

Target Japan, Korea, Taiwan

1803-36 Oyama-Machi
Machida-Shi, Tokyo 194-0212
Japan

Phone 8142-797-0212
FAX 8142-798-7515
E-mail fwnh9794@mb.infoweb.ne.jp

Target Australia, New Zealand/Dembicon Pty. Ltd

29 Kinkaid Avenue
North Plympton, Adelaide SA 5037
Australia

Phone 61-83751000
FAX 61-83710990
E-mail enquiries@dembicon.com.au
Internet www.dembicon.com.au

**Target Brazil
Pix Do Brasil**

Rua José de Oliveira Coutinho
São Paulo, Brazil CEP 01144-020

Phone 55 11 3611-8383
FAX 55 11 3619-3022
E-mail pixbrasil@uol.com.br

**Target Singapore, Thailand, Vietnam,
Malaysia, Indonesia**



Phone 65-9628-6175
FAX 65-234-2896
e-mail reeh@singnet.com.sg

**European Headquarters
DB Construction Business Group**

Avenue Du Pont De Luttre, 74
1190 Brussels, Belgium

Phone (32-2) 348-3669
FAX (32-2) 348-3136
Internet www.diamant-boart.com

Target Internet www.targetblue.com

 **WARNING** 
The engine exhaust from this product contains chemicals known to the State of California to cause cancer, birth defects or other reproductive harm.



Free Manuals Download Website

<http://myh66.com>

<http://usermanuals.us>

<http://www.somanuals.com>

<http://www.4manuals.cc>

<http://www.manual-lib.com>

<http://www.404manual.com>

<http://www.luxmanual.com>

<http://aubethermostatmanual.com>

Golf course search by state

<http://golfingnear.com>

Email search by domain

<http://emailbydomain.com>

Auto manuals search

<http://auto.somanuals.com>

TV manuals search

<http://tv.somanuals.com>