

KENWOOD  
**kMix**

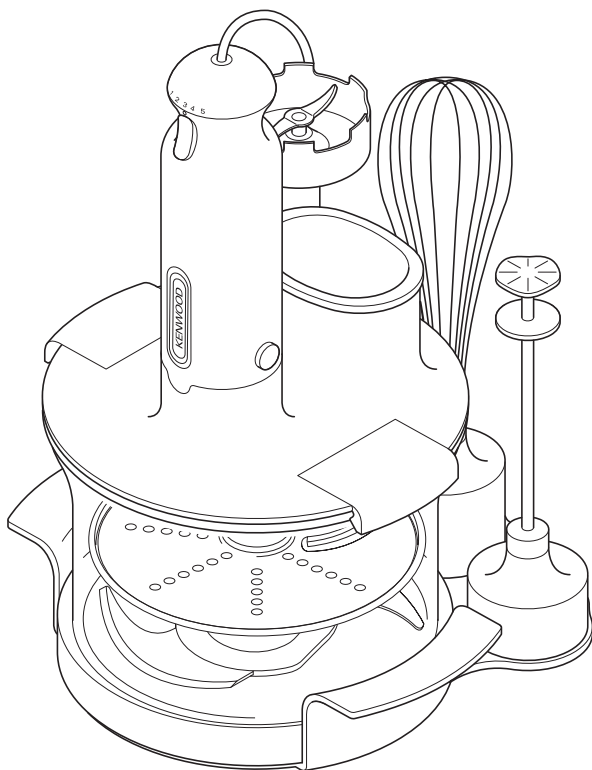

HB790 series

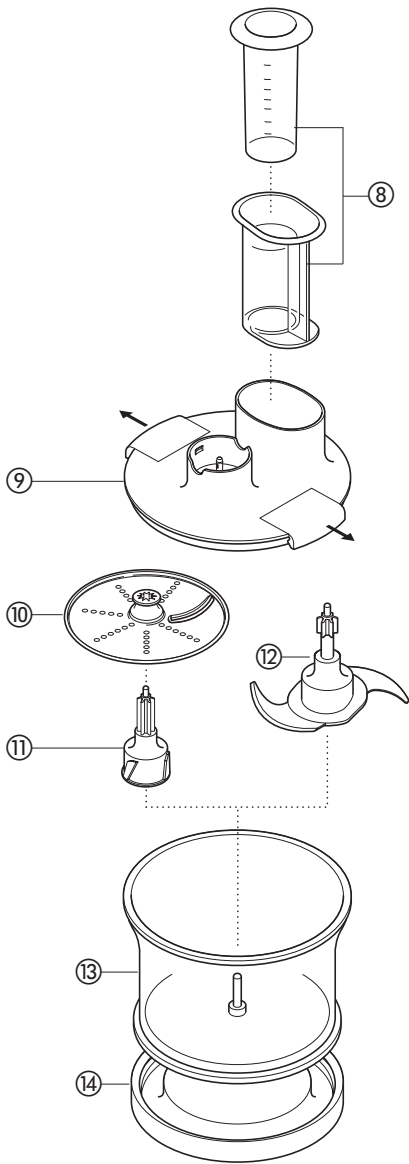

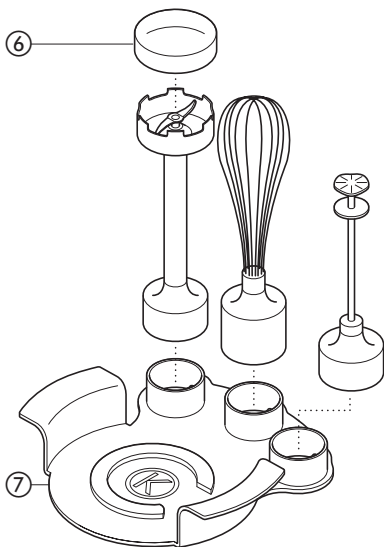
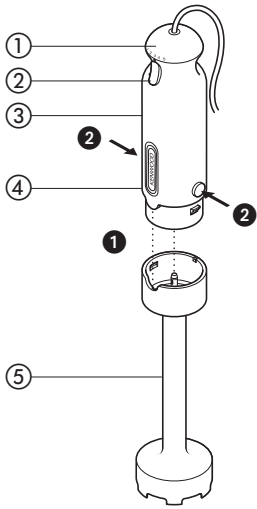
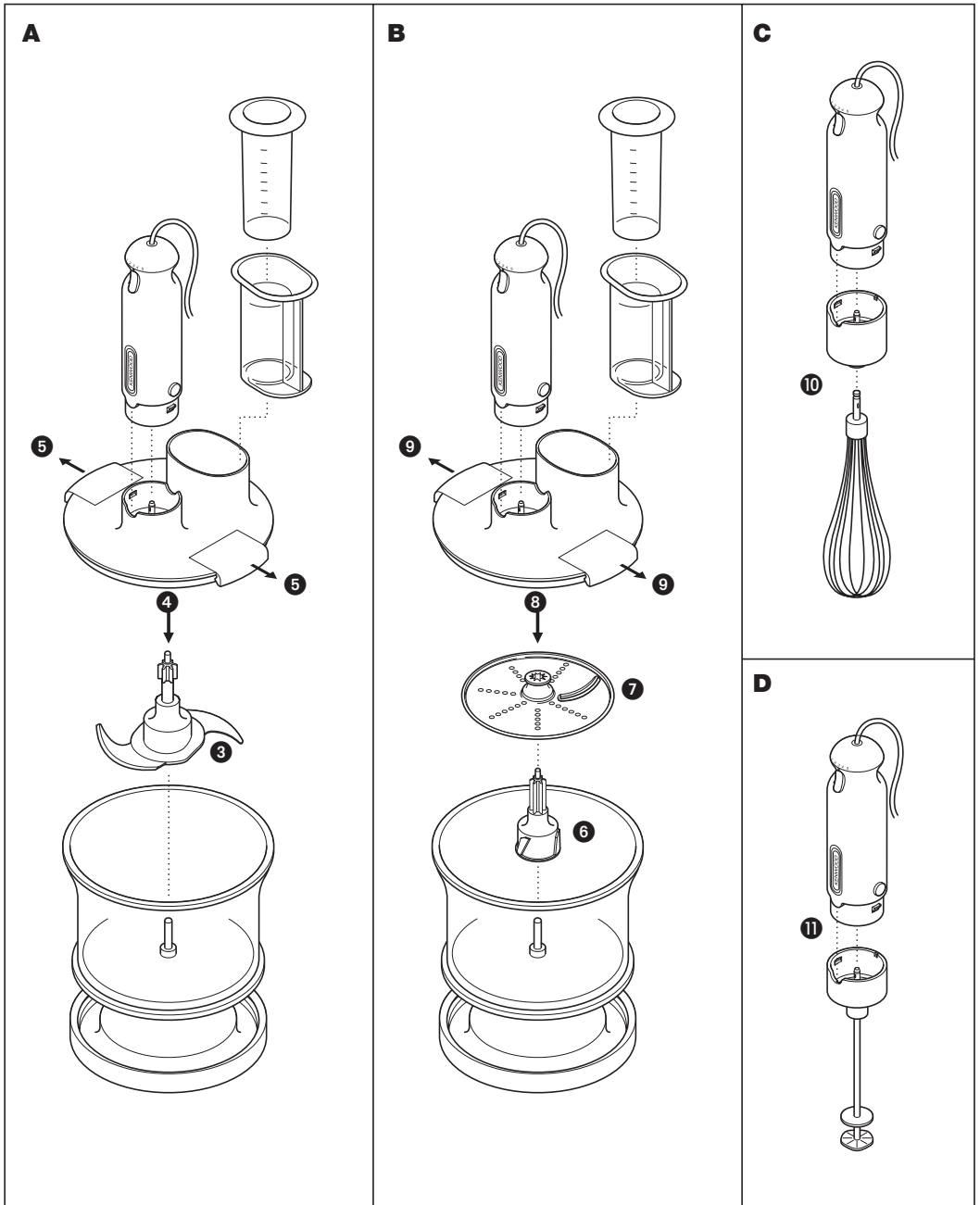

### **before using your Kenwood appliance**

- Read these instructions carefully and retain for future reference.
- Remove all packaging and any labels.
- Remove the blade cover ④.
- Wash all parts - see "care and cleaning".

## safety

### **general**

- Take special care when preparing food for babies, the elderly and infirm. Always ensure that the hand blender shaft is thoroughly sterilised. Use a sterilising solution in accordance with the sterilising solution manufacturers instructions.
- Never touch the blades while the machine's plugged in.
- Keep fingers, hair, clothing and utensils away from moving parts.
- Unplug after use and before changing attachments.
- Never blend hot oil or fat.
- Never use a damaged hand blender. Get it checked or repaired: see 'service'.
- Never put the power handle in water or let the cord or plug get wet - you could get an electric shock.
- Never let the cord touch hot surfaces or hang down where a child could grab it.
- Never use an unauthorised attachment.
- Always disconnect the hand blender from the supply if it is left unattended and before assembling, disassembling or cleaning.
- Do not allow children to use the hand blender without supervision.
- This appliance is not intended for use by persons (including children) with reduced physical, sensory or mental capabilities, or lack of experience and knowledge, unless they have been given supervision or instruction concerning use of the appliance by a person responsible for their safety.
- Children should be supervised to ensure that they do not play with the appliance.
- Only use the appliance for its intended domestic use. Kenwood will not accept any liability if the appliance is subject to improper use, or failure to comply with these instructions.

### **food processor attachment**

- The knife blade and disc are very sharp, handle with care. **Always hold the knife blade at the top and disc by the finger grip, away from the cutting edge, both when handling and**

### **cleaning.**

- Always remove the knife blade or disc before emptying the bowl.
- Never remove the cover until either the blade or disc has completely stopped.

### **important**

- With heavy mixtures, don't use your hand blender for longer than 50 seconds in any four minute period - it'll overheat.

### **before plugging in**

- Make sure your electricity supply is the same as the one shown on the hand blender.

### **Important - UK only**

- The wires in the cord are coloured as follows:  
Blue = Neutral  
Brown = Live.
- The appliance must be protected by a 13A approved (BS1362) fuse.

### **Note:**

- For non-rewireable plugs the fuse cover **MUST** be refitted when replacing the fuse. If the fuse cover is lost then the plug must not be used until a replacement can be obtained. The correct fuse cover is identified by colour and a replacement may be obtained from your Kenwood Authorised Repairer (see Service).
- If a non-rewireable plug is cut off it must be **DESTROYED IMMEDIATELY**. An electric shock hazard may arise if an unwanted non-rewireable plug is inadvertently inserted into a 13A socket outlet.
- Your hand blender complies with European Economic Community Directive 89/336/EEC.

## key

### hand blender

- ① 5 speed control
- ② ON/OFF button
- ③ power handle
- ④ blender shaft release buttons
- ⑤ metal blender shaft with fixed blade.
- ⑥ blade cover
- ⑦ storage unit

### food processor attachment

- ⑧ pushers
- ⑨ cover
- ⑩ slicing/shredding disc
- ⑪ disc drive shaft
- ⑫ knife blade
- ⑬ bowl
- ⑭ non-slip removable base

### whisk

- ⑮ whisk collar
- ⑯ wire whisk

### frother

- ⑰ frother shaft

### to use the hand blender

- You can blend baby food, soups, sauces, milk shakes and mayonnaise for example.

### for saucepan blending

- Take care when blending hot liquids - take the pan off the heat and let it cool before blending.

1 Fit the blender shaft to the power handle ① – push to lock.

2 Plug in.

- **To avoid splashing, place the blade in the food before switching on.**

3 Select the required speed by rotating the speed control and switch on. (Use speed 1 and 2 for slower blending).

- Don't let liquid get above the join between the power handle and blender shaft.
- Move the blade through the food and use a mashing or stirring action to incorporate the mixture.
- Your hand blender is not suitable for ice crushing.
- If your blender gets blocked, unplug before clearing.

4 After use, unplug and press the release buttons ② to remove the blender shaft from the power handle.

### food processor attachment

#### A to use the knife blade

- The knife blade is very sharp, take care when handling.
- Don't process hard foods such as coffee beans, ice cubes, spices or chocolate as they will damage the blade.
- When chopping meat remove any bones and cut into 2cm (3/4 in) cubes.

- 1 Fit the non-slip base onto the bottom of the bowl.
- 2 Fit the knife blade over the pin in the bowl ③. Always fit the knife blade before adding ingredients.
- 3 Fit the cover and push down to lock in place ④.
- 4 Fit the power handle and push to lock in place. The power handle can be fitted with the ON/OFF button either facing inwards or outwards.
- 5 Plug in and hold the bowl steady. Then select a speed and switch on.
- 6 After use, unplug and dismantle. To remove the lid pull both locking clips out together and lift ⑤.

#### hints

- Use the knife blade for cake and pastry making, chopping meat, cheese, vegetables, herbs, nuts, dips and to also make crumbs from bread and biscuits. **The attachment is not suitable for making bread dough.**
- Pastry making - use fat straight from the fridge cut into 2cm/ 1/2in cubes and process until the mixture looks like coarse breadcrumbs. Add the water down the feed tube and stop mixing as soon as the mixture starts to stick together.
- Take care not to overprocess.
- When adding almond essence or flavouring to mixtures avoid contact with the plastic as this may result in permanent marking.

**B to use the slicing/shredding disc**

- Never remove the cover until the cutting disc has completely stopped.
  - Handle the cutting disc with care as it is extremely sharp.
- 1 Place the non-slip base onto the bottom of the bowl.
  - 2 Place the drive shaft over the pin in the bowl ⑥.
  - 3 Holding by the centre grip, place the disc onto the drive shaft with the appropriate side uppermost ⑦.
  - 4 Fit the cover and push down to lock in place ⑧.
  - 5 Fit the power handle and push to lock in place. The power handle can be fitted with the ON/OFF button either facing inwards or outwards.
  - 6 Choose which size feed tube you want to use. The pusher contains a smaller feed tube for processing individual items or thin ingredients.  
To use the smaller feed tube - first put the large pusher inside the feed tube.  
To use the large feed tube - use both pushers together.
  - 7 Put the food in the feed tube.

- 8 Select a speed, switch on and push down evenly with the pusher – **never put your fingers in the feed tube.**
- 9 After use, unplug and dismantle. To remove the lid pull both locking clips out together and lift ⑨.

**hints**

- Use the shredding side for carrots, potatoes and foods of a similar texture.
- Use the slicing side for food items such as carrots, potatoes, cabbage, cucumber, courgette and onions.
- Use fresh ingredients.
- Don't cut food too small. Fill the width of the feed tube fairly full. This prevents the food from slipping sideways during processing. Alternatively use the small feed tube.
- Food placed upright comes out shorter than food placed horizontally.
- There will always be a small amount of waste left on the disc or in the bowl after processing.

processing guide				
Tool	Food	Max Qty	Recommended Speed	Approx Processing time (secs)
Knife Blade	Lean Meat	500g	5	10 – 30
	Herbs	30g	5	10
	Nuts	100g	5	20 – 30
	One Stage Cake	800g total wt	4 – 5	10 – 20
	Shortcrust Pastry	340g flour wt	5	20
Disc	Firm food such as carrots or potatoes	-	5	-
	Softer items such as cucumbers or tomatoes	-	3	-

### **C to use the whisk**

- You can whip light ingredients such as egg whites; cream; instant desserts; and eggs and sugar for whisked sponges.
  - Don't whisk heavier mixtures such as margarine and sugar - you'll damage the whisk.
- 1 Push the wire whisk into the whisk collar **10**.
  - 2 Fit the power handle inside the whisk collar. Push to lock.
  - 3 Place your food in a bowl.
  - Don't whisk more than 4 egg whites or 400ml (¾pt) cream.
  - 4 Plug in. To avoid splashing, start on speed 1. Move the whisk clockwise.
  - Don't let liquid get above the whisk wires.
  - 5 After use, unplug and dismantle.

### **D frother**

- Never add ingredients whilst the appliance is operating.
  - Take care when blending hot liquids.
  - Do not process more than 200mls milk as it may overflow as it froths and thickens.
- 1 Fit the frother shaft to the power handle **11** – push to lock.
  - 2 Start mixing on a low speed and increase the speed if required.

#### **hints**

- Always add the liquid ingredients first.
- Always mash fruit to a smooth puree before adding.
- If using syrups and powder mixes add them just before mixing to prevent them from sinking to the bottom.
- For best results, all liquid ingredients should be as cold as possible.
- Milk drinks will taste better if the milk is ice cold. The colder the milk, the thicker and more frothy the drink. Skimmed milk will produce a frothier drink than semi-skimmed or full fat milk.
- Never try to mix frozen fruit or crush ice.
- Break up large lumps of ice cream before frothing.

### **Optional attachment (not supplied in pack)**

Mini chopper - refer to "service and customer care" section to order.

#### **storage unit**

- Store all the attachments on the storage unit supplied **7** when not in use.

## care and cleaning

- Always switch off and unplug before cleaning.
- Don't touch the sharp blades.
- Take special care when preparing food for babies, the elderly and infirm. Always ensure that the hand blender shaft is thoroughly sterilised. Use a sterilising solution in accordance with the sterilising solution manufacturers instructions.
- Some foods, eg carrot, may discolour the plastic. Rubbing with a cloth dipped in vegetable oil helps remove discolouring.

#### **power handle + food processor cover**

- Wipe with a slightly damp cloth, then dry.
- Never immerse in water or use abrasives.

#### **blender shaft**

- Wash the blades under running water, then dry thoroughly
- Do not dishwash.

#### **shaft, knife blade, whisk, bowl, frother, base and storage unit**

- Wash up, then dry
- **Dishwashing is not recommended.**

## service and customer care

- If the cord is damaged it must, for safety reasons, be replaced by Kenwood or an authorised Kenwood repairer.

### **UK**

If you need help with:

- using your hand blender or
  - servicing or repairs (in or out of guarantee)
- ☎ call Kenwood on **023 9239 2333** and ask for Customer Care. **Have your model number ready** - it's on the power handle.

### ● **spares and attachments**

☎ call 0870 2413653.

### **other countries**

- Contact the shop where you bought your hand blender.

### **guarantee - UK only**

If your hand blender goes wrong within one year from the date you bought it, we will repair it (or replace it if necessary) free of charge provided:

- you have not misused, neglected or damaged it;
- it has not been modified (unless by Kenwood);
- it is not second-hand;
- it has not been used commercially;
- you have not fitted a plug incorrectly; and
- **you supply your receipt to show when you bought it.**

This guarantee does not affect your statutory rights.







Kenwood Limited, New Lane, Havant, Hampshire PO9 2NH, UK  
[www.kenwoodworld.com](http://www.kenwoodworld.com)

## Free Manuals Download Website

<http://myh66.com>

<http://usermanuals.us>

<http://www.somanuals.com>

<http://www.4manuals.cc>

<http://www.manual-lib.com>

<http://www.404manual.com>

<http://www.luxmanual.com>

<http://aubethermostatmanual.com>

Golf course search by state

<http://golfingnear.com>

Email search by domain

<http://emailbydomain.com>

Auto manuals search

<http://auto.somanuals.com>

TV manuals search

<http://tv.somanuals.com>