

instructions

Kenwood Chef and Major KM010 – KM020 series

Congratulations on buying a Kenwood. With such a wide range of attachments available, it's more than just a mixer. It's a state-of-the-art kitchen machine. We hope you'll enjoy it.

Robust. Reliable. Versatile. Kenwood.

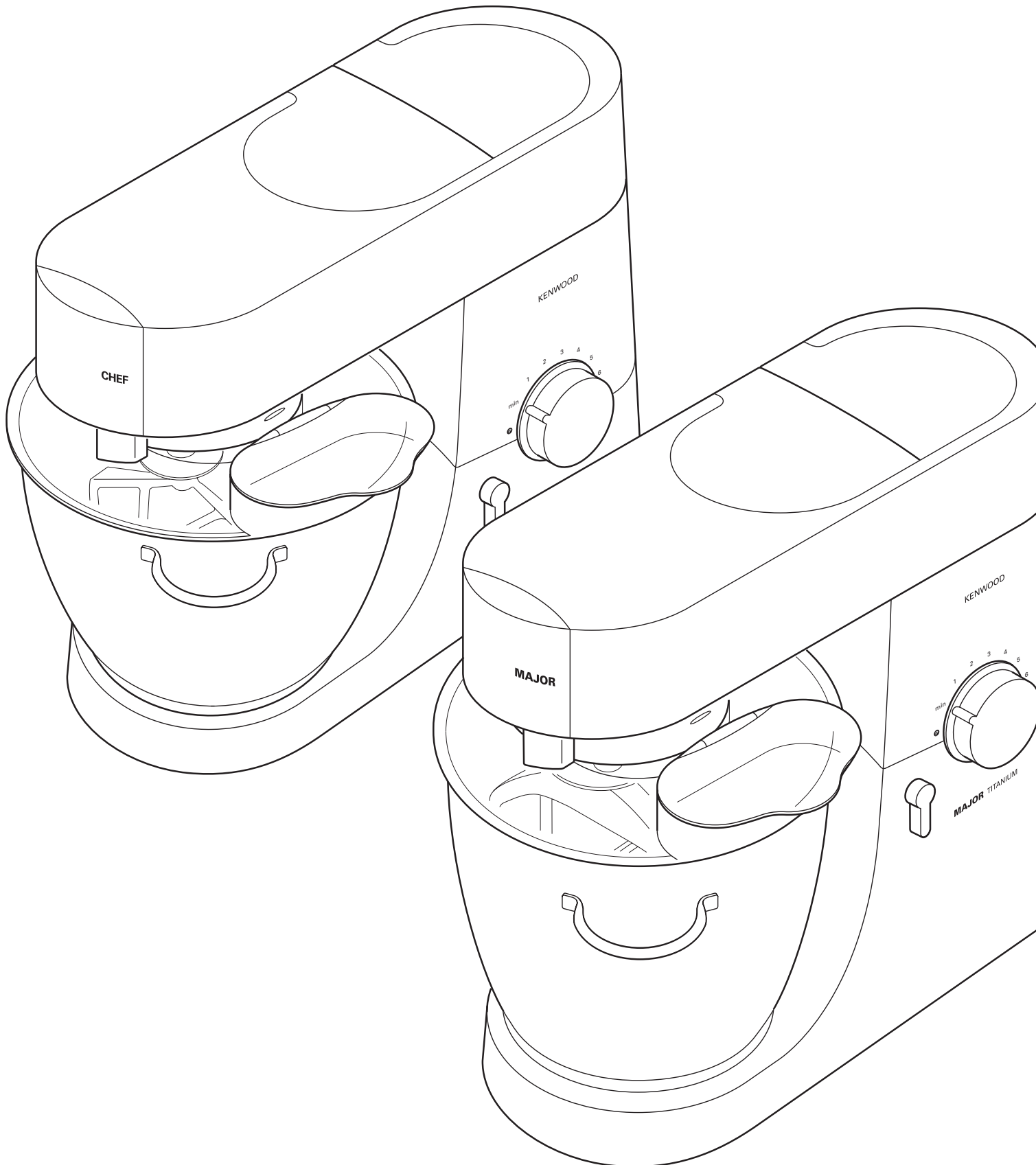

KENWOOD

know your Kenwood kitchen machine

before using your Kenwood appliance

- Read these instructions carefully and retain for future reference.
- Remove all packaging and any labels.

safety

- Switch off and unplug before fitting or removing tools/attachments, after use and before cleaning.
- Keep your fingers away from moving parts and fitted attachments.
- Never leave the machine on unattended.
- Never use a damaged machine. Get it checked or repaired: see 'service', page 7.
- Never operate the mixer with the head in the raised position.
- Never let the cord hang down where a child could grab it.
- Never let the power unit, cord or plug get wet.
- Never use an unauthorised attachment or more than one attachment at once.
- Never exceed the maximum capacities on page 3.
- When using an attachment, read the safety instructions that come with it.
- Take care when lifting this appliance as it is heavy. Ensure the head is locked and that the bowl, tools, outlet covers and cord are secure before lifting.
- This appliance is not intended for use by persons (including children) with reduced physical, sensory or mental capabilities, or lack of experience and knowledge, unless they have been given supervision or instruction concerning use of the appliance by a person responsible for their safety.
- Children should be supervised to ensure that they do not play with the appliance.
- Only use the appliance for its intended domestic use. Kenwood will not accept any liability if the appliance is subject to improper use, or failure to comply with these instructions.

before plugging in

important - UK only

- Make sure your electricity supply is the same as the one shown on the underside of your machine.
- The wires in the cord are coloured as follows:
Blue = Neutral, Brown = Live.
- The appliance must be protected by a 13A approved (BS1362) fuse.
- For non-rewireable plugs the fuse cover **MUST** be refitted when replacing the fuse. If the fuse cover is lost then the plug must not be used until a replacement can be obtained. The correct fuse cover is identified by colour and a replacement may be obtained from your Kenwood Authorised Repairer (see Service).
- If a non-rewireable plug is cut off it must be **DESTROYED IMMEDIATELY**. An electric shock hazard may arise if an unwanted non-rewireable plug is inadvertently inserted into a 13A socket outlet.
- This machine complies with European Economic Community Directive 89/336/EEC.

before using for the first time

- 1 Remove all packaging.
- 2 Wash the parts: see 'care and cleaning', page 7.
- 3 Push excess cord into the cord stowage compartment at the back of the machine.

know your Kenwood kitchen machine

know your Kenwood kitchen machine

- attachment outlets
- 1 high-speed outlet
 - 2 medium speed outlet
 - 3 slow-speed outlet
 - 4 tool socket
- the mixer
- 5 mixer head
 - 6 outlet catch
 - 7 bowl
 - 8 head-lift lever
 - 9 on/off and speed switch
 - 10 power unit
 - 11 K-beater
 - 12 whisk
 - 13 dough hook
 - 14 spatula
 - 15 splashguard

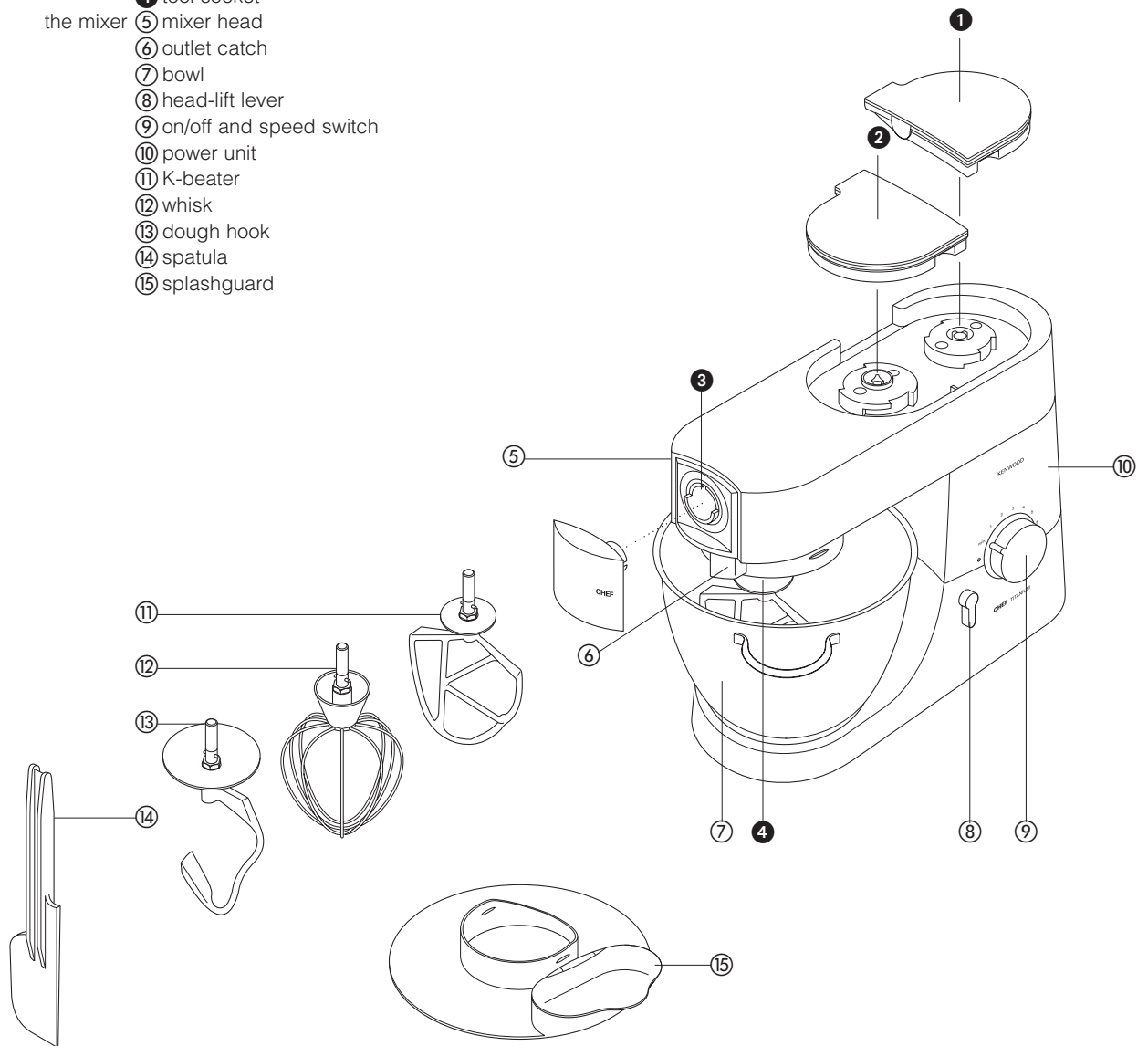

the mixer

the mixing tools and some of their uses

- K-beater • For making cakes, biscuits, pastry, icing, fillings, éclairs and mashed potato.
- whisk • For eggs, cream, batters, fatless sponges, meringues, cheesecakes, mousses, soufflés. Don't use the whisk for heavy mixtures (eg creaming fat and sugar) - you could damage it.
- dough hook • For yeast mixtures.

to use your mixer

- 1 Turn the head-lift lever clockwise ❶ and raise the mixer head till it locks.
- to insert a tool 2 Push up till it stops ❷ then turn.
- 3 Fit the bowl onto the base - press down and turn clockwise ❸
- 4 Turn the head-lift lever clockwise and lower the mixer head till it locks.
- 5 Switch on by turning the speed switch to the desired setting.
- Switch to pulse **P** for short bursts.
- to remove a tool 6 Turn and remove.

- hints
- Switch off and scrape the bowl with the spatula frequently.
 - Eggs at room temperature are best for whisking.
 - Before whisking egg whites, make sure there's no grease or egg yolk on the whisk or bowl.
 - Use cold ingredients for pastry unless your recipe says otherwise.

points for bread making

- important
- Never exceed the maximum capacities below - you'll overload the machine.
 - If you hear the machine labouring, switch off, remove half the dough and do each half separately.
 - The ingredients mix best if you put the liquid in first.

maximum capacities

CHEF

MAJOR

- | | | |
|--------------------------|-----------------------------------|--------------------------------|
| shortcrust pastry | • Flour weight: 680g - 1lb 8oz | Flour weight: 910g - 2lb |
| stiff yeast dough | • Flour weight: 1.36kg - 3lb | Flour weight: 1.5kg - 3lb 5oz |
| | • Total weight: 2.18kg - 4lb 13oz | Total weight: 2.4kg - 5lb 5oz |
| soft yeast dough | • Flour weight: 1.3kg - 2lb 14oz | Flour weight: 2.6kg - 5lb 12oz |
| | • Total weight: 2.5kg - 5lb 8oz | Total weight: 5kg - 11lb |
| fruit cake mix | • Total weight: 2.72kg - 6lb | Total weight: 4.55kg - 10lb |
| egg whites | • 12 | 16 |

speed switch ❹

- K-beater • **creaming fat and sugar** start on min, gradually increasing to 'max'.
- **beating eggs into creamed mixtures** 4 - 'max'.
- **folding in flour, fruit etc** Min - 1
- **all in one cakes** start on min speed, gradually increase to max.
- **rubbing fat into flour** min - 2.
- whisk • Gradually increase to 'max'.
- dough hook • Start on 'min', gradually increasing to 1.

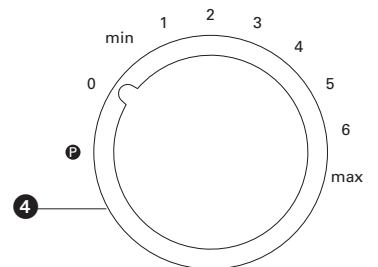
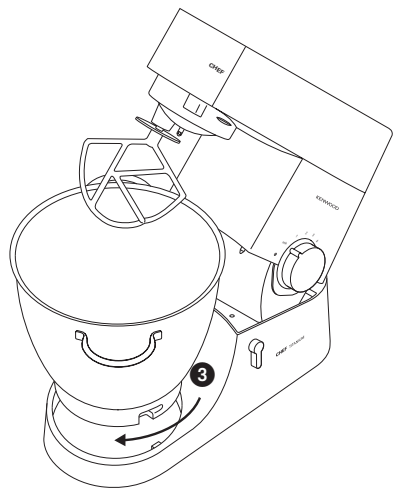
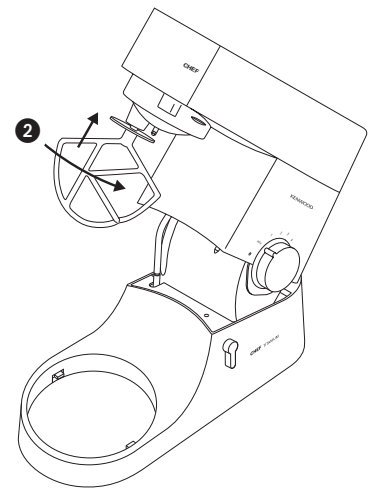
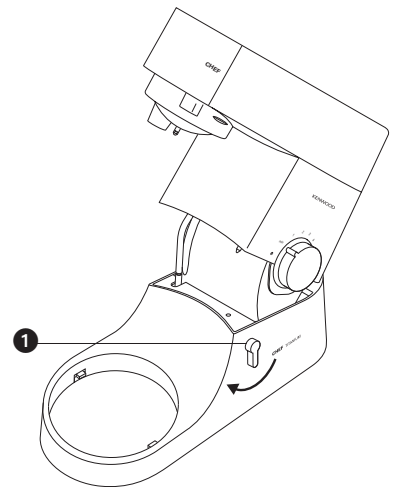

for **cleaning** see page 7

troubleshooting

problem

- The whisk or K-beater knocks against the bottom of the bowl or isn't reaching the ingredients in the bottom of the bowl.

solution • Adjust the height. Here's how:

- 1 Unplug.
- 2 Raise the mixer head and insert the whisk or beater.
- 3 Hold it, then loosen the nut **1**
- 4 Lower the mixer head.
- 5 Adjust the height by turning the shaft. Ideally the whisk/K-beater should be **almost** touching the bottom of the bowl **2**
- 6 Raise the head, hold the whisk/K-beater and tighten the nut.

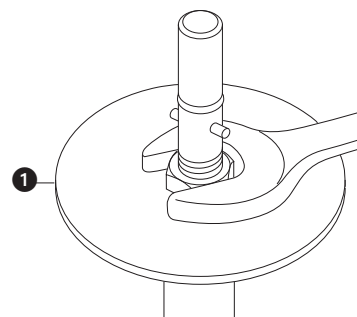

problem

- The mixer stops during operation.

solution • Your mixer is fitted with an overload protection device and will stop if overloaded to protect the machine. If this happens, switch off and unplug the mixer. Remove some of the ingredients to reduce the load, and allow the mixer to stand for a few minutes. Plug in and reselect the speed. If the mixer does not restart immediately allow to stand for additional time.

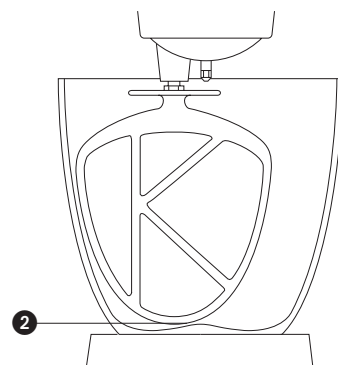

to fit and use your splashguard

- 1 Raise the mixer head until it locks.
- 2 Fit the bowl onto the base.
- 3 Push the splashguard onto the underside of the mixer head **3** until fully located. The hinged section should be positioned as shown.
- 4 Insert required tool.
- 5 Lower the mixer head.
- During mixing, ingredients can be added directly to the bowl via the hinged section of the splashguard **4**.
- You do not need to remove the splashguard to change tools.
- 6 Remove the splashguard by raising the mixer head and sliding it down.

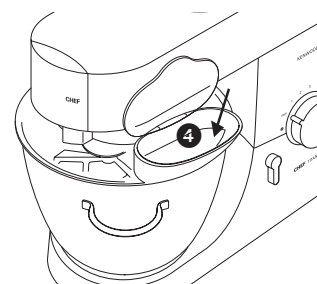
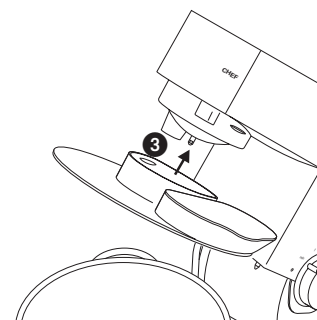

the **attachments** available

To buy an attachment not included in your pack, call your KENWOOD repairer.

attachment attachment code

- flat pasta maker** ① **AT970A**
- additional pasta attachments (not shown) used in conjunction with AT970A
 - AT971A** tagliatelle
 - AT972A** tagliolini
 - AT973A** trenette
 - AT974A** spaghetti
- pasta maker** ② **AT910** comes with maccheroni rigati die (12 optional dies plus biscuit maker can be fitted)
- roto food cutter** ③ **AT948A** comes with 4 drums
- multi food grinder** ④ **AT950A** comes with
 - a large sausage nozzle
 - b small sausage nozzle
 - c kebbe maker
- grain mill** ⑤ **AT941A**
- citrus juicer** ⑥ **AT312**
- food processing attachment** ⑦ **AT640** includes 3 cutting plates as standard and a knife blade
- pro slicer/grater** ⑧ **AT998A** includes 3 cutting plates as standard
 - optional plates for AT998A
 - a extra coarse shredder **part number 639021**
 - b rasping plate **part number 639150**
 - c standard chipper **part number 639083**
- liquidiser** ⑨ 1.5 l acrylic **AT337**, 1.5 l glass **AT338**
- multi-mill** ⑩ **AT320** comes with 4 glass jars and 4 lids for storage
- non-stop centrifugal juicer** ⑪ **AT935A**
- ice-cream maker** ⑫ CHEF **AT956**, MAJOR **AT957**
- potato prep attachment** ⑬ CHEF **AT934A**, MAJOR **AT952A**
- colander and sieve** ⑭ CHEF **AT992A**, MAJOR **AT930A**
- stainless steel bowls** ⑮ brushed: CHEF **343270**, MAJOR **343268**
- splashguard** ⑯ CHEF & MAJOR **693766**
- flexible beater** ⑰ CHEF **AW44001**, MAJOR **AW44002**
- cover** ⑱ CHEF, **533722**, MAJOR **606397**

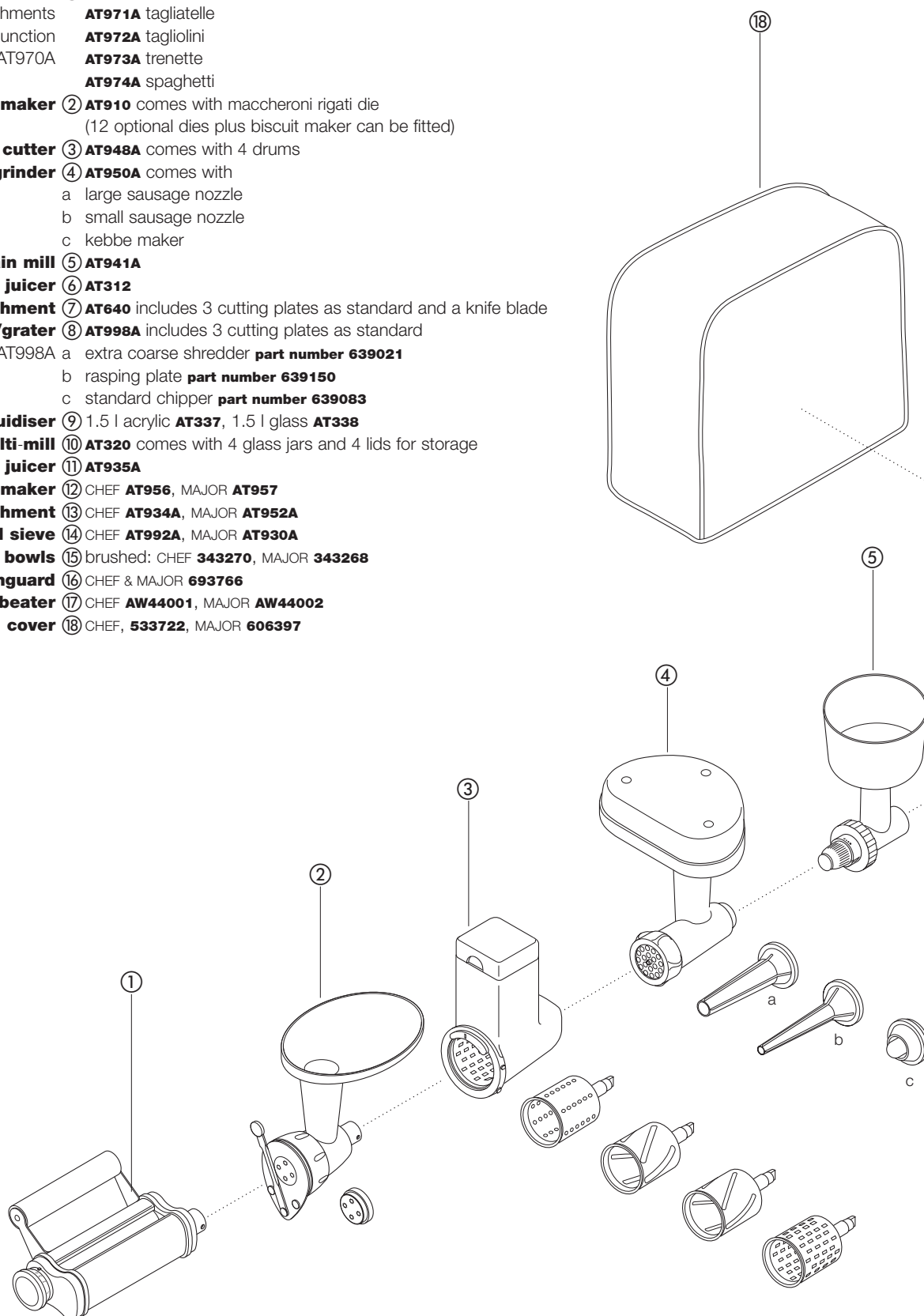

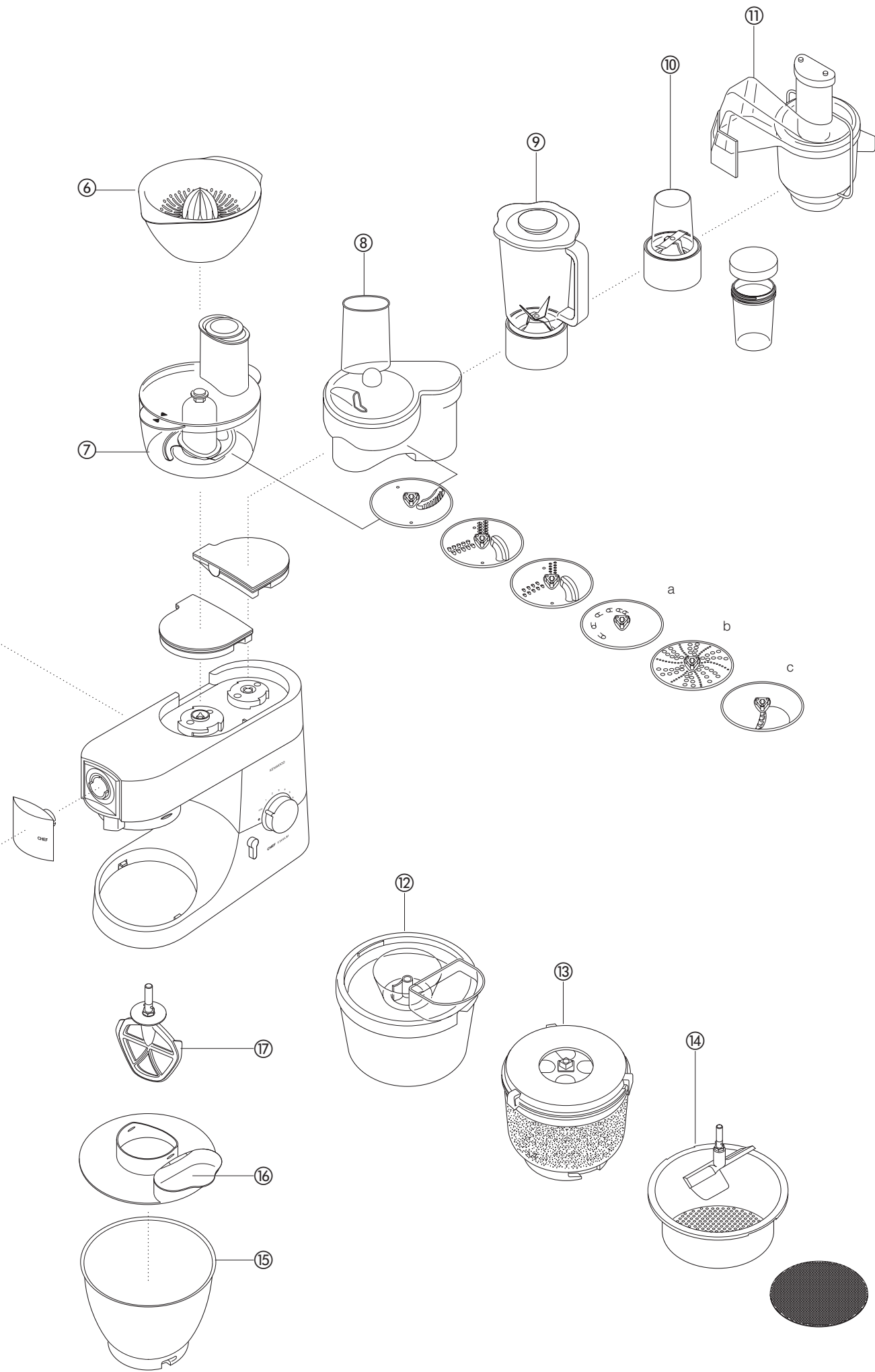

cleaning and service

care and cleaning

- Always switch off and unplug before cleaning.
- A little grease may appear at **outlet 2** when you first use it. This is normal - just wipe it off.

- power unit, outlet covers
- Wipe with a damp cloth, then dry.
 - Never use abrasives or immerse in water.
- bowl
- Wash by hand, then dry thoroughly or wash in the dishwasher.
 - Never use a wire brush, steel wool or bleach to clean your stainless steel bowl. Use vinegar to remove limescale.
 - Keep away from heat (cooker tops, ovens, microwaves).
- tools
- Stainless steel tools can be washed by hand or in a dishwasher.
 - Non stainless steel tools (coated) should only be washed by hand, then dried thoroughly.
- splashguard
- Wash by hand, then dry thoroughly.

service and customer care

- If the cord is damaged it must, for safety reasons, be replaced by KENWOOD or an authorised KENWOOD repairer.

UK If you need help with:

- using your machine
 - servicing or repairs (in or out of guarantee)
- ☎ call KENWOOD Customer Care on **023 9239 2333**.

Have your model number ready - it's on the underside of the mixer.

- spares and attachments

☎ call **0870 2413653**.

- other countries
- Contact the shop where you bought your machine.

guarantee UK only

- If your machine goes wrong within one year from the date you bought it, we will repair or replace it free of charge provided:
 - you have not misused, neglected or damaged it;
 - it has not been modified;
 - it is not second-hand;
 - it has not been used commercially;
 - you have not fitted a plug incorrectly; and
- **you supply your receipt to show when you bought it.**

This guarantee does not affect your statutory rights.

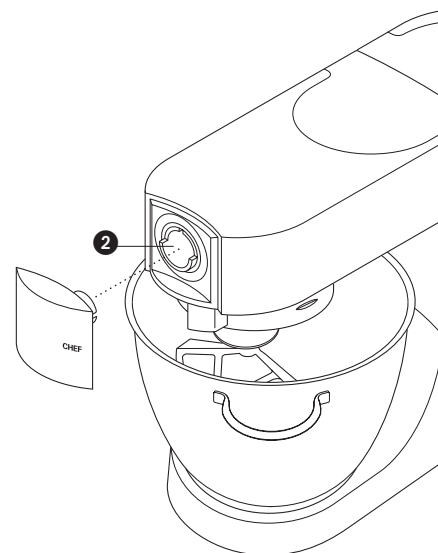

recipes

See important points for bread making on page 3.

white bread *stiff British-type dough*

- ingredients
- 1.36kg (3lb) strong plain flour
 - 15ml (3tsp) salt
 - 25g (1oz) fresh yeast; or 15g/20ml (½oz) dried yeast + 5ml (1tsp) sugar
 - 750ml (1¼pts) warm water: 43°C (110°F). Use a thermometer or add 250ml (9floz) boiling water to 500ml (18floz) cold water
 - 25g (1oz) lard
- method
- 1 **dried yeast** (the type that needs reconstituting): pour the warm water into the bowl. Then add the yeast and the sugar and leave to stand for about 10 minutes until frothy.
fresh yeast: crumble into the flour.
other types of yeast: follow the manufacturer's instructions.
 - 2 Pour the liquid into the bowl. Then add the flour (with fresh yeast if used), salt and lard.
 - 3 Knead at minimum speed for 45 - 60 seconds. Then increase to speed 1, adding more flour if necessary, until a dough has formed.
 - 4 Knead for 3 - 4 more minutes at speed 1 until the dough is smooth, elastic and leaves the sides of the bowl clean.
 - 5 Put the dough into a greased polythene bag or a bowl covered with a tea towel. Then leave somewhere warm until doubled in size.
 - 6 Re-knead for 2 minutes at speed 1.
 - 7 Half fill four 450g (1lb) greased tins with the dough, or shape it into rolls. Then cover with a tea towel and leave somewhere warm until doubled in size.
 - 8 Bake at 230°C/450°F/Gas Mark 8 for 30 - 35 minutes *for loaves* or 10 - 15 minutes *for rolls*.
 - When ready, the bread should sound hollow when tapped on the base.

shortcrust pastry

- ingredients
- 450g (1lb) flour, sieved with the salt
 - 5ml (1tsp) salt
 - 225g (8oz) fat (mix lard and margarine straight from the fridge)
 - About 80ml (4tbsp) water
- hint
- Don't overmix
- method
- 1 Put the flour into the bowl. Chop the fat up roughly and add to the flour.
 - 2 Mix at speed 1 until it resembles breadcrumbs. Stop before it looks greasy.
 - 3 Add the water and mix at minimum speed. Stop as soon as the water is incorporated.
 - 4 Cook at around 200°C/400°F/Gas Mark 6, depending on the filling.

pavlova

- ingredients
- 3 large egg whites
 - 175g (6oz) caster sugar
 - 275ml (10 fl.oz.) double cream
 - fresh fruit eg raspberries, strawberries, grapes, kiwi fruit
- method
- 1 Whisk the egg whites on a high speed until they form 'soft peaks'.
 - 2 With the whisk operating on speed 5, gradually add the sugar one tablespoon at a time, whisking after each addition.
 - 3 Line a baking tray with silicone paper, then spoon the meringue onto the paper forming a nest approximately 20cm/8" in diameter.
 - 4 Place the baking tray into an oven preheated to 150°C/300°F/Gas Mark 2, then immediately reduce the temperature to 140°C/275°F/Gas Mark 1 and bake for 1 hour. Turn the heat off but leave the pavlova in the oven to cool down.
 - 5 When ready to serve, peel off the silicone paper and place on a serving dish. Whip the cream until soft peaks form then spread over the top of the pavlova and decorate with the fruit.

recipes *continued*

scrumptious chocolate cake

- ingredients
- 225g (8oz) butter, softened
 - 250g (9oz) caster sugar
 - 4 eggs
 - 5ml (1tsp) instant coffee dissolved in 15ml (1tbsp) hot water
 - 30ml (2tbsp) milk
 - 5ml (1tsp) almond essence
 - 50g (2oz) ground almonds
 - 100g (4oz) self raising flour
 - 5ml (1tsp) baking powder
 - 50g (2oz) unsweetened cocoa powder
- method
- 1 Cream the butter and sugar on a low speed gradually increasing to a higher speed until the mixture is light and fluffy. Scrape down the bowl and beater.
 - 2 Beat the eggs in a jug and whilst the mixer is operating on a high speed, gradually add the egg a little at a time until incorporated. Switch off and scrape down.
 - 3 Incorporate the dissolved coffee, milk and almond essence on a low speed. Add the ground almonds, sieved flour, baking powder and cocoa. Mix on a low speed to incorporate.
 - 4 Divide the mixture between two 20cm/8" cakes tins that have been lined with greased greaseproof paper. Level the tops then bake at 180°C/350°F/Gas Mark 4 for approximately 30 minutes until springy to the touch.
 - 5 Turn out and cool on a wire rack.

chocolate mousseline filling

- ingredients
- 275g (10oz) plain chocolate, broken into pieces
 - 225ml (8 fl.oz.) double cream
- method
- 1 Melt the chocolate by placing in a bowl over a pan of barely simmering water.
 - 2 Whisk the cream starting on a low speed gradually increasing to a higher speed until it forms soft peaks.
 - 3 When the chocolate has melted remove the bowl from the heat and, using a large spoon fold into the cream.
 - 4 Spread the chocolate filling between the cooled cakes.

honey and nut spread using the liquidiser

- ingredients
- 25g chopped nuts
 - 875g clear honey at room temperature
- method
- 1 Place the ingredients into the liquidiser in the above order.
 - 2 Blend together using the pulse control for 5 seconds
 - 3 Use as required.

Kenwood Limited, New Lane, Havant, Hampshire PO9 2NH, UK
www.kenwoodworld.com



Free Manuals Download Website

<http://myh66.com>

<http://usermanuals.us>

<http://www.somanuals.com>

<http://www.4manuals.cc>

<http://www.manual-lib.com>

<http://www.404manual.com>

<http://www.luxmanual.com>

<http://aubethermostatmanual.com>

Golf course search by state

<http://golfingnear.com>

Email search by domain

<http://emailbydomain.com>

Auto manuals search

<http://auto.somanuals.com>

TV manuals search

<http://tv.somanuals.com>