

\*\* Refer to page 2 if you want to know system configuration.

\* Refer to parts list on page 28.

In compliance with Federal Regulations, following are reproduction of labels on, or inside the product relating to laser product safety.

KENWOOD-Corp. certifies this equipment conforms to DHHS Regulations No.21 CFR 1040. 10, Chapter 1, subchapter J.

**DANGER : Laser radiation when open and interlock defeated. AVOID DIRECT EXPOSURE TO BEAM.**



# RXD-V555/V757

## CONTENTS / ACCESSORIES

### Contents

CONTENTS / ACCESSORIES .....	2	SCHEMATIC DIAGRAM .....	16
EXTERNAL VIEW .....	3	EXPLODED VIEW .....	26
ADJUSTMENT .....	7	PARTS LIST.....	28
PC BOARD .....	8	SPECIFICATIONS .....	Back cover

### Accessories

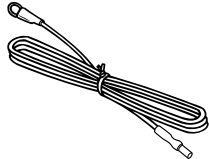
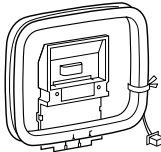
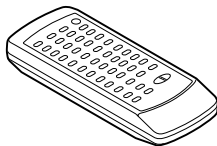
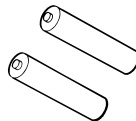
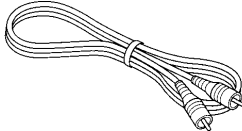
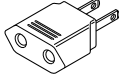
<p>FM Antenna(1) (T90-0883-08)</p>	<p>AM Loop Antenna(1) (T90-0879-08)</p>	<p>Remote Control(1) (A70-1574-08)</p>	<p>"AA" size battery(2) (UM/SUM-3, R6, HP-7 or similar)</p>
			
<p>Video Cable(1) (E30-7255-08)</p>	<p>AC Plug Adaptor (1) (E03-0115-05)</p>		<p>Use to adapt the plug on the power cord to the shape of the wall outlet. (Accessory only for regions where use is necessary.)</p>
			

### System Configurations

SYSTEM	MAIN UNIT	DESTINATION	SPEAKER
XD-V858	RXD-V757	MI	LS-N90VS
XD-V757	RXD-V757	MI	LS-N70VS
XD-V555	RXD-V555	MI	LS-N50VS
XD-V555-H	RXD-V555-H	M	LS-N50VS-H

### Cautions

**The marking of products using lasers  
(Except for some areas)**



The marking is located on the rear panel and says this product has been classified as Class 1. It means that there is no danger of hazardous radiation outside the product

# RXD-V555/V757

## EXTERNAL VIEW

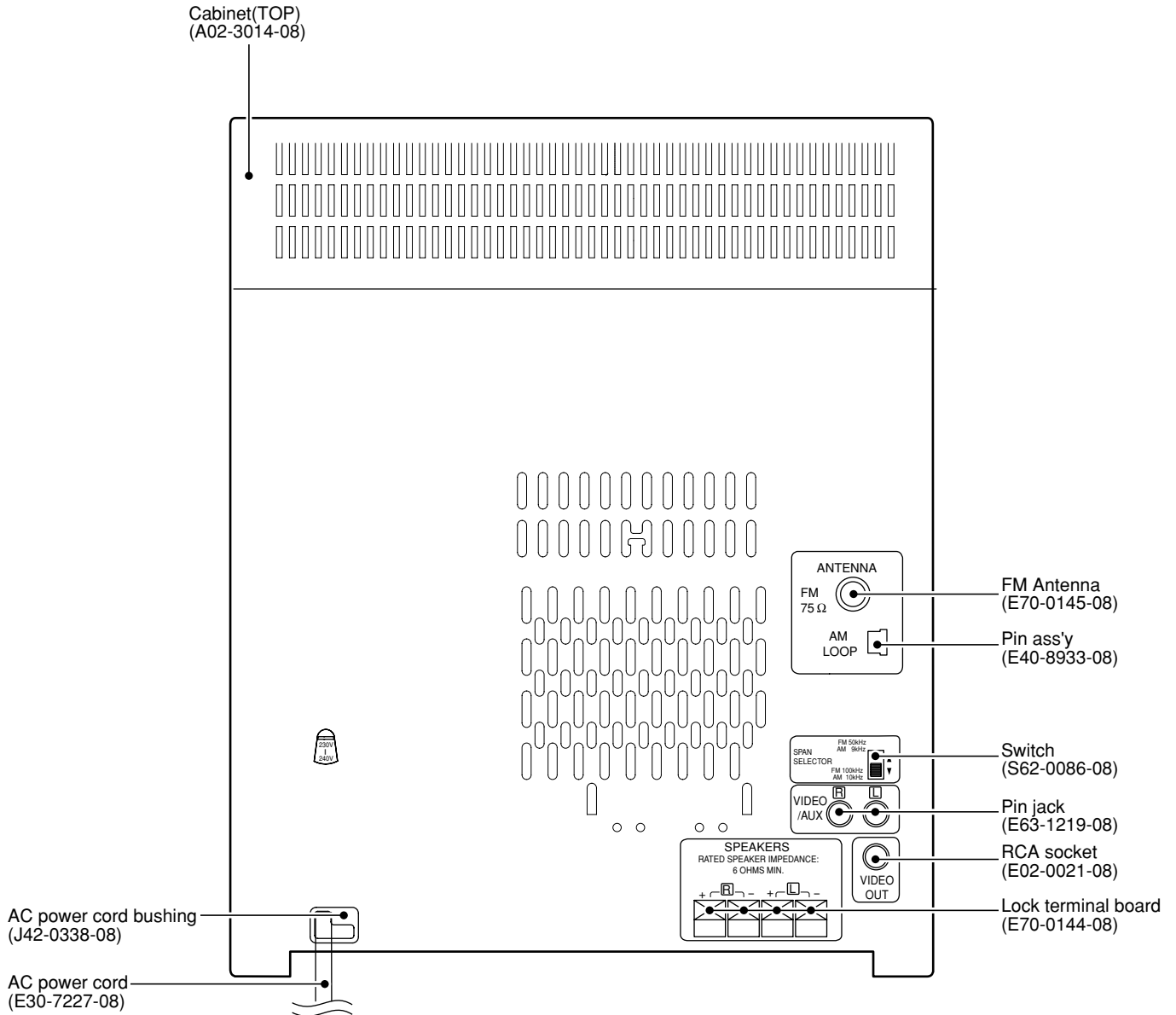

# RXD-V252/V252-H

## CIRCUIT DESCRIPTION

### Port Function of MPEG1 Video/Audio Processing : ES3880 (ICM2)

Port No.	Port Name	I/O	Function
1,31,51	VCC3	-	Supply voltage for 3.3V.
2	RAS#	O	DRAM row address strobe (active low).
3	DWE#	O	DRAM write enable (active low).
4~12	MA(0~8)	O	DRAM multiplexed row and column address bus.
13~28	DBUS(0~15)	I/O	DRAM data bus.
29	RESET#	I	System reset (active low).
30,50,80,100	GND	-	Ground.
32~39	YUV(0~7)	O	Y is luminance, UV are chrominance data bus for screen video interface. YUV(0~7) for 8 bit YUV mode.
40	VSYNC	I/O	Vertical sync for screen video interface, programmable for rising or falling edge.
41	HSYNC	I/O	Horizontal sync for screen video interface, programmable for rising or falling edge.
42	CPUCLK	I	RISC and system clock input.
43	PCLK2X	I/O	Pixel clock: two times the actual pixel clock for screen video interface.
44	PCLK	I/O	Pixel clock qualifier in for screen video interface.
45~49,52,53,54	AUX(0~7)	I/O	Auxiliary control pins (AUX0 and AUX1 are open collectors).
55~62	LD(0~7)	I/O	RISC interface data bus.
63	LWR#	O	Unused.
64	LOE#	O	RISC interface output enable (active low).
65,66,67	LCS(3,1,0)#	O	RISC interface chip select (active low).
68~79,82~87	LA(0~17)	O	RISC interface address bus.
81	VCC	-	Digital supply voltage for 5.0V.
88	ACLK	I/O	Master clock for external audio DAC(8.192MHz, 11.2896MHz, 12.288MHz, 16.9344MHz, and 18.432MHz).
89	AOUT/SEL/PLL0	O	Dual-purpose pin. AOUT is the audio interface serial data output.
		I	Pins SEL -PLL(1: 0) select phase-lock loop(PLL) clock frequency CPUCLK for the Visba : 00 = bypass PLL 01 = 54MHz PLL 10 = 67.5MHz PLL 11 = 81MHz PLL
90	ATCLK	I/O	Audio transmit bit clock.
91	ATFS/SEL/PLL1	O	Dual-purpose pin. ATFS is the audio interface transmit frame sync.
		I	Pins SEL -PLL(1: 0) select phase-lock loop(PLL) clock frequency CPUCLK for the Visba. See the SEL -PLL0 pin above for the settings.
92	DOE	O	Dual-purpose pin. DRAM output enable (active low)/DRAM multiplexed row and column address bus.
93	AIN	I	Audio interface serial data input.
94	ARCLK	I	Audio receive bit clock.
95	ARFS	I	Audio interface receive frame sync.
96	TDMCLK	I	TDM interface serial clock.
97	TDMDR	I	TDM interface serial data receive.
98	TDMFS	I	TDM interface frame sync.
99	CAS#	O	DRAM column address strobe bank 0 (active low).

Block Diagram for MPEG1 Video/Audio Processing

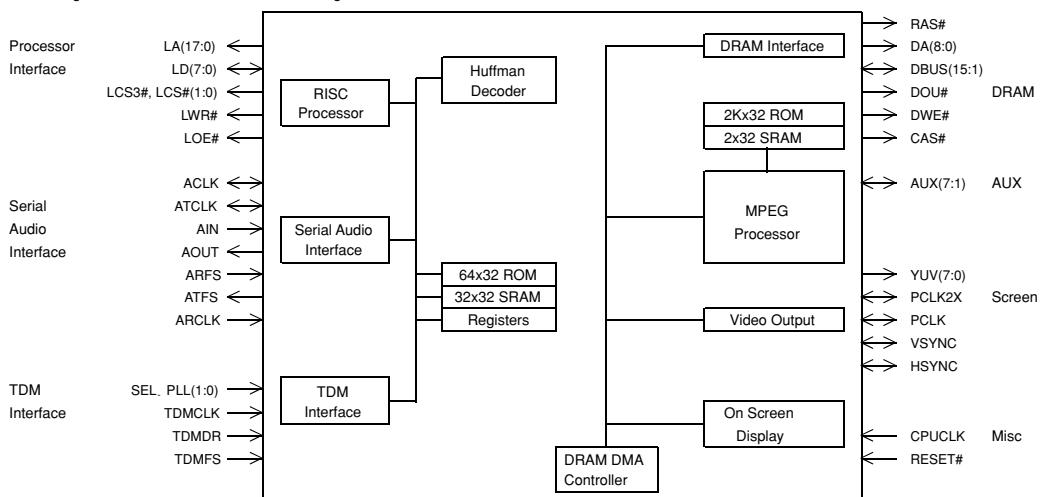

# RXD-V252/V252-H

## CIRCUIT DESCRIPTION

### Port Function of DAC & TV Encoder : ES3889 (ICM3)

Port No.	Port Name	I/O	Function
1,25,26,31,72 75,77,91,100	VSS	I	Ground.
5,16,32,66 73, 78,90	VCC	I	Supply voltage for 5.0v.
6	DSC C	I	Clock for programming to access internal registers.
7	AUX0	I/O	Unused.
9	AUX1	I/O	Servo reverse or control pin.
11	AUX2	I/O	Servo LD ON or control pin.
70	AUX3	I/O	Unused.
69	AUX4	I/O	Servo CCW/Close or control pin.
68	AUX5	I/O	Unused.
67	AUX6	I/O	Servo XLAT or control pin/VFD DO.
14	AUX7	I/O	Servo BRKM/Sense or control pin/VFD DI.
18	AUX8	I/O	Servo Mute/Open or control pin/VFD CLK.
20	AUX9	I/O	Servo SQS0 or control pin.
34	AUX10	I/O	Unused.
35	AUX11	I/O	Unused.
36	AUX12	I/O	Unused.
38	AUX13	I/O	Serial interrupt/CD Mute or control pin.
39	AUX14	I/O	Unused.
40	AUX15	I/O	Unused.
8,81,83,85 93,95,97,99	DSC D(7~0)	I/O	Data for programming to access internal registers.
10	DSC S	I	Strobe for programming to access internal registers.
12	DCLK	O	Dual purpose pin. DCLK is the MPEG decoder clock.
	EXT CLK	I	EXT CLK is the external clock EXT CLK is an input during bypass PLL mode.
13	RESET B	I	Video reset (active low).
15	MUTE	O	Audio mute.
17	MCLK	I	Audio master clock.
19	TWS	I	Dual purpose pin. TWS is the transmit audio frame sync.
	SPLL OUT	O	SPLL OUT is the select PLL output.
21	TSD	I	Transmit audio data input.
22	TBCK	I	Transmit audio bit clock.
23	RWS SEL PLL1	O	Dual purpose pin. RWS is the receive audio frame sync.
		I	Pins SEL PLL (1,0) select the PLL clock frequency for the DCLK output.
			SEL PLL1    SEL PLL0                    DCLK
			0            0                    Bypass PLL (input mode)
			0            1                    27MHz (output mode)
	1            0                    32.4MHz (output mode)		
	1            1                    40.5MHz (output mode)		
24	RSTOUT B	O	Reset output (active low).
2~4,27~30 76	NC	-	Unused.
33	RSD	O	Dual purpose pin. RSD is the receive audio data input.
	SEL PLL0	I	SEL PLL0 along with SEL PLL1 select the PLL clock frequency for the DCLK output.
37	RBCK	O	Dual purpose pin. RBCK is the receive audio bit clock.
	SER IN	I	SER IN is the serial input DSC mode.
41,51	AGND	I	Audio analog ground.
42	VCM	I	ADC common mode reference (CMR) buffer output.
43	VREFP	I	DAC and ADC maximum reference.
44	VCCAA	I	Analog VCC(5V).
45,46	AOR+, AOR-	O	Right channel output.
47,48	AOL-, AOL+	O	Left channel output.
49	MIC1	I	Microphone input 1.
50	MIC2	I	Microphone input 2.

# RXD-V252/V252-H

## CIRCUIT DESCRIPTION

Port No.	Port Name	I/O	Function
52	VREF	I	Internal resistor divider generators common mode reference(CMR) voltage.
53	VREFM	I	DAC and ADC minimum reference.
54	RSET	I	Full scale DAC current adjustment.
55	COMP	I	Compensation pin.
56,57,62,63	VGND	I	Video analog ground.
58	CDAC	O	Modulated chrominance output.
59,60	VVDD	I	Video VCC(5V).
61	YDAC	O	Y luminance data bus for screen video port.
64	VDAC	O	Composite video output.
65	ACAP	I	Audio CAP.
71	XOUT	O	Crystal output.
74	XIN	I	27MHz crystal input.
79	PCLK	I/O	13.5MHz pixel clock.
80	2XPCLK	I/O	27MHz (2 times pixel clock).
82	HSYN B	O	Horizontal sync (active low).
84	VSYN B	O	Vertical sync (active low).
86~89,92 94,96,98	YUV(7~0)	I	YUV data bus for screen video port.

Block Diagram for DAC & TV Encoder : ES3889 (ICM3)

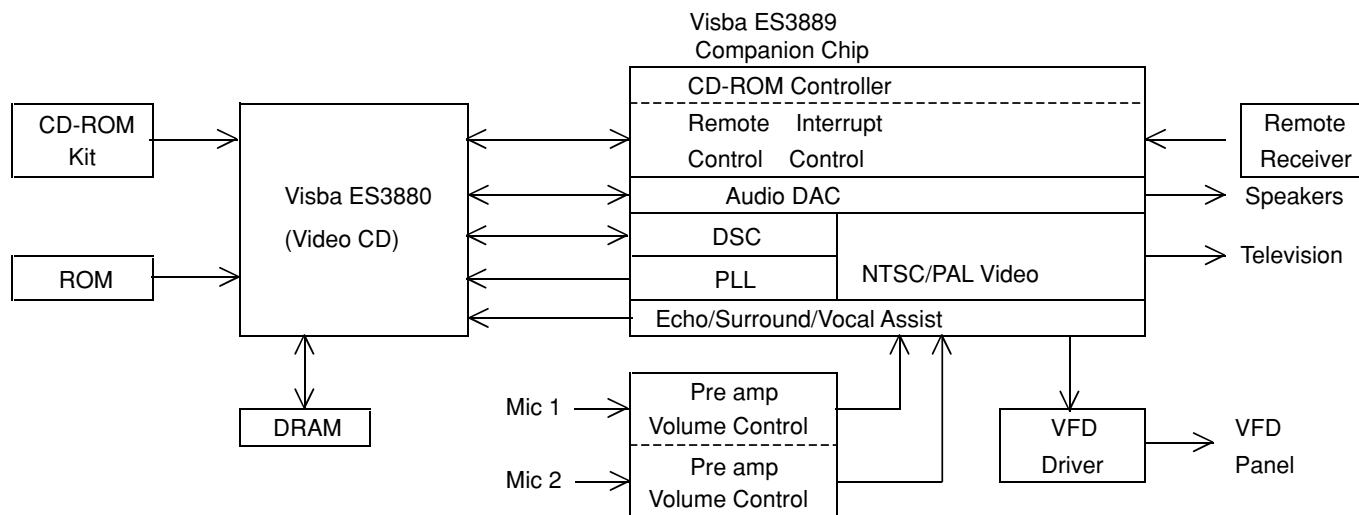

# RXD-V555/V757

## ADJUSTMENT

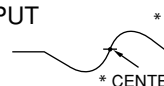
NO.	CHECKING ITEM	SG 'N' SET FREQ		ADJ POINT	SPEC	REMARKS
1.	FM FREQ COVERAGE	FL	87.5MHz	T301 (TP301)	1.3V ± 0.1V	ADJUST UNTIL VOLTAGE IS WITHIN GIVEN SPEC
		FH	108.0MHz	(TP301)	7.8V ± 0.8V	CONFIRM VOLTAGE IS WITHIN GIVEN SPEC.
2.	FM IF	-	10.7MHz	T302 (TP302)	-	ADJUST COIL T302 UNTIL MAX. OUTPUT  <p>* CFM GOOD AND MAX 'S' CURVE IS OBTAINED.            * CENTER FREQ. MARKER 10.7MHz</p>
3.	FM FREQ. TRACKING	-	98MHz	L312 (TP302)	-	ADJUST L312 UNTIL MAXIMUM WAVEFORM APPEAR.

### CONDITION : AM MOD 30% DEV 400Hz

NO.	CHECKING ITEM	SG 'N' SET FREQ		ADJ POINT	DC VOLTAGE SPEC	REMARKS
1.	AM FREQ COVERAGE	FL	531KHz	T306 (TP301)	1.1V ± 0.1V	ADJUST UNTIL VOLTAGE IS WITHIN GIVEN SPEC.
		FH	1602KHz	(TP301)	8.8V ± 0.5V	CONFIRM VOLTAGE IS WITHIN GIVEN SPEC
2.	AM IF	FL	990KHz (50dB)	T351 (TP302)	-	SP OUTPUT → ADJ T351 UNTIL MAX POINT FROM AC VOLTMETER
3.	AM FREQ. TRACKING	FL	990KHz (50dB)	(TP302)	-	CONFIRM MAX. OUTPUT.

### Adjustment Parts Configuration

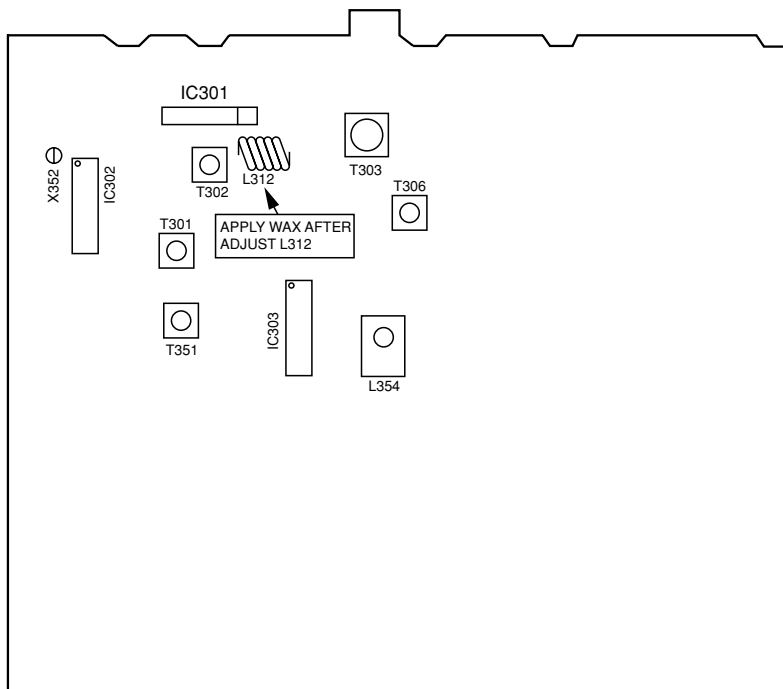

### ANT DUMMY CIRCUIT FOR FM

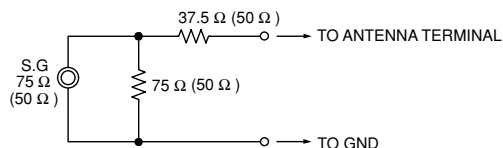

# PC BOARD (Component side view)

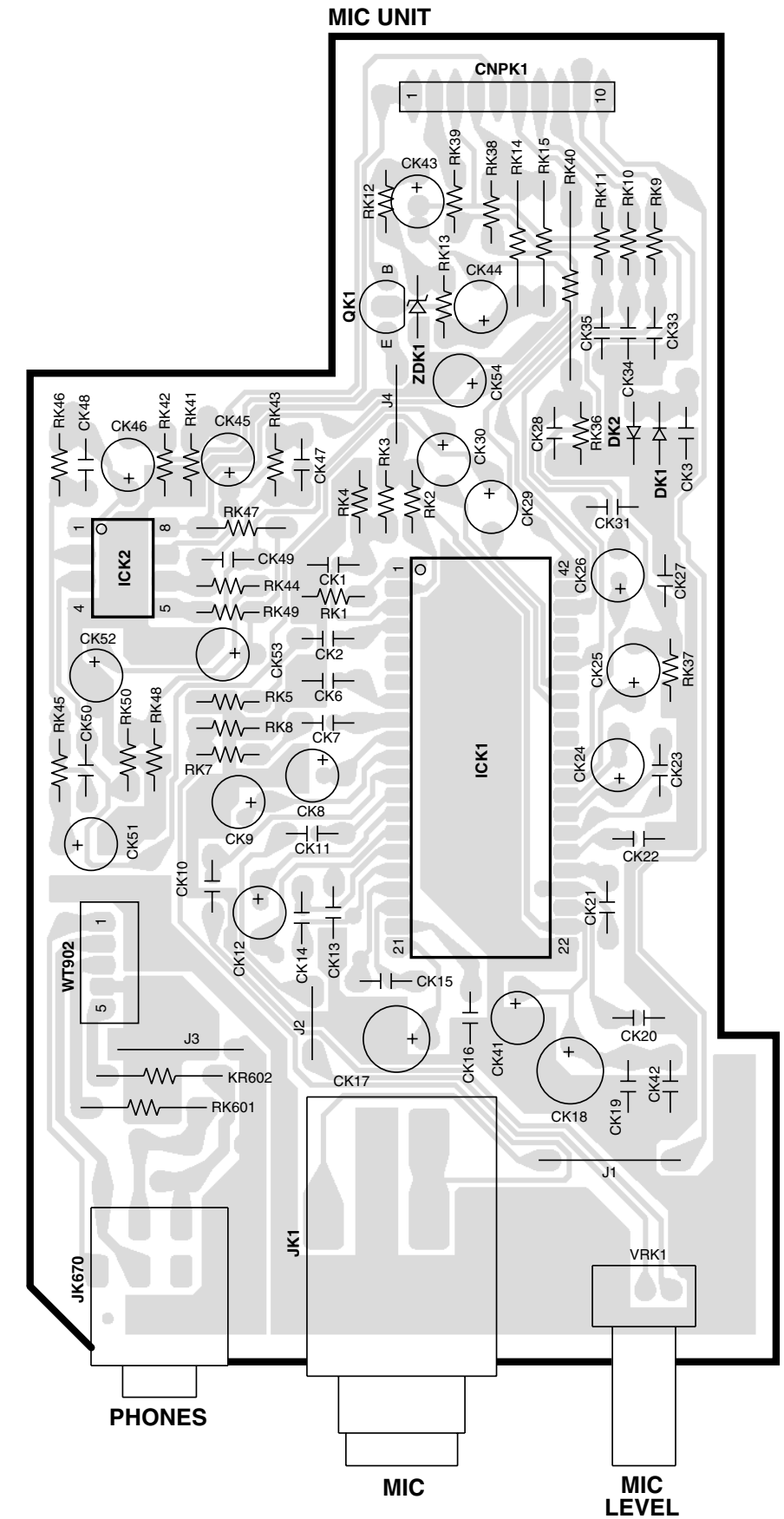
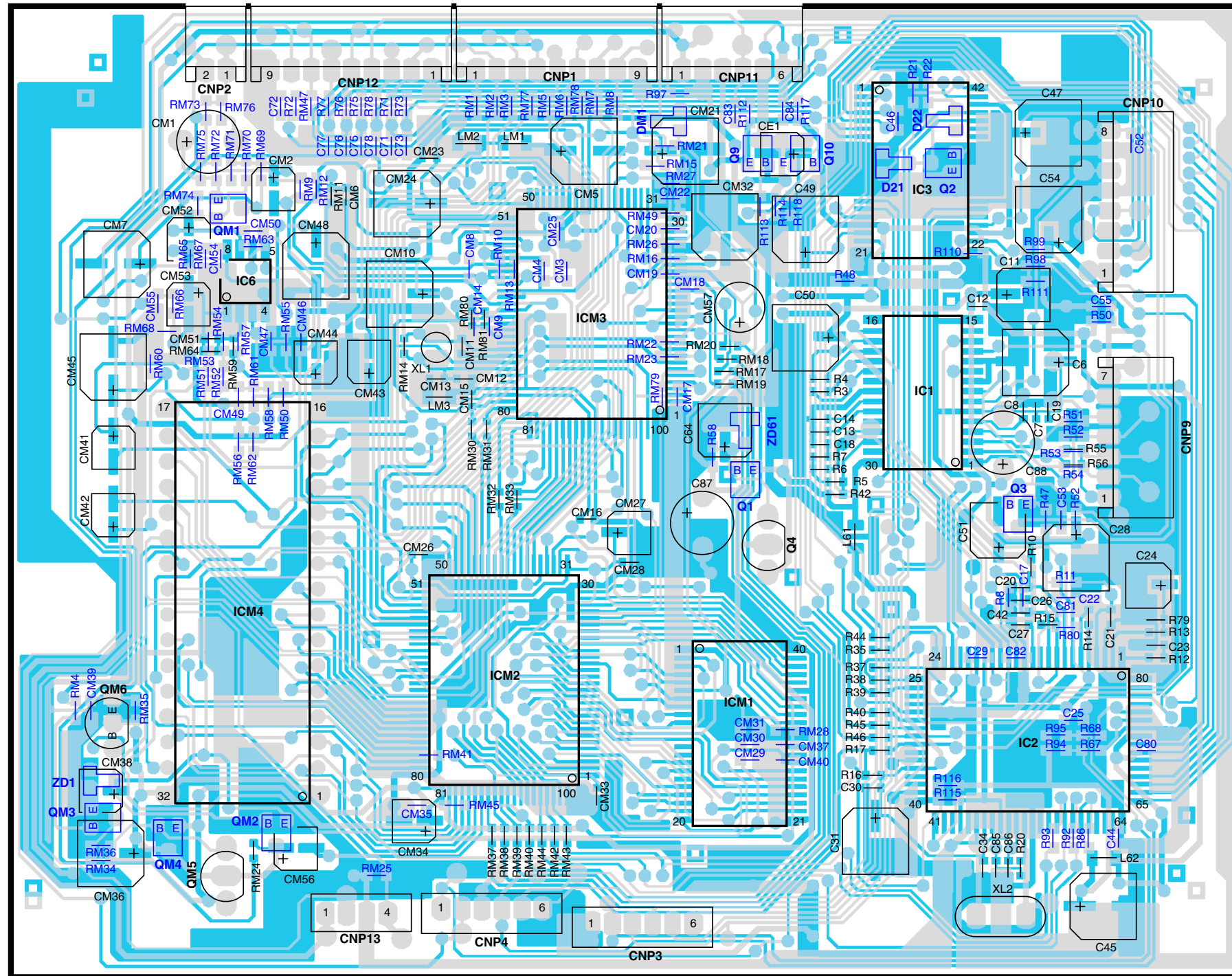

Refer to the schematic diagram for the value of resistors and capacitors.



# PC BOARD (Component side view)

## MAIN SECTION

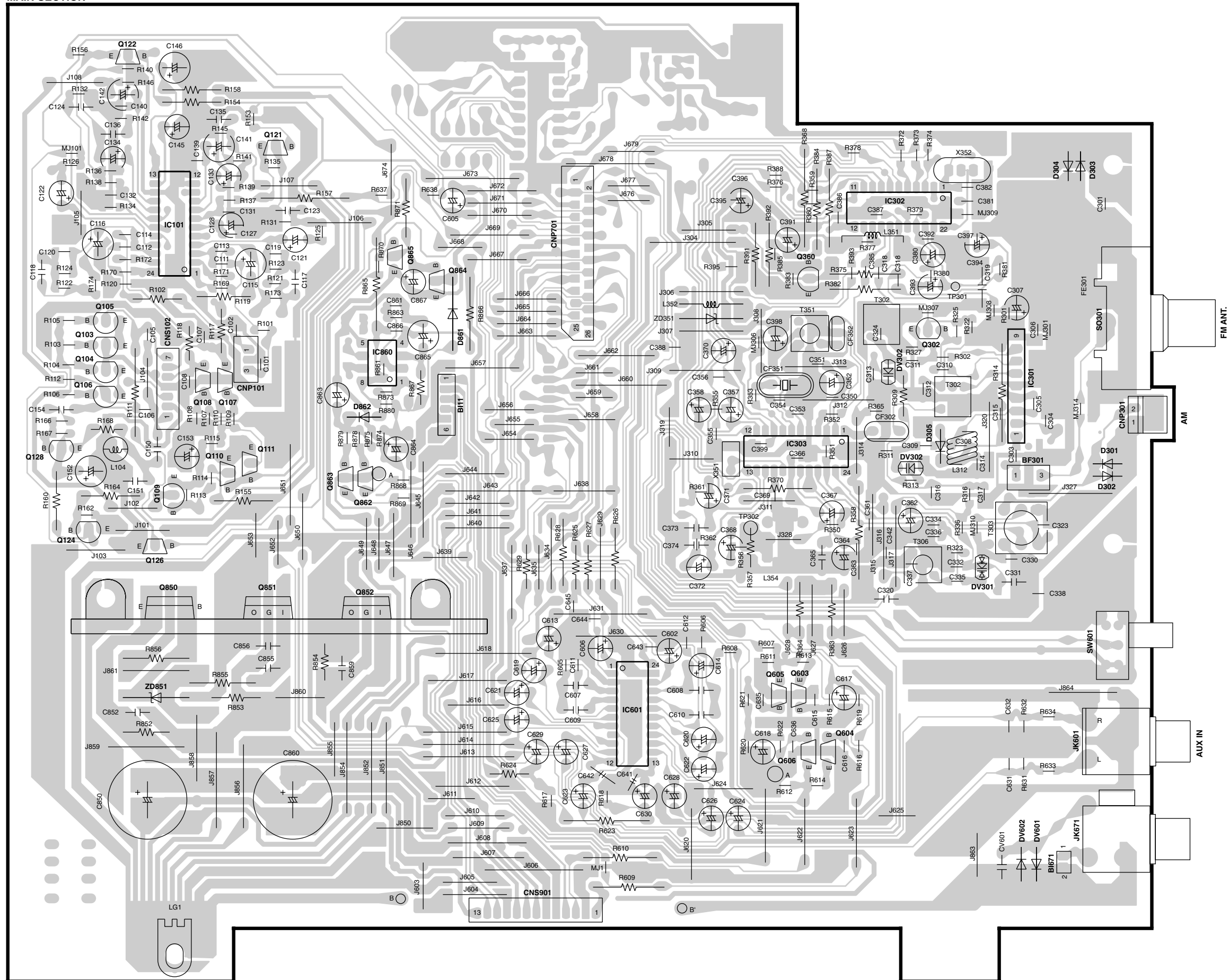

# PC BOARD(Component side view)

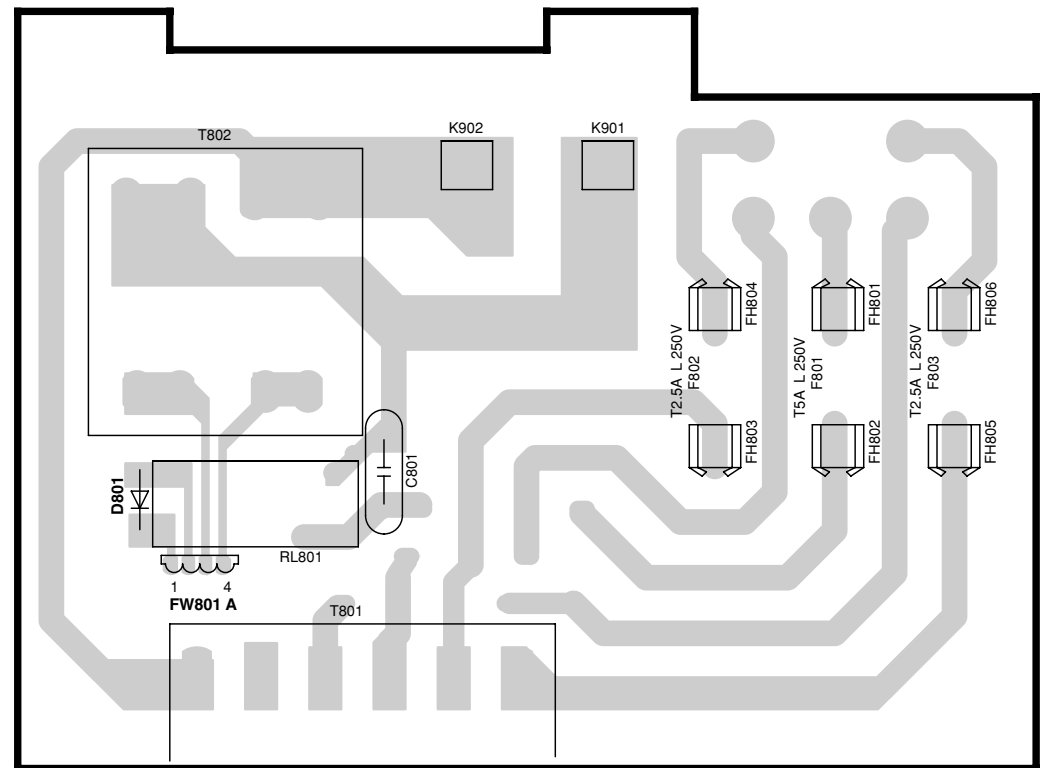
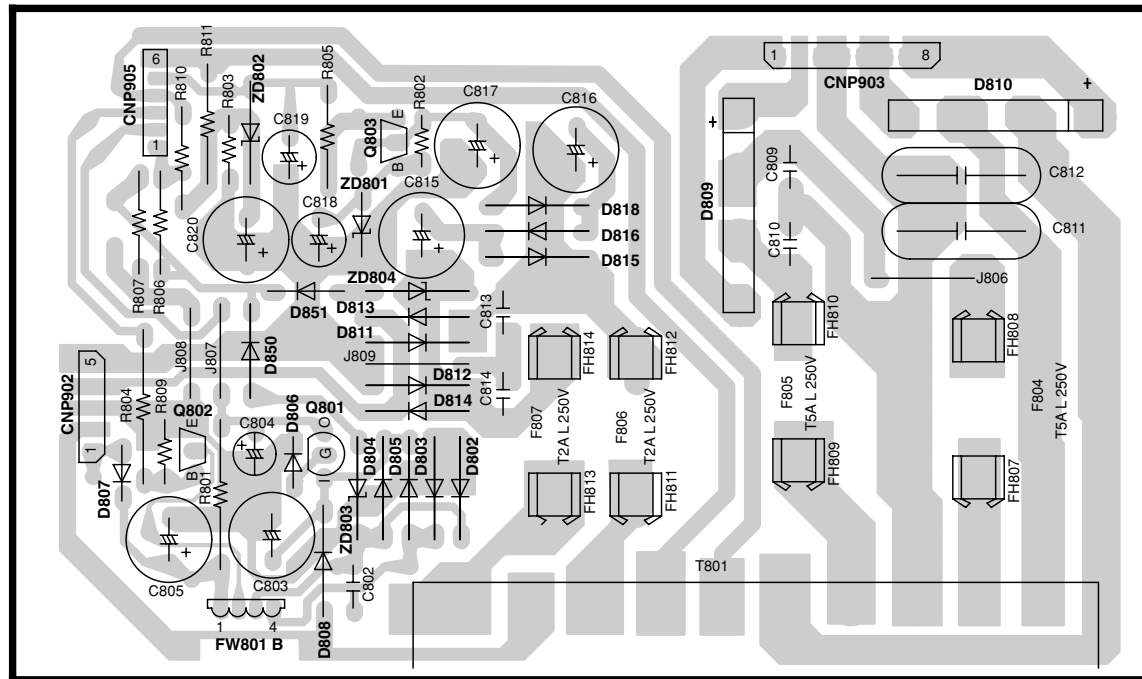
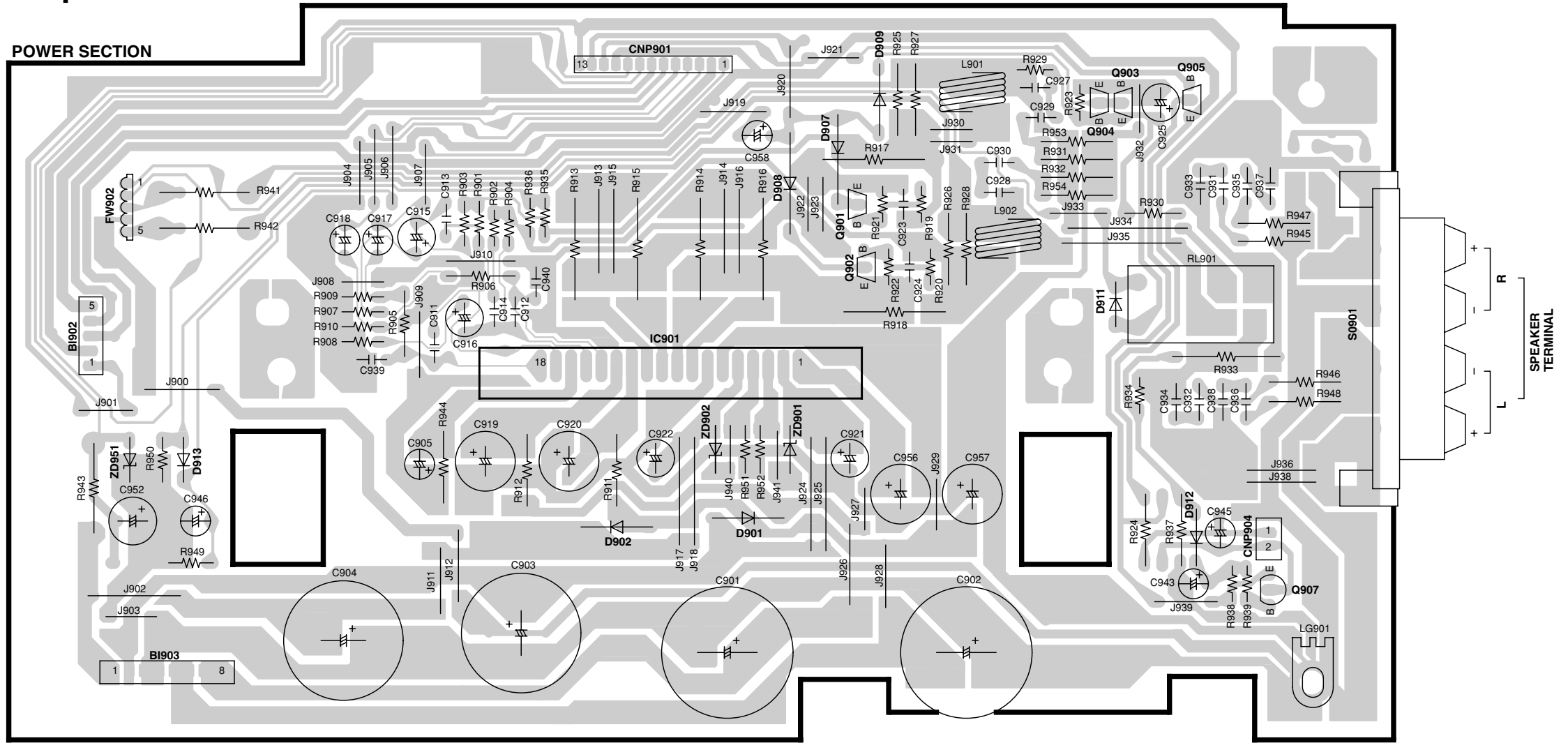

Refer to the schematic diagram for the value of resistors and capacitors.

# PC BOARD(Component side view)

## DISPLAY SECTION

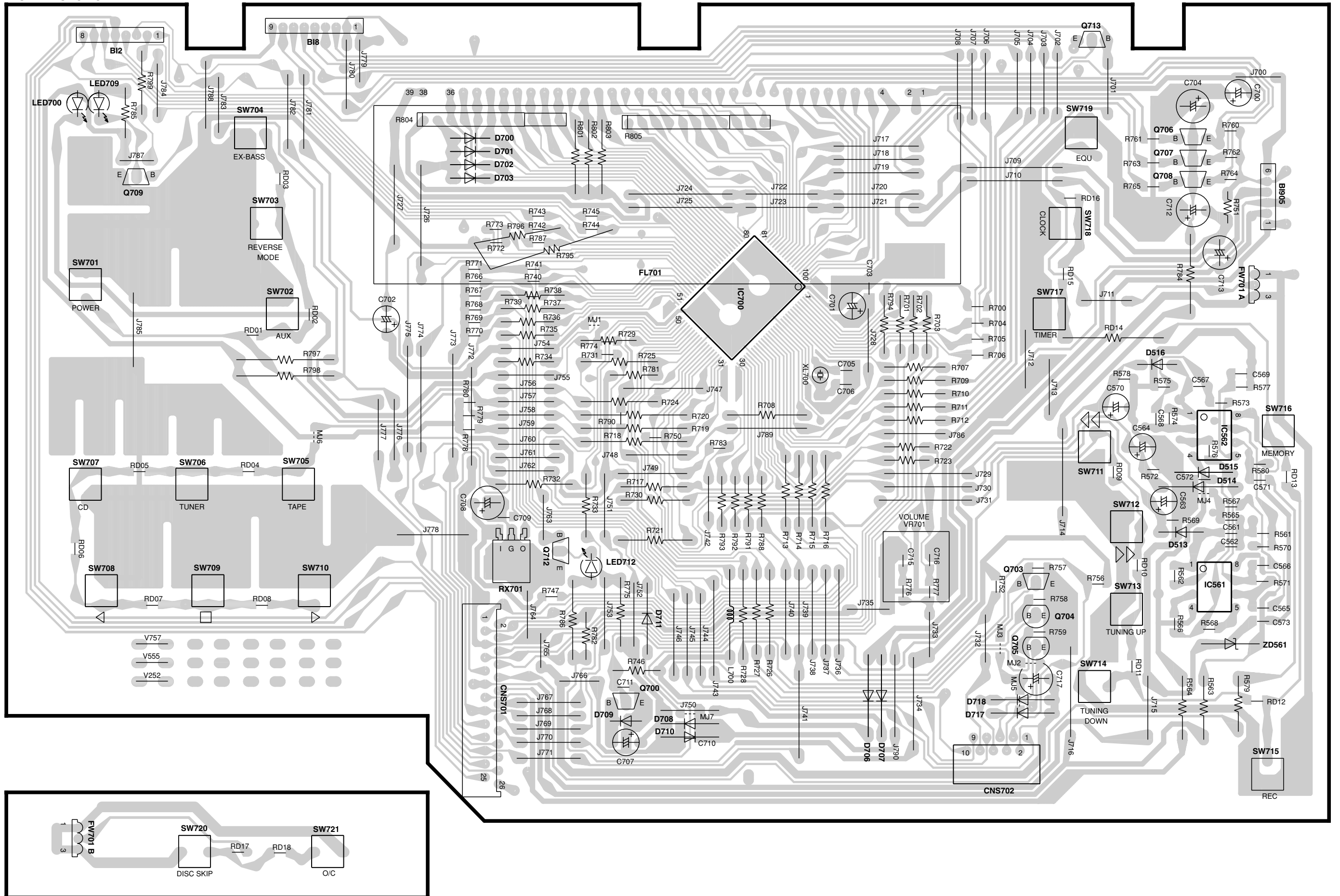

IC1 : LA9235M  
 IC2 : LC78636E  
 IC3 : M63001FP  
 IC6 : BA4558F  
 ICM1 : 1625635T  
 ICM2 : ES3880F  
 ICM3 : ES3889F  
 ICM4 : IX0455  
 Q2 : KRC102S  
 Q3 : KTA1504Y  
 Q4 : KTC3265Y  
 Q9,10 : KTC3875Y  
 QM1 : 2SC3265Y  
 QM3 : KRC104S  
 D21,22,DM1 : KDS193  
 ZD1 : EZ02W4R3Z  
 ZD61 : EZ02W3R9Z

--- RECORDING LINE  
 --- SIGNAL LINE  
 --- GND LINE  
 <-+B< +B LINE  
 <-B< -B LINE

CD/VCD/MP3 SECTION

PICKUP UNIT

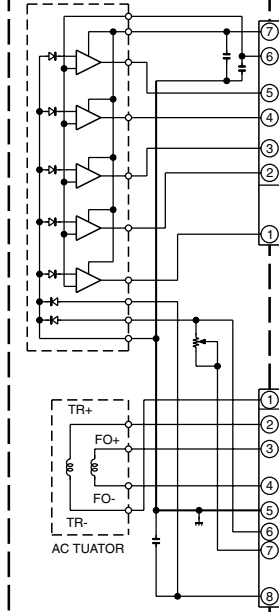

CD MOTOR PWB-D

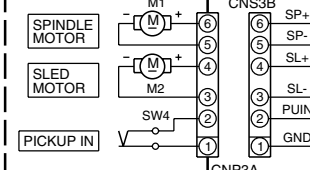

MIC SECTION

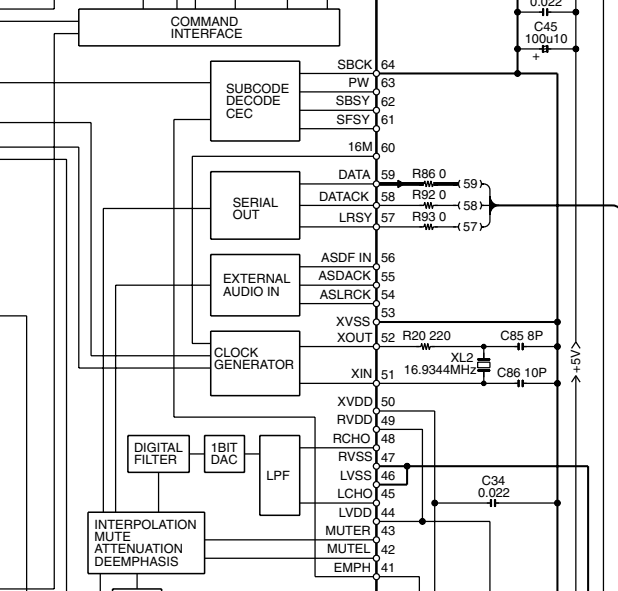
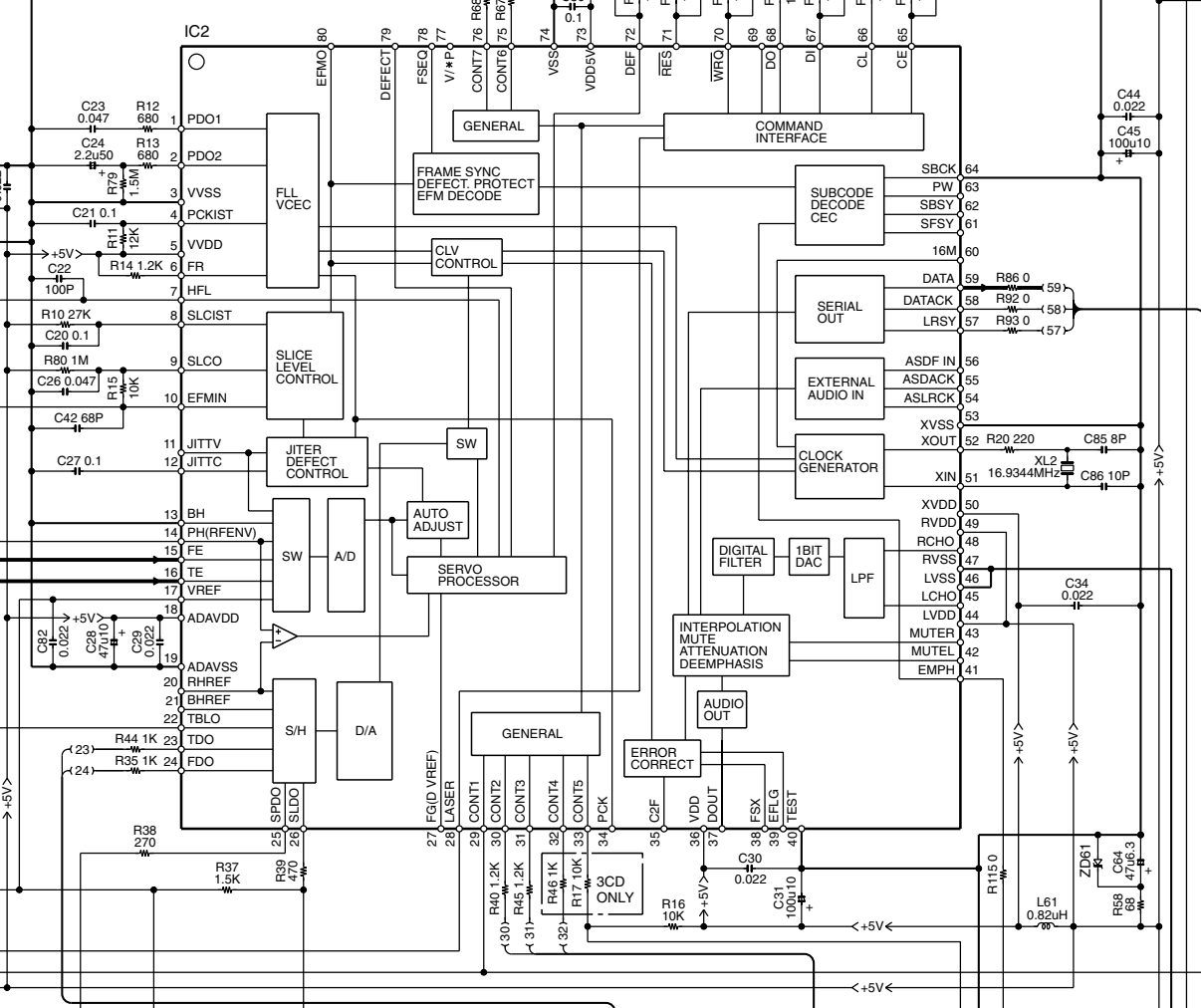
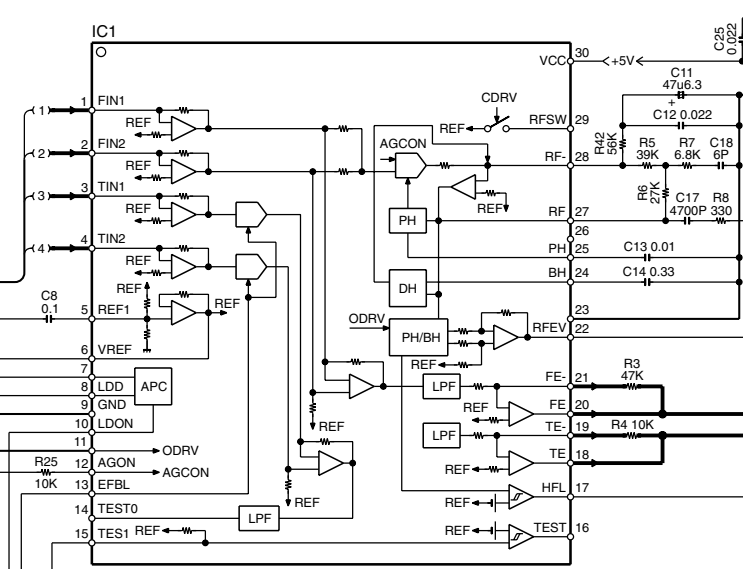
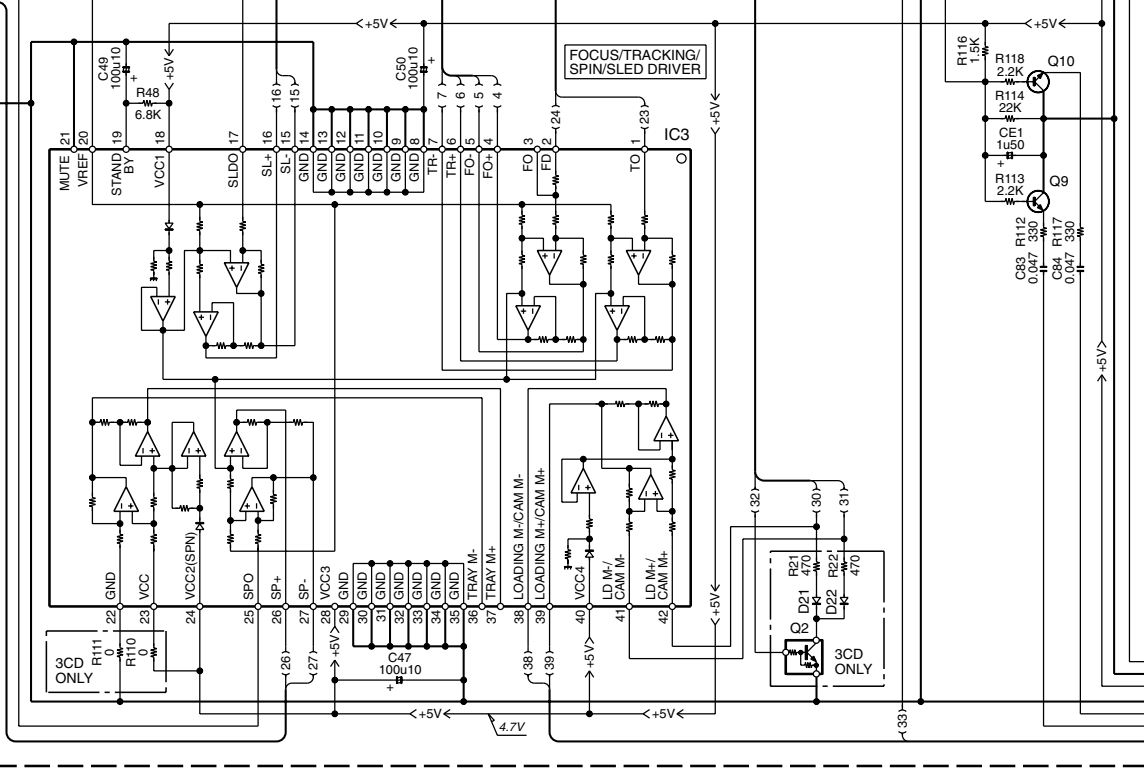
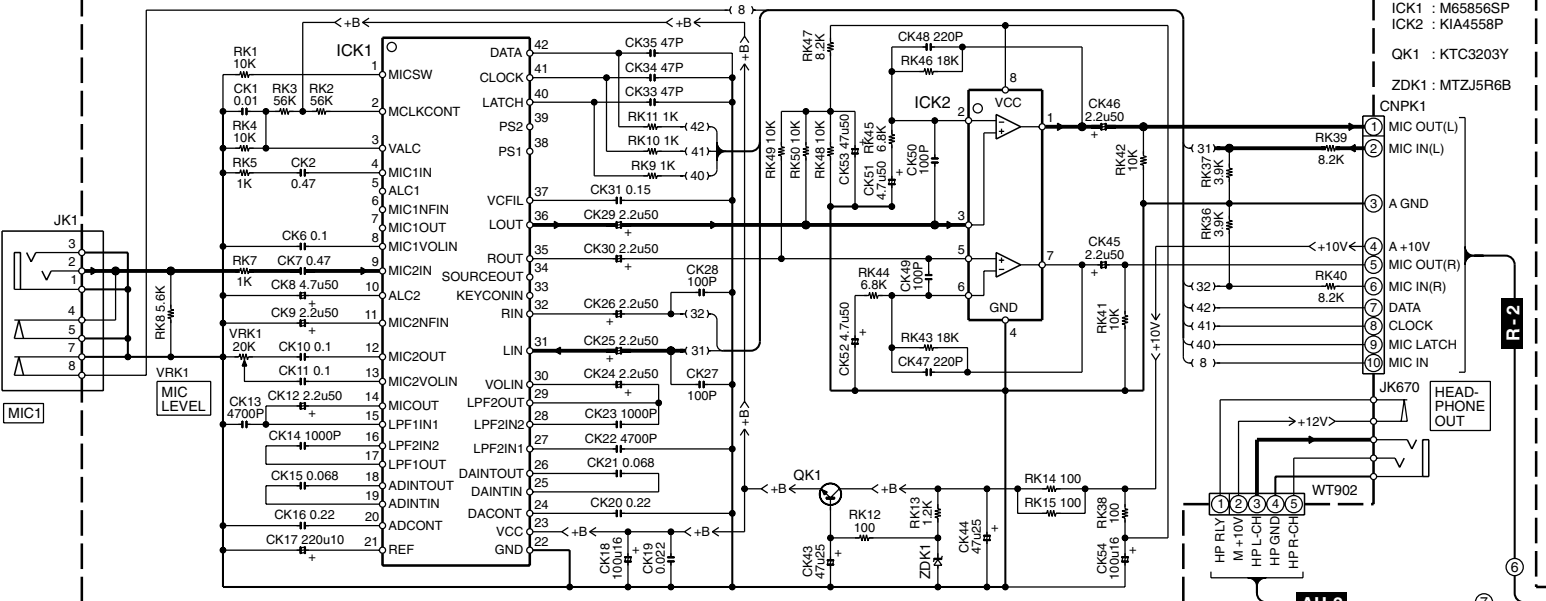

1  
2  
3  
4  
5  
6  
7

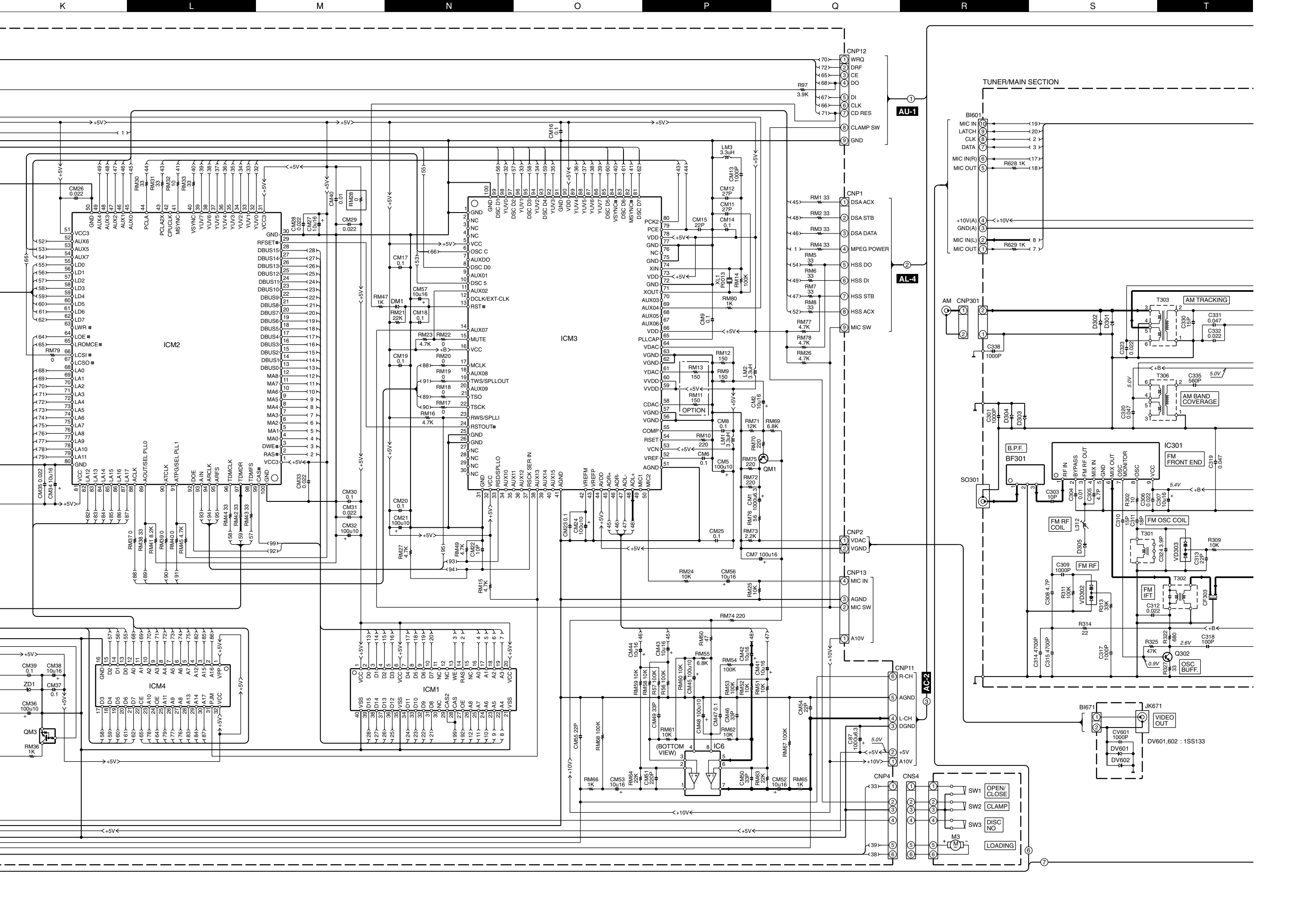

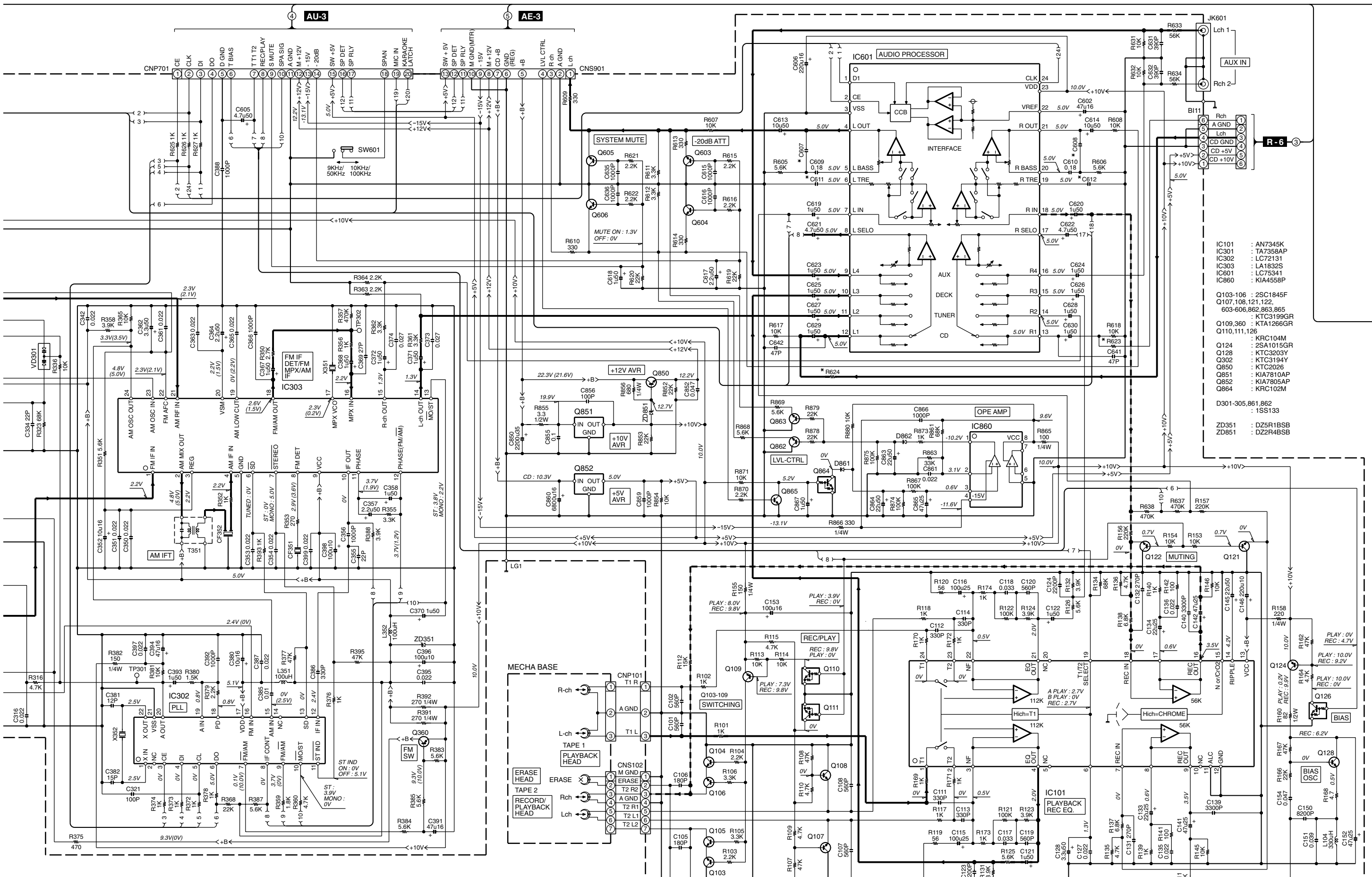

- IC101 : AN7345K
- IC301 : TA7358AP
- IC302 : LC72131
- IC303 : LA1832S
- IC601 : LC75341
- IC860 : KIA4558P
  
- Q103-106 : 2SC1845F
- Q107,108,121,122, 603-606,862,863,865 : KTC3199GR
- Q109,360 : KIA7805AP
- Q110,111,126 : KRC104M
- Q124 : 2SA1015GR
- Q128 : KTC3203Y
- Q302 : KTC3194Y
- Q850 : KTC2026
- Q851 : KIA7810AP
- Q852 : KIA7805AP
- Q864 : KRC102M
  
- D301-305,861,862 : 1SS133
- ZD351 : DZ5R1B5B
- ZD851 : DZ2R4B5B

MODEL NAME	C607, 608	C611, 612	C901, 902	D809	D810	IC901	R623, 624	R909, 910	R921, 922	R950	T801
RXD-V757	0.15	1500P	3300u71	TS6B04GM	D10XB60F	STK41203	820	56K	1.8K	1.2K	L07-3147-08
RXD-V555	0.12	1200P	3300u63	D3SBA60F	TS6B04GM	STK4121J	6.8K	12K	2.7K	1.5K	L07-3146-08

( ): RXD-V757

\*IC901  
POWER AMP

- IC901 : \*
- Q801 : AN78L05
- Q802,901-904 : KTC3199GR
- Q803 : KTA1274Y
- Q905 : KRC107M
- Q907 : KTC3203Y
- D801,806-808,850,851,907-909,911-913 : 1SS133
- D802-805,811-816,818,901,902 : 1N4004S
- D809 : \*
- D810 : \*
- ZD801 : DZ330BSC
- ZD802 : DZ6R2BSA
- ZD803 : DZ4R3BSC
- ZD804 : DZ110BSB
- ZD901,902 : DZ120BSB
- ZD951 : DZ130BSB

POWER SECTION

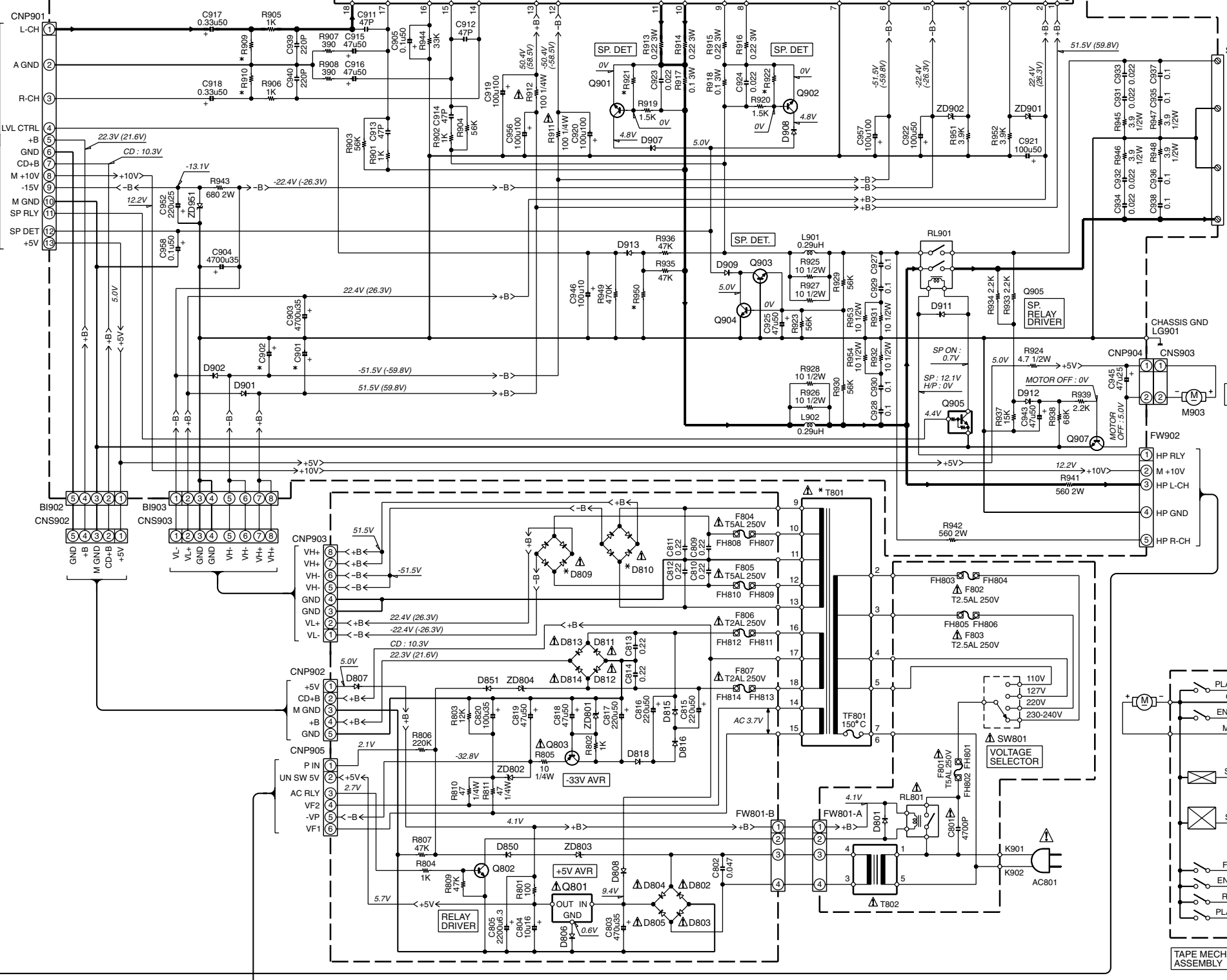

DISPLAY SECTION

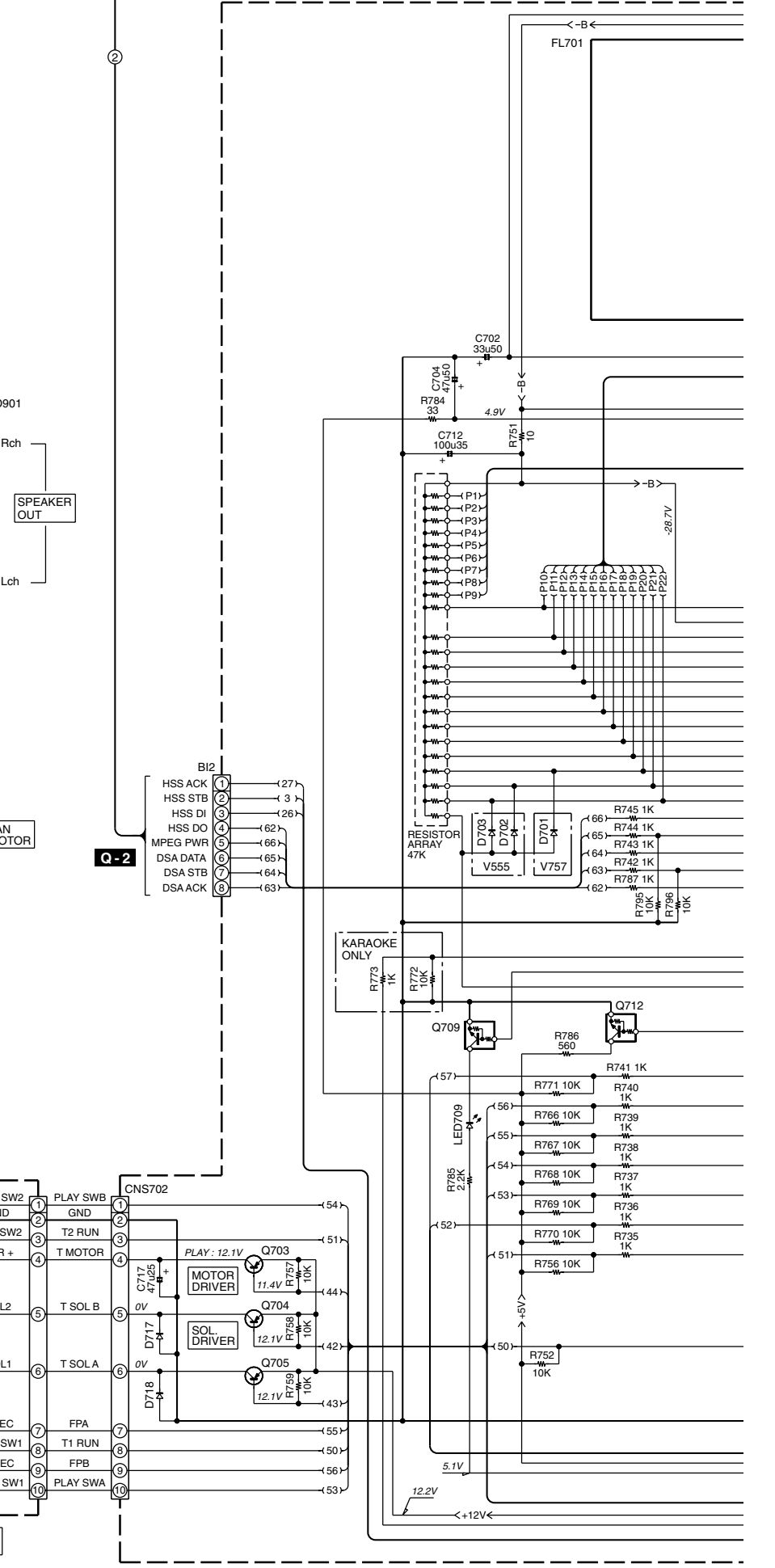

X-1

Q-2

TAPE MECHA. ASSEMBLY

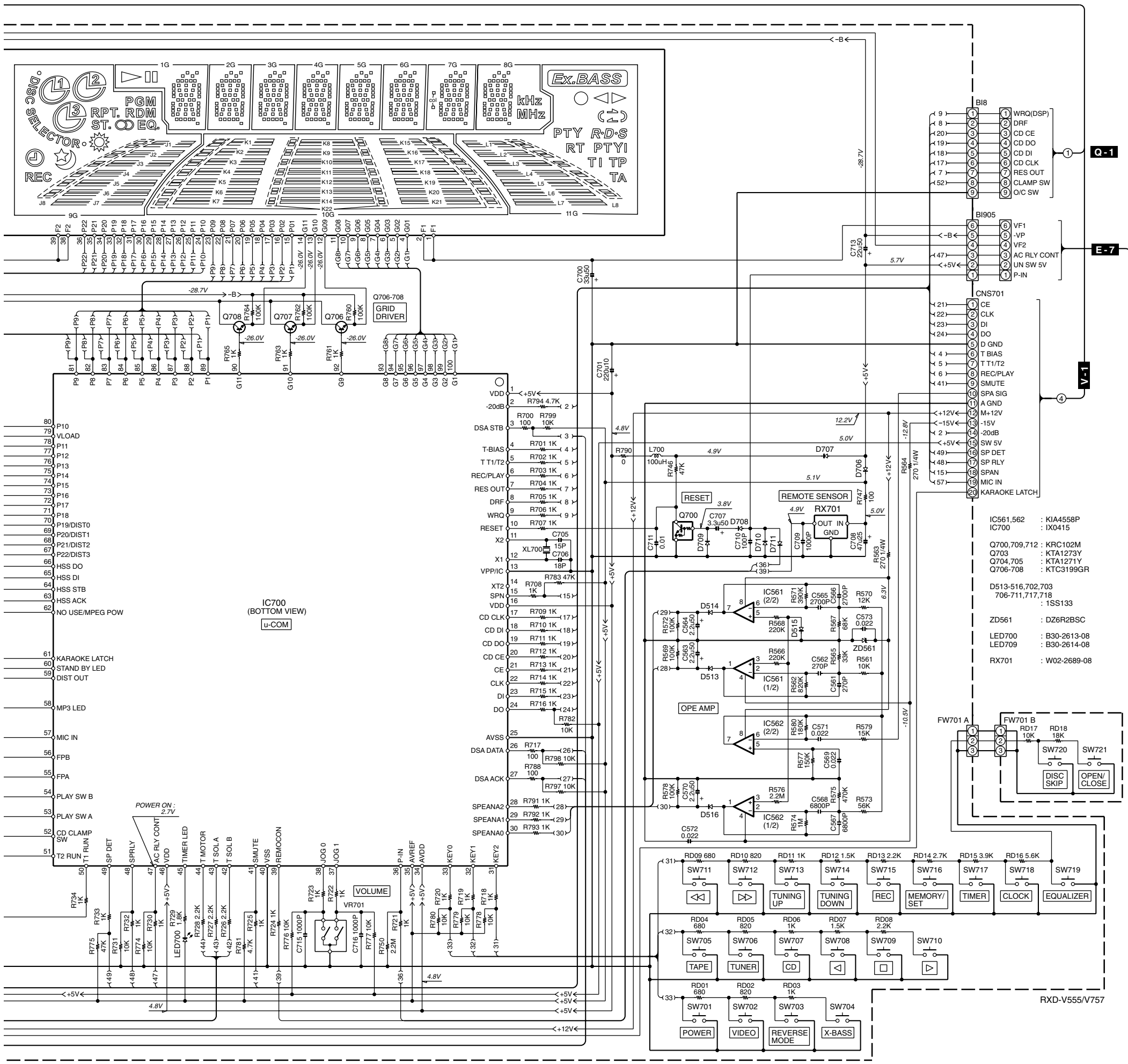

**CAUTION:** For continued safety, replace safety critical components only with manufacturer's recommended parts (refer to parts list).  $\Delta$  indicates safety critical components. For continued protection against risk of fire, replace only with same type and rating fuse(s). To reduce the risk of electric shock, leakage-current or resistance measurements shall be carried out (exposed parts are acceptably insulated from the supply circuit) before the appliance is returned to the customer.

The DC voltage is an actual reading measured with a high impedance type voltmeter as the AM/FM signal generator is specified to the conditions as shown in the list below. The measurement value may vary depending on the measuring instruments used or on the product. The value shown in ( ) is actual reading measured in the AM mode.

MODE	CARRIER	MODULATION		ANT INPUT
		FREQUENCY	DEVIATION	
FM	98MHz	1kHz	STEREO 67.5kHz 7.5kHz(Pilot)	60dB
AM	1000(999)kHz	400Hz	MONO 30% MOD	60dB

The DC voltage is an actual reading measured with a high impedance type voltmeter. The measurement value may vary depending on the measuring instruments used or on the product. Refer to the voltage during PLAY unless otherwise specified; The value shown in ( ) is the voltage measured at the moment of STOP.

The DC voltage is an actual reading measured with a high impedance type voltmeter with a cassette loaded at playback mode. The measurement value may vary depending on the measuring instruments used or on the product. Bias circuit DC voltage is measured while in the record mode.

DOLBY and the double-D symbol are trademarks of Dolby Laboratories Licensing Corporation. Noise reduction circuit made under license from Dolby Laboratories Licensing Corporation.

- IC561.562 : KIA4558P
- IC700 : IX0415
- Q700,709,712 : KRC102M
- Q703 : KTA1273Y
- Q704,705 : KTA1271Y
- Q706-708 : KTC3199GR
- D513-516,702,703 : 1SS133
- 706-711,717,718 : 1SS133
- ZD561 : DZ6R2BSC
- LED700 : B30-2613-08
- LED709 : B30-2614-08
- RX701 : W02-2689-08

# RXD-V555/V757



# RXD-V555/V757

## EXPLODED VIEW(CD MECHANISM)

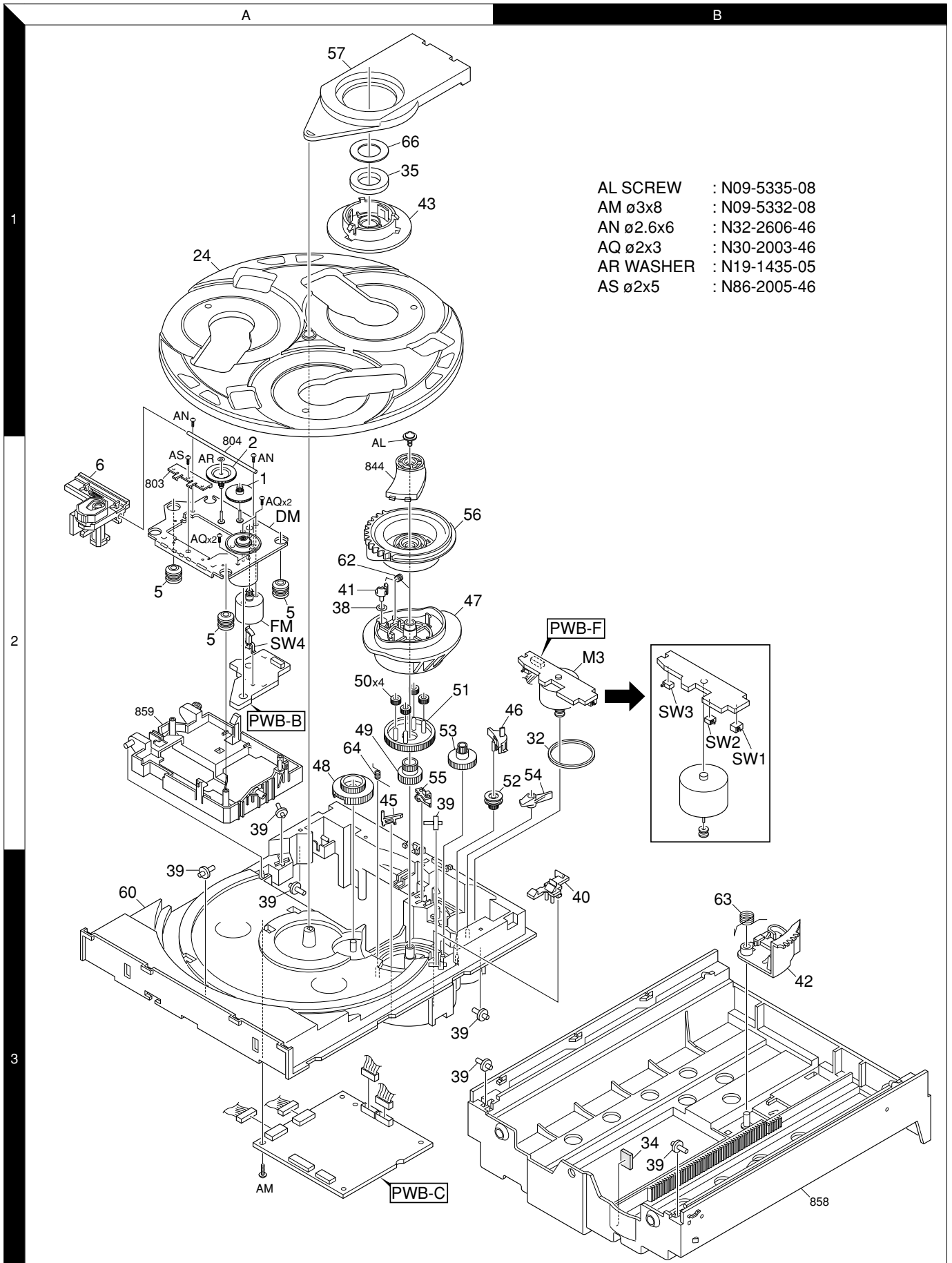

Parts with exploded numbers larger than 700 are not supplied.

Parts with exploded numbers larger than 700 are not supplied.

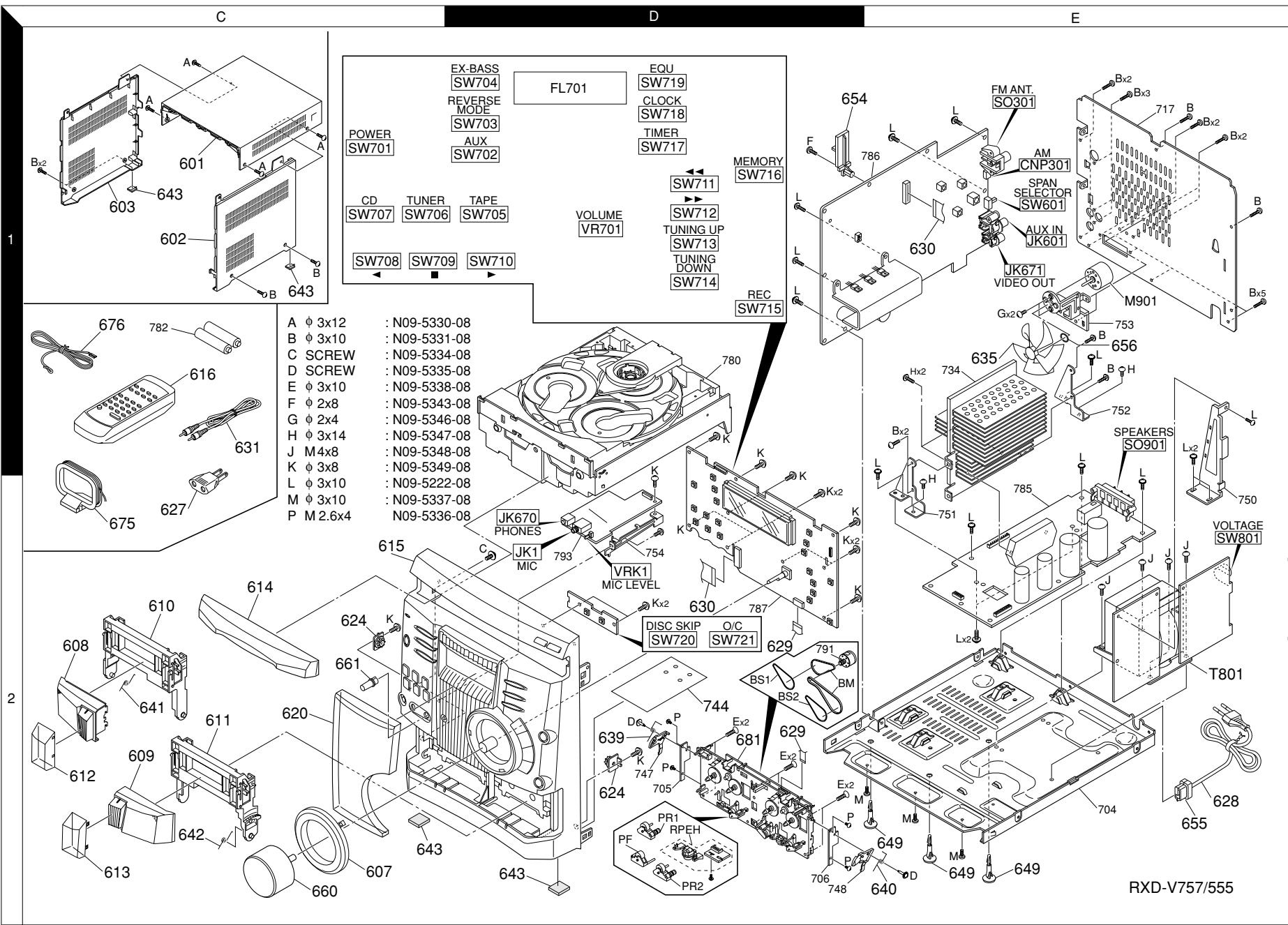

\* New Parts  
 Parts without **Parts No.** are not supplied.  
 Les articles non mentionnés dans le **Parts No.** ne sont pas fournis.  
 Teile ohne **Parts No.** werden nicht geliefert.

①

Ref. No	Add-ress	New Parts	Parts No.	Description	Desti-nation	Re-marks
<b>RXD-V555/V555-HV/757</b>						
601	1C		A02-3014-08	CABINET(TOP)	GCAB-1195AWSA	
602	1C		A02-3015-08	CABINET(R)	GITAS0092AWSA	
603	1C		A02-3016-08	CABINET(L)	GITAS0075AWSA	
607	2C		A21-3957-08	DRESS RING(KNO	HDECQ0703AWSA	
608	2C		A21-3958-08	CASSETTE LID(L)	GCOVA1365AWSA	
609	2C		A21-3959-08	CASSETTE LID(R)	GCOVA1366AWSA	
610	2C		A53-2251-08	CASS HOLDER(L)	GDORF0104AWSA	
611	2C		A53-2252-08	CASS HOLDER(R)	GDORF0105AWSA	
612	2C		A53-2254-08	FG(CAS L)	HDECQ0700AWSA	5,7
612	2C		A53-2282-08	FG(CAS L)	HDECQ0700AWSB	6
613	2C		A53-2255-08	FG(CAS R)	HDECQ0701AWSA	5,7
613	2C		A53-2283-08	FG(CAS R)	HDECQ0701AWSB	6
614	2C	*	A60-2220-08	PANEL(VCD)	GGOVA1411AWSA	
615	2D	*	A60-2221-08	FRT PANEL ASSY	CAB3581AASY1	5
615	2D	*	A60-2222-08	FRT PANEL ASSY	CAB3582AASY1	6
615	2D	*	A60-2223-08	FRT PANEL ASSY	CAB3574AASY1	7
616	1C	*	A70-1574-08	REMOTE CONTROL	RRMCG0275AWSA	
620	2C	*	B10-3833-08	FRONT GLASS	HDECQ0791AWSA	5
620	2C	*	B10-3834-08	FRONT GLASS	HDECQ0791AWSB	6
620	2C	*	B10-3835-08	FRONT GLASS	HDECQ0790AWSA	7
-	-	*	B60-5094-00	INST MANUAL (AR)		
-	-	*	B60-5095-00	INST MANUAL (EN/TC)		
624	2C,2E		D39-0355-08	DAMPER	MLIFP0008AWZZ	
BM	2D		D16-0780-08	MAIN BELT	FF19N-11	
BS1	2D		D16-0782-08	SUB BELT	FF19S-51	
BS2	2D		D16-0781-08	SUB BELT	FF19S-12	
PF	2D		D14-0821-08	PINCH ASSY	F514-134	
PR1	2D		D14-0822-08	PINCH ASSY	F514-135	
PR2	2D		D14-0820-08	PINCH ASSY	F514-133	
RPEH	2D		T39-0046-08	ROTATION HEAD	F513-853	
△ 627	1C		E03-0115-05	AC PLUG ADAPTER		M
△ 628	2E		E30-7227-08	AC POWER CORD	QACCE0010AW00	
629	2D		E35-2991-08	FFC WIRE10P	QCNWN1913AWZZ	
630	1E,2D		E35-3070-08	FFC WIRE26P	QCNWN1915AWZZ	
631	1C		E30-7255-08	CDG VIDEO CRD	QCNWG0005AWZZ	
635	1E		F09-0163-08	FAN	NFANP0001AWZZ	
639	2D		G01-4280-08	SPRING	MSPRD0109AWFJ	
640	2E		G01-4281-08	SPRING	MSPRD0110AWFJ	
641	2C		G01-4293-08	SPRING	MSPRD0151AWFJ	
642	2C		G01-4294-08	SPRING	MSPRD0152AWFJ	
643	2C,2D		G13-2514-08	CUSHION(FOOT)	PCUSG0022AWZZ	
-	-		H10-7771-08	POLY FOAM FIXT	SPAKA0307AWZZ	
-	-		H25-1706-08	BAG(UNIT)	SSAKH0061AWZZ	
-	-		H25-1707-08	BAG CAUTION	CAUT1513A	
-	-		H25-1708-08	BAG(ACCES)	SSAKA0007AWZZ	
-	-	*	H50-4409-08	ITEM CARTON	SPAKC1301AWZZ	5
-	-	*	H50-4410-08	ITEM CARTON	SPAKC1310AWZZ	6
-	-	*	H50-4411-08	ITEM CARTON	SPAKC1300AWZZ	7
649	2E		J19-6232-08	HOLDER	LX-LZ0012AWZZ	
654	1E		J19-6236-08	UNIT HOLDER	LHLDLF1019AWSA	
△ 655	2E		J42-0338-08	POWER CORD BUS	LBSHC0002AWZZ	

L : Scandinavia    K : USA    P : Canada    R : Mexico    C : China    I : Malaysia  
 Y : PX(Far East,Hawaii)    T : England    E : Europe    G : Germany    V : China(Shanghai)  
 Y : AAFES(Europe)    X : Australia    Q : Russia    H : Korea    M : Other Areas    △ indicates safety critical components .

\* New Parts  
 Parts without **Parts No.** are not supplied.  
 Les articles non mentionnés dans le **Parts No.** ne sont pas fournis.  
 Teile ohne **Parts No.** werden nicht geliefert.

②

Ref. No	Add-ress	New Parts	Parts No.	Description	Desti-nation	Re-marks
656	1E		J69-0223-08	RING(FAN)	CSPR1431C	
660	2C		K27-2470-08	KNOB (VOLUME)	JKNBZ0794AWSA	
661	2C	*	K29-8153-08	MIC VOL KNOB	JKNBZ0806AWSA	
△ T801	2E		L07-3146-08	POWER TRANS 45	RTRNP0368AWZZ	5,6
△ T801	2E		L07-3147-08	POWER TRANS 7	RTRNP0365AWZZ	7
A			N09-5330-08	MACHINE SCREW	XEBSD30P12000	
B			N09-5331-08	MACHINE SCREW	XJBSD30P10000	
C			N09-5334-08	MACHINE SCREW	LX-BZ2222AXZZ	
D			N09-5335-08	MACHINE SCREW	LX-HZ0009AWFD	
E			N09-5338-08	MACHINE SCREW	XESSD30P10000	
F			N09-5343-08	MACHINE SCREW	XBPSD20P08000	
G			N09-5346-08	MACHINE SCREW	XBBSD20P04000	
H			N09-5347-08	MACHINE SCREW	XJBSD30P14000	
J			N09-5348-08	MACHINE SCREW	XHBSD40P08000	
K			N09-5349-08	MACHINE SCREW	XEBSD30P08000	
L			N09-5222-08	MACHINE SCREW	LX-JZ0010AFFD	
M			N09-5337-08	MACHINE SCREW	XJSSD30P10000	
P			N09-5336-08	MACHINE SCREW	XHBSD26P04000	
675	2C		T90-0879-08	LOOP ANTENNA	QANTL0008AWZZ	
676	2C		T90-0883-08	FM LEAD ANTENN	FANT1535A	
M901	1E		T41-0142-08	MOTOR(FAN)	RMOTV0027AWZZ	
681	2D		W04-0019-08	MECHANISM(CAS)	KMECB0020AWZZ	
<b>ELECTRICAL PARTS</b>						
FL701			NA11MM36	FL TUBE	VVKNA11MM36-1	
LED700			B30-2613-08	LED(YELLOW)	VHP3105UYT1-1T	
LED709			B30-2614-08	LED(RED)	VHP31URT21+-1+	
C6			CE04LW1A101M	ELECTRO	100UF	10WV
C8			CK73GB1C104K	CHIP C	0.10UF	K
C11			CE04KW0J470M	ELECTRO	47UF	6.3WV
C12			CK73GB1E223K	CHIP C	0.022UF	K
C13			CK73GB1C103K	CHIP C	0.010UF	K
C14			CK73GB1C334Z	CHIP C	0.33UF	Z
C17			CK73GB1H472K	CHIP C	4700PF	K
C18			CC73GCH1H080D	CHIP C	8.0PF	D
C19			CK73GB1E223K	CHIP C	0.022UF	K
C20			CK73GB1C104K	CHIP C	0.10UF	K
C21			CK73GB1C104K	CHIP C	0.10UF	K
C22			CC73GCH1H101J	CHIP C	100PF	J
C23			CK73GB1C473K	CHIP C	0.047UF	K
C24			CE04LW1H2R2M	ELECTRO	2.2UF	50WV
C25			CK73GB1E223K	CHIP C	0.022UF	K
C26			CK73GB1C473K	CHIP C	0.047UF	K
C27			CK73GB1C104K	CHIP C	0.10UF	K
C28			CE04LW1A470M	ELECTRO	47UF	10WV
C29			CK73GB1E223K	CHIP C	0.022UF	K
C30			CK73GB1E223K	CHIP C	0.022UF	K
C31			CE04LW1A101M	ELECTRO	100UF	10WV
C34			CK73GB1E223K	CHIP C	0.022UF	K
C42			CC73GCH1H680J	CHIP C	68PF	J
C44			CK73GB1E223K	CHIP C	0.022UF	K
C45			CE04LW1A101M	ELECTRO	100UF	10WV

L : Scandinavia    K : USA    P : Canada    R : Mexico    C : China    I : Malaysia  
 Y : PX(Far East,Hawaii)    T : England    E : Europe    G : Germany    V : China(Shanghai)  
 Y : AAFES(Europe)    X : Australia    Q : Russia    H : Korea    M : Other Areas    △ indicates safety critical components .

PARTS LIST

RXD-V555/V757

\* New Parts

Parts without **Parts No.** are not supplied.Les articles non mentionnés dans le **Parts No.** ne sont pas fournis.Teile ohne **Parts No.** werden nicht geliefert.

③

Ref. No	Add-ress	New Parts	Parts No.	Description	Desti-nation	Re-marks
C46			CK73GB1E223K	CHIP C	0.022UF	K
C47			CE04LW1A101M	ELECTRO	100UF	10WV
C49_50			CE04KW1A101M	ELECTRO	100UF	10WV
C51			CE04KW0J470M	ELECTRO	47UF	6.3WV
C52			CK73GB1C103K	CHIP C	0.010UF	K
C53			CK73GB1H102K	CHIP C	1000PF	K
C54			CE04LW1A470M	ELECTRO	47UF	10WV
C55			CK73GB1C103K	CHIP C	0.010UF	K
C64			CE04KW0J470M	ELECTRO	47UF	6.3WV
C71			CC73GCH1H101J	CHIP C	100PF	J
C72			CK73GB1C103K	CHIP C	0.010UF	K
C73			CC73GCH1H101J	CHIP C	100PF	J
C76			CC73GCH1H101J	CHIP C	100PF	J
C78			CC73GCH1H101J	CHIP C	100PF	J
C80			CK73GB1C104K	CHIP C	0.10UF	K
C81			CK73GB1E223K	CHIP C	0.022UF	K
C82			CK73GB1E223K	CHIP C	0.022UF	K
C83_34			CK73GB1H473K	CHIP C	0.047UF	K
C85			CC73GCH1H080D	CHIP C	8.0PF	D
C86			CC73GCH1H100D	CHIP C	10PF	D
C87_88			CE04LW0J102M	ELECTRO	1000UF	6.3WV
C101_102			CC73FCH1H561J	CHIP C	560PF	J
C105_106			CC73FCH1H181J	CHIP C	180PF	J
C107_108			CC73FCH1H561J	CHIP C	560PF	J
C111-114			CC73FCH1H331J	CHIP C	330PF	J
C115_116			CE04LW1E101M	ELECTRO	100UF	25WV
C117_118			CK73EB1E333K	CHIP C	0.033UF	K
C119_120			CC73FCH1H561J	CHIP C	560PF	J
C121_122			CE04LW1H010M	ELECTRO	1.0UF	50WV
C123_124			CK45FB1H222K	CERAMIC	2200PF	K
C127			CK73EB1E223K	CHIP C	0.022UF	K
C128			CE04LW1H3R3M	ELECTRO	3.3UF	50WV
C131_132			CC73ECH1H271J	CHIP C	270PF	J
C133_134			CE04LW1E220M	ELECTRO	22UF	25WV
C135_136			CK45FB1H223Z	CERAMIC	0.022UF	Z
C139_140			CK73EB1H332K	CHIP C	3300PF	K
C141_142			CE04LW1E470M	ELECTRO	47UF	25WV
C145			CE04LW1H220M	ELECTRO	22UF	50WV
C146			CE04LW1A221M	ELECTRO	220UF	10WV
C150			C92-0248-08	MYLAR	8200PF	J
C151			CQ93FMG1H393J	MYLAR	0.039UF	J
C152			CE04LW1E470M	ELECTRO	47UF	25WV
C153			CE04LW1C101M	ELECTRO	100UF	16WV
C154			CK45FB1H473Z	CERAMIC	0.047UF	Z
C301			CK73EB1H102K	CHIP C	1000PF	K
C303			CC73ECH1H100D	CHIP C	10PF	D
C304			CK73FB1E103K	CHIP C	0.010UF	K
C305			C91-1641-08	CHIP C	4.7PF	J
C306			CK73EB1E223K	CHIP C	0.022UF	K
C307			CE04LW1C100M	ELECTRO	10UF	16WV
C308			C91-1641-08	CHIP C	4.7PF	J
C309			CK73EB1H102K	CHIP C	1000PF	K
C310			CC73ECH1H150J	CHIP C	15PF	J
C311			CC73ECH1H180J	CHIP C	18PF	J
C312			CK73EB1E223K	CHIP C	0.022UF	K

L : Scandinavia K : USA P : Canada R : Mexico C : China I : Malaysia  
 Y : PX(Far East,Hawaii) T : England E : Europe G : Germany V : China(Shanghai)  
 Y : AAFES(Europe) X : Australia Q : Russia H : Korea M : Other Areas  $\Delta$  indicates safety critical components.

\* New Parts

Parts without **Parts No.** are not supplied.Les articles non mentionnés dans le **Parts No.** ne sont pas fournis.Teile ohne **Parts No.** werden nicht geliefert.

④

Ref. No	Add-ress	New Parts	Parts No.	Description	Desti-nation	Re-marks
C313			CC73ECH1H220J	CHIP C	22PF	J
C314_315			CK73EB1H472K	CHIP C	4700PF	K
C316			CK73EB1E223K	CHIP C	0.022UF	K
C317			CK73EB1H102K	CHIP C	1000PF	K
C318			CC73ECH1H101J	CHIP C	100PF	J
C319_320			CK45FB1H473Z	CERAMIC	0.047UF	Z
C321			CK45FB1H101K	CERAMIC	100PF	K
C323			CK73EB1E223K	CHIP C	0.022UF	K
C324			C91-1642-08	CHIP C	3.9PF	J
C330			CC73ECH1H150J	CHIP C	15PF	J
C331			CK45FB1H473Z	CERAMIC	0.047UF	Z
C332			CK73EB1E223K	CHIP C	0.022UF	K
C334			CC73ECH1H220J	CHIP C	22PF	J
C335			CC73FCH1H561J	CHIP C	560PF	J
C338			CK73EB1H102K	CHIP C	1000PF	K
C342			CK73EB1E223K	CHIP C	0.022UF	K
C350_351			CK73EB1E223K	CHIP C	0.022UF	K
C352			CE04LW1C100M	ELECTRO	10UF	16WV
C353_354			CK73EB1E223K	CHIP C	0.022UF	K
C355			CC73ECH1H220J	CHIP C	22PF	J
C356			CK73EB1H102K	CHIP C	1000PF	K
C357			CE04LW1H2R2M	ELECTRO	2.2UF	50WV
C358			CE04LW1H010M	ELECTRO	1.0UF	50WV
C361			CK73EB1E223K	CHIP C	0.022UF	K
C362			CE04LW1H3R3M	ELECTRO	3.3UF	50WV
C363			CK73EB1E223K	CHIP C	0.022UF	K
C364			CE04LW1H2R2M	ELECTRO	2.2UF	50WV
C365			CK45FB1H223K	CERAMIC	0.022UF	K
C366			CK73EB1H102K	CHIP C	1000PF	K
C367_368			CE04LW1H010M	ELECTRO	1.0UF	50WV
C369			CC73ECH1H270J	CHIP C	27PF	J
C370-372			CE04LW1H010M	ELECTRO	1.0UF	50WV
C373_374			CK45FB1H273K	CERAMIC	0.027UF	K
C380			CE04LW1C100M	ELECTRO	10UF	16WV
C381			CC73ECH1H120J	CHIP C	12PF	J
C382			CC73ECH1H150J	CHIP C	15PF	J
C385			CK73FB1E103K	CHIP C	0.010UF	K
C386			CC73FCH1H331J	CHIP C	330PF	J
C387			CK73EB1E223K	CHIP C	0.022UF	K
C388			CK73EB1H102K	CHIP C	1000PF	K
C391			CE04LW1C470M	ELECTRO	47UF	16WV
C392			CK73EB1H102K	CHIP C	1000PF	K
C393			CE04LW1H010M	ELECTRO	1.0UF	50WV
C394			CE04LW1C470M	ELECTRO	47UF	16WV
C395			CK73EB1E223K	CHIP C	0.022UF	K
C396			CE04LW1A101M	ELECTRO	100UF	10WV
C397			CK73EB1E223K	CHIP C	0.022UF	K
C398			CE04LW1A101M	ELECTRO	100UF	10WV
C399			CK73EB1E223K	CHIP C	0.022UF	K
C561_562			CC73ECH1H271J	CHIP C	270PF	J
C563_564			CE04LW1H2R2M	ELECTRO	2.2UF	50WV
C565_566			CK73EB1H272K	CHIP C	2700PF	K
C567_568			CK73EB1H682K	CHIP C	6800PF	K
C569			CK73EB1E223K	CHIP C	0.022UF	K
C570			CE04LW1H2R2M	ELECTRO	2.2UF	50WV

L : Scandinavia K : USA P : Canada R : Mexico C : China I : Malaysia  
 Y : PX(Far East,Hawaii) T : England E : Europe G : Germany V : China(Shanghai)  
 Y : AAFES(Europe) X : Australia Q : Russia H : Korea M : Other Areas  $\Delta$  indicates safety critical components.

\* New Parts  
Parts without **Parts No.** are not supplied.  
Les articles non mentionnés dans le **Parts No.** ne sont pas fournis.  
Teile ohne **Parts No.** werden nicht geliefert.

5

Ref. No	Add-ress	New Parts	Parts No.	Description	Desti-nation	Re-marks
C571-573			CK73EB1E223K	CHIP C 0.022UF	K	
C602			CE04LW1C470M	ELECTRO 47UF	16WV	
C605			CE04LW1H4R7M	ELECTRO 4.7UF	50WV	
C606			CE04LW1C221M	ELECTRO 220UF	16WV	
C607,608			CF92FV1H124J	MF-C 0.12UF	J	5,6
C607,608			CF92FV1H154J	MF-C 0.15UF	J	7
C609,610			CF92FV1H184J	MF-C 0.18UF	J	
C611,612			CK73FB1E152K	CHIP C 1500PF	K	7
C611,612			CK73FB1H122K	CHIP C 1200PF	K	5,6
C613,614			CE04LW1H100M	ELECTRO 10UF	50WV	
C615,616			CK73EB1H102K	CHIP C 1000PF	K	
C617			CE04LW1H2R2M	ELECTRO 2.2UF	50WV	
C618			CE04LW1H010M	ELECTRO 1.0UF	50WV	
C619,620			CE04LW1H010M	ELECTRO 1.0UF	50WV	
C621,622			CE04LW1H4R7M	ELECTRO 4.7UF	50WV	
C623-630			CE04LW1H010M	ELECTRO 1.0UF	50WV	
C631,632			CC73FCH1H391J	CHIP C 390PF	J	
C635,636			CK73EB1H102K	CHIP C 1000PF	K	
C641,642			CC45FSL1H470J	CERAMIC 47PF	J	
C700			CE04LW1H330M	ELECTRO 33UF	50WV	
C701			CE04LW1A221M	ELECTRO 220UF	10WV	
C702			CE04LW1H330M	ELECTRO 33UF	50WV	
C704			CE04LW1H470M	ELECTRO 47UF	50WV	
C705			CC73ECH1H150J	CHIP C 15PF	J	
C706			CC73ECH1H180J	CHIP C 18PF	J	
C707			CE04LW1H3R3M	ELECTRO 3.3UF	50WV	
C708			CE04LW1E470M	ELECTRO 47UF	25WV	
C709			CK73EB1H102K	CHIP C 1000PF	K	
C710			CC73ECH1H101J	CHIP C 100PF	J	
C711			CK73FB1E103K	CHIP C 0.010UF	K	
C712			CE04LW1V101M	ELECTRO 100UF	35WV	
C713			CE04LW1H220M	ELECTRO 22UF	50WV	
C715,716			CK73EB1H102K	CHIP C 1000PF	K	
C717			CE04LW1E470M	ELECTRO 47UF	25WV	
▲ C801			C91-1639-08	CERAMIC 4700PF	250V	
C802			CQ93FMG1H473J	MYLAR 0.047UF	J	
C803			CE04LW1V471M	ELECTRO 470UF	35WV	
C804			CE04LW1C100M	ELECTRO 10UF	16WV	
C805			CE04LW0J222M	ELECTRO 2200UF	6.3WV	
C809,810			CF92FV1H224J	MF-C 0.22UF	J	
C811,812			C92-0249-08	MYLAR 0.22UF	J	
C813,814			CF92FV1H224J	MF-C 0.22UF	J	
C815-817			CE04LW1H221M	ELECTRO 220UF	50WV	
C818,819			CE04LW1H470M	ELECTRO 47UF	50WV	
C820			CE04LW1V101M	ELECTRO 100UF	35WV	
C850			CE04LW1V222M	ELECTRO 2200UF	35WV	
C852			CQ93FMG1H473J	MYLAR 0.047UF	J	
C855			CQ93FMG1H104J	MYLAR 0.10UF	J	
C856			CK45FB1H101K	CERAMIC 100PF	K	
C859			CQ93FMG1H102J	MYLAR 1000PF	J	
C860			CE04KW1C682M	ELECTRO 6800UF	16WV	
C861			CK73EB1E223K	CHIP C 0.022UF	K	
C863,864			CE04LW1H220M	ELECTRO 22UF	50WV	
C865			CE04LW1E470M	ELECTRO 47UF	25WV	
C866			CK73EB1H102K	CHIP C 1000PF	K	

L : Scandinavia K : USA P : Canada R : Mexico C : China I : Malaysia  
Y : PX(Far East,Hawaii) T : England E : Europe G : Germany V : China(Shanghai)  
Y : AAFES(Europe) X : Australia Q : Russia H : Korea M : Other Areas ▲ indicates safety critical components .

\* New Parts  
Parts without **Parts No.** are not supplied.  
Les articles non mentionnés dans le **Parts No.** ne sont pas fournis.  
Teile ohne **Parts No.** werden nicht geliefert.

6

Ref. No	Add-ress	New Parts	Parts No.	Description	Desti-nation	Re-marks
C867			CE04LW1H010M	ELECTRO 1.0UF	50WV	
C901,902			C90-5727-08	ELECTRO 3300UF	63WV	5,6
C901,902			C91-1640-08	ELECTRO 3300UF	71WV	7
C903,904			C90-5728-08	ELECTRO 4700UF	35WV	
C905			CE04LW1H0R1M	ELECTRO 0.1UF	50WV	
C911-914			CC45FSL1H470J	CERAMIC 47PF	J	
C915,916			CE04LW1H470M	ELECTRO 47UF	50WV	
C917,918			CE04LW1HR33M	ELECTRO 0.33UF	50WV	
C919,920			CE04LW2A101M	ELECTRO 100UF	100WV	
C921,922			CE04LW1H101M	ELECTRO 100UF	50WV	
C923,924			CQ93FMG1H223J	MYLAR 0.022UF	J	
C925			CE04LW1H470M	ELECTRO 47UF	50WV	
C927-930			CQ93FMG1H104K	MYLAR 0.10UF	K	
C931-934			CQ93FMG1H223J	MYLAR 0.022UF	J	
C935-938			CF92FV1H104J	MF-C 0.10UF	J	
C939,940			CC45FSL1H221J	CERAMIC 220PF	J	
C943			CE04LW1H470M	ELECTRO 47UF	50WV	
C945			CE04LW1E470M	ELECTRO 47UF	25WV	
C946			CE04LW1A101M	ELECTRO 100UF	10WV	
C952			CE04LW1E221M	ELECTRO 220UF	25WV	
C956,957			CE04LW2A101M	ELECTRO 100UF	100WV	
C958			CE04LW1H0R1M	ELECTRO 0.1UF	50WV	
CE1			CE04LW1H010M	ELECTRO 1.0UF	50WV	
CK1			CK45FB1C103K	CERAMIC 0.010UF	K	
CK2			CF93AN1H474J	MF-C 0.47UF	J	
CK6			CF93AN1H104J	MF-C 0.10UF	J	
CK7			CF93AN1H474J	MF-C 0.47UF	J	
CK8			CE04LW1H4R7M	ELECTRO 4.7UF	50WV	
CK9			CE04LW1H2R2M	ELECTRO 2.2UF	50WV	
CK10 ,11			CF93AN1H104J	MF-C 0.10UF	J	
CK12			CE04LW1H2R2M	ELECTRO 2.2UF	50WV	
CK13			CK45FB1H472K	CERAMIC 4700PF	K	
CK14			CK45FB1C102K	CERAMIC 1000PF	K	
CK15			CF92FV1H683J	MF-C 0.068UF	J	
CK16			CF92FV1H224J	MF-C 0.22UF	J	
CK17			CE04LW1A221M	ELECTRO 220UF	10WV	
CK18			CE04LW1C101M	ELECTRO 100UF	16WV	
CK19			CK45FB1H223Z	CERAMIC 0.022UF	Z	
CK20			CF93AN2A224K	MF-C 0.22UF	K	
CK21			CF92FV1H683J	MF-C 0.068UF	J	
CK22			CK45FB1H472K	CERAMIC 4700PF	K	
CK23			CK45FB1H102K	CERAMIC 1000PF	K	
CK24 -26			CE04LW1H2R2M	ELECTRO 2.2UF	50WV	
CK27 ,28			CC45FCH1H101J	CERAMIC 100PF	J	
CK29 ,30			CE04LW1H2R2M	ELECTRO 2.2UF	50WV	
CK31			CF93AN1H154J	MF-C 0.15UF	J	
CK33 -35			CC45FCH1H470J	CERAMIC 47PF	J	
CK43 ,44			CE04LW1E470M	ELECTRO 47UF	25WV	
CK45 ,46			CE04LW1H2R2M	ELECTRO 2.2UF	50WV	
CK47 ,48			CC45FCH1H221J	CERAMIC 220PF	J	
CK49 ,50			CC45FCH1H101J	CERAMIC 100PF	J	
CK51 ,52			CE04LW1H4R7M	ELECTRO 4.7UF	50WV	
CK53			CE04LW1H470M	ELECTRO 47UF	50WV	
CK54			CE04LW1C101M	ELECTRO 100UF	16WV	
CM1			CE04LW0J102M	ELECTRO 1000UF	6.3WV	

L : Scandinavia K : USA P : Canada R : Mexico C : China I : Malaysia  
Y : PX(Far East,Hawaii) T : England E : Europe G : Germany V : China(Shanghai)  
Y : AAFES(Europe) X : Australia Q : Russia H : Korea M : Other Areas ▲ indicates safety critical components .

PARTS LIST

RXD-V555/V757

\* New Parts  
Parts without **Parts No.** are not supplied.  
Les articles non mentionnés dans le **Parts No.** ne sont pas fournis.  
Teile ohne **Parts No.** werden nicht geliefert.

7

Ref. No	Add-ress	New Parts	Parts No.	Description	Desti-nation	Re-marks
CM2			CE04LW1C100M	ELECTRO 10UF 16WV		
CM5			CE04LW1A101M	ELECTRO 100UF 10WV		
CM6			CK73GB1C104K	CHIP C 0.10UF K		
CM7			CE04LW1C101M	ELECTRO 100UF 16WV		
CM8 ,9			CK73GB1C104K	CHIP C 0.10UF K		
CM11 ,12			CC73GCH1H270J	CHIP C 27PF J		
CM13			CK73GB1H102K	CHIP C 1000PF K		
CM14			CK73GB1C104K	CHIP C 0.10UF K		
CM15			CC73GCH1H220J	CHIP C 22PF J		
CM16			CK73GB1C104K	CHIP C 0.10UF K		
CM17			CK73GB1C104K	CHIP C 0.10UF K		
CM18			CK73GB1C104K	CHIP C 0.10UF K		
CM19 ,20			CK73GB1C104K	CHIP C 0.10UF K		
CM21			CE04LW1A101M	ELECTRO 100UF 10WV		
CM22			CC73GCH1H100D	CHIP C 10PF D		
CM23			CK73GB1C104K	CHIP C 0.10UF K		
CM24			CE04LW1A101M	ELECTRO 100UF 10WV		
CM25			CK73GB1C104K	CHIP C 0.10UF K		
CM26			CK73GB1E223K	CHIP C 0.022UF K		
CM27			CE04LW1C100M	ELECTRO 10UF 16WV		
CM28			CK73GB1E223K	CHIP C 0.022UF K		
CM29			CK73GB1E223K	CHIP C 0.022UF K		
CM30			CK73GB1C104K	CHIP C 0.10UF K		
CM31			CK73GB1E223K	CHIP C 0.022UF K		
CM32			CE04LW1A101M	ELECTRO 100UF 10WV		
CM33			CK73GB1E223K	CHIP C 0.022UF K		
CM34			CE04LW1C100M	ELECTRO 10UF 16WV		
CM35			CK73GB1E223K	CHIP C 0.022UF K		
CM36			CE04LW1A101M	ELECTRO 100UF 10WV		
CM37			CK73GB1C104K	CHIP C 0.10UF K		
CM38			CE04LW1C100M	ELECTRO 10UF 16WV		
CM39			CK73GB1C104K	CHIP C 0.10UF K		
CM40			CK73GB1C103K	CHIP C 0.010UF K		
CM41 -44			CE04LW1C100M	ELECTRO 10UF 16WV		
CM45			CE04LW1A101M	ELECTRO 100UF 10WV		
CM46			CC73GCH1H330J	CHIP C 33PF J		
CM47			CK73GB1C104K	CHIP C 0.10UF K		
CM48			CE04LW1A101M	ELECTRO 100UF 10WV		
CM49			CC73GCH1H330J	CHIP C 33PF J		
CM50			CC73GCH1H470J	CHIP C 47PF J		
CM51			CC73GCH1H221J	CHIP C 220PF J		
CM52 ,53			CE04LW1C100M	ELECTRO 10UF 16WV		
CM54 ,55			CC73GCH1H220J	CHIP C 22PF J		
CM56 ,57			CE04LW1C100M	ELECTRO 10UF 16WV		
CV601			CK45FB1H223K	CERAMIC 0.022UF K		
VD301			C02-0303-08	VARICAP(AM) VHCSVC348S/-1T		
VD302,303			C02-0302-08	VARICAP(FM) VHCSVC211C/-1T		
BI8			E40-8932-08	FLAT CABLE CON QCNWN1923AWZZ		
BI11			E35-3002-08	WIRE HARNESS QCNWN1924AWZZ		
BI902			E35-2993-08	WIRE HARNESS QCNWN1916AWZZ		
BI903			E35-2994-08	WIRE HARNESS(8P) QCNWN1917AWZZ		
BI905			E35-2997-08	WIRE HARNESS QCNWN1919AWZZ		
CNP101			E40-8264-08	PIN ASSY QCNM705CAFZZ		
CNP301			E40-8933-08	PIN ASSY(AM) CONE2P5268		

L : Scandinavia K : USA P : Canada R : Mexico C : China I : Malaysia  
Y : PX(Far East,Hawaii) T : England E : Europe G : Germany V : China(Shanghai)  
Y : AAFES(Europe) X : Australia Q : Russia H : Korea M : Other Areas  $\Delta$  indicates safety critical components .

\* New Parts  
Parts without **Parts No.** are not supplied.  
Les articles non mentionnés dans le **Parts No.** ne sont pas fournis.  
Teile ohne **Parts No.** werden nicht geliefert.

8

Ref. No	Add-ress	New Parts	Parts No.	Description	Desti-nation	Re-marks
CNP701			E35-3000-08	PIN ASSY QCNWZX20AWZZ		
CNS701			E40-8930-08	PIN ASSY(FFC) QCNWZY20AWZZ		
CNS702			E40-8929-08	PIN ASSY(FFC) QCNWZY10AWZZ		
CNP901			E40-8926-08	PIN ASSY QCNM010NAWZZ		
CNP902			E40-8924-08	PIN ASSY CONE5P5267X		
CNP903			E40-8935-08	PIN ASSY CONE8P5267		
CNP904			E40-8923-08	PIN ASSY CONE2P53253		
CNP905			E40-8381-08	PIN ASSY CONE6P53253		
CNS901			E35-2999-08	WIRE HARNESS QCNW010NAWZZ		
FW701			E35-2998-08	WIRE HARNESS(3P) QCNWN1922AWZZ		
FW701A/B			E40-8931-08	WIRE HARNESS QCNW015CAWZZ		
FW801			E35-2995-08	WIRE HARNESS(4P) QCNWN1918AWZZ		
FW801A			E40-8928-08	WIRE HARNESS QCNW015DAWZZ		
FW801B			E40-8928-08	WIRE HARNESS QCNW015DAWZZ		
FW902		*	QCNWN2051AWZZ	FLAT WIRE 5PIN QCNWN2051AWZZ		
FW902A			E40-8927-08	CONNECTOR QCNW019EAWZZ		
JK1		*	E11-0953-08	JACK,MIC QJAKJ0010AWZZ		
JK601			E63-1219-08	PIN JACK QSOCJ0224AWZZ		
JK670			E11-0942-08	PHONE JACK QJAKM0004AWZZ		
JK671		*	E02-0021-08	VIDEO OUT SKT QSOCJ0110AWZZ		
SO301			E70-0145-08	FM ANT QTANC0105AWZZ		
SO901			E70-0144-08	LOCK TERMINAL QTANA0415AWZZ		
WT601			E40-8934-08	PIN ASSY QCNW012EAWZZ		
$\Delta$ F801			F50-0202-08	FUSE(T5AL250V) QFS-D502CAWNI		
$\Delta$ F802,803			F50-0201-08	FUSE(T2.5AL250V) QFS-D252CAWNI		
$\Delta$ F804,805			F50-0202-08	FUSE(T5AL250V) QFS-D502CAWNI		
$\Delta$ F806,807			F50-0199-08	FUSE(T2AL250V) QFS-D202CAWNI		
-			J19-6237-08	HOLDER(FL) LHLDZ1338AWSA		
FH801,802			J19-6238-08	HOLDER(FUSE) QFSDH0001AWZZT		
FH803-806			J19-6238-08	HOLDER(FUSE) QFSDH0001AWZZT		
FH807-814			J19-6238-08	HOLDER(FUSE) QFSDH0001AWZZT		
BF301			L32-1040-08	FM BPF RFILR0008AWZZT		
CF303			L72-0638-08	CERAMIC FILTER RFILF0124AFZZ		
CF351			L79-1287-08	FM DETECTOR 10 RFILF0003AFWZZ		
CF352			L79-1286-08	AM FILTER RFILA0009AWZZ		
L61		*	L90-0396-08	COIL RCILC0011AWZZT		
L62		*	L90-0397-08	COIL RCILC0012AWZZT		
L104			L90-0389-08	COIL VP-MK331K0000T		
L312			L90-0391-08	COIL RCILR0056AWZZ		
L351,352			L90-0388-08	COIL VP-DH101K0000T		
L700			L90-0388-08	COIL VP-DH101K0000T		
L901,902			L39-1342-08	COIL RCILZ0137AFZZ		
LM1 -3		*	L90-0398-08	COIL RCILC0013AWZZT		
T301			L33-1634-08	CHOKE COIL RCILB0065AWZZ		
T302			L31-0662-08	FM-RF COIL RCIL10017AWZZ		
T303			L31-0661-08	FM-RF COIL RCILA0052AWZZ		
T306			L32-1039-08	OSC COIL(AM) RCILB0067AWZZ		
T351			L30-0985-08	IFT COIL(AM) RCIL10019AWZZ		
T802			L07-3152-08	TRANSFORMER RTRNP0341AWZZ		
X351			L77-2351-08	CRYSTAL RESONA CRSTL1425A		
X352			L77-2352-08	CRYSTAL RESONA RCRSP0019AWZZ		
XL1		*	L77-2390-08	RESONATOR RCRSP0013AWZZ		
XL1		*	L77-2390-08	RESONATOR RCRSP0013AWZZ		
XL2		*	L77-2391-08	CRYSTAL,16.93 RCRSP0016AWZZ		

L : Scandinavia K : USA P : Canada R : Mexico C : China I : Malaysia  
Y : PX(Far East,Hawaii) T : England E : Europe G : Germany V : China(Shanghai)  
Y : AAFES(Europe) X : Australia Q : Russia H : Korea M : Other Areas  $\Delta$  indicates safety critical components .

\* New Parts

Parts without **Parts No.** are not supplied.

Les articles non mentionnés dans le **Parts No.** ne sont pas fournis.

Teile ohne **Parts No.** werden nicht geliefert.

9

Ref. No	Add-ress	New Parts	Parts No.	Description	Desti-nation	Re-marks
XL700			L77-2230-08	CRYSTAL RESONA RCRSP0003AWZZ		
L1M1 ,2			RK73FB2A000J	CHIP R 0 J 1/10W		
MJ1 -7			RK73EB2B000J	CHIP R 0 J 1/8W		
MJ101			RK73EB2B000J	CHIP R 0 J 1/8W		
MJ306			RK73EB2B000J	CHIP R 0 J 1/8W		
MJ307,308			RK73EB2B000J	CHIP R 0 J 1/8W		
MJ309,310			RK73EB2B000J	CHIP R 0 J 1/8W		
MJ314			RK73EB2B000J	CHIP R 0 J 1/8W		
R3			RK73GB1J473J	CHIP R 47K J 1/16W		
R4			RK73GB1J103J	CHIP R 10K J 1/16W		
R5			RK73GB1J393J	CHIP R 39K J 1/16W		
R6			RK73GB1J273J	CHIP R 27K J 1/16W		
R7			RK73GB1J682J	CHIP R 6.8K J 1/16W		
R8			RK73GB1J331J	CHIP R 330 J 1/16W		
R10			RK73GB1J273J	CHIP R 27K J 1/16W		
R11			RK73GB1J123J	CHIP R 12K J 1/16W		
R12 ,13			RK73GB1J681J	CHIP R 680 J 1/16W		
R14			RK73GB1J122J	CHIP R 1.2K J 1/16W		
R15			RK73GB1J103J	CHIP R 10K J 1/16W		
R16			RK73GB1J103J	CHIP R 10K J 1/16W		
R17			RK73GB1J103J	CHIP R 10K J 1/16W		
R20			RK73GB1J221J	CHIP R 220 J 1/16W		
R21 ,22			RK73GB1J471J	CHIP R 470 J 1/16W		
R25			RK73GB1J103J	CHIP R 10K J 1/16W		
R35			RK73GB1J102J	CHIP R 1.0K J 1/16W		
R37			RK73GB1J152J	CHIP R 1.5K J 1/16W		
R38			RK73GB1J271J	CHIP R 270 J 1/16W		
R39			RK73GB1J471J	CHIP R 470 J 1/16W		
R40			RK73GB1J122J	CHIP R 1.2K J 1/16W		
R42			RK73GB1J563J	CHIP R 56K J 1/16W		
R44			RK73GB1J102J	CHIP R 1.0K J 1/16W		
R45			RK73GB1J122J	CHIP R 1.2K J 1/16W		
R46			RK73GB1J102J	CHIP R 1.0K J 1/16W		
R47			RK73GB1J3R0J	CHIP R 3 J 1/16W		
R48			RK73GB1J682J	CHIP R 6.8K J 1/16W		
R50			RK73GB1J470J	CHIP R 47 J 1/16W		
R51			RK73GB1J683J	CHIP R 68K J 1/16W		
R52 ,53			RK73GB1J563J	CHIP R 56K J 1/16W		
R54			RK73GB1J683J	CHIP R 68K J 1/16W		
R55 ,56			RK73GB1J563J	CHIP R 56K J 1/16W		
R58			RK73GB1J680J	CHIP R 68 J 1/16W		
R67 ,68			RK73GB1J102J	CHIP R 1.0K J 1/16W		
R71			RK73GB1J102J	CHIP R 1.0K J 1/16W		
R72 ,73			RK73GB1J102J	CHIP R 1.0K J 1/16W		
R75			RK73GB1J101J	CHIP R 100 J 1/16W		
R76 -78			RK73GB1J102J	CHIP R 1.0K J 1/16W		
R79			RK73GB1J155J	CHIP R 1.5M J 1/16W		
R80			RK73GB1J105J	CHIP R 1.0M J 1/16W		
R86			RK73GB1J000J	CHIP R 0 J 1/16W		
R92 ,93			RK73GB1J000J	CHIP R 0 J 1/16W		
R94			RK73GB1J103J	CHIP R 10K J 1/16W		
R95			RK73GB1J103J	CHIP R 10K J 1/16W		
R97			RK73GB1J392J	CHIP R 3.9K J 1/16W		
R101			RK73EB2B102J	CHIP R 1.0K J 1/8W		

L : Scandinavia K : USA P : Canada R : Mexico C : China I : Malaysia  
 Y : PX(Far East,Hawaii) T : England E : Europe G : Germany V : China(Shanghai)  
 Y : AAFES(Europe) X : Australia Q : Russia H : Korea M : Other Areas  $\Delta$  indicates safety critical components.

\* New Parts

Parts without **Parts No.** are not supplied.

Les articles non mentionnés dans le **Parts No.** ne sont pas fournis.

Teile ohne **Parts No.** werden nicht geliefert.

10

Ref. No	Add-ress	New Parts	Parts No.	Description	Desti-nation	Re-marks
R103,104			RK73EB2B222J	CHIP R 2.2K J 1/8W		
R105,106			RK73EB2B332J	CHIP R 3.3K J 1/8W		
R107,108			RK73EB2B473J	CHIP R 47K J 1/8W		
R109,110			RK73EB2B472J	CHIP R 4.7K J 1/8W		
R110,111			RK73GB1J000J	CHIP R 0 J 1/16W		
R112			RK73EB2B153J	CHIP R 15K J 1/8W		
R112			RK73GB1J331J	CHIP R 330 J 1/16W		
R113			RK73GB1J222J	CHIP R 2.2K J 1/16W		
R113,114			RK73EB2B103J	CHIP R 10K J 1/8W		
R114			RK73GB1J223J	CHIP R 22K J 1/16W		
R115			RK73EB2B472J	CHIP R 4.7K J 1/8W		
R115			RK73GB1J000J	CHIP R 0 J 1/16W		
R116			RK73GB1J152J	CHIP R 1.5K J 1/16W		
R117			RK73GB1J331J	CHIP R 330 J 1/16W		
R118			RK73GB1J222J	CHIP R 2.2K J 1/16W		
R120			RK73EB2B560J	CHIP R 56 J 1/8W		
R121,122			RK73EB2B104J	CHIP R 100K J 1/8W		
R123,124			RK73EB2B392J	CHIP R 3.9K J 1/8W		
R125,126			RK73EB2B562J	CHIP R 5.6K J 1/8W		
R131,132			RK73EB2B392J	CHIP R 3.9K J 1/8W		
R134			RK73EB2B683J	CHIP R 68K J 1/8W		
R135,136			RK73EB2B472J	CHIP R 4.7K J 1/8W		
R137,138			RK73EB2B682J	CHIP R 6.8K J 1/8W		
R139,140			RK73EB2B102J	CHIP R 1.0K J 1/8W		
R141,142			RK73EB2B101J	CHIP R 100 J 1/8W		
R145,146			RK73EB2B103J	CHIP R 10K J 1/8W		
R153			RK73EB2B103J	CHIP R 10K J 1/8W		
R156			RK73EB2B224J	CHIP R 220K J 1/8W		
R160			RN14BK2H82ROF	RN 82 F 1/2W		
R162			RK73EB2B473J	CHIP R 47K J 1/8W		
R166			RK73EB2B223J	CHIP R 22K J 1/8W		
R167			RK73EB2B473J	CHIP R 47K J 1/8W		
R169-174			RK73EB2B102J	CHIP R 1.0K J 1/8W		
R302			RK73EB2B100J	CHIP R 10 J 1/8W		
R311			RK73EB2B104J	CHIP R 100K J 1/8W		
R313			RK73EB2B333J	CHIP R 33K J 1/8W		
R316			RK73EB2B472J	CHIP R 4.7K J 1/8W		
R322			RK73EB2B681J	CHIP R 680 J 1/8W		
R323			RK73EB2B683J	CHIP R 68K J 1/8W		
R325			RK73EB2B473J	CHIP R 47K J 1/8W		
R327			RK73EB2B330J	CHIP R 33 J 1/8W		
R336			RK73EB2B103J	CHIP R 10K J 1/8W		
R350			RK73EB2B272J	CHIP R 2.7K J 1/8W		
R351			RK73EB2B562J	CHIP R 5.6K J 1/8W		
R352			RK73EB2B102J	CHIP R 1.0K J 1/8W		
R353			RK73EB2B271J	CHIP R 270 J 1/8W		
R355			RK73EB2B332J	CHIP R 3.3K J 1/8W		
R356			RK73EB2B102J	CHIP R 1.0K J 1/8W		
R359			RK73EB2B182J	CHIP R 1.8K J 1/8W		
R360			RK73EB2B472J	CHIP R 4.7K J 1/8W		
R361,362			RK73EB2B332J	CHIP R 3.3K J 1/8W		
R365			RK73EB2B103J	CHIP R 10K J 1/8W		
R372-374			RK73EB2B102J	CHIP R 1.0K J 1/8W		
R376			RK73EB2B102J	CHIP R 1.0K J 1/8W		
R377			RK73EB2B473J	CHIP R 47K J 1/8W		

L : Scandinavia K : USA P : Canada R : Mexico C : China I : Malaysia  
 Y : PX(Far East,Hawaii) T : England E : Europe G : Germany V : China(Shanghai)  
 Y : AAFES(Europe) X : Australia Q : Russia H : Korea M : Other Areas  $\Delta$  indicates safety critical components.

PARTS LIST

RXD-V555/V757

\* New Parts

Parts without **Parts No.** are not supplied.Les articles non mentionnés dans le **Parts No.** ne sont pas fournis.Teile ohne **Parts No.** werden nicht geliefert.

11

Ref. No	Add-ress	New Parts	Parts No.	Description	Desti-nation	Re-marks
R378			RK73EB2B102J	CHIP R	1.0K	J 1/8W
R379			RK73EB2B222J	CHIP R	2.2K	J 1/8W
R380			RK73EB2B152J	CHIP R	1.5K	J 1/8W
R381			RK73EB2B103J	CHIP R	10K	J 1/8W
R383			RK73EB2B562J	CHIP R	5.6K	J 1/8W
R385			RK73EB2B562J	CHIP R	5.6K	J 1/8W
R388			RK73EB2B392J	CHIP R	3.9K	J 1/8W
R393			RK73EB2B102J	CHIP R	1.0K	J 1/8W
R395			RK73EB2B473J	CHIP R	47K	J 1/8W
R561			RK73EB2B103J	CHIP R	10K	J 1/8W
R562			RK73EB2B824J	CHIP R	820K	J 1/8W
R565			RK73EB2B333J	CHIP R	33K	J 1/8W
R566			RK73EB2B224J	CHIP R	220K	J 1/8W
R567			RK73EB2B683J	CHIP R	68K	J 1/8W
R568			RK73EB2B224J	CHIP R	220K	J 1/8W
R569			RK73EB2B104J	CHIP R	100K	J 1/8W
R570			RK73EB2B123J	CHIP R	12K	J 1/8W
R571			RK73EB2B394J	CHIP R	390K	J 1/8W
R572			RK73EB2B104J	CHIP R	100K	J 1/8W
R573			RK73EB2B563J	CHIP R	56K	J 1/8W
R574			RK73EB2B105J	CHIP R	1.0M	J 1/8W
R575			RK73EB2B474J	CHIP R	470K	J 1/8W
R576			RK73EB2B225J	CHIP R	2.2M	J 1/8W
R577			RK73EB2B154J	CHIP R	150K	J 1/8W
R578			RK73EB2B104J	CHIP R	100K	J 1/8W
R580			RK73EB2B184J	CHIP R	180K	J 1/8W
R605,606			RK73EB2B562J	CHIP R	5.6K	J 1/8W
R607,608			RK73EB2B103J	CHIP R	10K	J 1/8W
R611,612			RK73EB2B332J	CHIP R	3.3K	J 1/8W
R613,614			RK73EB2B331J	CHIP R	330	J 1/8W
R615,616			RK73EB2B222J	CHIP R	2.2K	J 1/8W
R617,618			RK73EB2B103J	CHIP R	10K	J 1/8W
R619,620			RK73EB2B223J	CHIP R	22K	J 1/8W
R621,622			RK73EB2B222J	CHIP R	2.2K	J 1/8W
R631,632			RK73EB2B103J	CHIP R	10K	J 1/8W
R633,634			RK73EB2B563J	CHIP R	56K	J 1/8W
R637,638			RK73EB2B474J	CHIP R	470K	J 1/8W
R700			RK73EB2B101J	CHIP R	100	J 1/8W
R704-706			RK73EB2B102J	CHIP R	1.0K	J 1/8W
R731			RK73EB2B103J	CHIP R	10K	J 1/8W
R739-745			RK73EB2B102J	CHIP R	1.0K	J 1/8W
R747			RK73EB2B101J	CHIP R	100	J 1/8W
R750			RK73EB2B225J	CHIP R	2.2M	J 1/8W
R752			RK73EB2B103J	CHIP R	10K	J 1/8W
R756-759			RK73EB2B103J	CHIP R	10K	J 1/8W
R760			RK73EB2B104J	CHIP R	100K	J 1/8W
R761			RK73EB2B102J	CHIP R	1.0K	J 1/8W
R762			RK73EB2B104J	CHIP R	100K	J 1/8W
R763			RK73EB2B102J	CHIP R	1.0K	J 1/8W
R764			RK73EB2B104J	CHIP R	100K	J 1/8W
R765			RK73EB2B102J	CHIP R	1.0K	J 1/8W
R766-770			RK73EB2B103J	CHIP R	10K	J 1/8W
R771			RK73EB2B103J	CHIP R	10K	J 1/8W
R772			RK73EB2B103J	CHIP R	10K	J 1/8W
R773			RK73EB2B102J	CHIP R	1.0K	J 1/8W

L : Scandinavia K : USA P : Canada R : Mexico C : China I : Malaysia  
 Y : PX(Far East,Hawaii) T : England E : Europe G : Germany V : China(Shanghai)  
 Y : AAFES(Europe) X : Australia Q : Russia H : Korea M : Other Areas  $\Delta$  indicates safety critical components.

\* New Parts

Parts without **Parts No.** are not supplied.Les articles non mentionnés dans le **Parts No.** ne sont pas fournis.Teile ohne **Parts No.** werden nicht geliefert.

12

Ref. No	Add-ress	New Parts	Parts No.	Description	Desti-nation	Re-marks
R774			RK73EB2B103J	CHIP R	10K	J 1/8W
R776-780			RK73EB2B103J	CHIP R	10K	J 1/8W
R783			RK73EB2B473J	CHIP R	47K	J 1/8W
R787			RK73EB2B102J	CHIP R	1.0K	J 1/8W
R790			RK73EB2B000J	CHIP R	0	J 1/8W
R855			RD14BB2H3R3J	RD	3.3	J 1/2W
R861			RK73EB2B683J	CHIP R	68K	J 1/8W
R863			RK73EB2B333J	CHIP R	33K	J 1/8W
R868,869			RK73EB2B562J	CHIP R	5.6K	J 1/8W
R870			RK73EB2B222J	CHIP R	2.2K	J 1/8W
R873			RK73EB2B102J	CHIP R	1.0K	J 1/8W
R874,875			RK73EB2B104J	CHIP R	100K	J 1/8W
R878,879			RK73EB2B223J	CHIP R	22K	J 1/8W
R880			RK73EB2B103J	CHIP R	10K	J 1/8W
R911,912			R92-4565-08	FUSE R	100	J 1/4W
R913-916			R92-4566-08	FL-PROOF RS	0.22	J 3W
R917,918			R92-4567-08	FL-PROOF RS	0.1	J 3W
R924			RD14BB2H4R7J	RD	4.7	J 1/2W
R925-928			RD14BB2H100J	RD	10	J 1/2W
R931,932			RD14BB2H100J	RD	10	J 1/2W
R941,942			RS14AB3D561J	FL-PROOF RS	560	J 2W
R943			RS14AB3D681J	FL-PROOF RS	680	J 2W
R945,946			RD14BB2H3R9J	RD	3.9	J 1/2W
R947,948			RD14BB2H3R9J	RD	3.9	J 1/2W
R953,954			RD14BB2H100J	RD	10	J 1/2W
RD01			RK73EB2B681J	CHIP R	680	J 1/8W
RD02			RK73EB2B821J	CHIP R	820	J 1/8W
RD04			RK73EB2B681J	CHIP R	680	J 1/8W
RD05			RK73EB2B821J	CHIP R	820	J 1/8W
RD06			RK73EB2B102J	CHIP R	1.0K	J 1/8W
RD07			RK73EB2B152J	CHIP R	1.5K	J 1/8W
RD08			RK73EB2B222J	CHIP R	2.2K	J 1/8W
RD09			RK73EB2B681J	CHIP R	680	J 1/8W
RD10			RK73EB2B821J	CHIP R	820	J 1/8W
RD11			RK73EB2B102J	CHIP R	1.0K	J 1/8W
RD12			RK73EB2B152J	CHIP R	1.5K	J 1/8W
RD13			RK73EB2B222J	CHIP R	2.2K	J 1/8W
RD15			RK73EB2B392J	CHIP R	3.9K	J 1/8W
RD16			RK73EB2B562J	CHIP R	5.6K	J 1/8W
RD17			RK73EB2B103J	CHIP R	10K	J 1/8W
RD18			RK73EB2B183J	CHIP R	18K	J 1/8W
RK14,15			RD14BB2H101J	RD	100	J 1/2W
RM1-8			RK73GB1J330J	CHIP R	33	J 1/16W
RM9			RK73GB1J151J	CHIP R	150	J 1/16W
RM10			RK73GB1J221J	CHIP R	220	J 1/16W
RM11			RK73GB1J151J	CHIP R	150	J 1/16W
RM12,13			RK73GB1J151J	CHIP R	150	J 1/16W
RM14			RK73GB1J104J	CHIP R	100K	J 1/16W
RM15,16			RK73GB1J472J	CHIP R	4.7K	J 1/16W
RM17-19			RK73GB1J000J	CHIP R	0	J 1/16W
RM20			RK73GB1J000J	CHIP R	0	J 1/16W
RM21			RK73GB1J223J	CHIP R	22K	J 1/16W
RM22			RK73GB1J000J	CHIP R	0	J 1/16W
RM23			RK73GB1J472J	CHIP R	4.7K	J 1/16W
RM24			RK73GB1J103J	CHIP R	10K	J 1/16W

L : Scandinavia K : USA P : Canada R : Mexico C : China I : Malaysia  
 Y : PX(Far East,Hawaii) T : England E : Europe G : Germany V : China(Shanghai)  
 Y : AAFES(Europe) X : Australia Q : Russia H : Korea M : Other Areas  $\Delta$  indicates safety critical components.

PARTS LIST

RXD-V555/W757



\* New Parts  
 Parts without **Parts No.** are not supplied.  
 Les articles non mentionnés dans le **Parts No.** ne sont pas fournis.  
 Teile ohne **Parts No.** werden nicht geliefert.

13

Ref. No	Add-ress	New Parts	Parts No.	Description	Desti-nation	Re-marks
RM25			RK73GB1J103J	CHIP R 10K J 1/16W		
RM26 ,27			RK73GB1J472J	CHIP R 4.7K J 1/16W		
RM28			RK73GB1J000J	CHIP R 0 J 1/16W		
RM30 ,31			RK73GB1J330J	CHIP R 33 J 1/16W		
RM32			RK73GB1J100J	CHIP R 10 J 1/16W		
RM33			RK73GB1J330J	CHIP R 33 J 1/16W		
RM34			RK73GB1J103J	CHIP R 10K J 1/16W		
RM35			RK73GB1J101J	CHIP R 100 J 1/16W		
RM36			RK73GB1J102J	CHIP R 1.0K J 1/16W		
RM37			RK73GB1J000J	CHIP R 0 J 1/16W		
RM38			RK73GB1J330J	CHIP R 33 J 1/16W		
RM39			RK73GB1J000J	CHIP R 0 J 1/16W		
RM40			RK73GB1J000J	CHIP R 0 J 1/16W		
RM41			RK73GB1J822J	CHIP R 8.2K J 1/16W		
RM42 -44			RK73GB1J330J	CHIP R 33 J 1/16W		
RM45			RK73GB1J472J	CHIP R 4.7K J 1/16W		
RM47			RK73GB1J102J	CHIP R 1.0K J 1/16W		
RM49			RK73GB1J472J	CHIP R 4.7K J 1/16W		
RM50			RK73GB1J470J	CHIP R 47 J 1/16W		
RM51 ,52			RK73GB1J103J	CHIP R 10K J 1/16W		
RM53 ,54			RK73GB1J104J	CHIP R 100K J 1/16W		
RM55			RK73GB1J682J	CHIP R 6.8K J 1/16W		
RM56 ,57			RK73GB1J104J	CHIP R 100K J 1/16W		
RM58			RK73GB1J103J	CHIP R 10K J 1/16W		
RM59			RK73GB1J103J	CHIP R 10K J 1/16W		
RM60 -62			RK73GB1J103J	CHIP R 10K J 1/16W		
RM63			RK73GB1J223J	CHIP R 22K J 1/16W		
RM64			RK73GB1J223J	CHIP R 22K J 1/16W		
RM65 ,66			RK73GB1J102J	CHIP R 1.0K J 1/16W		
RM67 ,68			RK73GB1J104J	CHIP R 100K J 1/16W		
RM69			RK73GB1J682J	CHIP R 6.8K J 1/16W		
RM70			RK73GB1J221J	CHIP R 220 J 1/16W		
RM71			RK73GB1J123J	CHIP R 12K J 1/16W		
RM72			RK73GB1J221J	CHIP R 220 J 1/16W		
RM73			RK73GB1J222J	CHIP R 2.2K J 1/16W		
RM74 ,75			RK73GB1J221J	CHIP R 220 J 1/16W		
RM76			RK73GB1J560J	CHIP R 56 J 1/16W		
RM77 ,78			RK73GB1J472J	CHIP R 4.7K J 1/16W		
RM79			RK73GB1J000J	CHIP R 0 J 1/16W		
RM80			RK73GB1J102J	CHIP R 1.0K J 1/16W		
VRK1		*	R92-4579-08	MIC VOLUME VRR1674A		
VR701			R32-0106-08	VR(JOG) QSW-Z0013AWZZ		
RL801	Δ		S76-0124-08	MAGNETIC RELAY RRLYD0012AWZZ		
RL901			S76-0125-08	MAGNETIC RELAY RRLYD0014AWZZ		
SW1			S68-0139-08	PUSH SWITCH SWMPU10780MLB		
SW2 ,3			S68-0140-08	PUSH SWITCH SWMPU11470MLB		
SW4			S68-0138-08	PUSH SWITCH QSWF9001AW01		
SW601			S62-0086-08	SWITCH QSW-S0024AWZZ		
SW701-721			S70-0091-08	TACT SWITCH SWICH1401AT		
SW801	Δ		S62-0106-08	SLIDE SW QSOCE0008AWZZ		
D21 ,22		*	VHDKDS193// -1+	SEMICONDUCTOR VHDKDS193// -1+		
D301-305			1SS133	DIODE VHDDS1SS133-1T		
D513-516			1SS133	DIODE VHDDS1SS133-1T		
D701			1SS133	DIODE VHDDS1SS133-1T		

L : Scandinavia K : USA P : Canada R : Mexico C : China I : Malaysia  
 Y : PX(Far East,Hawaii) T : England E : Europe G : Germany V : China(Shanghai)  
 Y : AAFES(Europe) X : Australia Q : Russia H : Korea M : Other Areas Δ indicates safety critical components .

\* New Parts  
 Parts without **Parts No.** are not supplied.  
 Les articles non mentionnés dans le **Parts No.** ne sont pas fournis.  
 Teile ohne **Parts No.** werden nicht geliefert.

14

Ref. No	Add-ress	New Parts	Parts No.	Description	Desti-nation	Re-marks
D702,703			1SS133	DIODE VHDDS1SS133-1T		5,6
D706-711			1SS133	DIODE VHDDS1SS133-1T		
D717,718			1SS133	DIODE VHDDS1SS133-1T		
D801			1SS133	DIODE VHDDS1SS133-1T		
Δ D802-805			1N4004S	DIODE VHDDS1N4004S-1T		
D806-808			1SS133	DIODE VHDDS1SS133-1T		
Δ D809			D3SBA60F	DIODE VHDD3SBA60F-1		5,6
Δ D809			TS6B04GM	DIODE VHDTS6B04GM-1		7
Δ D810			D10XB60F	DIODE VHDD10XB60F-1		7
Δ D810			TS6B04GM	DIODE VHDTS6B04GM-1		5,6
Δ D811-816			1N4004S	DIODE VHDDS1N4004S-1T		
D818			1N4004S	DIODE VHDDS1N4004S-1T		
D850,851			1SS133	DIODE VHDDS1SS133-1T		
D861,862			1SS133	DIODE VHDDS1SS133-1T		
D901,902			1N4004S	DIODE VHDDS1N4004S-1T		
D907-909			1SS133	DIODE VHDDS1SS133-1T		
D911-913			1SS133	DIODE VHDDS1SS133-1T		
DM1		*	VHDKDS193// -1+	SEMICONDUCTOR VHDKDS193// -1+		
DV601,602			1SS133	DIODE VHDDS1SS133-1T		
ICK1		*	M65856SP	IC VHM65856SP-1		
ICM1		*	1625635T	IC VHI1625635T-1		
IC1		*	LA9235M	IC VHILA9235M/-1		
ICK2		*	KIA4558P	IC		
ICM2		*	ES3880F	IC VHIES3880F/-1		
IC2		*	LC78636E	IC VHILC78636E-1		
ICM3		*	ES3889F	IC VHIES3889F/-1		
IC3		*	M63001FP	IC VHM63001FP		
ICM4		*	IX0455	IC RH-IX0455AW00		
IC6			BA4558F	IC(OP AMP X2)		
IC101			AN7345K	MOS-IC VHIAN7345K/-1		
IC301			TA7358AP	ANALOGUE IC VHITA7358AP-1		
IC302			LC72131	MOS-IC VHILC72131/-1		
IC303			LA1832S	MOS-IC VHILA1832S/-1		
IC561,562			KIA4558P	ANALOGUE IC VHIKIA4558P-1		
IC601			LC75341	MOS-IC VHILC75341/-1		
IC700		*	IX0415	MI-COM IC RH-IX0415AWZZ		
IC860			KIA4558P	ANALOGUE IC VHIKIA4558P-1		
IC901			STK41203	IC VHISTK41203-1		
IC901			STK4121J	IC VHISTK4121J-1		
Q2			KRC102S	TRANSISTOR		
Q3			KTA1504Y	TRANSISTOR		
Q4			KTC3203Y	TRANSISTOR		
Q9 ,10			KTC3875Y	TRANSISTOR		
Q103-106			2SC1845F	TRANSISTOR VS2SC1845F/-1T		
Q107,108			KTC3199GR	TRANSISTOR VSKTC3199GR-1T		
Q109			KTA1266GR	TRANSISTOT VSKTA1266GR-1T		
Q110,111			KRC104M	TRANSISTOR VSKRC104M// -1T		
Q121,122			KTC3199GR	TRANSISTOR VSKTC3199GR-1T		
Q124			2SA1015GR	TRANSISTOR VS2SA1015GR-1T		
Q126			KRC104M	TRANSISTOR VSKRC104M// -1T		
Q128			KTC3203Y	TRANSISTOR VSKTC3203Y/-1T		
Q302			KTC3194Y	TRANSISTOR VSKTC3194Y/-1T		
Q360			KTA1266GR	TRANSISTOT VSKTA1266GR-1T		
Q603-606			KTC3199GR	TRANSISTOR VSKTC3199GR-1T		
Q700			KRC102M	TRANSISTOR VSKRC102M// -1T		

L : Scandinavia K : USA P : Canada R : Mexico C : China I : Malaysia  
 Y : PX(Far East,Hawaii) T : England E : Europe G : Germany V : China(Shanghai)  
 Y : AAFES(Europe) X : Australia Q : Russia H : Korea M : Other Areas Δ indicates safety critical components .

PARTS LIST

RXD-V555/V757

\* New Parts  
Parts without **Parts No.** are not supplied.  
Les articles non mentionnés dans le **Parts No.** ne sont pas fournis.  
Teile ohne **Parts No.** werden nicht geliefert.

15

Ref. No	Add-ress	New Parts	Parts No.	Description	Desti-nation	Re-marks
Q703			KTA1273Y	TRANSISTOR	VSKTA1273Y/-1T	
Q704,705			KTA1271Y	TRANSISTOR	VSKTA1271Y/-1T	
Q706-708			KTC3199GR	TRANSISTOR	VSKTC3199GR-1T	
Q709			KRC102M	TRANSISTOT	VSKRC102M//1-1T	
Q712			KRC102M	TRANSISTOT	VSKRC102M//1-1T	
△ Q801			AN78L05	IC(VOLTAGE REGULATOR/ +5V)/-1T		
△ Q802			KTC3199GR	TRANSISTOR	VSKTC3199GR-1T	
Q803			KTA1274Y	TRANSISTOR	VSKTA1274Y/-1T	
Q850			KTC2026	TRANSISTOR	VSKTC2026//1-1	
Q851			KIA7810AP	IC	VHikia7810AP1	
Q852			KIA7805AP	MOS-IC	VHikia7805AP1	
Q862,863			KTC3199GR	TRANSISTOR	VSKTC3199GR-1T	
Q864			KRC102M	TRANSISTOT	VSKRC102M//1-1T	
Q865			KTC3199GR	TRANSISTOR	VSKTC3199GR-1T	
Q901-904			KTC3199GR	TRANSISTOR	VSKTC3199GR-1T	
Q905			KRC107M	TRANSISTOR	VSKRC107M//1-1T	
Q907			KTC3203Y	TRANSISTOR	VSKTC3203Y/-1T	
QK1			KTC3203Y	TRANSISTOR	VSKTC3203Y/-1T	
QM1		*	KTC3265Y	TRANSISTOR	VSKTC3265Y/-1+	
QM3			KRC104S	TRANSISTOR		
QM5			KTA1046Y	TRANSISTOR		
QM6			KTC3203Y	TRANSISTOR		
ZDK1			MTZJ5R6B	ZENER DIODE		
ZD1		*	EZ02W4R3Z	ZENER DIODE	VHEZ02W4R3Z-1+	
ZD61		*	EZ02W3R9Z	ZENER DIODE	VHEZ02W3R9Z-1+	
ZD351			DZ5R1BSB	ZENER DIODE	VHEDZ5R1BSB-1T	
ZD561			DZ6R2BSC	ZENER DIODE	VHEDZ6R2BSC-1T	
ZD801			DZ30BSC	ZENER DIODE	VHEDZ30BSC-1T	
ZD802			DZ6R2BSA	ZENER DIODE	VHEDZ6R2BSA-1T	
ZD803			DZ4R3BSC	ZENER DIODE	VHEDZ4R3BSC-1T	
ZD804			DZ110BSB	ZENER DIODE	VHEDZ110BSB-1T	
ZD851			DZ2R4BSB	ZENER DIODE	VHEDZ2R4BSB-1T	
ZD901,902			DZ120BSB	ZENER DIODE	VHEDZ120BSB-1T	
ZD951			DZ130BSB	ZENER DIODE	VHEDZ130BSB-1T	
RX701			W02-2689-08	OPTICAL MODULE	VHLN63H380A-1	
<b>MECHANISM</b>						
1	2A		D13-1869-08	GEAR	NGERH0011AWZZ	
2	2A		D13-1870-08	GEAR	NGERH0012AWZZ	
5	2A		G13-2515-08	GUSHION	MCUSN1524A	
6	2A		T25-0115-08	OPTICAL PICKUP	HPC1LXASY	
24	1A		D02-0145-08	TURNTABLE	PT0331105	
32	2B		D16-0776-08	BELT	BE231616	
34	3B		J39-1037-08	SPACER	EVA0330702	
35	1A		T99-0656-08	MAGNET	MAG0104302	
38	2A		J39-1036-08	SPACER	NM0305401	
39	2A,3A		D14-0818-08	ROLLER	PT0303002	
40	3B		D10-5013-08	LEVER(STOP)	PT0304303	
41	2A		D32-0370-08	STOPPER	PT0304304	
42	3B		D10-5012-08	LEVER(LOCK)	PT0304305	
43	1A		J19-6229-08	STABILIZER	PT0304306	
45	2A		D19-0329-08	PIN(LOCK)	PT0304308	
46	2B		F09-0162-08	CAP	PT0304309	
47	2A		D13-2565-08	GEAR	PT0305413	
48	2A		D13-2559-08	GEAR	PT0309506	

L : Scandinavia    K : USA    P : Canada    R : Mexico    C : China    I : Malaysia  
Y : PX(Far East,Hawaii)    T : England    E : Europe    G : Germany    V : China(Shanghai)  
Y : AAFES(Europe)    X : Australia    Q : Russia    H : Korea    M : Other Areas    △ indicates safety critical components .

\* New Parts  
Parts without **Parts No.** are not supplied.  
Les articles non mentionnés dans le **Parts No.** ne sont pas fournis.  
Teile ohne **Parts No.** werden nicht geliefert.

16

Ref. No	Add-ress	New Parts	Parts No.	Description	Desti-nation	Re-marks
49	2A		D13-2561-08	GEAR	PT0309507	
50	2A		D13-2563-08	GEAR	PT0309508	
51	2A		D13-2560-08	GEAR	PT0309509	
52	2B		D15-0445-08	PULLEY(GEAR)	PT0309510	
53	2A		D13-2562-08	GEAR	PT0309511	
54	2B		D10-5014-08	LEVER(CLAMP)	PT0311101	
55	2A		D10-5015-08	LEVER(DISC )	PT0311102	
56	2A		D13-2564-08	GEAR(CAM)	PT0312005	
57	1A		J19-6227-08	HOLDER	PT0320201	
60	3A		J99-0834-08	TRAY(SLIDE)	PT0331003	
62	2A		G01-4278-08	SPRING(STOP)	SP0304303	
63	3B		G01-4277-08	SPRING(LOCK)	SP0304305	
64	2A		G01-4279-08	SPRING	SP0304306	
66	1A		D19-0330-08	METAL PLATE	MT0304302	
AL	2A		N09-5335-08	MACHINE SCREW	LX-BZ2222AXZZ	
AM	3A		N09-5332-08	MACHINE SCREW	SC0308MBZI	
AR			N19-1526-08	FLAT WASHER	LX-WZ1070AFZZ	
DM	2A	*	T42-1120-08	MOTOR ASSY	MMTR1651B	
FM	2A		T42-1114-08	MOTOR ASSY	MMTR1854A	
M3	2B		T41-0140-08	MOTOR ASS'Y	TWMEN7E6Y	

L : Scandinavia    K : USA    P : Canada    R : Mexico    C : China    I : Malaysia  
Y : PX(Far East,Hawaii)    T : England    E : Europe    G : Germany    V : China(Shanghai)  
Y : AAFES(Europe)    X : Australia    Q : Russia    H : Korea    M : Other Areas    △ indicates safety critical components .

**HOW TO READ THE PARTS LIST**  
**ABBREVIATION OF MODEL AND MASS PRODUCTION'S DESTINATIONS**

MODEL	ABB.	Australia	Canada	China	England	Europe	Germany	Korea	Malaysia
RXD-V555	5	-	-	-	-	-	-	-	I
RXD-V555-H	6	-	-	-	-	-	-	-	-
RXD-V757	7	-	-	-	-	-	-	-	I
MODEL	ABB.	Mexico	PX/AAFES	Russia	Scandinavia	Shanghai	USA	Other area	
RXD-V555	5	-	-	-	-	-	-	M	-
RXD-V555-H	6	-	-	-	-	-	-	M	-
RXD-V757	7	-	-	-	-	-	-	M	-

# RXD-V555/V757

## SPECIFICATIONS

### RXD-V757

#### Main Unit

##### [Amplifier section]

Rated power output  
1 kHz, 1% T.H.D., 6 Ω.....(RMS) 122 W + 122 W  
Effective output power during STEREO operation  
1 kHz, 10% T.H.D., 6 Ω.....(RMS) 150 W + 150 W  
Signal to noise ratio  
VIDEO/AUX INPUT.....88 dB (IHF' 66)  
Input sensitivity / impedance  
VIDEO/AUX INPUT.....600 mV / 47 kΩ

##### [Tuner section]

FM tuner section  
Tuning frequency range.....87.5 MHz ~ 108 MHz

#### MW (AM) Tuner section

Tuning frequency range  
9 kHz step.....531kHz ~ 1,602kHz  
10 kHz step.....530kHz ~ 1,620kHz

##### [Cassette deck section]

Track.....4-track, 2-channel stereo  
Recording system.....AC bias system  
(Frequency: 100 kHz)

#### Heads

A deck : Playback head.....1  
B deck : Playback / recording head.....1  
Erasing head.....1  
Fast winding time.....Approx. 100 seconds  
(C-60 tape)

##### [CD (VIDEO CD) player section]

Laser wave length.....770 to 795 nm  
Laser power class.....1 (IEC)  
Wow & Flutter.....Less than unmeasurable limit  
Video Output format.....NTSC/PAL  
Video Output lever.....1 Vp-p (75 Ω)

##### [General]

Power consumption.....130 W  
Dimensions.....W : 270mm (10-5/8")  
H : 330mm (13")  
D : 390mm (15-3/8")  
Weight (net).....8.6 kg (19 lb)

### RXD-V555

#### Main Unit

##### [Amplifier section]

Rated power output  
1 kHz, 1% T.H.D., 6 Ω.....(RMS) 72W +72W  
Effective output power during STEREO operation  
1 kHz, 10% T.H.D., 6 Ω.....(RMS) 100W + 100W  
Signal to noise ratio  
VIDEO/AUX INPUT.....88 dB (IHF' 66)  
Input sensitivity / impedance  
VIDEO/AUX INPUT.....600 mV / 47 kΩ

##### [Tuner section]

FM tuner section  
Tuning frequency range.....87.5 MHz ~ 108 MHz

#### MW (AM) Tuner section

Tuning frequency range  
9 kHz step.....531kHz ~ 1,602kHz  
10 kHz step.....530kHz ~ 1,620kHz

##### [Cassette deck section]

Track.....4-track, 2-channel stereo  
Recording system.....AC bias system  
(Frequency: 100 kHz)

#### Heads

A deck : Playback head.....1  
B deck : Playback / recording head.....1  
Erasing head.....1  
Fast winding time.....Approx. 100 seconds  
(C-60 tape)

##### [CD (VIDEO CD) player section]

Laser wave length.....770 to 795 nm  
Laser power class.....1 (IEC)  
Wow & Flutter.....Less than unmeasurable limit  
Video Output format.....NTSC/PAL  
Video Output lever.....1 Vp-p (75 Ω)

##### [General]

Power consumption.....100W  
Dimensions.....W : 270mm (10-5/8")  
H : 330mm (13")  
D : 390mm (15-3/8")  
Weight (net).....8.5 kg ( 18.7 lb)



KENWOOD follows a policy of continuous advancements in development. For this reason specifications may be changed without notice.

- Sufficient performance may not be exhibited at extremely cold locations (Where water freezes).

## KENWOOD CORPORATION

14-6,Dogenzaka 1-chome, Shibuya-ku, Tokyo, 150-8501 Japan

### KENWOOD SERVICE CORPORATION

P.O BOX 22745, 2201 East Dominguez St., Long Beach, CA 90801-5745, U.S.A.

### KENWOOD ELECTRONICS CANADA INC.

6070 Kestrel Road, Mississauga, Ontario, Canada L5T 1S8

### KENWOOD ELECTRONICS LATIN AMERICA S.A.

P.O.BOX 55-2791, Piso 6 plaza Chase, Cl. 47 y Aquilino de la Guardia Panama, Republic de Panama

### KENWOOD ELECTRONICS BRASIL LTDA.

Alameda Ministro Rocha Azevedo No. 456, Edificio Jaú, 10o Andar, Cerqueira César, Cep 0140-001, São Paulo-SP-Brasil

### KENWOOD ELECTRONICS U.K. LIMITED

KENWOOD House, Dwight Road, Watford, Herts., WD1 8EB., United Kingdom

### KENWOOD ELECTRONICS BELGIUM N.V.

Leuvensesteenweg 248 J, 1800 Vilvoorde, Belgium

### KENWOOD ELECTRONICS DEUTSCHLAND GMBH

Rembrücker Str. 15, 63150 Heusenstamm, Germany

### KENWOOD ELECTRONICS FRANCE S.A.

13 Boulevard Ney, 75018 Paris, France

### KENWOOD ELECTRONICS ITALIA S.p.A.

Via G. Sirtori, 7/9 20129, Milano, Italy

### KENWOOD IBÉRICA S.A.

Bolivia, 239-08020 Barcelona, Spain

### KENWOOD ELECTRONICS AUSTRALIA PTY. LTD.

(A.C.N. 001 499 074)  
16 Giffnock Avenue, North Ryde, N.S.W. 2113, Australia

### KENWOOD ELECTRONICS (HONG KONG) LTD.

Unit 3712-3724, Level 37, Tower 1, Metroplaza, 223 Hing Fong Road, Kwai Fong N.T., Hong Kong

### KENWOOD ELECTRONICS GULF FZE

P.O.Box 61318, Jebel Ali, Dubai, U.A.E.

### KENWOOD ELECTRONICS SINGAPORE PTE LTD.

No. 1 Genting Lane #02-02, KENWOOD Building, Singapore, 349544

### KENWOOD ELECTRONICS (MALAYSIA) SDN BHD.

#4.01 Level 4, Wisma Academy Lot 4A, Jalan 19/1 46300 Petaling Jaya Selangor Darul Ehsan Malaysia

### KENWOOD ELECTRONICS (THAILAND) CO., LTD.

2019 New Pechburi Road, Bangkapi, Huaykwang, Bangkok, 10320 Thailand

## Free Manuals Download Website

<http://myh66.com>

<http://usermanuals.us>

<http://www.somanuals.com>

<http://www.4manuals.cc>

<http://www.manual-lib.com>

<http://www.404manual.com>

<http://www.luxmanual.com>

<http://aubethermostatmanual.com>

Golf course search by state

<http://golfingnear.com>

Email search by domain

<http://emailbydomain.com>

Auto manuals search

<http://auto.somanuals.com>

TV manuals search

<http://tv.somanuals.com>