



Start-Up and Service Instructions

SAFETY CONSIDERATIONS

Centrifugal and screw compressor liquid chillers are designed to provide safe and reliable service when operated within design specifications. When operating this equipment, use good judgment and safety precautions to avoid damage to equipment and property or injury to personnel.

Be sure you understand and follow the procedures and safety precautions contained in the chiller instructions as well as those listed in this guide.

⚠ DANGER

Failure to follow these procedures will result in severe personal injury or death.

ONLY QUALIFIED electrical personnel familiar with the construction and operation of this equipment and the hazards involved should install, adjust, operate, or service this equipment.

READ AND UNDERSTAND this manual and other applicable manuals in their entirety before proceeding. Failure to observe this precaution could result in severe bodily injury or loss of life.

DO NOT install modification kits with power applied to the drive. Disconnect and lock out incoming power before attempting such installation or removal. Failure to observe this precaution could result in severe bodily injury or loss of life.

UNUSED WIRES in conduit must be grounded at both ends to avoid a possible shock hazard caused by induced voltages. Also, if a drive sharing a conduit is being serviced or installed, all drives using this conduit should be disabled to eliminate the possible shock hazard from cross-coupled motor leads. Failure to observe these precautions could result in bodily injury.

DO NOT VENT refrigerant relief valves within a building. Outlet from rupture disc or relief valve must be vented outdoors in accordance with the latest edition of ANSI/ASHRAE 15 (American National Standards Institute/American Society of Heating, Refrigerating, and Air-Conditioning Engineers). The accumulation of refrigerant in an enclosed space can displace oxygen and cause asphyxiation.

PROVIDE adequate ventilation in accordance with ANSI/ASHRAE 15, especially for enclosed and low overhead spaces. Inhalation of high concentrations of vapor is harmful and may cause heart irregularities, unconsciousness, or death. Misuse can be fatal. Vapor is heavier than air and reduces the amount of oxygen available for breathing. Product causes eye and skin irritation. Decomposition products are hazardous.

DO NOT USE OXYGEN to purge lines or to pressurize a chiller for any purpose. Oxygen gas reacts violently with oil, grease, and other common substances.

(Dangers continued in next column.)

⚠ DANGER

NEVER EXCEED specified test pressures. **VERIFY** the allowable test pressure by checking the instruction literature and the design pressures on the equipment nameplate.

DO NOT USE air for leak testing. Use only refrigerant or dry nitrogen.

DO NOT VALVE OFF any safety device.

BE SURE that all pressure relief devices are properly installed and functioning before operating any chiller.

THERE IS A RISK OF INJURY OR DEATH by electrocution. High voltage may be present on the motor leads even though the motor is not running. Open the power supply disconnect before touching motor leads or terminals.

⚠ WARNING

Failure to follow these procedures may result in personal injury or death.

DO NOT USE TORCH to remove any component. System contains oil and refrigerant under pressure.

To remove a component, wear protective gloves and goggles and proceed as follows:

- a. Shut off electrical power to unit.
- b. Recover refrigerant to relieve all pressure from system using both high-pressure and low-pressure ports.
- c. Traces of vapor should be displaced with nitrogen and the work area should be well ventilated. Refrigerant in contact with an open flame produces toxic gases.
- d. Cut component connection tubing with tubing cutter and remove component from unit. Use a pan to catch any oil that may come out of the lines and as a gage for how much oil to add to the system.
- e. Carefully unsweat remaining tubing stubs when necessary. Oil can ignite when exposed to torch flame.

DO NOT work on high-voltage equipment unless you are a qualified electrician.

DO NOT WORK ON electrical components, including control panels, switches, VFD, or oil heater until you are sure **ALL POWER IS OFF** and no residual voltage can leak from capacitors or solid-state components.

LOCK OPEN AND TAG electrical circuits during servicing. **IF WORK IS INTERRUPTED**, confirm that all circuits are de-energized before resuming work.

AVOID SPILLING liquid refrigerant on skin or getting it into the eyes. **USE SAFETY GOGGLES**. Wash any spills from the skin with soap and water. If liquid refrigerant enters the eyes, **IMMEDIATELY FLUSH EYES** with water and consult a physician.

(Warnings continued on next page.)

⚠ WARNING

DO NOT ATTEMPT TO REMOVE fittings, covers, etc., while chiller is under pressure or while chiller is running. Be sure pressure is at 0 psig (0 kPa) before breaking any refrigerant connection.

⚠ CAUTION

Failure to follow these procedures may result in personal injury or damage to equipment.

TO AVOID an electric shock hazard, verify that the voltage on the bus capacitors has discharged completely before servicing. Check the DC bus voltage at the power terminal block by measuring between the +DC and -DC terminals, between the +DC terminal and the chassis, and between the -DC terminal and the chassis. The voltage must be zero for all 3 measurements.

THE USER is responsible to conform with all applicable local, national, and international codes. Failure to observe this precaution could result in damage to, or destruction of, the equipment.

THIS DRIVE contains ESD (electrostatic discharge) sensitive parts and assemblies. Static control precautions are required when installing, testing, servicing or repairing this assembly. Component damage may result if ESD control procedures are not followed. For static control procedures, reference Rockwell publication Guarding Against Electrostatic Damage, or any other applicable ESD protection handbook.

DO NOT alter the setting of any jumper. Failure to observe this precaution could result in damage to, or destruction of, the equipment.

USE OF power correction capacitors on the output of the drive can result in erratic operation of the motor, nuisance tripping, and/or permanent damage to the drive. Remove power correction capacitors before proceeding. Failure to observe this precaution could result in damage to, or destruction of, the equipment.

MOST CODES require that upstream branch circuit protection be provided to protect input power wiring. If fuses are chosen as the protection method, refer to the PowerFlex 750 user manual. Failure to observe this precaution could result in damage to, or destruction of, the equipment.

DO NOT route signal and control wiring with power wiring in the same conduit. This can cause interference with drive operation. Failure to observe this precaution could result in damage to, or destruction of, the equipment.

DISTRIBUTION SYSTEM short circuit capacity shall not exceed the rating of the drive. Failure to observe this precaution could result in damage to, or destruction of, the equipment.

DO NOT STEP on refrigerant lines. Broken lines can whip about and release refrigerant, causing personal injury.

DO NOT climb over a chiller. Use platform, catwalk, or staging. Follow safe practices when using ladders.

USE MECHANICAL EQUIPMENT (crane, hoist, etc.) to lift or move inspection covers or other heavy components. Even if components are light, use mechanical equipment when there is a risk of slipping or losing your balance.

BE AWARE that certain automatic start arrangements CAN ENGAGE THE VFD, TOWER FAN, OR PUMPS. Open the disconnect ahead of the VFD, tower fans, or pumps.

(Cautions continued in next column.)

⚠ CAUTION

USE only repair or replacement parts that meet the code requirements of the original equipment.

PERIODICALLY INSPECT all valves, fittings, and piping for corrosion, rust, leaks, or damage.

DO NOT re-use compressor oil or any oil that has been exposed to the atmosphere. Dispose of oil per local codes and regulations.

DO NOT leave refrigerant system open to air any longer than the actual time required to service the equipment. Seal circuits being serviced and charge with dry nitrogen to prevent oil contamination when timely repairs cannot be completed.

CONTENTS

	Page
SAFETY CONSIDERATIONS	1
INTRODUCTION	2
ABBREVIATIONS AND EXPLANATIONS	3
Required Publications	3
Getting Assistance from Rockwell Automation	3
IDENTIFYING DRIVE COMPONENTS	3
Opening the VFD Access Door	3
Drive Assembly Catalog Number	3
Components and Physical Data	4
START-UP	7
Alternate Wire Lugs	7
Verify Installation	7
Configure the VFD	8
Commissioning the Unit	9
Check Internal Jumpers	9
SERVICE	10
Troubleshooting the Drive	10
• CHILLER ALERT CODES	
• CHILLER ALARM CODES	
• TEST EQUIPMENT NEEDED TO TROUBLESHOOT	
• VERIFYING THAT DC BUS CAPACITORS ARE DISCHARGED	
• HIGH TEMPERATURE ALARMS	
• MAIN CONTROL BOARD (MCB) COMPONENTS	
Checking Power Modules and Motor Input with Input Power Off	14
Servicing the Drive	15
• REMOVING THE DRIVE	
• RIGGING THE ENCLOSURE	
• REPLACING THE GATEWAY	
• CHILL PLATE FAN AND INTERNAL FAN REPLACEMENT	
Part Identification and Location	18
APPENDIX A — WIRING SCHEMATICS	21

INTRODUCTION

The Carrier VFD option Start-Up and Service Manual is intended for trained and qualified service personnel and is to be used during start-up, operation, and maintenance of Rockwell/Allen-Bradley PF755L drive.

ABBREVIATIONS AND EXPLANATIONS

Frequently used abbreviations in this manual include:

CCM	— Chiller Control Module
DC	— Direct Current
DPI	— Drive Peripheral Interface
ENET	— Ethernet
HMI	— Human Machine Interface
ICVC	— International Chiller Visual Controller
IGBT	— Insulated Gate Bipolar Transistor
I/O	— Inputs/Outputs
IP	— Internet Protocol
MCB	— Main Control Board
MOV	— Metal Oxide Varistor
PE	— Protective Earthing Conductor
PIC	— Product Integrated Control
PWM	— Pulse Width Modulation
SIO	— Sensor Input/Output
STS	— Status
VFD	— Variable Frequency Drive

Required Publications

The Carrier VFD option Start-Up and Service Manual must be used with the following manuals:

- Latest version of the PowerFlex 755 AC Drives manuals
- Latest revision of the Start-Up, Operation, and Maintenance Instructions for the 19XRV or 23XRV with PIC III Controls

Getting Assistance from Rockwell Automation

Contact the local Rockwell Automation sales office with any questions or problems relating to the products described in this manual. For technical support on drives, call the HVAC Hotline at 1-888-926-6786, Option 1.

Before calling, have the following information available from the Allen-Bradley data nameplate located inside the enclosure on the right wall. See Fig. 1.

- Allen-Bradley ID or CAT. NO.
- Carrier VFD Code (Carrier Part Number)
- Allen-Bradley serial number

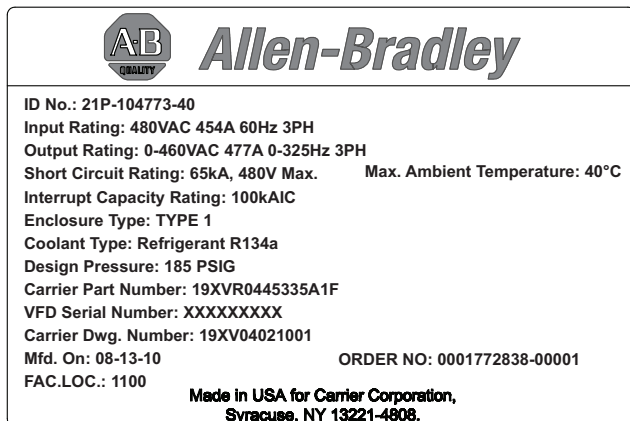

Fig. 1 — Allen Bradley Data Nameplate

IDENTIFYING DRIVE COMPONENTS

Chiller control schematics and VFD schematics are included in Appendix A.

⚠ WARNING

DC bus capacitors retain hazardous voltages after input power has been disconnected. After disconnecting input power, wait five (5) minutes for the DC bus capacitors to discharge and then check the voltage with a voltmeter rated for the DC bus voltage to ensure the DC bus capacitors are discharged before touching any internal components. Failure to observe this precaution could result in severe bodily injury or loss of life.

An isolated multimeter will be needed to measure DC bus voltage and to make resistance checks. The drive's DC bus capacitors retain hazardous voltages after input power has been disconnected.

Opening the VFD Access Door

⚠ WARNING

Before removing the drive enclosure, open access door and verify that the DC bus voltage has dropped to zero by checking the terminals behind the access door. Failure to observe this precaution could result in severe bodily injury or loss of life.

1. Using recommended screwdriver (6.4 mm [0.25 in.] flat or T20 star), open access door. See Fig. 2.
2. Check to be sure that the voltage between DC+ and DC- and from each DC terminal to the chassis is zero before proceeding. See Fig. 3.

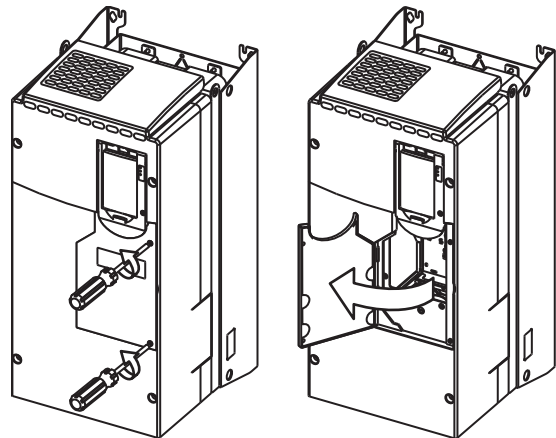

Fig. 2 — Opening Access Door

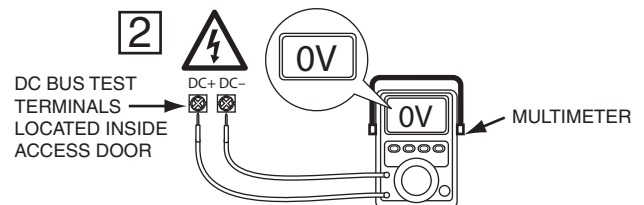
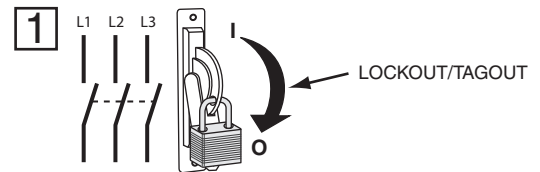

Fig. 3 — Check DC Bus Terminals

Drive Assembly Catalog Number

See Fig. 4 and 5 for examples of the Rockwell Automation Drive Assembly Catalog Number.

Components and Physical Data

The 19XRV chillers use the Allen-Bradley PF755 Frame 6 drive for the 230-amp rated application (Carrier Part No. 19XVR0230...). See Fig. 6.

The Allen-Bradley PF755 Frame 7 drive is used for the 335-amp and 445-amp rated application (Carrier Part No. 19XVR0335... and 19XVR0445...). See Fig. 7.

See Fig. 8 for the dimensions of Frames 6 and 7 for 19XRV chillers.

The 23XRV chiller uses the Frame 7 drive for 335-amp and 455-amp rated applications (Carrier Part No. 23XVR0335... and 23XVR0445...). Frame 6 is not used.

See Fig. 9 for the dimensions of Frame 7 for 23XRV chillers.

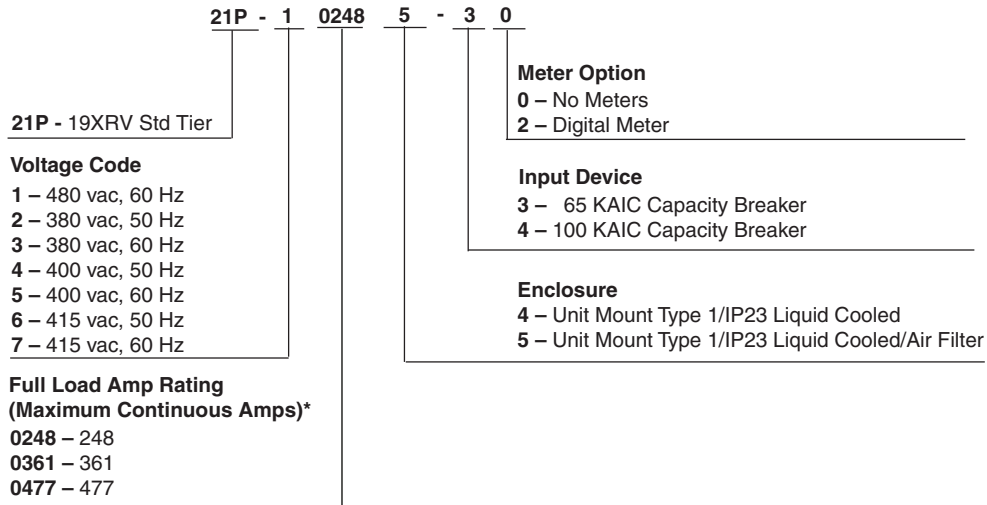

* For Carrier applications, maximum continuous amp ratings are 230, 335, and 445.

Fig. 4 — Rockwell Automation Drive Assembly Catalog Number Nomenclature: 19XRV Units

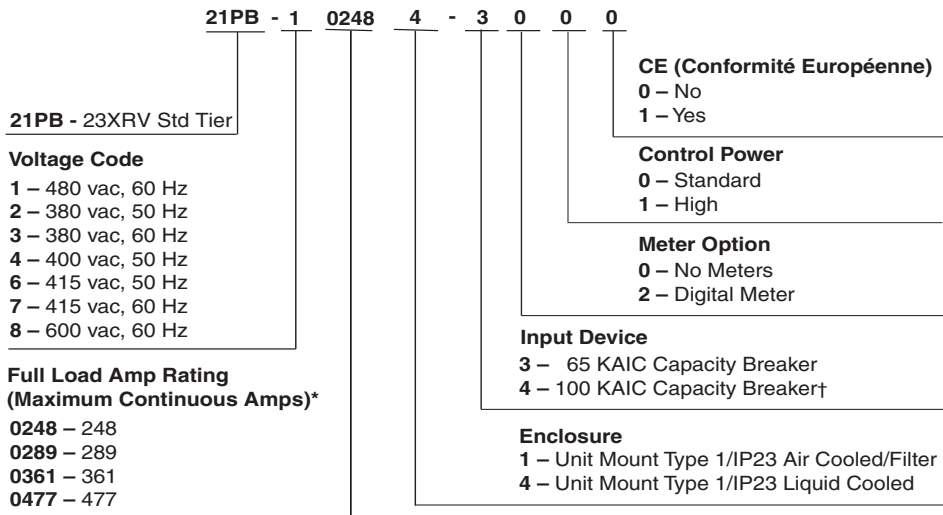

* For Carrier applications, maximum continuous amp ratings are 230, 269, 335, and 445.

† For 600 v applications, CB1 = 65 KAIC and CB2 = 42 KAIC rating (575 v).

Fig. 5 — Rockwell Automation Drive Assembly Catalog Number Nomenclature: 23XRV Units

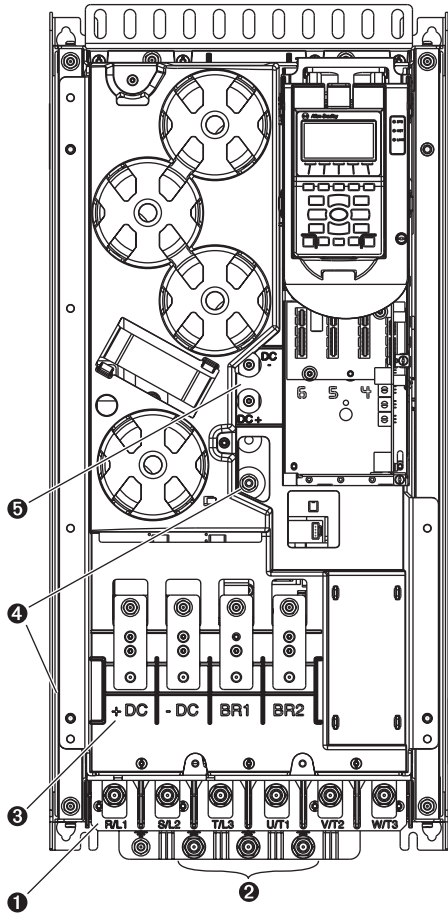

LEGEND

NO.	NAME	DESCRIPTION
1	Power Terminals	R/L1, S/L2, T/L3, U/T1, V/T2, W/T3
2	PE Grounding Studs	Terminating point to chassis ground for incoming motor shield
3	DC Bus and Brake Terminals	+DC, -DC, BR1, BR2
4	PE-A and PE-B	MOV and CMC Jumper Wires
5	DC+ and DC-	Bus Voltage Test Points

Fig. 6 — Frame 6 Drive Components

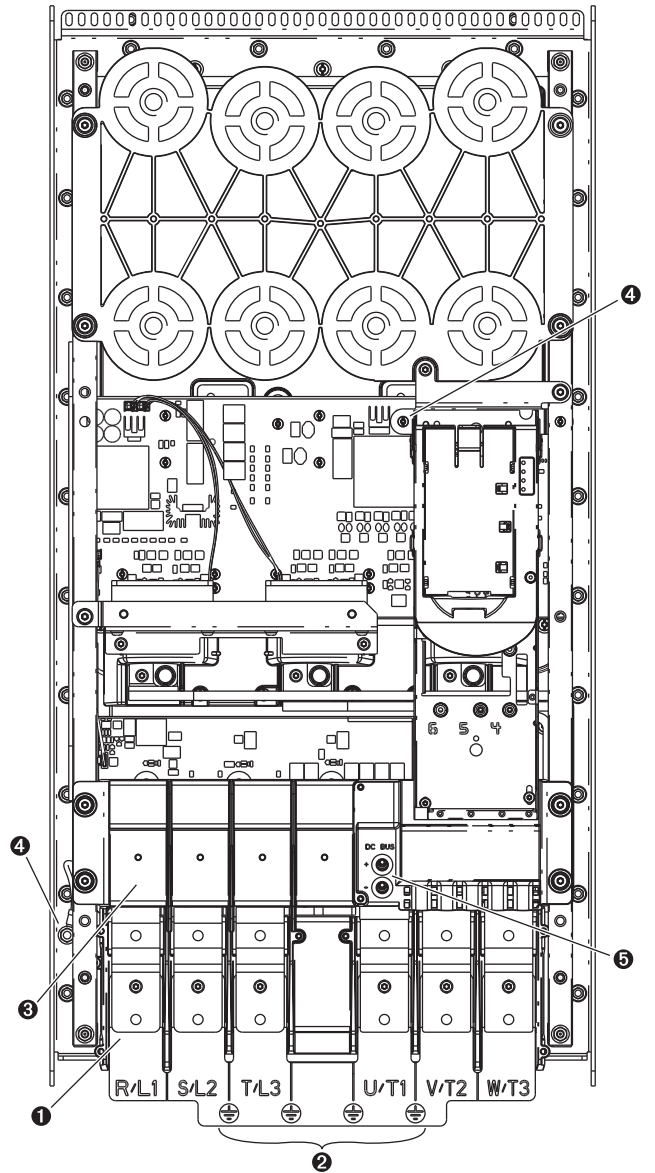

LEGEND

NO.	NAME	DESCRIPTION
1	Power Terminals	R/L1, S/L2, T/L3, U/T1, V/T2, W/T3
2	PE Grounding Studs	Terminating point to chassis ground for incoming motor shield
3	DC Bus and Brake Terminals	+DC, -DC, BR1, BR2
4	PE-A and PE-B	MOV and CMC Jumper Wires
5	DC+ and DC-	Bus Voltage Test Points

Fig. 7 — Frame 7 Drive Components

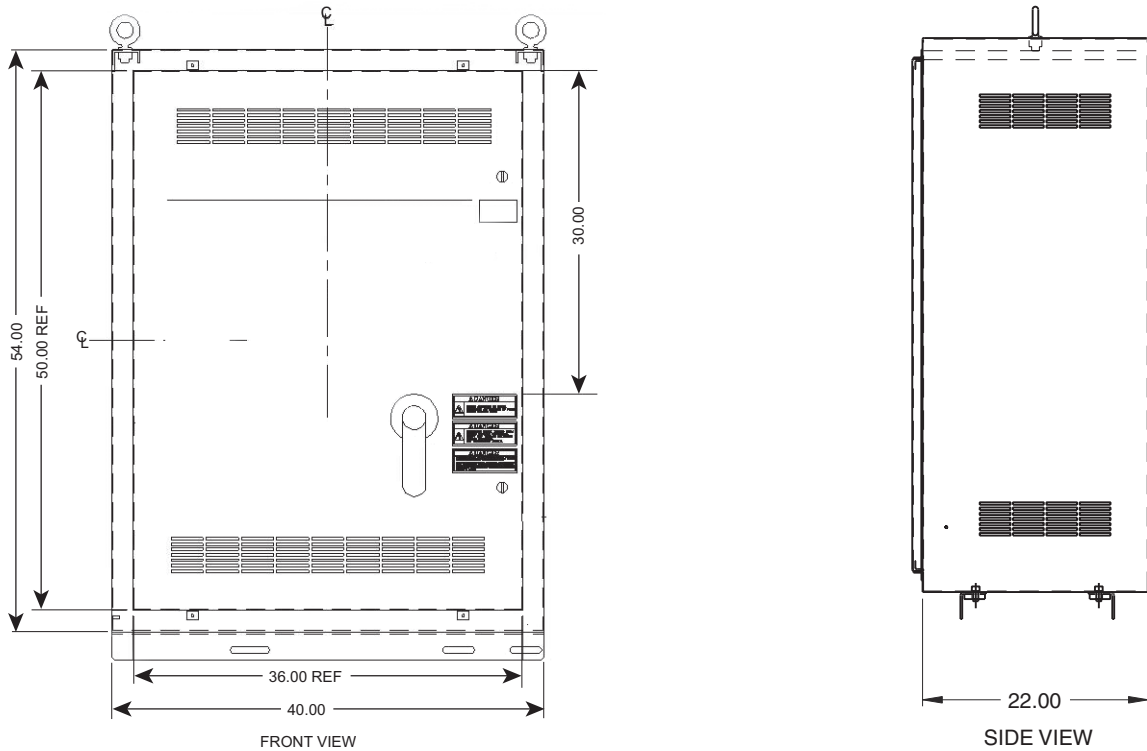

NOTE: Dimensions shown in inches.

Fig. 8 — 19XRV Enclosure Dimensions — Frames 6 and 7

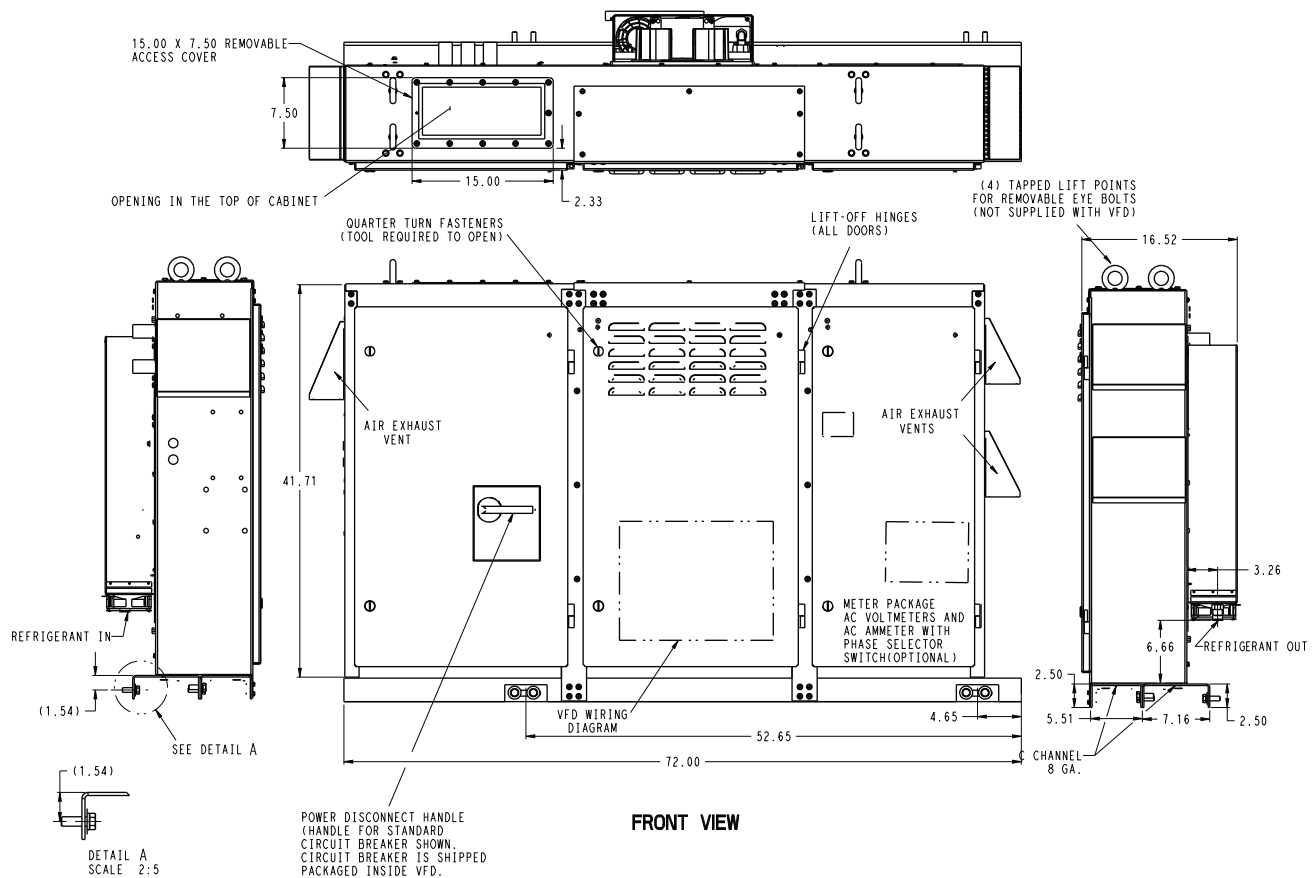

NOTE: Dimensions shown in inches.

Fig. 9 — 23XRV Enclosure Dimensions — Frame 7

START-UP

DANGER

Internal components and circuit boards of the drive are live when the drive is connected to incoming power. Coming into contact with this voltage is extremely dangerous and will result in severe personal injury or death.

The motor terminals U, V, W and the DC-link/brake resistor terminals B+/R+, R- are live when the drive is connected to incoming power, even if the motor is not running.

Do not make any connections when the drive is connected to the incoming power.

After having disconnected the drive, wait until the indicators on the keypad go out (if no keypad is attached see the indicator through the keypad base). Wait 5 more minutes before doing any work on drive connections. Do not even open the cover before this time has expired.

Before connecting the drive to the incoming power, make sure that the switchgear enclosure door is closed.

WARNING

The control I/O-terminals are isolated from the mains potential. However, the relay outputs and other I/O terminals may have a dangerous control voltage present even when the drive is disconnected from incoming power. Coming into contact with this voltage could result in severe personal injury.

CAUTION

If other than refrigerant cooling is used, before connecting the drive to the incoming power, make sure that the coolant is circulating and has no leaks.

CAUTION

When working with the Drive Explorer, *never* use the Rotate function as the motor will immediately start and severe compressor damage could result.

Alternate Wire Lugs

If the incoming power wire size does not fit the standard lug, alternate lugs may be used. See Table 1. Note that lugs rated for a higher current than the circuit breaker may be used.

Verify Installation

Record the following job information:

1. Job Name
2. Job Number
3. City
4. State
5. Zip Code

Record the following nameplate information:

1. From the Allen-Bradley nameplate (Fig. 1) located inside the VFD enclosure:
 - a. Allen-Bradley ID or CAT NO.
 - b. Allen-Bradley Serial Number
 - c. Carrier Part Number
2. From the machine nameplate (Fig. 10) located inside the VFD enclosure:
 - a. Chiller Serial Number
 - b. Chiller Model
 - c. Motor rated load amps
 - d. Motor nameplate rpm
 - e. Motor nameplate kW
 - f. Motor nameplate voltage
 - g. Inverter PWM (pulse width modulation) frequency
 - h. Voltage
3. From the drive module label (Fig. 11) located on the drive module:
 - a. Model or Cat. Number
 - b. Serial Number
4. From the HMI control panel screen:
 - a. Carrier Part Number and Revision
 - b. Software Number

Table 1 — Wire Lugs

VOLTAGE	CARRIER VFD MAX INPUT AMPS	STANDARD ABB LUG	STANDARD LUG CABLE RANGE	ALTERNATE ABB LUG	ALTERNATE LUG CABLE RANGE
480	230	KT5300	(1) 250 - 500 MCM	KT5400	(2) 3/0 - 250 MCM
	335	K6TJ	(3) 2/0 - 400 MCM	K6TH	(2) 250 - 500 MCM
	445	K6TJ	(3) 2/0 - 400 MCM	K6TH	(2) 250 - 500 MCM
380/400/415	230	KT5400	(2) 3/0 - 250 MCM	KT5300	(1) 250 - 500 MCM
	335	K6TJ	(3) 2/0 - 400 MCM	K6TH	(2) 250 - 500 MCM
	445	K6TJ	(3) 2/0 - 400 MCM	K6TH	(2) 250 - 500 MCM
600	269	KT5300	(1) 250 - 500 MCM	KT5400	(2) 3/0 - 250 MCM

 Carrier A United Technologies Company	
MODEL NUMBER	
SERIAL NUMBER	
MACHINE NAMEPLATE SUPPLY DATA	
VOLTS/PHASE/HERTZ	
LOCKED ROTOR AMPS	
OVERLOAD TRIP AMPS	
MAX FUSE/CIRCUIT BREAKER SIZE	
MIN SUPPLY CIRCUIT AMPACITY	
MACHINE ELECTRICAL DATA	
MOTOR NAMEPLATE VOLTAGE	
COMPRESSOR 100% SPEED	
RATED LINE VOLTAGE	
RATED LINE AMPS	
RATED LINE KILOWATTS	
MOTOR RATED LOAD KW	
MOTOR RATED LOAD AMPS	
MOTOR NAMEPLATE AMPS	
MOTOR NAMEPLATE RPM	
MOTOR NAMEPLATE KW	
INVERTER PWM FREQUENCY	
SAFETY CODE CERTIFICATION THE COMPRESSOR MOTOR CONTROLLER AND OVERLOAD PROTECTION MUST BE IN ACCORDANCE WITH CARRIER SPECIFICATION 2-149.	
199V5568761 REV. 3	

Fig. 10 — Machine Nameplate



Nameplate 1: Specifications and Custom Catalog Number representing options installed at factory. See Nameplate 2 (Located behind HIM) for equivalent base catalog number and separate options		
Cat No: 20GYA N D 477 ANONNNNNQBQ UL Open Type / IP00 Series: A		
	400V Class	480V Class
Power ND (HD)	270kW (200kW)	400 HP (300 HP)
Input: 3 Phase 47-63Hz		
AC Voltage Range	342-440	432-528
Amps ND (HD)	467.3 (359.5)	447.8 (338.9)
Output: 3 Phase 0-400 Hz		
AC Voltage Range	0-400	0-480
Base Frequency (default)	50 Hz	60 Hz
Continuous Amps ND (HD)	477 (367)	477 (361)
60 Sec Ovid Amps ND (HD)	524.7 (550.5)	524.7 (541.5)
3 Sec Ovid Amps ND (HD)	715.5 (684)	715.5 (649.8)
COOLANT	Treated Water/R134A	
RATED PRESSURE	185 PSIG	
Mfd. on 2010/08/09	Original Firmware: 1.015	
 PRODUCT OF USA FAC 1100 Serial Number: 13865138		
		

Fig. 11 — Drive Module Label

Configure the VFD

All configurations required by the VFD are supplied by the HMI through the VFD Gateway. The 19XRV, 23XRV Std Tier VFD can operate with PIC III and PIC 6. Any configuration changes necessary and possible are made on the HMI screens. A complete

set of configurations is transmitted to the VFD each time the controls are powered up.

Table 2 lists parameters displayed on the 19XRV, 23XRV PIC3/VFD_CONF screen. Table 3 shows parameters in the Unit Mounted VFD Configuration menu for PIC6. Parameters in *italics* are to be entered or confirmed at start-up. Parameters in **bold** are to be changed only after consulting with Carrier service engineering.

Table 2 — VFD Configurations (PIC3/VFD_CONF)

PARAMETER	DEFAULT VALUE
<i>MOTOR NAMEPLATE VOLTAGE</i>	460
COMPRESSOR 100% SPEED	
<i>LINE FREQ=60 HZ? (NO=50)</i>	YES
<i>RATED LINE VOLTAGE*</i>	460
<i>RATED LINE AMPS* †</i>	200
<i>RATED LINE KILOWATTS*</i>	100
<i>MOTOR RATED LOAD KW</i>	100
<i>MOTOR RATED LOAD AMPS</i>	200
<i>MOTOR NAMEPLATE AMPS</i>	100
<i>MOTOR NAMEPLATE RPM</i>	3456
<i>MOTOR NAMEPLATE KW</i>	100
<i>INVERTER PWM FREQUENCY (0 = 4 KHZ, 1 = 2 KHZ)</i>	1
SKIP FREQUENCY 1 (HZ)	20.0
SKIP FREQUENCY 2 (HZ)	20.0
SKIP FREQUENCY 3 (HZ)	20.0
SKIP FREQUENCY BAND LINE (HZ)	0.0
VOLTAGE % IMBALANCE	10
LINE VOLT IMBALANCE TIME (SEC)	10
LINE CURRENT % IMBALANCE	40
LINE CURRENT IMBAL TIME (SEC)	10
MOTOR CURRENT % IMBALANCE	40
MOTOR CURRENT IMBAL TIME	10
INCREASE RAMP TIME (SEC)	30
DECREASE RAMP TIME (SEC)	30
SINGLE CYCLE DROPOUT (DSABLE/ENABLE)	DSABLE

* Parameters marked with an * are not downloadable to the VFD but are used in other calculations and algorithms in the ICVC.

NOTES:

- Parameters in *italics* are to be entered or confirmed at start-up.
- Parameters in **bold** are to be changed only after consultation with service engineering.

Table 3 — VFD Configuration (PIC6/UM VFD Configuration) CFGUMVFD - UM VFD Configuration

PARAMETER	DEFAULT VALUE
COMPRESSOR 100% SPEED	60
<i>RATED LINE VOLTAGE*</i>	460
<i>MOTOR NAMEPLATE CURRENT</i>	200
<i>MOTOR RATED LOAD CURRENT</i>	200
<i>MOTOR NAMEPLATE VOLTAGE</i>	460
<i>MOTOR NAMEPLATE RPM</i>	3000
<i>MOTOR NAMEPLATE KW</i>	1500
SKIP FREQUENCY 1	30
SKIP FREQUENCY 2	30
SKIP FREQUENCY 3	30
SKIP FREQUENCY BAND	0
INCREASE RAMP TIME	30
DECREASE RAMP TIME	30
LINE VOLTAGE IMBALANCE%	10
LINE VOLT IMBALANCE TIME	10
LINE CURRENT IMBALANCE%	40
LINE CURRENT IMBAL TIME	10
MOTOR CURRENT IMBALANCE%	40
MOTOR CURRENT IMBAL TIME	10
SINGLE CYCLE DROPOUT	DISABLE
<i>PWM SWITCH FREQUENCY (0=2 KHZ, 1=4 KHZ)</i>	0

NOTES:

- Parameters in *italics* are to be entered or confirmed at start-up.
- Parameters in **bold** are to be changed only after consultation with service engineering.

Commissioning the Unit

The commission procedure is as follows:

1. If the chiller has been stored outdoors, allow at least 24 hours room temperature stabilization prior to commissioning. Ensure any condensation that occurs as a result of the ambient temperature is allowed to evaporate.
2. Enter parameters in the VFD_CONF screen.
3. Install surge suppression devices if required.
4. Review the power wiring and grounding to ensure that it has been properly connected.
5. Visually examine the inside of the drive enclosure to:
 - a. Look for signs of corrosion or moisture residue.
 - b. Remove any dirt or debris.
 - c. Make sure all vents are clear.
6. Apply power to the drive and take thermal measurements of the capacitor bank and power connections. Do this again before start-up.
7. Measure and record the incoming line voltage. Line-to-line voltages should be balanced within 3% as calculated by Rockwell's procedure below:

Measure voltages phase-to-phase and phase-to-ground.

V_{max} = Maximum measured phase-to-phase voltage
(A to B, B to C, C to A)

V_{min} = Minimum measured phase-to-phase voltage

Imbalance Calculation Formula

$$V_{avg} = \frac{(V_{AB} + V_{BC} + V_{CA})}{3}$$

$$\text{Imbalance \%} = \frac{(V_{max} - V_{min}) \times 100}{V_{avg}}$$

8. Take a final thermal measurement of the capacitor bank and power after finalizing the installation to ensure all connections are good.
9. If a ground fault occurs, then do the following:
 - a. Check for a ground in the motor or motor wiring.
 - b. Check for damage to wiring insulation and that wiring is dry.
 - c. Verify the motor wiring is separated from ground and there is no connection between phases.
 - d. Check for failed IGBTs.
10. If an overcurrent fault occurs, then do the following:
 - a. Check for excessive load and verify load limit settings on the HMI.
 - b. Check motor and wiring insulation.
 - c. Check parameter settings on VFD_CONF screen in the HMI (PIC3) or UM VFD Configuration for PIC 6.

Check Internal Jumpers

On the Main VFD Control board there are 2 jumpers labeled J1 HARDWARE ENABLE and J2 SAFETY ENABLE. J1 should be removed and J2 should be in place. See Fig. 12.

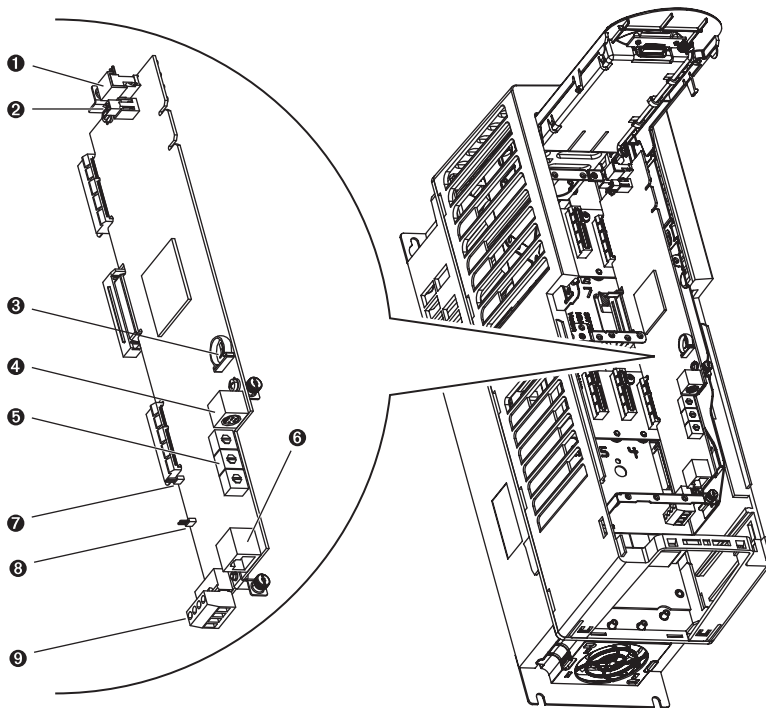

LEGEND

NO.	NAME	DESCRIPTION
1	HIM (Human Interface Module) Connector	DPI Port 1 (HIM Cradle) connection.
2	Fan Connector	Power supply for internal cooling fan (Frames 2 and 3).
3	Battery Receptacle	User-installed CR1220 lithium coin cell battery provides power to the real-time clock (Optional, not supplied).
4	DPI Port 2	Cable connection for handheld and remote HIM options.
5	Embedded Ethernet/IP Address Selectors	Rotary switches for setting lowest octet of Ethernet address (forces address to 192.168.1.xxx).
6	Embedded Ethernet/IP Connector	Network cable connection.
7	Jumper J2 SAFETY ENABLE	Safety enable jumper. Removed when safety option is installed. For additional information, refer to the Check Internal Jumpers section on page 9.
8	Jumper J1 HARDWARE ENABLE	Hardware enable jumper. Removed when a hardware enable configuration is utilized. For additional information, refer to the Check Internal Jumpers section on page 9.
9	TB1	I/O terminal block.

TB1 I/O TERMINAL DESIGNATIONS

FIXED I/O	TERMINAL	NAME	DESCRIPTION
	Di 0ac	Digital Input 120V AC	Connections for AC power supply.
	Di C	Digital Input Common	Digital input common
	Di 0dc	Digital Input 24V DC	Connections for DC power supply.
	+24V	+24 Volt Power	Connections for drive supplied 24V power.
	24VC	24 Volt Common	

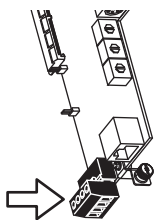

IMPORTANT: Wiring to pluggable terminal block connectors should be supported by wire ties or other means to help prevent unintentional disconnection.

Fig. 12 — PF755 Main Control Board

Two jumper wires connect a particular terminal to chassis ground. The MOV and AC EMI jumper should be connected to the PE-A terminal. The COMMON MODE CAPACITORS to GROUND jumper should be connected to a standoff rather than the PE-B terminal.

Use the recommended tools as follows when connecting jumper wires in Frame 6 and in Frame 7:

- Recommended torque (screws and nuts) = 1.36 N·m (120.0 lb-in.)
- Recommended hex socket = 7 mm
- Recommended screwdriver = T20 star type

See Fig. 13 and Fig. 14 for the correct positions of the jumpers.

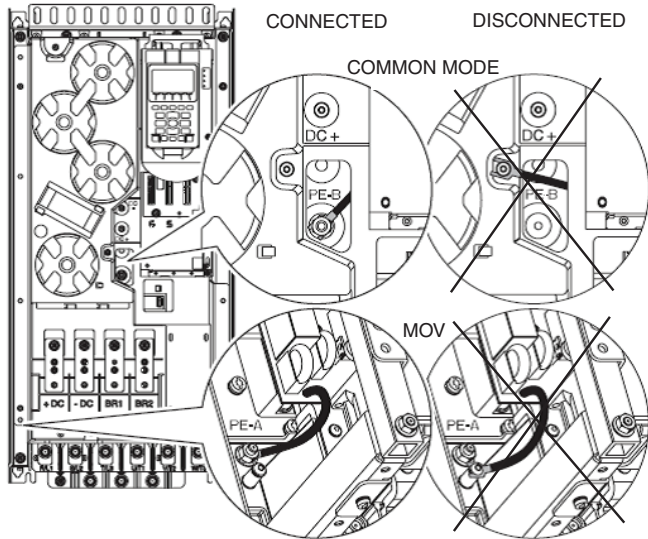

Fig. 13 — Jumper Wire Locations — Frame 6

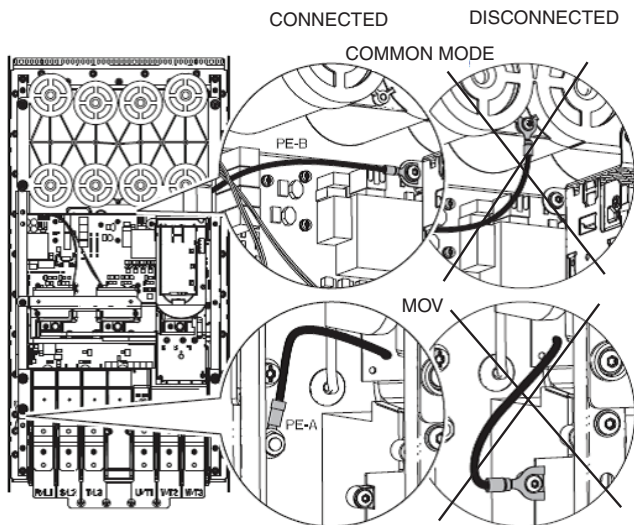

Fig. 14 — Jumper Wire Locations — Frame 7

SERVICE

⚠ WARNING

DC bus capacitors retain hazardous voltages after input power has been disconnected. After disconnecting input power, wait five (5) minutes for the DC bus capacitors to discharge and then check the voltage with a voltmeter to ensure the DC bus capacitors are discharged before touching any internal components. Failure to observe this precaution could result in severe bodily injury or loss of life.

Troubleshooting the Drive

The drive can display 2 kinds of error codes on the HMI called Alert and Alarm codes. These codes signal a problem detected during self-tuning or drive operation. Note the following differences between Carrier and Allen-Bradley terminology:

- A warning message on the HMI is an ALERT.
- The same warning viewed with Rockwell Drive Explorer is a VFD ALARM.
- A failure resulting in a shutdown is seen as an ALARM on the HMI and as a VFD FAULT when viewed with Drive Explorer.

CONDITION CODES

CHILLER ALERT = VFD ALARM

CHILLER ALARM = VFD FAULT

See Tables 4-5 and Fig. 15.

CHILLER ALERT CODES

An alert condition is indicated by a message on the HMI screen. The drive will continue to operate during the alert condition. Investigate the cause of the alert to ensure it does not lead to a fault condition. The alert code will automatically be cleared from the HMI when the condition causing the alert no longer exists. See the 19XRV or 23XRV Start-Up, Operation and Maintenance Instructions for ICVC alert codes or appropriate Controls Operation and Troubleshooting manual for PIC6 controls.

CHILLER ALARM CODES

An alarm condition is also indicated by a message on the HMI screen. If an alarm occurs, the drive coasts to stop. The STS (status) light on the drive will turn from green to red or yellow (see Table 4). The detected fault message is maintained on the display until it is cleared by pressing the RESET softkey. See the 19XRV or 23XRV Start-Up, Operation and Maintenance Instructions for ICVC alarm codes or appropriate Controls Operation and Troubleshooting manual for PIC6 controls.

TEST EQUIPMENT NEEDED TO TROUBLESHOOT

An isolated multimeter adequately rated for the DC bus voltage will be needed to measure DC bus voltage and to make resistance checks. Note that dedicated troubleshooting test points are not provided.

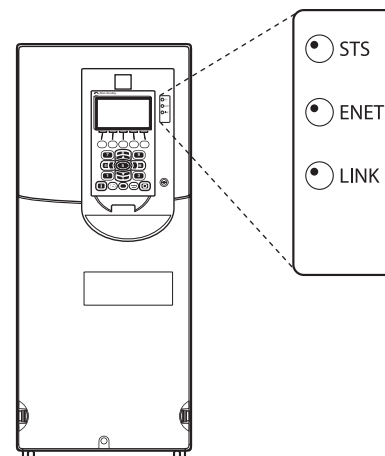

Fig. 15 — Drive Status Indicator

Table 4 — Drive Status Indicator Descriptions

NAME	COLOR	STATE	DESCRIPTION
STS (Status)	Green	Flashing	Drive ready but not running, and no faults are present.
		Steady	Drive running, no faults are present.
	Yellow	Flashing	Drive is not running. A type 2 (non-configurable) alarm condition exists, and the drive cannot be started.
		Steady	Drive is not running, a type 1 alarm condition exists. The drive can be started.
	Red	Flashing	A major fault has occurred. Drive cannot be started until fault condition is cleared.
		Steady	A non-resettable fault has occurred.
	Red/Yellow	Flashing Alternately	A minor fault has occurred. When running, the drive continues to run. System is brought to a stop under system control. Fault must be cleared to continue. Use parameter 950 [Minor Flt Config] to enable. If not enabled, acts like a major fault.
Green/Red	Flashing Alternately	Drive is flash updating.	
ENET	None (Unlit)	Off	Adapter and/or network is not powered, adapter is not properly connected to the network, or adapter needs an IP address.
	Red	Flashing	An Ethernet/IP connection has timed out.
		Steady	Adapter failed the duplicate IP address detection test.
	Red/Green	Flashing Alternately	Adapter is performing a self-test.
	Green	Flashing	Adapter is properly connected but is not communicating with any devices on the network.
Steady		Adapter is properly connected and communicating on the network.	
LINK	None (Unlit)	Off	Adapter is not powered or is not transmitting on the network.
	Green	Flashing	Adapter is properly connected and transmitting data packets on the network.
		Steady	Adapter is properly connected but is not transmitting on the network.

NOTES:

1. A Type 1 alarm indicates that a condition exists. Type 1 alarms are user configurable.
2. A Type 2 alarm indicates that a configuration error exists and the drive cannot be started. Type 2 alarms are not configurable.

VERIFYING THAT DC BUS CAPACITORS ARE DISCHARGED

The drive's DC bus capacitors retain hazardous voltages after input power has been disconnected. Perform the following steps before touching any internal components:

1. Turn off and lock out input power. Wait 5 minutes.
2. Verify that there is no voltage at the drive's input power terminals.
3. Measure the DC bus potential with a voltmeter while standing on a non-conductive surface and wearing insulated gloves (1000 v). Measure the DC bus potential. See Fig. 6 for the 248-amp drive and Fig. 7 for the 289, 361, and 477-amp drives. The voltage between DC+ and DC-, and from each DC terminal to the chassis must be zero before proceeding.
4. Once the drive has been serviced, reapply input power.

HIGH TEMPERATURE ALARMS

Coolant flow through the cold plate is controlled by an orifice in the refrigerant line leaving the cold plate. The orifice looks like one of the O-ring face seal connectors and in fact is used as one of the connections on the coolant tubing. If the orifice is present and condenser liquid flow is present, the liquid will flash to cooler temperature at the orifice. This temperature difference is great enough to be easily felt.

MAIN CONTROL BOARD (MCB) COMPONENTS

Figure 16 shows the drive module with the cover removed. To access the control boards, loosen the screw on the face of the keypad mount and swing the keypad mount upward.

The components on the main control board (MCB) are shown in Fig. 17. Note the location of the terminals labeled MCB I/O. The high-pressure switch is wired to these terminals as shown in Fig. 18. In the event of a high condenser pressure alarm, the connections at these terminals should be checked and tightened if necessary.

Typical wiring schematics are shown in Appendix A.

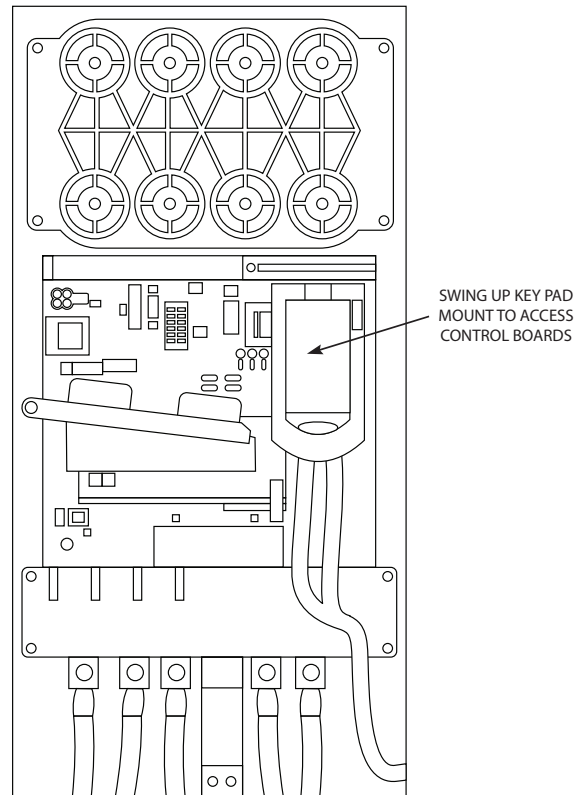

Fig. 16 — Drive Module with Cover Removed

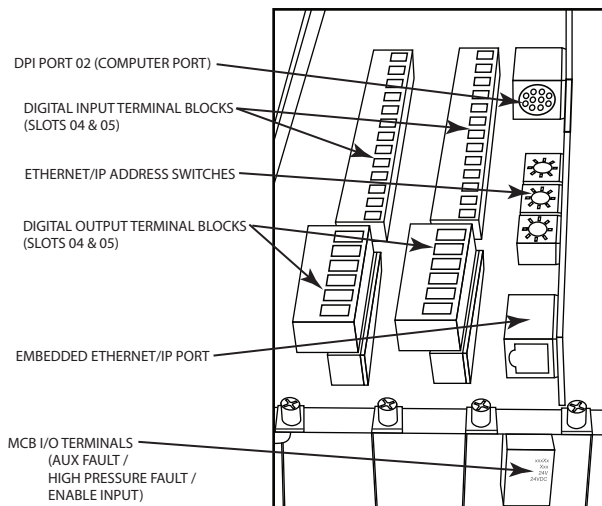
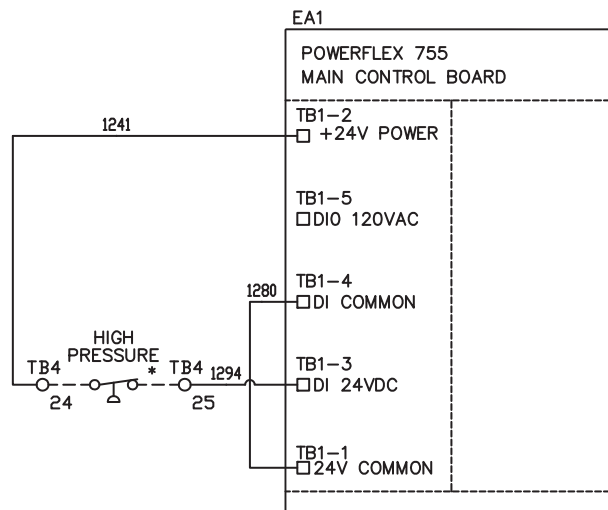

Fig. 17 — MCB (Main Control Board) Components



*Located outside of starter; connected by field wiring.

Fig. 18 — High-Pressure Switch Wiring

Table 5 — Powerflex 755 Fault Code Descriptions and Corrective Actions

VFD FAULT CODE ON VFD HIST SCREEN	ICVC FAULT STATE	PIC6 FAULT STATE	FAULT TYPE	DESCRIPTION	CORRECTIVE ACTION
NONE	206	449		Processor memory fault	Consult VFD manual to resolve generic fault.
0			No Entry		
2	207	439	Auxiliary Input	Input is open.	Check Compressor Discharge High Pressure switch wiring and accuracy. Check for high condenser water temperatures, low water flow, fouled tubes. Check for division plate/gasket bypass. Check for noncondensables in refrigerant.
3	210	425	Power Loss	Line voltage dropout	Temporary loss of voltage. Disable Single Cycle Dropout in VFD_CONF (PIC III)/CFGUMVFD (PIC6) screen.
4	215	429	Undervoltage	Low DC bus voltage	Verify phase-to-phase and phase-to-ground line voltage. VFD Circuit Board malfunction. Contact Carrier Service.
5	205 (166)	430	Overvoltage	High DC bus voltage	Verify phase to phase and phase to ground line voltage. Monitor AC line for high transient voltage conditions.
7	217	434	Motor Overload	An internal electronic overload trip has occurred.	Any phase current > 106% RLA. Can result from significant load side current imbalance when running at full load. Check entering condenser water temperature and water flow rate. Check Motor Rated Load Amps in VFD_CONF (PICIII)/CFGUMVFD (PIC6) screen.
8	219	444	Heat Sink Overtemp	Heat sink temperature has exceeded maximum operating temperature.	Check that VFD refrigerant isolation valves are open. Check VFD refrigerant cooling orifice and refrigerant strainer. Check for proper VFD cooling fan operation and air flow blockage.
9	219	444	Transistor Overtemp	The output transistors have exceeded maximum operating temperature.	Check that VFD refrigerant isolation valves are open. Check VFD refrigerant cooling orifice and refrigerant strainer. Check for proper VFD cooling fan operation and air flow blockage.
12	286	438	HW Overcurrent	The drive output current has exceeded hardware current limit.	Check for high entering water temperature or low condenser water flow. Check current settings in VFD_CONF (PIC III)/CFGUMVFD (PIC 6) screen.
13	220	432	Ground Fault	A current path to earth ground greater than 25% of drive rating has occurred.	Check the motor, motor terminals, and external wiring to the drive output terminals for a grounded condition.
14	206	432	Ground Warning	The ground current has exceeded the level set in P467.	—

Table 5 — Powerflex 755 Fault Code Descriptions and Corrective Actions (cont)

VFD FAULT CODE ON VFD HIST SCREEN	ICVC FAULT STATE	PIC6 FAULT STATE	FAULT TYPE	DESCRIPTION	CORRECTIVE ACTION
15	206	449	Load Loss	If this fault appears, there may be a problem with software configuration.	To reset the processor, cycle power to chiller, check VFD_CONF settings and save settings when exiting VFD_CONF (PIC3)/CFGUMVFD (PIC6) configuration screen. Check VFD parameters with Drive Explorer.
17	216	446	The DC bus ripple has exceeded a preset level.	Line Voltage imbalance	Check phase-to-phase and phase-to-ground distribution bus voltage. Increase Line Voltage % Imbalance in VFD_CONF (PIC3)/CFGUMVFD (PIC6) screen.
20	206	449	TorqPrv Spd Band	See VFD Fault Code 15	See VFD Fault Code 15
21	225	445	Output PhaseLoss	The current in one or more phases has been lost or remains below a preset level.	Check Motor Current % Imbalance in VFD_CONF (PIC3)/CFGUMVFD (PIC6) screen.
24	204	442	Decel Inhibit	The drive is not following a commanded deceleration because it is attempting to limit bus voltage.	Verify input voltage is within drive specified limits. Verify system ground impedance follows proper grounding techniques. Disable bus regulation P186 and/or add dynamic brake resistor and/or extend deceleration time P537 and P538.
33	206	449	AuRsts Exhausted	See VFD Fault Code 15	See VFD Fault Code 15
36	286	438	SW Overcurrent	The drive output current has exceeded the 1 ms current rating.	Check for excess load, improper DC boost setting, DC brake volts set too high.
38	220	432	Phase U to Gnd	GROUND FAULT	Check wiring between drive and motor. Check motor for grounded phase. Check motor terminals. Replace drive.
39			Phase V to Gnd		
40			Phase W to Gnd		
41	220	449	Phase UV Short	GROUND FAULT	Check wiring between drive and motor. Check motor terminals. Replace drive.
42			Phase VW Short		
43			Phase WU Short		
44	206	432	Phase UNot	GROUND FAULT (no LF2 equivalent)	Check wiring between drive and motor. Check motor terminals. Replace drive.
45	206	432	Phase VNot		
46	206	432	Phase WNot		
55	NONE	444	Ctrl Bd Inverter Overtemp	The temperature sensor on the main control board detected excessive heat.	Check that VFD refrigerant isolation valves are open. Check VFD refrigerant strainer.
61	206	449	Shear Pin 1	See VFD Fault Code 15	See VFD Fault Code 15
62	206	449	Shear Pin 2	See VFD Fault Code 15	See VFD Fault Code 15
64	206	449	Drive Overload	Drive is overloaded.	Check for high entering water temperature or low condenser water flow. Check current settings in VFD_CONF (PIC3)/CFGUMVFD (PIC6) screen.
77	206	449	IR Volts Range	See VFD Fault Code 15	See VFD Fault Code 15
78	206	449	FluxAmpsRef Rang	See VFD Fault Code 15	See VFD Fault Code 15
79	206	449	Excessive Load	Motor did not come up to speed in the allotted time.	Check that guide vanes are closed completely. Check for high entering water temperature or low condenser flow. Repeat Autotune
80	206	449	AutoTune Aborted	See VFD Fault Code 15	See VFD Fault Code 15
87	206	449	IXo VoltageRange	Ixo voltage calculated from motor nameplate data is too high.	Re-enter motor nameplate data in VFD_CONF (PIC3)/CFGUMVFD (PIC6) screen.
91	206	449	Pri VelFdbk Loss	See VFD Fault Code 15	See VFD Fault Code 15
93	206	449	HW Enable Check	See VFD Fault Code 15	See VFD Fault Code 15
94	206	449	Alt VelFdbk Loss	See VFD Fault Code 15	See VFD Fault Code 15
95	206	449	Aux VelFdbk Loss	See VFD Fault Code 15	See VFD Fault Code 15
96	206	449	PositionFdbkLoss	See VFD Fault Code 15	See VFD Fault Code 15
97	206	449	Auto Tach Switch	See VFD Fault Code 15	See VFD Fault Code 15
100	206	451	Parameter Chksum	The checksum read from the board does not match the checksum calculated.	Press ICVC reset (PIC3)/Reset alarm (PIC6). Check VFD_CONF parameters. Cycle power to the drive.
106	284	453	Incompat MCB-PB	The main control board did not recognize the power structure.	Flash with newer Application version software.
107	NONE	451	Replaced MCB-PB	The main control board was moved to a different power structure. Data set to default values.	Press ICVC reset (PIC3)/Reset alarm (PIC6). Check VFD_CONF (PIC3)/CFGUMVFD (PIC6) parameters. Cycle power to the drive.
113	206	451	Tracking DataErr	Internal data error	Press ICVC reset (PIC3)/Reset alarm (PIC6). Cycle power to the drive.
124	206	451	App ID Changed	Application firmware changed.	Verify application version.

Table 5 — Powerflex 755 Fault Code Descriptions and Corrective Actions (cont)

VFD FAULT CODE ON VFD HIST SCREEN	ICVC FAULT STATE	PIC6 FAULT STATE	FAULT TYPE	DESCRIPTION	CORRECTIVE ACTION
141	206	449	Autn Enc Angle	P78 [EncdrIss AngComp] is out of range.	See VFD Fault Code 15
142	206	449	Autn Spd Rstrct	See VFD Fault Code 15	See VFD Fault Code 15
143	206	449	Autotune CurReg	See VFD Fault Code 15	See VFD Fault Code 15
144	206	449	Autotune Inertia	See VFD Fault Code 15	See VFD Fault Code 15
145	206	449	Autotune Travel	See VFD Fault Code 15	See VFD Fault Code 15
168	206	444	HeatSinkUnder-Tmp	Heatsink temperature sensor is reporting a value below -18.7 C (-1.66 F) or the sensor feedback circuit is open.	Check heat sink temperature sensor. Check heat sink temperature.
210	206	449	HW En Jumper Out	See VFD Fault Code 15	See VFD Fault Code 15
211	206	449	Safety Brd Fault	See VFD Fault Code 15	See VFD Fault Code 15
213	206	449	Safety Jumper In	See VFD Fault Code 15	See VFD Fault Code 15
226	224	448	VFD Comm loss	The device at the port has stopped communicating with the main control board.	Verify that the device is present and functional. Verify network connections. Verify options installed in appropriate ports are seated in the port and secured with mounting screws.
291	206	449	HSFan Lifwe	See VFD Fault Code 15	See VFD Fault Code 15
292	206	449	InFan Life	See VFD Fault Code 15	See VFD Fault Code 15
293	206	449	MtrBrg Life	See VFD Fault Code 15	See VFD Fault Code 15
294	206	449	MtrBrg Lube	See VFD Fault Code 15	See VFD Fault Code 15
295	206	449	MachBrg life	See VFD Fault Code 15	See VFD Fault Code 15
296	206	449	MachBrg Lube	See VFD Fault Code 15	See VFD Fault Code 15
315	206	449	Excess Psn Error	See VFD Fault Code 15	See VFD Fault Code 15
351	209	426	In Cur Share L1	There is an input current sharing imbalance between parallel converters in the AC line indicated that is greater than 15% of the converter rated current	See VFD Fault Code 15
352	209	426	In Cur Share L2	There is an input current sharing imbalance between parallel converters in the AC line indicated that is greater than 15% of the converter rated current	See VFD Fault Code 15
353	209	426	In Cur Share L3	There is an input current sharing imbalance between parallel converters in the AC line indicated that is greater than 15% of the converter rated current	See VFD Fault Code 15

Checking Power Modules and Motor Input with Input Power Off

Use the following procedure to check the drive's power module circuitry with power off:

1. Turn off and lock out input power. Wait 5 minutes.
2. Verify there is no voltage at the drive's input power terminals.
3. Using a voltmeter, check the DC bus potential as described in the section Verifying That DC Bus Capacitors Are Discharged on page 11 to ensure the DC bus capacitors are discharged.
4. Disconnect the motor from the drive.
5. Check all AC line and DC bus fuses.
6. Use a multimeter to check the input diodes and output IGBTs if a fuse is open. See Table 6.
7. Check motor impedance.
8. Reconnect the motor to the drive.
9. Reapply input power.

WARNING

DC bus capacitors retain hazardous voltages after input power has been disconnected. After disconnecting input power, wait five (5) minutes for the DC bus capacitors to discharge and then check the voltage with a voltmeter to ensure the DC bus capacitors are discharged before touching any internal components. Confirm that the DC bus has discharged before performing diode checks. Failure to observe this precaution could result in severe bodily injury or loss of life.

Table 6 — Diode Checks

METER LEAD		METER READING
(+)	(-)	
R	DC+	0.5 v
	DC-	Infinite (OL)
S	DC+	0.5 v
	DC-	Infinite (OL)
T	DC+	0.5 v
	DC-	Infinite (OL)
U	DC+	0.5 v
	DC-	infinite (OL)
V	DC+	0.5 v
	DC-	Infinite (OL)
W	DC+	0.5 v
	DC-	Infinite (OL)
DC+	R	Infinite (OL)
	S	
	T	
	U	
	V	
DC-	R	0.5 v
	S	
	T	
	U	
	V	

NOTE: Digital meters require a special diode check function because the current sourced by the meter during a normal resistance (Ohms) test is too low to accurately test a diode. Make sure the meter is set to the diode test function. Voltage readings may not be exact as shown in above table, but look for consistency during each of the 4 tests. When performing a test that should return infinity (OL) as shown in above table, you may see a value slowly climbing toward infinity. This is a result of the meter charging a capacitor and is normal.

Servicing the Drive

⚠ WARNING

To guard against possible personal injury and/or equipment damage:

1. Inspect all lifting hardware for proper attachment before lifting drive.
2. Do not allow any part of the drive or lifting mechanism to make contact with electrically charged conductors or components.
3. Do not subject the drive to high rates of acceleration or deceleration while transporting to the mounting location or when lifting.

Do not allow personnel or their limbs directly underneath the drive when it is being lifted and mounted.

⚠ WARNING

DC bus capacitors retain hazardous voltages after input power has been disconnected. After disconnecting input power, wait five (5) minutes for the DC bus capacitors to discharge and then check the voltage with a voltmeter to ensure the DC bus capacitors are discharged before touching any internal components. Failure to observe this precaution could result in severe bodily injury or loss of life.

1. Using recommended screwdriver (6.4 mm [0.25 in.] flat or T20 star), open access door. See Fig. 19.

2. Check to be sure that the voltage between DC+ and DC- and from each DC terminal to the chassis is zero before proceeding. See Fig. 20.
3. Remove the enclosure. See Fig. 21.

REMOVING THE DRIVE

The dimensions and weights specified must be taken into consideration when removing the drive. All lifting equipment and lifting components (hooks, bolts, lifts, slings, chains, etc.) must be properly sized and rated to safely lift and hold the weight of the drive while removing it. For 19XRV chillers, see Fig. 22. For 23XRV chillers, see Fig. 23. The drive weights are as follows:

- Drive weight for Frame 6: 85 lb.
- Drive weight for Frame 7: 160 - 249 lb.

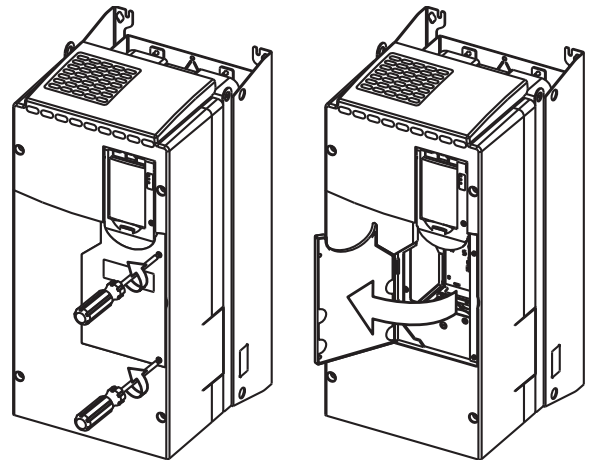

Fig. 19 — Open Access Door

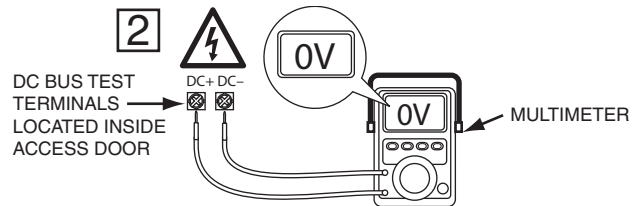
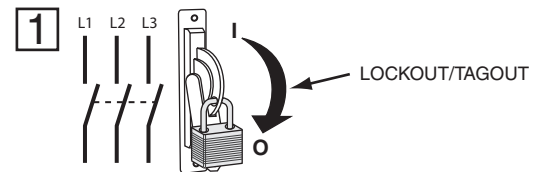

Fig. 20 — Check DC Bus Terminals

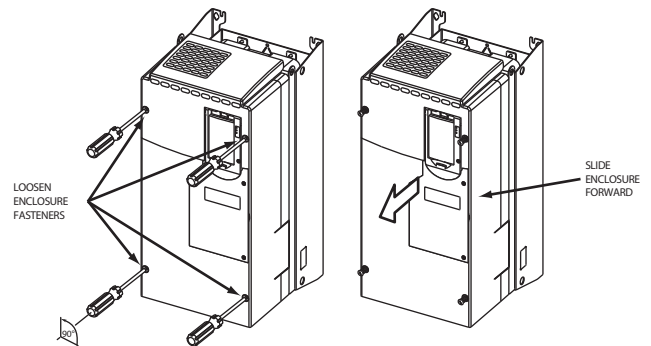

Fig. 21 — Removing Enclosure

When replacing the drive, reverse the procedures and tighten to the torques for Frames 6 and 7 power terminal block listed in Table 7.

Table 7 — Frames 6 and 7 Power Terminal Block

FRAME	MAXIMUM LUG WIDTH	RECOMMENDED TORQUE	TERMINAL BOLT SIZE
6	34.6 mm (1.36 in.)	11.3 N·m (100 in.-lb)	M8 x 1.25
7	43.5 mm (1.71 in.)	11.3 N·m (100 in.-lb)	M8 x 1.25

RIGGING THE ENCLOSURE

Where overhead room and/or clearance in front of the drive enclosure is insufficient to allow the drive to be safely removed from the enclosure, the entire enclosure may have to be removed from the chiller.

The dimensions and weights specified must be taken into consideration when removing the enclosure. For 19XRV chillers, the total weight for Frames 6 and 7, including drive weight and enclosure, is 720 lb. The 23XRV chiller enclosure, including all components, weighs 975 lb. All lifting equipment and lifting components (hooks, bolts, lifts, slings, chains, etc.) must be properly sized and rated to safely lift and hold the weight of the enclosure and drive while removing. See Fig. 24 and Fig. 25.

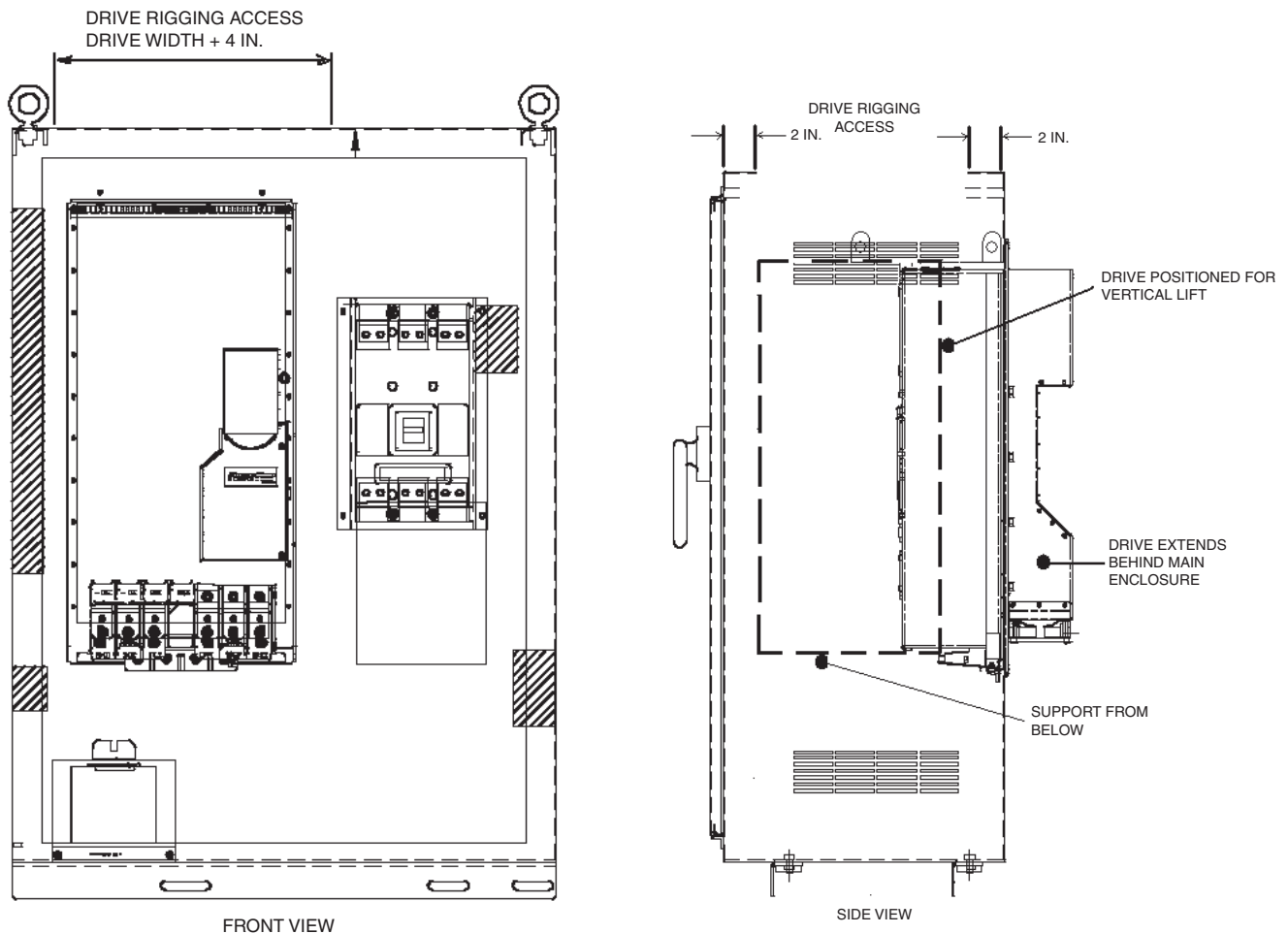

Fig. 22 — 19XRV Enclosure Access for Removing Drive

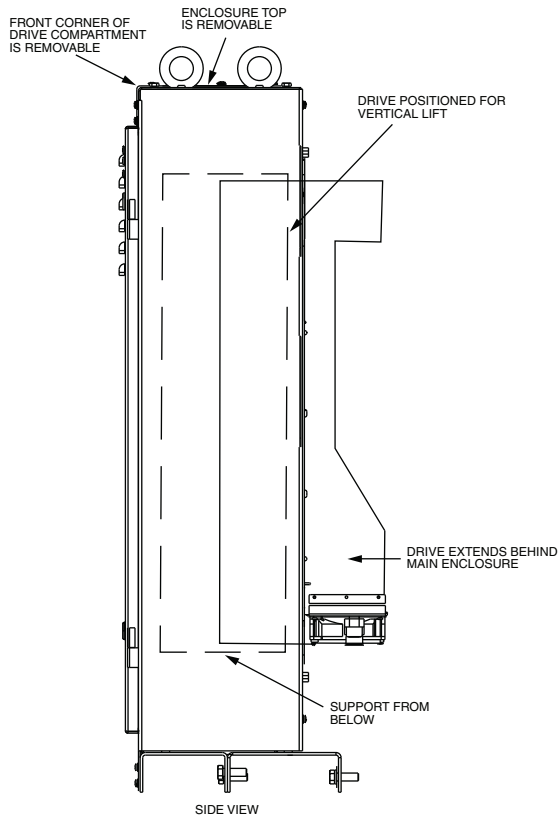

Fig. 23 — 23XRV Enclosure Access for Removing Drive

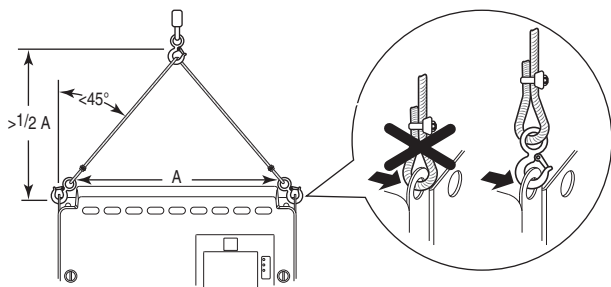

Fig. 24 — Rigging the Enclosure, Frame 6

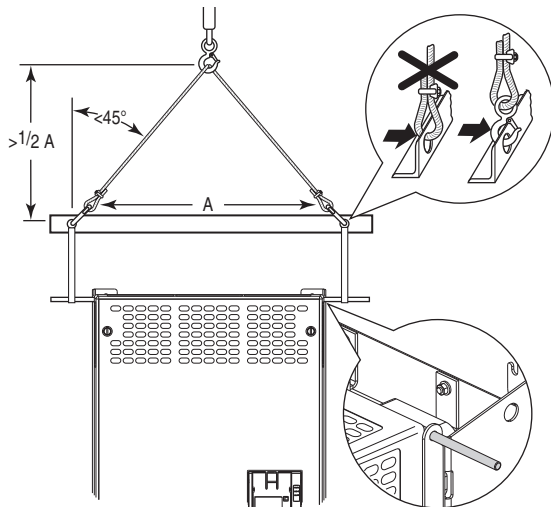

Fig. 25 — Rigging the Enclosure, Frame 7

REPLACING THE GATEWAY (A-B20-750-20COMM PIC3 / 20-COMM-H (PIC6) OPTION CARD)

Follow these steps for removing and replacing the existing gateway:

1. Disconnect power to the drive. Before removing the enclosure, open the access door on the front of the drive. See Fig. 19.
2. Check to be sure that the voltage between DC+ and DC- and from each DC terminal to the chassis is zero before proceeding. See Fig. 20.
3. Remove the enclosure. See Fig. 21.
4. Remove the 2 screws securing the mounting plate and remove the mounting plate and COMM card. See Fig. 26.
5. Mount the new COMM card and mounting plate and attach with the 2 screws removed in Step 4. See Fig. 27.
6. Use the shorter ribbon cable to connect the plug on the COMM card to the connector on the mounting plate. See Fig. 26.
7. Install the enclosure. See Fig. 21.

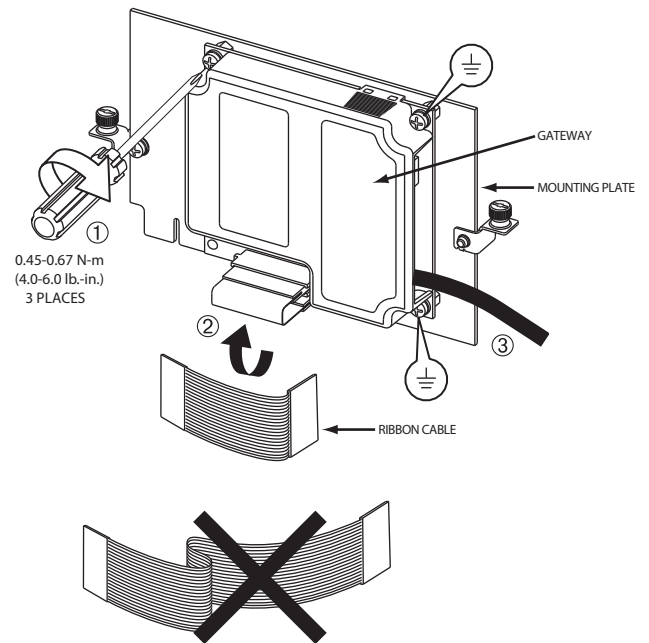

Fig. 26 — COMM Card

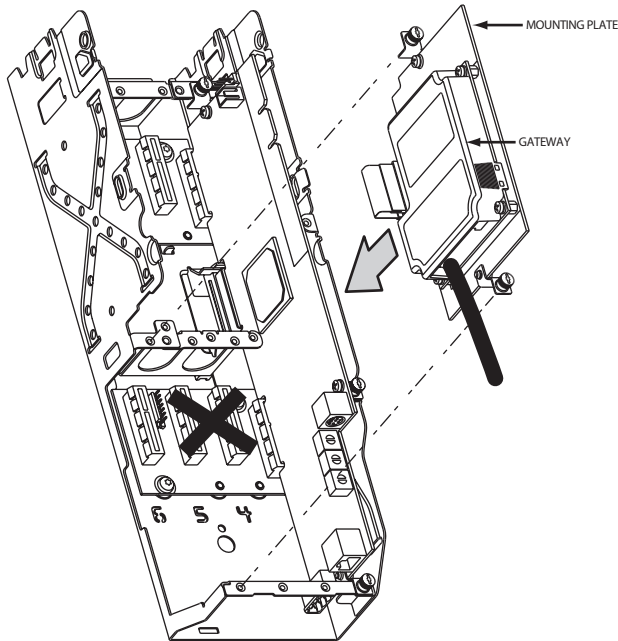

Fig. 27 — Mount COMM Card Plate to Drive

CHILL PLATE FAN AND INTERNAL FAN REPLACEMENT

Follow these steps to replace the chill plate fan and internal fan in Frames 6 and 7.

Frame 6 (chill plate fan kit Z1P-FAN-A6-A):

1. Disconnect power to the drive. Before removing the enclosure, open the access door on the front of the drive. See Fig. 19.
2. Check to be sure that the voltage between DC+ and DC- and from each DC terminal to the chassis is zero before proceeding. See Fig. 20.
3. Remove the enclosure. See Fig. 21.
4. Remove and replace the chill plate fan. See Fig. 28.
5. Remove and replace the internal fan. See Fig. 29.
6. Install the enclosure. See Fig. 21.

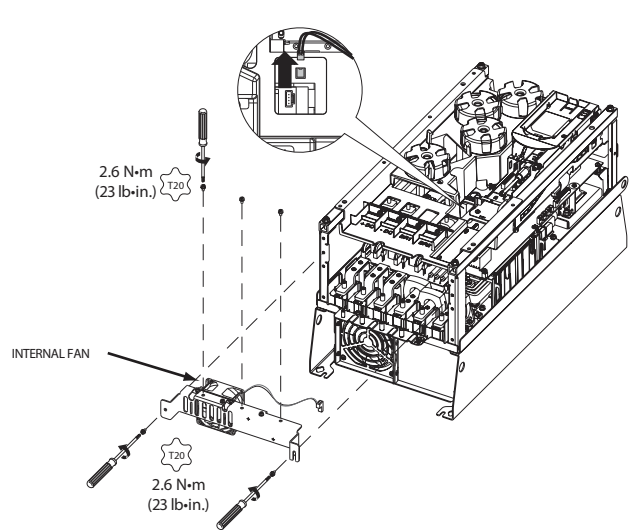

Fig. 29 — Internal Fan, Frame 6

Frame 7 (chill plate fan kit Z1P-FAN-A7-A):

1. Disconnect power to the drive. Before removing the enclosure, open the access door on the front of the drive. See Fig. 19.
2. Check to be sure that the voltage between DC+ and DC- and from each DC terminal to the chassis is zero before proceeding. See Fig. 20.
3. Remove the enclosure. See Fig. 21.
4. Remove and replace the chill plate and internal fans. See Fig. 30.
5. Install the enclosure. See Fig. 21.

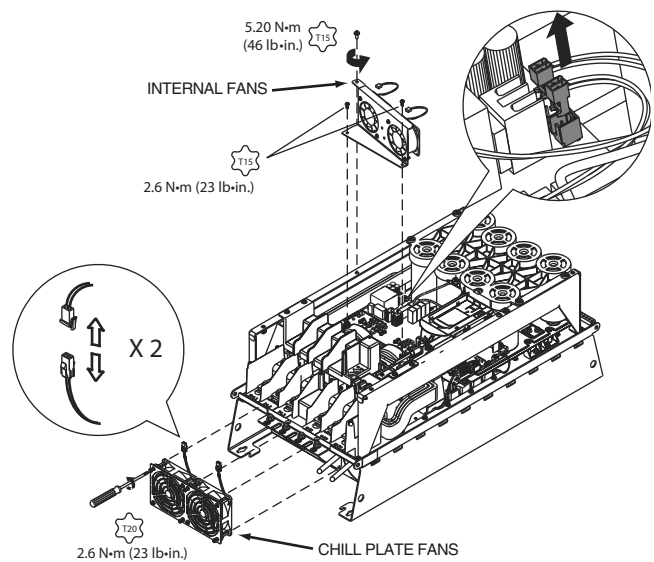

Fig. 30 — Chill Plate and Internal Fans, Removal and Replacement, Frame 7

Part Identification and Location

See Fig. 31-34 for parts descriptions and locations.

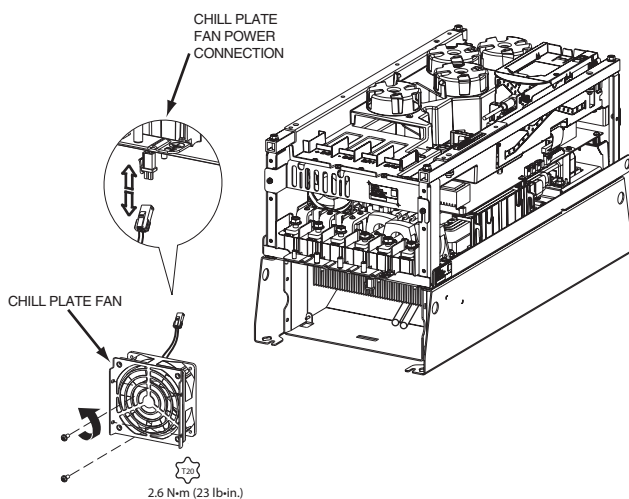

Fig. 28 — Chill Plate Fan, Frame 6

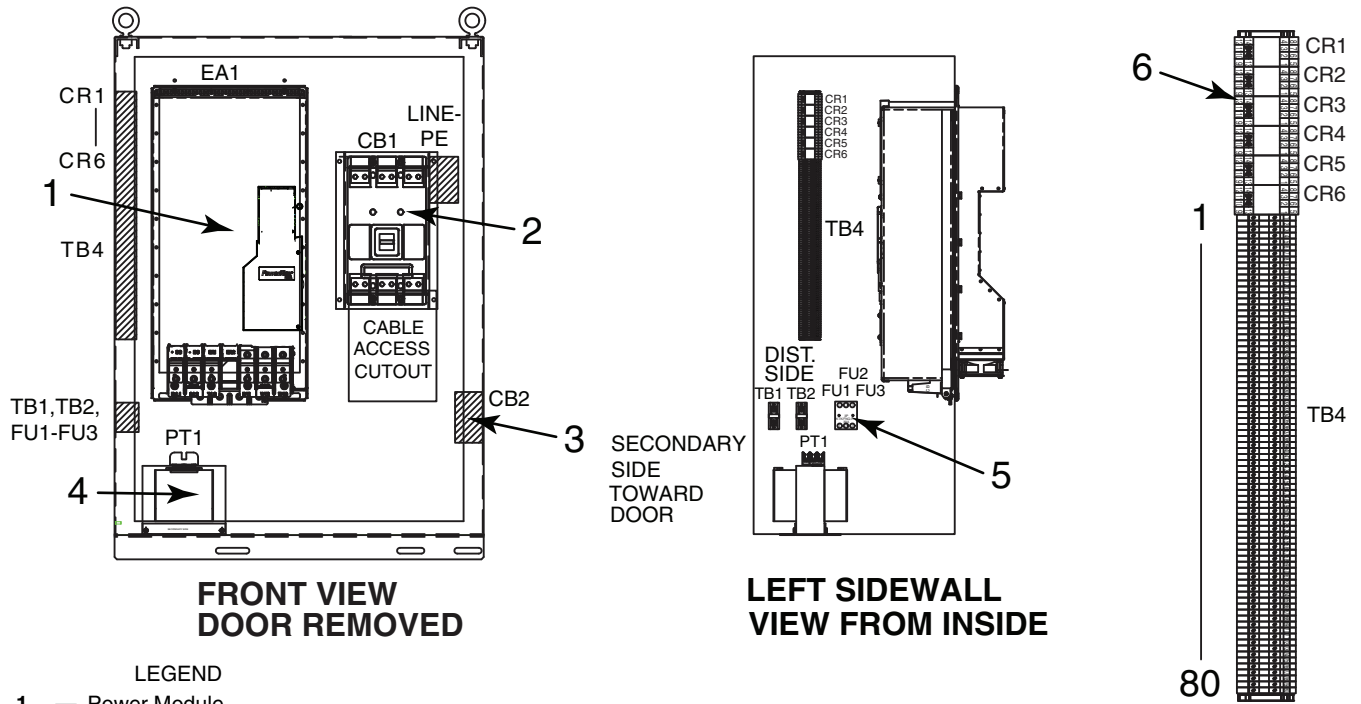

Fig. 31 — 19XRV Assembly Parts

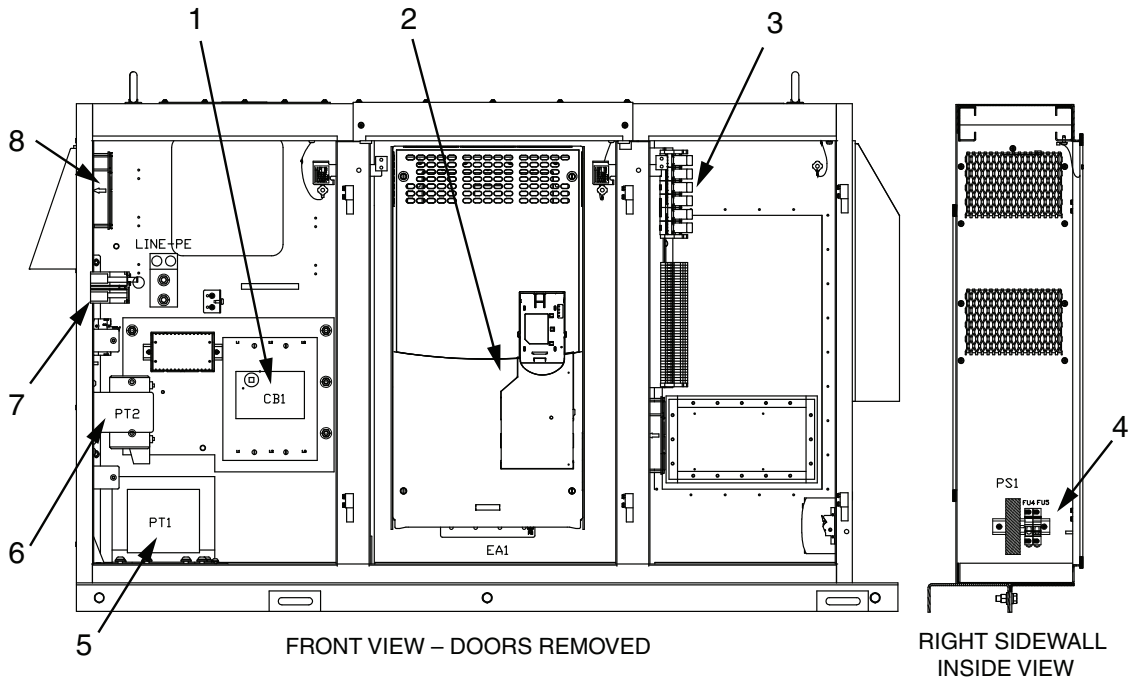
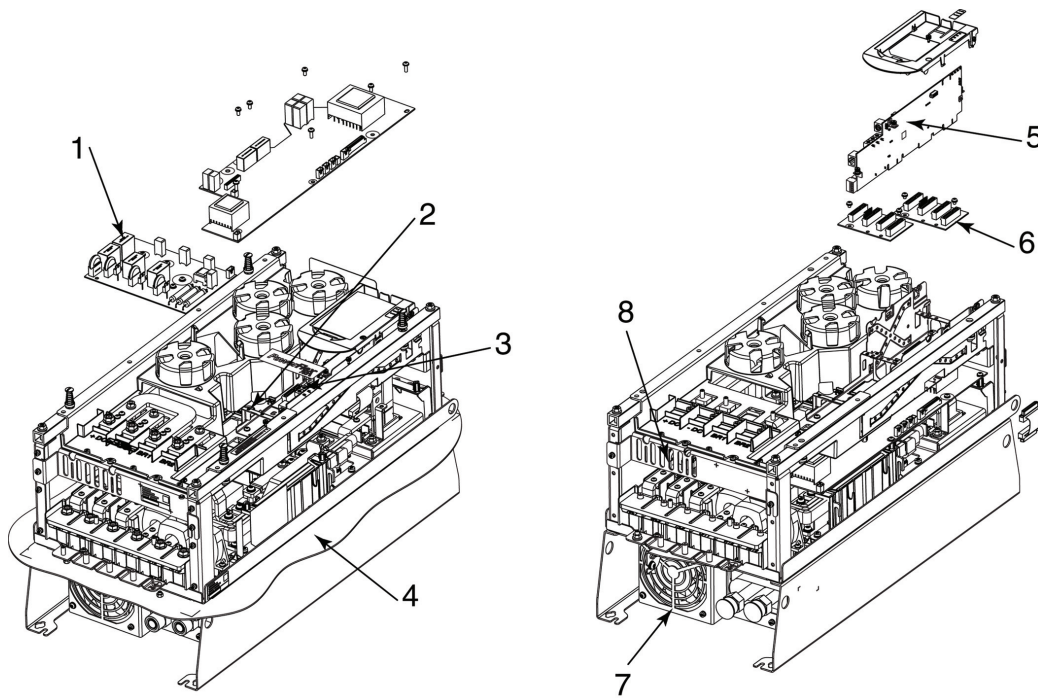

Fig. 32 — 23XRV Assembly Parts



NOTE: When replacing the Main Control Board (Item No. 5) the jumper marked "J1 HARDWARE ENABLE" must be removed and the jumper marked "J2 SAFETY ENABLE" must be left in place.

LEGEND

- 1 — PF750 Series, Precharge Kit
- 2 — PF750 Series, Gate Interface
- 3 — PF750 Series, Power Interface
- 4 — PowerFlex 750 Series, Flange Gasket
- 5 — PF755 Main Control Board
- 6 — PF750 Series, Backplane Interface
- 7 — PF750 Series, Type 4X/12 Chill Plate (Heatsink) Fan Kit
- 8 — Chill Plate Fan

Fig. 33 — Frame 6 Parts

LEGEND

- 1 — Slot for Gateway (Gateway Not Shown)
- 2 — PF750 Series, Backplane Interface
- 3 — PF750 Series, Type 4X/12 Heatsink Fan Kit
- 4 — PF750 Series, Power Interface
- 5 — PF750 Series, Bus Cap Assembly
- 6 — PF750 Series, Power Interface Cable
- 7 — PF750 Series, Current Transducer Kit
- 8 — PF750 Series, Precharge Kit
- 9 — Slot for 24 v I/O Module (24 v I/O Module Not Shown)
- 10 — PF755 Main Control Board

NOTE: When replacing the Main Control Board (Item No. 10) the jumper marked "J1 HARDWARE ENABLE" must be removed and the jumper marked "J2 SAFETY ENABLE" must be left in place.

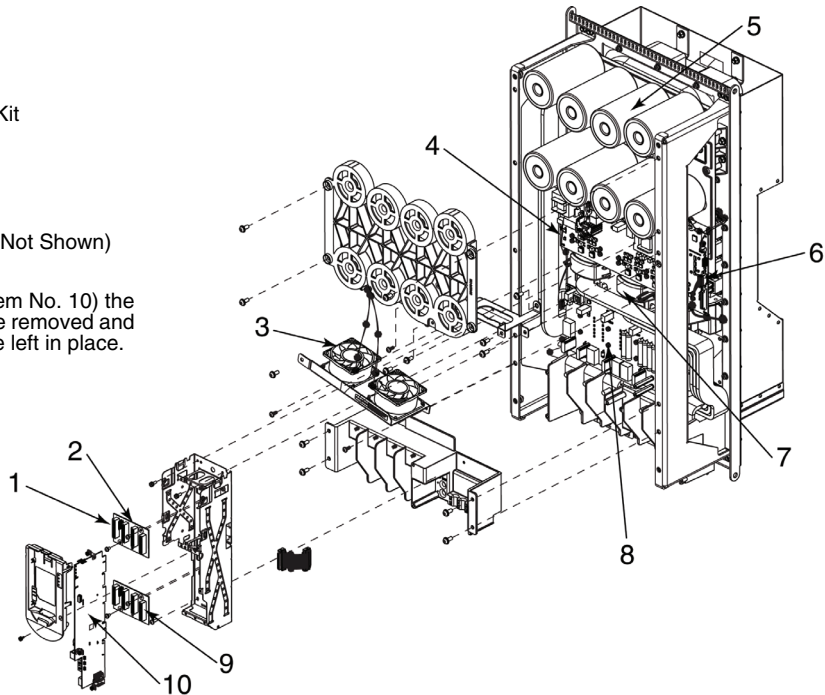
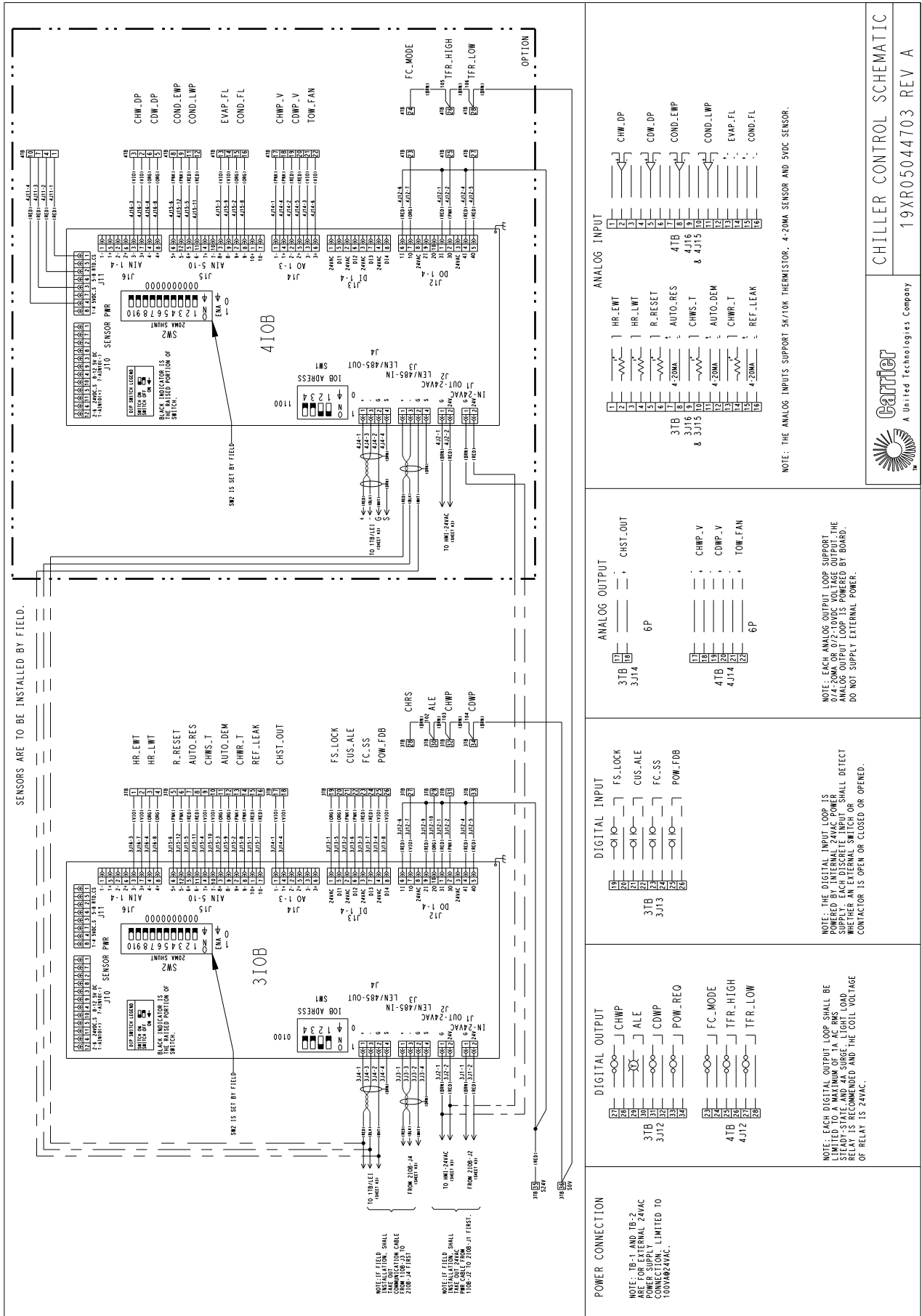

Fig. 34 — Frame 7 Parts

APPENDIX A — WIRING SCHEMATICS (cont)

19XRV CHILLER CONTROL SCHEMATIC (PIC 6) (cont)



APPENDIX A — WIRING SCHEMATICS (cont)

23XRV CHILLER CONTROL SCHEMATIC

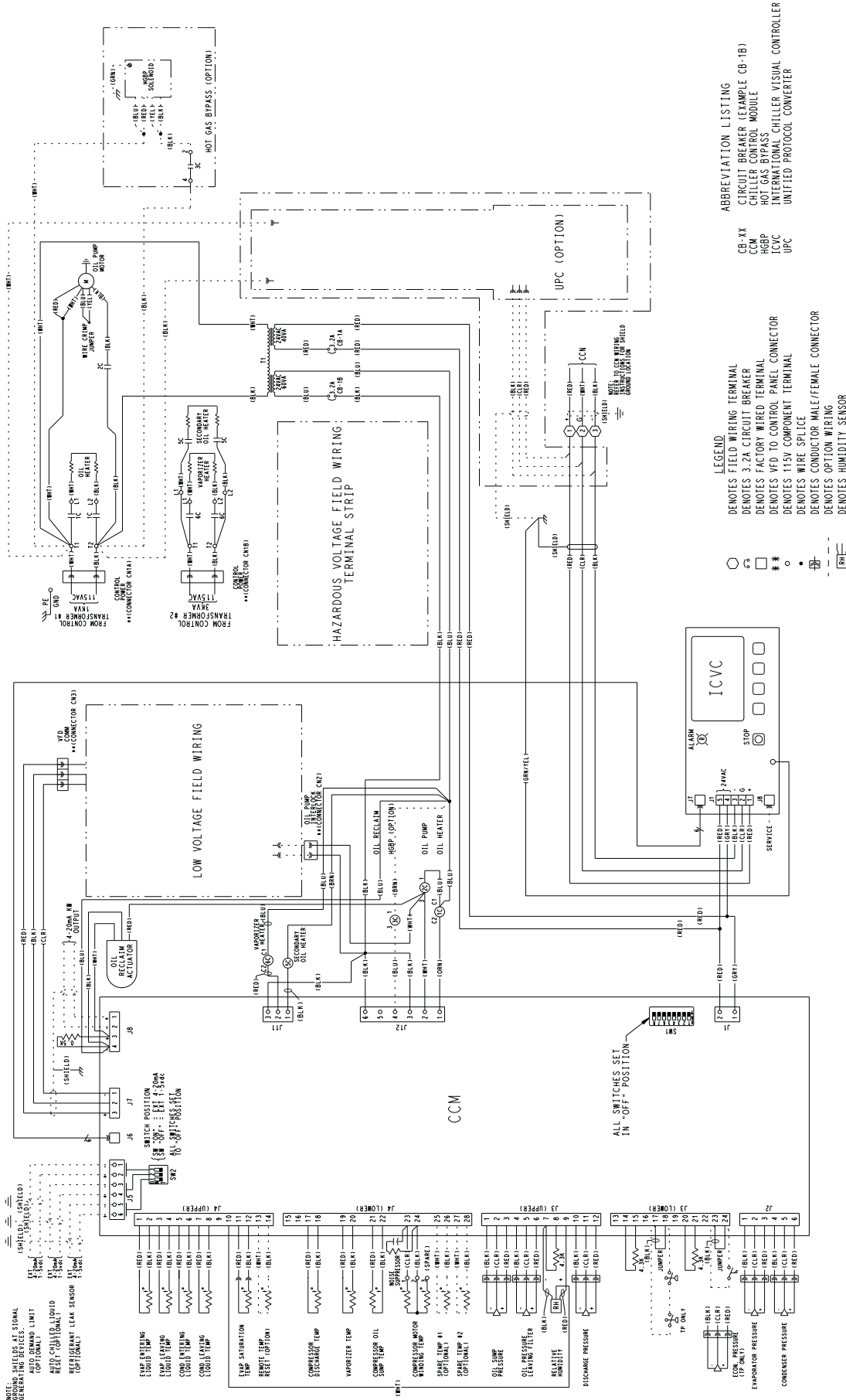

APPENDIX A — WIRING SCHEMATICS (cont)

ROCKWELL POWERFLEX 755 WIRING SCHEMATIC (Typical)

19XRV (Typical)

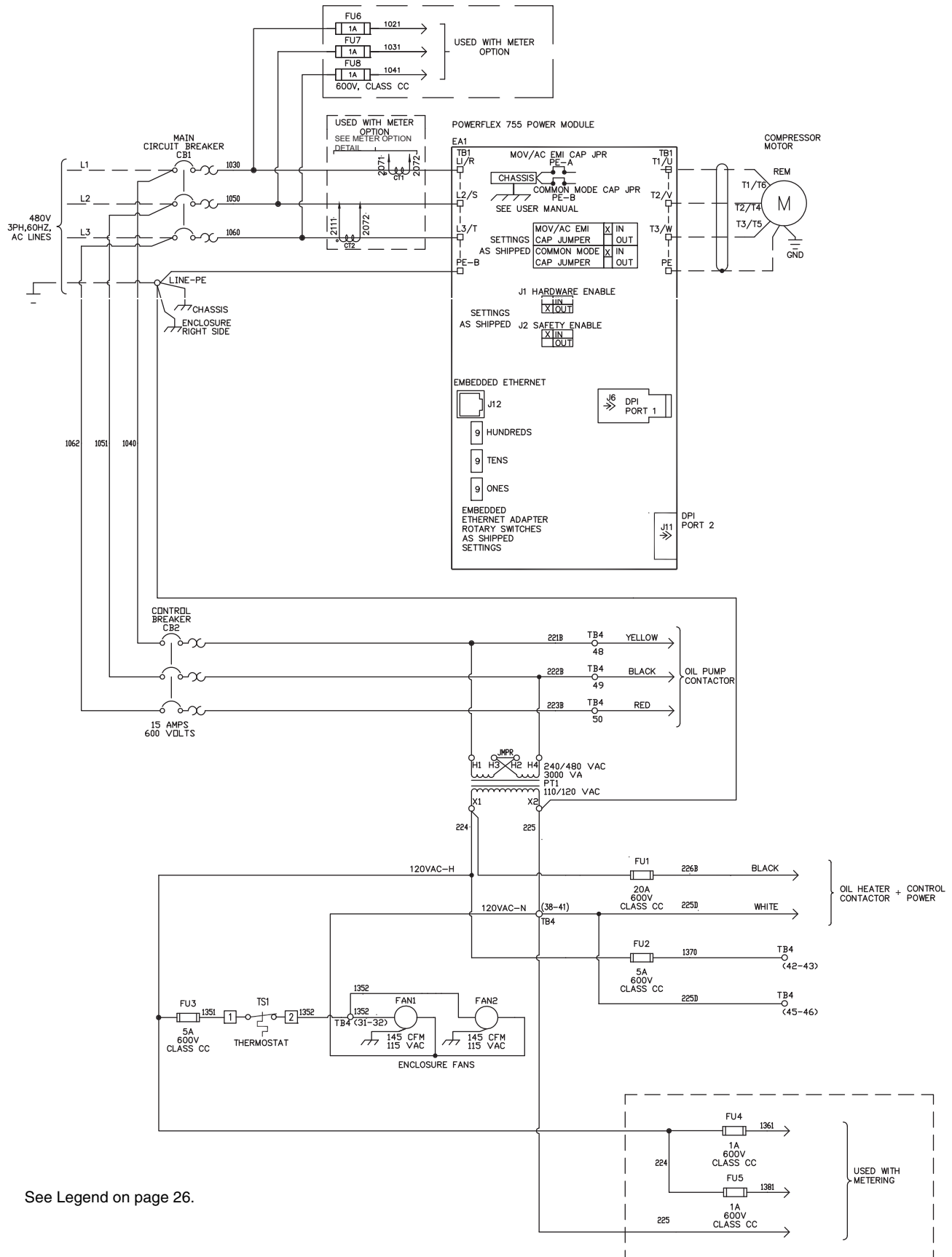

See Legend on page 26.

APPENDIX A — WIRING SCHEMATICS (cont)
ROCKWELL POWERFLEX 755 WIRING SCHEMATIC (Typical) (cont)
19XRV (Typical) (cont)

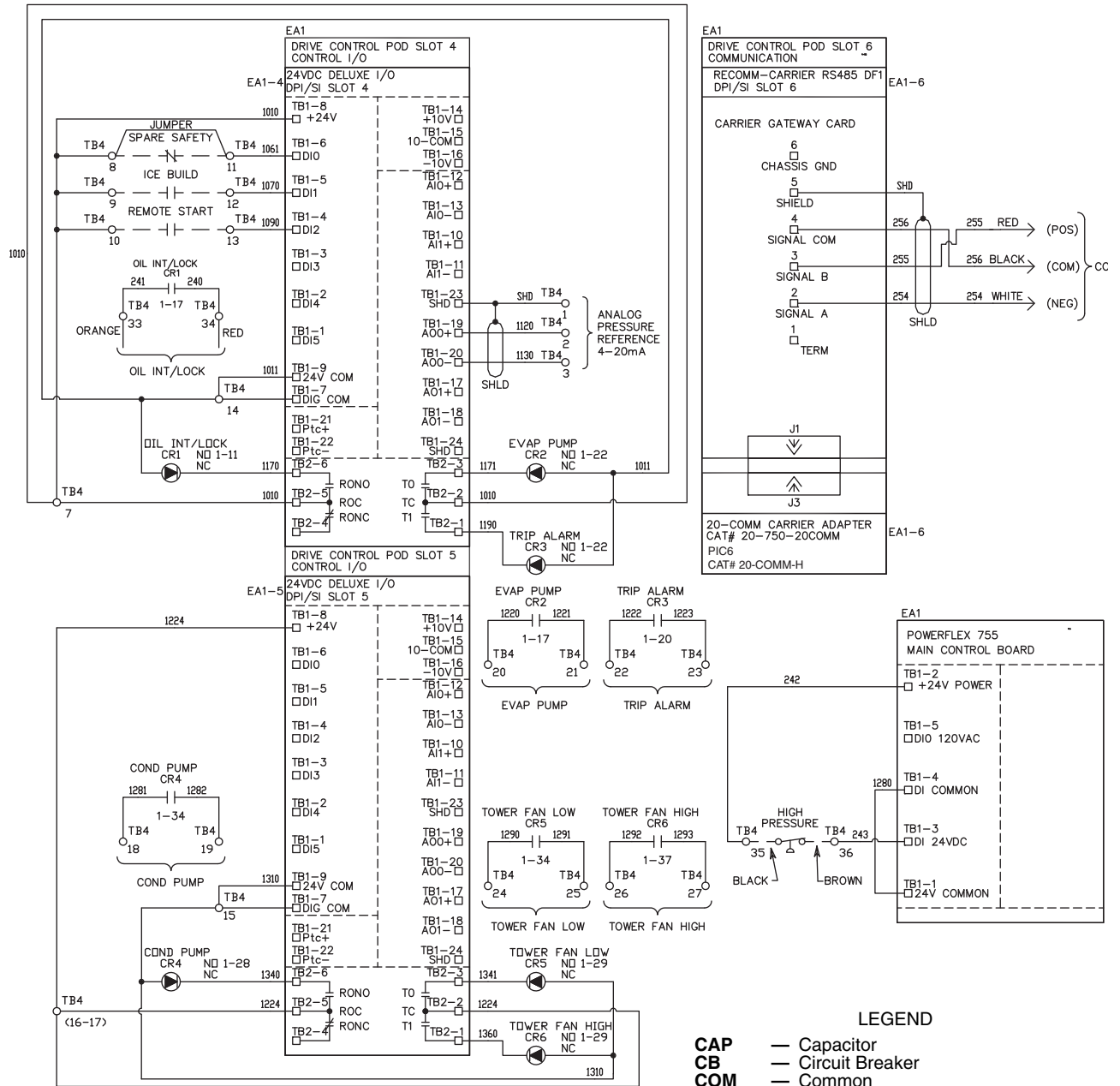

- LEGEND**
- CAP** — Capacitor
 - CB** — Circuit Breaker
 - COM** — Common
 - COMM** — Communication
 - COND** — Condenser
 - CR** — Control Relay
 - DPI/SI** — Internal Communication Protocols Connections
 - EA** — Electrical Assembly
 - EMI** — Electro-Magnetic Interference
 - EVAP** — Evaporator
 - FU** — Fuse
 - GND** — Ground
 - JMPR** — Jumper
 - M** — Motor
 - NC** — Normally Closed
 - NO** — Normally Open
 - PE** — Potential Earth (Ground)
 - POD** — I/O Card Mounting Board Slot
 - REM** — Remote
 - RO** — Relay Output
 - ROC** — Relay Output Common
 - SHLD** — Shield
 - TB** — Terminal Block

APPENDIX A — WIRING SCHEMATICS (cont)
ROCKWELL POWERFLEX 755 WIRING SCHEMATIC (Typical) (cont)
23XRV (Typical)

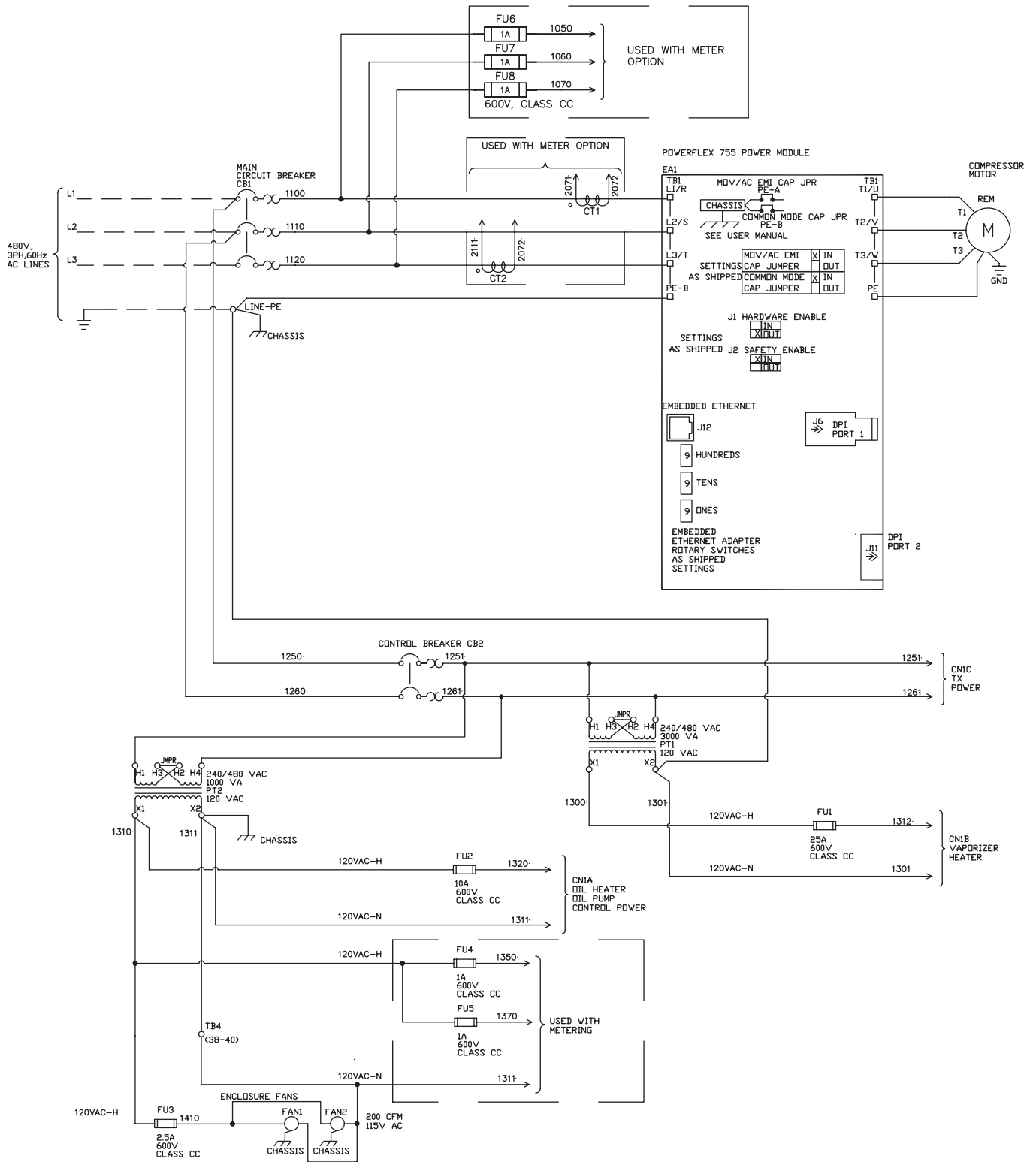

See Legend on page 28.

APPENDIX A — WIRING SCHEMATICS (cont)
ROCKWELL POWERFLEX 755 WIRING SCHEMATIC (Typical) (cont)
19XRV,23XRV METER OPTION

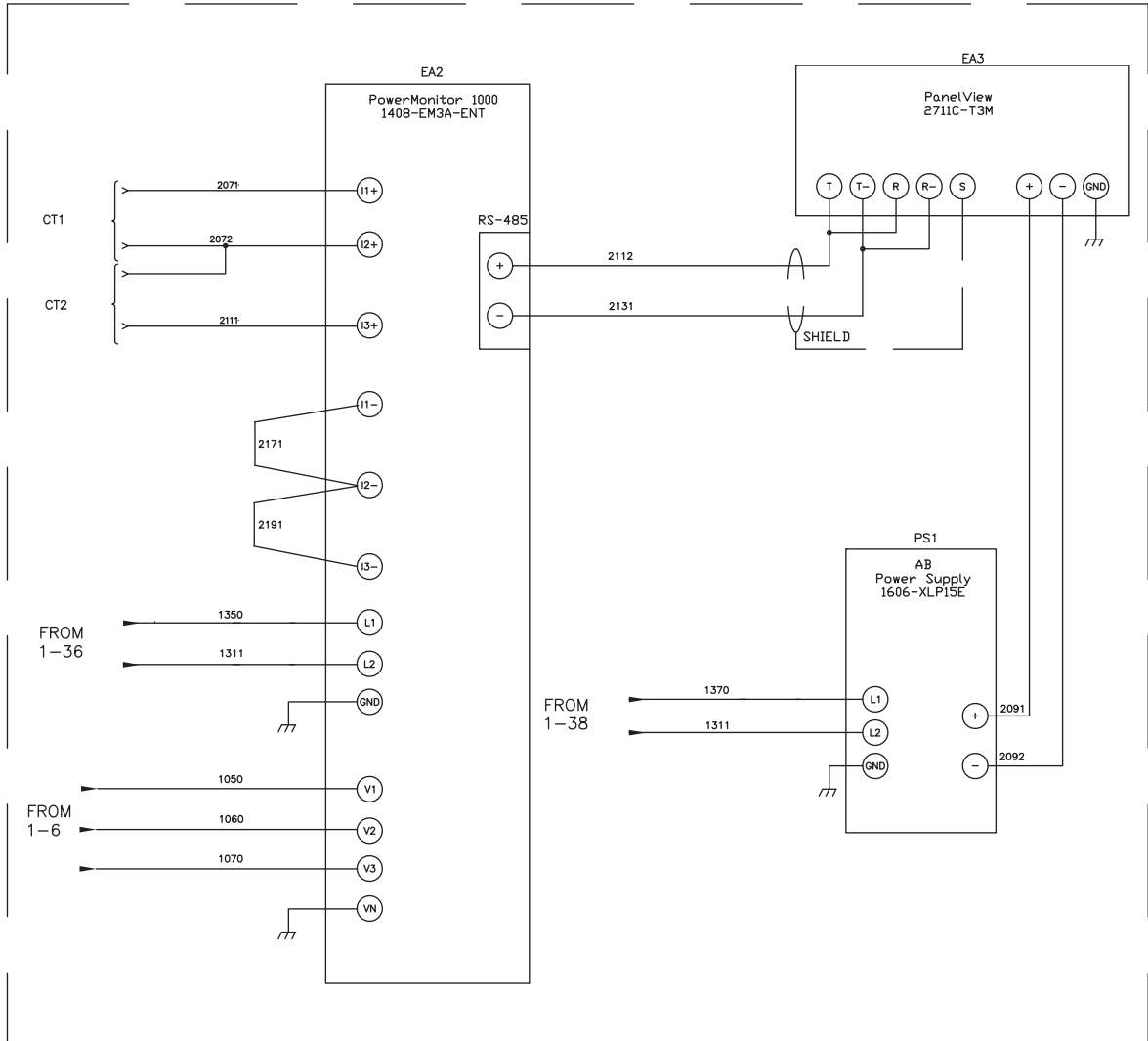

Free Manuals Download Website

<http://myh66.com>

<http://usermanuals.us>

<http://www.somanuals.com>

<http://www.4manuals.cc>

<http://www.manual-lib.com>

<http://www.404manual.com>

<http://www.luxmanual.com>

<http://aubethermostatmanual.com>

Golf course search by state

<http://golfingnear.com>

Email search by domain

<http://emailbydomain.com>

Auto manuals search

<http://auto.somanuals.com>

TV manuals search

<http://tv.somanuals.com>