



Installation, Start-Up and Service Instructions

CONTENTS

	Page
SAFETY CONSIDERATIONS	1
PRE-INSTALLATION	1,2
Moving and Storage	2
Rigging	2
INSTALLATION	2-25
General	2
Uncrating	2
Accessories	2
Unit Positioning	13
Unit Isolation	13
Refrigerant and Chilled Water	
Piping Access	13
Refrigerant Piping	13
Chilled Water Piping	19
Condensate Drain	20
Fan Motors and Drives	20
Power Supply and Wiring	21
Connecting Ductwork	24
Return-Air Filters	24
START-UP	25
SERVICE	25-45
Panels	25
Fan Motor Lubrication	25
Fan Shaft Bearings	25
Centering Fan Wheel	26
Fan Shaft Position Adjustment	26
Individual Fan Wheel Adjustment	26
Fan Belts	26
Fan Rotation	26
Fan Pulley Alignment	27
Pulley and Drive Adjustment	27
Condensate Drains	27
Return-Air Filters	27
Chilled Water Coil Freeze Protection	27
Coil Removal	27
Cleaning Cooling Coil	27
Cleaning Insulation	27
Replacing Filters	28
START-UP CHECKLIST	CL-1,CL-2

SAFETY CONSIDERATIONS

⚠ WARNING

Improper installation, adjustment, alteration, service, maintenance, or use can cause explosion, fire, electric shock, or other occurrences which may injure you or damage your property. Consult qualified installer or service agency for information or assistance. The qualified installer or agency must use only factory-authorized kits or accessories when modifying this product.

Recognize safety information. This is the safety-alert symbol (⚠). When you see this symbol on the unit and in instructions or manuals, be alert to the potential for personal injury.

Understand the signal words — DANGER, WARNING, and CAUTION. These words are used with the safety-alert symbol. Danger identifies the most serious hazards which will result in severe personal injury or death. Warning indicates a condition that could result in personal injury. Caution is used to identify unsafe practices which would result in minor personal injury or product and property damage.

Installing, starting up, and servicing this equipment can be hazardous due to system pressures, electrical components and equipment location (elevated structures, etc.).

Only trained, qualified installers and service mechanics should install, start up, and service this equipment.

Untrained personnel can perform basic maintenance functions such as cleaning coils, and cleaning and replacing filters. All other operations should be performed by trained service personnel.

When working on the equipment, observe precautions in the literature and on tags, stickers, and labels attached to the equipment.

- Follow all safety codes.
- Wear safety glasses and work gloves.
- Use care in handling, rigging, and setting bulky equipment.

⚠ WARNING

Be sure all power to equipment is shut off before performing maintenance or service. More than one disconnect may be present. Failure to do so may result in personal injury or damage to the unit.

PRE-INSTALLATION

1. The power supply (v, ph, and Hz) must correspond to that specified on unit rating plate.
2. The electrical supply provided by the utility must be sufficient to handle load imposed by this unit.
3. Refer to Installation, General section (page 2) and Fig. 1A-1C for locations of electrical inlets, condensate drain, duct connections, and required clearances before setting unit in place.
4. This installation must conform with local building codes and with the NEC (National Electrical Code) or ANSI (American National Standards Institute)/NFPA (National Fire Protection Association) latest revision. Refer to provincial and local plumbing or wastewater codes and other applicable local codes.

Moving and Storage — To transfer unit from truck to storage site, use a fork truck. Do not stack units more than 2 high during storage. If unit is to be stored for more than 2 weeks before installation, choose a level, dry storage site free from vibration. Do not remove plastic wrap or skid from unit until final installation.

Rigging — All 40RM Series units can be rigged by using the shipping skid. Units are shipped fully assembled. Do not remove shipping skids or protective covering until unit is ready for final placement; damage to bottom panels can result. Use slings and spreader bars as applicable to lift unit.

INSTALLATION

General — Allow 2¹/₂ ft at front and side of unit for service clearance and airflow. For units equipped with an economizer, refer to the accessory installation instructions for additional clearance requirements. Be sure floor, wall, or ceiling can

support unit weight (Tables 1A-1F). See Fig. 1A-1C for dimensions.

Uncrating — Move unit as near as possible to final location before removing shipping skid.

Remove metal banding, top skid, and plastic wrap. Examine unit for shipping damage. If shipping damage is evident, file claim with transportation agency. Remove base skid just prior to actual installation.

Check nameplate information against available power supply and model number description in Fig. 2.

NOTE: Be sure to remove the styrofoam shipping pad from the thermostatic expansion valve (TXV). Verify that it has been removed. See Fig. 3.

Accessories — Refer to instructions shipped with each accessory for specific information.

Table 1A — 40RM Physical Data, English — Cooling Units

UNIT 40RM	007	008	012	014	016	024	028	034
NOMINAL CAPACITY (Tons)	6	7 ¹ / ₂	10	12 ¹ / ₂	15	20	25	30
OPERATING WEIGHT (lb)								
Base Unit with TXV	381	385	405	670	685	690	1020	1030
Plenum	175	175	175	225	225	225	325	325
FANS								
Qty...Diam. (in.)	1...15	1...15	1...15	2...15	2...15	2...15	2...18	2...18
Nominal Airflow (cfm)	2400	3000	4000	5000	6000	8,000	10,000	12,000
Airflow Range (cfm)	1800-3000	2250-3750	3000-5000	3750-6250	4500-7500	6,000-10,000	7,500-12,500	9,000-15,000
Nominal Motor Hp (Standard Motor)								
208/230-1-60	1.3	2.4	—	—	—	—	—	—
208/230-3-60 and 460-3-60	2.4	2.4	2.4	2.9	3.7	5.0	7.5	10.0
575-3-60	1.0	2.0	2.0	3.0	3.0	5.0	7.5	10.0
230-3-50, 400-3-50	2.4	2.4	2.9	2.9	2.9	5.0	7.5	10.0
Motor Speed (rpm)								
208/230-1-60	1725	1725	—	—	—	—	—	—
208/230-3-60 and 460-3-60	1725	1725	1725	1725	1725	1745	1745	1745
575-3-60	1725	1725	1725	1725	1725	1745	1755	1755
230-3-50, 400-3-50	1425	1425	1425	1425	1425	1425	1425	1425
REFRIGERANT								
Operating charge (lb) (approx per circuit)*	3.0	3.0	1.5/1.5	2.0/2.0	2.5/2.5	3.5/3.5	4.5/4.5	5.0/5.0
DIRECT-EXPANSION COIL								
Max Working Pressure (psig)								
Face Area (sq ft)	6.67	8.33	10.0	13.25	17.67	19.88	24.86	29.83
No. of Splits	1	1	2	2	2	2	2	2
No. of Circuits per Split (3 Row/4 Row)	12/12	15/15	9/9	9/12	12/16	13/18	15/20	18/24
Split Type...Percentage	—	—	—	—	—	Face...50/50	—	—
Fins/in.	15	15	17	15	15	17	15	15
STEAM COIL								
Max Working Pressure (psig at 260 F)								
Total Face Area (sq ft)	6.67	6.67	6.67	13.33	13.33	13.33	15.0	15.0
Rows...Fins/in.	1...9	1...9	1...9	1...10	1...10	1...10	1...10	1...10
HOT WATER COIL								
Max Working Pressure (psig)								
Total Face Area (sq ft)	6.67	6.67	6.67	13.33	13.33	13.33	15.0	15.0
Rows...Fins/in.	2...8.5	2...8.5	2...8.5	2...8.5	2...8.5	2...8.5	2...12.5	2...12.5
Water Volume (gal)		8.3			13.9		14.3	
(ft ³)		1.1			1.85		1.90	
PIPING CONNECTIONS,								
Quantity...Size (in.)								
DX Coil — Suction (ODF)	1...1 ¹ / ₈	1...1 ¹ / ₈	2...1 ¹ / ₈	2...1 ¹ / ₈	2...1 ¹ / ₈	2...1 ¹ / ₈	2...1 ³ / ₈	2...1 ³ / ₈
DX Coil — Liquid Refrigerant (ODF)		1...5 ⁵ / ₈				2...5 ⁵ / ₈		
Steam Coil, In (MPT)		1...2 ¹ / ₂				1...2 ¹ / ₂		
Steam Coil, Out (MPT)		1...1 ¹ / ₂				1...1 ¹ / ₂		
Hot Water Coil, In (MPT)		1...1 ¹ / ₂	1...1 ¹ / ₂			1...2		
Hot Water Coil, Out (MPT)		1...1 ¹ / ₂	1...1 ¹ / ₂			1...2		
Condensate (PVC)				1...1 ¹ / ₄	ODM/1 IDF			
FILTERS								
Quantity...Size (in.)		4...16 x 24 x 2			4...16 x 20 x 2		4...20 x 24 x 2	
Access Location					4...16 x 24 x 2		4...20 x 25 x 2	
					Either Side			

LEGEND

DX — Direct Expansion
TXV — Thermostatic Expansion Valve

*Units are shipped without refrigerant charge.

Table 1B — 40RMQ Physical Data, English — Heat Pump Units

UNIT 40RMQ	008	012	016	024	028
NOMINAL CAPACITY (Tons)	7½	10	15	20	25
OPERATING WEIGHT (lb)					
Base Unit with TXV	385	427	713	720	1050
Plenum	175	175	225	140	180
FANS					
Qty...Diam. (in.)	1...15	1...15	2...15	2...15	2...18
Nominal Airflow (cfm)	3000	4000	6000	8000	10,000
Airflow Range (cfm)	2250-3750	3000-5000	4500-7500	6000-10,000	7500-12,500
Nominal Motor Hp (Standard Motor)					
208/230-1-60	2.4	—	—	—	—
208/230-3-60 and 460-3-60	2.4	2.4	3.7	5.0	7.5
575-3-60	2.0	2.0	3.0	5.0	7.5
230-3-50, 400-3-50	2.4	2.9	2.9	5.0	7.5
Motor Speed (rpm)					
208/230-1-60	1725	—	—	—	—
208/230-3-60 and 460-3-60	1725	1725	1725	1745	1745
575-3-60	1725	1725	1725	1745	1755
230-3-50, 400-3-50	1425	1425	1425	1425	1425
REFRIGERANT			R-22		
Operating charge (lb) (approx per circuit)*	3.0	2.0/2.0	3.0/3.0	3.5/3.5	4.5/4.5
DIRECT-EXPANSION COIL	Enhanced Copper Tubes, Aluminum Sine-Wave Fins				
Max Working Pressure (psig)			435		
Face Area (sq ft)	8.33	10.0	19.88	19.88	24.86
No. of Splits	1	2	2	2	2
No. of Circuits per Split	15	9	18	18	24/16
Split Type...Percentage	—	—	Face...50/50	—	Face...60/40
Rows...Fins/in.	3...15	4...15	4...15	4...15	4...15
STEAM COIL					
Max Working Pressure (psig at 260 F)			20		
Total Face Area (sq ft)	6.67	6.67	13.33	13.33	15.0
Rows...Fins/in.	1...9	1...9	1...10	1...10	1...10
HOT WATER COIL					
Max Working Pressure (psig)			150		
Total Face Area (sq ft)	6.67	6.67	13.33	13.33	15.0
Rows...Fins/in.	2...8.5	2...8.5	2...8.5	2...8.5	2...12.5
Water Volume					
(gal)		8.3		13.9	
(ft ³)		1.1		1.85	
PIPING CONNECTIONS,					
Quantity...Size (in.)					
DX Coil — Vapor (ODF)	1...1½	2...1½	2...1½	2...1½	2...1¾
DX Coil — Liquid Refrigerant (ODF)	1...5/8	2...5/8	2...5/8	2...5/8	2...5/8
Steam Coil, In (MPT)	1...2½		1...2½		1...2½
Steam Coil, Out (MPT)	1...1½		1...1½		1...1½
Hot Water Coil, In (MPT)	1...1½	1...1½		1...2	1...2
Hot Water Coil, Out (MPT)	1...1½	1...1½		1...2	1...2
Condensate (PVC)			1...1¼ ODM/1 IDF		
FILTERS			Throwaway — Factory Supplied		
Quantity...Size (in.)	4...16 x 24 x 2		4...16 x 20 x 2		4...20 x 24 x 2
Access Location		Either Side	4...16 x 24 x 2		Right or Left Side

LEGEND

- DX** — Direct Expansion
TXV — Thermostatic Expansion Valve

*Units are shipped without refrigerant charge.

Table 1C — 40RMS Physical Data, English — Chilled Water Units

UNIT 40RMS	008	010	012	014	016	024	028	034
NOMINAL CAPACITY (Tons)	7 ¹ / ₂	8 ¹ / ₂	10	12 ¹ / ₂	15	20	25	30
OPERATING WEIGHT (lb)								
Base Unit	390	391	391	661	677	683	1035	1042
Plenum	175	175	175	225	225	225	325	325
FANS								
Qty...Diam. (in.)	1...15	1...15	1...15	2...15	2...15	2...15	2...18	2...18
Nominal Airflow (cfm)	3000	3400	4000	5000	6000	8000	10,000	12,000
Airflow Range (cfm)	2250-3750	2250-4250	3000-5000	3750-6250	4500-7500	6000-10,000	7500-12,500	9000-15,000
Nominal Motor Hp (Standard Motor)								
208/230-1-60	2.4	2.4	—	—	—	—	—	—
208/230-3-60 and 460-3-60	2.4	2.4	2.4	2.9	3.7	5.0	7.5	10.0
575-3-60	2.0	2.0	2.0	3.0	3.0	5.0	7.5	10.0
230-3-50 and 400-3-50	2.4	2.4	2.9	2.9	2.9	5.0	7.5	10.0
Motor Speed (rpm)								
208/230-1-60	1725	1725	—	—	—	—	—	—
208/230-3-60 and 460-3-60	1725	1725	1725	1725	1725	1745	1745	1745
575-3-60	1725	1725	1725	1725	1725	1745	1755	1755
230-3-50 and 400-3-50	1425	1425	1425	1425	1425	1425	1425	1425
CHILLED WATER COIL	Enhanced Copper Tubes, Aluminum Sine-Wave Fins							
Max Working Pressure (psig)	435							
Face Area (sq ft) — Upper	8.3	9.0	9.9	8.3	8.3	11.0	12.4	15.5
Face Area (sq ft) — Lower	—	—	—	5.5	8.3	8.3	12.4	12.4
Rows...Fins/in.	3...15							
STEAM COIL								
Max Working Pressure (psig at 260 F)	20							
Total Face Area (sq ft)	6.67	6.67	6.67	13.33	13.33	13.33	15.0	15.0
Rows...Fins/in.	1...9	1...9	1...9	1...10	1...10	1...10	1...10	1...10
HOT WATER COIL								
Max Working Pressure (in. wg)	150							
Total Face Area (sq ft)	6.67	6.67	6.67	13.33	13.33	13.33	15.0	15.0
Rows...Fins/in.	2...8.5	2...8.5	2...8.5	2...8.5	2...8.5	2...8.5	2...12.5	2...12.5
Water Volume (gal)	8.3				13.9		14.3	
(ft ³)	1.1				1.85		1.90	
PIPING CONNECTIONS, Quantity...Size (in.)								
Chilled Water — In	1...1 ³ / ₈ ODF	1...1 ³ / ₈ ODF	2...1 ³ / ₈ ODF	2...1 ³ / ₈ ODM	2...1 ³ / ₈ ODM	2...1 ³ / ₈ ODM	2...2 ¹ / ₈ ODM	2...2 ¹ / ₈ ODM
Chilled Water — Out	1...1 ³ / ₈ ODF	1...1 ³ / ₈ ODF	2...1 ³ / ₈ ODF	2...1 ³ / ₈ ODM	2...1 ³ / ₈ ODM	2...1 ³ / ₈ ODM	2...2 ¹ / ₈ ODM	2...2 ¹ / ₈ ODM
Steam Coil, In (MPT)	1...2 ¹ / ₂				1...2 ¹ / ₂			
Steam Coil, Out (MPT)	1...1 ¹ / ₂				1...1 ¹ / ₂			
Hot Water Coil, In (MPT)	1...1 ¹ / ₂		1...1 ¹ / ₂			1...2		
Hot Water Coil, Out (MPT)	1...1 ¹ / ₂		1...1 ¹ / ₂			1...2		
Condensate (PVC)	1...1 ¹ / ₄ ODM/1 IDF							
FILTERS								
Quantity...Size (in.)	4...16 x 24 x 2				Throwaway — Factory Supplied		4...20 x 24 x 2	
Access Location					4...16 x 20 x 2		4...20 x 24 x 2	
					4...16 x 24 x 2		4...20 x 25 x 2	
					Either Side			

Table 1D — 40RM Physical Data, SI — Cooling Units

UNIT 40RM	007	008	012	014	016	024	028	034
NOMINAL CAPACITY (kW)	21	26	35	43	52	70	87	105
OPERATING WEIGHT (kg)								
Base Unit with TXV	173	175	184	304	311	313	463	467
Plenum	80	80	80	102	102	102	148	148
FANS								
Qty...Diam. (mm)	1...381	1...381	1...381	2...381	2...381	2...381	2...457	2...457
Nominal Airflow (L/s)	1133	1604	1888	2360	2831	3775	4719	5663
Airflow Range (L/s)	850-1416	1203-2006	1416-2360	1770-2949	2124-3539	2831-4719	3539-5899	4247-7079
Nominal Motor kW (Standard Motor)								
208/230-1-60	0.97	1.79	—	—	—	—	—	—
208/230-3-60 and 460-3-60	1.79	1.79	1.79	2.16	2.76	3.73	5.60	7.46
575-3-60	0.75	1.49	1.49	2.24	2.24	3.73	5.60	7.46
230-3-50, 400-3-50	1.79	1.79	2.16	2.16	2.16	3.73	5.60	7.46
Motor Speed (r/s)								
208/230-1-60	28.8	28.8	—	—	—	—	—	—
208/230-3-60 and 460-3-60	28.8	28.8	28.8	28.8	28.8	29.1	29.1	29.1
575-3-60	28.8	28.8	28.8	28.8	28.8	29.1	29.3	29.3
230-3-50, 400-3-50	23.8	23.8	23.8	23.8	23.8	23.8	23.8	23.8
REFRIGERANT	R-22							
Operating charge (kg) (approx per circuit)*	1.36	1.36	0.68/0.68	0.90/0.90	1.13/1.13	1.59/1.59	2.04/2.04	2.27/2.27
DIRECT-EXPANSION COIL	Enhanced Copper Tubes, Aluminum Sine-Wave Fins							
Max Working Pressure (kPag)	2999							
Face Area (sq m)	0.62	0.77	0.93	0.93	1.64	1.85	2.30	2.77
No. of Splits	1	1	2	2	2	2	2	2
No. of Circuits per Split (3 Row/4 Row)	12/12	15/15	9/9	9/12	12/16	13/18	15/20	18/24
Split Type...Percentage	Face...50/50							
Fins/m	591	591	670	591	591	670	591	591
STEAM COIL	138							
Max Working Pressure (kPag at 126 C)	138							
Total Face Area (sq m)	0.62	0.62	0.62	1.24	1.24	1.24	1.39	1.39
Rows...Fins/m	1...355	1...355	1...355	1...394	1...394	1...394	1...394	1...394
HOT WATER COIL	1034							
Max Working Pressure (kPag)	1034							
Total Face Area (sq m)	0.62	0.62	0.62	1.24	1.24	1.24	1.39	1.39
Rows...Fins/m	2...335	2...335	2...335	2...335	2...335	2...335	2...493	2...493
Water Volume (L) (m ³)	31.4 0.031				52.6 0.052		54.1 0.054	
PIPING CONNECTIONS,								
Quantity...Size (in.)								
DX Coil — Suction (ODF)	1...1 ¹ / ₈	1...1 ¹ / ₈	2...1 ¹ / ₈	2...1 ¹ / ₈	2...1 ¹ / ₈	2...1 ¹ / ₈	2...1 ³ / ₈	2...1 ³ / ₈
DX Coil — Liquid Refrigerant (ODF)	1...5 ⁵ / ₈				2...5 ⁵ / ₈			
Steam Coil, In (MPT)	1...2 ¹ / ₂				1...2 ¹ / ₂			
Steam Coil, Out (MPT)	1...1 ¹ / ₂				1...1 ¹ / ₂			
Hot Water Coil, In (MPT)	1...1 ¹ / ₂		1...1 ¹ / ₂			1...2		
Hot Water Coil, Out (MPT)	1...1 ¹ / ₂		1...1 ¹ / ₂			1...2		
Condensate (PVC)	1...1 ¹ / ₄ ODM/1 IDF							
FILTERS	Throwaway — Factory Supplied							
Quantity...Size	4...406 x 610 x 51						4...508 x 610 x 51	
Access Location			Either Side				4...508 x 635 x 51	

LEGEND

- DX** — Direct Expansion
- TXV** — Thermostatic Expansion Valve

*Units are shipped without refrigerant charge.

Table 1E — 40RMQ Physical Data, SI — Heat Pump Units

UNIT 40RMQ	008	012	016	024	028
NOMINAL CAPACITY (kW)	26	35	52	70	87
OPERATING WEIGHT (kg)					
Base Unit with TXV	175	194	323	326	477
Plenum	80	80	102	44	44
FANS					
Qty...Diam. (mm)	1...381	1...381	2...381	2...381	2...457
Nominal Airflow (L/s)	1604	1888	2831	3775	4719
Airflow Range (L/s)	1203-2006	1416-2360	2124-3539	2831-4719	3539-5899
Nominal Motor kW (Standard Motor)					
208/230-1-60	1.79	—	—	—	—
208/230-3-60 and 460-3-60	1.79	1.79	2.76	3.73	5.60
575-3-60	1.49	1.49	2.24	3.73	5.60
230-3-50, 400-3-50	1.79	2.16	2.16	3.73	5.60
Motor Speed (r/s)					
208/230-1-60	28.8	—	—	—	—
208/230-3-60 and 460-3-60	28.8	28.8	28.8	29.1	29.1
575-3-60	28.8	28.8	28.8	29.1	29.3
230-3-50, 400-3-50	23.8	23.8	23.8	23.8	23.8
REFRIGERANT			R-22		
Operating charge (kg)	1.36	0.91/0.91	1.36/1.36	1.59/1.59	2.04/2.04
(approx per circuit)*					
DIRECT-EXPANSION COIL	Enhanced Copper Tubes, Aluminum Sine-Wave Fins				
Max Working Pressure (kPag)			2999		
Face Area (sq m)	0.77	0.93	1.85	1.85	2.30
No. of Splits	1	2	2	2	2
No. of Circuits per Split	15	9	18	18	24/16
Split Type...Percentage	—	—	Face...50/50	—	Face...60/40
Rows...Fins/m	3...591	4...591	4...591	4...591	4...591
STEAM COIL					
Max Working Pressure (kPag at 126 C)			138		
Total Face Area (sq m)	0.62	0.62	1.24	1.24	1.39
Rows...Fins/m	1...355	1...355	1...394	1...394	1...394
HOT WATER COIL					
Max Working Pressure (kPag)			1034		
Total Face Area (sq m)	0.62	0.62	1.24	1.24	1.39
Rows...Fins/m	2...335	2...335	2...335	2...335	2...493
Water Volume					
(L)		31.4		52.6	
(m ³)		0.031		0.052	
PIPING CONNECTIONS,					
Quantity...Size (in.)					
DX Coil — Vapor (ODF)	1...1 ¹ / ₈	2...1 ¹ / ₈		2...1 ¹ / ₈	2...1 ³ / ₈
DX Coil — Liquid Refrigerant (ODF)	1...5 ⁵ / ₈	2...5 ⁵ / ₈		2...5 ⁵ / ₈	
Steam Coil, In (MPT)	1...2 ¹ / ₂	1...2 ¹ / ₂		1...2 ¹ / ₂	
Steam Coil, Out (MPT)	1...1 ¹ / ₂	1...1 ¹ / ₂		1...1 ¹ / ₂	
Hot Water Coil, In (MPT)	1...1 ¹ / ₂	1...1 ¹ / ₂		1...2	
Hot Water Coil, Out (MPT)	1...1 ¹ / ₂	1...1 ¹ / ₂		1...2	
Condensate (Male PVC)			1...1 ¹ / ₄ ODM/1 IDF		
FILTERS	Throwaway — Factory Supplied				
Quantity...Size	4...406 x 610 x 51		4...406 x 508 x 51 4...406 x 610 x 51	4...406 x 610 x 51 4...406 x 508 x 51	4...406 x 610 x 51 4...508 x 635 x 51
Access Location		Either Side			Right or Left Side

LEGEND

- DX** — Direct Expansion
- TXV** — Thermostatic Expansion Valve

*Units are shipped without refrigerant charge.

Table 1F — 40RMS Physical Data, SI — Chilled Water Units

UNIT 40RMS	008	010	012	014	016	024	028	034
NOMINAL CAPACITY (kW)	26	29	35	43	52	70	87	105
OPERATING WEIGHT (kg)								
Base Unit	177	177	177	300	307	310	469	473
Plenum	80	80	80	102	102	102	148	148
FANS								
Qty...Diam. (mm)	1...381	1...381	1...381	2...381	2...381	2...381	2...457	2...457
Nominal Airflow (L/s)	1416	1605	1888	2360	2831	3775	4719	5663
Airflow Range (L/s)	1062-1770	1204-2006	1416-2360	1770-2949	2124-3539	2831-4719	3539-5899	4247-7079
Nominal Motor kW (Standard Motor)								
208/230-1-60	1.79	1.79	—	—	—	—	—	—
208/230-3-60, 460-3-60	1.79	1.79	1.79	1.79	2.76	3.73	5.60	7.46
575-3-60	1.49	1.49	1.49	1.49	2.24	3.73	5.60	7.46
230-3-50, 400-3-50	1.79	1.79	2.16	2.16	2.16	3.73	5.60	7.46
Motor Speed (r/s)								
208/230-1-60	28.8	28.8	—	—	—	—	—	—
208/230-3-60, 460-3-60	28.8	28.8	28.8	28.8	28.8	29.1	29.1	29.1
575-3-60	28.8	28.8	28.8	28.8	28.8	29.1	29.3	29.3
230-3-50, 400-3-50	23.8	23.8	23.8	23.8	23.8	23.8	23.8	23.8
CHILLED WATER COIL	Enhanced Copper Tubes, Aluminum Sine-Waves							
Max Working Pressure (kPag)	2999							
Face Area (sq m) — Upper	0.77	0.84	0.91	0.77	0.77	1.02	1.15	1.44
Face Area (sq m) — Lower	—	—	—	0.51	0.77	0.77	1.15	1.15
Rows...Fins/m	3...591	3...591	3...591	3...591	3...591	3...591	3...591	3...591
STEAM COIL								
Max Working Pressure (kPag at 126 C)	138							
Total Face Area (sq m)	0.62	0.62	0.62	1.24	1.24	1.24	1.39	1.39
Rows...Fins/m	1...355	1...355	1...355	1...355	1...394	1...394	1...394	1...394
HOT WATER COIL								
Max Working Pressure (kPag)	1034							
Total Face Area (sq m)	0.62	0.62	0.62	1.24	1.24	1.24	1.39	1.39
Rows...Fins/m	2...335	2...335	2...335	2...335	2...335	2...335	2...493	2...493
Water Volume								
(L)		31.4			52.6		54.1	
(m ³)		0.031			0.052		0.054	
PIPING CONNECTIONS, Quantity...Size (in.)								
Chilled Water — In	1...1 ³ / ₈ ODF	1...1 ³ / ₈ ODF	2...1 ³ / ₈ ODF	2...1 ³ / ₈ ODM	2...1 ³ / ₈ ODM	2...1 ³ / ₈ ODM	2...2 ¹ / ₈ ODM	2...2 ¹ / ₈ ODM
Chilled Water — Out	1...1 ³ / ₈ ODF	1...1 ³ / ₈ ODF	2...1 ³ / ₈ ODF	2...1 ³ / ₈ ODM	2...1 ³ / ₈ ODM	2...1 ³ / ₈ ODM	2...2 ¹ / ₈ ODM	2...2 ¹ / ₈ ODM
Steam Coil, In (MPT)	1...2 ¹ / ₂		1...2 ¹ / ₂					
Steam Coil, Out (MPT)	1...1 ¹ / ₂		1...1 ¹ / ₂					
Hot Water Coil, In (MPT)	1...1 ¹ / ₂		1...1 ¹ / ₂	1...2				
Hot Water Coil, Out (MPT)	1...1 ¹ / ₂		1...1 ¹ / ₂	1...2				
Condensate (PVC)	1...1 ¹ / ₄ ODM/1 IDF							
FILTERS	Throwaway — Factory Supplied							
Quantity...Size (mm)	4...406 x 610 x 51				4...406 x 508 x 51		4...508 x 610 x 51	
Access Location					4...406 x 610 x 51		4...508 x 635 x 51	
					Either Side			

LEGEND

TXV — Thermostatic Expansion Valve

NOTES:

1. Dimensions in [] are in millimeters.
2.  Direction of airflow.
3. Recommended clearance:
 - Rear: 3 in. (76 mm)
 - Front: 2 ft, 6 in. (762 mm)
 - Right Side: 2 ft, 6 in. (762 mm)
 - Left Side: 2 ft, 6 in. (762 mm)
 - Local codes or jurisdiction may prevail.
4. Liquid piping not supplied by Carrier.
5. Duct flange is factory supplied and field installed.
6. 40RMS units may require alternate or additional field-fabricated piping access holes.

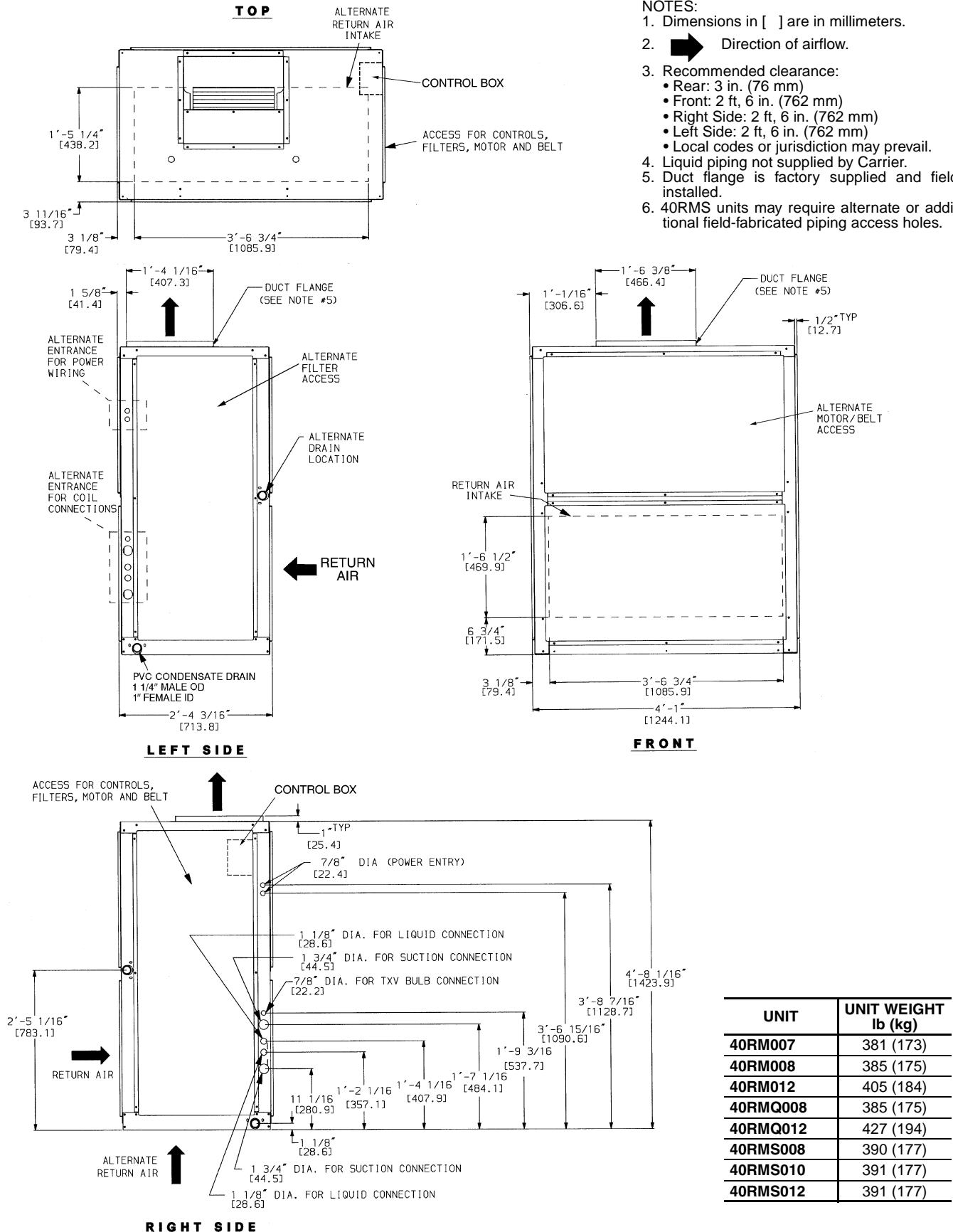

UNIT	UNIT WEIGHT lb (kg)
40RM007	381 (173)
40RM008	385 (175)
40RM012	405 (184)
40RMQ008	385 (175)
40RMQ012	427 (194)
40RMS008	390 (177)
40RMS010	391 (177)
40RMS012	391 (177)

Fig. 1A — Dimensions — Sizes 007-012

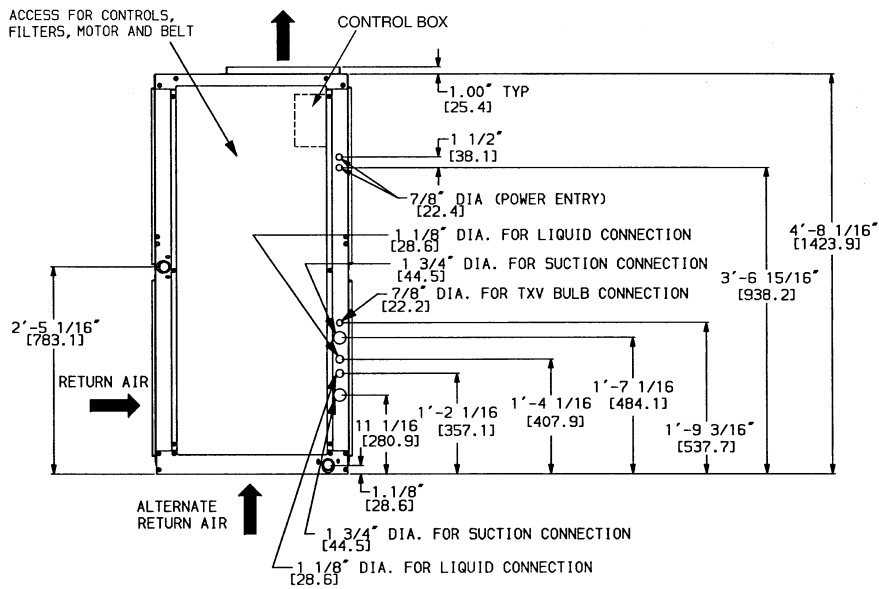
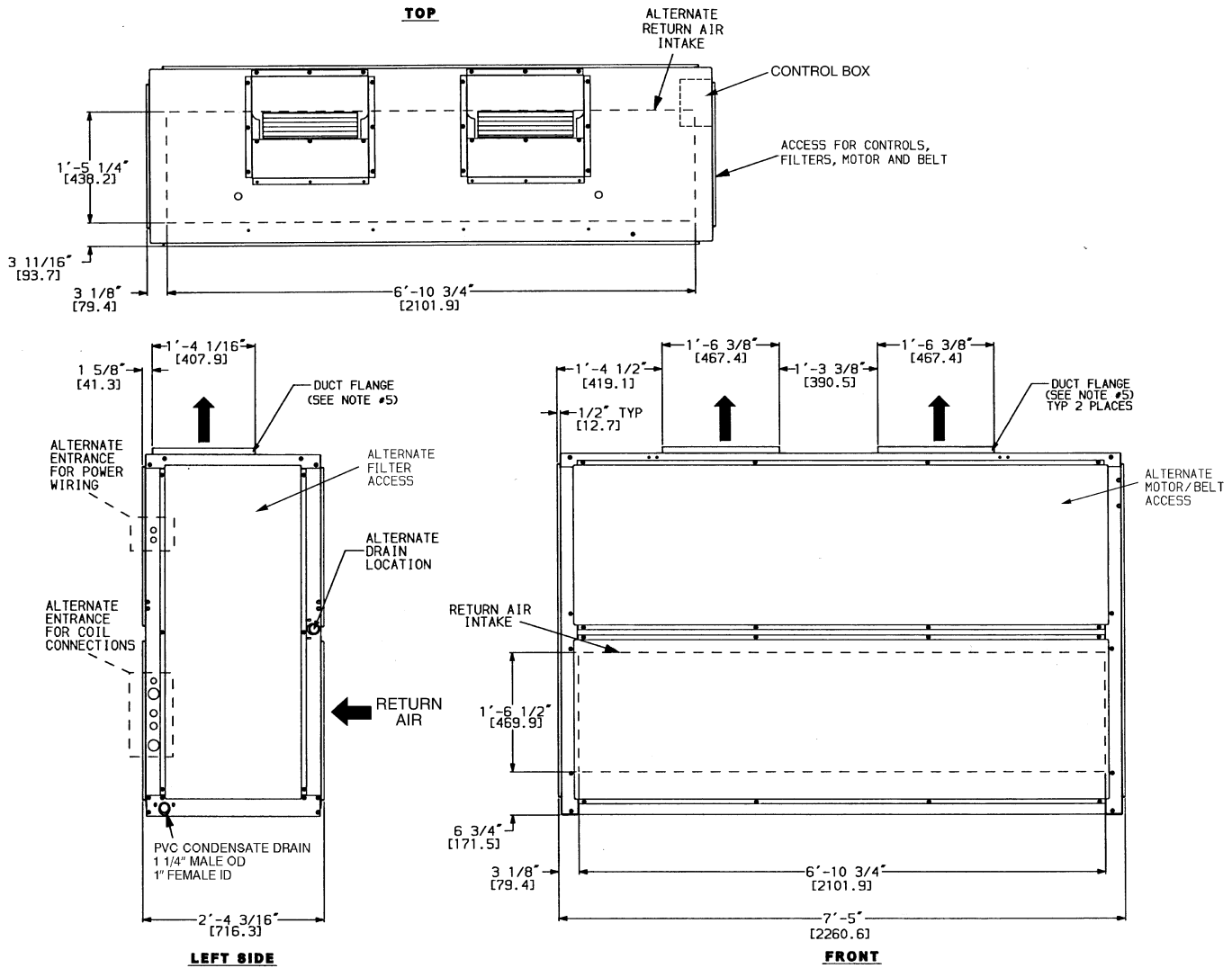

LEGEND

TXV — Thermostatic Expansion Valve

NOTES:

- Dimensions in [] are in millimeters.
- Direction of airflow.
- Recommended clearance:
 - Rear: 3 in. (76 mm)
 - Front: 2 ft, 6 in. (762 mm)
 - Right Side: 2 ft, 6 in. (762 mm)
 - Left Side: 2 ft, 6 in. (762 mm)
 - Local codes or jurisdiction may prevail.
- Liquid piping not supplied by Carrier.
- Duct flange is factory-supplied and field-installed.
- 40RMQ016,024 and 40RMS units may require alternate or additional field-fabricated piping access holes.

UNIT	UNIT WEIGHT lb (kg)
40RM014	670 (304)
40RM016	685 (311)
40RM024	690 (313)
40RMQ016	713 (323)
40RMQ024	720 (326)
40RMS014	661 (300)
40RMS016	677 (307)
40RMS024	683 (310)

Fig. 1B — Dimensions — Sizes 014-024

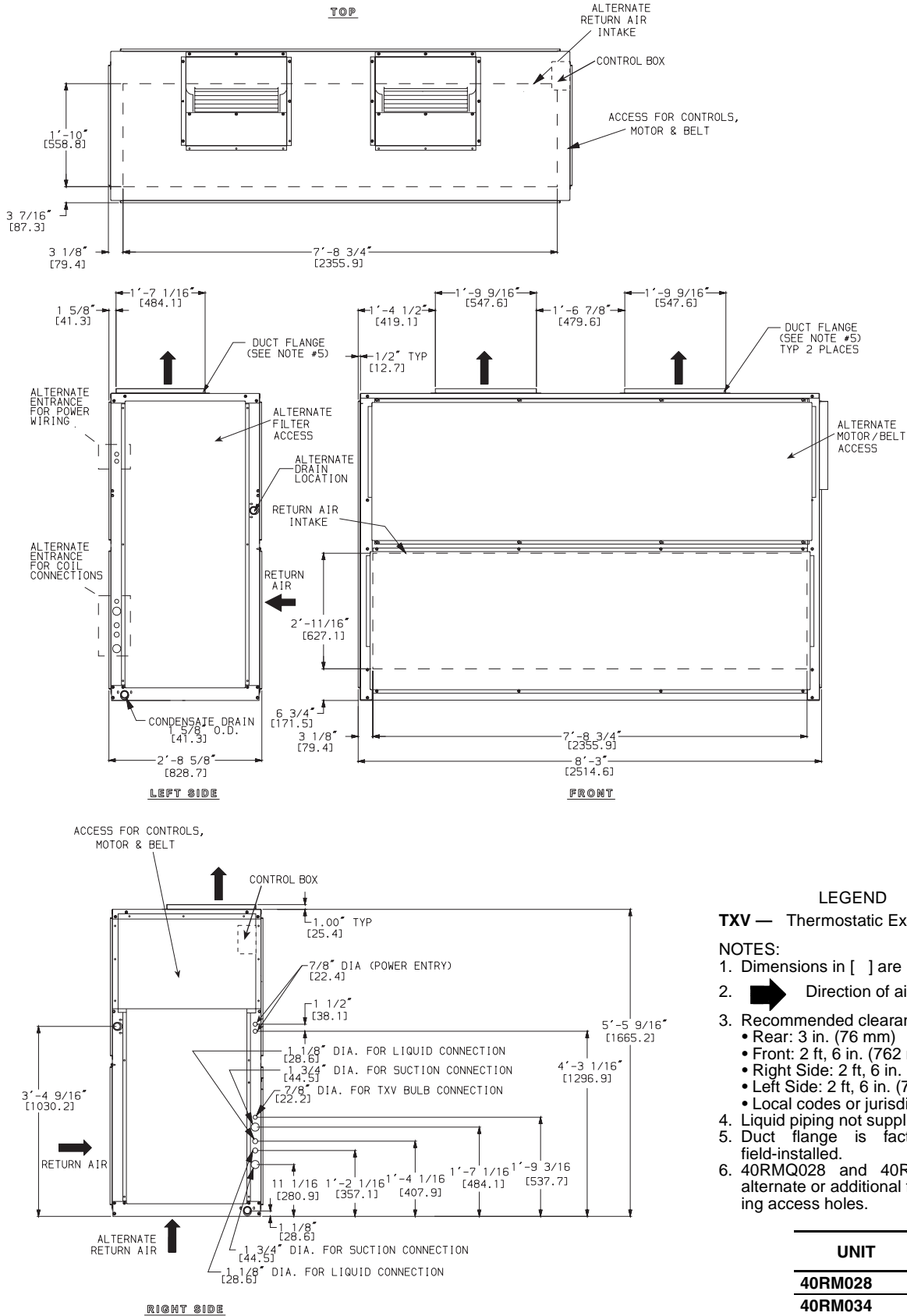

LEGEND

TXV — Thermostatic Expansion Valve

NOTES:

- Dimensions in [] are in millimeters.
- Direction of airflow.
- Recommended clearance:
 - Rear: 3 in. (76 mm)
 - Front: 2 ft, 6 in. (762 mm)
 - Right Side: 2 ft, 6 in. (762 mm)
 - Left Side: 2 ft, 6 in. (762 mm)
 - Local codes or jurisdiction may prevail.
- Liquid piping not supplied by Carrier.
- Duct flange is factory-supplied and field-installed.
- 40RMQ028 and 40RMS may require alternate or additional field fabricated piping access holes.

UNIT	UNIT WEIGHT lb (kg)
40RM028	1020 (463)
40RM034	1030 (467)
40RMQ028	1050 (477)
40RMS028	1035 (469)
40RMS034	1042 (473)

Fig. 1C — Dimensions — Sizes 028,034

Unit Positioning — The unit can be mounted on the floor for vertical application with return air entering the face of the unit and supply air discharging vertically through the top of the unit. The unit can also be applied in a horizontal arrangement with return air entering horizontally and the supply air discharging horizontally. When applying the unit in a horizontal arrangement, ensure the condensate drain pan is located at the bottom center of the unit for adequate condensate disposal. See Fig. 4 for condensate connections for each unit position.

Typical positioning and alternate return air locations are shown in Fig. 4. Alternate return air locations can be used by moving the unit panel from the alternate return air location to the standard return air location. Refer to overhead suspension accessory drawing (Fig. 5) for preferred suspension technique. The unit needs support underneath to prevent sagging.

IMPORTANT: Do NOT attempt to install unit with return air entering top panel of unit. Condensate will not drain from unit.

Unit Isolation — Where extremely quiet operation is essential, install isolators between floor and base of unit, or between ceiling and top section of unit.

Be sure that unit is level and adequately supported. Use channels at front and sides of unit for reference points when leveling.

Refrigerant and Chilled Water Piping Access

— The 40RM Series units come with standard knockouts for refrigerant and chilled water piping. These knockouts are located on both sides of the unit for installation flexibility. The standard knockouts provide sufficient access to the unit's coils for all 40RM and some 40RMQ units, however, for 40RMQ016,028 and 40RMS units, additional holes must be field-fabricated to accommodate the piping. See Fig. 6 for the positions and dimensions of the additional access holes required for these units, including hole diameters and drilling dimensions. Recommended access hole use is also listed for all units. Note that Fig. 6 shows the access holes on the control-box side of the unit; this is the side of the unit with the coil headers, so it is used most often for piping access.

IMPORTANT: Do not bury refrigerant piping underground.

Refrigerant Piping — See Tables 1A, 1B, 1D, 1E for refrigerant pipe connection sizes. For ease in brazing, it is recommended that all internal solder joints be made before unit is placed in final position.

The 40RM and 40RMQ direct-expansion units have internal factory-installed thermostatic expansion valves (TXVs), distributors, and nozzles for use with R-22. See Table 2 for part numbers. Knockouts are provided in the unit corner posts for 40RM and 40RMQ008 and 012 refrigerant piping. The 40RMQ016,024 and 028 units requires additional field-fabricated piping access holes. See Fig. 6, which also lists recommended knockouts and access holes to use for each 40RM and 40RMQ unit size. Recommended fittings are listed in Table 3.

The sensor bulb capillary tubes must be routed from the TXVs inside the unit through one of the piping access holes. Clamp the TXV sensor bulb on a vertical portion of the suction line, outside the unit. See Fig. 7.

NOTE: Be sure to remove the styrofoam shipping pad from the TXV. Verify that it has been removed. See Fig. 3.

IMPORTANT: Never attach the sensor to the suction manifold. Do NOT mount the sensor on a trapped portion of the suction line.

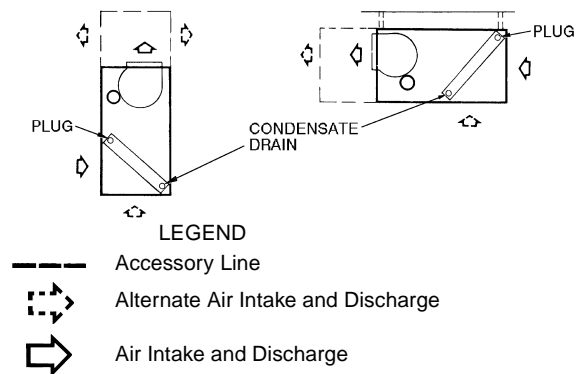

Fig. 4 — Typical Unit Positioning

The 40RM Series evaporator coils have a face-split design. Ensure that lower circuit of coil is first on/last off when connected to the condensing unit and/or system controls. See Fig. 8.

External TXV equalizer connections are provided and factory-brazed into the coil suction manifolds.

If suction line must be horizontal, clamp bulb to suction line at least 45 degrees above bottom, at approximately the 4 o'clock or 8 o'clock position. See Fig. 9.

NOTE: The 40RMQ units are supplied with factory-installed thermostatic expansion valves and check valve bypasses. No extra piping connections or kits are required to install the 40RMQ with a 38AQ, 38ARQ, or 38AQS condensing unit in a heat pump system, however, some field-supplied components may be required. See the following two sections.

HEAT PUMP SYSTEM PIPING — Addition of a liquid solenoid valve (LLSV) is recommended. The LLSV must be a bi-flow type suited for use in heat pump systems. Refer to the 38AQ, ARQ, AQS literature for recommended component part numbers. Wire the solenoid valve in parallel with the compressor contactor coil.

The LLSV must be installed at the outdoor unit with the flow arrow pointed toward the outdoor unit (in-flow direction for the heating mode.)

38ARQ DUPLEX/40RMQ024 HEAT PUMP SYSTEM PIPING — Two 38ARQ012 heat pump condensing units may be connected in a duplex arrangement with the 40RMQ024. See Fig. 10. Ensure that the lower circuit of the 40RMQ coil is the first on/last off by connecting to the "A" condensing unit and by configuring the controls so that the "A" condensing unit is the first on/last off.

38ARQ012/38AQS016 DUPLEX/40RMQ028 HEAT PUMP SYSTEM PIPING — One 38ARQ012 and one 38AQS016 heat pump condensing unit may be connected in a duplex arrangement with the 40RMQ028. See Fig. 10. The 40RMQ028 has a 60/40 face split coil. Ensure that the larger coil section (connection "B", Fig. 8) is connected to the 38AQS016 and the smaller coil section is connected to the 38ARQ012. In addition, ensure that the lower circuit of the 40RMQ coil is the first on/last off by connecting to the "A" condensing unit and by configuring (see 38ARQ,AQS installation instructions for more information) the controls so that the "A" condensing unit is the first on/last off.

FILTER DRIER REQUIREMENTS FOR HEAT PUMP SYSTEMS — The 38ARQ and 38AQS units do not include filter driers. Filter driers must be field-supplied and field-installed. The filter driers used with these systems must be bi-flow types suited for use in heat pump applications. Refer to the 38AQ,ARQ,AQS literature for recommended component part numbers. See Fig. 11 for filter drier quantity and location information.

OVERHEAD SUSPENSION ACCESSORY

UNIT SIZES 007-012

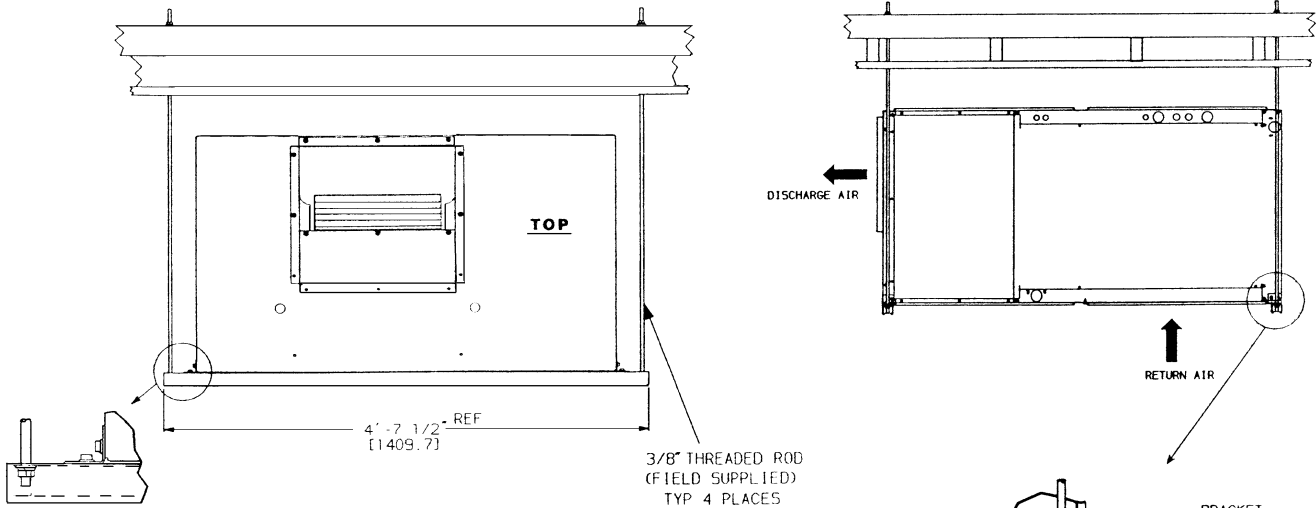

UNIT SIZES 014-024

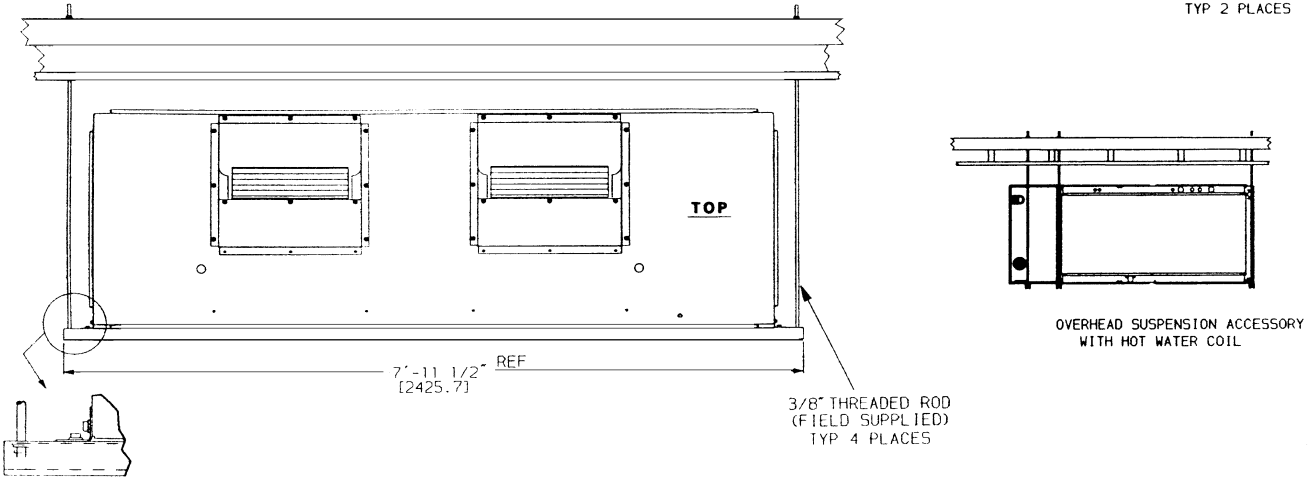

UNIT SIZES 028,034

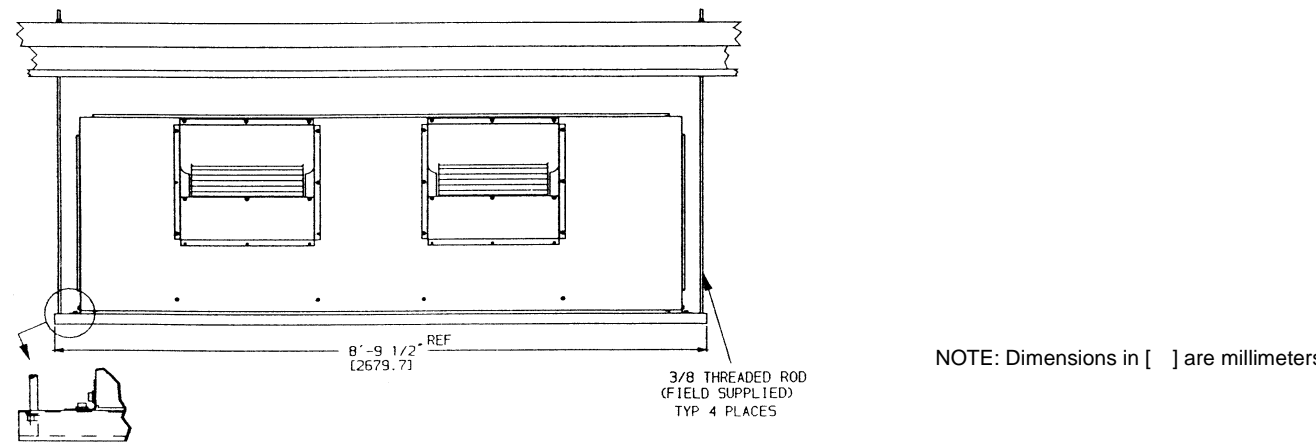

NOTE: Dimensions in [] are millimeters.

Fig. 5 — Preferred Suspension Technique

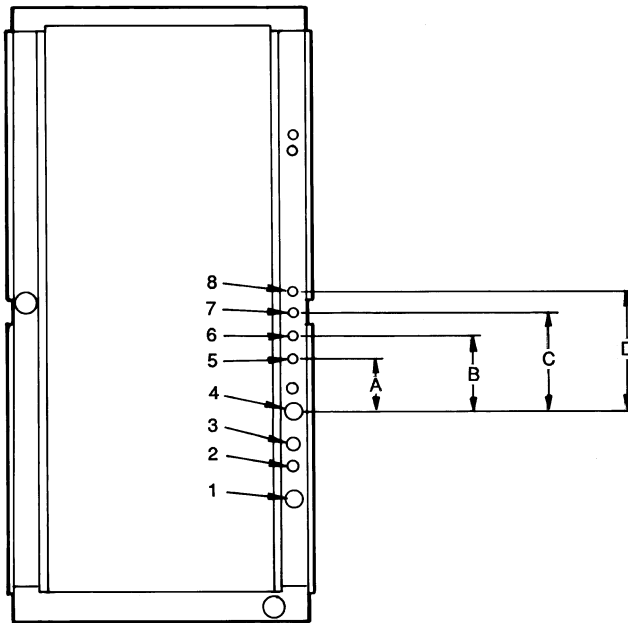

UNIT	USE HOLE NUMBERS	FIELD-FABRICATED HOLE DIAMETERS, in. (mm)				FIELD-FABRICATED HOLE POSITION DIMENSIONS, in. (mm)			
		No. 5	No. 6	No. 7	No. 8	A	B	C	D
40RM007,008 40RMQ008	1, 3	—	—	—	—	—	—	—	—
40RM012-034 40RMQ012	1, 2, 3, 4	—	—	—	—	—	—	—	—
40RMS008-012	4, 5	1 ³ / ₄ (44.5)	—	—	—	6.25 (158.8)	—	—	—
40RMS014-024	4, 5, 6, 7	1 ³ / ₄ (44.5)	1 ³ / ₄ (44.5)	1 ³ / ₄ (44.5)	—	3.0 (76.2)	6.0 (152.4)	10.5 (266.7)	—
40RMQ016,024,028	3*, 5, 6, 7	1 ¹ / ₈ (28.6)	1 ¹ / ₈ (28.6)	1 ³ / ₄ (44.5)	—	3.25 (82.6)	6.125 (155.6)	10.38 (263.7)	—
40RMS028,034	5, 6, 7, 8	2 ¹ / ₂ (63.5)	2 ¹ / ₂ (63.5)	2 ¹ / ₂ (63.5)	2 ¹ / ₂ (63.5)	6.0 (152.4)	9.625 (244.5)	13.38 (339.9)	17.0 (431.8)

*Must be enlarged from 1¹/₈ in. to 1³/₄ inches.
 NOTE: Access hole knockouts 1-4 are factory-supplied.

Fig. 6 — Refrigerant and Chilled Water Piping Access Holes

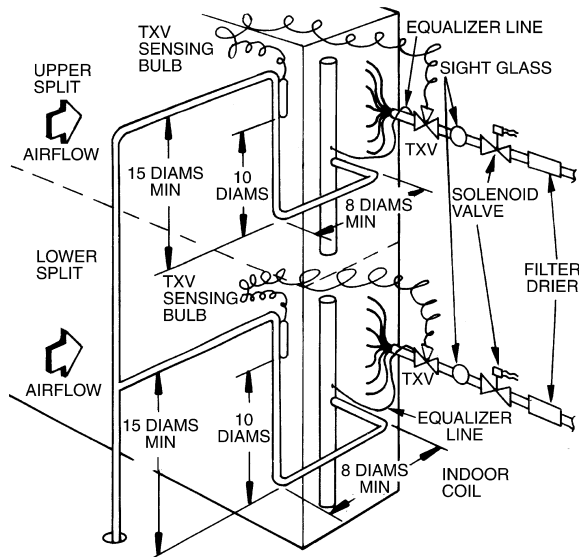

LEGEND
 TXV — Thermostatic Expansion Valve
 NOTE: Component location arrangement shown for field installation of sight glasses, solenoid valves, filter driers, and TXV sensing bulbs. The TXVs and equalizer lines are factory installed.

Fig. 7 — Face-Split Coil Suction and Liquid Line Piping (Typical)

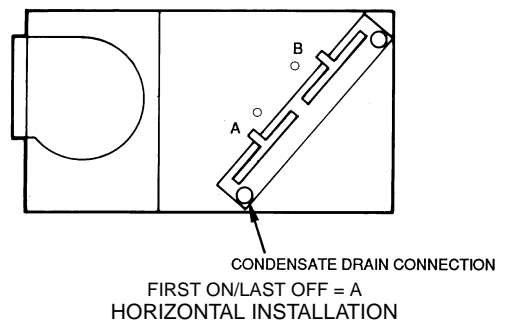
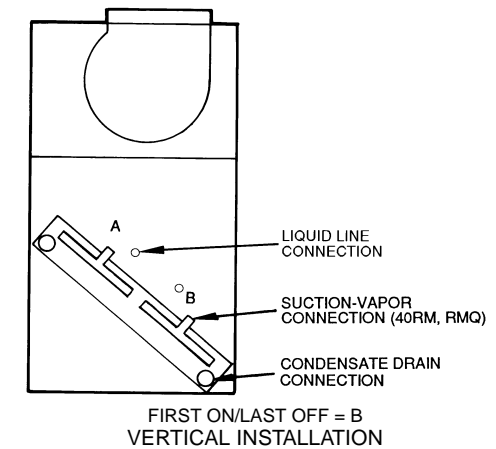
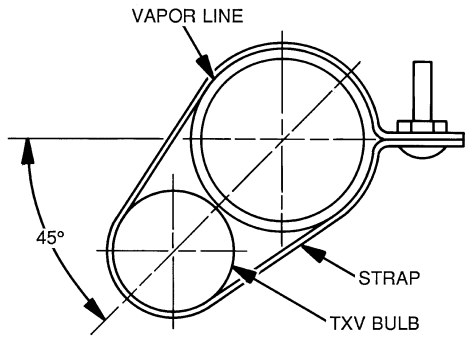

Fig. 8 — Typical Evaporator Coil Connections (40RM, 40RMQ)



LEGEND

TXV — Thermostatic Expansion Valve

NOTE: The 8 o'clock position is shown above.

Fig. 9 — TXV Sensing Bulb Location

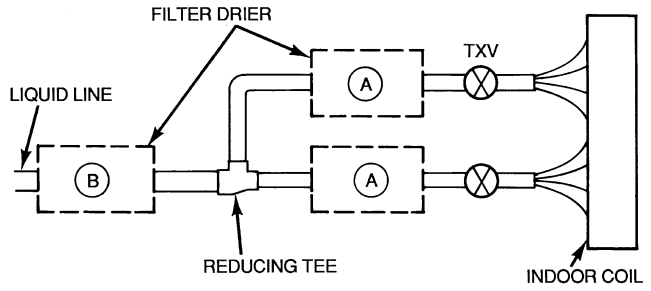

UNIT	QUANTITY REQUIRED	FIGURE REFERENCE
38ARQ008,012	1	B
38AQS016	2	A
38ARQ012 (2)	2	A
38ARQ012, AQS016	2	A

LEGEND

TXV — Thermostatic Expansion Valve

Fig. 11 — Filter Drier Quantity and Location

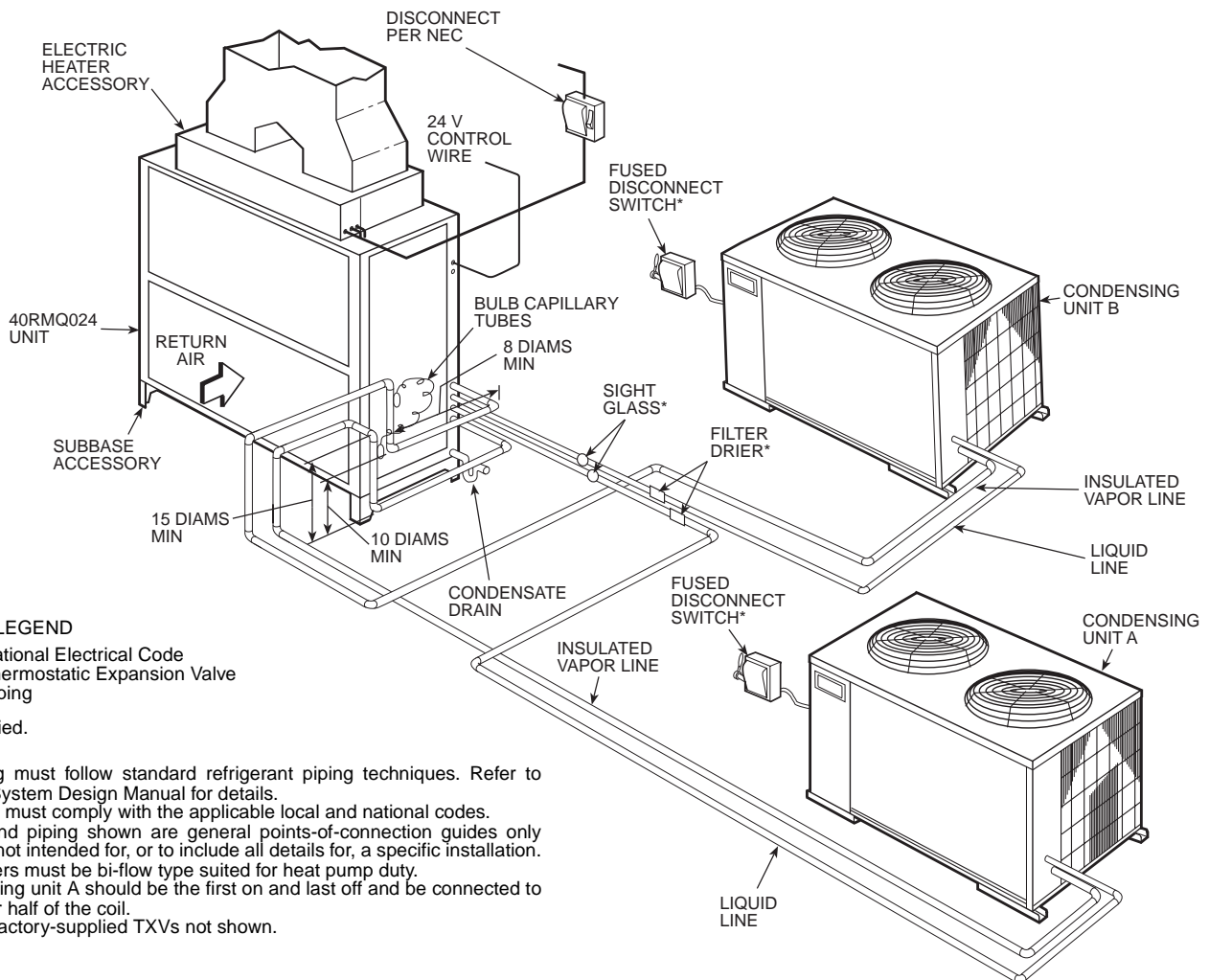

LEGEND

NEC — National Electrical Code

TXV — Thermostatic Expansion Valve

— Piping

*Field supplied.

NOTES:

1. All piping must follow standard refrigerant piping techniques. Refer to Carrier System Design Manual for details.
2. All wiring must comply with the applicable local and national codes.
3. Wiring and piping shown are general points-of-connection guides only and are not intended for, or to include all details for, a specific installation.
4. Filter driers must be bi-flow type suited for heat pump duty.
5. Condensing unit A should be the first on and last off and be connected to the lower half of the coil.
6. Internal factory-supplied TXVs not shown.

Fig. 10 — Typical Installation — 40RMQ024,028

Table 2 — Factory-Installed Nozzle and Distributor Data

UNIT	COIL TYPE	TXV Qty...Part No.	DISTRIBUTOR Qty...Part No.	FEEDER TUBES PER DISTRIBUTOR* Qty...Size (in.)	NOZZLE Qty...Part No.
40RM007	3, 4 Row	1...TDEBX8	1...1116	12... ¹ / ₄	1...E5
40RM008	3, 4 Row	1...TDEBX8	1...1126	15... ¹ / ₄	1...C6
40RMQ008	—	1...TDEBX8	1...1657	15... ¹ / ₄	1...C6
40RM012	3, 4 Row	2...TDEX6	2...1115	9... ¹ / ₄	2...E4
40RMQ012	—	2...TDEX4	2...1655	9... ¹ / ₄	2...E4
40RM014	3 Row 4 Row	2...TDEBX8 2...TDEBX8	2...1115	9... ¹ / ₄ 6... ¹ / ₄	2...E5
40RM016	3 Row 4 Row	2...TDEBX8 2...TDEBX8	2...1116 2...1126	12... ¹ / ₄ 16... ¹ / ₄	2...E6 2...C6
40RMQ016	—	2...TDEBX8	2...1657	16... ¹ / ₄	2...C6
40RM024	3 Row 4 Row	2...TDEBX11 2...TDEBX11	2...1116 2...1126	13... ¹ / ₄ 18... ³ / ₁₆	2...E8 2...C8
40RMQ024	—	2...TDEBX11	2...1655	18... ³ / ₁₆	2...E8
40RM028	3 Row 4 Row	2...TDEBX11 2...TDEBX11	2...1126 2...1126	15... ¹ / ₄ 20... ³ / ₁₆	2...C10 2...C15
40RMQ028	—	2...TDEBX11	2...1655	20... ³ / ₁₆	2...E15
40RM034	3 Row 4 Row	2...TDEBX16 2...TDEBX16	2...1126 2...1126	18... ¹ / ₄ 24... ³ / ₁₆	2...C12 2...C17

*Feeder tube size is ¹/₄ in. (6.35 mm).

NOTE: Hot gas bypass applications require field-supplied auxiliary side connector.

Table 3 — Fitting Requirements

UNIT	ACCESS HOLE NO.*	CONNECTION TYPE	CIRCUIT	FITTINGS REQUIRED† (in.)
40RM 007	1	Suction	—	1 ¹ / ₈ Street Elbow 1 ¹ / ₈ Nipple, 10 ⁵ / ₈ L 1 ¹ / ₈ Long Radius Elbow
	3	Liquid	—	5 ⁵ / ₈ Street Elbow 5 ⁵ / ₈ Nipple, 8 ⁵ / ₈ L 5 ⁵ / ₈ Long Radius Elbow
40RM 40RMQ 008	1	Suction	—	1 ¹ / ₈ Street Elbow 1 ¹ / ₈ Nipple, 8 ⁵ / ₈ L 1 ¹ / ₈ Long Radius Elbow
	3	Liquid	—	5 ⁵ / ₈ Street Elbow 5 ⁵ / ₈ Nipple, 8 ⁵ / ₈ L 5 ⁵ / ₈ Long Radius Elbow
40RMS 008-012	4	Return	—	1 ³ / ₈ Nipple, 4 ³ / ₈ L 1 ³ / ₈ Long Radius Elbow 1 ³ / ₈ Nipple, 7 ³ / ₈ L 1 ³ / ₈ Long Radius Elbow
	5	Supply	—	1 ³ / ₈ Nipple, 6 ⁵ / ₈ L 1 ³ / ₈ Long Radius Elbow
40RM 012	1	Suction	Lower	(2) 1 ¹ / ₈ Street Elbow
	2	Liquid	Lower	5 ⁵ / ₈ Street Elbow 5 ⁵ / ₈ Nipple, 8 ¹ / ₂ L 5 ⁵ / ₈ Long Radius Elbow
	3	Liquid	Upper	5 ⁵ / ₈ Street Elbow 5 ⁵ / ₈ Nipple, 13 ¹ / ₂ L 5 ⁵ / ₈ Long Radius Elbow
	4	Suction	Upper	1 ¹ / ₈ Nipple, 5 ³ / ₄ L 1 ¹ / ₈ Long Radius Elbow 1 ¹ / ₈ Nipple, 12 L 1 ¹ / ₈ Long Radius Elbow
40RMQ 012	1	Suction	Lower	(2) 1 ¹ / ₈ Street Elbow
	2	Liquid	Lower	5 ⁵ / ₈ Street Elbow 5 ⁵ / ₈ Nipple, 5 ¹ / ₂ L 5 ⁵ / ₈ Long Radius Elbow
	3	Liquid	Upper	5 ⁵ / ₈ Street Elbow 5 ⁵ / ₈ Nipple, 10 ¹ / ₂ L 5 ⁵ / ₈ Long Radius Elbow
	4	Suction	Upper	1 ¹ / ₈ Nipple, 5 ⁵ / ₈ L 1 ¹ / ₈ Long Radius Elbow 1 ¹ / ₈ Nipple, 12 L 1 ¹ / ₈ Long Radius Elbow

*See Fig. 6 for access hole location by number.

†Fittings are listed in order from header or tee stub connection out to access hole in corner support post.

Table 3 — Fitting Requirements (cont)

UNIT	ACCESS HOLE NO.*	CONNECTION TYPE	CIRCUIT	FITTINGS REQUIRED† (in.)
40RM 014	1	Suction	Lower	1 ¹ / ₈ Street Elbow 1 ¹ / ₈ Nipple, 7 ⁵ / ₈ L 1 ¹ / ₈ Long Radius Elbow
	2	Liquid	Lower	5 ⁵ / ₈ Street Elbow 5 ⁵ / ₈ Nipple, 17 ¹ / ₁₆ L 5 ⁵ / ₈ Long Radius Elbow
	3	Liquid	Upper	5 ⁵ / ₈ Street Elbow 5 ⁵ / ₈ Nipple, 11 ¹ / ₂ L 5 ⁵ / ₈ Long Radius Elbow
	4	Suction	Upper	1 ¹ / ₈ Nipple, 5 ⁵ / ₈ L 1 ¹ / ₈ Long Radius Elbow 1 ¹ / ₈ Nipple, 13 L 1 ¹ / ₈ Long Radius Elbow
40RMS 014-024	4	Supply	Lower	1 ³ / ₈ Long Radius Elbow 1 ³ / ₈ Nipple, 3 ³ / ₄ L 1 ³ / ₈ Long Radius Elbow
	5	Return	Lower	1 ³ / ₈ Long Radius Elbow 1 ³ / ₈ Nipple, 3 ³ / ₈ L 1 ³ / ₈ Long Radius Elbow
	6	Return	Upper	1 ³ / ₈ Long Radius Elbow 1 ³ / ₈ Nipple, 7 L 1 ³ / ₈ Long Radius Elbow
	7	Supply	Upper	1 ³ / ₈ Long Radius Elbow 1 ³ / ₈ Nipple, 11 ³ / ₄ L 1 ³ / ₈ Long Radius Elbow
40RM 016	1	Suction	Lower	1 ¹ / ₈ Street Elbow 1 ¹ / ₈ Nipple, 2 ³ / ₄ L 1 ¹ / ₈ Long Radius Elbow
	2	Liquid	Lower	5 ⁵ / ₈ Street Elbow 5 ⁵ / ₈ Nipple, 1 ³ / ₈ L 5 ⁵ / ₈ Long Radius Elbow
	3	Liquid	Upper	5 ⁵ / ₈ Street Elbow 5 ⁵ / ₈ Nipple, 11 ¹ / ₂ L 5 ⁵ / ₈ Long Radius Elbow
	4	Suction	Upper	1 ¹ / ₈ Nipple, 5 ⁵ / ₈ L 1 ¹ / ₈ Long Radius Elbow 1 ¹ / ₈ Nipple, 13 L 1 ¹ / ₈ Long Radius Elbow
40RMQ016, 024,028	3	Suction	Lower	1 ¹ / ₈ Nipple, 3 L 1 ¹ / ₈ Long Radius Elbow
	5	Suction	Lower	5 ⁵ / ₈ Nipple, 2 ⁷ / ₈ L 5 ⁵ / ₈ 45° Elbow 5 ⁵ / ₈ Nipple, 1 ⁵ / ₈ L 5 ⁵ / ₈ Long Radius Elbow
	6	Liquid	Upper	5 ⁵ / ₈ Nipple, 2 ⁷ / ₈ L 5 ⁵ / ₈ 45° Elbow 5 ⁵ / ₈ Nipple, 4 ¹ / ₄ L 5 ⁵ / ₈ Long Radius Elbow
	7	Suction	Upper	1 ¹ / ₈ Nipple, 5 L 1 ¹ / ₈ 45° Elbow 1 ¹ / ₈ Nipple, 8 ³ / ₄ L 1 ¹ / ₈ Long Radius Elbow
40RM 024	1	Suction	Lower	1 ¹ / ₈ Street Elbow 1 ¹ / ₈ Nipple, 7 ⁵ / ₈ L 1 ¹ / ₈ Long Radius Elbow
	2	Liquid	Lower	5 ⁵ / ₈ Street Elbow 5 ⁵ / ₈ Nipple, 6 ¹ / ₂ L 5 ⁵ / ₈ Long Radius Elbow
	3	Liquid	Upper	5 ⁵ / ₈ Street Elbow 5 ⁵ / ₈ Nipple, 9 ¹ / ₂ L 5 ⁵ / ₈ Long Radius Elbow
	4	Suction	Upper	1 ¹ / ₈ Nipple, 5 ⁵ / ₈ L 1 ¹ / ₈ Long Radius Elbow 1 ¹ / ₈ Nipple, 11 L 1 ¹ / ₈ Long Radius Elbow
40RM 028	1	Suction	Lower	1 ³ / ₈ Street Elbow 1 ³ / ₈ Nipple, 11 L 1 ³ / ₈ Long Radius Elbow
	2	Liquid	Lower	5 ⁵ / ₈ Street Elbow 5 ⁵ / ₈ Nipple, 1 ¹ / ₂ L 5 ⁵ / ₈ Long Radius Elbow
	3	Liquid	Upper	5 ⁵ / ₈ Street Elbow 5 ⁵ / ₈ Nipple, 19 ³ / ₄ L 5 ⁵ / ₈ Long Radius Elbow
	4	Suction	Upper	1 ³ / ₈ Nipple, 4 ³ / ₁₆ L 1 ³ / ₈ Long Radius Elbow 1 ³ / ₈ Nipple, 23 ¹ / ₄ L 1 ³ / ₈ Long Radius Elbow

*See Fig. 6 for access hole location by number.

†Fittings are listed in order from header or tee stub connection out to access hole in corner support post.

Table 3 — Fitting Requirements (cont)

UNIT	ACCESS HOLE NO.*	CONNECTION TYPE	CIRCUIT	FITTINGS REQUIRED† (in.)
40RMS 028, 034	5	Supply	Lower	2 ¹ / ₈ Long Radius Elbow 2 ¹ / ₈ Nipple, 3 ¹ / ₂ L 2 ¹ / ₈ Long Radius Elbow
	6	Return	Lower	2 ¹ / ₈ Long Radius Elbow 2 ¹ / ₈ Nipple, 3 L 2 ¹ / ₈ Long Radius Elbow
	7	Return	Upper	2 ¹ / ₈ Long Radius Elbow 2 ¹ / ₈ Nipple, 6 ⁷ / ₈ L 2 ¹ / ₈ Long Radius Elbow
	8	Supply	Upper	2 ¹ / ₈ Long Radius Elbow 2 ¹ / ₈ Nipple, 11 ⁷ / ₈ L 2 ¹ / ₈ Long Radius Elbow
40RM 034	1	Suction	Lower	1 ³ / ₈ Street Elbow 1 ³ / ₈ Nipple, 3 L 1 ³ / ₈ Long Radius Elbow
	2	Liquid	Lower	5 ⁸ / ₈ Street Elbow 5 ⁸ / ₈ Nipple, 7 ³ / ₄ L 5 ⁸ / ₈ Long Radius Elbow
	3	Liquid	Upper	5 ⁸ / ₈ Street Elbow 5 ⁸ / ₈ Nipple, 18 ¹ / ₂ L 5 ⁸ / ₈ Long Radius Elbow
	4	Suction	Upper	1 ³ / ₈ Nipple, 4 ³ / ₁₆ L 1 ³ / ₈ Long Radius Elbow 1 ³ / ₈ Nipple, 19 ¹ / ₄ L 1 ³ / ₈ Long Radius Elbow

*See Fig. 6 for access hole location by number.

†Fittings are listed in order from header or tee stub connection out to access hole in corner support post.

Chilled Water Piping — See Tables 1C and 1F for chilled water connection sizes. For ease in brazing, it is recommended that all internal solder joints be made before unit is placed in final position.

Knockouts are provided in the unit corner posts for 40RM and 40RMQ refrigerant piping; additional field-fabricated access holes are required for 40RMS chilled water piping. See Fig. 6, which lists recommended knockouts and access holes to use for each 40RMS unit size.

To size, design, and install chilled water piping, consult the Carrier System Design manual. See Fig. 12 for an example of a typical installation. Recommended fittings are listed in Table 3.

To access 40RMS coil vents and drains, remove the unit side panel over the coil header. Vent and drain plugs are on the top and bottom of header, respectively. See the Service section for information on preventing coil freeze-up during winter.

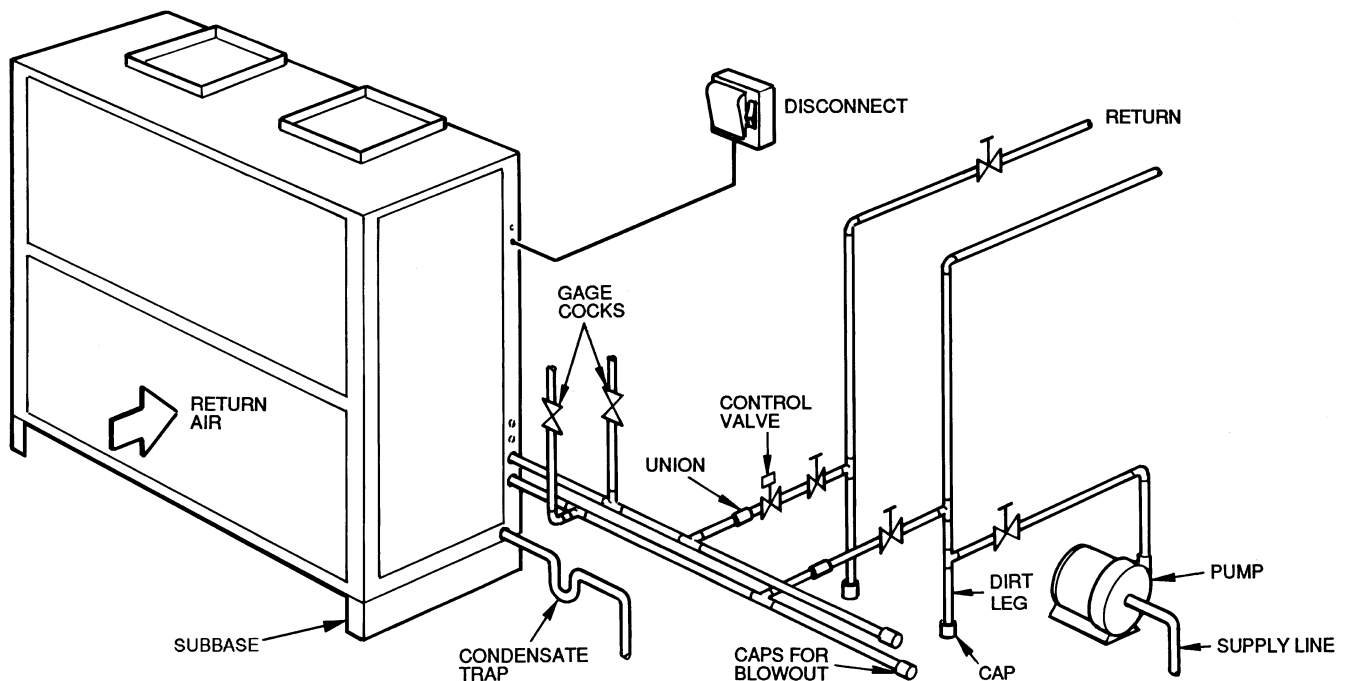

Fig. 12 — Typical 40RMS Chilled Water Piping

Condensate Drain — Install a trapped condensate drain line to unit connection as shown in Fig. 13. The unit drain connection is a PVC stub. See Fig. 14. Some areas may require an adapter to connect to either galvanized steel or copper pipe. For these applications, install a field-supplied threaded PVC adapter.

NOTE: A trap must be installed in the condensate drain line to ensure that the static pressure of fans is balanced with the water column in the drain line and that condensate can drain completely from pan. Without a trap, air can be drawn up drain line until water level in condensate pan becomes equal to static pressure created by fans, preventing complete drainage. Conditions will worsen as filters become dirty.

Install clean-out plugs in trap. Pitch drain line downward to an open floor drain or sump. Provide service clearance around drain line to permit removal of unit panels. Observe all local sanitary codes.

As shipped, the unit's condensate drain pan is NOT sloped towards the drain connection. The pan slope must be changed to pitch towards the side of the unit with the drain connection.

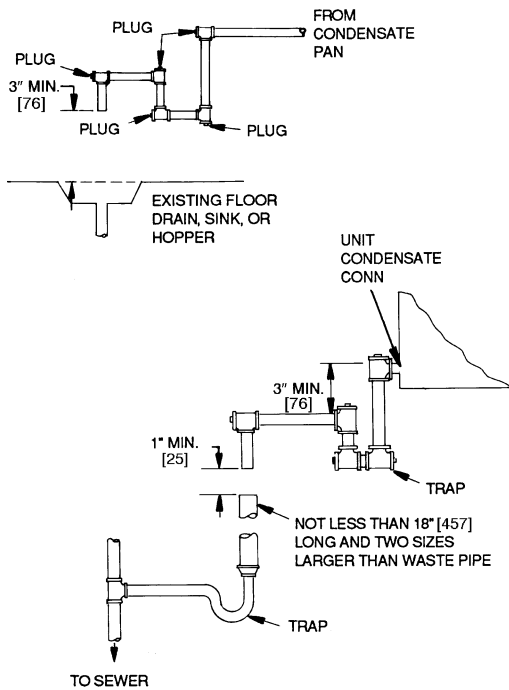

OTE: Dimensions in [] are in millimeters.

Fig. 13 — Condensate Drains

See Fig. 14. Loosen the 2 screws next to the drain outlet at both ends of the unit, push drain pan down in the slots near the drain connection, and up in the slots on the opposite end. Retighten screws. The pan should have a pitch of at least 1/4-in. over its length toward the drain connection.

Fan Motors and Drives — Motor and drive packages are factory installed in all units. The standard motor and drive packages consist of the following items:

- 1 — fan motor
- 1 — adjustable motor pulley
- 1 — fan pulley
- 1 — fan belt (40RM007-012, 40RMQ008-012, 40RMS008-012 units)
- 2 — matched fan belts (40RM014-034, 40RMS014-034, 40RMQ014-028 units)

For instructions on changing fan rotation, changing drive speeds and adjusting drives, see Pulley and Drive Adjustment in the Service section.

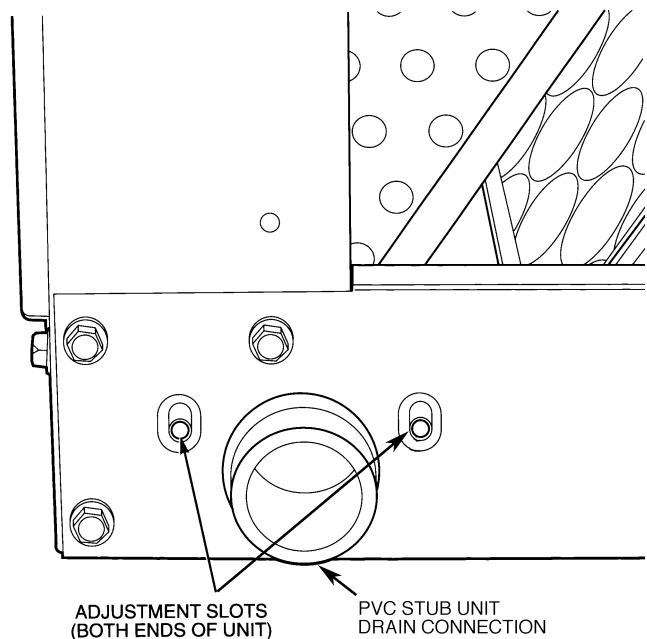

Fig. 14 — Drain Pan Slope Adjustment

Power Supply and Wiring — Check the unit data plate to ensure that available power supply matches electrical characteristics of the unit. Provide a disconnect switch of size required to provide adequate fan motor starting current. See Tables 4-6 for unit electrical data.

Install disconnect switch and power wiring in accordance with all applicable local codes. See Fig. 15-17 and the unit label diagram. For units with motor sizes less than 5 Hp (3.7 kW), connect power wiring to unit with no. 10 ring terminal. For units with motor sizes of 5 Hp (3.7 kW) or more, connect power wiring with 1/4-in. ring terminal.

The 40RM, 40RMQ and 40RMS size 007-016 units (except 40RM016 with YC or WD option) that have motors wired for

460-v, 3-ph, 60 Hz operation can be field-converted to 208/230-v, 3-ph, 60 Hz operation. Rewire the motor according to the diagram plate on the motor. After reconfiguring the motor, mark the motor specifying 208-v or 230-v operation replacing the 460-v sticker information on the units' corner post.

Fan motors are factory-installed on all units. Indoor-fan contactors are located in the fan contactor box behind the side access panel (see Fig. 15 and 16). Wire the thermostat to the 24-v control circuit terminal block located in the side of the fan contactor control box, according to Fig. 17 or the unit label diagram. If the air handler is part of a split system, complete the wiring from the condensing unit to the thermostat shown in Fig. 17.

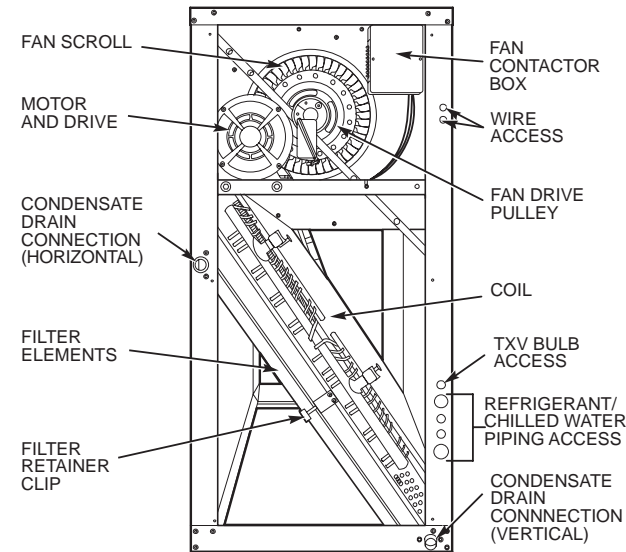

LEGEND

TXV — Thermostatic Expansion Valve

Fig. 15 — Wiring and Service Access (Side Panel Removed)

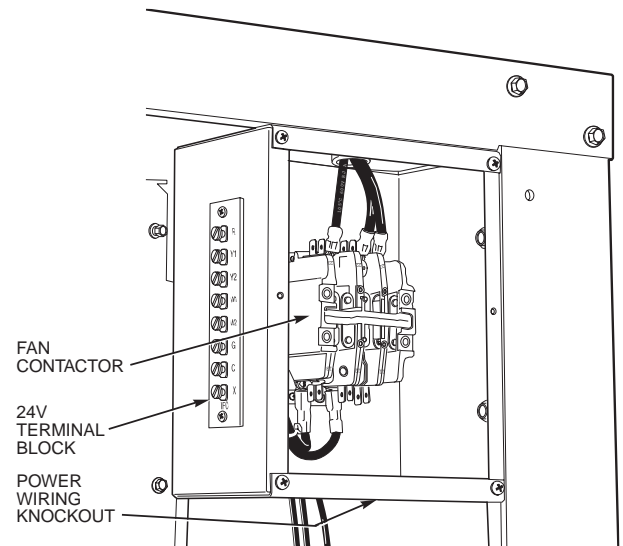

Fig. 16 — Fan Contactor Box and Terminal Block (Cover Removed) (Typical)

Table 4 — Electrical Data, Standard Motors

UNIT	V*-PH-Hz	VOLTAGE LIMITS	FAN MOTOR		POWER SUPPLY	
			Hp (kW)	FLA	Minimum Circuit Amps	MOCP
40RM 007	208/230-1-60	187-253	1.3 (0.97)	7.6	9.5	15
	208/230-3-60	187-253	2.4 (1.79)	5.8	7.3	15
	460-3-60	414-506	2.4 (1.79)	2.6	3.3	15
	575-3-60	518-632	1.0 (0.75)	1.4	1.7	15
	230-3-50	207-253	2.4 (1.79)	5.2	6.5	15
	400-3-50	360-440	2.4 (1.79)	2.6	3.3	15
40RM 40RMQ 40RMS 008	208/230-1-60	187-253	2.4 (1.79)	11.0	13.8	20
	208/230-3-60	187-253	2.4 (1.79)	5.8	7.3	15
	460-3-60	414-506	2.4 (1.79)	2.6	3.3	15
	575-3-60	518-632	2.0 (1.49)	2.4	8.0	15
	230-3-50	207-253	2.4 (1.79)	5.2	6.5	15
	400-3-50	360-440	2.4 (1.79)	2.6	3.3	15
40RMS 010	208/230-1-60	187-253	2.4 (1.79)	11.0	13.8	20
	208/230-3-60	187-253	2.4 (1.79)	5.2	6.5	15
	460-3-60	414-506	2.4 (1.79)	2.6	3.3	15
	575-3-60	518-632	2.0 (1.49)	2.3	2.9	15
	230-3-50	207-253	2.4 (1.79)	5.2	6.5	15
	400-3-50	360-440	2.4 (1.79)	2.6	3.3	15
40RM 40RMQ 40RMS 012	208/230-3-60	187-253	2.4 (1.79)	5.8	7.5	15
	460-3-60	414-506	2.4 (1.79)	2.6	3.3	15
	575-3-60	518-632	2.0 (1.49)	2.4	3.0	15
	230-3-50	207-253	2.9 (2.16)	7.5	9.4	15
	400-3-50	360-440	2.9 (2.16)	3.4	4.3	15
	208/230-3-60	187-253	2.9 (2.16)	7.5	9.4	15
40RM 40RMS 014	460-3-60	414-506	2.9 (2.16)	3.4	4.3	15
	575-3-60	518-632	3.0 (2.24)	3.8	4.8	15
	230-3-50	207-253	2.9 (2.16)	7.5	9.4	15
	400-3-50	360-440	2.9 (2.16)	3.4	4.3	15
	208/230-3-60	187-253	3.7 (2.76)	10.6	13.3	20
	460-3-60	414-506	3.7 (2.76)	4.8	6.0	15
40RM 40RMQ 40RMS 016	575-3-60	518-632	3.0 (2.24)	3.8	4.8	15
	230-3-50	207-253	2.9 (2.16)	7.5	9.4	15
	400-3-50	360-440	2.9 (2.16)	3.4	4.3	15
	208/230-3-60	187-253	5.0 (3.73)	14.6/12.8	18.3/16.0	30/25
	460-3-60	414-506	5.0 (3.73)	6.4	8.0	15
	575-3-60	518-632	5.0 (3.73)	5.1	6.4	15
40RM 40RMQ 40RMS 024	230-3-50	207-253	5.0 (3.73)	15.2	19.0	30
	400-3-50	360-440	5.0 (3.73)	7.6	9.5	15
	208/230-3-60	187-253	7.5 (5.59)	21.4/19.4	26.9/24.3	45/40
	460-3-60	414-506	7.5 (5.59)	9.7	12.1	20
	575-3-60	518-632	7.5 (5.59)	7.8	9.8	15
	230-3-50	207-253	7.5 (5.59)	22.8	28.5	50
40RM 40RMQ 40RMS 028	400-3-50	360-440	7.5 (5.59)	11.4	14.3	25
	208/230-3-60	187-253	10.0 (7.46)	28.2/26.8	35.3/33.5	60/60
	460-3-60	414-506	10.0 (7.46)	13.4	16.8	30
	575-3-60	518-632	10.0 (7.46)	10.3	12.9	20
	230-3-50	207-253	10.0 (7.46)	32.2	40.3	70
	400-3-50	360-440	10.0 (7.46)	16.1	20.1	30

See Legend and Notes on page 23.

Table 5 — Electrical Data, Alternate Motors

UNIT	V ³ -PH-Hz	VOLTAGE LIMITS	FAN MOTOR		POWER SUPPLY	
			Hp (kW)	FLA	Minimum Circuit Amps	MOCP
40RM 007	208/230-1-60	187-253	2.4 (1.79)	11.0/11.0	13.8/13.8	20
	208/230-3-60	187-253	2.9 (2.16)	7.5	9.4	15
	460-3-60	414-506	2.9 (2.16)	3.4	4.3	15
	575-3-60	518-632	2.0 (1.49)	2.4	3.0	15
	230-3-50	207-253	2.4 (1.79)	5.2	6.5	15
	400-3-50	360-440	2.4 (1.79)	2.6	3.3	15
40RM 40RMQ 40RMS 008	208/230-1-60	187-253	2.4 (1.79)	11.0	13.8	15
	208/230-3-60	187-253	2.9 (2.16)	7.5/7.5	9.4/9.4	15
	460-3-60	414-506	2.9 (2.16)	3.4	4.3	15
	575-3-60	518-632	3.0 (2.24)	3.8	4.8	15
	230-3-50	207-253	2.9 (2.16)	7.5	9.4	15
	400-3-50	360-440	2.9 (2.16)	3.4	4.3	15
40RMS 010	208/230-1-60	187-253	2.4 (1.79)	11.0	13.8	20
	208/230-3-60	187-253	2.9 (2.16)	7.5	9.4	15
	460-3-60	414-506	2.9 (2.16)	3.4	4.3	15
	575-3-60	518-632	3.0 (2.24)	3.8	4.8	15
	230-3-50	207-253	2.9 (2.16)	7.5	9.4	15
	400-3-50	360-440	2.9 (2.16)	3.4	4.3	15
40RM 40RMQ 40RMS 012	208/230-3-60	187-253	3.7 (2.76)	10.5/10.5	13.3/13.3	20
	460-3-60	414-506	3.7 (2.76)	4.8	6.0	15
	575-3-60	518-632	3.0 (2.24)	3.8	4.8	15
	230-3-50	207-253	5.0 (3.73)	15.2	19.0	30
	400-3-50	360-440	5.0 (3.73)	7.6	9.5	15
40RM 40RMS 014	208/230-3-60	187-253	3.7 (2.76)	10.2	12.7	20
	460-3-60	414-506	3.7 (2.76)	4.8	6.0	15
	575-3-60	518-632	5.0 (3.73)	5.1	6.4	15
	230-3-50	207-253	5.0 (3.73)	15.2	19.0	30
	400-3-50	360-440	5.0 (3.73)	7.6	9.5	15
40RM 40RMQ 40RMS 016	208/230-3-60	187-253	5.0 (3.73)	14.6/12.8	18.3/16.0	30/25
	460-3-60	414-506	5.0 (3.73)	6.4	8.0	15
	575-3-60	518-632	5.0 (3.73)	5.1	6.4	15
	230-3-50	207-253	5.0 (3.73)	15.2	19.0	30
	400-3-50	360-440	5.0 (3.73)	7.6	9.5	15
40RM 40RMQ 40RMS 024	208/230-3-60	187-253	7.5 (5.59)	21.5/19.4	26.9/24.3	45/40
	460-3-60	414-506	7.5 (5.59)	9.7	12.1	20
	575-3-60	518-632	7.5 (5.59)	7.8	9.8	15
	230-3-50	207-253	7.5 (5.59)	22.8	28.5	50
	400-3-50	360-440	7.5 (5.59)	11.4	14.3	25
40RM 40RMQ 40RMS 028	208/230-3-60	187-253	10.0 (7.46)	28.2/26.8	35.3/33.5	60/60
	460-3-60	414-506	10.0 (7.46)	13.4	16.8	30
	575-3-60	518-632	10.0 (7.46)	10.3	12.9	20
	230-3-50	207-253	10.0 (7.46)	32.2	40.3	60
	400-3-50	360-440	10.0 (7.46)	16.1	20.1	30

Legend and Notes For Tables 4 and 5

LEGEND
FLA — Full Load Amps
MOCP — Maximum Overcurrent Protection

*Motors are designed for satisfactory operation within 10% of nominal voltages shown. Voltages should not exceed the limits shown in the Voltage Limits column.

NOTES:

1. Minimum circuit amps (MCA) and MOCP values are calculated in accordance with NEC (National Electrical Code), Article 440.
2. Motor FLA values are established in accordance with UL (Underwriters' Laboratories) Standard 1995.
3. **Unbalanced 3-Phase Supply Voltage**
Never operate a motor where a phase imbalance in supply voltage is greater than 2%. Use the following formula to determine the percentage of voltage imbalance.

$$= 100 \times \frac{\text{max voltage deviation from average voltage}}{\text{average voltage}}$$

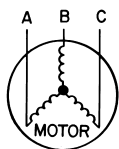

EXAMPLE: Supply voltage is 400-3-50.
 AB = 393 v
 BC = 403 v
 AC = 396 v

$$\begin{aligned} \text{Average Voltage} &= \frac{393 + 403 + 396}{3} \\ &= \frac{1192}{3} \\ &= 397 \end{aligned}$$

Determine maximum deviation from average voltage.

- (AB) 397 - 393 = 4 v
- (BC) 403 - 397 = 6 v
- (AC) 397 - 396 = 1 v

Maximum deviation is 6 v.

Determine percent voltage imbalance.

$$\begin{aligned} \% \text{ Voltage Imbalance} &= 100 \times \frac{6}{397} \\ &= 1.5\% \end{aligned}$$

This amount of phase imbalance is satisfactory because it is below the maximum allowable 2%.

IMPORTANT: If the supply voltage phase imbalance is more than 2%, contact your local electric utility company immediately.

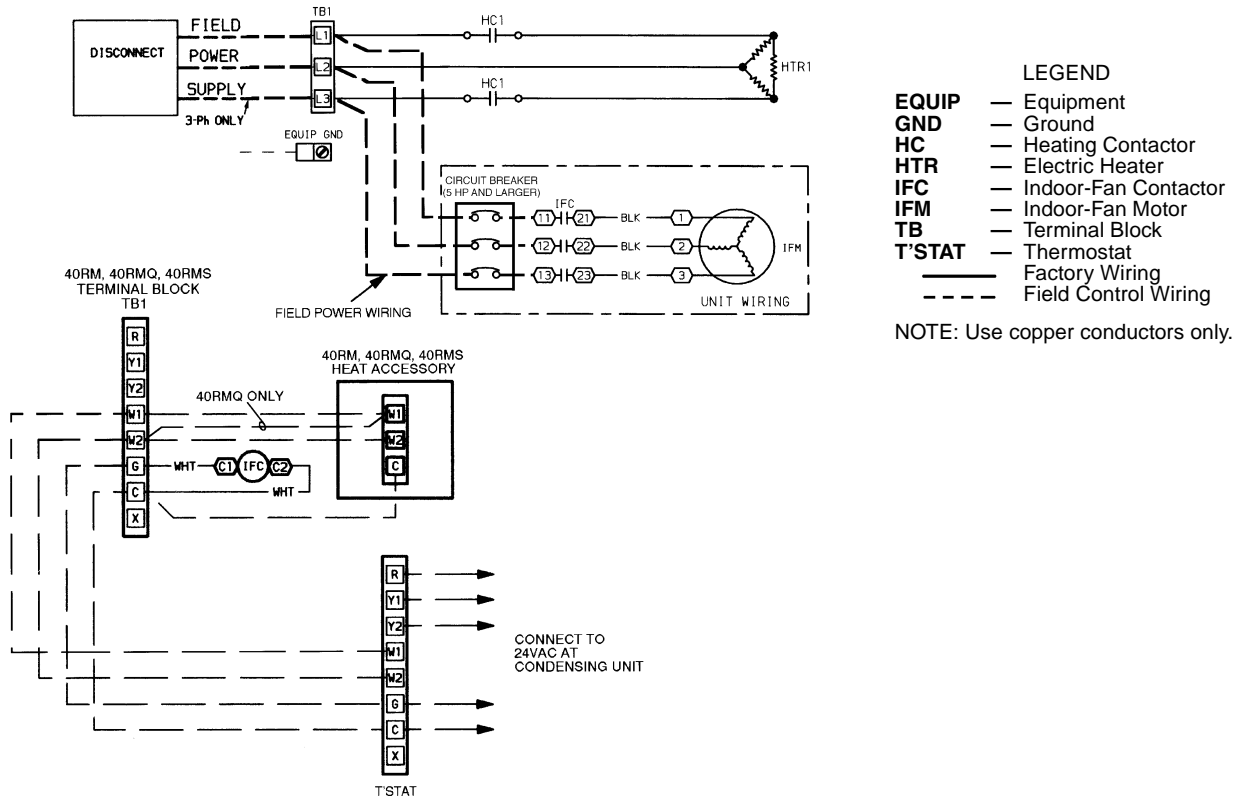

Fig. 17 — Unit Wiring

Table 6 — Fan Contactor Coil Data

UNIT 40RM, 40RMQ 40RMS	VOLTAGE (vac)	MAXIMUM HOLDING VA
007-034	24	10

Connecting Ductwork — Refer to the Carrier System Design Manual for the recommended design and layout of ductwork. Figure 18 shows recommended duct connection to units with 2 fans.

CAUTION

Do not operate unit without ductwork or discharge plenum unless fan speed has been adjusted for external static pressure of zero in. wg. Failure to do so may result in motor overload.

DISCHARGE CONNECTIONS — Duct flanges are factory-supplied; they are shipped inside the unit attached to the hairpin end of the coil tube sheet for field installation. Using the existing screws, install the duct flanges on the unit's fan deck. Each fan discharge requires 2 flanges; each flange must be bent in the middle to conform to the discharge opening. See Fig. 19. After flanges are installed, connect them to the supply duct using a canvas connection to prevent vibration. It is important that this connection be properly fabricated to prevent high air friction losses and air noise.

RETURN CONNECTION — When using return-air ductwork, route return-air duct to the unit's return air inlet near the filter rack, using a canvas connection to prevent transmission of unit vibration. If the duct blocks off the unit's access panel, provide a slip joint in the ductwork to permit removal for servicing.

OUTDOOR-AIR INLET CONNECTION — Connect outdoor-air inlet to field-installed accessory economizer. Refer to Economizer Installation Instructions.

Return-Air Filters — Type and size of filters are shown in Tables 1A-1F and are factory-supplied and factory-installed. In all units with 2 fans, a filter replacement tool (hook) is shipped inside the unit for field use when replacing filters. See the Service section for instructions on filter element replacement.

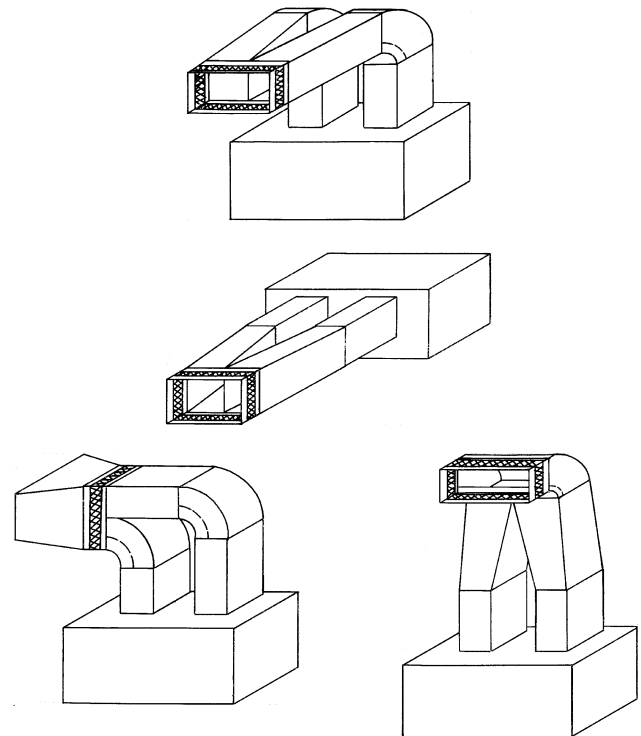

Fig. 18 — Typical Fan Discharge Connections for Multiple Fan Units

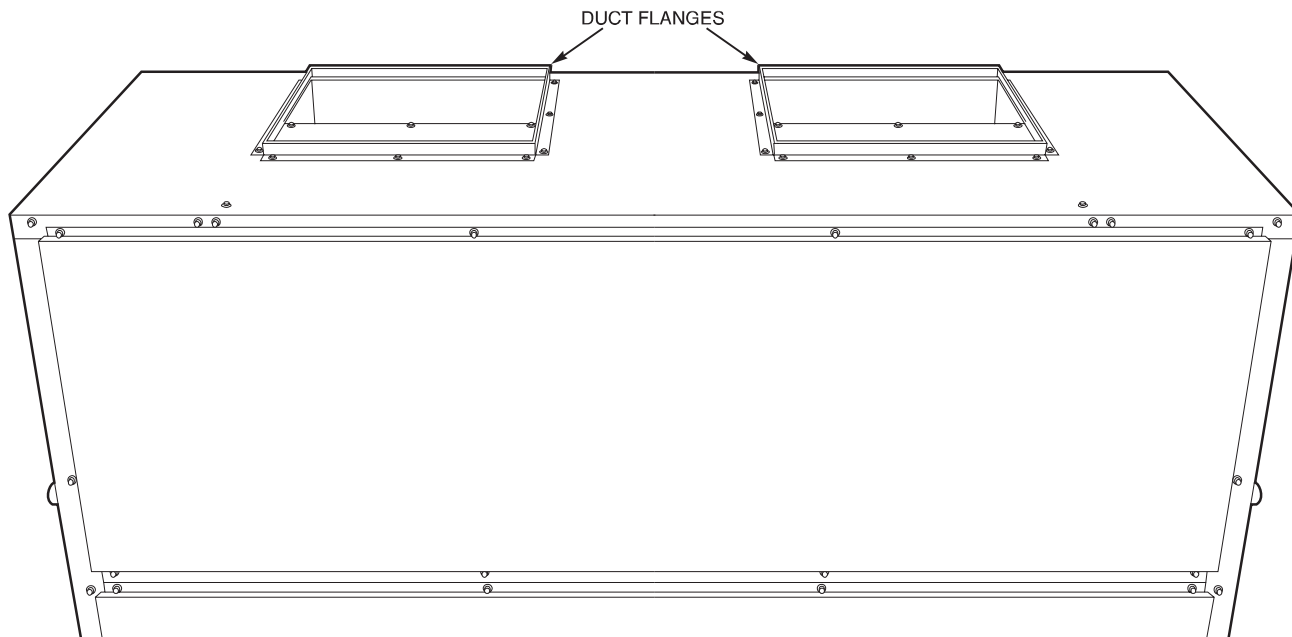

Fig. 19 — Duct Flange Installation

START-UP

Before starting unit, check the following and correct as necessary:

- Is unit solidly supported?
- Is fan adjusted for speed and pulley alignment?
- Are pulleys, motor, and bearings securely mounted?
- Are there any loose parts that will rattle or vibrate?
- Is condensate drain pan pitched for correct drainage?
- Are coil baffle plates tight against coil to prevent air bypass?
- Are all panels securely fastened?
- Are all electrical connections correct and tight?

Also refer to condensing unit instructions before starting a split system. A split system start-up checklist is provided at the end of these instructions.

SERVICE

Inspection and maintenance should be performed at regular intervals and should include the following:

- Complete cleaning of cabinet, fan wheel, cooling coil, condensate pan and drain, heating coils, and return-air grille (if present).
- Inspection of panels and sealing of unit against air leakage.
- Adjustment of fan motor, belt, bearings, and wheels.
- Cleaning or replacement of filters.
- Testing for cooling/heating system leaks.
- Checking of all electrical connections.

Most unit service can be performed by removing one or both of the unit's side panels. Coil cleaning or removal or insulation cleaning may require removal of a rear, top, or bottom panel, depending on the unit's orientation. When service is completed, replace unit panels.

Panels — Panels are fastened to unit frame with sheet metal screws. Fan and coil compartment must be sealed tightly after service to prevent air from bypassing the cooling coil.

Fan Motor Lubrication — Fan motor supplied with unit is permanently lubricated and requires no further lubrication.

Fan Shaft Bearings — Bearings on size 007-012 units are sealed, permanently lubricated bearings that require no further lubrication. Size 014-034 units have pillow-block bearings (Fig. 20) that must be lubricated with suitable bearing grease approximately every 3 months. See Table 7 for suitable lubricants.

Table 7 — Lubricant Data

MANUFACTURER	LUBRICANT
Mobil	Mobilplex EP No. 2
Sunoco	Prestige 42
Texaco	Multifak 2
Texaco	Regal AFB-2*

*Preferred lubricant because it contains rust and oxidation inhibitors.

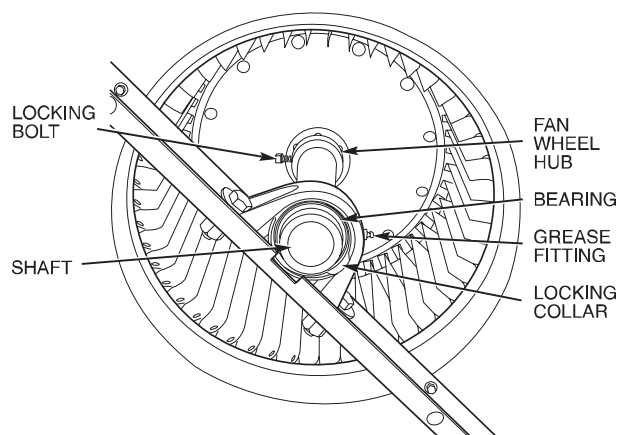

Fig. 20 — Fan Shaft, Bearings, and Fan Wheel (Typical)

Centering Fan Wheel — If fan and fan shaft assembly are not properly centered, blades may scrape against scroll or may create an objectionable whistling noise. It may be necessary to adjust individual fan wheels or move entire fan shaft. See the following two sections.

Fan Shaft Position Adjustment — Loosen setscrew or locking collar of each fan shaft bearing. Slide shaft into correct position and replace locking collar (Fig. 21). To replace locking collar, push collar up against inner face of bearing. Turn collar in direction of fan rotation until tight, and tighten setscrew. Tightening locking collar in direction of fan rotation results in further tightening of collar should setscrew work itself loose.

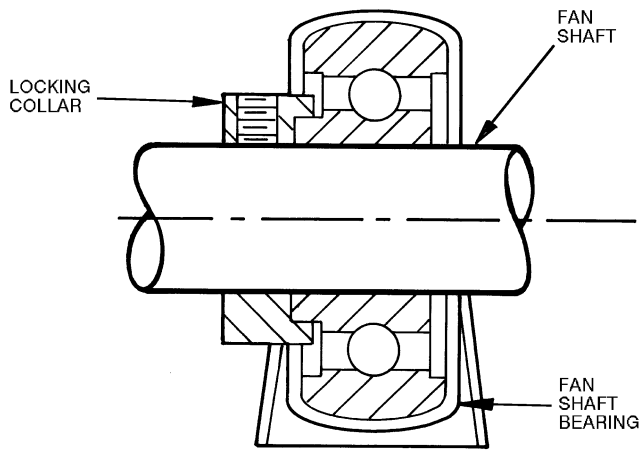

Fig. 21 — Fan Shaft Bearing

Individual Fan Wheel Adjustment — Loosen the 2 locking bolts holding fan wheel hub to shaft. See Fig. 20. Position fan wheel in center of the fan housing and tighten locking bolts. Clearance between wheel and housing should be the same on both sides.

Fan Belts — Motor mounting plate and motor support angles are slotted to permit both vertical and horizontal adjustment. Adjust belt(s) for correct deflection by loosening motor plate mounting bolts, moving motor/plate assembly forward or back, and retightening bolts. Press down on belt with one finger midway between fan and motor pulleys to check deflection. For units with motor sizes up to and including 3.7 Hp (2.76 kW), correct deflection is $3/16$ -in. (4.8 mm). For larger motor sizes, correct deflection is $1/8$ -in. (3.2 mm). See Fig. 22.

NOTE: The 028 and 034 size units with 60 Hz motors (standard or medium static drive) are shipped with an extra set of belts. Use the preinstalled belts or extra belts depending on the adjustable pulley setting.

If complete belt replacement is required during servicing, loosen the motor plate mounting bolts (Fig. 22), move motor/plate assembly towards fan pulley, and pull belt(s) off pulleys. Reverse the procedure with new bolts and readjust deflection.

Fan Rotation — Correct fan rotation with respect to fan outlet is shown in Fig. 23.

To reverse the direction of rotation of a 3-phase fan motor, reverse any 2 of the power leads. Refer to the connection diagram on the inside of motor terminal box cover for proper reversing procedure of single-phase motor.

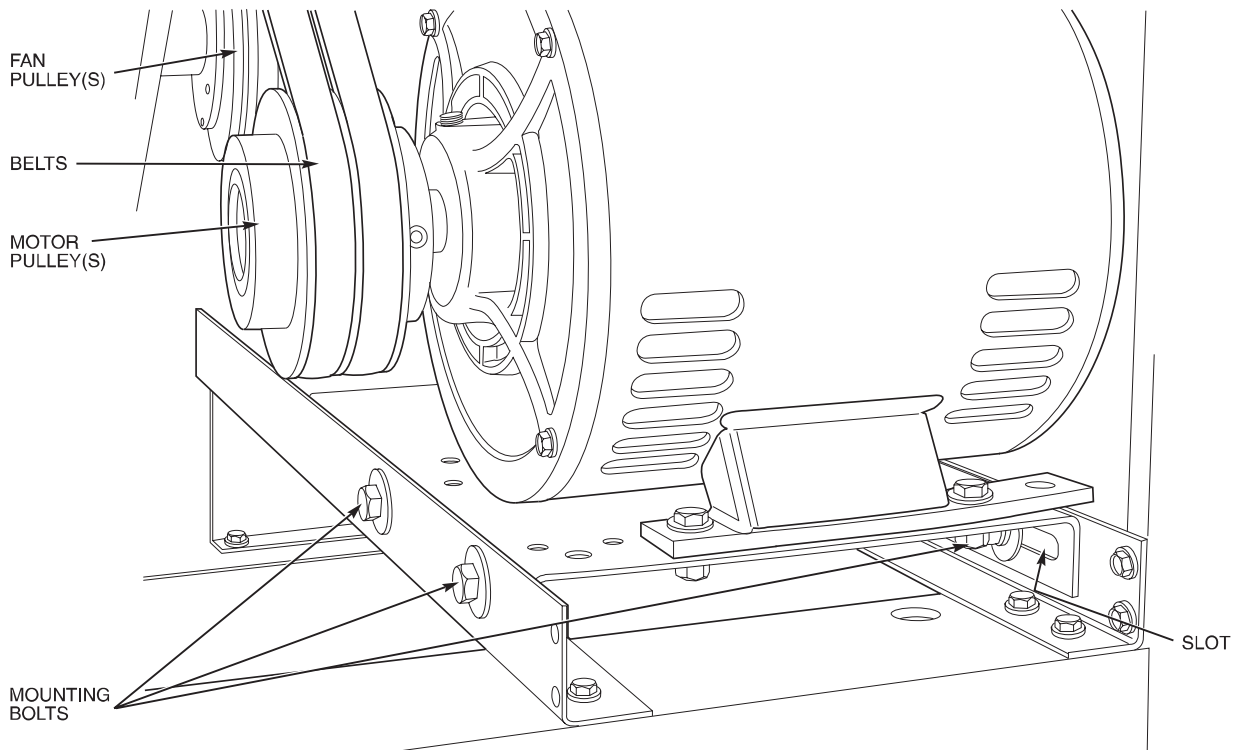

Fig. 22 — Fan Motor Mounting

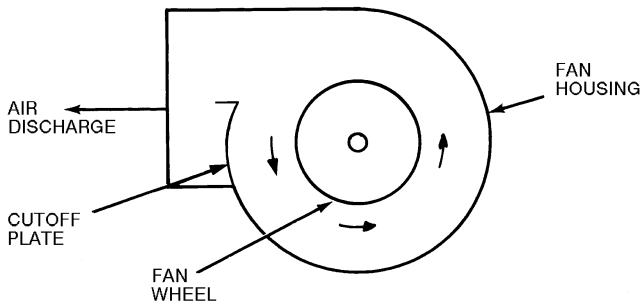

Fig. 23 — Fan Rotation

Fan Pulley Alignment — Align as follows:

1. Loosen setscrews on pulleys.
2. Align pulleys visually and tighten setscrews on fan pulley to lock it in place.
3. Use the methods shown in Fig. 24 to check proper pulley alignment.
4. If pulleys are not in correct alignment, loosen the motor holddown bolts and slide the motor axially until the pulleys are aligned.
5. Tighten motor holddown bolts.

Pulley and Drive Adjustment — To obtain desired fan speed, refer to the fan motor and drive data in Tables 8A-11D and adjust fan motor pulley as follows:

1. Remove belt from fan motor pulley after loosening motor from motor base.
2. Loosen setscrew in moveable flange of pulley. Screw moveable flange toward fixed flange to increase the fan speed and away from fixed flange to reduce speed. Before tightening setscrew, make certain that setscrew is over nearest flat surface of pulley hub (Fig. 24).

⚠ CAUTION

Increasing fan speed produces a greater load on motor. Do not exceed rated capacity of motor.

Condensate Drains — Keep condensate drains free of dirt and foreign matter.

Return-Air Filters — Refer to Replacing Filters section for filter accessibility and removal. Replace with clean filters of the sizes listed in Tables 1A-1F.

Chilled Water Coil Freeze Protection — Shut off water supply to unit. Remove side panel of unit and remove vent and drain plugs in top and bottom of coil header. Drain coil and blow out remaining water. Reinstall plugs and side panel.

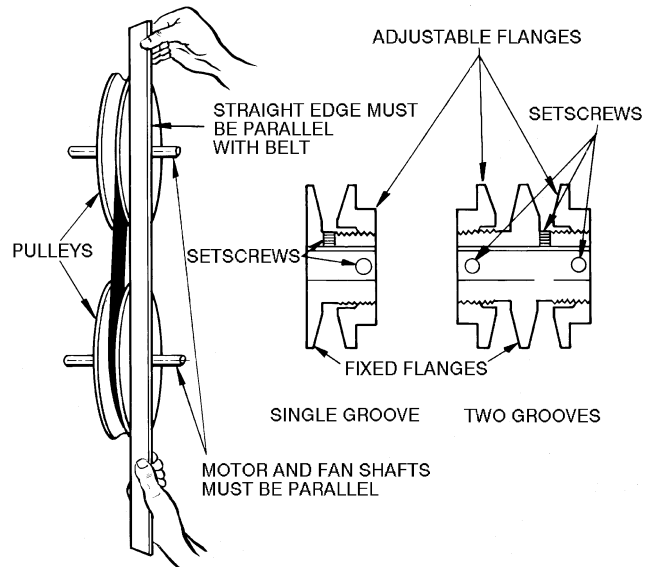

Fig. 24 — Fan Pulley Adjustments

Alternative freeze protection methods follow:

- Circulate hot water within the water coil's supply main or supplementary space heating.
- Close off supply lines to unit and open a union or field-supplied drain valve in the return line.

IMPORTANT: Draining from return line will not completely drain water from coils.

- After draining as much water as possible from coils, add sufficient antifreeze to prevent residual water in the coil from freezing.
- Add a sufficient quantity of non-corrosive antifreeze to the entire system to prevent all water within the system from freezing.

Coil Removal — Remove unit panels and corner posts as required. Disconnect coil connections and remove fastening screws. Remove coil through end or side sections of unit.

Cleaning Cooling Coil — Remove return-air filters. Remove any heavy dirt that may have accumulated on underside of coil. Coil can be cleaned more easily with a stiff brush, vacuum cleaner, or compressed air when coil is dry. If coil is wet or if water is to be used for cleaning, guard against splashing water on electrical components or damaging surrounding area. Clean coil baffles as applicable and check for tight fit to be sure air does not bypass coil.

Cleaning Insulation — The insulation contains an immobilized antimicrobial agent that helps prevent the growth of bacteria and fungi. Clean the inner surface of the insulation according to the separate maintenance instructions shipped with the unit.

Replacing Filters — Filters can be removed and installed from either side of the unit. Install new filters in units that have one fan as follows:

1. Remove the side access panel (retain screws).
2. Remove the filter retainer clip (see Fig. 25).
3. Remove old filters by lifting and tilting them out of the filter track. See Fig. 15 and 26.
4. Reverse the procedure to install new filters.

To install new filters in larger units that have 2 fans, follow the preceding steps, but use the factory-supplied filter hook to slide filters within reach for removal. The filter hook is shipped inside the unit in the filter track.

⚠ CAUTION
Do not operate unit without air filters.

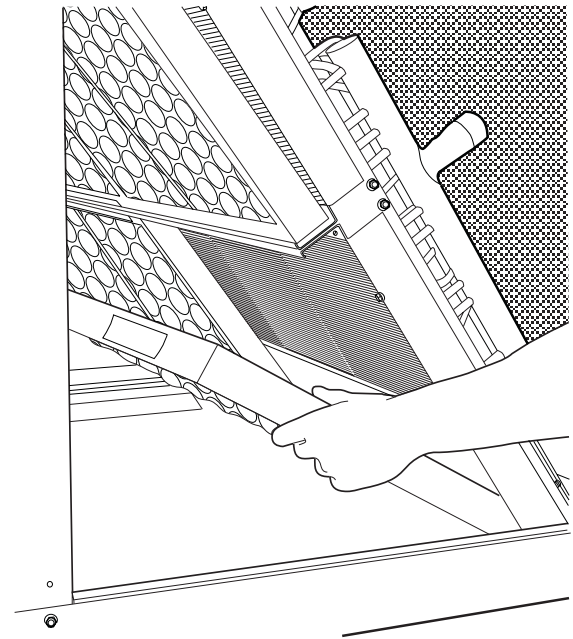

Fig. 26 — Filter Removal/Replacement

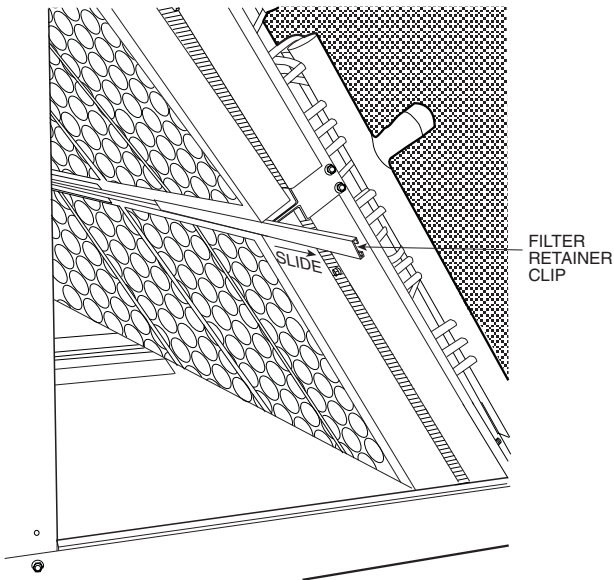

Fig. 25 — Remove Filter Retainer Clip

Table 8A — Fan Motor Data, Standard Motor — English

UNIT	40RM 007	40RM 40RMQ 40RMS 008	40RMS 010	40RM 40RMQ 40RMS 012	40RM 40RMS 014	40RM 40RMQ 40RMS 016	40RM 40RMQ 40RMS 024	40RM 40RMQ 40RMS 028	40RM 40RMS 034
208/230-1-60									
Speed (rpm)	1725	1725	1725	—	—	—	—	—	—
Hp	1.3	2.4	2.4	—	—	—	—	—	—
Frame (NEMA)	56Y	56Y	56Y	—	—	—	—	—	—
Shaft Dia (in.)	5/8	5/8	5/8	—	—	—	—	—	—
208/230-3-60 and 460-3-60									
Speed (rpm)	1725	1725	1725	1725	1725	1725	1745	1745	1745
Hp	2.4	2.4	2.4	2.4	2.9	3.7	5.0	7.5	10.0
Frame (NEMA)	56Y	56Y	56Y	56Y	56Y	56Y	S184T	S213T	S215T
Shaft Dia (in.)	5/8	5/8	5/8	5/8	7/8	7/8	1 1/8	1 3/8	1 3/8
575-3-60									
Speed (rpm)	1725	1725	1725	1725	1725	1725	1745	1755	1755
Hp	1.0	2.0	2.0	2.0	3.0	3.0	5.0	7.5	10.0
Frame (NEMA)	56	56HZ	56HZ	56HZ	56HZ	56HZ	184T	S213T	D215T
Shaft Dia (in.)	5/8	7/8	7/8	7/8	7/8	7/8	1 1/8	1 3/8	1 3/8
230-3-50 and 400-3-50									
Speed (rpm)	1425	1425	1425	1425	1425	1425	1425	1425	1425
Hp	2.4	2.4	2.4	2.9	2.9	2.9	5.0	7.5	10.0
Frame (NEMA)	56Y	56Y	56Y	56Y	56Y	56Y	184T	S213T	S215T
Shaft Dia (in.)	5/8	5/8	5/8	7/8	7/8	7/8	1 1/8	1 3/8	1 3/8

LEGEND

NEMA — National Electrical Manufacturers Association

Table 8B — Fan Motor Data, Alternate Motor — English

UNIT	40RM 007	40RM 40RMQ 40RMS 008	40RMS 010	40RM 40RMQ 40RMS 012	40RM 40RMS 014	40RM 40RMQ 40RMS 016	40RM 40RMQ 40RMS 024	40RM 40RMQ 40RMS 028
208/230-1-60								
Speed (rpm)	1725	1725	1725	—	—	—	—	—
Hp	2.4	2.4	2.4	—	—	—	—	—
Frame (NEMA)	56Y	56Y	56Y	—	—	—	—	—
Shaft Dia (in.)	5/8	5/8	5/8	—	—	—	—	—
208/230-3-60 and 460-3-60								
Speed (rpm)	1725	1725	1725	1725	1725	1725	1745	1745
Hp	2.9	2.9	2.9	3.7	3.7	5.0	7.5	10.0
Frame (NEMA)	56Y	56Y	56Y	Y56Y	Y56Y	S184T	S213T	S215T
Shaft Dia (in.)	7/8	7/8	7/8	7/8	7/8	1 1/8	1 3/8	1 3/8
575-3-60								
Speed (rpm)	1725	1725	1725	1725	1745	1745	1755	1750
Hp	2.0	3.0	3.0	3.0	5.0	5.0	7.5	10.0
Frame (NEMA)	56HZ	56HZ	56HZ	56HZ	184T	184T	S213T	D215T
Shaft Dia (in.)	7/8	7/8	7/8	7/8	1 1/8	1 1/8	1 3/8	1 3/8
230-3-50 and 400-3-50								
Speed (rpm)	1425	1425	1425	1425	1425	1425	1425	1425
Hp	2.4	2.9	2.9	5.0	5.0	5.0	7.5	10.0
Frame (NEMA)	56Y	56Y	56Y	S184T	S184T	S184T	S213T	S215T
Shaft Dia (in.)	7/8	7/8	7/8	7/8	1 1/8	1 1/8	1 3/8	1 3/8

LEGEND

NEMA — National Electrical Manufacturers Association

Table 8C — Fan Motor Data, Standard Motor — SI

UNIT	40RM 007	40RM 40RMQ 40RMS 008	40RMS 010	40RM 40RMQ 40RMS 012	40RM 40RMS 014	40RM 40RMQ 40RMS 016	40RM 40RMQ 40RMS 024	40RM 40RMQ 40RMS 028	40RM 40RMS 034
208/230-1-60									
Speed (r/s)	28.75	28.75	28.75	—	—	—	—	—	—
Shaft kW	0.97	1.79	1.79	—	—	—	—	—	—
Frame (NEMA)	56Y	56Y	56Y	—	—	—	—	—	—
Shaft Dia (mm)	15.9	15.9	15.9	—	—	—	—	—	—
208/230-3-60 and 460-3-60									
Speed (r/s)	28.75	28.75	28.75	28.75	28.75	28.75	29.08	29.08	29.08
Shaft kW	1.79	1.79	1.79	1.79	2.16	2.76	3.73	5.60	7.46
Frame (NEMA)	56Y	56Y	56Y	56Y	56Y	56Y	S184T	S213T	S215T
Shaft Dia (mm)	15.9	15.9	15.9	15.9	22.2	22.2	28.6	34.9	34.9
575-3-60									
Speed (r/s)	28.75	28.75	28.75	28.75	28.75	28.75	29.08	29.25	29.25
Shaft kW	0.746	1.49	1.49	1.49	2.24	2.24	3.73	5.60	7.46
Frame (NEMA)	56	56HZ	56HZ	56HZ	56HZ	56HZ	184T	S213T	S215T
Shaft Dia (mm)	15.9	22.2	22.2	22.2	22.2	22.2	28.6	34.9	34.9
230-3-50 and 400-3-50									
Speed (r/s)	23.75	23.75	23.75	23.75	23.75	23.75	23.75	23.75	23.75
Shaft kW	1.79	1.79	1.79	2.16	2.16	2.16	3.73	5.60	7.46
Frame (NEMA)	56Y	56Y	56Y	56Y	56Y	56Y	184T	S213T	S215T
Shaft Dia (mm)	15.9	15.9	15.9	22.2	22.2	22.2	28.6	34.9	34.9

LEGEND

NEMA — National Electrical Manufacturers Association

Table 8D — Fan Motor Data, Alternate Motor — SI

UNIT	40RM 007	40RM 40RMQ 40RMS 008	40RMS 010	40RM 40RMQ 40RMS 012	40RM 40RMS 014	40RM 40RMQ 40RMS 016	40RM 40RMQ 40RMS 024	40RM 40RMQ 40RMS 028
208/230-1-60								
Speed (r/s)	28.75	28.75	28.75	—	—	—	—	—
Shaft kW	1.79	1.79	1.79	—	—	—	—	—
Frame (NEMA)	56Y	56Y	56Y	—	—	—	—	—
Shaft Dia (mm)	15.9	15.9	15.9	—	—	—	—	—
208/230-3-60 and 460-3-60								
Speed (r/s)	28.75	28.75	28.75	28.75	28.75	29.08	29.08	29.17
Shaft kW	2.16	2.16	2.16	2.76	2.76	3.73	5.60	7.46
Frame (NEMA)	56Y	56Y	56Y	Y56Y	Y56Y	S184T	S213T	S215T
Shaft Dia (mm)	22.2	22.2	22.2	22.2	22.2	28.6	34.9	34.9
575-3-60								
Speed (r/s)	28.75	28.75	28.75	28.75	29.08	29.08	29.25	29.17
Shaft kW	1.49	2.24	2.24	2.24	3.73	3.73	5.60	7.46
Frame (NEMA)	56HZ	56HZ	56HZ	56HZ	184T	184T	S213T	D215T
Shaft Dia (mm)	22.2	22.2	22.2	22.2	28.6	28.6	34.9	34.9
230-3-50 and 400-3-50								
Speed (r/s)	23.75	23.75	23.75	23.75	23.75	23.75	23.75	23.75
Shaft kW	1.79	2.16	2.16	3.73	3.73	3.73	5.60	7.46
Frame (NEMA)	56Y	56Y	56Y	S184T	S184T	S184T	S213T	S215T
Shaft Dia (mm)	22.2	22.2	22.2	22.2	28.6	28.6	34.9	34.9

LEGEND

NEMA — National Electrical Manufacturers Association

Table 9A — Standard Drive Data, 60 Hz — English

UNIT	40RM 007	40RM 40RMQ 40RMS 008	40RMS 010	40RM 40RMQ 40RMS 012	40RM 40RMS 014	40RM 40RMQ 40RMS 016	40RM 40RMQ 40RMS 024	40RM 40RMQ 40RMS 028	40RM 40RMS 034
MOTOR DRIVE									
Motor Pulley Pitch Diameter (in.)	2.4-3.4	2.8-3.8	2.8-3.8	3.4-4.4	2.8-3.8	2.8-3.8	3.7-4.7	4.3-5.3	4.3-5.3
Pulley Factory Setting Full Turns Open	2.5	2.5	2.5	2.5	2.5	2.5	3.0	3.0	3.0
FAN DRIVE									
Pulley Pitch Dia (in.)	8.8	8.8	8.8	8.8	9.0	9.0	9.4	11.0	11.0
Pulley Bore (in.)	1	1	1	1	17/16	17/16	17/16	115/16	115/16
Belt No. — Section	1—A	1—A	1—A	1—A	1—A	1—A	2—B	2—B*	2—B*
Belt Pitch (in.)	40.3	41.3	41.3	42.3	42.3	42.3	41.8	(2) 42.8 (2) 43.8	(2) 42.8 (2) 43.8
FAN SPEEDS (rpm)									
Factory Setting	568	647	647	764	632	632	771	752	752
Range	470-666	549-745	549-745	666-863	537-728	537-728	679-863	682-841	674-831
Max Allowable Speed (rpm)	1200	1200	1200	1200	1200	1200	1200	1100	1100
Change per 1/2 Turn of Moveable Motor Pulley Flange	19.6	19.6	19.6	19.7	19.1	19.1	15.3	13.1	13.1
MAX FULL TURNS FROM CLOSED POSITION	5	5	5	5	5	5	6	6	6
SHAFTS CENTER DISTANCE (in.)	10.44- 12.32	10.44- 12.32	10.44- 12.32	10.44- 12.32	10.44- 12.32	10.44- 12.32	9.12- 10.99	6.67- 9.43	6.67- 9.43

*Four belts shipped with unit. Use correct set of 2 belts sized according to the pulley setting.

Table 9B — Medium-Static Drive Data, 60 Hz — English

UNIT	40RM 007	40RM 40RMQ 40RMS 008	40RMS 010	40RM 40RMQ 40RMS 012	40RM 40RMS 014	40RM 40RMQ 40RMS 016	40RM 40RMQ 40RMS 024	40RM 40RMQ 40RMS 028	40RM 40RMS 034
MOTOR DRIVE									
Motor Pulley Pitch Diameter (in.)	3.4-4.4	3.4-4.4	3.4-4.4	3.4-4.4	3.4-4.4	3.7-4.7	4.3-5.3	4.3-5.3	4.3-5.3
Pulley Factory Setting Full Turns Open	2.5	2.5	2.5	2.5	2.5	3.0	3.0	3.0	3.0
FAN DRIVE									
Pulley Pitch Dia (in.)	8.8	8.0	8.0	8.0	8.2	8.6	9.4	9.4	9.4
Pulley Bore (in.)	1	1	1	1	17/16	17/16	17/16	115/16	115/16
Belt No. — Section	1—A	1—A	1—A	1—A	1—A	1—B	1—B	2—B*	2—B*
Belt Pitch (in.)	42.3	40.3	40.3	40.3	41.3	41.8	41.8	(2) 38.8 (2) 39.8	(2) 38.8 (2) 39.8
FAN SPEEDS (rpm)									
Factory Setting	764	841	841	841	820	842	881	881	881
Range	666-863	733-949	733-949	733-949	715-926	742-943	798-984	798-984	798-984
Max Allowable Speed (rpm)	1200	1200	1200	1200	1200	1200	1200	1100	1100
Change per 1/2 Turn of Moveable Motor Pulley Flange	19.7	21.6	21.6	21.6	21.1	16.7	15.3	15.3	15.3
MAX FULL TURNS FROM CLOSED POSITION	5	5	5	5	5	6	6	6	6
SHAFTS CENTER DISTANCE (in.)	10.44- 12.32	10.44- 12.32	10.44- 12.32	10.44- 12.32	10.44- 12.32	10.44- 12.32	9.16- 10.99	6.67- 9.43	6.67- 9.43

*Four belts shipped with unit. Use correct set of 2 belts sized according to the pulley setting.

Table 9C — High-Static Drive Data, 60 Hz — English

UNIT	40RM 007	40RM 40RMQ 40RMS 008	40RMS 010	40RM 40RMQ 40RMS 012	40RM 40RMS 014	40RM 40RMQ 40RMS 016	40RM 40RMQ 40RMS 024	40RM 40RMQ 40RMS 028	40RM 40RMS 034
MOTOR DRIVE									
Motor Pulley Pitch Diameter (in.)	3.4-4.4	3.4-4.4	3.4-4.4	3.4-4.4	3.7-4.7	4.3-5.3	4.3-5.3	4.3-5.3	4.3-5.3
Pulley Factory Setting Full Turns Open	2.5	2.5	2.5	2.5	3.0	3.0	3.0	3.0	3.0
FAN DRIVE									
Pulley Pitch Dia (in.)	7.0	6.0*	6.0	6.0	7.4	7.9	7.4	8.6	8.6
Pulley Bore (in.)	1	1	1	1	1 ⁷ / ₁₆	1 ⁷ / ₁₆	1 ⁷ / ₁₆	1 ¹⁵ / ₁₆	1 ¹⁵ / ₁₆
Belt No. — Section	1—A	1—A	1—A	1—A	1—B	1—B	2—B	2—B	2—B
Belt Pitch (in.)	41.3	37.3	37.3	37.3	39.8	39.8	36.8	37.8	37.8
FAN SPEEDS (rpm)									
Factory Setting	961	1121	1121	1121	979	1060	1118	1024	1024
Range	838-1084	978-1200*†	978-1200†	978-1200†	873-1096	950-1171	1014-1200†	873-1075	873-1075
Max Allowable Speed (rpm)	1200	1200	1200	1200	1200	1200	1200	1100	1100
Change per 1/2 Turn of Moveable Motor Pulley Flange	24.6	28.7	28.7	28.7	19.4	18.4	19.4	16.7	16.7
MAX FULL TURNS FROM CLOSED POSITION	5	5	5	5	6	6	6	6	6
SHAFTS CENTER DISTANCE (in.)	10.44-12.32	10.44-12.32	10.44-12.32	10.44-12.32	10.44-12.32**	9.16-10.99	8.16-10.02	6.67-9.43	6.67-9.43

*Values for 3-phase motor shown. For single-phase motor, pulley pitch diameter is 7 in. and resulting fan speed is 837-1096 rpm.

†It is possible to adjust drive so that fan speed exceeds maximum allowable. DO NOT exceed 1200 rpm.

**575-v unit has a center distance of 9.16-10.99.

Table 9D — Standard Drive Data, 60 Hz — SI

UNIT	40RM 007	40RM 40RMQ 40RMS 008	40RMS 010	40RM 40RMQ 40RMS 012	40RM 40RMS 014	40RM 40RMQ 40RMS 016	40RM 40RMQ 40RMS 024	40RM 40RMQ 40RMS 028	40RM 40RMS 034
MOTOR DRIVE									
Motor Pulley Pitch Diameter (mm)	61.0-86.4	71.1-96.5	71.1-96.5	86.4-111.8	71.1-96.5	71.1-96.5	94.0-119.4	109.2-134.6	109.2-134.6
Pulley Factory Setting Full Turns Open	2.5	2.5	2.5	2.5	2.5	2.5	3.0	3.0	3.0
FAN DRIVE									
Pulley Pitch Dia (mm)	224	224	224	224	229	229	239	279	279
Pulley Bore (mm)	25.4	25.4	25.4	25.4	36.5	36.5	36.5	49.2	49.2
Belt No. — Section	1—A	1—A	1—A	1—A	1—A	1—A	2—B	2—B*	2—B*
Belt Pitch (mm)	1024	1049	1049	1074	1074	1074	1062	(2) 1087 (2) 1113	(2) 1087 (2) 1113
FAN SPEEDS (r/s)									
Factory Setting	9.5	10.8	10.8	12.7	10.5	10.5	12.9	12.5	12.5
Range	7.8-11.1	9.2-12.4	9.2-12.4	11.1-14.4	9.0-12.1	9.0-12.1	11.3-14.4	11.4-14.0	11.2-13.9
Max Allowable Speed (r/s)	20.0	20.0	20.0	20.0	20.0	20.0	20.0	18.3	18.3
Change per 1/2 Turn of Moveable Motor Pulley Flange	0.327	0.327	0.327	0.328	0.318	0.318	0.255	0.218	0.218
MAX FULL TURNS FROM CLOSED POSITION	5	5	5	5	5	5	6	6	6
SHAFTS CENTER DISTANCE (mm)	265-313	265-313	265-313	265-313	265-313	265-313	232-279	169-240	169-240

*Four belts shipped with unit. Use correct set of 2 belts sized according to the pulley setting.

Table 9E — Medium-Static Drive Data, 60 Hz — SI

UNIT	40RM 007	40RM 40RMQ 40RMS 008	40RMS 010	40RM 40RMQ 40RMS 012	40RM 40RMS 014	40RM 40RMQ 40RMS 016	40RM 40RMQ 40RMS 024	40RM 40RMQ 40RMS 028	40RM 40RMS 034
MOTOR DRIVE									
Motor Pulley Pitch Diameter (mm)	86.4-111.8	86.4-111.8	86.4-111.8	86.4-111.8	86.4-111.8	94.0-119.4	109.2-134.6	109.2-134.6	109.2-134.6
Pulley Factory Setting Full Turns Open	2.5	2.5	2.5	2.5	2.5	3.0	3.0	3.0	3.0
FAN DRIVE									
Pulley Pitch Dia (mm)	224	203	203	203	208	218	239	239	239
Pulley Bore (mm)	25.4	25.4	25.4	25.4	36.5	36.5	36.5	49.2	49.2
Belt No. — Section	1—A	1—A	1—A	1—A	1—A	1—B	1—B	2—B*	2—B*
Belt Pitch (mm)	1074	1024	1024	1024	1049	1062	1062	(2) 986 (2) 1011	(2) 986 (2) 1011
FAN SPEEDS (r/s)									
Factory Setting	12.7	14.0	14.0	14.0	13.7	14.0	14.7	14.7	14.7
Range	11.1-14.4	12.2-15.8	12.2-15.8	12.2-15.8	11.9-15.4	12.4-15.7	13.3-16.4	13.3-16.4	13.3-16.4
Max Allowable Speed (r/s)	20.0	20.0	20.0	20.0	20.0	20.0	20.0	18.3	18.3
Change per 1/2 Turn of Moveable Motor Pulley Flange	0.328	0.360	0.360	0.360	0.352	0.278	0.255	0.255	0.255
MAX FULL TURNS FROM CLOSED POSITION	5	5	5	5	5	6	6	6	6
SHAFTS CENTER DISTANCE (mm)	265-313	265-313	265-313	265-313	265-313	265-313	232-279	169-240	169-240

*Four belts shipped with unit. Use correct set of 2 belts sized according to the pulley setting.

Table 9F — High-Static Drive Data, 60 Hz — SI

UNIT	40RM 007	40RM 40RMQ 40RMS 008	40RMS 010	40RM 40RMQ 40RMS 012	40RM 40RMS 014	40RM 40RMQ 40RMS 016	40RM 40RMQ 40RMS 024	40RM 40RMQ 40RMS 028	40RM 40RMS 034
MOTOR DRIVE									
Motor Pulley Pitch Diameter (mm)	86.4-111.8	86.4-111.8	86.4-111.8	86.4-111.8	94.0-119.4	109.2-134.6	109.2-134.6	109.2-134.6	109.2-134.6
Pulley Factory Setting Full Turns Open	2.5	2.5	2.5	2.5	3.0	3.0	3.0	3.0	3.0
FAN DRIVE									
Pulley Pitch Dia (mm)	178	152*	152	152	188	201	188	203	203
Pulley Bore (mm)	25.4	25.4	25.4	25.4	36.5	36.5	36.5	49.2	49.2
Belt No. — Section	1—A	1—A	1—A	1—A	1—B	1—B	2—B	2—B	2—B
Belt Pitch (mm)	1049	947	947	947	1011	1011	935	935	960
FAN SPEEDS (r/s)									
Factory Setting	16.0	18.7	18.7	18.7	16.3	17.7	18.6	17.1	17.1
Range	14.0-18.1	16.3-20.0*†	16.3-20.0†	16.3-20.0†	14.4-18.3	15.8-19.5	16.9-20.0†	14.6-17.9	14.6-17.9
Max Allowable Speed (r/s)	20.0	20.0	20.0	20.0	20.0	20.0	20.0	18.3	18.3
Change per 1/2 Turn of Moveable Motor Pulley Flange	0.410	0.478	0.478	0.478	0.323	0.307	0.323	0.278	0.278
MAX FULL TURNS FROM CLOSED POSITION	5	5	5	5	6	6	6	6	6
SHAFTS CENTER DISTANCE (mm)	265-313	265-313	265-313	265-313	265-313**	232-279	207-255	169-240	169-240

*Values for 3-phase motor shown. For single-phase motor, pulley pitch diameter is 178 mm and resulting fan speed is 14.0-18.3 r/s.

†It is possible to adjust drive so that fan speed exceeds maximum allowable. DO NOT exceed 20 r/s.

**575-v unit has a center distance of 233-279.

Table 10A — Standard Drive Data, 50 Hz — English

UNIT	40RM 007	40RM 40RMQ 40RMS 008	40RMS 010	40RM 40RMQ 40RMS 012	40RM 40RMS 014	40RM 40RMQ 40RMS 016	40RM 40RMQ 40RMS 024	40RM 40RMQ 40RMS 028	40RM 40RMS 034
MOTOR DRIVE									
Motor Pulley Pitch Diameter (in.)	2.4-3.4	2.8-3.8	2.8-3.8	3.4-4.4	3.4-4.4	3.4-4.4	4.3-5.3	4.3-5.3	4.3-5.3
Pulley Factory Setting Full Turns Open	2.5	2.5	2.5	2.5	2.5	2.5	3.0	3.0	3.0
FAN DRIVE									
Pulley Pitch Dia (in.)	8.0	8.0	8.0	8.0	9.0	9.0	8.6	11.0	11.0
Pulley Bore (in.)	1	1	1	1	1 ⁷ / ₁₆	1 ⁷ / ₁₆	1 ⁷ / ₁₆	1 ¹⁵ / ₁₆	1 ¹⁵ / ₁₆
Belt No. — Section	1—A	1—A	1—A	1—A	1—A	1—A	1—B	2—B	2—B
Belt Pitch (in.)	39.3	39.3	39.3	40.3	42.3	42.3	41.8	43.8	43.8
FAN SPEEDS (rpm)									
Factory Setting	517	588	588	695	618	618	795	622	622
Range	428-606	499-677	449-677	606-784	538-697	538-697	713-878	557-687	557-687
Max Allowable Speed (rpm)	1200	1200	1200	1200	1200	1200	1200	1100	1100
Change per 1/2 Turn of Moveable Motor Pulley Flange	17.8	17.8	17.8	17.8	15.9	15.9	13.8	10.8	10.8
MAX FULL TURNS FROM CLOSED POSITION	5	5	5	5	5	5	6	6	6
SHAFTS CENTER DISTANCE (in.)	10.44- 12.32	10.44- 12.32	10.44- 12.32	10.44- 12.32	10.44- 12.32	10.44- 12.32	9.12- 10.99	6.67- 9.43	6.67- 9.43

Table 10B — Medium-Static Drive Data, 50 Hz — English

UNIT	40RM 007	40RM 40RMQ 40RMS 008	40RMS 010	40RM 40RMQ 40RMS 012	40RM 40RMS 014	40RM 40RMQ 40RMS 016	40RM 40RMQ 40RMS 024	40RM 40RMQ 40RMS 028	40RM 40RMS 034
MOTOR DRIVE									
Motor Pulley Pitch Diameter (in.)	3.4-4.4	3.4-4.4	3.4-4.4	3.4-4.4	3.4-4.4	3.7-4.7	4.0-5.0	4.3-5.3	4.3-5.3
Pulley Factory Setting Full Turns Open	2.5	2.5	2.5	2.5	2.5	3.0	2.5	3.0	3.0
FAN DRIVE									
Pulley Pitch Dia (in.)	8.0	7.0	7.0	6.0	7.5	7.9	7.0	9.4	9.4
Pulley Bore (in.)	1	1	1	1	1 ⁷ / ₁₆	1 ⁷ / ₁₆	1 ⁷ / ₁₆	1 ¹⁵ / ₁₆	1 ¹⁵ / ₁₆
Belt No. — Section	1—A	1—A	1—A	1—A	1—A	1—B	2—A	2—B	2—B
Belt Pitch (in.)	40.3	41.3	41.3	37.3	39.3	39.8	36.8	39.8	39.8
FAN SPEEDS (rpm)									
Factory Setting	695	794	794	926	741	756	916	728	728
Range	606-784	692-896	692-896	808-1045	646-836	667-848	814-1018	652-803	652-803
Max Allowable Speed (rpm)	1200	1200	1200	1200	1200	1200	1200	1100	1100
Change per 1/2 Turn of Moveable Motor Pulley Flange	17.8	20.4	20.4	23.7	19.0	15.1	20.4	12.6	12.6
MAX FULL TURNS FROM CLOSED POSITION	5	5	5	5	5	6	5	6	6
SHAFTS CENTER DISTANCE (in.)	10.44- 12.32	10.44- 12.32	10.44- 12.32	10.44- 12.32	10.44- 12.32	9.16- 10.99	9.16- 10.99	6.67- 9.43	6.67- 9.43

Table 10C — High-Static Drive Data, 50 Hz — English

UNIT	40RM 007	40RM 40RMQ 40RMS 008	40RMS 010	40RM 40RMQ 40RMS 012	40RM 40RMS 014	40RM 40RMQ 40RMS 016	40RM 40RMQ 40RMS 024	40RM 40RMQ 40RMS 028	40RM 40RMS 034
MOTOR DRIVE									
Motor Pulley Pitch Diameter (in.)	3.4-4.4	3.4-4.4	3.4-4.4	4.0-5.0	3.4-4.4	4.0-5.0	4.0-5.0	4.3-5.3	4.3-5.3
Pulley Factory Setting Full Turns Open	2.5	2.5	2.5	3.0	2.5	3.0	3.0	3.0	3.0
FAN DRIVE									
Pulley Pitch Dia (in.)	6.0	5.5	5.5	5.5	6.0	7.0	6.4	8.0	8.6
Pulley Bore (in.)	1	1	1	1	17/16	17/16	17/16	115/16	115/16
Belt No. — Section	1—A	1—A	1—A	1—A	2—A	2—A	2—A	2—B	2—B
Belt Pitch (in.)	37.3	37.3	37.3	36.3	36.3	39.3	34.3	36.8	37.8
FAN SPEEDS (rpm)									
Factory Setting	926	1010	1010	1166	926	916	1002	855	795
Range	808- 1045	881- 1140	881- 1140	1036- 1200*	808- 1045	814- 1018	891- 1113	766- 944	713- 878
Max Allowable Speed (rpm)	1200	1200	1200	1200	1200	1200	1200	1100	1100
Change per 1/2 Turn of Moveable Motor Pulley Flange	23.7	25.9	25.9	21.6	23.7	17.0	18.5	14.8	13.8
MAX FULL TURNS FROM CLOSED POSITION	5	5	5	6	5	6	6	6	6
SHAFTS CENTER DISTANCE (in.)	10.44- 12.32	10.44- 12.32	10.44- 12.32	9.16- 10.99	9.16- 10.99	9.16- 10.99	8.16- 10.02	6.67- 9.43	6.67- 9.43

*It is possible to adjust drive so that fan speed exceeds maximum allowable. DO NOT exceed 1200 rpm.

Table 10D — Standard Drive Data, 50 Hz — SI

UNIT	40RM 007	40RM 40RMQ 40RMS 008	40RMS 010	40RM 40RMQ 40RMS 012	40RM 40RMS 014	40RM 40RMQ 40RMS 016	40RM 40RMQ 40RMS 024	40RM 40RMQ 40RMS 028	40RM 40RMS 034
MOTOR DRIVE									
Motor Pulley Pitch Diameter (mm)	61.0 86.4	71.1 96.5	71.1- 96.5	86.4- 111.8	86.4- 111.8	86.4- 111.8	109.2 134.6	109.2- 134.6	109.2- 134.6
Pulley Factory Setting Full Turns Open	2.5	2.5	2.5	2.5	2.5	2.5	3.0	3.0	3.0
FAN DRIVE									
Pulley Pitch Dia (mm)	203	203	203	203	229	229	218	279	279
Pulley Bore (mm)	25.4	25.4	25.4	25.4	36.5	36.5	36.5	49.2	49.2
Belt No. — Section	1—A	1—A	1—A	1—A	1—A	1—A	1—B	2—B	2—B
Belt Pitch (mm)	998	998	998	1024	1074	1074	1062	1113	1113
FAN SPEEDS (r/s)									
Factory Setting	8.6	9.8	9.8	11.6	10.3	10.3	13.3	10.4	10.4
Range	7.1-10.1	8.3-11.3	8.3-11.3	10.1-13.1	9.0-11.6	9.0-11.6	11.9-14.6	9.3-11.5	9.3-11.5
Max Allowable Speed (r/s)	20.0	20.0	20.0	20.0	20.0	20.0	20.0	18.3	18.3
Change per 1/2 Turn of Moveable Motor Pulley Flange	0.297	0.297	0.297	0.297	0.265	0.265	0.230	0.180	0.180
MAX FULL TURNS FROM CLOSED POSITION	5	5	5	5	5	5	6	6	6
SHAFTS CENTER DISTANCE (mm)	265-313	265-313	265-313	265-313	265-313	265-313	232-279	169-240	169-240

Table 10E — Medium-Static Drive Data, 50 Hz — SI

UNIT	40RM 007	40RM 40RMQ 40RMS 008	40RMS 010	40RM 40RMQ 40RMS 012	40RM 40RMS 014	40RM 40RMQ 40RMS 016	40RM 40RMQ 40RMS 024	40RM 40RMQ 40RMS 028	40RM 40RMS 034
MOTOR DRIVE									
Motor Pulley Pitch Diameter (mm)	86.4 111.8	86.4- 111.8	86.4- 111.8	86.4- 111.8	86.4- 111.8	94.0- 119.4	101.6- 127.0	109.2- 134.6	109.2 134.6
Pulley Factory Setting Full Turns Open	2.5	2.5	2.5	2.5	2.5	3.0	2.5	3.0	3.0
FAN DRIVE									
Pulley Pitch Dia (mm)	203	178	178	152	191	201	178	239	239
Pulley Bore (mm)	25.4	25.4	25.4	25.4	36.5	36.5	36.5	49.2	49.2
Belt No. — Section	1—A	1—A	1—A	1—A	1—A	1—B	2—A	2—B	2—B
Belt Pitch (mm)	1024	1049	1049	947	998	1011	922	1011	1011
FAN SPEEDS (r/s)									
Factory Setting	11.6	13.2	13.2	15.4	12.4	12.6	15.3	12.1	12.1
Range	10.1-13.1	11.5-14.9	11.5-14.9	13.5-17.4	10.8-13.9	11.1-14.1	13.6-17.0	10.9-13.4	10.9-13.4
Max Allowable Speed (r/s)	20.0	20.0	20.0	20.0	20.0	20.0	20.0	18.3	18.3
Change per 1/2 Turn of Moveable Motor Pulley Flange	0.297	0.340	0.340	0.395	0.317	0.252	0.340	0.210	0.210
MAX FULL TURNS FROM CLOSED POSITION	5	5	5	5	5	6	5	6	6
SHAFTS CENTER DISTANCE (mm)	265-313	265-313	265-313	265-313	265-313	232-279	232-279	169-240	169-240

Table 10F — High-Static Drive Data, 50 Hz — SI

UNIT	40RM 007	40RM 40RMQ 40RMS 008	40RMS 010	40RM 40RMQ 40RMS 012	40RM 40RMS 014	40RM 40RMQ 40RMS 016	40RM 40RMQ 40RMS 024	40RM 40RMQ 40RMS 028	40RM 40RMS 034
MOTOR DRIVE									
Motor Pulley Pitch Diameter (mm)	86.4- 111.8	86.4- 111.8	86.4- 111.8	101.6- 127.0	86.4- 111.8	101.6- 127.0	101.6- 127.0	109.2- 134.6	109.2- 134.6
Pulley Factory Setting Full Turns Open	2.5	2.5	2.5	3.0	2.5	3.0	3.0	3.0	3.0
FAN DRIVE									
Pulley Pitch Dia (mm)	152	140	140	140	152	178	163	203	218
Pulley Bore (mm)	25.4	25.4	25.4	25.4	36.5	36.5	36.5	49.2	49.2
Belt No. — Section	1—A	1—A	1—A	1—A	2—A	2—A	2—A	2—B	2—B
Belt Pitch (mm)	947	947	947	922	922	998	871	935	960
FAN SPEEDS (r/s)									
Factory Setting	15.4	16.8	16.8	19.4	15.4	15.3	16.7	14.3	13.3
Range	13.5-17.4	14.7-19.0	14.7-19.0	17.3-20.0*	13.5-17.4	13.6-17.0	14.9-18.6	12.8-15.7	11.9-14.6
Max Allowable Speed (r/s)	20.0	20.0	20.0	20.0	20.0	20.0	20.0	18.3	18.3
Change per 1/2 Turn of Moveable Motor Pulley Flange	0.395	0.432	0.432	0.360	0.395	0.283	0.308	0.247	0.230
MAX FULL TURNS FROM CLOSED POSITION	5	5	5	6	5	6	6	6	6
SHAFTS CENTER DISTANCE (mm)	265-313	265-313	265-313	234-279	232-279	232-279	207-255	169-240	169-240

*It is possible to adjust drive so that fan speed exceeds maximum allowable. DO NOT exceed 20 r/s.

**Table 11A — 40RM,RMQ Standard Fan Performance Data —
0.0-2.4 in. wg External Static Pressure — English**

UNIT 40RM, RMQ	AIRFLOW (Cfm)	EXTERNAL STATIC PRESSURE (in. wg)													
		0.0		0.2		0.4		0.6		0.8		1.0		1.2	
		Rpm	Bhp	Rpm	Bhp	Rpm	Bhp	Rpm	Bhp	Rpm	Bhp	Rpm	Bhp	Rpm	Bhp
007	1,800	399	0.19	454	0.24	548	0.35	634	0.47	713	0.60	785	0.74	850	0.89
	2,100	446	0.28	497	0.34	583	0.46	660	0.59	733	0.73	802	0.88	867	1.05
	2,400	498	0.40	541	0.47	622	0.60	693	0.74	760	0.89	824	1.05	885	1.22
	2,700	544	0.55	588	0.63	663	0.78	730	0.93	792	1.09	851	1.26	909	1.44
	3,000	594	0.73	635	0.82	707	0.99	770	1.15	828	1.32	883	1.50	937	1.69
008	2,250	273	0.08	493	0.37	580	0.49	656	0.62	727	0.76	794	0.92	858	1.08
	2,600	322	0.15	540	0.52	622	0.66	693	0.81	757	0.96	819	1.12	878	1.29
	3,000	552	0.65	595	0.73	673	0.91	740	1.07	800	1.24	856	1.41	910	1.60
	3,400	615	0.91	653	1.01	726	1.21	789	1.40	846	1.59	899	1.78	950	1.97
	3,750	671	1.20	706	1.31	773	1.53	834	1.74	889	1.95	940	2.16	988	2.37
012	3,000	399	0.29	573	0.69	654	0.86	722	1.03	784	1.19	841	1.37	896	1.55
	3,500	604	0.92	641	1.02	714	1.22	780	1.42	838	1.61	892	1.81	942	2.01
	4,000	680	1.33	713	1.45	778	1.68	839	1.91	896	2.14	947	2.36	995	2.58
	4,500	756	1.86	787	1.99	845	2.26	901	2.52	955	2.78	1005	3.03	1051	3.28
	5,000	834	2.51	861	2.67	914	2.96	966	3.25	1016	3.54	1064	3.82	1109	4.11
014	3,750	394	0.40	453	0.52	558	0.80	643	1.10	717	1.39	785	1.71	848	2.04
	4,300	436	0.57	487	0.70	586	1.00	670	1.34	742	1.67	806	2.01	867	2.36
	5,000	492	0.86	535	0.99	623	1.31	704	1.69	775	2.08	838	2.47	896	2.86
	5,700	550	1.23	587	1.37	664	1.71	740	2.11	809	2.55	872	2.99	929	3.43
	6,250	596	1.59	630	1.74	700	2.09	770	2.51	837	2.97	899	3.45	955	3.94
016	4,500	428	0.59	475	0.70	570	0.99	656	1.33	730	1.68	796	2.02	856	2.38
	5,300	488	0.92	528	1.04	609	1.34	689	1.71	762	2.11	827	2.51	886	2.92
	6,000	542	1.29	578	1.43	649	1.74	721	2.11	791	2.55	855	3.00	914	3.46
	6,800	604	1.83	637	1.99	700	2.32	763	2.70	826	3.15	888	3.64	946	4.15
	7,500	660	2.42	690	2.59	747	2.95	804	3.34	861	3.79	919	4.29	975	4.83
024	6,000	532	1.25	569	1.39	639	1.69	711	2.06	781	2.48	846	2.93	905	3.39
	7,000	608	1.93	641	2.09	702	2.42	763	2.80	824	3.23	885	3.71	943	4.23
	8,000	686	2.83	716	3.01	770	3.38	823	3.77	876	4.21	930	4.70	983	5.24
	9,000	764	3.97	791	4.18	841	4.59	888	5.02	935	5.47	982	5.96	1030	6.51
	10,000	843	5.38	868	5.62	914	6.09	957	6.55	1000	7.02	1042	7.53	1084	8.08
028	7,500	456	1.29	490	1.47	556	1.85	621	2.25	678	2.64	729	3.06	778	3.60
	8,750	521	1.98	551	2.18	608	2.61	664	3.07	720	3.53	770	3.99	816	4.45
	10,000	587	2.88	614	3.11	664	3.59	714	4.09	763	4.62	812	5.15	857	5.68
	11,250	653	4.03	678	4.29	724	4.82	768	5.37	812	5.95	856	6.54	899	7.14
	12,500	720	5.46	743	5.75	785	6.33	825	6.93	865	7.55	904	8.20	944	8.86
15,000	829	8.84	850	9.19	888	9.88	924	10.57	958	11.27	991	11.99	1024	12.73	
034	9,000	521	1.99	550	2.25	616	2.77	676	3.23	731	3.72	782	4.20	829	4.70
	10,500	596	3.16	623	3.40	672	3.89	720	4.40	767	4.94	814	5.50	859	6.05
	12,000	673	4.63	698	4.90	743	5.45	785	6.02	826	6.62	867	7.23	908	7.87
	13,500	751	6.51	773	6.82	815	7.44	853	8.06	890	8.71	927	9.38	963	10.07
	15,000	829	8.84	850	9.19	888	9.88	924	10.57	958	11.27	991	11.99	1024	12.73

See Legend and Notes on page 45.

**Table 11A — 40RM,RMQ Standard Fan Performance Data —
0.0-2.4 in. wg External Static Pressure — English (cont)**

UNIT 40RM, RMQ	AIRFLOW (Cfm)	EXTERNAL STATIC PRESSURE (in. wg)											
		1.4		1.6		1.8		2.0		2.2		2.4	
		Rpm	Bhp	Rpm	Bhp	Rpm	Bhp	Rpm	Bhp	Rpm	Bhp	Rpm	Bhp
007	1,800	910	1.04	965	1.20	1016	1.36	1065	1.52	1111	1.69	1155	1.86
	2,100	927	1.21	983	1.38	1035	1.56	1084	1.74	1131	1.92	1175	2.11
	2,400	944	1.41	999	1.59	1052	1.78	1101	1.98	1149	2.18	1193	2.38
	2,700	964	1.63	1018	1.82	1069	2.03	1118	2.24	1165	2.45	—	—
	3,000	989	1.89	1039	2.10	1089	2.31	1136	2.53	1183	2.76	—	—
008	2,250	918	1.26	975	1.43	1029	1.62	1079	1.80	1126	1.99	1172	2.18
	2,600	936	1.48	991	1.67	1044	1.87	1094	2.07	1142	2.28	1188	2.49
	3,000	963	1.79	1014	1.99	1064	2.20	1113	2.42	1159	2.64	—	—
	3,400	998	2.18	1045	2.39	1092	2.61	1137	2.83	1182	3.07	—	—
	3,750	1034	2.58	1078	2.80	1122	3.03	1164	3.27	—	—	—	—
012	3,000	949	1.74	1000	1.93	1050	2.14	1099	2.36	1147	2.58	1192	2.81
	3,500	990	2.21	1037	2.42	1083	2.64	1128	2.86	1172	3.10	—	—
	4,000	1040	2.80	1084	3.03	1126	3.26	1167	3.50	—	—	—	—
	4,500	1094	3.53	1136	3.78	1176	4.03	—	—	—	—	—	—
	5,000	1151	4.39	1191	4.66	—	—	—	—	—	—	—	—
014	3,750	909	2.37	968	2.74	1026	3.12	1080	3.51	1131	3.92	1181	4.32
	4,300	925	2.73	980	3.11	1034	3.52	1084	3.92	1135	4.35	1184	4.78
	5,000	950	3.26	1002	3.67	1052	4.09	1101	4.53	1148	4.98	1190	5.44
	5,700	981	3.88	1031	4.33	1079	4.79	1125	5.25	1169	5.73	—	—
	6,250	1007	4.42	1057	4.91	1103	5.40	1148	5.90	1191	6.40	—	—
016	4,500	912	2.75	967	3.13	1019	3.52	1070	3.92	1120	4.35	1168	4.79
	5,300	940	3.33	992	3.75	1041	4.18	1088	4.61	1134	5.06	1179	5.52
	6,000	968	3.92	1018	4.38	1066	4.85	1112	5.32	1156	5.80	1198	6.29
	6,800	1000	4.67	1050	5.19	1097	5.71	1142	6.23	1185	6.76	—	—
	7,500	1028	5.39	1078	5.97	1125	6.54	1170	7.11	—	—	—	—
024	6,000	954	3.83	1005	4.27	1052	4.72	1098	5.22	1142	5.67	—	—
	7,000	990	4.74	1040	5.24	1090	5.80	1135	6.30	1176	6.84	—	—
	8,000	1028	5.79	1078	6.38	1130	7.00	1173	7.60	—	—	—	—
	9,000	1073	7.11	1120	7.72	1169	8.37	—	—	—	—	—	—
	10,000	1126	8.75	1166	9.37	—	—	—	—	—	—	—	—
028	7,500	831	4.41	870	5.10	913	5.90	950	6.88	985	7.70	—	—
	8,750	859	4.97	901	5.59	944	6.42	980	7.20	1020	8.10	—	—
	10,000	900	6.20	939	6.74	976	7.33	1013	8.00	1050	8.82	—	—
	11,250	941	7.73	980	8.32	1017	8.90	1052	9.51	1086	10.16	—	—
	12,500	984	9.53	1022	10.19	1058	10.84	1093	11.49	—	—	—	—
15,000	1057	13.49	1090	14.28	—	—	—	—	—	—	—	—	
034	9,000	866	5.20	899	5.85	950	6.65	989	7.38	1029	8.32	1077	9.74
	10,500	902	6.60	942	7.14	980	7.70	1016	8.31	1051	8.99	1085	9.77
	12,000	949	8.50	988	9.14	1026	9.76	1062	10.38	1095	11.01	—	—
	13,500	1000	10.78	1036	11.49	1073	12.21	—	—	—	—	—	—
	15,000	1057	13.49	1090	14.28	—	—	—	—	—	—	—	—

See Legend and Notes on page 45.

**Table 11B — 40RM,RMQ Standard Fan Performance Data —
0-600 kPa External Static Pressure — SI**

UNIT 40RM, RMQ	AIRFLOW (L/s)	EXTERNAL STATIC PRESSURE (kPa)													
		0		50		100		150		200		250		300	
		r/s	kW	r/s	kW	r/s	kW	r/s	kW	r/s	kW	r/s	kW	r/s	kW
007	850	6.64	0.14	7.56	0.18	9.13	0.26	10.56	0.35	11.88	0.45	13.08	0.55	14.16	0.66
	990	7.73	0.21	8.28	0.25	9.71	0.34	11.00	0.44	12.22	0.54	13.37	0.66	14.44	0.78
	1130	8.30	0.30	9.02	0.35	10.36	0.45	11.55	0.55	12.67	0.66	13.73	0.78	14.76	0.91
	1270	9.06	0.41	9.79	0.47	11.06	0.58	12.17	0.69	13.20	0.81	14.19	0.94	15.14	1.07
	1420	9.91	0.55	10.58	0.61	11.78	0.74	12.83	0.86	13.80	0.99	14.72	1.12	15.61	1.26
008	1060	4.55	0.06	8.21	0.27	9.67	0.37	10.93	0.46	12.11	0.57	13.23	0.68	14.30	0.81
	1230	5.37	0.11	8.99	0.38	10.37	0.49	11.55	0.60	12.62	0.71	13.65	0.84	14.64	0.96
	1420	9.21	0.48	9.92	0.55	11.22	0.67	12.33	0.80	13.33	0.92	14.27	1.05	15.17	1.19
	1600	10.25	0.68	10.89	0.75	12.09	0.90	13.15	1.04	14.10	1.18	14.99	1.33	15.83	1.47
	1770	11.18	0.90	11.76	0.98	12.88	1.14	13.90	1.30	14.82	1.45	15.67	1.61	16.46	1.77
012	1420	6.65	0.22	9.55	0.51	10.89	0.64	12.04	0.77	13.06	0.89	14.02	1.02	14.93	1.15
	1650	10.06	0.68	10.69	0.76	11.90	0.91	13.00	1.06	13.97	1.20	14.86	1.35	15.70	1.50
	1890	11.33	0.99	11.88	1.08	12.96	1.25	13.99	1.43	14.93	1.59	15.78	1.76	16.58	1.92
	2120	12.61	1.38	13.11	1.49	14.08	1.68	15.02	1.88	15.92	2.07	16.74	2.26	17.51	2.44
	2360	13.90	1.87	14.36	1.99	15.23	2.21	16.10	2.42	16.94	2.64	17.73	2.85	18.48	3.06
014	1770	6.57	0.30	7.54	0.39	9.31	0.60	10.72	0.82	11.95	1.04	13.09	1.27	14.13	1.52
	2030	7.27	0.43	8.11	0.52	9.76	0.75	11.16	1.00	12.36	1.25	13.44	1.50	14.45	1.76
	2360	8.20	0.64	8.92	0.74	10.38	0.98	11.73	1.26	12.91	1.55	13.97	1.84	14.93	2.13
	2690	9.16	0.92	9.79	1.02	11.07	1.27	12.33	1.58	13.48	1.90	14.53	2.23	15.48	2.56
	2950	9.93	1.18	10.50	1.30	11.66	1.56	12.83	1.87	13.95	2.22	14.98	2.58	15.92	2.94
016	2120	7.13	0.44	7.91	0.52	9.50	0.74	10.94	0.99	12.17	1.25	13.26	1.51	14.26	1.77
	2500	8.13	0.68	8.80	0.78	10.15	1.00	11.48	1.27	12.70	1.57	13.78	1.87	14.76	2.18
	2830	9.03	0.96	9.63	1.07	10.81	1.30	12.01	1.58	13.18	1.90	14.25	2.24	15.23	2.58
	3210	10.07	1.37	10.62	1.48	11.66	1.73	12.71	2.01	13.77	2.35	14.80	2.71	15.76	3.09
	3540	10.99	1.81	11.50	1.93	12.45	2.20	13.40	2.49	14.35	2.83	15.31	3.20	16.24	3.60
024	2830	8.86	0.94	9.48	1.04	10.65	1.26	11.84	1.53	13.01	1.85	14.10	2.19	15.08	2.53
	3300	10.14	1.44	10.69	1.56	11.70	1.81	12.71	2.08	13.73	2.41	14.74	2.77	15.71	3.15
	3780	11.43	2.11	11.93	2.25	12.84	2.52	13.71	2.81	14.60	3.14	15.49	3.51	16.39	3.91
	4250	12.74	2.96	13.19	3.12	14.02	3.43	14.81	3.74	15.59	4.08	16.37	4.45	17.17	4.85
	4720	14.05	4.01	14.47	4.19	15.23	4.54	15.96	4.88	16.66	5.24	17.36	5.62	18.07	6.03
028	3540	7.60	0.96	8.16	1.09	9.27	1.38	10.34	1.68	11.30	1.97	12.15	2.28	12.97	2.68
	4130	8.68	1.47	9.18	1.62	10.13	1.94	11.07	2.29	11.99	2.63	12.84	2.97	13.60	3.32
	4720	9.78	2.15	10.23	2.32	11.07	2.67	11.89	3.05	12.72	3.45	13.53	3.84	14.29	4.23
	5310	10.89	3.01	11.30	3.20	12.06	3.59	12.80	4.00	13.53	4.43	14.27	4.88	14.99	5.33
	5900	12.00	4.07	12.38	4.29	13.09	4.72	13.75	5.17	14.41	5.63	15.07	6.11	15.74	6.61
034	4250	8.68	1.48	9.17	1.68	10.27	2.07	11.27	2.41	12.19	2.77	13.03	3.13	13.81	3.50
	4960	9.93	2.35	10.38	2.53	11.21	2.90	11.99	3.28	12.78	3.68	13.56	4.10	14.32	4.51
	5660	11.21	3.45	11.63	3.66	12.38	4.07	13.08	4.49	13.76	4.93	14.45	5.39	15.14	5.87
	6370	12.51	4.85	12.89	5.08	13.58	5.54	14.22	6.01	14.83	6.49	15.44	6.99	16.05	7.51
	7080	13.82	6.59	14.17	6.85	14.81	7.36	15.40	7.88	15.97	8.40	16.52	8.94	17.06	9.49

See Legend and Notes on page 45.

**Table 11B — 40RM,RMQ Standard Fan Performance Data —
0-600 kPa External Static Pressure — SI (cont)**

UNIT 40RM, RMQ	AIRFLOW (L/s)	EXTERNAL STATIC PRESSURE (kPa)											
		350		400		450		500		550		600	
		r/s	kW	r/s	kW	r/s	kW	r/s	kW	r/s	kW	r/s	kW
007	850	15.16	0.78	16.08	0.89	16.94	1.01	17.74	1.13	18.51	1.26	19.25	1.39
	990	15.44	0.90	16.38	1.03	17.25	1.16	18.07	1.30	18.84	1.43	19.58	1.57
	1130	15.73	1.05	16.65	1.19	17.53	1.33	18.36	1.48	19.14	1.62	19.89	1.77
	1270	16.07	1.21	16.96	1.36	17.82	1.51	18.64	1.67	19.42	1.83	—	—
	1420	16.48	1.41	17.32	1.56	18.14	1.72	18.94	1.89	19.71	2.06	—	—
008	1060	15.31	0.94	16.25	1.07	17.14	1.20	17.98	1.34	18.77	1.48	19.53	1.63
	1230	15.60	1.10	16.51	1.24	17.39	1.39	18.23	1.54	19.03	1.70	19.80	1.86
	1420	16.05	1.33	16.90	1.48	17.74	1.64	18.54	1.80	19.32	1.97	—	—
	1600	16.64	1.62	17.42	1.78	18.20	1.94	18.95	2.11	19.69	2.29	—	—
	1770	17.23	1.93	17.97	2.09	18.70	2.26	19.41	2.44	—	—	—	—
012	1420	15.81	1.29	16.67	1.44	17.51	1.60	18.32	1.76	19.11	1.92	19.87	2.09
	1650	16.51	1.65	17.29	1.80	18.05	1.97	18.80	2.13	19.53	2.31	—	—
	1890	17.34	2.09	18.06	2.26	18.77	2.43	19.45	2.61	—	—	—	—
	2120	18.24	2.63	18.93	2.82	19.59	3.00	—	—	—	—	—	—
	2360	19.18	3.27	19.85	3.48	—	—	—	—	—	—	—	—
014	1770	15.15	1.77	16.13	2.04	17.10	2.33	18.00	2.62	18.85	2.92	19.68	3.22
	2030	15.41	2.04	16.34	2.32	17.24	2.62	18.07	2.92	18.92	3.24	19.73	3.56
	2360	15.84	2.43	16.70	2.74	17.54	3.05	18.35	3.38	19.14	3.71	19.83	4.06
	2690	16.36	2.89	17.19	3.23	17.98	3.57	18.75	3.92	19.49	4.27	—	—
	2950	16.79	3.30	17.61	3.66	18.39	4.03	19.13	4.40	19.84	4.77	—	—
016	2120	15.20	2.05	16.12	2.33	16.98	2.62	17.83	2.92	18.67	3.24	19.47	3.57
	2500	15.67	2.49	16.53	2.80	17.35	3.12	18.13	3.44	18.90	3.77	19.65	4.12
	2830	16.13	2.92	16.97	3.27	17.77	3.62	18.53	3.97	19.26	4.33	19.97	4.69
	3210	16.66	3.48	17.50	3.87	18.29	4.26	19.03	4.65	19.75	5.04	—	—
	3540	17.13	4.02	17.97	4.45	18.75	4.88	19.50	5.30	—	—	—	—
024	2830	15.90	2.86	16.75	3.18	17.53	3.52	18.30	3.89	19.03	4.23	—	—
	3300	16.50	3.53	17.33	3.91	18.17	4.32	18.92	4.70	19.60	5.10	—	—
	3780	17.13	4.32	17.97	4.76	18.83	5.22	19.55	5.67	—	—	—	—
	4250	17.88	5.30	18.67	5.76	19.48	6.24	—	—	—	—	—	—
	4720	18.77	6.52	19.43	6.99	—	—	—	—	—	—	—	—
028	3540	13.85	3.29	14.50	3.80	15.22	4.40	15.83	5.13	16.42	5.74	—	—
	4130	14.31	3.71	15.01	4.17	15.74	4.79	16.33	5.37	17.00	6.04	—	—
	4720	14.99	4.62	15.65	5.02	16.27	5.46	16.88	5.97	17.50	6.57	—	—
	5310	15.68	5.77	16.34	6.20	16.95	6.64	17.53	7.09	18.09	7.58	—	—
	5900	16.39	7.10	17.03	7.60	17.64	8.08	18.22	8.57	—	—	—	—
034	4250	14.43	3.88	14.98	4.36	15.84	4.96	16.48	5.50	17.16	6.21	17.96	7.26
	4960	15.04	4.92	15.71	5.32	16.33	5.74	16.93	6.20	17.51	6.70	18.09	7.29
	5660	15.81	6.34	16.47	6.81	17.10	7.28	17.69	7.74	18.26	8.21	—	—
	6370	16.66	8.04	17.27	8.57	17.88	9.10	—	—	—	—	—	—
	7080	17.61	10.06	18.16	10.64	—	—	—	—	—	—	—	—

See Legend and Notes on page 45.

**Table 11C — 40RM High-Capacity Fan Performance Data —
0.0-2.4 in. wg External Static Pressure — English**

UNIT 40RM	AIRFLOW (Cfm)	EXTERNAL STATIC PRESSURE (in. wg)													
		0.0		0.2		0.4		0.6		0.8		1.0		1.2	
		Rpm	Bhp	Rpm	Bhp	Rpm	Bhp	Rpm	Bhp	Rpm	Bhp	Rpm	Bhp	Rpm	Bhp
007	1,800	419	0.21	471	0.26	564	0.37	649	0.49	727	0.63	797	0.77	862	0.92
	2,100	471	0.31	519	0.37	602	0.49	679	0.62	751	0.77	819	0.92	882	1.09
	2,400	524	0.44	568	0.51	645	0.64	715	0.79	781	0.94	844	1.11	905	1.28
	2,700	578	0.61	619	0.69	690	0.84	755	0.99	816	1.15	875	1.33	932	1.51
	3,000	633	0.81	671	0.90	738	1.07	799	1.24	856	1.41	910	1.60	963	1.79
008	2,250	290	0.10	510	0.39	594	0.51	669	0.65	739	0.79	806	0.95	870	1.12
	2,600	349	0.19	561	0.55	640	0.70	709	0.84	773	1.00	834	1.16	893	1.34
	3,000	579	0.70	621	0.79	695	0.96	759	1.12	818	1.30	874	1.47	928	1.66
	3,400	646	0.99	683	1.09	752	1.29	813	1.48	869	1.67	920	1.86	970	2.06
	3,750	705	1.31	739	1.42	804	1.63	862	1.85	915	2.05	964	2.26	1011	2.48
012	3,000	421	0.35	592	0.73	670	0.90	737	1.06	797	1.23	854	1.41	908	1.59
	3,500	626	0.98	664	1.08	735	1.28	798	1.48	855	1.67	908	1.87	958	2.07
	4,000	706	1.42	738	1.54	803	1.77	862	2.00	917	2.23	967	2.45	1014	2.67
	4,500	786	1.99	815	2.12	873	2.39	929	2.65	980	2.90	1028	3.16	1073	3.41
	5,000	867	2.70	893	2.84	946	3.14	997	3.43	1046	3.72	1092	4.00	1135	4.28
014	3,750	410	0.43	467	0.55	567	0.83	649	1.12	721	1.41	788	1.72	851	2.05
	4,300	455	0.62	504	0.74	599	1.05	679	1.38	748	1.70	811	2.04	871	2.39
	5,000	514	0.92	556	1.06	641	1.39	718	1.76	786	2.14	847	2.52	903	2.91
	5,700	575	1.32	612	1.47	686	1.82	759	2.23	825	2.66	884	3.09	939	3.52
	6,250	624	1.71	657	1.87	725	2.24	793	2.66	856	3.12	915	3.59	969	4.06
016	4,500	437	0.61	483	0.72	576	1.01	660	1.35	732	1.69	797	2.03	856	2.38
	5,300	499	0.95	538	1.07	617	1.37	696	1.74	767	2.13	830	2.53	888	2.94
	6,000	555	1.34	590	1.48	659	1.79	730	2.17	798	2.59	860	3.04	918	3.49
	6,800	620	1.91	651	2.06	712	2.39	774	2.78	836	3.22	896	3.71	952	4.21
	7,500	677	2.52	706	2.69	761	3.04	817	3.44	873	3.89	929	4.39	984	4.93
024	6,000	542	1.29	577	1.42	646	1.72	716	2.09	785	2.51	849	2.95	907	3.40
	7,000	620	1.99	652	2.15	711	2.48	771	2.85	831	3.28	890	3.76	947	4.27
	8,000	700	2.92	728	3.10	781	3.46	833	3.85	885	4.29	938	4.78	990	5.32
	9,000	781	4.10	806	4.30	854	4.71	900	5.13	946	5.58	993	6.08	1039	6.62
	10,000	862	5.56	885	5.79	929	6.24	971	6.70	1012	7.18	1054	7.69	1096	8.24
028	7,500	476	1.39	510	1.58	579	1.99	644	2.40	701	2.81	752	3.29	804	3.96
	8,750	545	2.14	574	2.35	633	2.81	691	3.29	747	3.77	797	4.25	842	4.76
	10,000	615	3.12	641	3.36	692	3.87	743	4.41	794	4.96	843	5.51	888	6.05
	11,250	685	4.37	709	4.64	754	5.20	800	5.79	845	6.40	891	7.02	935	7.64
	12,500	756	5.92	778	6.22	819	6.83	860	7.47	901	8.14	942	8.83	983	9.52
034	9,000	539	2.18	569	2.39	626	2.85	683	3.34	739	3.83	791	4.32	837	4.82
	10,500	620	3.37	646	3.62	695	4.13	744	4.68	793	5.25	842	5.83	888	6.41
	12,000	701	4.94	724	5.22	769	5.80	811	6.40	854	7.04	897	7.69	940	8.36
	13,500	783	6.95	804	7.27	844	7.91	883	8.57	920	9.26	958	9.97	996	10.71
	15,000	865	9.45	884	9.81	921	10.52	956	11.24	991	11.98	1025	12.75	1059	13.54

See Legend and Notes on page 45.

**Table 11C — 40RM High-Capacity Fan Performance Data —
0.0-2.4 in. wg External Static Pressure — English (cont)**

UNIT 40RM	AIRFLOW (Cfm)	EXTERNAL STATIC PRESSURE (in. wg)											
		1.4		1.6		1.8		2.0		2.2		2.4	
		Rpm	Bhp	Rpm	Bhp	Rpm	Bhp	Rpm	Bhp	Rpm	Bhp	Rpm	Bhp
007	1,800	921	1.07	975	1.23	1026	1.39	1074	1.55	1120	1.72	1164	1.90
	2,100	942	1.26	997	1.43	1048	1.61	1097	1.79	1143	1.97	1186	2.16
	2,400	963	1.47	1017	1.66	1069	1.85	1118	2.05	1164	2.25	—	—
	2,700	987	1.71	1039	1.91	1090	2.12	1138	2.33	1185	2.55	—	—
	3,000	1015	1.99	1065	2.20	1113	2.42	1161	2.65	—	—	—	—
008	2,250	930	1.29	986	1.47	1039	1.65	1089	1.84	1136	2.03	1181	2.22
	2,600	950	1.53	1005	1.72	1057	1.92	1107	2.13	1154	2.33	—	—
	3,000	980	1.86	1031	2.06	1081	2.27	1129	2.49	1175	2.72	—	—
	3,400	1018	2.26	1065	2.48	1111	2.70	1156	2.93	—	—	—	—
	3,750	1057	2.69	1101	2.92	1144	3.15	1186	3.39	—	—	—	—
012	3,000	961	1.78	1012	1.98	1062	2.19	1111	2.41	1158	2.64	—	—
	3,500	1005	2.27	1052	2.49	1098	2.71	1142	2.94	1186	3.18	—	—
	4,000	1058	2.90	1101	3.13	1143	3.36	1184	3.60	—	—	—	—
	4,500	1116	3.66	1157	3.91	1196	4.16	—	—	—	—	—	—
	5,000	1176	4.56	—	—	—	—	—	—	—	—	—	—
014	3,750	912	2.39	971	2.76	1028	3.14	1083	3.54	1135	3.95	1185	4.36
	4,300	928	2.75	982	3.13	1036	3.53	1087	3.94	1138	4.37	1187	4.81
	5,000	956	3.30	1007	3.71	1056	4.13	1104	4.56	1151	5.00	1196	5.46
	5,700	990	3.96	1039	4.40	1086	4.85	1130	5.31	1174	5.78	—	—
	6,250	1019	4.54	1067	5.02	1112	5.50	1156	5.99	1198	6.49	—	—
016	4,500	912	2.75	967	3.12	1019	3.52	1070	3.92	1120	4.35	1168	4.79
	5,300	942	3.34	992	3.76	1041	4.18	1088	4.61	1134	5.06	1179	5.52
	6,000	971	3.95	1020	4.40	1067	4.86	1112	5.33	1156	5.81	1198	6.29
	6,800	1005	4.72	1054	5.23	1101	5.75	1145	6.27	1187	6.79	—	—
	7,500	1036	5.48	1084	6.04	1131	6.61	1174	7.17	—	—	—	—
024	6,000	961	3.86	1011	4.31	1058	4.77	1104	5.24	1147	5.71	—	—
	7,000	1000	4.79	1050	5.32	1097	5.85	1142	6.38	1184	6.91	—	—
	8,000	1041	5.88	1090	6.47	1137	7.07	1181	7.67	—	—	—	—
	9,000	1086	7.21	1133	7.82	1178	8.47	—	—	—	—	—	—
	10,000	1138	8.83	1180	9.46	—	—	—	—	—	—	—	—
028	7,500	874	5.33	897	5.91	940	6.80	990	7.50	—	—	—	—
	8,750	886	5.36	930	6.13	982	7.32	1020	8.10	—	—	—	—
	10,000	930	6.60	969	7.20	1007	7.89	1045	8.71	—	—	—	—
	11,250	976	8.25	1014	8.86	1051	9.49	1086	10.17	—	—	—	—
	12,500	1023	10.20	1061	10.88	1097	11.56	—	—	—	—	—	—
034	9,000	881	5.37	923	6.03	967	6.89	1020	8.25	—	—	—	—
	10,500	930	6.97	970	7.55	1008	8.17	1045	8.86	—	—	—	—
	12,000	981	9.02	1021	9.67	1058	10.32	1094	10.97	—	—	—	—
	13,500	1035	11.45	1072	12.20	—	—	—	—	—	—	—	—
	15,000	1093	14.35	—	—	—	—	—	—	—	—	—	—

See Legend and Notes on page 45.

**Table 11D — 40RM High-Capacity Fan Performance Data —
0-600 kPa External Static Pressure — SI**

UNIT 40RM	AIRFLOW (L/s)	EXTERNAL STATIC PRESSURE (kPa)													
		0		50		100		150		200		250		300	
		r/s	kW	r/s	kW	r/s	kW	r/s	kW	r/s	kW	r/s	kW	r/s	kW
007	850	6.98	0.16	7.86	0.19	9.40	0.27	10.81	0.37	12.11	0.47	13.29	0.57	14.36	0.69
	990	7.84	0.23	8.64	0.27	10.03	0.36	11.31	0.46	12.52	0.57	13.65	0.69	14.71	0.81
	1130	8.73	0.33	9.46	0.38	10.75	0.48	11.91	0.59	13.01	0.70	14.07	0.83	15.08	0.96
	1270	9.63	0.45	10.31	0.51	11.51	0.62	12.58	0.74	13.60	0.86	14.58	0.99	15.53	1.13
	1420	10.55	0.61	11.18	0.67	12.30	0.80	13.31	0.92	14.26	1.05	15.17	1.19	16.05	1.33
008	1060	4.83	0.07	8.50	0.29	9.91	0.38	11.15	0.48	12.32	0.59	13.44	0.71	14.50	0.83
	1230	5.81	0.14	9.35	0.41	10.67	0.52	11.81	0.63	12.88	0.74	13.90	0.87	14.89	1.00
	1420	9.65	0.52	10.35	0.59	11.59	0.71	12.66	0.84	13.64	0.97	14.57	1.10	15.47	1.24
	1600	10.76	0.74	11.39	0.81	12.54	0.96	13.55	1.10	14.48	1.24	15.34	1.39	16.17	1.53
	1770	11.74	0.97	12.32	1.06	13.40	1.22	14.37	1.38	15.25	1.53	16.07	1.69	16.86	1.85
012	1420	7.02	0.26	9.86	0.54	11.17	0.67	12.28	0.79	13.29	0.92	14.23	1.05	15.14	1.19
	1650	10.44	0.73	11.06	0.80	12.25	0.96	13.31	1.10	14.25	1.25	15.13	1.39	15.96	1.54
	1890	11.76	1.06	12.31	1.15	13.38	1.32	14.37	1.49	15.28	1.66	16.11	1.83	16.89	1.99
	2120	13.10	1.48	13.59	1.58	14.55	1.78	15.48	1.97	16.34	2.17	17.14	2.35	17.89	2.54
	2360	14.45	2.01	14.89	2.12	15.76	2.34	16.62	2.56	17.43	2.77	18.20	2.98	18.92	3.19
014	1770	6.84	0.32	7.78	0.41	9.46	0.62	10.82	0.83	12.02	1.05	13.13	1.28	14.19	1.53
	2030	7.58	0.46	8.40	0.55	9.98	0.78	11.31	1.03	12.47	1.27	13.52	1.52	14.51	1.78
	2360	8.57	0.69	9.27	0.79	10.68	1.04	11.96	1.31	13.09	1.60	14.11	1.88	15.05	2.17
	2690	9.59	0.99	10.20	1.10	11.44	1.36	12.64	1.66	13.74	1.98	14.74	2.30	15.65	2.63
	2950	10.40	1.28	10.96	1.39	12.09	1.67	13.21	1.98	14.27	2.33	15.25	2.68	16.15	3.03
016	2120	7.28	0.45	8.05	0.54	9.60	0.75	11.00	1.00	12.21	1.26	13.28	1.51	14.27	1.78
	2500	8.32	0.71	8.97	0.80	10.29	1.02	11.59	1.30	12.78	1.59	13.84	1.89	14.80	2.19
	2830	9.25	1.00	9.83	1.10	10.99	1.33	12.16	1.62	13.29	1.93	14.34	2.27	15.30	2.60
	3210	10.33	1.42	10.85	1.54	11.87	1.78	12.90	2.07	13.93	2.40	14.93	2.76	15.87	3.14
	3540	11.29	1.88	11.77	2.01	12.69	2.27	13.62	2.56	14.56	2.90	15.49	3.27	16.40	3.67
024	2830	9.03	0.96	9.62	1.06	10.77	1.29	11.94	1.56	13.08	1.87	14.15	2.20	15.12	2.54
	3300	10.34	1.48	10.86	1.60	11.85	1.85	12.84	2.12	13.85	2.45	14.84	2.80	15.78	3.18
	3780	11.67	2.17	12.14	2.31	13.02	2.58	13.88	2.87	14.75	3.20	15.63	3.56	16.50	3.96
	4250	13.01	3.05	13.44	3.21	14.23	3.51	15.00	3.82	15.77	4.16	16.54	4.53	17.32	4.94
	4720	14.36	4.15	14.75	4.32	15.48	4.66	16.18	4.99	16.87	5.35	17.56	5.73	18.26	6.14
028	3540	7.94	1.04	8.51	1.18	9.65	1.48	10.73	1.79	11.68	2.10	12.53	2.46	13.40	2.95
	4130	9.08	1.59	9.57	1.75	10.55	2.10	11.52	2.46	12.45	2.81	13.28	3.17	14.04	3.55
	4720	10.24	2.33	10.68	2.51	11.53	2.88	12.39	3.29	13.24	3.70	14.05	4.11	14.80	4.51
	5310	11.42	3.26	11.81	3.46	12.57	3.88	13.33	4.32	14.09	4.77	14.85	5.24	15.58	5.70
	5900	12.60	4.42	12.96	4.64	13.65	5.09	14.33	5.57	15.01	6.07	15.70	6.58	16.38	7.10
034	4250	8.99	1.62	9.49	1.78	10.44	2.12	11.39	2.49	12.32	2.86	13.18	3.22	13.95	3.59
	4960	10.33	2.51	10.77	2.70	11.59	3.08	12.40	3.49	13.22	3.92	14.03	4.35	14.79	4.78
	5660	11.68	3.68	12.07	3.90	12.81	4.33	13.52	4.77	14.23	5.25	14.95	5.74	15.66	6.23
	6370	13.04	5.18	13.40	5.42	14.07	5.90	14.71	6.39	15.34	6.90	15.97	7.44	16.61	7.98
	7080	14.42	7.05	14.74	7.31	15.36	7.84	15.94	8.38	16.51	8.93	17.08	9.51	17.65	10.10

See Legend and Notes on page 45.

**Table 11D — 40RM High-Capacity Fan Performance Data —
0-600 kPa External Static Pressure — SI (cont)**

UNIT 40RM	AIRFLOW (L/s)	EXTERNAL STATIC PRESSURE (kPa)											
		350		400		450		500		550		600	
		r/s	kW	r/s	kW	r/s	kW	r/s	kW	r/s	kW	r/s	kW
007	850	15.34	0.80	16.25	0.92	17.10	1.03	17.90	1.16	18.66	1.28	19.39	1.41
	850	15.69	0.94	16.61	1.07	17.47	1.20	18.28	1.33	19.04	1.47	19.77	1.61
	1130	16.04	1.09	16.95	1.23	17.81	1.38	18.63	1.53	19.40	1.67	—	—
	1270	16.44	1.27	17.32	1.42	18.17	1.58	18.97	1.74	19.75	1.90	—	—
	1420	16.91	1.49	17.75	1.64	18.56	1.81	19.34	1.97	—	—	—	—
008	1060	15.50	0.96	16.43	1.10	17.31	1.23	18.14	1.37	18.93	1.51	19.68	1.66
	1230	15.84	1.14	16.75	1.28	17.62	1.43	18.45	1.58	19.24	1.74	—	—
	1420	16.34	1.38	17.19	1.54	18.01	1.70	18.81	1.86	19.59	2.03	—	—
	1600	16.97	1.69	17.76	1.85	18.52	2.02	19.27	2.19	—	—	—	—
	1770	17.61	2.01	18.35	2.18	19.07	2.35	19.77	2.53	—	—	—	—
012	1420	16.02	1.33	16.87	1.48	17.71	1.64	18.52	1.80	19.30	1.97	—	—
	1650	16.76	1.70	17.53	1.85	18.29	2.02	19.04	2.19	19.77	2.37	—	—
	1890	17.64	2.16	18.35	2.33	19.05	2.51	19.74	2.69	—	—	—	—
	2120	18.60	2.73	19.28	2.91	19.93	3.10	—	—	—	—	—	—
	2360	19.61	3.40	—	—	—	—	—	—	—	—	—	—
014	1770	15.21	1.78	16.19	2.06	17.13	2.34	18.04	2.64	18.91	2.94	19.75	3.25
	2030	15.46	2.05	16.37	2.33	17.26	2.63	18.12	2.94	18.96	3.26	19.78	3.59
	2360	15.94	2.46	16.78	2.77	17.60	3.08	18.40	3.40	19.18	3.73	19.94	4.07
	2690	16.51	2.95	17.32	3.28	18.09	3.62	18.84	3.96	19.57	4.31	—	—
	2950	16.99	3.39	17.78	3.74	18.54	4.10	19.26	4.47	19.96	4.84	—	—
016	2120	15.21	2.05	16.11	2.33	16.98	2.62	17.83	2.93	18.66	3.24	19.47	3.57
	2500	15.69	2.49	16.54	2.80	17.35	3.12	18.14	3.44	18.90	3.77	19.64	4.11
	2830	16.18	2.94	17.01	3.28	17.79	3.63	18.54	3.97	19.27	4.33	19.97	4.69
	3210	16.75	3.52	17.57	3.90	18.34	4.29	19.08	4.67	19.78	5.06	—	—
	3540	17.26	4.09	18.07	4.50	18.84	4.93	19.57	5.35	—	—	—	—
024	2830	16.01	2.88	16.85	3.22	17.64	3.56	18.39	3.91	19.12	4.26	—	—
	3300	16.67	3.57	17.50	3.96	18.28	4.36	19.03	4.75	19.73	5.15	—	—
	3780	17.35	4.39	18.17	4.82	18.95	5.27	19.68	5.72	—	—	—	—
	4250	18.11	5.37	18.88	5.83	19.63	6.31	—	—	—	—	—	—
	4720	18.96	6.58	19.67	7.05	—	—	—	—	—	—	—	—
028	3540	14.57	3.97	14.95	4.41	15.67	5.07	16.50	5.59	—	—	—	—
	4130	14.76	3.99	15.51	4.57	16.36	5.46	17.00	6.04	—	—	—	—
	4720	15.49	4.92	16.15	5.37	16.78	5.88	17.42	6.50	—	—	—	—
	5310	16.26	6.15	16.91	6.61	17.51	7.08	18.10	7.58	—	—	—	—
	5900	17.04	7.61	17.68	8.11	18.28	8.62	—	—	—	—	—	—
034	4250	14.68	4.00	15.38	4.49	16.12	5.14	17.00	6.15	—	—	—	—
	4960	15.51	5.20	16.17	5.63	16.80	6.09	17.41	6.61	—	—	—	—
	5660	16.35	6.72	17.01	7.21	17.64	7.69	18.23	8.18	—	—	—	—
	6370	17.24	8.54	17.87	9.10	—	—	—	—	—	—	—	—
	7080	18.22	10.70	—	—	—	—	—	—	—	—	—	—

See Legend and Notes on page 45.

Legend and Notes for Tables 11A and 11C

LEGEND

Bhp — Brake Horsepower Input to Fan
ESP — External Static Pressure

NOTES:

1. Maximum allowable fan speed is 1100 rpm for unit sizes 028 and 034; 1200 rpm for all other sizes.
2. Fan performance is based on deductions for wet coil, clean 2-in. filters, and unit casing. See table at right for factory-supplied filter pressure drop.
3. Refer to fan motor and drive tables for additional data.

FACTORY-SUPPLIED PRESSURE DROP — ENGLISH

UNIT	AIRFLOW (Cfm)	PRESSURE DROP (in. wg)
40RM 007	1,800	0.05
	2,400	0.08
	3,000	0.11
40RM 40RMQ 40RMS 008	2,250	0.07
	3,000	0.11
	3,750	0.15
40RMS 010	2,550	0.09
	3,400	0.13
	4,250	0.18
40RM 40RMQ 40RMS 012	3,000	0.11
	4,000	0.17
	5,000	0.23
40RM 40RMS 014	3,750	0.06
	5,000	0.10
	6,250	0.13
40RM 40RMQ 40RMS 016	4,500	0.08
	6,000	0.12
	7,500	0.17
40RM 40RMQ 40RMS 024	6,000	0.12
	8,000	0.19
	10,000	0.26
40RM 40RMQ 40RMS 028	7,500	0.15
	10,000	0.22
	12,500	0.30
40RM 40RMS 034	9,000	0.19
	12,000	0.29
	15,000	0.40

Legend and Notes for Tables 11B and 11D

LEGEND

ESP — External Static Pressure

NOTES:

1. Maximum allowable fan speed is 18.3 r/s for unit sizes 028 and 034; 20 r/s for all other sizes.
2. Fan performance is based on deductions for wet coil, clean 51-mm filters, and unit casing. See table at right for factory-supplied filter pressure drop.
3. Refer to fan motor and drive tables for additional data.

FACTORY-SUPPLIED PRESSURE DROP — SI

UNIT	AIRFLOW (L/s)	PRESSURE DROP (Pa)
40RM 007	850	13
	1150	20
	1450	28
40RM 40RMQ 40RMS 008	1000	17
	1400	27
	1800	38
40RMS 010	1200	21
	1600	32
	2000	45
40RM 40RMQ 40RMS 012	1450	28
	1900	42
	2350	56
40RM 40RMS 014	1750	15
	2350	24
	2950	33
40RM 40RMQ 40RMS 016	2100	20
	2800	30
	3500	42
40RM 40RMQ 40RMS 024	2900	32
	3800	47
	4700	64
40RM 40RMQ 40RMS 028	3500	36
	4700	55
	5900	76
40RM 40RMS 034	4250	47
	5650	71
	7050	98

START-UP CHECKLIST
(SPLIT SYSTEMS WITH 40RM,RMQ,RMS UNITS)

I. PRELIMINARY INFORMATION

OUTDOOR: MODEL NO. _____ INDOOR: MODEL NO. _____
SERIAL NO. _____ SERIAL NO. _____
ADDITIONAL ACCESSORIES _____

II. PRE-START-UP

OUTDOOR UNIT

IS THERE ANY SHIPPING DAMAGE? _____ (Y/N) ____
IF SO, WHERE: _____

WILL THIS DAMAGE PREVENT UNIT START-UP? (Y/N) ____
CHECK POWER SUPPLY. DOES IT AGREE WITH UNIT? (Y/N) ____
HAS THE GROUND WIRE BEEN CONNECTED? (Y/N) ____
HAS THE CIRCUIT PROTECTION BEEN SIZED AND INSTALLED PROPERLY? (Y/N) ____
ARE THE POWER WIRES TO THE UNIT SIZED AND INSTALLED PROPERLY? (Y/N) ____
HAVE COMPRESSOR HOLDDOWN BOLTS BEEN LOOSENEED? (Y/N) ____

CONTROLS

ARE THERMOSTAT(S) AND INDOOR FAN CONTROL WIRING CONNECTIONS MADE AND CHECKED? (Y/N) ____
ARE ALL WIRING TERMINALS (including main power supply) TIGHT? (Y/N) ____
HAVE OUTDOOR UNIT CRANKCASE HEATERS BEEN ENERGIZED FOR 24 HOURS? (Y/N) ____

INDOOR UNIT

HAS WATER BEEN PLACED IN DRAIN PAN TO CONFIRM PROPER DRAINAGE? (Y/N) ____
ARE PROPER AIR FILTERS IN PLACE? (Y/N) ____
HAVE FAN AND MOTOR PULLEYS BEEN CHECKED FOR PROPER ALIGNMENT? (Y/N) ____
DO THE FAN BELTS HAVE PROPER TENSION? (Y/N) ____

PIPING

40RM,RMQ

HAS FOAM SHIPPING BLOCK BEEN REMOVED FROM THE TXV (Thermostatic Expansion Valve)? (Y/N) ____
ARE LIQUID LINE SOLENOID VALVES LOCATED AT THE INDOOR UNIT (40RM) OR OUTDOOR UNIT (40RMQ) COILS AS REQUIRED? (Y/N) _____

HAVE LEAK CHECKS BEEN MADE AT COMPRESSORS, CONDENSERS, INDOOR COILS, TXVs (Thermostatic Expansion Valves) SOLENOID VALVES, FILTER DRIERS, AND FUSIBLE PLUGS WITH A LEAK DETECTOR? (Y/N) ____

LOCATE, REPAIR, AND REPORT ANY LEAKS. _____

HAVE ALL COMPRESSOR SERVICE VALVES BEEN FULLY OPENED (BACKSEATED) (Y/N) ____
ARE THE COMPRESSOR OIL SIGHT GLASSES SHOWING CORRECT LEVELS? (Y/N) ____

40RMS

HAS AIR BEEN BLED FROM SYSTEM? (Y/N) ____
HAVE LEAK CHECKS BEEN MADE AT COMPRESSORS, CHILLERS, VALVES, AND INDOOR COILS? (Y/N) ____
LOCATE, REPAIR, AND REPORT ANY LEAKS. _____

Free Manuals Download Website

<http://myh66.com>

<http://usermanuals.us>

<http://www.somanuals.com>

<http://www.4manuals.cc>

<http://www.manual-lib.com>

<http://www.404manual.com>

<http://www.luxmanual.com>

<http://aubethermostatmanual.com>

Golf course search by state

<http://golfingnear.com>

Email search by domain

<http://emailbydomain.com>

Auto manuals search

<http://auto.somanuals.com>

TV manuals search

<http://tv.somanuals.com>