

Specifications

MVP64a 12 Channel Power Amplifier

Inputs: 4 pairs of gold RCA jacks
Input impedance: 24 k ohms
Outputs: Gold 5 way Binding posts
Output power: 50 watts RMS per channel (8 ohms)
Peak output power: 100 watts RMS per channel (8 ohms)
Ideal impedance: 6-8 ohms
Freq. response: 10 Hz - 40 kHz +/- 1 dB (1w)
S/N ratio: over 105 dB A weighted 50 watts
THD distortion: <0.1% 20 Hz to 20 kHz
IMD distortion <0.01% 60 Hz 7 kHz 4:1 (SMPTE)
Trigger control: 12VDC output 60mA max.
Power: 750 watts 117 VAC
Dimensions: 17" x 3.5" x 10.5"
Weight: 22 lbs (10 kg)
Operating Temp: -20C to +60C (-4F to +140F)

Caution: Never listen to sound that is distorted. If distorted sound is heard, turn the volume down immediately or speaker and/or amplifier damage could occur that is not covered by the warranty. If this problem persists, contact your dealer.

Limited Warranty

Knöll Systems warrants its electronic products except projectors sold in Canada and the USA by authorized Knöll dealers to be free from defects in materials and workmanship. This warranty extends for three full years from the date of purchase by the consumer. Any products returned freight prepaid to Knöll Systems and found to be defective by Knöll Systems within the warranty period will be repaired or replaced at Knöll Systems option, at no charge. Knöll Systems will not be responsible for the actual cost of installation or removal of the product, nor for any consequential or incidental damages. Some states do not allow the exclusion or limitation of incidental or consequential damages, so the above limitation or exclusion may not apply to you. This warranty gives you specific legal rights. You may have additional rights which vary from state to state. Knöll products sold outside of Canada and the USA may be covered by warranties provided by an authorized Knöll distributor. Please contact the distributor in the country that the Knöll product was purchased.

Printed in Canada

Knöll Systems, Richmond, BC & Point Roberts WA

© COPYRIGHT 1998-2003, Knöll Systems, All Rights Reserved

Knöll Systems
tel (604) 272-4555
fax (604) 272-5595

In America:
145 Tye Drive, #1206
Point Roberts, WA 98281

In Canada:
11791 Machrina Way #120
Richmond, B.C. V7A 4V3



MVP64a

Six stereo power amplifiers with
individual volume control electronics
and four input source selection

INSTALLATION MANUAL

It is very important to use a top quality
RJ45 8/8 crimper tool. We strongly
suggest using a cat 5 / RJ45 electronic
tester to verify the wire conductors.

Complies with part 15 of the FCC rules. Operation is subject to:

1. This device may not cause harmful interference
2. This device must accept any interference received including interference that may cause undesired operation.

Version 3.3

Congratulations and thank you for choosing the Knöll MVP64a power amplifier. The MVP64a is designed to meet the amplifier needs of custom installed multi-zone systems where high quality sound is a specific requirement as well as ease of installation and operation.

Key Features:

- 1. Individual zone, four source selection.** Each of the six rooms can select any of the four stereo sources.
- 2. Individual mute, volume, bass, treble and balance adjustment.** Each of the six stereo channels feature adjustments for bass, treble and balance. Individual room keypads control volume and mute. Any keypad can turn the whole system on or off.
- 3. Cost and size efficiency.** The MVP64a consists of a total of 6 stereo power amplifiers with individual volume control electronics in a 3-1/2" enclosure. Each power amplifier channel can deliver 50 watts RMS.
- 4. Automatic protection circuitry.** Each MVP64a channel is individually and fully protected against low impedance, overheating, overloading, overvoltage and undervoltage. The protection circuitry automatically restores the amplifier channel as soon as its parameter returns to the safe operating area.
- 5. External trigger and functions out.** An 12VDC trigger output is provided to turn other components on or off. Six function ports are provided (connects to a 590-00) to turn on and off components via IR as well as provide four IR commands, source from the MR60 keypads
- 6. Stackable 17" chassis.** The MVP64a can be stacked or placed in a 19" EIA equipment rack (requires RK-AMP kit).
- 7. Data port.** For larger systems, multiple MVP64a's can operate in tandem so all MVP64's turn off and on together and share infrared signals, page, connect to door chimes, connect to external controllers, etc.
- 8. Cooling fan.** Fans maximize system performance and helps to avoid early protection system distortion.
- 9. All on and all off.** MR60 keypads turn on any source in all rooms.
- 10. Volume level indication.** MR60 keypads display volume level on top three rows of buttons. FNC-MUTE level is the lowest.
- 11. All room volume up and down** (rooms on only) via FNC button.

Troubleshooting

If a problem is encountered with the MVP64a, the most expedient procedure is to locate the problem and if possible repair it before requesting service. Be sure to carefully check other system components such as controllers, CD players, volume controls, wiring, speakers, etc. that may be at fault.

Problem

Action

- | | |
|-------------------------------------------|---------------------------------------------------------------------------------------------------------------------------------------------------------------------------------------------------------------------------------------------------------------------------------------------------------------------------------------------------------------------------------------------------|
| Power indicator does not light - no sound | <ol style="list-style-type: none">1. Check that the MVP64a is plugged in.2. Test the AC outlet with a lamp..3. Check that the MVP64a power button is on (in). |
| Sound cuts out | <ol style="list-style-type: none">1. Verify speaker impedance is 4-16 ohms. Changing speakers may be required.2. Check if the MVP64a feels hot. If it's hot, increase cooling - see Installation. |
| Sound is distorted | <ol style="list-style-type: none">1. Turn the volume down2. Check speakers for damage.3. Check inputs for proper levels. Source output levels may need adjustment.4. Speakers may have less than 4 ohm rating5. If inputs are Y corded to another MVP64a or stereo receiver, make sure all amps are turned on or a MR24 buffer may be required. |
| MVP64 does not turn off | <ol style="list-style-type: none">1. Press any MR60 keypad "OFF" button or RB8 remote "POWER" button for 5 seconds. The MVP64a should power down and the MVP64a led turns orange (standby). Before turning the MVP64a power switch off (out) we suggest that the MVP64a be in standby |
| Speaker pops when amp turned on or off | <ol style="list-style-type: none">1. Speaker may need resistor placed across terminal. We suggest 2k0 1/4 w resistor which discharges the speakers internal capacitor. |

possible in the sequence to give the components settling time. For example, sequence a power-on command: CD on, tuner on, and CD play rather than CD on, CD play, and tuner ON.

7. Make sure the PROGRAM lamp is on.
8. Make sure the bank 1 switch is on and bank 2, 3 and 4 are off.
9. Push the SEQ (sequence) button.
10. Carefully touch (for one sec.) the wire to the bank 1 + terminal 1 to 6 where the first sequence is to be stored.
11. Move the bank 1 switch off and the bank 2 switch on.
12. Touch the wire to the terminal where the first IR signal of the sequence is stored (for one second). Touch the wire to the terminal where the second IR signal of the sequence is stored (for one second). Touch any other terminals until the entire command sequence is stored.
13. Push the SEQ button and then the PGM button to leave the program mode (lamp goes out).
14. Move the bank 1 switch to on and bank 2, 3, and 4 to off. The sequence is now complete.
15. Repeat steps 7 to 14 for each of the other sequences.

Note: 590-00 programming should be fully tested. Occasionally one source component gets out of sequence especially if IR remote controls are used (most often when using the remote to turn on and off source components). The system user should be shown how to correct for a source component getting out of sequence.

Caution: The MVP64a contains no user serviceable parts, so do not attempt to open or repair the MVP64a. Refer servicing to a qualified technician only or contact the factory for information.

System layout considerations

The MVP64a is the heart of a whole home music system. A MVP64a is designed to work with 1-6 rooms or zones. Up to three MVP64a's can be ganged together to allow up to 18 rooms or zones each individually controlling one or two pairs of enclosure or inwall speakers. Connection is achieved via the data port using a **stereo** 3.5mm jack on the rear of the MVP64a.

Rooms are usually controlled by a MR60 keypad. **The keypads are not intended for outdoor use.** The MR60 contains an almost all brand infrared repeater and most functions can be controlled by the Knoll RB8 remote control. RB8 commands can easily be stored in a learning remote. The MR60 is available with three different source layouts (all of the MR60 keypads in one system have to have the same source layout) and three bezel colors white, almond and ivory for a total of 9 models. The source layout and bezel colors are easy to change in the field.

Some rooms will not require a MR60 keypad and most MVP64a functions can be utilized with an RB8 remote and an infrared repeater (a MR173 IR converter is required). Up to three IR receivers in three different rooms can be connected to a single MR173. The MVP64a includes an internal four single or dual emitter connection block, so emitters will have to be ordered if required. The infrared pass through is always available when the amplifier is turned on and in standby or powered up.

Follow directions from the speaker manufacturers when deciding speaker locations.

Note: The MVP64a prefers 6-8 ohm speaker loads. Connecting to 4 ohm loads won't hurt the MVP64a but those channels connected to 4 ohm loads may occasionally shut down due to overloading. **Never connect the MVP64a to 2 ohm loads.**

The MVP64a has a cooling fan to increase long term power output and reliability.

...continued

...System layout considerations continued

In certain commercial applications a microphone paging override is required. Model MR171 paging and override module takes a balanced or unbalanced mic, (with defeatable phantom power) or a line level input and when activated overrides all inputs (even if some or all zones are in standby) and pages at a preset volume in all zones.

A variety of door chime and telephone paging, door entry and front door camera modules are being developed. Check our web site for more information.

The MVP64a includes a 12VDC trigger output to control and power various items when the MVP64a is powered up. When the MVP64a goes into standby the trigger output ends. It's maximum output is 60mA.

An innovative IR connection system is also included to turn on and off the various source components as well as four separate commands. A Xantech 590-00 controller is required for this purpose. The Xantech 590-00 is an IR sequence generator. When it receives commands from the MVP64a it generates an IR command or sequence of up to 10 commands.

The on command is automatically generated when the MVP64a goes out of standby and into power up. The off command is automatically generated when the MVP64a goes from power on to standby. These sequences are generally used to turn on and off the source equipment.

To activate the four commands, when the system is powered up, press the MR60 keypad button FNC then quickly press one of the four source buttons on the top of the MR60 keypad. This will initiate a pulse at the MVP64a FUNCTION output, that in turn generates an IR command that is pumped back into the MVP64a IR emitter port 1 and out to the various emitters connected to ports 2-3-4, that will initiate the command to the source component.

in bank 1 positions 1 through 6).

The 590-00 can learn up to 16 different commands on each of its four banks. If more than 10 different IR commands are to be stored use bank 2, 3, and 4 to store the sequence commands and bank one positions 1-6 to execute the sequences.

1. Write down the order for each of the sequences required for all of the six functions (not programmed with single commands).
2. Turn the bank 2 dip switch on; bank 1, 3, and 4 off.
3. Push PGM (program lamp goes on).
4. Using the wire attached to the 590-00 +12VDC, touch and hold the other end of the wire to the 590-00 upper + row terminal 1. While holding the wire in place, press the remote control button of the first function while the remote is about 2-4" from the 590-00 internal infrared sensor. The 590-00 PROGRAM lamp will flicker while storing the IR signal. When the IR signal is stored, the confirm lamp comes on. Release the remote control button and release the wire to the upper row terminal. The IR signal is now stored in the 590-00 bank 2 terminal 1.
5. Hold the end of the wire to the 590-00 upper + row terminal 2. While holding the wire in place, press the remote control button of the second function while it is about 2-4 inches from the 590-00 internal infrared sensor. The 590-00 PROGRAM lamp will flicker while storing the information. When the information is stored, the confirm lamp will come on. Release the remote control button and release the wire to the upper row terminal. The IR signal is now stored in the 590-00 bank 2 terminal 2.
6. Continue this procedure until all of the required sequence commands have been learned by the 590-00. If more than 16 IR signals have to be learned, fill up bank 2 with the first 16 IR signals, then turn the bank 2 dip switch off, and the bank 3 switch on. Continue with bank 3 position 1, 2 etc. Use bank 4 positions 1, 2, etc., if required and bank 1 positions 7-16.

Note: When storing an IR signal command sequence, it is most reliable if commands to a component are timed as far apart as

gather all the source remotes (with batteries inserted) near the 590-00. Screw one end of a temporary wire to the 590-00 terminal marked +12VDC. Power up the 590-00 and the MVP64a.

The 590-00 can learn up to 16 different commands on each of its four banks. If more than 10 different IR commands are being stored use bank 2, 3, and 4 to store the sequence commands and bank one positions 1-6 to execute the sequences.

Single IR Command Storing

Start by pushing the RES (reset) button on the back of the 590-00. If any of the six relay activations have a single command (not a sequence of commands), program the single command(s) first. For example if the jazz station tuner is on source C and you want to program the IR command "scan" (two or more news stations have been programmed in the news station tuner) into function C, program the 590-00 with this first.

1. Make sure the bank 1 dip switch is on; bank 2, 3, and 4 off.
2. Push PGM (program lamp goes on).
3. Using the wire attached to the 590-00 +12VDC, touch and hold the other end of the wire to the 590-00 upper + row terminal 2. While holding the wire in place, push the tuner remote control button "scan" while it is about 2-4 inches from the 590-00 internal infrared sensor. The 590-00 PROGRAM lamp will flicker while storing the IR signal. When the IR signal is stored, the confirm lamp comes on. Release the remote control button and release the wire to the upper row terminal. The IR signal is now stored in the 590-00 bank 1 terminal 2.
4. Store any other single commands in bank 1 positions 1 and 3-6.
5. Push PGM (program lamp will go out).

590-00 Sequence IR Command Storing

The six MVP64a pulse activations can activate a sequence of up to 10 IR commands each. As an overview, the individual IR commands are first learned and stored in any of the 16 positions in the four banks (except bank 1 positions 1 through 6), then assembled in order

Installation

It is very important to use a top quality RJ45 8/8 crimper tool. We strongly suggest using a cat 5 / RJ45 electronic tester to verify the wire conductors.

Installing the MVP64a should be relatively easy. With a bit of planning, the MVP64a will give trouble free service for years.

- 1. The most important consideration when installing the MVP64a is cooling.** The MVP64a has a lot of power packed into a small chassis size. When installing it in an equipment stack, it should be the top component. It needs at least 1-3/4" of space above the MVP64a to allow for adequate cooling.
- 2.** When installing the MVP64a in a rack we suggest adding a 1-3/4" blank above and below the MVP64a. In multiple MVP64a installations, plan for a 3-1/2" blank (double) between each MVP64a and a 1-3/4" blank on the top and bottom. Amplifiers should always be the top components in a rack system.
- 3.** If MVP64a channels frequently shut down due to overheating, either the output levels will have to go down or 8 ohm speakers installed. If 8 ohm speakers are installed on all channels and some channels still shut down, call the factory for advice.
- 4.** Connect the MVP64a inputs to the source component outputs with good quality, short as possible RCA jack cables. Connect each channel individually.
- 5.** If source D is not being used we suggest you short both of them out with a RCA shorting jack. This will make the room speakers quieter in standby modes.
- 6.** Connect the MVP64a speaker outputs to speakers using good quality speaker wire. Minimum 16 gauge copper wire is recommended with 14 gauge minimum for runs over 30' (10m) Make sure the speakers in each room are connected in phase.

Note: Ideally the MVP64a likes 6-8 ohm loads. Connecting to 4 ohm loads won't hurt the MVP64a but those channels connected to 4 ohm loads may occasionally shut down due to overloading. **Never connect the MVP64a to 2 ohm loads.**

7. Install MR60 keypads (or infrared receivers) in the rooms with the speakers. Cat 3 or cat 5 wire can be home run to the MVP64a or up to three rooms daisy chained on one wire.

*****Be sure to set the dip switch on the rear of the MR60*****

See the dip switch adjustment below. Connect all eight individual wires using RJ45 connectors. Four wire conductors are needed for each keypad (one unique, common: IR, ground and 12VDC).

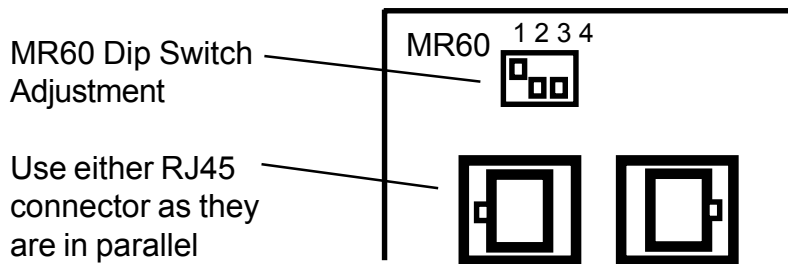

The rear of the MR60 is shown. Because one to three MR60's can be connected or daisy chained to the same cat 5 wire, the keypad position on the wire must be selected using the dip switch. The two MR60 RJ45 connectors are in parallel. Only one dip switch slider should be on and the other two off (#1 is shown on in this example). The MR60 1-2-3 dip switch positions correspond to MVP64 keypad ports and speaker outputs A1-A2-A3 or B1-B2-B3.

*****Even if the keypads are home run, the MR60 dip switch position has to be selected*****

If three keypads are daisy chained on one wire, select the MR60 dip switch on the first MR60 to one, the second MR60 to two and the third MR60 to three. At the rear of the MVP64a, the RJ45 connector from the three MR60 keypads can be connected any corresponding keypad Bank A or Bank B; port 1, 2 or 3. The corresponding speaker outputs will be the same number as selected on the MR60 keypad (example: the MR60 keypad with #2 dip on and connected to MVP64a keypad bank B will control speaker outputs B2R and B2L).

After installation, if the keypads are not working properly or not controlling at all, Check the MR60 dip switch settings, wiring layout and crimp as well as bank connections very carefully.

MVP64a Activation

The 590-00 generates infrared command sequences when a momentary pulse from any of the six MVP64a function outputs are activated. Source A is usually reserved for CD use. When the MVP64a is powered up someone pushing a MR60 Source button or RB8 remote source, the power on (TON) pulse is activated.

Some **examples** to understand when MVP64a pulses are activated and the 590-00 macro sequences are initiated are listed below:
Note: None of the functions below work when any MR60 leds are blinking to indicate MUTE activated.

Pulse O/P	Activates when:	Example IR sequence:
Power On (TON)	Any MR60 or RB8 source key is pushed when all MR60 leds are off.	Sequence power (on) command to all source components
F A (source A CD player)	FNC then Source A (CD) key pushed when system's on and no MR60 blinking led's.	CD skip, CD play or CD random
F B (source B Jazz station)	FNC then Source B (FM or AUX1) key pushed when the system is on.	CD skip to next disk
F C (source C news tuner)	FNC then Source C (Dish AM or CD2) key pushed when the system is on.	Scan to next news station programmed into news tuner
F D (source D sat dish#2)	FNC then Source D (AUX or AUX2) key pushed when the system is on.	Scan up one station

Programming the 590-00

IR functions do not have to be related to the source input. For example, if source A is a CD player and source B is a jazz tuner, function A could be a sequence of CD skip, CD play, and CD random. Function B could be CD Skip to next disk. After deciding and writing down the commands to be programmed for each of the six pulse activations (Function A, B, C, D, TON and TOFF),

MVP64a to Xantech 590-00

The Xantech 590-00 is an infrared learning "remote" capable of converting a dry contact closure of each of the MVP64a's four functions, power-on (TON) and power-off (TOFF) to an IR macro sequence of up to 10 commands each.

The 590-00 power supply is shipped with the 590-00. Power to the 590-00 should be on all the time (like a TV set) so the system IR commands can be sent as soon as any MR60 source buttons are pressed.

The first time installing and programming a 590-00 connected to a MVP64a can be a bit tricky, so please follow these directions closely.

See the diagram on page 7.

Connect the 590-00 rear panel "O" and "G" terminals to the wire pair on the 3.5mm to wire pair (installer supplied). Connect the black wire with the stripe to the "O". Next insert the 3.5mm plug into the rear of the MVP64a labelled "IR Emitters" and "1".

With any type of single conductor wire connect the 590-00 bottom row - terminals 1, 2, 3, 4, 5, 6 and the -12VDC terminal.

DO NOT connect any wires to the TRIG terminal on the MVP64a at this time.

Now connect the MVP64a terminal FD to the 590-00 top row + terminal 1. Next connect the MVP64a terminal FC to the 590-00 top row + terminal 2.

Continue by individually connecting the MVP64a FB, FA, TOFF and TON to the 590-00 top row + terminal 3, 4, 5 and 6. If all of the source equipment has the same IR commands for power-on and power-off, move the wire on the 590-00 connected to terminal +5 (on the + row) with the wire on the 590-00 terminal +6.

8. Connect the emitters to the IR Emitter ports on the rear of the MVP64a. Single or dual emitters can be used. If a Xantech 590-00 is being installed do not connect emitters in the MVP64a IR Emitter #1.
9. When connecting two or more MVP64a's in the same home, connect the amps together using stereo 3.5mm plugs (all three wires are used) to the data plug on the rear of the MVP64a. The MVP64a's share power on and off data as well as infrared signals.

The MVP64a source input RCA jacks are Y-corded together on all amps (source 1 left/right on amp 1 to source 1 left/right on amp 2 etc.)

10. Connect the AC power into an outlet that can supply at least six amps (700 watts) dedicated to each MVP64a.
11. If a Xantech 590-00 is to be installed, the 590-00 needs to be wired to the MVP64a removable 8 terminal connector and the 590-00 has to be programmed.

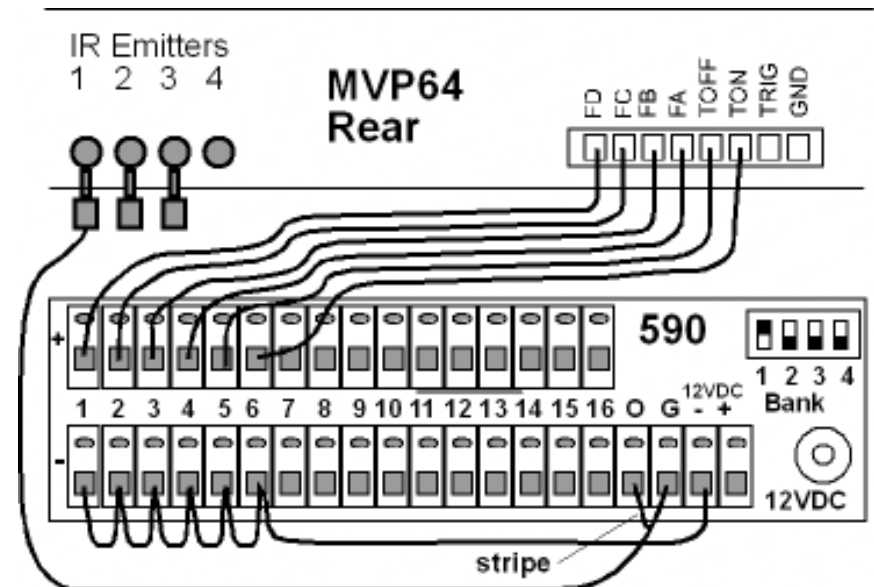

Wiring the 590-00 to the MVP64a

The wire/plug from the 590-00 IR emitter port 1 is a mono 3.5mm with the stripewire to the center/end of the 3.5mm connector. The rest of the wires can be almost any type.

MVP64a Rear Panel

Note 1: Ideal speaker impedance is 6-8 ohms. When using 4 ohm speakers, individual channels may occasionally shutdown due to protection system.

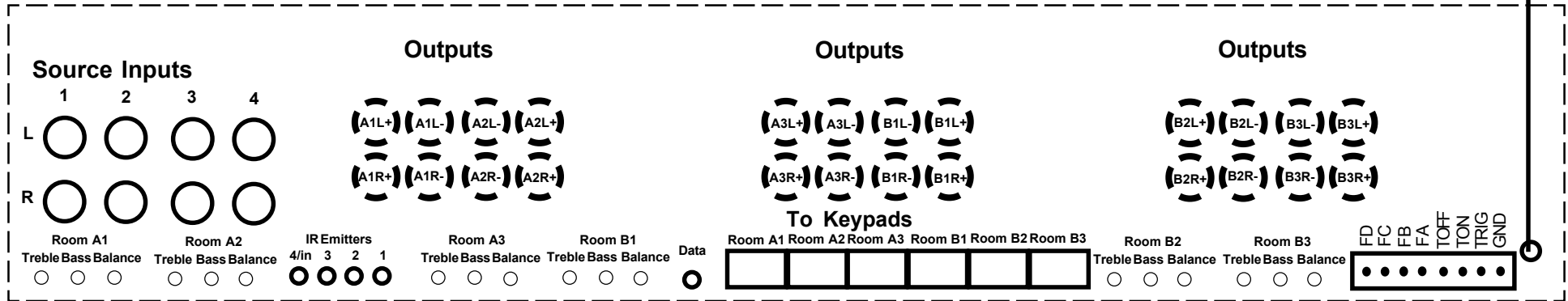
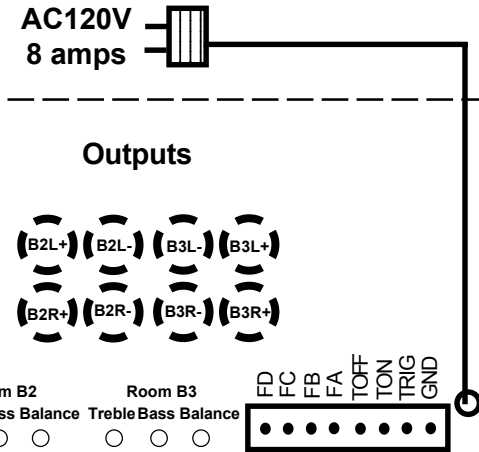

MR60 keypad functions

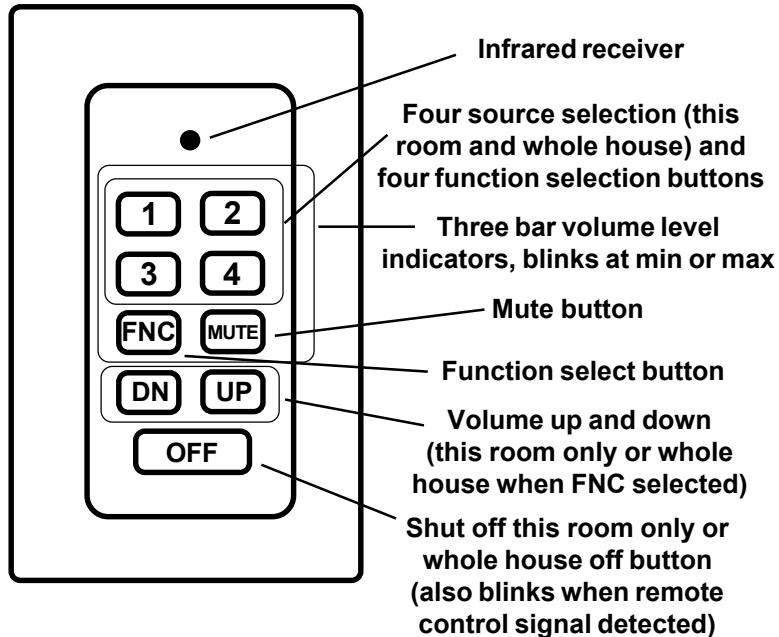

RJ45 plug function identification

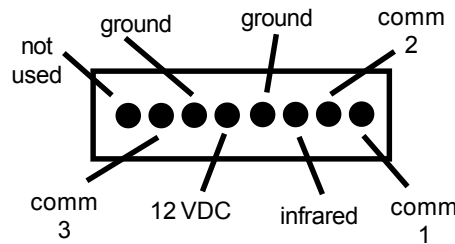

Each RJ45 connector uses 4 wires from MR60 to MVP64a for power, communications and IR. 3 are common, 12VDC, GND (either) and IR. 1 is unique 2-way comm (1, 2 or 3) Comm1 goes to keypad slot A1 or B1 Comm2 goes to keypad slot A2 or B2 Comm3 goes to keypad slot A3 or B3

RJ45 plug color and pair wiring guide

comm 1 brown
white/brown
orange
white/blue
blue
white/orange
green
not used white/green

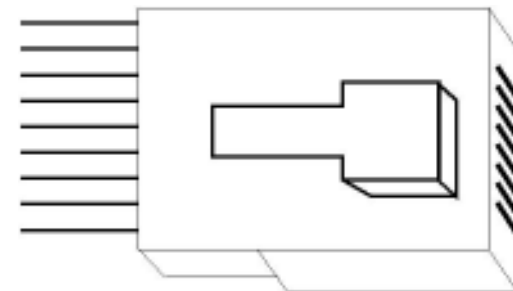

Free Manuals Download Website

<http://myh66.com>

<http://usermanuals.us>

<http://www.somanuals.com>

<http://www.4manuals.cc>

<http://www.manual-lib.com>

<http://www.404manual.com>

<http://www.luxmanual.com>

<http://aubethermostatmanual.com>

Golf course search by state

<http://golfingnear.com>

Email search by domain

<http://emailbydomain.com>

Auto manuals search

<http://auto.somanuals.com>

TV manuals search

<http://tv.somanuals.com>