

User's Guide

KODAK DP2000 Digital Projector

**with KODAK Image
Manager Software**

FCC Warning

This equipment has been tested and found to comply with the limits for a Class A digital device, pursuant to part 15 of the FCC Rules. These limits are designed to provide reasonable protection against harmful interference when the equipment is operated in a commercial environment. This equipment generates, uses, and can radiate radio frequency energy and, if not installed and used in accordance with the instruction manual, may cause harmful interference to radio communications. Operation of this equipment in a residential area is likely to cause harmful interference in which case the user will be required to correct the interference at his own expense.

Canada

This Class A digital apparatus complies with Canadian ICES-003.
Cet appareil numérique de la classe A est conforme à la norme NMB-003 du Canada.

Safety Certifications

UL, CUL, TÜV, NOM

EN 55022 Warning

This is a Class A product. In a domestic environment it may cause radio interference, in which case the user may be required to take adequate measures. The typical use is in a conference room, meeting room or auditorium.

Declaration of Conformity

Manufacturer: Eastman Kodak Company
Rochester, New York 14650 USA

We declare under our sole responsibility that the KODAK DP2000 Digital Projector conforms to the following directives and norms:

Directive 89/336/EEC, Amended by 93/68/EEC

EMI: EN 55022 (1992) Class A

EMC: EN 50082-1 (1992)

IEC 801-2, IEC 801-3, IEC 801-4

Directive 73/23/EEC, Amended by 93/68/EEC

Safety: EN 60950: 1992 + A1 + A2 + A3: 1995

July, 1999

Australian Certification C-tick mark

Table of Contents

Safety Instructions	1
Safety Definitions	1
Important Operating Considerations	2
Battery Use	3
Introduction	5
Image Resolution	5
Compatibility	5
Unpacking the Projector	6
Projector Features	7
Usage Guidelines	7
If You Need Assistance	8
Warranty	10
Setting up the Projector	11
Positioning the Projector	11
Connecting the Projector	12
Starting the Projector	17
Turning Off the Projector	18
Using the Projector	19
Basic Image Adjustment	19
Adjusting the Projector	20
The Remote Control	21
Using the Keypad and Remote Control	23
Using the On-Screen Menus	25
Kodak Menu	35
Maintenance & Troubleshooting	37
Cleaning the Lens	37
Replacing the Projection Lamp	38
Replacing the Batteries in the Remote Control	41
Using the Kensington Lock	41
Troubleshooting	42

Appendix A	47
Specifications	47
Appendix B	49
Portable and Laptop Activation Chart	49
Appendix C	59
Using Video Mirroring with a PowerBook Computer	59
Appendix D	61
Projected Image Size	61
Index	63

Safety Instructions

Please read and follow all safety instructions provided *before* using your new projector. Failure to comply with safety instructions may result in fire, electrical shock, or personal injury and may damage or impair protection provided by equipment. *Please save all safety instructions.*

Safety Definitions

- **Warning:** Statements identify conditions or practices that could result in permanent personal injury.
- **Caution:** Statements identify conditions or practices that could result in damage to your equipment.

Safety Symbols



Attention: For information about use of a feature, please refer to this *User's Guide*.





Warning: Hot surface. Do not touch.



An arrow pointing to the lamp door on the projector.

Safety Terms

- **Warning:** Don't look directly into the lens when the projector is turned on.
-  **Warning:** To replace the lamp, turn the power off and unplug the power cord. To avoid burns, wait 30 minutes before opening the lamp door. Follow all instructions provided in this *User's Guide*.
-  **Warning:** Please use the power cord provided. Connect the power cord to a receptacle with a protective safety (earth) ground terminal.
- **Warning:** Refer all service to qualified service personnel. Servicing your own projector will void the warranty. See "If You Need Assistance" on page 8 for the customer service contact information.
- **Caution:** Don't block ventilation openings.
- **Caution:** Don't set liquids on the projector. Spilled liquids may damage your projector.
- **Caution:** Don't place the projector on a hot surface or in direct sunlight.
- **Caution:** Do not drop the projector. Transport the projector in a Kodak-approved case.

Important Operating Considerations

Do not place the projector on a tablecloth or other soft covering that may block the vents. In the unlikely event of the bulb rupturing, thoroughly clean the area behind the projector and discard any edible items placed in that area.

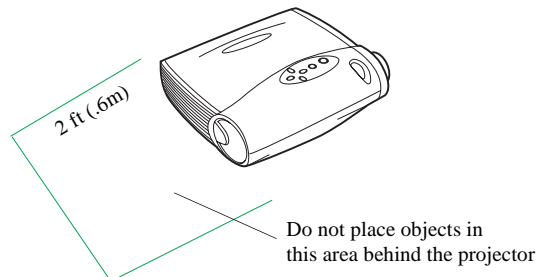

Battery Use

Read and follow all warnings and instructions supplied by the battery manufacturer.

Keep batteries away from children.

Store batteries in their original packaging.

When inserting batteries, verify that the (+) and (-) terminals are aligned correctly.

Replace all batteries of a set at the same time.

Do not mix new batteries with used ones.

Do not use batteries of different chemistries, capacities, brands or sizes together. Leakage could result.

Do not disassemble, recharge, or short-circuit batteries.

Do not subject batteries to high temperature or fire.

Discard used batteries according to all applicable local and national regulations. Utilize established community battery recycling programs where they are available. Consult battery manufacturers for additional information for disposing of batteries.

In the unlikely event of contact with battery electrolyte, customers in the U.S. can contact the Kodak Information Center (KIC) at 1-800-242-2424. U.S. customers can also contact KIC for information regarding electrolyte removal from KODAK product components.

Customers outside the U.S. can contact their local Kodak Customer Service representative.

Introduction

The KODAK DP2000 Digital Projector is specifically designed for the mobile presenter. It packs XGA 1024 x 768 graphics with 16.7 million colors into a small, 4.8 pound package. It generates crisp, clear images using Digital Light Processing™ (DLP) technology. The DP2000 is easy to connect, easy to use, easy to transport, and easy to maintain.

Included with the DP2000 is Kodak's exclusive Image Manager feature. With this feature you can select the image display setting best suited for your specific presentation material and projection environment.

Image Resolution

The XGA resolution of the DP2000's projected image is 1024 x 768. The projector cannot compress screen resolutions above 1024 x 768. If your computer's screen resolution is higher than 1024 x 768, reset it to a lower resolution before you connect the projector.

The DP2000 automatically expands 640 x 480 and 800 x 600 images to 1024 x 768. You can display these images at their native resolutions by turning off the Auto Resize feature. See "Auto Resize" on page 28 for more information.

Compatibility

The projector is compatible with a wide variety of computers and video devices, including:

- IBM-compatible computers, including laptops, up to 1024 x 768 resolution.
- APPLE MACINTOSH and POWERBOOK computers up to 1024 x 768 resolution.
- Most standard VCRs, DVD players, camcorders and laser disc players.

Unpacking the Projector

The projector comes with the items shown here. Check to make sure that all are included. **Contact your dealer of KODAK products immediately if anything is missing.**

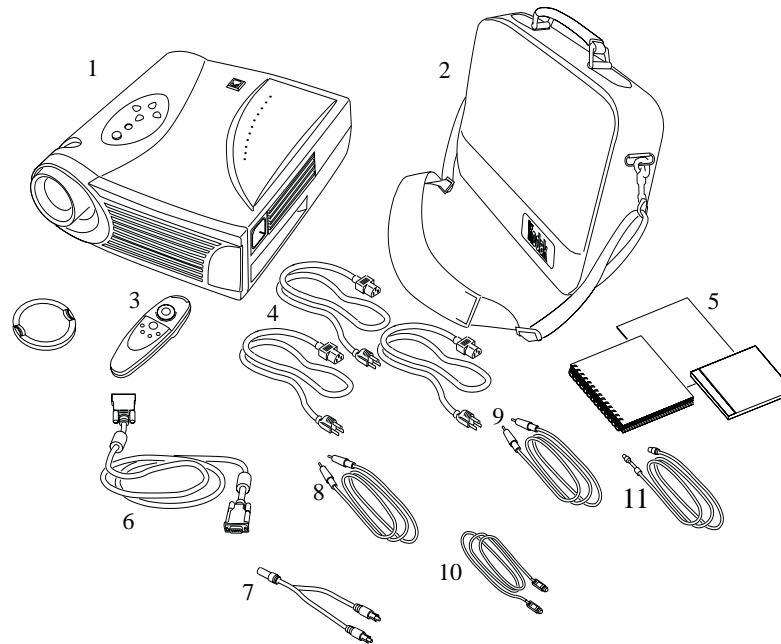

- | | | | |
|----|--|-----|-----------------------|
| 1. | Digital projector and lens cap | 6. | VESA computer cable |
| 2. | Soft carry case | 7. | Audio cable adapter |
| 3. | Remote control | 8. | Audio cable |
| 4. | Power cords (U.S., U.K, Euro) | 9. | Composite video cable |
| 5. | <i>User's Guide, Quick Start Guide, and Online User Guide CD</i> | 10. | USB mouse cable |
| | | 11. | PS/2 mouse cable |

Projector Features

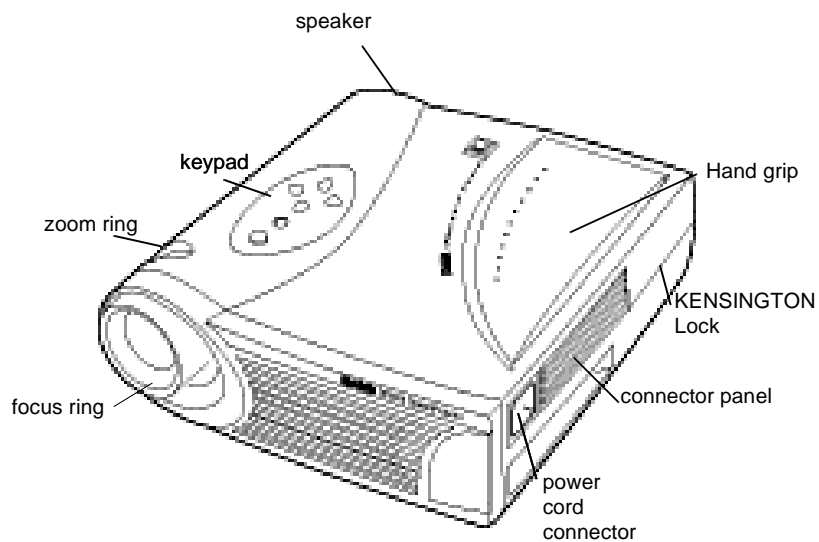

Usage Guidelines

- Do not look directly into the projection lens when the lamp is turned on. The bright light may harm your eyes.
- Do not block the grills on the projector. Restricting the air flow can cause it to overheat and turn off. If this happens, you must wait a minute before attempting to turn it back on.
- Handle the projector as you would any product with glass components. Be especially careful not to drop it.
- Avoid leaving the projector in direct sunlight or extreme cold for extended periods of time. If this happens, allow it to reach room temperature before use.
- Transport the projector in a Kodak-approved hard or soft case.

If You Need Assistance

The first place to look for help is in “Maintenance & Troubleshooting” on page 37. But you can also get help online, by fax, or by phone.

Online Services

Contact Kodak via:

World Wide Web	http://www.kodak.com (click on Service and Support)
America Online	(keyword) KODAK
CompuServe	GO KODAK
Kodak Internet List Server	photo-cd@info.kodak.com; or ftp.kodak.com

Faxed Information

Kodak offers automated support by fax:

U.S. and Canada	1-800-508-1531
Europe	44-0-131-458-6962
U.K.	44-0-131-458-6962

Customer Support

If you have questions concerning the operation of your KODAK projector, you can speak directly to a customer support representative. Have the projector serial number ready, and be at your computer with your projector when you call.

In the U.S. and Canada call toll free, 1-888-375-6325, between the hours of 9:00 a.m. and 8:00 p.m. (Eastern Standard Time) Monday through Friday.

The International Toll Line is +44 (0) 131 458 6714.

In Europe call

Austria/Osterreich	0179 567 357
Germany/Deutschland	069 5007 0035
Spain/Espana	91 749 76 53
Belgium/Belgique	02 713 14 45
Ireland/Eire	01 407 3054
Sweden/Sverige	08 587 704 21
Denmark/Danmark	3 848 71 30
Italy/Italia	02 696 334 52
Switzerland/Schweiz/Suisse	01 838 53 51
Finland/Soumi	0800 1 17056
Netherlands/Nederland	020 346 9372
UK (National Line)	0870 2430270
France	01 55 1740 77
Norway/Norge	23 16 21 33
1 Int. Fax Line	+44 (0) 131 458 6962

Warranty

This product is backed by a limited two-year warranty. The details of the warranty are printed at the back of this manual. A longer term warranty can be purchased from your dealer of KODAK products.

Setting up the Projector

This section describes how to:

- determine where to position the projector
- connect the projector to a computer or a video player
- turn on and turn off the projector

If you are experienced in setting up presentation systems, use the Quick Start card that came with the KODAK DP2000 Digital Projector. Otherwise, follow the procedures described here.

Positioning the Projector

Note: If you want to project from behind a translucent screen, set up the projector behind your screen. See “Rear Projection” on page 31 to reverse the image.

1. Make sure your projector is on a flat surface. It must be within 10 feet (3 m) of your power source and within 6 feet (1.8 m) of your computer.
2. Position the projector the desired distance from the screen.
 - The distance from the lens of the projector to the screen and the zoom setting determine the size of the projected image as shown here. For more information about image sizes at minimum and maximum zoom settings, see “Projected Image Size” on page 61.

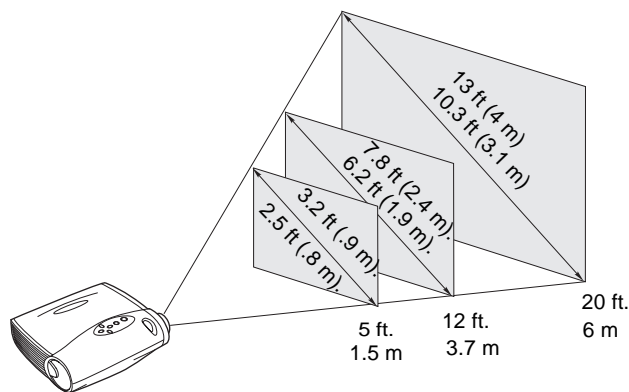

3. Make sure the projector and your computer are turned off.

Connecting the Projector

Icons on the projector will aid you when connecting the projector to a computer or video player.

Caution: Turn off the computer, monitor and projector whenever you connect the components.

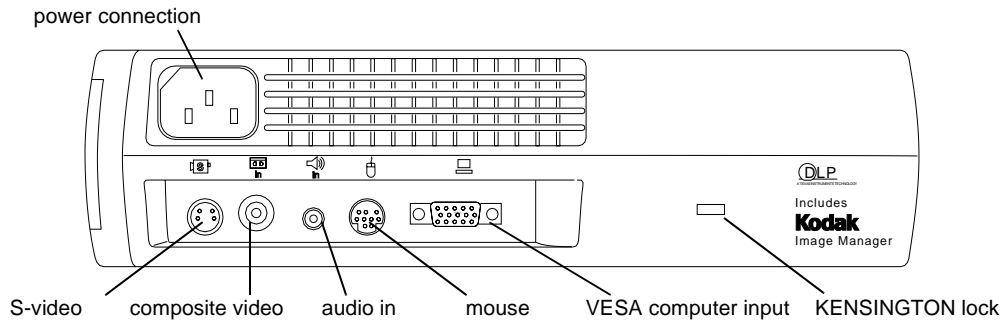

Connecting to a Computer

When you connect the projector to a computer, make sure that the distance between it and the projector is 6 feet or less.

Always use the power cord and VESA cable that shipped with the projector. A surge-protected power strip is recommended.

Many laptop computers do not automatically turn on their external video port when a secondary display device such as a projector is connected. Refer to your computer manual for the command that activates the external video port. Activation commands for some laptop computers are listed in Appendix C.

Note: If you are connecting an older Macintosh computer that does not have a 15-pin connector, use the optional Mac adaptor.

To connect to a computer:

1. Plug one end of the VESA computer cable into the video connector on your computer.
2. Plug the other end of the VESA computer cable in the  connector on the projector

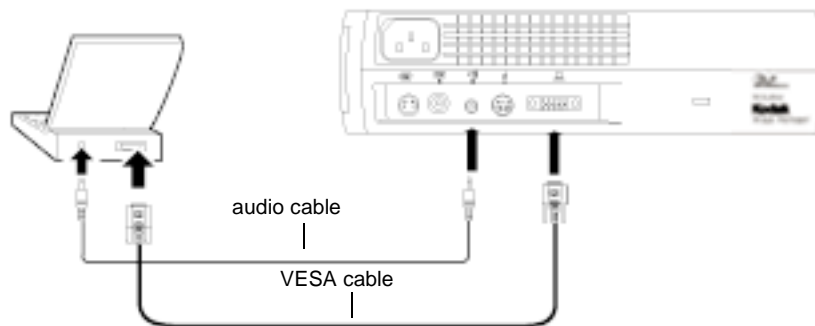

Do you want to play your computer's audio on the projector?



1. Plug either end of the audio cable into the audio connector on your computer.
2. Plug the other end of the audio cable into the  connector on the projector.

Do you want to control the computer's mouse from the projector's remote control or keypad?

If your computer has a PS/2 connector, use the PS/2 mouse cable.

1. Plug the 6-pin end of the PS/2 mouse cable into the mouse connector on your computer.
2. Plug the 8-pin end of the PS/2 mouse cable into the  connector on the cable hub.

If your computer has a USB connector and is running a USB compatible operating system, use the USB mouse cable.

1. Plug the  end of the USB mouse cable into the mouse connector on your computer.
2. Plug the  end of the USB mouse cable into the  connector on the projector.

Note: A USB mouse is hot-pluggable, meaning that you do not need to restart your computer after connecting the mouse to use the mouse. A PS-2 mouse is not hot-pluggable.

Now you're ready to start the projector and computer. Skip to "Starting the Projector" on page 17.



Connecting to a Video Player

If your video player uses a round, one-prong composite video connector, you'll only need the audio cable, audio adaptor, and composite video cable that shipped with the projector.

If your video player uses a round, four-prong S-video connector, you'll need an S-video cable in addition to the audio cable and audio adaptor. The S-video cable is sold separately.

Note: Your video player may have a "Video Out" connector for a coaxial cable connection. Do not use this to connect to the projector.

To connect to a video player:

1. Plug the composite video cable yellow connector into the "video-out" connector on your video player. This connector may be labeled "To Monitor."
 - If you're using an S-video cable, connect it to the "S-video out" connector on the video player.
2. Plug the other yellow connector into the composite video connector  on the back of the projector.
 - If you're using S-video, plug the other end of the cable into the "S-video" connector  on the projector.

Connecting with
composite
video cable

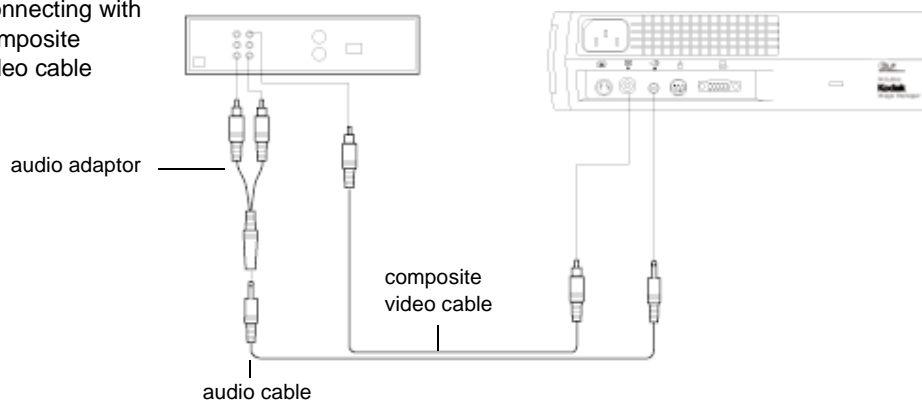

Connecting with
S-video cable

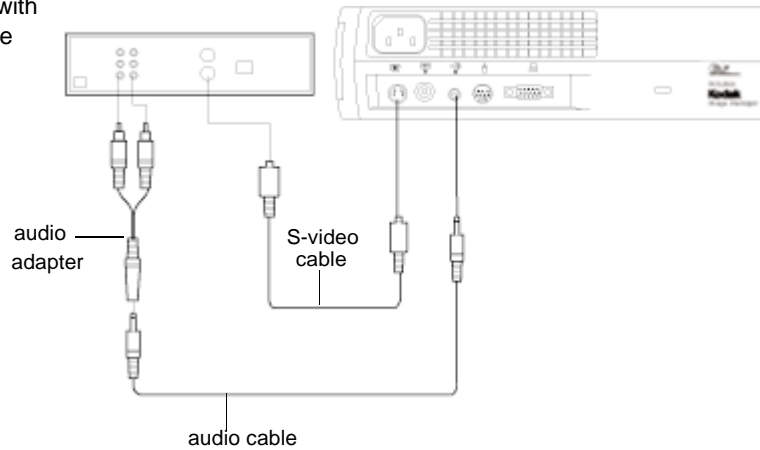

3. Plug the plug the audio adapter white connector into the left “audio out” port on your video player. Plug the adapter red connector into the right “audio out” port on the video player.
4. Plug the other end of the audio adapter into the audio cable.
5. Plug the audio cable into the "audio in"  connector on the projector.







The projector is compatible with these major broadcast video standards: NTSC, NTSC 4.43, PAL, PAL-M, PAL-N, and SECAM. It automatically adjusts to optimize its performance for the incoming video. See “Video Standard” on page 30 for details.

Starting the Projector





Note: We recommend using a surge protector power strip.

1. Remove the lens cap.
2. Plug the power cord into the side of the projector, and then plug it into your electrical outlet.

The fans start to run and the lamp LED on top of the projector lights orange until the software has initialized. Then the LED lights green.

3. Turn on the lamp by pressing the  button on the keypad.
The KODAK startup screen appears.
4. If you connected the projector to a video player, turn on the video player.
 - The video image should appear on the projection screen. If a computer source is active, press the   button on the keypad (page 23) or the  button on the remote to display your video image. You can select a default source to determine which source the projector examines first during power-up for active video; see “Default Source” on page 31.
 - Use the   buttons to adjust the volume.
5. If you connected the projector to a computer, turn on the computer. Make sure the computer external video port is activated. See “Portable and Laptop Activation Chart” on page 49.



Note: With some computers, the order in which you power up the equipment is very important. Most computers should be turned on last, after all other peripherals have been turned on. Refer to your computer documentation to determine the correct order.

- The computer image should appear on the projection screen. If a video source is active, press the   button on the keypad (page 23) or the  button on the remote to display your computer’s image.
- If necessary, make adjustments to the image using the projector’s on-screen menus. To open the menus, press the  button on the keypad or remote, then select the Display or Image sub-menu. For more information about the menus, see “Using the On-Screen Menus” on page 25.

Turning Off the Projector

To completely turn off the projector, unplug it. If you want to turn the projector back on immediately, you must allow about a minute for the lamp to cool. The lamp won't light if it's too hot.

Note: Lamp life will be extended if you turn the lamp off, then wait 1 minute while the lamp cools before unplugging the projector. The Lamp LED will light green when the lamp has cooled. See page 24 for details on the Lamp LED.

If you want to turn off the display for a short period of time, press the  button on the keypad or remote. This blanks the screen for fifteen minutes, but keeps the projector running. (You can change the amount of time the projector stays in standby mode; see "Standby Time" on page 31 for details.) After 15 minutes, the lamp goes out (the projector keeps running). To exit standby mode, press the  button again. (It may take several seconds for the projection lamp to reach full power and project the image again.)

Using the Projector

This section describes how to use and make adjustments to the projector. It also provides a reference to the keypad and remote control buttons and the options available from the on-screen menus.

Basic Image Adjustment

1. Make sure you have turned on your equipment in the right order (page 17).
2. If the image doesn't display completely, zoom the image (page 20), adjust the height of the projector (page 20) or center the image by adjusting its horizontal or vertical position (page 29). Be sure the projector is at a 90 degree angle to the screen.
3. If the image is out of focus, rotate the focus lens (page 20).
4. If the image appears to shimmer or if it has blurry vertical bars after you have adjusted the focus, turn Auto Image (page 28) off and then back on to reset the automatic sync and tracking. If that doesn't clear up the image, turn Auto Image off and adjust the sync (page 29) and/or the tracking (page 29) manually.
5. If the colors don't look right, check the KODAK Image Manager settings. See "Kodak Menu" on page 35

Or

Adjust the brightness (page 26) and the tint (page 27).

Adjusting the Projector

To focus the image, rotate the focus ring until the image is clear. To zoom the image, rotate the zoom ring. This adjusts the image size without affecting focus.

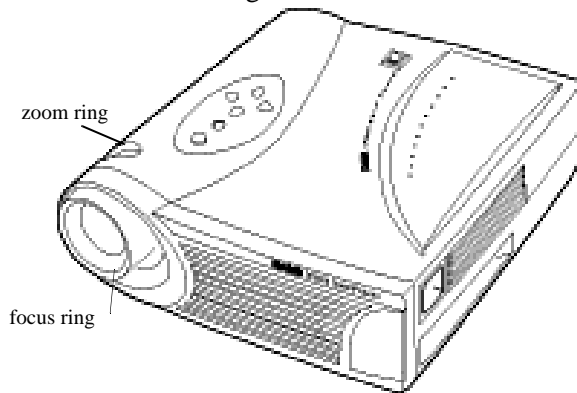

The projector is equipped with a self-locking, quick-release elevator foot and button.

To raise the projector:

1. Press and hold the elevator button.
2. Raise the projector to the height you want, then release the button to lock the elevator foot into position.

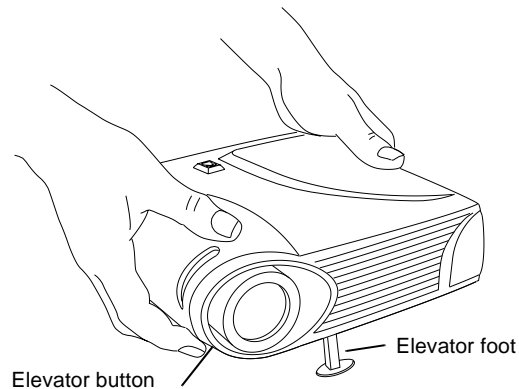

The Remote Control

The projector ships with a remote that has four function buttons, a disk mouse and two mouse buttons, one on the top of the remote and one on the bottom.

Point the remote control at the projection screen or at the front or rear of the projector. The range for optimum operation is about 25 feet (7.6 m). If you point the remote at the projection screen, the distance to the screen and back to the projector must not be more than 25 feet (7.6 m). For best results, point the remote directly at the projector.

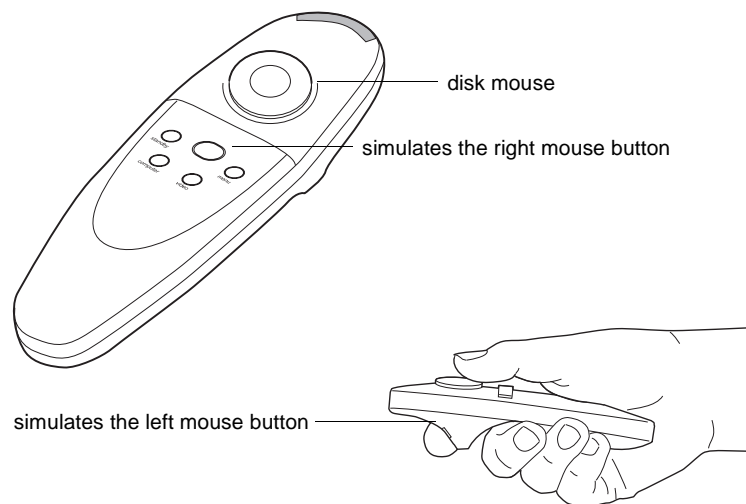

Note: If the remote is inactive for several minutes, it “sleeps” to conserve battery life. Press any button except the disk mouse to re-activate the remote.

Press anywhere on the edge of the disk mouse to move the cursor on the screen. You can move the cursor at any angle by pressing the corresponding edge of the disk. The mouse button on the top of the remote simulates your computer's right mouse button; the button on the bottom simulates your computer's left mouse button. See "Using the Keypad and Remote Control" starting on page 23 for a description of the four function buttons.

If you are creating presentations in MICROSOFT® POWERPOINT®, you can use the remote's mouse buttons to navigate through your presentation while in Slide Show mode. To configure POWERPOINT for this, choose Options from the Tools menu, click the View Tab, de-select the "Popup Menu on Right Mouse Click" option in the Slide Show section, then click OK. Then, when you're in POWERPOINT's Slide Show mode, a left click advances to the next slide and a right click returns to the previous slide (other POWERPOINT modes are not affected).

Using the Keypad and Remote Control

While the menus are displayed, the volume, source, and standby buttons on the keypad act as menu navigation buttons. See “Using the On-Screen Menus” on page 25 for details.

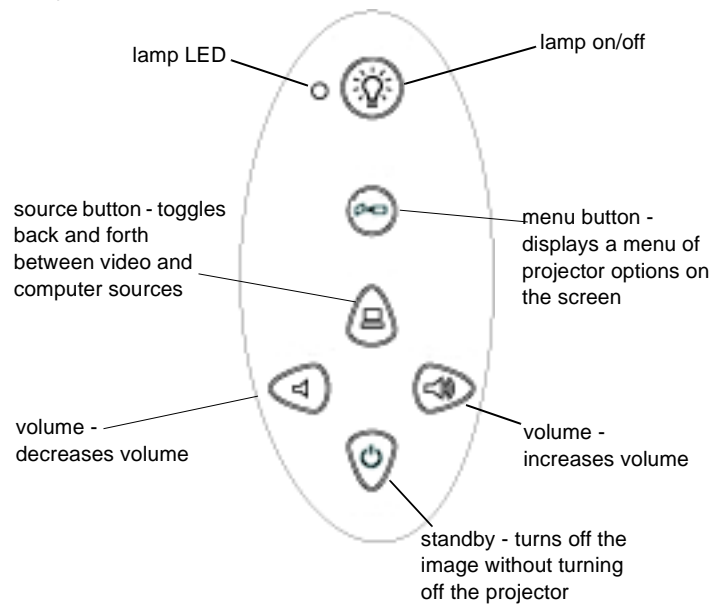

The Keypad Buttons.



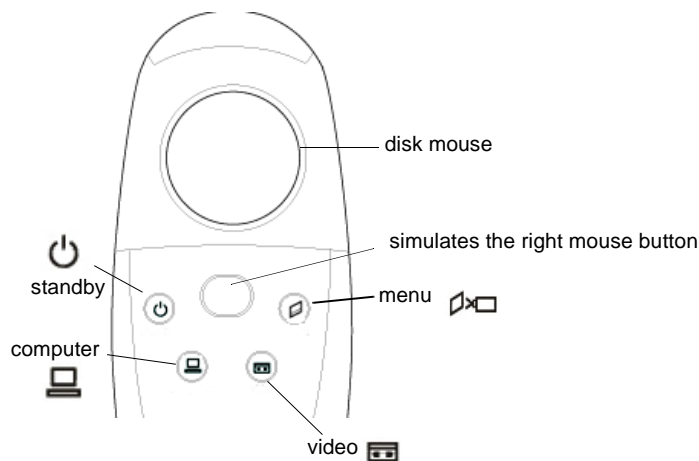

The Remote Control Buttons





Lamp on/off (keypad only)

Press the  button to turn the lamp on or off. The Lamp LED indicates the state of the lamp. A green Lamp LED indicates that you can turn the lamp on, or the lamp is currently on. An orange LED indicates the software is initializing or the lamp is cooling. Do not press the  button when the LED is orange.

Menu



Press  to open the on-screen menus (the keypad lights green). Press  again to close the menus. When you close the menus, the projector saves any changes you made. For more information about the on-screen menus, see “Using the On-Screen Menus” on page 25.

Source (keypad only) or Computer and Video (remote control only)



When you have more than one source (computer and video) connected to the projector, select between them by pressing the  button on the keypad or the  or  button on the remote.

Standby

When you press , the display and audio turn off and a blank screen is displayed for 15 minutes. You can change the amount of time the projector stays in standby mode; see “Standby Time” on page 31 for details.

- If you press  again within 15 minutes, the projector returns to normal operations immediately.
- If you don't press  again, the lamp turns off after 15 minutes.
- If you press  again after 15 minutes, wait until the lamp LED is green.

Volume (keypad only)

- To increase the volume, press .
- To decrease the volume, press .

Volume adjustments are saved for each source that you have connected.

Using the On-Screen Menus

The projector has seven drop-down menus that allow you to make image adjustments and change a variety of settings. Most of these adjustments aren't available directly from the keypad.

Note: Some menu items may be grayed out at certain times. This indicates that the item is not applicable to your setup (for example, video standards do not apply to computer sources) or the item is not enabled until another selection is made (for example, Manual Tracking is not available until Auto Image is turned off).

To open the on-screen menus, press the  button on the keypad or remote. This changes the volume, source, and standby buttons on the keypad to menu navigation buttons. Press the corresponding buttons to move the cursor up, down, left, or right, or use the disk mouse on the remote. To select a menu, move the cursor left and right to highlight the menu you want. The drop-down menu appears.

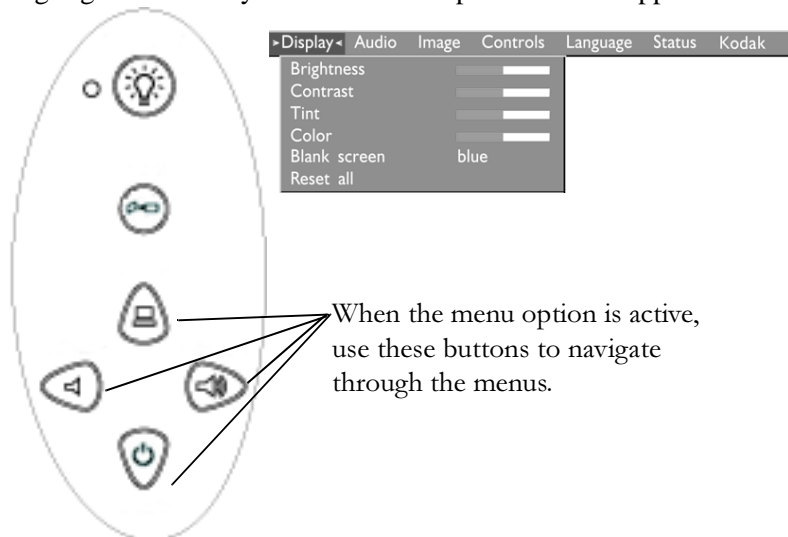

To change a menu setting, use the up and down navigation buttons on the keypad or the disk mouse on the remote control to move the cursor up and down to the item you want to change (the selected item is highlighted red), then use the left and right navigation buttons to adjust a setting.

Some submenus, such as Brightness, consist of a slider bar you use to increase or decrease a value. Some submenus, such as Standby Time, consist of options you scroll through to select the desired one. All changes are saved when you close the menu.

To access another menu, use the up and down navigation buttons or the disk mouse on the remote control to move back to the top of the current menu, then use the left and right navigation buttons to move to another menu.

Display Menu

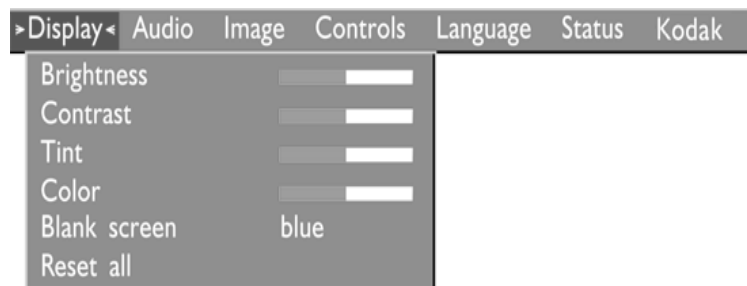

Brightness

Adjusting the brightness changes the intensity of the image.

- Press the left navigation button to darken the image.
- Press the right navigation button to lighten the image.

Contrast

Contrast controls the degree of difference between the lightest and darkest parts of the picture. Adjusting the contrast changes the amount of black and white in the image.

- Press the left navigation button on the keypad to decrease the contrast.
- Press the right navigation button on the keypad to increase the contrast, making the blacks appear blacker and the whites appear whiter.

Tint

The tint adjusts the red-green color balance in the projected image. Changing the Tint setting has no effect on PAL or SECAM video sources.

- Press the left navigation button on the keypad to increase the amount of green in the image.
- Press the right navigation button on the keypad to increase the amount of red in the image.

Color

The color setting adjusts a video image from black and white to fully saturated color.

- Press the left mouse button to decrease the amount of color in the image.
- Press the right mouse button to increase the amount of color in the image.

Blank Screen

Blank Screen determines what color is displayed when there is no active source and when the projector is in standby. Click the left or right navigation button to toggle between blue and black.

Reset All

Click the left or right navigation button to reset all the options (except Language, Video Standard, Rear Projection, and Standby Time) in all the menus to their original settings.

Audio Menu



Volume

Note: Changing the volume from the menu is the same as changing it using the keypad.

- Press the left navigation button to decrease the volume.
- Press the right navigation button to increase the volume.

Volume adjustments you make are saved for each source.

Image Menu

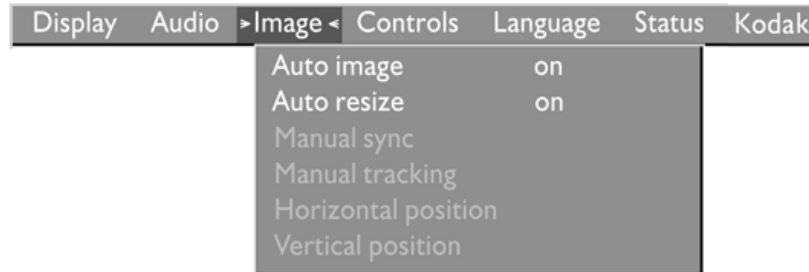

Auto Image

Note: Some screen savers interfere with the operation of Auto Image. If you're experiencing problems, try turning your screen saver off, then turning Auto Image off and back on.

The projector automatically adjusts tracking, signal synchronization and vertical and horizontal position for most computers (Auto Image does not apply to video sources). If you want to adjust these features manually, you must turn off **Auto Image** first by highlighting Auto Image in the Image menu and clicking either the left or right navigation button to select "off".

Auto Resize

Auto Resize automatically resizes the image by scaling it up. It only affects computer images that are not the projector's native resolution.

When **Auto Resize** is on, the projector makes the best fit of the image to the screen. If you turn **Auto Resize** off (by highlighting it in the Image menu and clicking the left or right navigation button to select "off"), the image may be either cropped or too small for the screen.

Manual Sync

Note: The **Manual Sync** option is available only for computer sources. The projector sets this option automatically for a video source.

The projector adjusts signal synchronization automatically for most computers. But if the projected computer image looks fuzzy or streaked, try turning **Auto Image** off then back on again. If the image still looks bad, try adjusting the signal synchronization manually:

1. Turn Auto Image off.
2. Highlight Manual sync, then press the left or right navigation button repeatedly until the image is sharp and free of streaks.

Manual Tracking

The projector adjusts tracking automatically to match the video signal from your computer. However, if the display shows evenly spaced, fuzzy, vertical lines or if the projected image is too wide or too narrow for the screen, try turning **Auto Image** off then back on again. If the image is still bad, try adjusting the tracking manually:

Note: **Manual Tracking** option is available only for computer sources. The projector sets this option automatically for a video source.

1. Turn Auto Image off.
2. Highlight Manual tracking, then press the left or right navigation button repeatedly until the fuzzy vertical bars are gone.

Horizontal position

Note: The **Horiz. Position** option is available only for computer sources. The projector sets this option automatically for a video source.

Follow these steps to manually adjust the horizontal position:

1. Turn Auto Image off.
2. Highlight Horizontal position, then press the left navigator button to move the image right or press the right navigator button to move the image left.

Positioning adjustments are saved when you unplug the projector.

Vertical position

Note: The **Vert. Position** option is available only for computer sources. The projector sets this option automatically for a video source.

Follow these steps to manually adjust the vertical position.

1. Turn Auto Image off.
2. Highlight Vertical position, then press the left navigation button to move the image down or press the right navigation button to move the image up.

Positioning adjustments are saved when you power off the projector.

Controls Menu

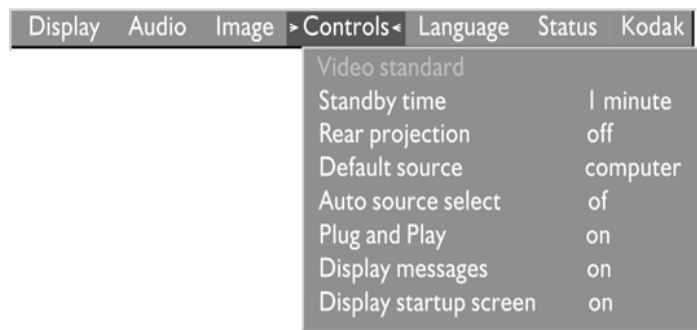

Video Standard

When Video standard is set to Auto, the projector attempts to pick the video standard (NTSC, NTSC 4.43, PAL, PAL-M, PAL-N, or SECAM) automatically based on the input signal it receives. (The video standard options may vary depending on your region of the world.) If the projector is unable to detect the correct standard, the colors might not look right or the image might appear “torn.” If this happens, manually select a standard by clicking either the left or right navigation button and cycling through the standards.

Note: If you already know the video standard used in your geographical area, it's best to manually select it.

Standby Time

This option lets you select how long the lamp stays on and how long the blank screen is displayed in standby mode before the projector turns off. Select among 1, 5, 10, and 15 minutes and 1 and 2 hours by clicking the left or right navigation button and cycling through the options.





Rear Projection

When you turn **Rear Projection** on, the projector reverses the image so you can project from behind a translucent screen. Highlight Rear Projection, then click the left or right navigation button to turn this feature on and off.

Default Source

Default Source toggles between Computer and Video. This determines which source the projector checks first for active video during power-up. Highlight Default Source and click the left or right navigation button to toggle between the options.

Auto Source Select

This setting toggles between On and Off. When this feature is Off, the projector defaults to the source selected in Default Source. To display another source, you must manually select one by pressing the   button on the keypad or the  or  button on the remote control. When this feature is On, the projector automatically finds the active source, checking the default source first. Highlight Auto Source Select and click the left or right navigation button to turn this feature on and off.

Plug and Play

This setting toggles between On and Off. When it is On, most new computers will automatically recognize the projector, then set the monitor resolution and refresh rate accordingly. You need to set the Plug and Play setting to Off for the projector to display properly on some older computers. The Plug and Play setting does not affect video images.

If the projector's display constantly changes between the computer image and the message, "Perfecting the image", you may need to set Plug and Play to Off.

Display Messages

This setting toggles between On and Off. When this feature is On, status messages such as "No signal detected" or "Standby Active" appear in the lower-right corner of the screen. Click the left or right navigation button to turn this feature off and not see status messages.

Display Startup Screen

This setting toggles between On and Off. When this feature is On, the KODAK startup screen appears when the projector starts up and remains until an active source is detected. The startup screen contains information on contacting Kodak. Click the left or right navigation button to turn this feature off and display a plain black or blue screen instead of the startup screen.

Language Menu

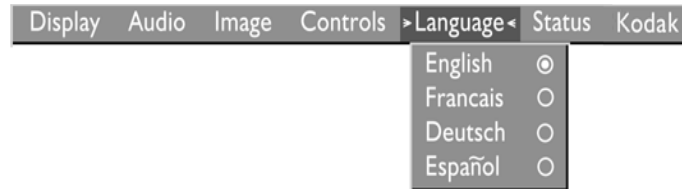

You can display the on-screen menus in English, French, German, and Spanish.

Move the cursor to the language you want, then click the left or right navigation button. The menus redraw immediately.

Status Menu

This is a read-only window for informational purposes. To display the status window, select Show status from the menu, then click the left or right navigation button. To remove the window, click the left or right navigation button.

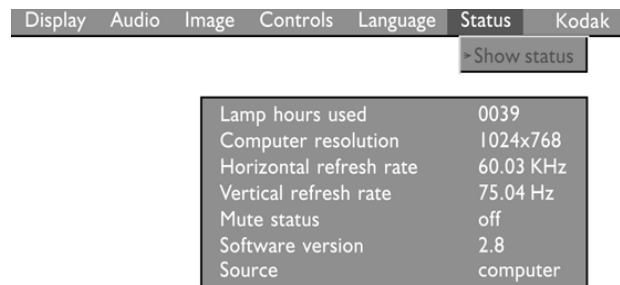

Lamp hours used

Indicates how many hours the current lamp has been in use. The counter starts at zero hours and counts each hour the lamp is in use. Change the bulb when the brightness is no longer acceptable. See “Replacing the Projection Lamp” on page 38 for details.

Computer resolution

Shows your computer's resolution setting. To change this, go to your computer's Control Panel and adjust the resolution in the Display tab. See your computer user's guide for details.

Horizontal refresh rate

The time period that one horizontal line is displayed.

Vertical refresh rate

The time period that one video frame is displayed.

Mute status

Indicates if the audio is muted.

Software version

Indicates the projector's software version. This information is useful when contacting Technical Support.

Source

Indicates the active source, Computer or Video.

Kodak Menu

Kodak's exclusive Image Manager feature allows you to select the image display setting best suited for your specific presentation material and projection environment.



Image Manager Settings

Photo-PC Setting matches the higher contrast found on a standard PC monitor. This option is best for:

- images created on a PC
- images from a KODAK digital camera
- a starting point for composite or S-video inputs.

Photo-Mac Setting matches the lower contrast found on a standard MACINTOSH monitor. It is generally used for images created on or for a MACINTOSH. This setting also works well with a PC if you are using higher than normal contrast PC images.

Rich Colors results in an image with deep contrast and saturated vibrant colors. It is generally used under bright lighting conditions. This setting works well to enhance colors of certain graphics and it may be useful when images created for a MACINTOSH are displayed from a PC.

Spreadsheets results in an image with contrast between a PC and MACINTOSH monitor. It is generally used for text-rich tables, such as financial displays. This setting factors in ambient light, subject matter, and personal preferences to deliver the right balance of contrast and brightness.

Graphics delivers the maximum brightness and high contrast needed to project graphics and text against solid colored backgrounds.

Using the Image Manager

1. Click the Kodak menu.
2. Select the setting best suited for your presentation material and environment.

The new contrast setting is immediately applied to the image.

3. Click OK to save the setting as your default Image Manager setting for the current and future presentations.

Maintenance & Troubleshooting

This section describes how to:

- clean the lens
- replace the projection lamp
- replace the batteries in the remote
- use the Kensington lock feature
- troubleshoot the projector

Cleaning the Lens

Follow these steps to clean the projection lens:

1. Apply a non-abrasive camera lens cleaner to a soft, dry cloth.
 - Avoid using an excessive amount of cleaner.
 - Abrasive cleaners, solvents or other harsh chemicals might scratch the lens.
2. Lightly wipe the cleaning cloth over the lens in a circular motion.
3. If you don't intend to use the projector immediately, replace the lens cap.

Replacing the Projection Lamp

Caution: To avoid burns, allow the projector to cool for at least 30 minutes before you open the lamp module door. Never extract the lamp module while the lamp is operating.

The lamp hour counter in the Status menu counts the number of hours the lamp has been in use. Replace the lamp when the brightness is no longer acceptable. You can order new lamp modules from your dealer of KODAK products.

Follow these steps to replace the projection lamp:

1. Turn off the projector by unplugging the power cord.
2. Wait 30 minutes to allow the lamp to cool thoroughly.
3. Invert the projector on a flat surface, then insert a small screwdriver or other flat object into the tab on the lamp module door.

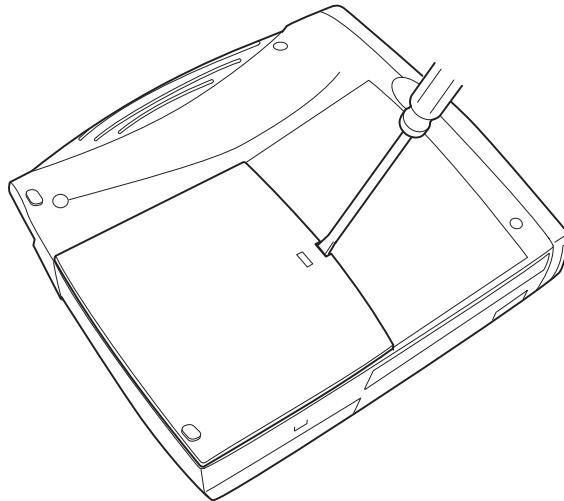

4. Pull the lamp door up and remove it.

Caution: Never operate the projector with the lamp door open or removed. This disrupts the air flow and causes the projector to overheat.

5. Loosen the two non-removable screws on the outside of the module.

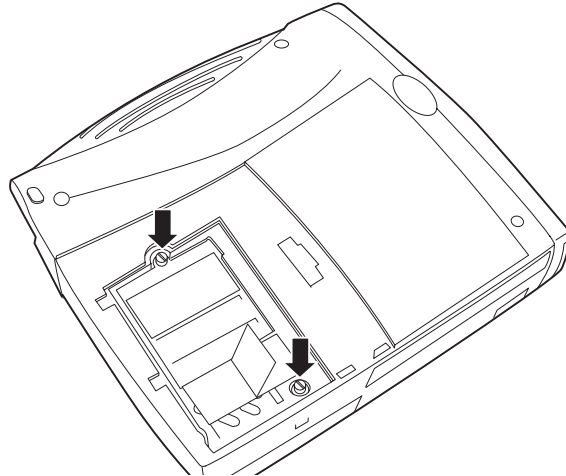



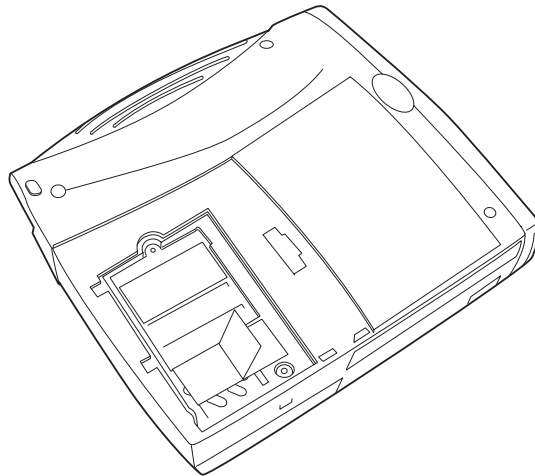

6. Grasp the pull tab and lift out the lamp module.
Be careful when removing the lamp module so that it does not break.



7. Install the new lamp module, being sure to align the connectors properly.

**Caution: Do not drop the lamp module or touch the glass bulb!
The glass may shatter and cause injury.**

8. Gently push the module in until it is flush with the bottom case of the projector.
9. Tighten the screws on the outside of the module.
10. Replace the lamp door by inserting the hooks on the rear of the lamp door into the projector and pressing the lamp door into place.
11. Plug in the power cord to turn the projector back on.
12. To reset the lamp hour counter in the Status window, press and hold the  button, then press the  button (while still holding down the  button) for 5 seconds. Verify that the counter was reset by pressing the  button and viewing the counter in the Status window.

Replacing the Batteries in the Remote Control

The life of the batteries depends on how often and how long you use the remote control. Symptoms of low battery charge include erratic responses when using the remote control and a reduced range of operation.

Follow these steps to replace the batteries:

1. Turn the remote control face down in your hand.
2. Slide the battery cover off the end of the remote control.
3. Remove the old batteries and properly dispose of them.
4. Install two new AAA alkaline batteries. Make sure you install each battery in the correct direction.
5. Slide the battery cover back on the remote control.

Using the Kensington Lock

The projector has a Kensington Security Standard connector for use with a Kensington MicroSaver Security System. Refer to the information that came with the Kensington System for instructions on how to use it to secure the projector.

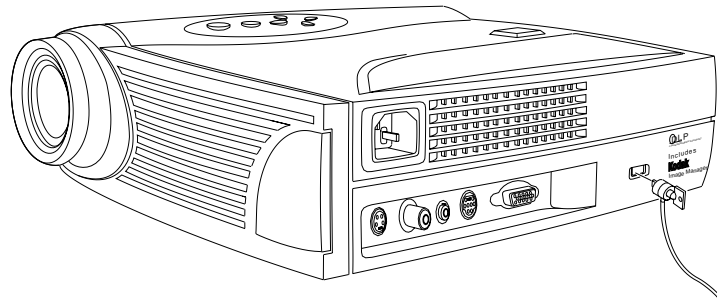

Troubleshooting

Problem: Nothing on projection screen

- Make sure that the power cord is properly connected to a fully functional AC electrical outlet. Make sure that the power cord is also properly connected to the projector.
- If the projector is plugged into a power strip, make sure the power strip is turned on.
- Make sure you have removed the lens cap on the projection lens at the front of the projector.
- Make sure the lamp is switched on.
- Check the projector's lamp to ensure that it is securely connected in the lamp module. See "Replacing the Projection Lamp" on page 38.
- Make sure that the cables do not have any bent pins.

Problem: Color or text not being projected

- You might need to adjust the brightness up or down until the text is visible. Refer to "Brightness" on page 26 for more information.

Problem: The screen resolution is not right

- Make sure the computer's video card is set for a resolution of no greater than 1024 x 768.

Problem: Image isn't centered on the screen

- Move the projector to reposition the image.
- Reposition the image using the software. Refer to "Horizontal position" on page 29 and "Vertical position" on page 30.
- Be sure the projector is at a 90 degree angle to the screen.

Problem: Only the start-up screen displays

- Verify that the cables are connected correctly. See page 12 through page 16 for connection procedures.
- Verify that the proper input source is selected. See “Source (keypad only) or Computer and Video (remote control only)” on page 24.
- You might need to turn everything off and turn on the equipment again in the proper order. Refer to your computer documentation to determine the correct order.
- Make sure your laptop external video port is turned on. See the “Portable and Laptop Activation Chart” on page 49 in this guide or your computer’s manual for details.
- Make sure your computer video board is installed and configured correctly.
- Make sure your computer has a compatible video board. The projector isn’t CGA, EGA or SXGA compatible.

If you’re using Windows 98:

1. Open "My Computer" icon, the Control Panel folder and then the Display icon.
2. Click the Settings tab.
3. Verify that the Desktop area is set to 1024 x 768 or less.

Problem: Image is too wide or narrow for screen

- Adjust the zoom or projector placement.
- Adjust the resolution of your video card if it’s greater than 1024 x 768.

Problem: Image is out of focus

- Turn the projection lens to focus the image.
- Make sure the projection screen is at least 5 feet (1.5 m) from the projector.
- Check the projection lens to see if it needs cleaning.

Problem: Image and menus are reversed left to right

- Rear projection mode is probably turned on. Turn Rear Projection off in the Controls menu. The image should immediately return to forward projection. See “Rear Projection” on page 31.

Problem: the projector displays vertical lines, “bleeding” or spots

- Adjust the brightness. See “Brightness” on page 26.
- Check the projection lens to see if it needs cleaning.

Problem: no sound

- Adjust the volume.
- Verify the audio/input connections.
- Adjust the audio source.

Problem: Image is “noisy” or streaked

Try these steps in this order.

1. Deactivate the screen saver on your computer.
2. Turn **Auto Image** off and then back on again. See “Auto Image” on page 28.
3. Turn **Auto Image** off and adjust the synchronization and tracking manually to find an optimal setting. See “Manual Sync” on page 29 and “Manual Tracking” on page 29.
 - The problem could be with your computer’s video card. If possible, connect a different computer.

Problem: Projected colors don't match the computer or video player's colors

Just as there are differences in the displays of different monitors, there are often differences between the computer image and the projected image.

- Adjust the colors using the KODAK Image Manager. See “Kodak Menu” on page 35.
- Adjust the brightness, tint and/or contrast from the Display menu. See “Brightness” on page 26, “Tint” on page 27 and “Contrast” on page 26.

Problem: Lamp seems to be getting dimmer

- The lamp begins to lose brightness when it has been in use for a long time. Replace the lamp as described in “Replacing the Projection Lamp” on page 38.

Problem: Lamp shuts off

- A minor power surge may cause the lamp to shut off. Unplug the projector, wait at least a minute, then plug it back in.
- Make sure the vents are not blocked.

To contact KODAK support see “If You Need Assistance” on page 8.

Appendix A

Specifications

The projectors must be operated and stored within the temperature and humidity ranges specified.

Temperature

Operating	50 to 104° F (10 to 40° C)
Non-operating	-4 to 158° F (-20 to 70° C)

Humidity

Operating and non-operating	5% to 95% relative humidity, non-condensing
-----------------------------	--

Dimensions

8.9 x 10 x 2.8 inches (22.6 x 25.4 x 7.1 cm)

Weight

4.8 lbs (2.2 kg) unpacked

Altitude

Operating	0 to 10,000 feet (3,048 meters)
Non-operating	0 to 40,000 feet (12,192 meters)

Optics

Focus Range 4.9 - 16 feet (1.5 - 5 m)

Lamp

Type 120-watt VIP lamp

Input Power Requirements

100-120VAC 6A; 50/60Hz

200 - 240VAC 3A; 50Hz

Audio Input

Input Impedance 10K ohm nominal, AC coupled

Maximum Input Voltage $(L_{IN} + R_{IN})_{PEAK} < 4.5 \text{ V}$ for
THD $\leq 0.3\%$
 L_{IN} or $R_{IN} < 2.0 \text{ Vrms}$ for THD
 $\leq 0.3\%$

Sensitivity 100 mV at 1 KHz for 88 dB
SPL at 1 meter

Connector Type 3.5 mm (1/8 inch) stereo phone
mini

Appendix B

Portable and Laptop Activation Chart

Many laptop computers do not automatically turn on their external video port when a secondary display device such as a projector is connected. Activation commands for some laptop computers are listed in the following table. (If your computer is not listed or the given command does not work, refer to the computer's documentation for the appropriate command.) On many laptops, the activation function key is labeled with an icon, for example  or the text CRT/LCD.

Note: Usually, pressing the key commands once activates the external video port, pressing it again activates both the external and internal ports, and pressing it a third time activates the internal port. Refer to your computer documentation for details on your specific model.

Computer	Key command to activate port	Key command to de-activate port
Acer	Ctrl-Alt-Esc (for setup)	Ctrl-Alt-Esc (for setup)
AST* **	FN-D or Ctrl-D	FN-D or Ctrl-D
	Ctrl-FN-D	Ctrl-FN-D
	FN-F5	FN-F5
	type from A:/IVGA/ CRT	type from A:/IVGA/ CRT
	FN-F12	FN-F12

Computer	Key command to activate port	Key command to de-activate port
AMS	FN-F2	FN-F2
AMT	setup screen	setup screen
AT&T	FN-F3 FN-F6	FN-F3 FN-F6
Advanced Logic Research	Ctrl-Alt-V	Ctrl-Alt-V
Altima	Shift-Ctrl-Alt-C setup VGA/ Conf.Simulscan	Shift-Ctrl-Alt-L setup VGA/ Conf.Simulscan
Ambra**	FN-F12 FN-F5 F2/Choose Option/ F5	FN-F12 FN-F5 F2/Choose Option/ F5
Amrel* **	setup menu Shift-Ctrl-D	setup menu Shift-Ctrl-D
Apple	see Mac Portable and Mac PowerBook	
Aspen	automatic	automatic
Award	FN-F6	FN-F6

Computer	Key command to activate port	Key command to de-activate port
BCC*	automatic	reboot computer
Bondwell	LCD or CRT options after bootup	reboot for LCD or CRT options to appear
Chaplet**	setup screen FN-F6 FN-F4	setup screen FN-F6 FN-F4
Chembook	FN-F6	FN-F6
Commax	Ctrl-Alt-#6	Ctrl-Alt-#5
Compaq* **	Ctrl-Alt-< FN-F4 automatic mode/? (for setup option)	Ctrl-Alt-> FN-F4 automatic mode/? (for setup option)
Compuadd* **	automatic Alt-F for screen setup option	automatic Alt-F for screen setup option
Data General	Ctrl-Alt-Command	Ctrl-Alt-Command

Computer	Key command to activate port	Key command to de-activate port
Data General Walkabout	2 CRT/X at DOS prompt	reboot
Datavue	Ctrl-Shift-M	Ctrl-Shift-M
DEC**	FN-F5 FN-F4	FN-F5 FN-F4
Dell**	Ctrl-Alt-< Ctrl-Alt-F10 FN-F8 (CRT/LCD) FN-D FN-F12	Ctrl-Alt-> Ctrl-Alt-F10 FN-F8 FN-D FN-F12
Digital*	automatic FN-F2	reboot FN-F2
Dolch	dip switch to CRT	dip switch to LCD
Epson	dip switch to CRT	dip switch to LCD
Everex*	setup screen option	setup screen option
For-A	Ctrl-Alt-Shift-C	Ctrl-Shift-Alt-L
Fujitsu	FN-F10	

Computer	Key command to activate port	Key command to de-activate port
Gateway	FN-F3 FN-F1/FN-F1 again simultaneous	FN-F3 FN-F1
Grid* **	FN-F2, choose auto or simultaneous Ctrl-Alt-Tab	FN-F2 Ctrl-Alt-Tab
Hitachi	FN-F7	FN-F7
Honeywell	FN-F10	FN-F10
Hyundai	setup screen option	setup screen option
IBM 970*	automatic	warm reboot
IBM ThinkPad**	reboot, enter setup menu FN-F7, select choice from setup menu FN-F1, select choice FN-F5, select choice	FN-F2

Computer	Key command to activate port	Key command to de-activate port
	PS/2 SC select choice (CRT, LCD, etc.)	
Infotel	FN-F12	FN-F12
Kaypro	boot up, monitor plugged in	unplug monitor
Kris Tech	FN-F8	FN-F8
Leading Edge	FN-T	FN-T
Mac Portable 100	no video port: not compatible	
Mac PowerBook 140, 145, 150, 170 160, 165, 180, 520, 540, 5300	no video port: requires a 3rd-party interface Control Panel folder, PowerBook Display folder; Activate Video Mirroring	warm reboot
210, 230, 250, 270, 280, 2300	requires Apple Docking Station or Mini Dock	

Computer	Key command to activate port	Key command to de-activate port
Magitronic	FN-F4	FN-F4
Mastersport	FN-F2	FN-F1
Micro Express*	automatic	warm reboot
Micron	FN-F2	FN-F2
Microslate*	automatic	warm reboot
Mitsubishi	SW2 On-Off-Off-Off	SW2 Off-On-On-On
NCR	setup screen option	setup screen option
NEC* **	setup screen option CRT at the DOS prompt FN-F3	setup screen option LCD at the DOS prompt FN-F3
Olivetti*	automatic FN-O/*	automatic FN-O/*
Packard Bell* **	FN-F0 Ctrl-Alt-<	FN-F0 Ctrl-Alt->

Computer	Key command to activate port	Key command to de-activate port
Panasonic	FN-F2	FN-F2
Prostar	Ctrl-Alt-S at bootup	Ctrl-Alt-S at bootup
Samsung*	setup screen option	setup screen option
Sanyo	setup screen option	setup screen option
Sharp	dip switch to CRT	dip switch to LCD
Sun SPARC-Dataview	Ctrl-Shift-M	Ctrl-Shift-M
Tandy**	Ctrl-Alt-Insert setup screen option	Ctrl-Alt-Insert setup screen option
Tangent	FN-F5	FN-F5
Texas Instruments*	setup screen option	setup screen option
Top-Link* **	setup screen option FN-F6	setup screen option FN-F6
Toshiba* **	Ctrl-Alt-End FN-End FN-F5	Ctrl-Alt-Home FN-Home FN-F5

Computer	Key command to activate port	Key command to de-activate port
	setup screen option	setup screen option
Twinhead*	FN-F7 FN-F5 Automatic	FN-F7 FN-F5 Automatic
WinBook	Ctrl-Alt-F10	Ctrl-Alt-F10
Wyse	software driven	software driven
Zenith**	FN-F10 FN-F2 FN-F1	FN-F10 FN-F2 FN-F1
Zeos**	Ctrl-Shift-D FN-F1	Ctrl-Shift-D FN-F1

* These manufacturers have models that automatically send video to the external CRT port when some type of display device is attached.

** These manufacturers offer more than one key command depending on the computer model

Appendix C

Using Video Mirroring with a PowerBook Computer

When you turn video mirroring (called SimulScan in newer PowerBooks-see below) on, the projector displays the same information that appears on your PowerBook's built-in screen. When video mirroring is off, the projector acts like a separate display.

To turn on video mirroring for the first time:

1. Open the Monitor's control panel; click on Monitor 2.
2. Set the number of colors you want.
3. Open the Control Strip; click on the monitor icon.
4. Select "Turn Video Mirroring On."

Now you can turn video mirroring on and off from the Control Strip without having to open the Monitor's control panel again.

When using video mirroring and high color graphics such as slide shows, the projected image occasionally might turn black and white. If this happens, perform the following steps:

1. Turn off video mirroring.
2. Open the Monitor's control panel.
3. Move the white menu bar to Monitor 2 to set the projector as the primary monitor.
4. Restart the PowerBook.

Using SimulScan

Some newer PowerBooks display images on an external monitor or projector differently than previous ones. When using SimulScan, the projector displays the same information that appears on your PowerBook.

To select SimulScan:

1. Open the Control Panel, then double-click Monitors and Sound.
2. In the Resolution list, choose the SimulScan mode, then click OK.
3. If this changes your display settings, a dialog box appears. Click OK to confirm the change.

Appendix D

Projected Image Size

Use this chart and tables to help you determine projected image sizes

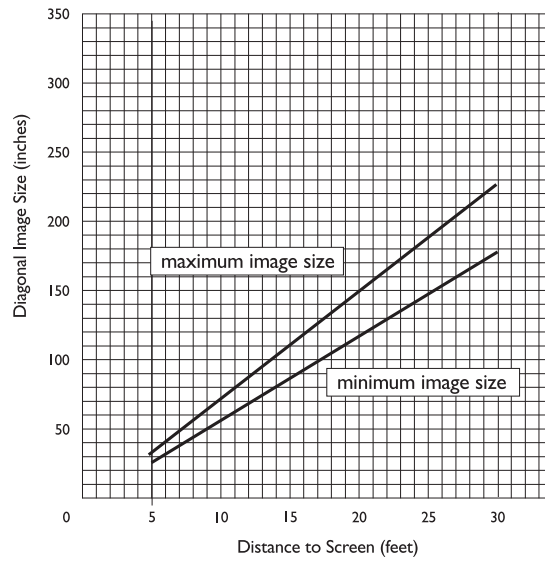

**Table 1:
Image Size, Width and Height for DP2000-maximum image size**

Distance to Screen	Diagonal	Width	Height
4.9 ft 1.5 m	3.2 ft .9 m	2.6 ft .8 m	1.9 ft .6 m
8 ft 2.4 m	5.2 ft 1.6 m	4.2 f 1.3 m	3.1 ft .9 m
12 ft 3.7 m	7.8 ft 2.4 m	6.3 ft 1.9 m	4.7 ft 1.4 m
16 ft 4.9 m	10.4 ft 3.1 m	8.3 ft 2.5 m	6.3 ft 1.9 m
20 ft 6 m	13.0 ft 3.9 m	10.4 ft 3.1 m	7.8 ft 2.4 m
30 ft 9 m	19.5 ft 5.9 m	15.6 ft 4.8 m	11.7 ft 3.6 m

**Table 2:
Image Size, Width and Height for DP2000-minimum image size**

Distance to Screen	Diagonal	Width	Height
4.9 ft 1.5 m	2.5 ft .8 m	2.0 ft .6 m	1.5 ft .4 m
8 ft 2.4 m	4.1 ft 1.25 m	3.3 ft 1 m	2.5 ft .7 m
12 ft 3.7 m	6.2 ft 1.9 m	4.9 ft 1.5 m	3.7 ft 1.1 m
16 ft 4.9 m	8.2 ft 2.5 m	6.6 ft 1.9 m	4.9 ft 1.5 m
20 ft 6 m	10.3 ft 3.1 m	8.2 ft 2.5 m	6.2 ft 1.9 m
30 ft 9 m	15.4 ft 4.7	12.3 ft 3.7 m	9.2 ft 2.8 m

Index

A

- activation commands for laptops 49
- adjusting
 - brightness 26
 - color 27
 - contrast 26
 - height 20
 - tint 27
 - volume 24, 27
- altitude limits 47
- assistance. See Technical Support
- Audio menu 27
 - Volume 27
- Auto Source Select 31

B

- Blank Screen 27
- brightness, adjusting 26
- buttons on keypad
 - Menu 24
 - Standby 24
 - Volume 24

C

- cable hub 12
- cables
 - A/V 15
 - composite video 15
 - hub connector 12
 - mouse 14
- cleaning the projection lens 37
- color
 - adjusting 27
- colors
 - don't match monitor colors 45

- not displayed 42
- compatibility
 - IBM-compatible 5
 - Macintosh 5
- composite video cable
 - connecting 15
- computers, compatible 5
- connecting
 - laptop 14
 - mouse 14
 - power cord 17
 - video player 15–16
- connector panel 12
- contrast, adjusting 26
- Controls menu 30
 - Auto Source Select 31
 - Default Source 31
 - Display Messages 32
 - Display Startup Screen 32
 - Plug and Play 32
 - Rear Projection 31
 - Standby Time 31
 - Video Standard 30
- customer support numbers 9

D

- Default Source 31
- dimensions 47
- Display menu options
 - Blank Screen 27
 - Brightness 26
 - Color 27
 - Contrast 26
 - Reset All 27
 - Tint 27

displaying
 messages 32
 on-screen menus 24
 startup screen 32

F

focus range 48
fuzzy lines 29

H

help
 customer support numbers 9
 fax 8
humidity 47

I

IBM-compatible computers
 compatibility 5
image
 adjusting 19
 centering 29
 colors don't match 45
 fuzzy lines 29
 has lines or spots 44
 not centered 42
 not displayed 42
 out of focus 43
 quality 42–45
 resolution 5
 reversed 31, 44
 size 11, 61
 streaked 44
 too wide or too narrow 43
 zooming 20
Image Manager 35
Image menu options 28
 Auto Image 28

Auto Resize 28
Horiz. Position 29
Manual Sync 29
Manual Tracking 29
Vert. Position 30

K

Kensington lock 41
keypad
 using 23
keypad buttons
 menu 24
 standby 24
 volume 24
KODAK Image Manager 35

L

lamp
 turns off unexpectedly 45
lamp hour counter 34
Language menu 33
language, selecting for menus 33
laptop activation sequence 49
lens
 cleaning 37

M

Macintosh computers
 compatibility 5
Menu button 25
menus. See on-screen menus
monitor, colors don't match 45
mouse, connecting 14

N

NTSC video 30

O

on-screen menus
 Audio menu 27
 changing functions 25
 changing language of 33
 Controls menu 30
 Display menu 26
 displaying 25
 Image menu 28
 Language menu 33
 Status menu 33

P

PAL video 27, 30
Plug and Play 32
power cord
 connecting 17
power up sequence 17, 43
project from behind the screen 31

R

rear projection 31
relative humidity 47
remote control
 operating the disk mouse 22
 using 21, 23
re-positioning image on screen 29
resetting adjustments 27
resolution 5

S

safety guidelines 1
SECAM video 27, 30
security feature 41
service numbers 9
setting up 11
SimulScan with PowerBooks 60

specifications 47
Standby button 24
Standby Time 31
startup screen 32
Status menu 33
support numbers 9
S-video, connecting 15

T

temperature limits 47
test pattern 43
text not visible 42
tint, adjusting 27
turning off the projector 18
turning on the projector 17

U

USB mouse 14

V

vertical lines displayed 29, 44
video 27
 mirroring PowerBook 59
video standards 30
volume
 adjusting 24

W

warranty 10, 67
weight 47

Z

zooming the image 20

WARRANTY TIME PERIOD

Kodak warrants the KODAK DIGITAL SCIENCE DP2000 Digital Projector (excluding lamps) to be free from malfunctions and defects in both materials and workmanship for two years from the date of purchase.

WARRANTY REPAIR COVERAGE

This warranty will be honored within the geographical location that the product was purchased.

If the equipment does not function properly during the warranty period due to defects in either materials or workmanship, Kodak will, at its option, either repair or replace the equipment without charge, subject to the conditions and limitations stated herein. Such repair will include all labor as well as any necessary adjustments and/or replacement parts.

If replacement parts are used in making repairs, these parts may be remanufactured, or may contain remanufactured materials. If it is necessary to replace the entire system, it may be replaced with a remanufactured system.

Kodak will also provide telephone assistance during the warranty period.

LIMITATIONS

WARRANTY SERVICE WILL NOT BE PROVIDED WITHOUT DATED PROOF OF PURCHASE.

THIS WARRANTY BECOMES NULL AND VOID IF YOU FAIL TO PACK YOUR DIGITAL PROJECTOR IN A MANNER CONSISTENT WITH THE ORIGINAL PRODUCT PACKAGING AND DAMAGE OCCURS DURING PRODUCT SHIPMENT.

THIS WARRANTY DOES NOT COVER: CIRCUMSTANCES BEYOND KODAK'S CONTROL; SERVICES OR PARTS TO CORRECT PROBLEMS RESULTING FROM THE USE OF ATTACHMENTS, ACCESSORIES, OR ALTERATIONS NOT MARKETED BY KODAK; SERVICE REQUIRED AS THE RESULT OF UNAUTHORIZED MODIFICATIONS OR SERVICE; MISUSE, ABUSE; FAILURE TO FOLLOW KODAK'S OPERATING, MAINTENANCE, OR REPACKAGING INSTRUCTIONS; OR FAILURE TO USE ITEMS SUPPLIED BY KODAK (SUCH AS ADAPTORS AND CABLES).

KODAK MAKES NO OTHER WARRANTIES, EXPRESS, IMPLIED, OR OF MERCHANTABILITY OR FITNESS FOR A PARTICULAR PURPOSE FOR THIS EQUIPMENT OR SOFTWARE.

REPAIR OR REPLACEMENT WITHOUT CHARGE ARE KODAK'S ONLY OBLIGATION UNDER THIS WARRANTY. KODAK WILL NOT BE RESPONSIBLE FOR ANY SPECIAL, CONSEQUENTIAL OR INCIDENTAL DAMAGES RESULTING FROM THE PURCHASE, USE, OR IMPROPER FUNCTIONING OF THIS EQUIPMENT REGARDLESS OF THE CAUSE. SUCH DAMAGES FOR WHICH KODAK WILL NOT BE RESPONSIBLE INCLUDE, BUT ARE NOT LIMITED TO, LOSS OF REVENUE OR PROFIT, DOWNTIME COSTS, LOSS OF USE OF THE EQUIPMENT, COST OF ANY SUBSTITUTE EQUIPMENT, FACILITIES OR SERVICES, OR CLAIMS OF YOUR CUSTOMERS FOR SUCH DAMAGES.

Depending on your geographical location, some limitations and exclusions may not apply.

Shipment of a unit from the customer to the kodak service center will be at the customer's expense.

This warranty is not transferable from the original purchaser of the equipment.

APPLICATION SUPPORT

For application specific support, contact your reseller, systems integrator, software manufacturer, or dealer.

HOW TO OBTAIN SERVICE

Please refer to the Service and Support section of your User's Guide for the support hotline designated to your location.

When returning a digital projector for repair, the unit shall be packed in its original packing materials. A problem report should also be enclosed with the equipment. If the original packaging has been discarded or is not available, packing will be at the owner's expense.

The repaired or replaced unit will be shipped from Kodak within five business days from the date of the digital projector receipt at the service center.

Unless a specific Kodak warranty is communicated to the purchaser in writing by a Kodak company, no other warranty or liability exists beyond the information contained above, even though defect, damage, or loss may be caused by negligence or other act.

To obtain warranty repair service contact your local Kodak representative. For assistance, refer to the Service and Support information in the KODAK Digital Projector User's Guide.

Eastman Kodak Company
343 State Street
Rochester, New York 14650

Kodak is a trademark of
Eastman Kodak Company.

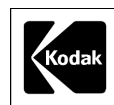

PN 3H7969
PN 010-0219-00

9/99

©Eastman Kodak Company

Printed in the U.S.A.

Free Manuals Download Website

<http://myh66.com>

<http://usermanuals.us>

<http://www.somanuals.com>

<http://www.4manuals.cc>

<http://www.manual-lib.com>

<http://www.404manual.com>

<http://www.luxmanual.com>

<http://aubethermostatmanual.com>

Golf course search by state

<http://golfingnear.com>

Email search by domain

<http://emailbydomain.com>

Auto manuals search

<http://auto.somanuals.com>

TV manuals search

<http://tv.somanuals.com>