

MDRIVE™ MOTOR+DRIVER

AC Plus

MICROSTEPPING OPERATING INSTRUCTIONS



MDRIVE 34™
MOTOR+DRIVER
AC Plus
MICROSTEPPING



MDRIVE 42™
MOTOR+DRIVER
AC Plus
MICROSTEPPING

MDriveAC Plus Motion Control Hardware Reference Change Log		
Date	Revision	Changes
03/07/2006	R030706	Initial Release
04/13/2006	R041306	Corrected Motor+Driver weight specification for MDM34AC Plus, added notes on recommended mating connector for the M23 19-pin connector P1. Added MD-CS10x-000 and MD-CS-20x-000 To Appendix C.
05/04/2006	R050406	Removed Ambient Temperature Specification
05/25/2006	R052506	Replaced USB to SPI Cable Driver Installation with instructions relevant to Windows XP Service Pack 2.
03/02/2007	R030207	Reworked IMS SPI Motor Interface Section, added information relevant to UL recognition. Added Enable Active High/Low parameter for SPI, changed temperature specification to: -40°C to +75°C (non-condensing humidity), measured at the heat sink, and -40°C to +90°C (non-condensing humidity), measured on the motor.
12/17/2007	R121707	Minor updates and corrections. Made relevant to Firmware Version 3.0.02. Added Appendix for size 34 Linear slide.

Low Voltage Installation Information

Certain practices must be followed when installing the AC motor drives in order to meet the requirements of the Low Voltage Directive 73/23/EEC and as amended by Directive 93/68/EEC. The AC motor drives are components intended for installation within other electrical systems or machines. The system or machine builder must ensure their product complies with the applicable standards required for that equipment. The following information applies to the AC motor drives as far as the Low Voltage Directive is concerned.

- 1) The AC motor drives are designed to be installed in a pollution degree level 2 environment.
- 2) All control inputs and outputs are isolated from AC power with a basic insulation rating. The minimum clearance and creepage distance on the printed wiring board from the AC input to the control inputs and outputs is 3 millimeters. This is representative of an impulse rating of 4 KV (1.2/50 us) as referenced in standard EN50178.
- 3) The control inputs and outputs may require an additional level of protection against direct contact if such protection is required by the standards governing the overall system or machine and its intended environment. It is the machine builder's responsibility to provide this protection if needed.
- 4) Be sure to wire the AC power and earth ground connection as shown in the operator's manual.
- 5) All cautions and warnings listed throughout the operator's manual must be followed to insure safe system operation.

UL Application Details and Conditions of Acceptance

The UL Application Details and Conditions of Acceptance are located on the web at http://www.imshome.com/CE_conformity.html.

The information in this book has been carefully checked and is believed to be accurate; however, no responsibility is assumed for inaccuracies.

Intelligent Motion Systems, Inc., reserves the right to make changes without further notice to any products herein to improve reliability, function or design. Intelligent Motion Systems, Inc., does not assume any liability arising out of the application or use of any product or circuit described herein; neither does it convey any license under its patent rights of others. Intelligent Motion Systems and  are trademarks of Intelligent Motion Systems, Inc.

Intelligent Motion Systems, Inc.'s general policy does not recommend the use of its products in life support or aircraft applications wherein a failure or malfunction of the product may directly threaten life or injury. Per Intelligent Motion Systems, Inc.'s terms and conditions of sales, the user of Intelligent Motion Systems, Inc., products in life support or aircraft applications assumes all risks of such use and indemnifies Intelligent Motion Systems, Inc., against all damages.

MDriveAC Plus Microstepping
Revision R121707
Copyright © Intelligent Motion Systems, Inc.
All Rights Reserved



Getting Started: MDriveAC Plus Microstepping.....1-1
 Before You Begin..... 1-1
 Connecting AC Power..... 1-1
 Connect Opto Power and Logic Inputs 1-1
 Connecting Parameter Setup Cable..... 1-2
 Install the IMS SPI Motor Interface 1-2

Part 1: Hardware Specifications

Section 1.1: Introduction to the MDrive34AC Plus Microstepping.....1-5
 Configuring 1-5
 Features and Benefits..... 1-5

Section 1.2: MDrive34AC Plus Microstepping Detailed Specifications.....1-7
 General Specifications 1-7
 Setup Parameters 1-8
 Mechanical Specifications..... 1-9
 Pin Assignment and Description 1-10
 P1 19-Pin M23 Connector - I/O and SPI Communications..... 1-10
 P1 19-Pin M23 Connector - I/O, SPI Communications with Encoder Interface Option1-11
 P3 Connector - AC Power..... 1-12
 Internal Encoder 1-12
 Control Knob 1-12
 Planetary Gearbox..... 1-12
 Parameter Setup Cable and Adapter 1-12
 Cordsets..... 1-12

Section 1.3: Introduction to the MDrive42AC Plus Microstepping.....1-13
 Configuring 1-13
 Features and Benefits..... 1-13

Section 1.4: MDrive42AC Plus Microstepping Detailed Specifications.....1-15
 Setup Parameters 1-16
 Pin Assignment and Description 1-18
 P1 19-Pin M23 Connector - I/O and SPI Communications..... 1-18
 P1 19-Pin M23 Connector - I/O, SPI Communications with Encoder Interface Option1-19
 P3 Connector - AC Power..... 1-20
 Internal Encoder 1-21
 Control Knob 1-21
 Parameter Setup Cable and Adapter 1-21
 Cordsets..... 1-21

Part 2: Interfacing and Configuration

Section 2.1: Logic Interface and Connection2-3
 Optically Isolated Logic Inputs..... 2-3
 Isolated Logic Input Pins and Connections 2-3
 Isolated Logic Input Characteristics..... 2-4
 Enable Input 2-4
 Clock Inputs..... 2-4
 Optocoupler Reference..... 2-6
 Input Connection Examples..... 2-7
 Open Collector Interface Example 2-7
 Switch Interface Example 2-8
 Fault Output..... 2-8
 Minimum Required Connections..... 2-9

Section 2.2: Connecting SPI Communications2-10
 Connecting the SPI Interface 2-10
 SPI Signal Overview..... 2-10
 SPI Pins and Connections 2-11
 SPI Master with Multiple MDriveAC Plus Microstepping 2-11

Section 2.3: Using the IMS SPI Motor Interface.....	2-12
Installation	2-12
Configuration Parameters and Ranges	2-12
Color Coded Parameter Values	2-12
IMS SPI Motor Interface Menu Options.....	2-13
Screen 1: The Motion Settings Configuration Screen	2-15
MSEL (Microstep Resolution Selection)	2-15
HCDT (Hold Current Delay Time)	2-16
MRC (Motor Run Current)	2-16
MHC (Motor Hold Current).....	2-16
DIR (Motor Direction).....	2-16
User ID.....	2-16
IMS SPI Motor Interface Button Functions	2-16
Screen 2: I/O Settings Configuration Screen	2-17
Input Clock Type	2-17
Input Clock Filter	2-17
Enable Active High/Low	2-17
Warning Temperature	2-17
IMS Part Number/Serial Number Screen	2-18
Fault Indication.....	2-18
Upgrading the Firmware in the MDriveAC Plus Microstepping.....	2-19
The IMS SPI Upgrader Screen.....	2-19
Upgrade Instructions.....	2-19
Initialization Screen.....	2-20
Port Menu.....	2-20
Section 2.4: Using User-Defined SPI.....	2-21
SPI Timing Notes.....	2-21
Check Sum Calculation for SPI.....	2-21
SPI Commands and Parameters.....	2-22
SPI Communications Sequence	2-23

Appendices

Appendix A: MDriveAC Plus Microstepping Motor Performance	A-3
MDrive34AC Plus Microstepping.....	A-3
Speed-Torque Curves	A-3
Motor Specifications	A-3
MDrive42AC Plus Microstepping.....	A-4
Speed-Torque Curves	A-4
Motor Specifications	A-5
Appendix B: MDrive with Planetary Gearbox	A-6
Section Overview	A-6
Product Overview	A-6
Selecting a Planetary Gearbox.....	A-6
Calculating the Shock Load Output Torque (TAB)	A-7
System Inertia	A-10
Planetary Gearbox for MDrive34AC Plus2	A-14
PM81 Gearbox Ratios and Part Numbers	A-14
Planetary Gearbox for MDrive42AC Plus2	A-15
PM105 Gearbox Ratios and Part Numbers	A-15
PM120 Gearbox Ratios and Part Numbers	A-16
Appendix C: Optional Cables and Cordsets.....	A-17
MD-CC300-000: USB to SPI Parameter Setup Cable	A-17
Installation Procedure for the MX-CC300-000	A-17
Installing the Cable/VCP Drivers.....	A-17
Determining the Virtual COM Port (VCP)	A-19
Adapter	A-20
MD-CS10x-000 Cordset.....	A-21
Pin Assignment and Wire Colors	A-21
MD-CS20x-000 Cordset.....	A-22

Appendix D: Interfacing the Internal Differential Optical Encoder	A-23
Factory Mounted Encoder.....	A-23
General Specifications	A-23
Pin Configuration	A-23
Encoder Signals.....	A-24
Appendix E: Linear Slide Option	A-25
Features.....	A-25
MDrive32Plus Linear Slide	A-25
Speed Force Limitations.....	A-25
Speed-Torque Curves	A-25
Specifications	A-26
Mechanical Specifications	A-26

List Of Figures

Figure GS.1: Minimum Logic and Power Connections	1-1
Figure GS.2: MDriveAC Plus CD.....	1-2
Figure GS.3: IMS Motor Interface Showing Default Settings.....	1-2

Part 1: Hardware Specifications

Figure 1.1.1: MDrive34AC Plus Microstepping	1-5
Figure 1.2.1: MDrive34AC Plus Mechanical Specifications.....	1-9
Figure 1.2.2: P1 Connector, Power and I/O	1-12
Figure 1.2.3: P3 3-Pin Euro AC Connector.....	1-12
Figure 1.3.1: MDrive42AC Plus Microstepping	1-13
Figure 1.4.1: MDrive42AC Plus Mechanical Specifications.....	1-17
Figure 1.4.2: P1 Connector, Power and I/O	1-20
Figure 1.4.3: P3 3-Pin Euro AC Connector.....	1-20

Part 2: Interfacing and Configuration

Figure 2.1.1: Isolated Logic Pins and Connections	2-3
Figure 2.2.1: MDriveAC Plus Microstepping Block Diagram.....	2-3
Figure 2.1.2: Input Clock Functions	2-4
Figure 2.1.3: Clock Input Timing Characteristics.....	2-5
Figure 2.1.4: Optocoupler Input Circuit Diagram.....	2-6
Figure 2.1.5: Open Collector Interface Example.....	2-7
Figure 2.1.6: Switch Interface Example	2-8
Figure 2.1.7: Fault Output interfaced to an LED	2-9
Figure 2.1.8 Minimum Required Connections.....	2-9
Figure 2.2.1: MD-CC300-000 Parameter Setup Cable.....	2-10
Figure 2.2.2: SPI Pins and Connections, 10-Pin IDC.....	2-11
Figure 2.2.4: SPI Master with a Single MDriveAC Plus Microstepping.....	2-11
Figure 2.2.5: SPI Master with Multiple MDriveAC Plus Microsteppings	2-11
Figure 2.3.1: SPI Motor Interface Color Coding.....	2-13
Figure 2.3.3: SPI Motor Interface View Menu.....	2-13
Figure 2.3.2: SPI Motor Interface File Menu	2-13
Figure 2.3.4: SPI Motor Interface Recall Menu	2-14
Figure 2.3.5: SPI Motor Interface Upgrade Menu	2-14
Figure 2.3.6: SPI Motor Interface Help Menu and About Screen	2-14
Figure 2.3.7: SPI Motor Interface Motion Settings Screen.....	2-15
Figure 2.3.8: SPI Motor Interface I/O Settings Screen.....	2-17
Figure 2.3.9: SPI Motor Interface Part and Serial Number Screen	2-18
Figure 2.3.10: SPI Motor Interface Upgrade Utility	2-19
Figure 2.3.11: SPI Motor Interface Initialization	2-20
Figure 2.3.12: SPI Motor Interface Port Menu	2-20
Figure 2.4.1: SPI Timing.....	2-21
Figure 2.4.2: Read/Write Byte Order for Parameter Settings (Default Parameters Shown)	2-23

Appendices

Figure A.1: MDrive34AC Plus 120VAC Microstepping Speed-Torque Curves.....	A-3
Figure A.2: MDrive34AC Plus 240VAC Microstepping Speed-Torque Curves.....	A-3
Figure A.3: MDrive42AC Plus 120VAC Microstepping Speed-Torque Curves.....	A-4
Figure A.4: MDrive42AC Plus 240VAC Microstepping Speed-Torque Curves.....	A-4
Figure B.1: MDrive23 Torque-Speed Curve	A-8

Figure B.2: Lead Screw System Inertia Considerations	A-10
Figure B.3: Rack and Pinion System Inertia Considerations	A-11
Figure B.4: Conveyor System Inertia Considerations.....	A-11
Figure B.5: Rotary Table System Inertia Considerations	A-12
Figure B.6: Chain Drive System Inertia Considerations.....	A-13
Figure B.7: Planetary Gearbox Specifications for MDrive34AC Plus ²	A-14
Figure B.8: PM105 Planetary Gearbox Specifications for MDrive42AC Plus ²	A-15
Figure B.9: PM120 Planetary Gearbox Specifications for MDrive42AC Plus ²	A-16
Figure C.2: MD-CC300-000 Mechanical Specifications	A-17
Figure C.1: MD-CC300-000	A-17
Figure C.3: Hardware Update Wizard	A-17
Figure C.4: Hardware Update Wizard Screen 2	A-18
Figure C.5: Hardware Update Wizard Screen 3	A-18
Figure C.6: Windows Logo Compatibility Testing.....	A-18
Figure C.8: Hardware Properties	A-19
Figure C.7: Hardware Update Wizard Finish Installation	A-19
Figure C.9: Windows Device Manager.....	A-19
Figure C.10: Typical Setup, Adapter and Single-End Cordset	A-20
Figure C.11: MD-ADP-M23	A-20
Figure C.12: MD-ADP-M23 Mechanical Specifications	A-20
Figure C.13: MD-CS10x-000 Prototype Development Cordset.....	A-21
Figure C.14: MD-CS20x-000	A-22
Figure D.1: Internal Differential Encoder Pin Configuration	A-23
Figure D.2: Differential Encoder Signal Timing	A-24
Figure E.1: Speed-Force Limitations.....	A-25
Figure E.2: Speed-Torque Curves	A-25
Figure E.3: Mechanical Specifications.....	A-26

List of Tables

Table GS.1: AC Wire Colors	1-1
----------------------------------	-----

Part 1: Hardware Specifications

Table 1.2.1: Setup Parameters.....	1-8
Table 1.2.2: P1- 19-Pin M23 Pin Assignment and Description	1-10
Table 1.2.3: P1- 19-Pin M23 Pin Assignment and Description (Internal Optical Encoder).....	1-11
Table 1.2.4: P3 - AC Power	1-12
Table 1.4.1: Setup Parameters.....	1-16
Table 1.4.2: P1- 19-Pin M23 Pin Assignment and Description	1-18
Table 1.4.3: P1- 19-Pin M23 Pin Assignment and Description (Internal Optical Encoder).....	1-19
Table 1.4.4: P3 - AC Power	1-20

Part 2: Interfacing and Configuration

Table 2.1.1: Input Clocks Timing Table	2-5
Table 2.1.2: Optocoupler Reference Connection.....	2-6
Table 2.1.3: Fault Output Specifications	2-8
Table 2.3.1: Setup Parameters and Ranges.....	2-12
Table 2.3.2: Microstep Resolution Settings.....	2-15
Table 2.3.4: Input Clock Filter Settings.....	2-17
Table 2.4.1: SPI Commands and Parameters	2-22

Appendices

Table B.1: Planetary Gearbox Operating Factor.....	A-9
Table B.2: Planetary Gearbox Specifications – PM81	A-14
Table B.3: Planetary Gearbox Ratios and Part Numbers	A-14
Table B.4: Planetary Gearbox Specifications – PM105	A-15
Table B.5: PM105 Planetary Gearbox Ratios, Inertia Moments and Part Numbers	A-15
Table B.7: PM120 Planetary Gearbox Ratios, Inertia Moments and Part Numbers	A-16
Table B.6: Planetary Gearbox Specifications – PM120	A-16
Table C.1: MD-CS10x-000 Wire Color Chart.....	A-21
Table C.2: Euro AC Wire Color Chart.....	A-22
Table D1: Available Encoder Line Counts and Part Numbers.....	A-23
Table E.1: Linear Slide Specifications	A-26

GETTING STARTED

MDriveAC Plus Microstepping



WARNING!
The MDrive has components which are sensitive to Electrostatic Discharge (ESD). All handling should be done at an ESD protected workstation.

Before You Begin

The Quick Start guide is designed to help quickly connect and begin using your MDriveAC Plus Microstepping integrated motor and driver. The following examples will help you get the motor turning for the first time and introduce you to the basic settings of the drive.

Tools and Equipment Required

- MDriveAC Plus Microstepping Unit.
- Parameter setup cable MD-CC300-000 and Adapter MD-ADP-M23 or equivalent (USB to SPI).
- Product CD or Internet access to www.imshome.com.
- Control Device for Step/Direction.
- +5 to +24 VDC optocoupler supply.
- Basic Tools: Wire Cutters / Strippers / Screwdriver.
- Wiring/Cabling for AC Power and Logic Connections (See Note in page margin).
- A PC with Windows XP Service Pack 2.



Note: UL Recognition requires the use of the MD-CS20x-000 or Lumberg Equivalent AC Power Cordset.

Connecting AC Power

AC Power to Connector P3.

AC Power To P3			
P3	Function	US Color	Euro Color
1	Earth GND	Green	Green/Yellow
2	AC Line	Black	Brown
3	AC Neutral	White	Blue

Table GS.1: AC Wire Colors

Connect Opto Power and Logic Inputs

Using the recommended wire (see the specifications for your MDriveAC Plus), connect the DC output of the optocoupler power supply to the P1, Pin 1 of your MDriveAC Plus Microstepping model.

Connect the opto supply ground to the Power Ground pin appropriate for your controller/control circuitry.

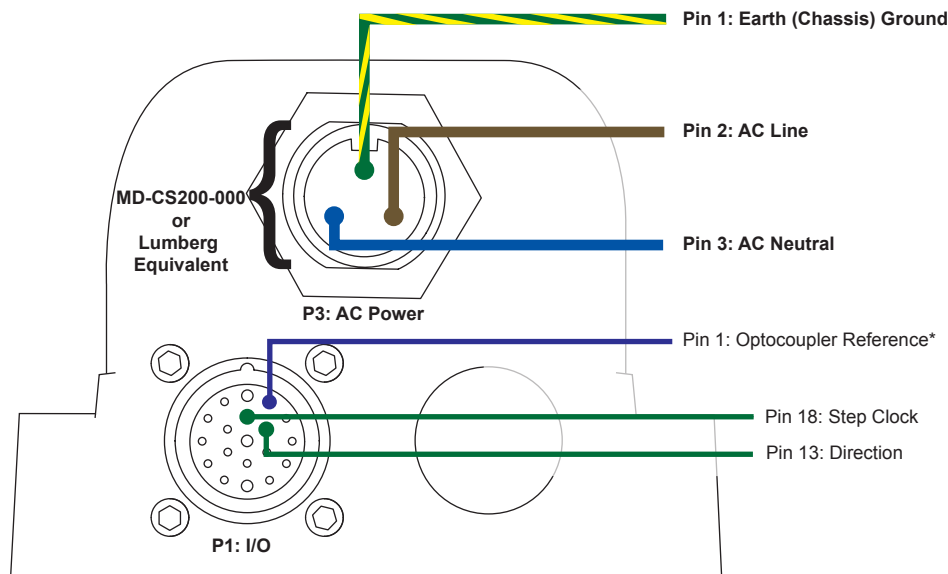

*Optocoupler Reference = +5 to +24 VDC: Sinking Inputs
*Optocoupler Reference = GND: Sourcing Inputs

Figure GS.1: Minimum Logic and Power Connections



WARNING!
Because the MDrive consists of two core components, a drive and a motor, close attention must be paid to the thermal environment where the device is used. See Thermal Specifications.

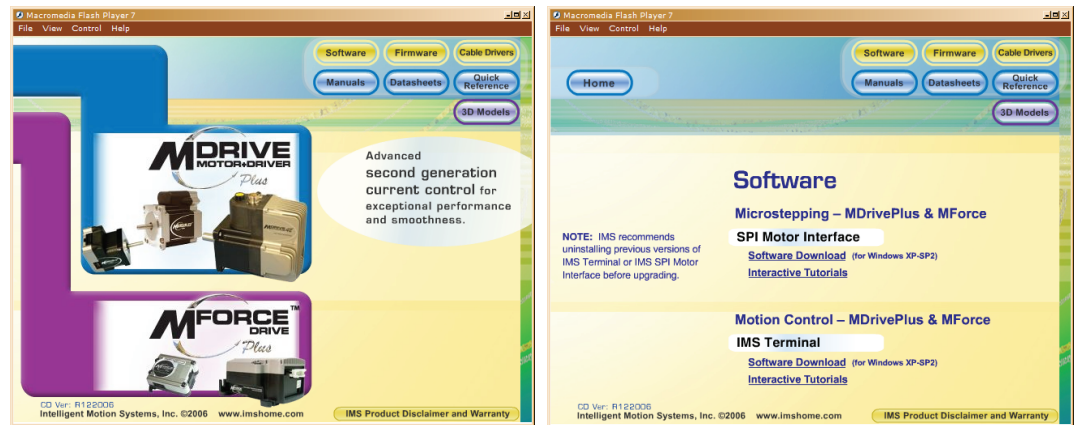

Figure G.S.2: MDriveAC Plus CD

Connecting Parameter Setup Cable

Connect the Host PC to the MDriveAC Plus Microstepping using the IMS Parameter Setup Cable or equivalent.

Install the IMS SPI Motor Interface

The IMS SPI Motor Interface is a utility that easily allows you to set up the parameters of your MDriveAC Plus Microstepping. It is available both on the MDriveAC Plus CD that came with your product and on the IMS web site at http://www.imshome.com/software_interfaces.html.

1. Insert the CD into the CD Drive of your PC. If the CD is not available, go to http://www.imshome.com/software_interfaces.html.
2. The CD will auto-start.
3. Click the Software Button in the top-right navigation Area.
4. Click the IMS SPI Interface link appropriate to your operating system.
5. Click SETUP in the Setup dialog box and follow the on-screen instructions.
6. Once IMS SPI Motor Interface is installed, the MDriveAC Plus Microstepping settings can be checked and/or set.

Once installed you can change the motor run current, holding current, microstep resolution and other configuration settings. By sending clock pulses to the drive you can now change these settings safely on the fly as the IMS SPI Motor interface will not allow you to set an out of range value.

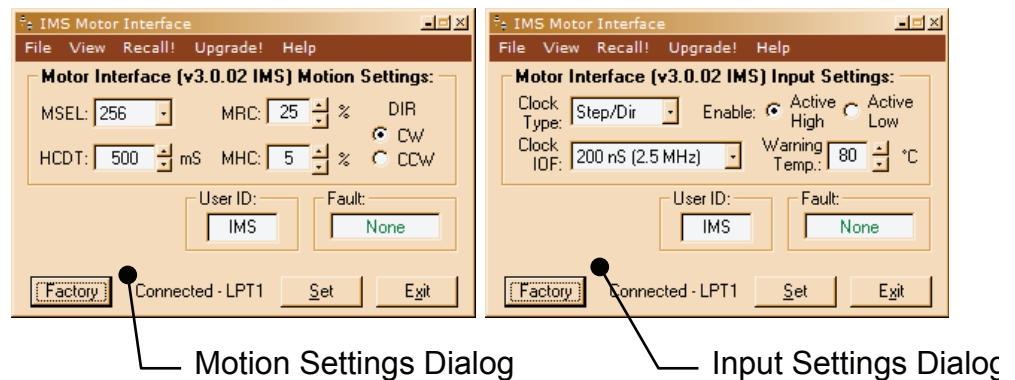
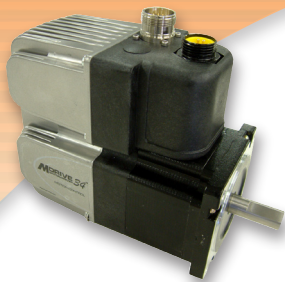

Figure G.S.3: IMS Motor Interface Showing Default Settings



MDRIVE™
MOTOR+DRIVER
AC Plus
MICROSTEPPING

**PART 1:
HARDWARE
SPECIFICATIONS**

Section 1.1: MDrive34AC Plus Microstepping Product Introduction

Section 1.2: MDrive34CAC Plus Microstepping Detailed Specifications

Section 1.3: MDrive42AC Plus Microstepping Product Introduction

Section 1.4: MDrive42AC Plus-65 Microstepping Detailed Specifications



SECTION 1.1

Introduction to the MDrive34AC Plus Microstepping

The MDrive34AC Plus Microstepping high torque integrated motor and driver is ideal for designers who want the simplicity of a motor with on-board electronics. The integrated electronics of the MDrive34AC Plus eliminate the need to run motor cabling through the machine, reducing the potential for problems due to electrical noise.

The unsurpassed smoothness and performance delivered by the MDrive34AC Plus Microstepping are achieved through IMS's advanced 2nd generation current control. By applying innovative techniques to control current flow through the motor, resonance is significantly dampened over the entire speed range and audible noise is reduced.

The MDrive34AC Plus accepts a broad input voltage range from 95 to 264 VAC, delivering enhanced performance and speed. Oversized input capacitors are used to minimize power line surges, reducing problems that can occur with long runs and multiple drive systems. An extended operating range of -40° to $+85^{\circ}\text{C}$ provides long life, trouble free service in demanding environments.

The MDrive34AC Plus uses a NEMA 34 frame size high torque brushless motor combined with a microstepping driver, and accepts up to 20 resolution settings from full to 256 microsteps per full step, including: degrees, metric and arc minutes. These settings may be changed on-the-fly or downloaded and stored in nonvolatile memory with the use of a simple GUI which is provided. This eliminates the need for external switches or resistors. Parameters are changed via an SPI port.

For use in environments where exposure to dust and liquids may occur, a sealed MDrive34AC Plus Microstepping unit with circular connectors meets IP65 specifications.

The versatile MDrive34AC Plus Microstepping is available in multiple configurations to fit various system needs. Three rotary motor lengths are available as are optional: internal optical encoder; control knob for manual positioning; integrated planetary gearbox. A long life Acme screw linear actuator version is also available. Interface connections are accomplished using standard industrial connectors.

The MDrive34AC Plus is a compact, powerful and inexpensive solution that will reduce system cost, design and assembly time for a large range of brushless motor applications.



Figure 1.1.1: MDrive34AC Plus Microstepping Integrated Motor, Power Supply, and Drive Electronics

Configuring

The IMS Motor Interface software is an easy to install and use GUI for configuring the MDrive34AC Plus from a computer's USB port. GUI access is via the IMS SPI Motor Interface included on the CD shipped with the product, or from www.imshome.com. Optional cables are available for ease of connecting and configuring the MDrive.

The IMS SPI Motor Interface features:

- Easy installation.
- Automatic detection of MDrive version and communication configuration.
- Will not set out-of-range values.
- Tool-tips display valid range setting for each option.
- Simple screen interfaces.

Features and Benefits

- Highly Integrated Microstepping Driver and NEMA 34 High Torque Brushless Motor
- Advanced 2nd Generation Current Control for Exceptional Performance and Smoothness
- Single Supply: 120 or 240 VAC
- Low Cost
- Extremely Compact

- 20 Microstep Resolutions up to
 - 51,200 Steps Per Rev Including:
 - Degrees, Metric, Arc Minutes
- Optically Isolated Logic Inputs will
 - Accept +5 to +24 VDC Signals,
 - Sourcing or Sinking
- Automatic Current Reduction
- Configurable:
 - Motor Run/Hold Current
 - Motor Direction vs. Direction Input
 - Microstep Resolution
 - Clock Type: Step and Direction, Quadrature, Step Up and Step Down
 - Programmable Digital Filtering for Clock and Direction Inputs
- Available Options:
 - Internal Differential Optical Encoder
 - Integrated Planetary Gearbox
 - Control Knob for Manual Positioning
 - IP65 Sealed Configuration
- 3 Rotary Motor Lengths Available
- Current and Microstep Resolution May Be Switched On-The-Fly
- Interface Options:
 - Circular 19-Pin M23
 - Circular 3-Pin Euro AC
- Graphical User Interface (GUI) for Quick and Easy Parameter Setup

SECTION 1.2

MDrive34AC Plus Microstepping Detailed Specifications



WARNING!
Because the MDrive consists of two core components, a drive and a motor, close attention must be paid to the thermal environment where the device is used. See Thermal Specifications.

General Specifications

Electrical Specifications

Input Voltage (+VAC) Range (120 VAC MDrive)	95 to 132 VAC @ 50/60 Hz
Input Current (120 VAC MDrive)	4.2 A Maximum
Input Voltage (+VAC) Range (240 VAC MDrive)	95 to 264 VAC @ 50/60 Hz
Input Current (240 VAC MDrive)	2.1 A Maximum

Thermal Specifications

Heat Sink Temperature (non-condensing)	-40°C to +75°C
Motor Temperature (non-condensing)	-40°C to +90°C

I/O Specifications

Isolated Inputs — Step Clock, Direction and Enable

Resolution	10 Bit
Voltage Range (Sourcing or Sinking)	+5 to +24 VDC
Current (+5 VDC Max)	8.7 mA
Current (+24 VDC Max)	14.6 mA

Communications Specifications

Protocol	SPI
----------	-----

Motion Specifications

Microstep Resolution

Number of Resolutions	20
-----------------------	----

Available Microsteps Per Revolution									
200	400	800	1000	1600	2000	3200	5000	6400	10000
12800	20000	25000	25600	40000	50000	51200	36000 ¹	21600 ²	25400 ³

1=0.01 deg/ μ step 2=1 arc minute/ μ step 3=0.001 mm/ μ step

Digital Filter Range	50 nS to 12.9 μ S (10 MHz to 38.8kHz)
Clock Types	Step/Direction, Quadrature, Clock Up/Clock Down
Step Frequency (Max)	5.0 MHz
Step Frequency Minimum Pulse Width	100 nS

Motor Specifications	
Single Length	
Holding Torque	330 oz-in/233 N-cm
Detent Torque	10.9 oz-in/7.7 N-cm
Rotor Inertia	0.01416 oz-in-sec ² /1.0 kg-cm ²
Weight (Motor + Driver)	3.8 lb/2.9 kg
Double Length	
Holding Torque	500 oz-in/353 N-cm
Detent Torque	14.16 oz-in/10.0 N-cm
Rotor Inertia	0.02266 oz-in-sec ² /1.6 kg-cm ²
Weight (Motor + Driver)	5.2 lb/3.5 kg
Triple Length	
Holding Torque	750 oz-in/529 N-cm
Detent Torque	19.83 oz-in/10.0 N-cm
Rotor Inertia	0.04815 oz-in-sec ² /3.4 kg-cm ²
Weight (Motor + Driver)	8.6 lb/5.0 kg

Setup Parameters

The following table illustrates the setup parameters. These are easily configured using the IMS SPI Motor Interface configuration utility. An optional Parameter Setup Cable is available and recommended with the first order.

MDriveAC Plus Microstepping Setup Parameters				
Name	Function	Range	Units	Default
MHC	Motor Hold Current	0 to 100	percent	5
MRC	Motor Run Current	1 to 100	percent	25
MSEL	Microstep Resolution	1, 2, 4, 5, 8, 10, 16, 25, 32, 50, 64, 100, 108, 125, 127, 128, 180, 200, 250, 256	μsteps per full step	256
DIR	Motor Direction Override	0/1	—	CW
HCDT	Hold Current Delay Time	0 or 2-65535	mSec	500
CLK TYPE	Clock Type	Step/Dir. Quadrature, Up/Down	—	Step/Dir
CLK IOF	Clock and Direction Filter	50 nS to 12.9 μS (10 MHz to 38.8 kHz)	nS (MHz)	200 nS (2.5 MHz)
USER ID	User ID	1-3 characters	Viewable ASCII	IMS
WARN TEMP	Warning Temperature	0 to 125	Degrees Celsius	80
EN ACT	Enable Active State	High/Low	—	High

Table 1.2.1: Setup Parameters

Mechanical Specifications

Dimensions in Inches (mm)

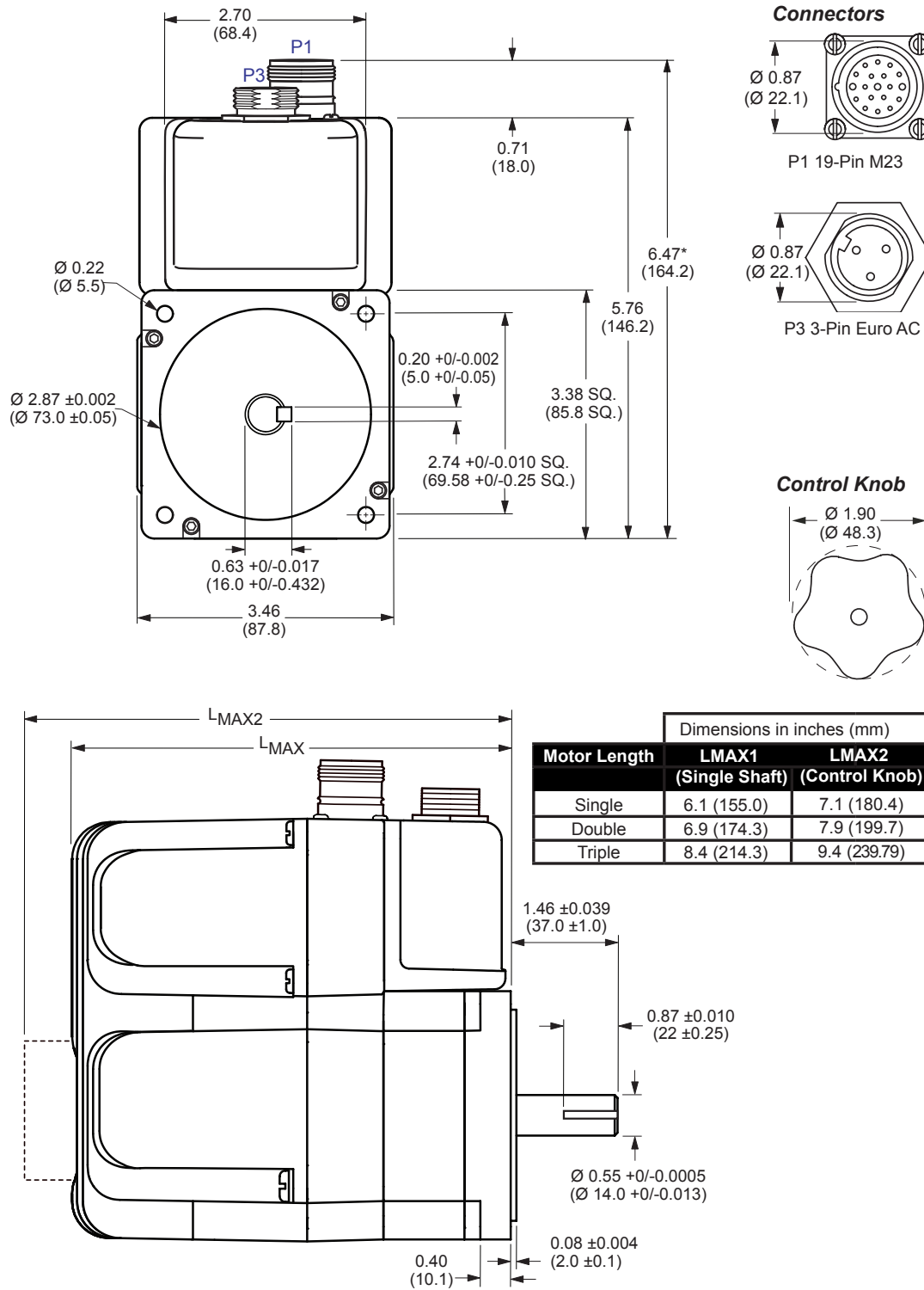

Figure 1.2.1: MDrive34AC Plus Mechanical Specifications

Pin Assignment and Description

P1 19-Pin M23 Connector - I/O and SPI Communications



NEED A CABLE?

The following cordset is available to interface to the 19-Pin M23 Connector:

Straight Termination
MD-CS100-000

Right Angle Termination
MD-CS-101-000

See Appendix E for details.

Pin Assignment - P1 I/O and SPI Connections		
Pin #	Function	Description
Pin 1	Opto Reference	The signal applied to the Optocoupler Reference will determine the sinking/ or sourcing configuration of the inputs. To set the inputs for sinking operation, a +5 to +24 VDC supply is connected. If sourcing, the Reference is connected to Ground.
Pin 2	Enable	Enable/Disable Input will enable or disable the driver output to the motor. In the disconnected state the driver outputs are enabled in either sinking or sourcing configuration.
Pin 3	N/C	No Connect.
Pin 4	N/C	No Connect.
Pin 5	N/C	No Connect.
Pin 6	N/C	No Connect.
Pin 7	N/C	No Connect.
Pin 8	MOSI	Master-Out/Slave-In. Carries output data from the SPI Master
Pin 9	CS	SPI Chip Select. This signal is used to turn communications on multiple MDM units on or off.
Pin 10	+5 VDC Output	Supply voltage for the MD-CC300-000 Cable ONLY!
Pin 11	GND	Communications Ground.
Pin 12	N/C	No Connect.
Pin 13	Direction/Channel B/ Clock Down	Direction input. The axis direction will be with respect to the state of the Direction Override Parameter. It may also receive quadrature and clock up type inputs if so configured.
Pin 14	N/C	No Connect.
Pin 15	N/C	No Connect.
Pin 16	SPI Clock	The Clock is driven by the SPI Master. The clock cycles once for each data bit.
Pin 17	MISO	Master-In/Slave-Out. Carries output data from the MDM back to the SPI Master.
Pin 18	Step Clock/Channel A/ Clock Up	Step Clock input. The step clock input will receive the clock pulses which will step the motor 1 step for each pulse. It may also receive quadrature and clock up type inputs if so configured.
Pin 19	Fault Output	Open-Drain pending Over-temperature and Over-temperature Fault. When device reaches the temperature specified by the warning temperature the output will pulse at 1 second intervals. When in Over-temperature fault the output will be active continually.
Recommended Cordset		
MD-CS100-000 or MD-CS101-000		

Table 1.2.2: P1- 19-Pin M23 Pin Assignment and Description

P1 19-Pin M23 Connector - I/O, SPI Communications with Encoder Interface Option

Pin Assignment - P1 I/O, SPI and Encoder Connections		
Pin #	Function	Description
Pin 1	Opto Reference	The signal applied to the Optocoupler Reference will determine the sinking/ or sourcing configuration of the inputs. To set the inputs for sinking operation, a +5 to +24 VDC supply is connected. If sourcing, the Reference is connected to Ground.
Pin 2	Enable	Enable/Disable Input will enable or disable the driver output to the motor. In the disconnected state the driver outputs are enabled in either sinking or sourcing configuration.
Pin 3	Index +	Encoder Index + Output.
Pin 4	Channel B +	Encoder Channel B + Output.
Pin 5	Channel B –	Encoder Channel B – Output.
Pin 6	N/C	No Connect.
Pin 7	Channel A +	Encoder Channel A + Output.
Pin 8	MOSI	Master-Out/Slave-In. Carries output data from the SPI Master
Pin 9	CS	SPI Chip Select. This signal is used to turn communications on multiple MDM units on or off.
Pin 10	+5 VDC Output	Supply voltage for the MD-CC300-000 Cable ONLY!
Pin 11	GND	Communications Ground.
Pin 12	N/C	No Connect.
Pin 13	Direction/Channel B/ Clock Down	Direction input. The axis direction will be with respect to the state of the Direction Override Parameter. It may also receive quadrature and clock up type inputs if so configured.
Pin 14	Index –	Encoder Index – Output.
Pin 15	Channel A –	Encoder Channel A – Output.
Pin 16	SPI Clock	The Clock is driven by the SPI Master. The clock cycles once for each data bit.
Pin 17	MISO	Master-In/Slave-Out. Carries output data from the MDM back to the SPI Master.
Pin 18	Step Clock/Channel A/ Clock Up	Step Clock input. The step clock input will receive the clock pulses which will step the motor 1 step for each pulse. It may also receive quadrature and clock up type inputs if so configured.
Pin 19	Fault Output	Open-Drain pending Over-temperature and Over-temperature Fault. When device reaches the temperature specified by the warning temperature the output will pulse at 1 second intervals. When in Over-temperature fault the output will be active continually.
Recommended Cordset		
MD-CS100-000 or MD-CS101-000		

Table 1.2.3: P1- 19-Pin M23 Pin Assignment and Description (Internal Optical Encoder)



NEED A CORDSET?

The following cordset is available to interface to the 19-pin M23 Connector:

Straight Termination
MD-CS100-000

Right Angle Termination
MD-CS-101-000

See Appendix E for details.

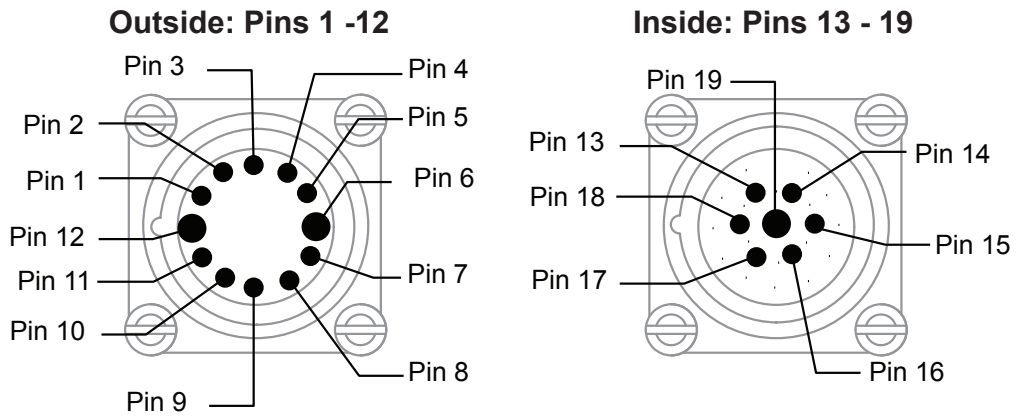

Figure 1.2.2: P1 Connector, Power and I/O



NEED A CORDSET?

The following Euro AC Power Cordset is available:

Straight Termination
MD-CS200-000

Right Angle Termination
MD-CS-201-000

See Appendix E for details.

P3 Connector - AC Power

Pin Assignment - P3 AC Power		
Euro AC Circular (Male)	Function	Description
Pin 1	Chassis Ground	Chassis Ground of the system.
Pin 2	AC Power Line	AC Power Line.
Pin 3	AC Power Neutral	AC Power Neutral.

Table 1.2.4: P3 - AC Power

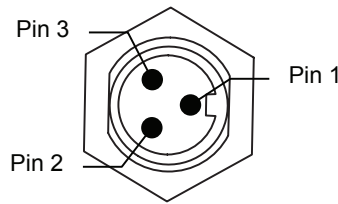

Figure 1.2.3: P3 3-Pin Euro AC Connector



WARNING! Do not plug or unplug AC Power with the power on!



Note: UL Recognition requires the use of the MD-CS20x-000 or Lumberg Equivalent AC Power Cordset.

Options and Accessories

Internal Encoder

Internal differential optical encoders are offered factory-installed with the MDrive34AC Plus Microstepping. Refer to the Encoder Specifications section for available line counts. All encoders come with an index mark.

Control Knob

The MDrive34AC Plus is available with a factory-mounted rear control knob for manual shaft positioning. Not available with Sealed (-65) versions.

Planetary Gearbox

Efficient, low maintenance planetary gearboxes are offered assembled with the MDrive34AC Plus. Refer to gearbox Appendix for details and part numbers.

Parameter Setup Cable and Adapter

The optional 12.0' (3.6m) parameter setup cable part number MD-CC300-000 with adapter MD-ADP-M23 facilitates communications wiring and is recommended with first order. It connects to the MDrive's P1 19-pin male M23 connector.

Cordsets

19-pin M23 single-ended cordsets are offered to speed prototyping of the MDrive34AC Plus. Measuring 13.0' (4.0m) long, they are available in either straight or right angle termination. PVC jacketed cables come with a foil shield and unconnected drain wire.

- Straight Termination MD-CS100-000
- Right Angle Termination..... MD-CS101-000

SECTION 1.3

Introduction to the MDrive42AC Plus Microstepping

The MDrive42AC Plus Microstepping high torque integrated motor and driver is ideal for designers who want the simplicity of a motor with on-board electronics. The integrated electronics of the MDrive42AC Plus eliminate the need to run motor cabling through the machine, reducing the potential for problems due to electrical noise.

The unsurpassed smoothness and performance delivered by the MDrive42AC Plus Microstepping are achieved through IMS's advanced 2nd generation current control. By applying innovative techniques to control current flow through the motor, resonance is significantly dampened over the entire speed range and audible noise is reduced.

The MDrive42AC Plus accepts a broad input voltage range from 95 to 264 VAC, delivering enhanced performance and speed. Oversized input capacitors are used to minimize power line surges, reducing problems that can occur with long runs and multiple drive systems. An extended operating range of -40° to $+85^{\circ}\text{C}$ provides long life, trouble free service in demanding environments.

The MDrive42AC Plus uses a NEMA 42 frame size high torque brushless motor combined with a microstepping driver, and accepts up to 20 resolution settings from full to 256 microsteps per full step, including: degrees, metric and arc minutes. These settings may be changed on-the-fly or downloaded and stored in nonvolatile memory with the use of a simple GUI which is provided. This eliminates the need for external switches or resistors. Parameters are changed via an SPI port.

For use in environments where exposure to dust and liquids may occur, a sealed MDrive42AC Plus Microstepping unit with circular connectors meets IP65 specifications.

The versatile MDrive42AC Plus Microstepping is available in multiple configurations to fit various system needs. Two rotary motor lengths are available as are optional: internal optical encoder; control knob for manual positioning; integrated planetary gearbox. Interface connections are accomplished using standard industrial connectors.

The MDrive42AC Plus is a compact, powerful and inexpensive solution that will reduce system cost, design and assembly time for a large range of brushless motor applications.



Figure 1.3.1: MDrive42AC Plus Microstepping Integrated Motor, Power Supply, and Drive Electronics

Configuring

The IMS Motor Interface software is an easy to install and use GUI for configuring the MDrive42AC Plus from a computer's USB port. GUI access is via the IMS SPI Motor Interface included on the CD shipped with the product, or from www.imshome.com. Optional cables are available for ease of connecting and configuring the MDrive.

The IMS SPI Motor Interface features:

- Easy installation.
- Automatic detection of MDrive version and communication configuration.
- Will not set out-of-range values.
- Tool-tips display valid range setting for each option.
- Simple screen interfaces.

Features and Benefits

- Highly Integrated Microstepping Driver and NEMA 42 High Torque Brushless Motor
- Advanced 2nd Generation Current Control for Exceptional Performance and Smoothness
- Single Supply: 120 or 240 VAC
- Low Cost
- Extremely Compact

- 20 Microstep Resolutions up to
 - 51,200 Steps Per Rev Including:
 - Degrees, Metric, Arc Minutes
- Optically Isolated Logic Inputs will
 - Accept +5 to +24 VDC Signals,
 - Sourcing or Sinking
- Automatic Current Reduction
- Configurable:
 - Motor Run/Hold Current
 - Motor Direction vs. Direction Input
 - Microstep Resolution
 - Clock Type: Step and Direction, Quadrature, Step Up and Step Down
 - Programmable Digital Filtering for Clock and Direction Inputs
- Available Options:
 - Internal Differential Optical Encoder
 - Integrated Planetary Gearbox
 - Control Knob for Manual Positioning
 - IP65 Sealed Configuration
- 3 Rotary Motor Lengths Available
- Current and Microstep Resolution May Be Switched On-The-Fly
- Interface Options:
 - Circular 19-Pin M23
 - Circular 3-Pin Euro AC
- Graphical User Interface (GUI) for Quick and Easy Parameter Setup

SECTION 1.4

MDrive42AC Plus Microstepping Detailed Specifications



WARNING!
Because the MDrive consists of two core components, a drive and a motor, close attention must be paid to the thermal environment where the device is used. See Thermal Specifications.

Electrical Specifications

Input Voltage (+VAC) Range (120 VAC MDrive)	95 to 132 VAC @ 50/60 Hz
Input Current (120 VAC MDrive)	5.6 A Maximum
Input Voltage (+VAC) Range (240 VAC MDrive)	95 to 264 VAC @ 50/60 Hz
Input Current (240 VAC MDrive)	2.8 A Maximum

Thermal Specifications

Heat Sink Temperature (non-condensing humidity)	-40°C to +75°C
Motor Temperature (non-condensing humidity)	-40°C to +90°C

I/O Specifications

Isolated Inputs — Step Clock, Direction and Enable

Resolution	10 Bit
Voltage Range (Sourcing or Sinking)	+5 to +24 VDC
Current (+5 VDC Max)	8.7 mA
Current (+24 VDC Max)	14.6 mA

Communications Specifications

Protocol	SPI
----------	-----

Motion Specifications

Microstep Resolution

Number of Resolutions	20
-----------------------	----

Available Microsteps Per Revolution									
200	400	800	1000	1600	2000	3200	5000	6400	10000
12800	20000	25000	25600	40000	50000	51200	36000 ¹	21600 ²	25400 ³

1=0.01 deg/ μ step 2=1 arc minute/ μ step 3=0.001 mm/ μ step

Digital Filter Range	50 nS to 12.9 μ S (10 MHz to 38.8kHz)
Clock Types	Step/Direction, Quadrature, Clock Up/Clock Down
Step Frequency (Max)	5.0 MHz
Step Frequency Minimum Pulse Width	100 nS

Motor Specifications

Single Length

Holding Torque	1147 oz-in/810 N-cm
Detent Torque	35 oz-in/25 N-cm
Rotor Inertia	0.0917 oz-in-sec ² /6.5 kg-cm ²
Weight (Motor + Driver)	14.07 lb/6.38 kg

Double Length

Holding Torque	2294 oz-in/1620 N-cm
Detent Torque	84 oz-in/59 N-cm
Rotor Inertia	0.1833 oz-in-sec ² /13 kg-cm ²
Weight (Motor + Driver)	21.25 lb/9.64 kg

Setup Parameters

The following table illustrates the setup parameters. These are easily configured using the IMS SPI Motor Interface configuration utility. An optional Parameter Setup Cable is available and recommended with the first order.

MDriveAC Plus Microstepping Setup Parameters				
Name	Function	Range	Units	Default
MHC	Motor Hold Current	0 to 100	percent	5
MRC	Motor Run Current	1 to 100	percent	25
MSEL	Microstep Resolution	1, 2, 4, 5, 8, 10, 16, 25, 32, 50, 64, 100, 108, 125, 127, 128, 180, 200, 250, 256	μsteps per full step	256
DIR	Motor Direction Override	0/1	—	CW
HCDT	Hold Current Delay Time	0 or 2-65535	mSec	500
CLK TYPE	Clock Type	Step/Dir. Quadrature, Up/Down	—	Step/Dir
CLK IOF	Clock and Direction Filter	50 nS to 12.9 μS (10 MHz to 38.8 kHz)	nS (MHz)	200 nS (2.5 MHz)
USER ID	User ID	1-3 characters	Viewable ASCII	IMS
WARN TEMP	Warning Temperature	0 to 125	Degrees Celsius	80
EN ACT	Enable Active State	High/Low	—	High

Table 1.4.1: Setup Parameters

Mechanical Specifications

Dimensions in Inches (mm)

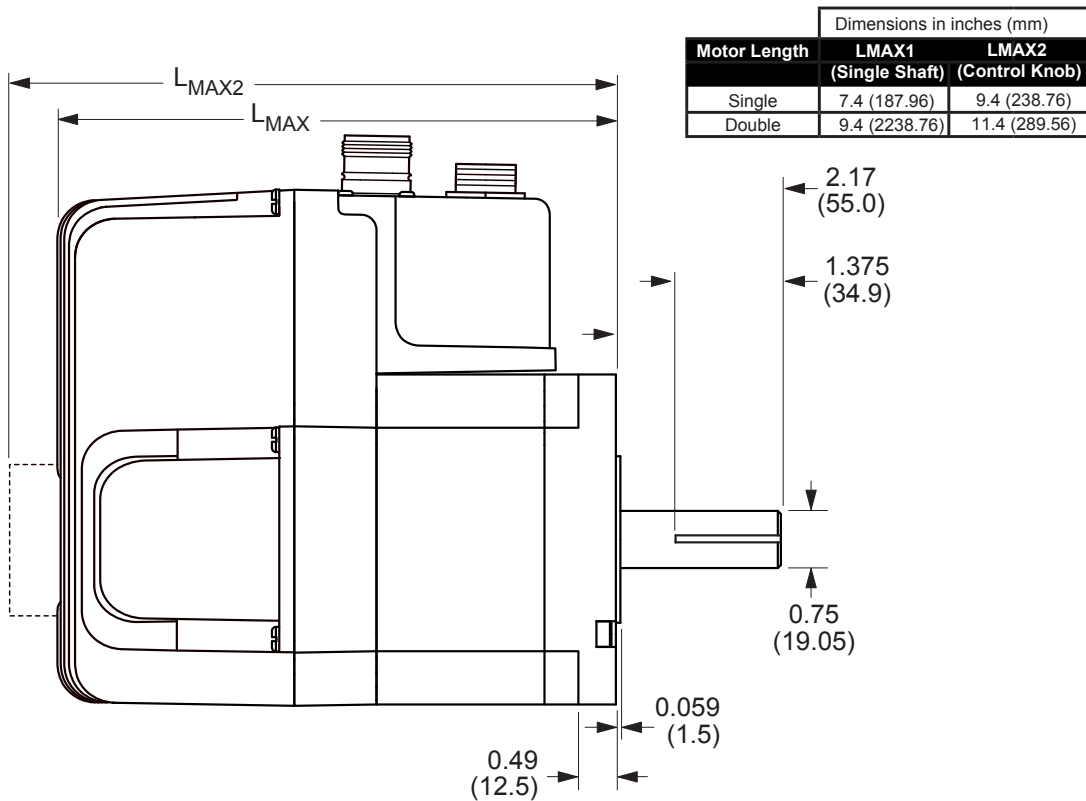
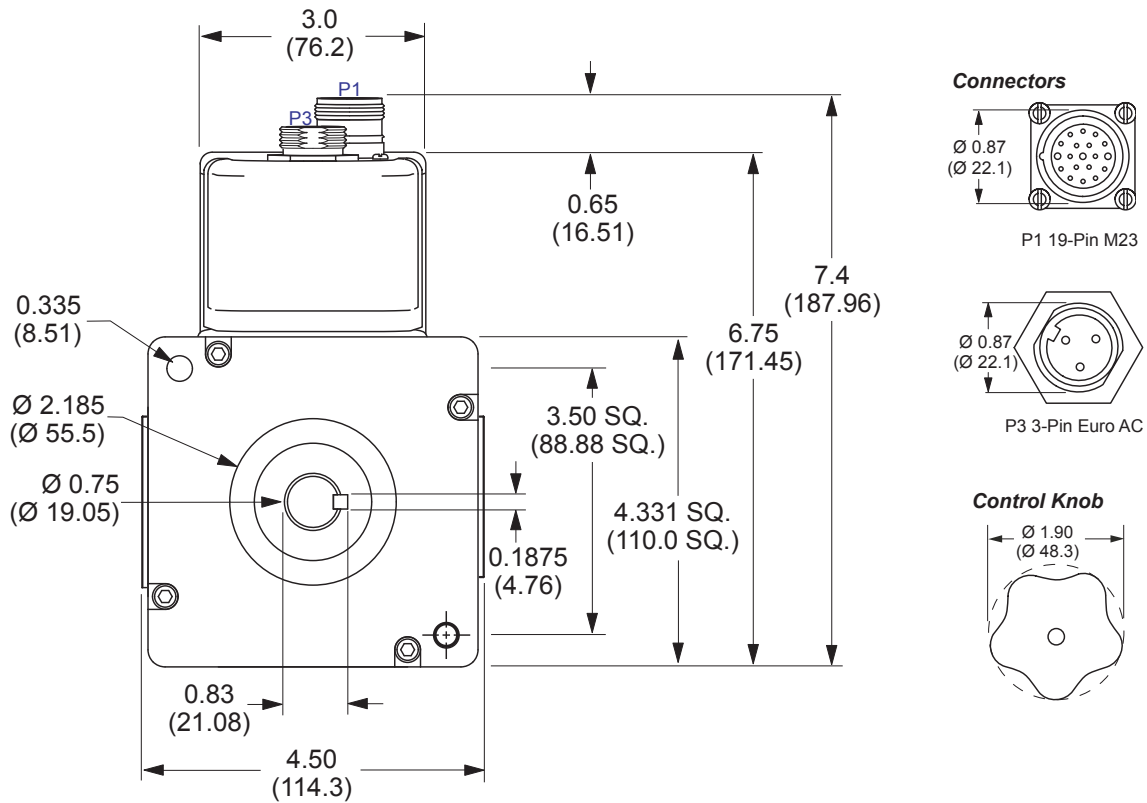

Figure 1.4.1: MDrive42AC Plus Mechanical Specifications

Pin Assignment and Description

P1 19-Pin M23 Connector - I/O and SPI Communications



NEED A CABLE?

The following cordset is available to

interface to the 19-Pin M23 Connector:

Straight Termination

MD-CS100-000

Right Angle Termination

MD-CS-101-000

See Appendix E for details.

Pin Assignment - P1 I/O and SPI Connections		
Pin #	Function	Description
Pin 1	Opto Reference	The signal applied to the Optocoupler Reference will determine the sinking/ or sourcing configuration of the inputs. To set the inputs for sinking operation, a +5 to +24 VDC supply is connected. If sourcing, the Reference is connected to Ground.
Pin 2	Enable	Enable/Disable Input will enable or disable the driver output to the motor. In the disconnected state the driver outputs are enabled in either sinking or sourcing configuration.
Pin 3	N/C	No Connect.
Pin 4	N/C	No Connect.
Pin 5	N/C	No Connect.
Pin 6	N/C	No Connect.
Pin 7	N/C	No Connect.
Pin 8	MOSI	Master-Out/Slave-In. Carries output data from the SPI Master
Pin 9	CS	SPI Chip Select. This signal is used to turn communications on multiple MDM units on or off.
Pin 10	+5 VDC Output	Supply voltage for the MD-CC300-000 Cable ONLY!
Pin 11	GND	Communications Ground.
Pin 12	N/C	No Connect.
Pin 13	Direction/Channel B/ Clock Down	Direction input. The axis direction will be with respect to the state of the Direction Override Parameter. It may also receive quadrature and clock up type inputs if so configured.
Pin 14	N/C	No Connect.
Pin 15	N/C	No Connect.
Pin 16	SPI Clock	The Clock is driven by the SPI Master. The clock cycles once for each data bit.
Pin 17	MISO	Master-In/Slave-Out. Carries output data from the MDM back to the SPI Master.
Pin 18	Step Clock/Channel A/ Clock Up	Step Clock input. The step clock input will receive the clock pulses which will step the motor 1 step for each pulse. It may also receive quadrature and clock up type inputs if so configured.
Pin 19	Fault Output	Open-Drain pending Over-temperature and Over-temperature Fault. When device reaches the temperature specified by the warning temperature the output will pulse at 1 second intervals. When in Over-temperature fault the output will be active continually.
Recommended Cordset		
MD-CS100-000 or MD-CS101-000		

Table 1.4.2: P1- 19-Pin M23 Pin Assignment and Description

P1 19-Pin M23 Connector - I/O, SPI Communications with Encoder Interface Option

Pin Assignment - P1 I/O, SPI and Encoder Connections		
Pin #	Function	Description
Pin 1	Opto Reference	The signal applied to the Optocoupler Reference will determine the sinking/ or sourcing configuration of the inputs. To set the inputs for sinking operation, a +5 to +24 VDC supply is connected. If sourcing, the Reference is connected to Ground.
Pin 2	Enable	Enable/Disable Input will enable or disable the driver output to the motor. In the disconnected state the driver outputs are enabled in either sinking or sourcing configuration.
Pin 3	Index +	Encoder Index + Output.
Pin 4	Channel B +	Encoder Channel B + Output.
Pin 5	Channel B –	Encoder Channel B – Output.
Pin 6	N/C	No Connect.
Pin 7	Channel A +	Encoder Channel A + Output.
Pin 8	MOSI	Master-Out/Slave-In. Carries output data from the SPI Master
Pin 9	CS	SPI Chip Select. This signal is used to turn communications on multiple MDM units on or off.
Pin 10	+5 VDC Output	Supply voltage for the MD-CC300-000 Cable ONLY!
Pin 11	GND	Communications Ground.
Pin 12	N/C	No Connect.
Pin 13	Direction/Channel B/ Clock Down	Direction input. The axis direction will be with respect to the state of the Direction Override Parameter. It may also receive quadrature and clock up type inputs if so configured.
Pin 14	Index –	Encoder Index – Output.
Pin 15	Channel A –	Encoder Channel A – Output.
Pin 16	SPI Clock	The Clock is driven by the SPI Master. The clock cycles once for each data bit.
Pin 17	MISO	Master-In/Slave-Out. Carries output data from the MDM back to the SPI Master.
Pin 18	Step Clock/Channel A/ Clock Up	Step Clock input. The step clock input will receive the clock pulses which will step the motor 1 step for each pulse. It may also receive quadrature and clock up type inputs if so configured.
Pin 19	Fault Output	Open-Drain pending Over-temperature and Over-temperature Fault. When device reaches the temperature specified by the warning temperature the output will pulse at 1 second intervals. When in Over-temperature fault the output will be active continually.
Recommended Cordset		
MD-CS100-000 or MD-CS101-000		

Table 1.4.3: P1- 19-Pin M23 Pin Assignment and Description (Internal Optical Encoder)



NEED A CORDSET?

The following cordset is available to interface to the 19-pin M23 Connector:

Straight Termination
MD-CS100-000

Right Angle Termination
MD-CS-101-000

See Appendix E for details.

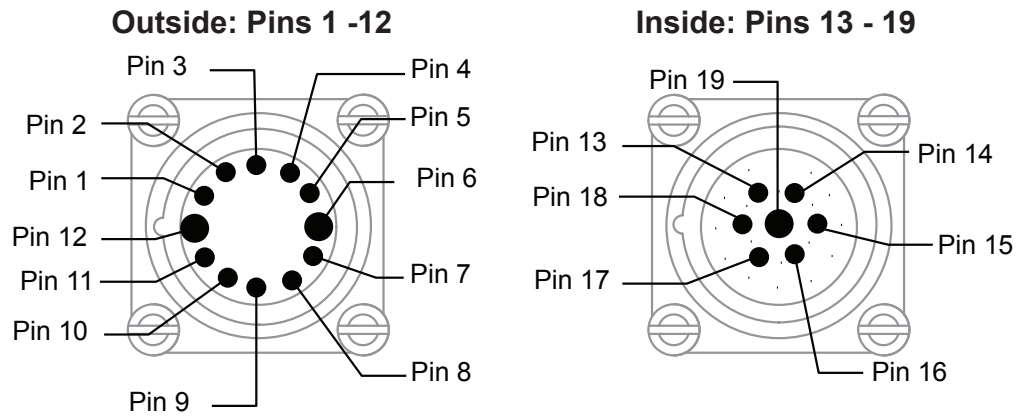

Figure 1.4.2: P1 Connector, Power and I/O



NEED A CORDSET?

The following Euro AC Power Cordset is available:

Straight Termination
MD-CS200-000

Right Angle Termination
MD-CS-201-000

See Appendix E for details.

P3 Connector - AC Power

Pin Assignment - P3 AC Power		
Euro AC Circular (Male)	Function	Description
Pin 1	Chassis Ground	Chassis Ground of the system.
Pin 2	AC Power Line	AC Power Line.
Pin 3	AC Power Neutral	AC Power Neutral.

Table 1.4.4: P3 - AC Power

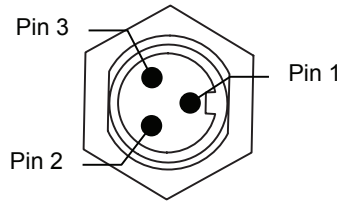

Figure 1.4.3: P3 3-Pin Euro AC Connector



WARNING! Do not plug or unplug AC Power at the Motor with the power on!



Note: UL Recognition requires the use of the MD-CS20x-000 or Lumberg Equivalent AC Power Cordset.

Options and Accessories

Internal Encoder

Internal differential optical encoders are offered factory-installed with the MDrive42AC Plus Microstepping. Refer to the Encoder Specifications section for available line counts. All encoders come with an index mark, unless noted.

Control Knob

The MDrive42AC Plus is available with a factory-mounted rear control knob for manual shaft positioning. Not available with the Sealed (-65) version.

Parameter Setup Cable and Adapter

The optional 12.0' (3.6m) parameter setup cable part number MD-CC300-000 with adapter MD-ADP-M23 facilitates communications wiring and is recommended with first order. It connects to the MDrive's P1 19-pin male M23 connector.

Cordsets

19-pin M23 single-ended cordsets are offered to speed prototyping of the MDrive34AC Plus. Measuring 13.0' (4.0m) long, they are available in either straight or right angle termination. PVC jacketed cables come with a foil shield and unconnected drain wire.

Straight Termination	MD-CS100-000
Right Angle Termination.....	MD-CS101-000



MDRIVE™
MOTOR+DRIVER
AC Plus
MICROSTEPPING

PART 2: INTERFACING AND CONFIGURING

Section 2.1: Logic Interface and Connection

Section 2.2: Connecting SPI Communications

Section 2.3: Using the IMS SPI Motor Interface

Section 2.4: Using User-Defined SPI

Page Intentionally Left Blank

Optically Isolated Logic Inputs

The MDriveAC Plus Microstepping has three optically isolated logic inputs which are located on connector P1. These inputs are isolated to minimize or eliminate electrical noise coupled onto the drive control signals. Each input is internally pulled-up to the level of the optocoupler supply and may be connected to sinking or +5 to +24 VDC sourcing outputs on a controller or PLC. These inputs are:

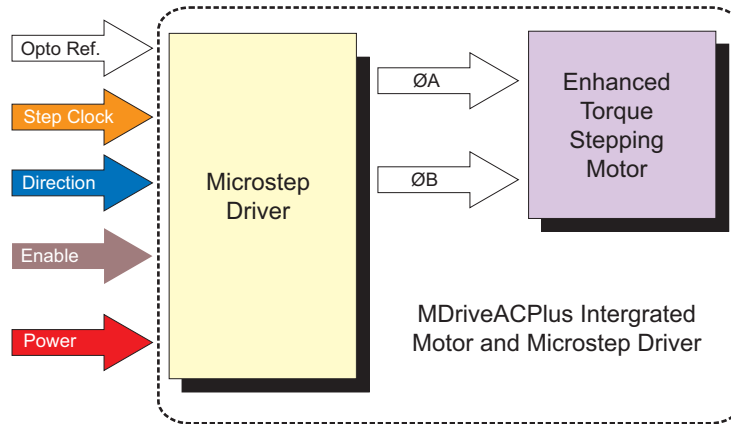

Figure 2.2.1: MDriveAC Plus Microstepping Block Diagram

- 1) Step Clock (SCLK)/Quadrature (CH A)/Clock UP
- 2) Direction (DIR)/Quadrature (CH B)/ Clock DOWN
- 3) Enable (EN)

Of these inputs only step clock and direction are required to operate the MDriveAC Plus Microstepping.

Isolated Logic Input Pins and Connections

The following diagram illustrates the pins and connections for the MDriveAC Plus Microstepping family of products. Careful attention should be paid to verify the connections on the model MDriveAC Plus Microstepping you are using.

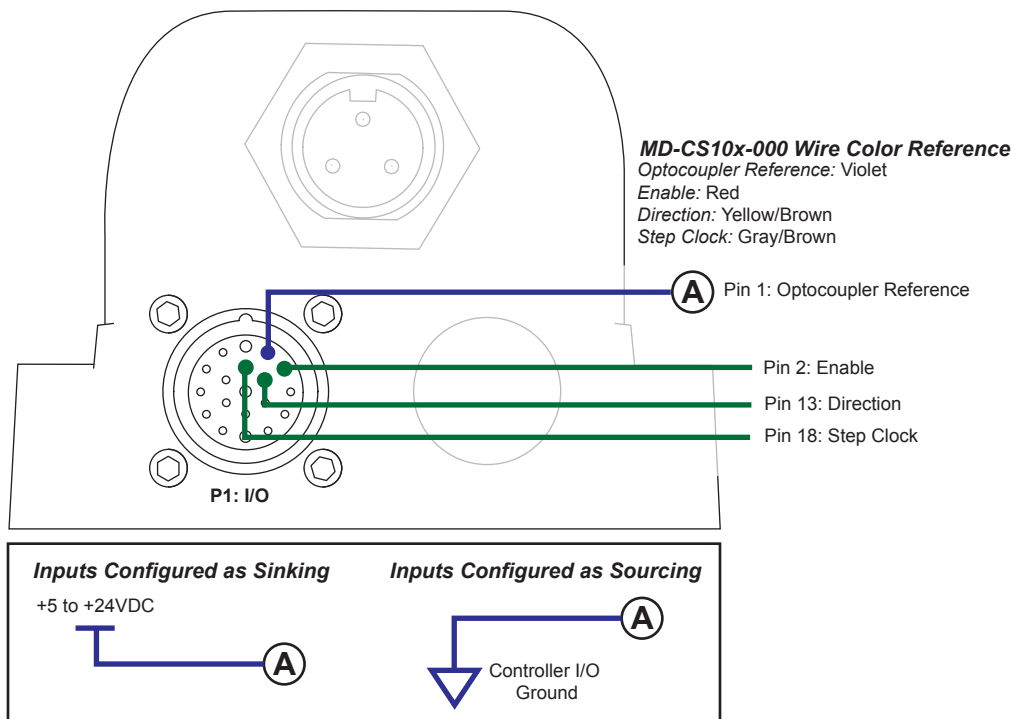

Figure 2.1.1: Isolated Logic Pins and Connections

Isolated Logic Input Characteristics

Enable Input

This input can be used to enable or disable the driver output circuitry. Leaving the enable switch open (Logic HIGH, Disconnected) for sinking or sourcing configuration, the driver outputs will be enabled and the step clock pulses will cause the motor to advance. When this input switch is closed (Logic LOW) in both sinking and sourcing configurations, the driver output circuitry will be disabled. Please note that the internal sine/cosine position generator will continue to increment or decrement as long as step clock pulses are being received by the MDriveAC Plus Microstepping.

Clock Inputs

The MDriveAC Plus Microstepping features the ability to configure the clock inputs based upon how the user will desire to control the drive. By default the unit is configured for the Step/Direction function.

Step Clock

The step clock input is where the motion clock from your control circuitry will be connected. The motor will advance one microstep in the plus or minus direction (based upon the state of the direction input) on the rising edge of each clock pulse. The size of this increment or decrement will depend on the microstep resolution setting.

Direction

The direction input controls the CW/CCW direction of the motor. The input may be configured as sinking or sourcing based upon the state of the Optocoupler Reference. The CW/CCW rotation, based upon the state of the input may be set using the IMS Motor Interface software included with the MDriveAC Plus Microstepping.

Quadrature

The Quadrature clock function would typically be used for following applications where the MDriveAC Plus Microstepping would be slaved to an MDriveAC Plus MicroDrive Motion Control (or other controller) in an electronic gearing application.

Up/Down

The Up/Down clock would typically be used in a dual-clock direction control application.

Input Timing

The direction input and the microstep resolution inputs are internally synchronized to the positive going edge of the step clock input. When a step clock pulse goes HIGH, the state of the direction input and microstep resolution settings are latched. Any changes made to the direction and/or microstep resolution will occur on the rising edge of the step clock pulse following this change. Run and Hold Current changes are updated immediately. The following figure and table list the timing specifications.

Input Filtering

The clock inputs may also be filtered using the Clock IOF pull down of the IMS SPI Motor Interface. The filter range is from 50 nS (10 MHz) to 12.9 μ Sec. (38.8 kHz).

The configuration parameters for the input filtering is covered in detail in Section 2.4: Configuring the MDriveAC Plus Microstepping.

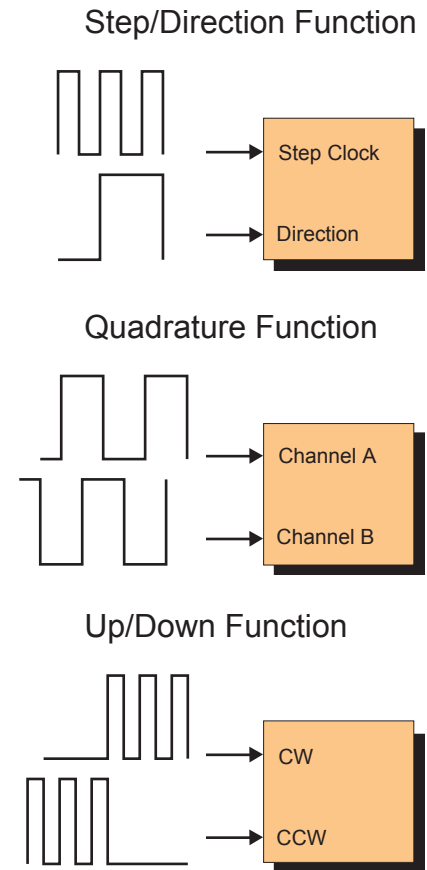

Figure 2.1.2: Input Clock Functions

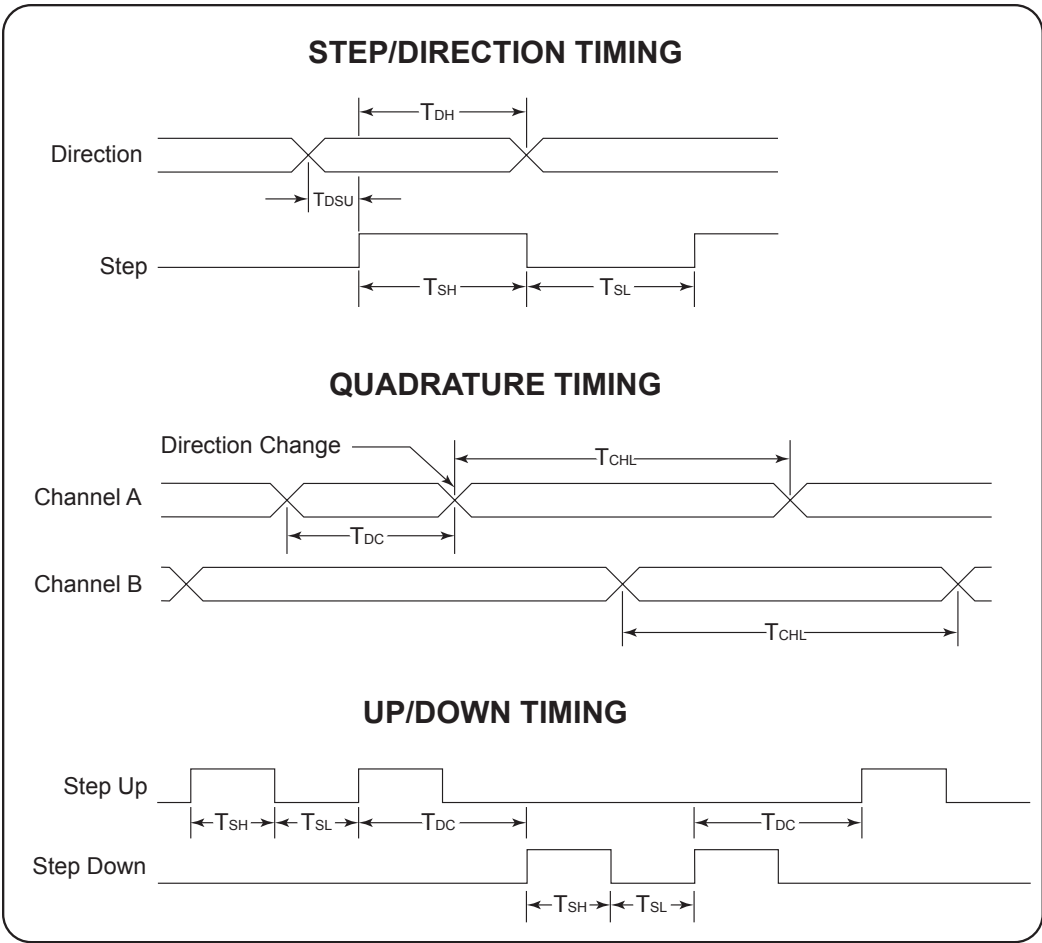

Figure 2.1.3: Clock Input Timing Characteristics

Clock Input Timing					
Symbol	Parameter	Type and Value			
		Step/Direction	Step Up/Down	Quadrature	Units
T_{DSU}	T Direction Set Up	0	—	—	nS min
T_{DH}	T Direction Hold	50	—	—	nS min
T_{SH}	T Step High	250	250	—	nS min
T_{SL}	T Step Low	250	250	—	nS min
T_{DL}	T Direction Change	—	250	250	nS min
T_{CHL}	T Channel High/Low	—	—	400	nS min
F_{SMAX}	F Step Maximum	5	2	—	MHz Max
F_{CHMAX}	F Channel Maximum	—	—	1.25	MHz Max
F_{ER}	F Edge Rate	—	—	5	MHz Max

	Parameter	Turn On	Turn Off	μ S
—	Enable On/Off	25	20	μ S

Table 2.1.1: Input Clocks Timing Table



NOTE: When connecting the Optocoupler Supply, it is recommended that you do not use MDriveAC Plus Power Ground as this will defeat the optical isolation.

Optocoupler Reference

The MDriveAC Plus Microstepping Logic Inputs are optically isolated to prevent electrical noise being coupled into the inputs and causing erratic operation.

There are two ways that the Optocoupler Reference will be connected depending whether the Inputs are to be configured as sinking or sourcing.

Optocoupler Reference	
Input Type	Optocoupler Reference Connection
Sinking	+5 to +24 VDC
Sourcing	Controller Ground

Table 2.1.2: Optocoupler Reference Connection

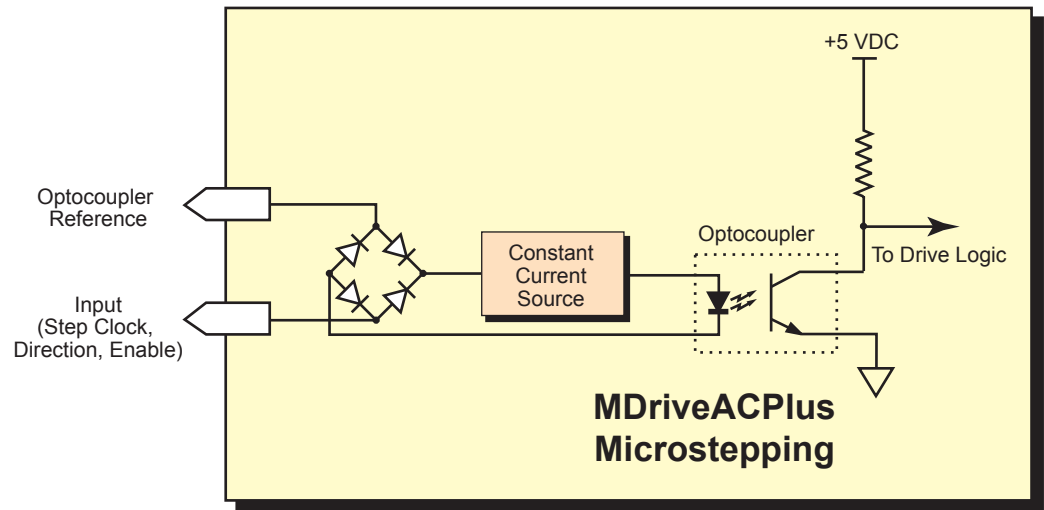

Figure 2.1.4: Optocoupler Input Circuit Diagram

Input Connection Examples

The following diagrams illustrate possible connection/application of the MDriveAC Plus Microstepping Logic Inputs.

Open Collector Interface Example

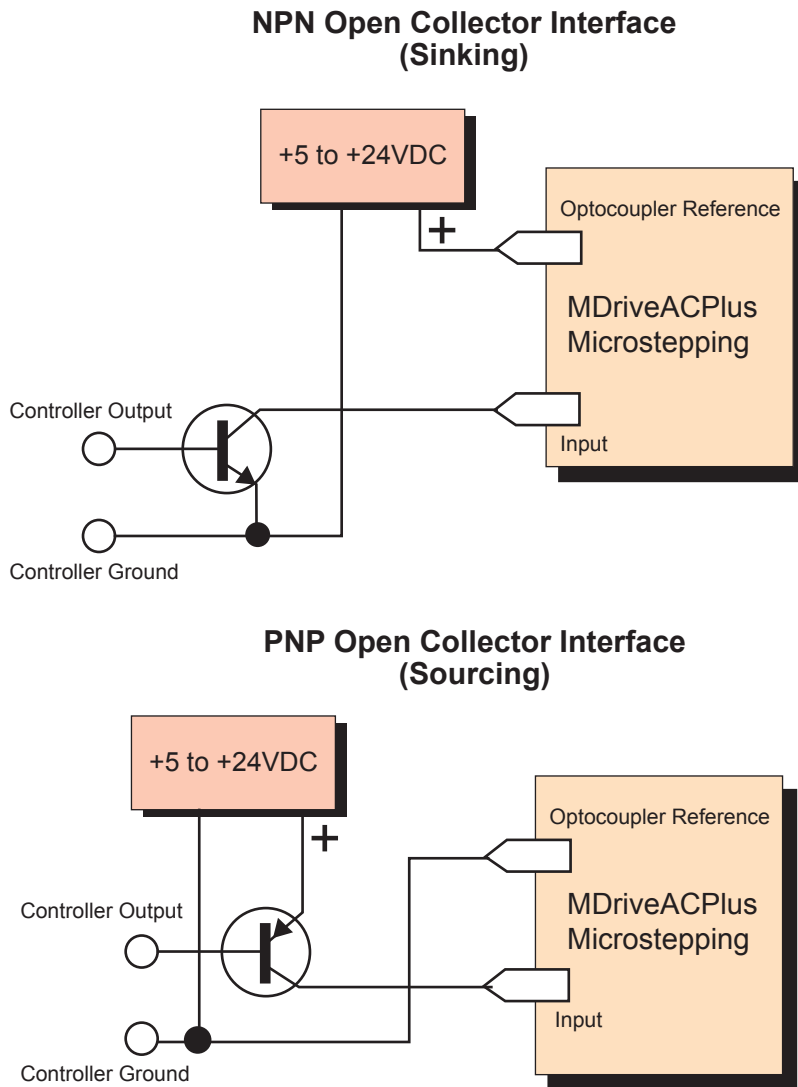
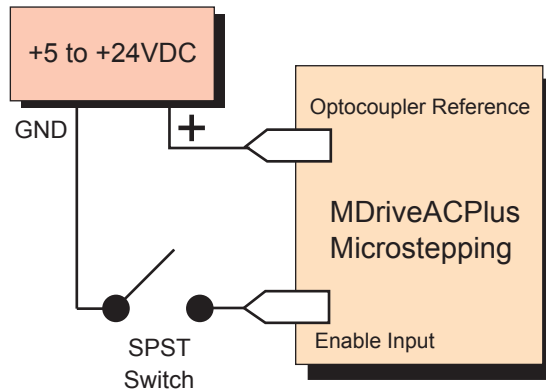

Figure 2.1.5: Open Collector Interface Example

Switch Interface Example

Switch Interface (Sinking)



Switch Interface (Sourcing)

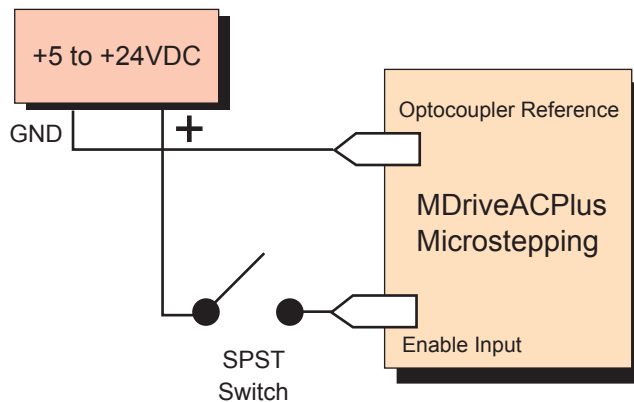

Figure 2.1.6: Switch Interface Example

Fault (Temperature Warning) Output

The MDriveAC Plus Microstepping features an Open-Drain Fault output located at Pin 19 of connector P1. This is an impending over-temperature and over-temperature fault.

When the internal temperature of the MDriveAC Plus reaches the temperature specified by the WARN_TEMP parameter, the output will pulse at 1 second intervals (1/2 second on, 1/2 second off). When an over-temperature fault state is reached the output will latch on.

The output will remain in the latched condition until a power cycle, or new parameter set from the IMS SPI Motor Interface.

Fault Output	
Input Type	Open Drain
Drain-Source Voltage	+5 to +24 VDC
Drain Current	50 mA

Table 2.1.3: Fault Output Specifications

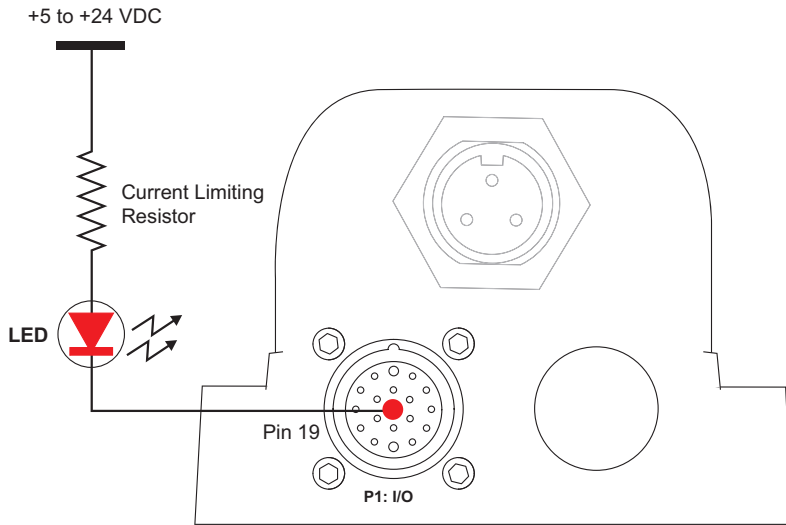

Figure 2.1.7: Fault Output interfaced to an LED

Minimum Required Connections

The connections shown are the minimum required to operate the MDriveAC Plus Microstepping. These are illustrated in both Sinking and Sourcing Configurations. Please reference the Pin Configuration diagram and Specification Tables for the MDriveAC Plus Microstepping connector option you are using.

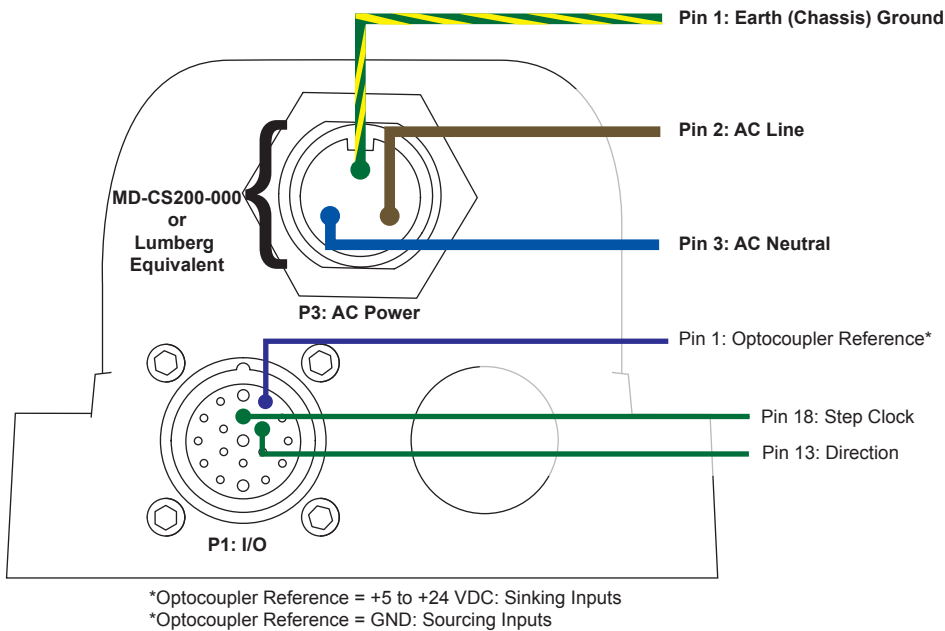

Figure 2.1.8 Minimum Required Connections

Connecting the SPI Interface

The SPI (Serial Peripheral Interface) is the communications and configuration interface.

For prototyping we recommend the purchase of the parameter setup cable MD-CC300-000. Use of this cable requires the adapter MD-ADP-M23.

For more information on prototype development cables, please see Appendix: E: Prototype Development Cables.



Figure 2.2.1: MD-CC300-000 Parameter Setup Cable

SPI Signal Overview

+5 VDC (Output)

This output is a voltage supply for the setup cable only. It is not designed to power any external devices.

SPI Clock

The Clock is driven by the Master and regulates the flow of the data bits. The Master may transmit data at a variety of baud rates. The Clock cycles once for each bit that is transferred.

Logic Ground

This is the ground for all Communications.

MISO (Master In/Slave Out)

Carries output data from the MDriveAC Plus Microstepping units back to the SPI Master. Only one MDriveAC Plus MicroDrive can transmit data during any particular transfer.

CS (SPI Chip Select)

This signal is used to turn communications to multiple MDriveAC Plus Microstepping units on or off.

MOSI (Master Out/Slave In)

Carries output data from the SPI Master to the MDriveAC Plus Microstepping.

SPI Pins and Connections

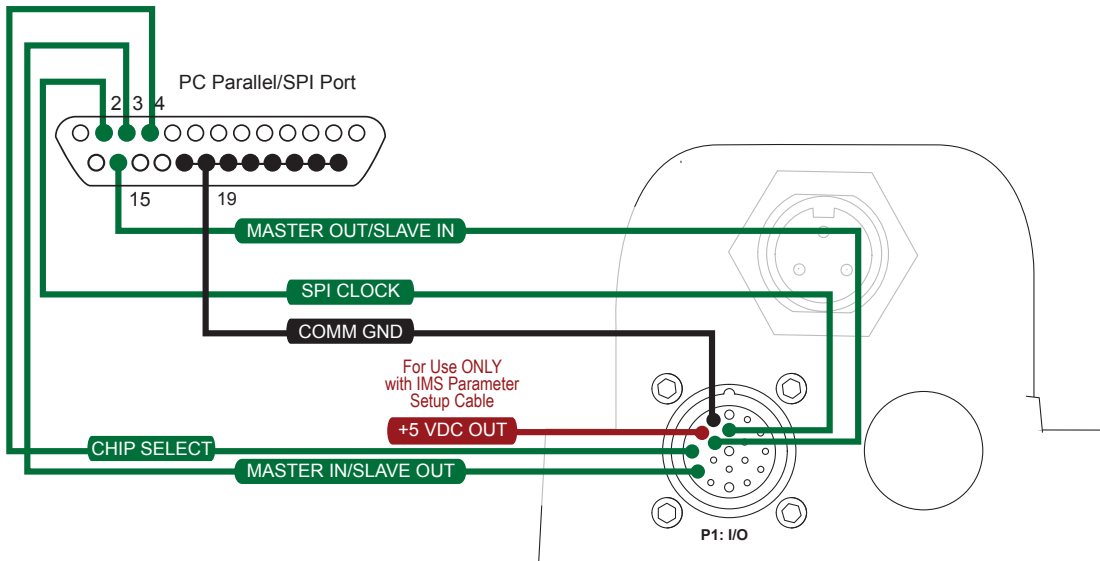

Figure 2.2.2: SPI Pins and Connections, 10-Pin IDC

SPI Master with Multiple MDriveAC Plus Microstepping

It is possible to link multiple MDriveAC Plus Microstepping units in an array from a single SPI Master by wiring the system and programming the user interface to write to multiple chip selects.

Each MDriveAC Plus on the bus will have a dedicated chip select. Only one system MDriveAC Plus can be communicated with/Parameters changed at a time.

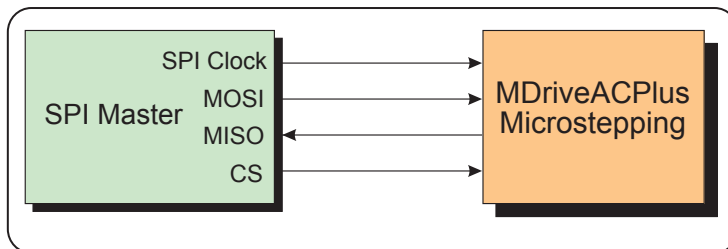

Figure 2.2.4: SPI Master with a Single MDriveAC Plus Microstepping

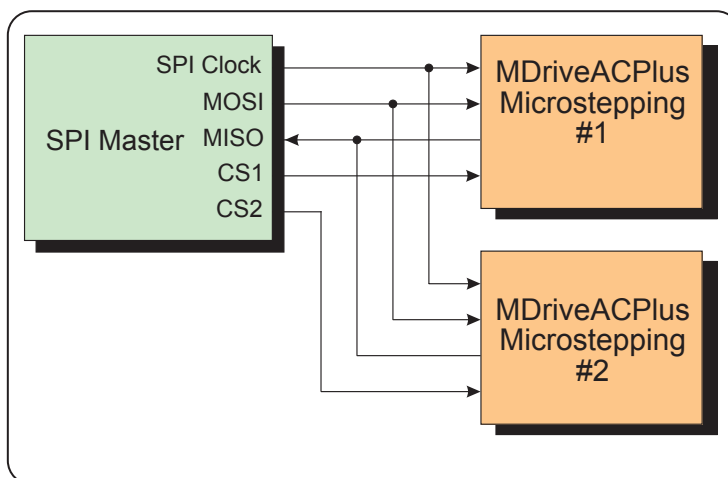

Figure 2.2.5: SPI Master with Multiple MDriveAC Plus Microsteppings

Installation

The IMS SPI Motor Interface is a utility that easily allows you to set up the parameters of your MDriveAC Plus Microstepping. It is available both on the CD that came with your product and on the IMS web site at http://www.imshome.com/software_interfaces.html.

1. Insert the CD into the CD Drive of your PC.
If not available, go to http://www.imshome.com/software_interfaces.html.
2. The CD will auto-start.
3. Click the Software Button in the top-right navigation Area.
4. Click the IMS SPI Interface link appropriate to your operating system.
5. Click SETUP in the Setup dialog box and follow the on-screen instructions.
6. Once IMS SPI Motor Interface is installed, the MDriveAC Plus Microstepping settings can be checked and/or set.

Configuration Parameters and Ranges

MDriveAC Plus Microstepping Setup Parameters				
Name	Function	Range	Units	Default
MHC	Motor Hold Current	0 to 100	percent	5
MRC	Motor Run Current	1 to 100	percent	25
MSEL	Microstep Resolution	1, 2, 4, 5, 8, 10, 16, 25, 32, 50, 64, 100, 108, 125, 127, 128, 180, 200, 250, 256	µsteps per full step	256
DIR	Motor Direction Override	0/1	–	CW
HCDT	Hold Current Delay Time	0 or 2-65535	mSec	500
CLK TYPE	Clock Type	Step/Dir. Quadrature, Up/Down	–	Step/Dir
CLK IOF	Clock and Direction Filter	50 nS to 12.9 µS (10 MHz to 38.8kHz)	nS (MHz)	50nS (10 MHz)
USER ID	User ID	Customizable	1-3 characters	IMS
WARNTMP	Warning Temperature	0 to 125	Degrees Celsius	80

Table 2.3.1: Setup Parameters and Ranges

Color Coded Parameter Values

The SPI Motor Interface displays the parameter values using a predefined system of color codes to identify the status of the parameter.

1. Black: the parameter settings currently stored in the device NVM will display as black.
2. Blue: Blue text indicates a changed parameter setting that has not yet been written to the device.
3. Red: Red text indicates an out-of-range value which cannot be written to the device. When an out-of-range parameter is entered into a field, the "set" button will disable, preventing the value to be written to NVM. To view the valid parameter range, hover the mouse pointer over the field. The valid range will display in a tool tip.

Blue: New Value which has not yet been set to NVM.

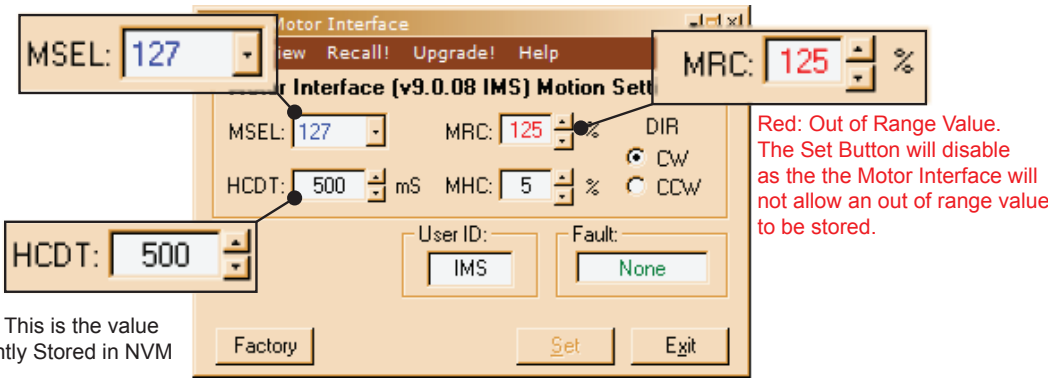

Black: This is the value Currently Stored in NVM

Figure 2.3.1: SPI Motor Interface Color Coding

The color coding is illustrated in Figure 2.3.1.

IMS SPI Motor Interface Menu Options

File

- > Open: Opens a saved *.mot (Motor Settings) file.
- > Save: Saves the current motor settings as a *.mot file for later re-use
- > Save As

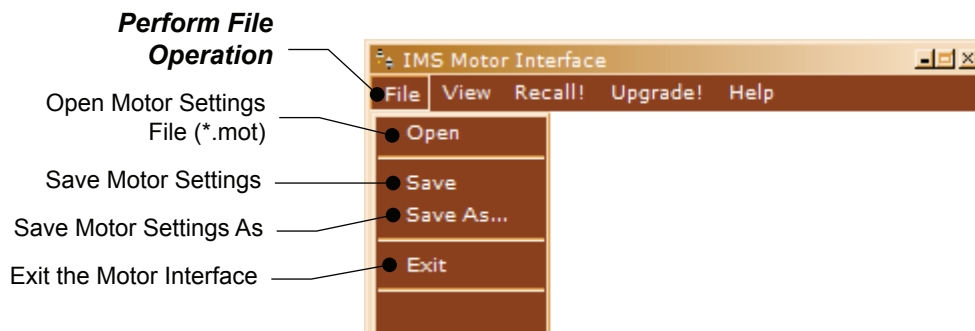

Figure 2.3.2: SPI Motor Interface File Menu

- > Exit - Disconnects from the device and opens the Initialization Dialog.

View

- > Motion Settings: Displays the Motion Settings screen
- > IO Settings: Displays the IO Settings Screen
- > Part and Serial Number: Displays the part and serial number

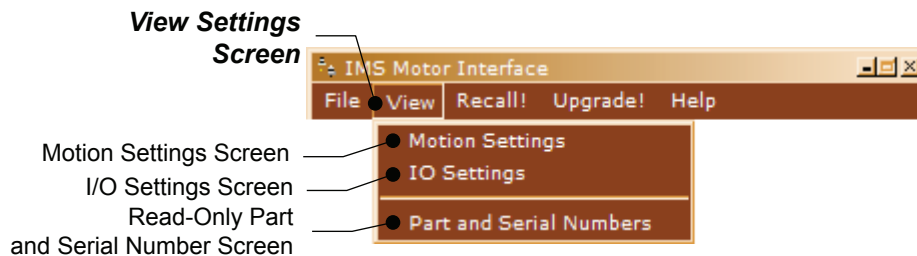

Figure 2.3.3: SPI Motor Interface View Menu

Recall!

Retrieves the settings from the MDriveAC Plus Microstepping.

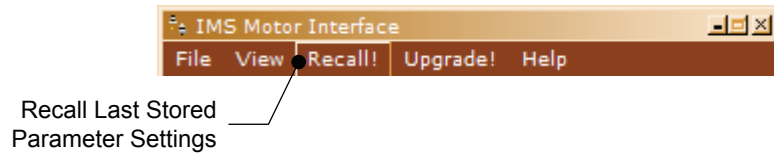

Figure 2.3.4: SPI Motor Interface Recall Menu

Upgrade!

Upgrades the MDriveAC Plus Microstepping firmware by placing the device in Upgrade Mode and launching the firmware upgrader utility.

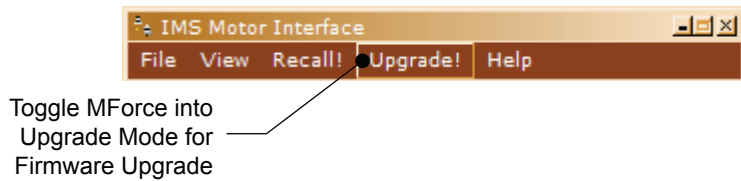

Figure 2.3.5: SPI Motor Interface Upgrade Menu

Help

- > IMS Internet Tutorials: Link to an IMS Web Site page containing Interactive flash tutorials.
- > About: Opens the About IMS and IMS SPI Motor Interface Screen.

Links to the Software Tutorial page of the IMS Website

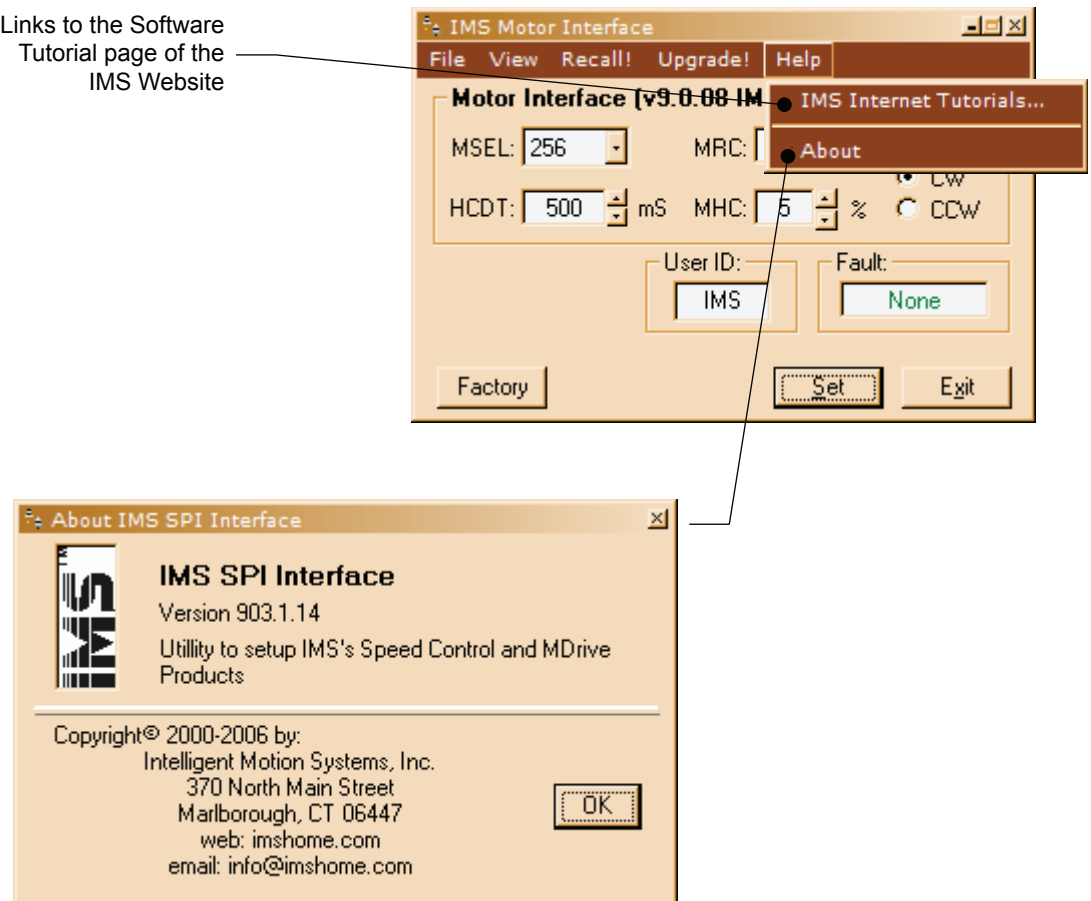

Figure 2.3.6: SPI Motor Interface Help Menu and About Screen

Screen 1: The Motion Settings Configuration Screen

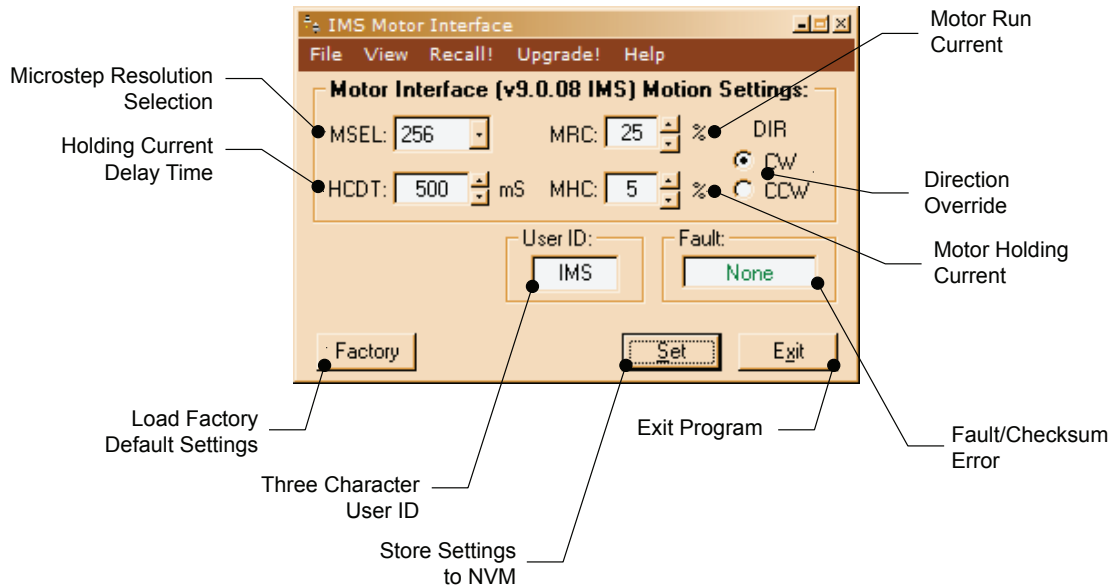

Figure 2.3.7: SPI Motor Interface Motion Settings Screen

The IMS SPI Motor Interface Software opens by default to the Motion Settings Screen shown on the left.

There are six basic parameters that may be set here:

1. MSEL: Microstep Resolution Select.
2. HCDT: Holding Current Delay Time.
3. MRC: Motor Run Current
4. Motor Holding Current
5. User ID: 3-character ID
6. Direction Override: Allows the user to set the CW/CCW direction of the motor in relation to the Direction Input from the SPI Motor Interface.

MSEL (Microstep Resolution Selection)

The MDriveAC Plus Microstepping features 20 microstep resolutions. This setting specifies the number of microsteps per step the motor will move.

The MDriveAC Plus MicroDrive uses a 200 step (1.8°) stepping motor which at the highest (default) resolution of 256 will yield 51,200 steps per revolution of the motor shaft.

See Table 2.3.2 for available Microstep Resolutions.

Microstep Resolution Settings			
Binary μ Step Resolution Settings		Decimal μ Step Resolution Settings	
MS=< μ Steps/Step>	Steps/Revolution	MS=< μ Steps/Step>	Steps/Revolution
1	200	5	1000
2	400	10	2000
4	800	25	5000
8	1600	50	10000
16	3200	100	20000
32	6400	125	25000
64	12800	200	40000
128	25600	250	50000
256	51200		
Additional Resolution Settings			
180	36000 (0.01°/ μ Step)		
108	21600 (1 Arc Minute/ μ Step)		
127	25400 (0.001mm/ μ Step)		

Table 2.3.2: Microstep Resolution Settings



WARNING!
The Maximum
Allowable Setting is
67% Run Current
for 2.0 Amps RMS!

HCDT (Hold Current Delay Time)

The HCDT Motor Hold Current Delay sets time in milliseconds for the Run Current to switch to Hold Current when motion is complete. When motion is complete, the MDriveAC Plus Microstepping will reduce the current in the windings of the motor to the percentage specified by MHC when the specified time elapses.

MRC (Motor Run Current)

The MRC Motor Run Current parameter sets the motor run current to a percentage of the full output current of the MDriveAC Plus driver section.

MHC (Motor Hold Current)

The MHC parameter sets the motor holding current as a percentage of the full output current of the driver. If the hold current is set to 0, the output circuitry of the driver section will disable when the hold current setting becomes active. The hold current setting becomes active HCDT setting mS following the last clock pulse.

DIR (Motor Direction)

The DIR Motor Direction parameter changes the motor direction relative to the direction input signal, adapting the direction of the MDriveAC Plus MicroDrive to operate as your system expects.

User ID

The User ID is a three character (viewable ASCII) identifier which can be assigned by the user. Default is IMS.

IMS SPI Motor Interface Button Functions

The following appear on all of the IMS SPI Motor Interface screens, but will only be documented here.

Factory

Clicking the Factory button will load the MDriveAC Plus Microstepping unit's factory default settings into the IMS SPI Motor Interface.

Connected/Disconnected Indicator

Displays the connected/disconnected state of the software, and if connected, the port connected on.

Set

Set writes the new settings to the MDriveAC Plus. Un-set settings will display as blue text in the setting fields. Once set they will be in black text. Setting the Parameters will also clear most Fault Conditions.

Exit

Disconnects and opens the Initialization dialog.

Screen 2: I/O Settings Configuration Screen

The I/O Settings screen may be accessed by clicking View > IO Settings on the menu bar. This screen is used to configure the Input Clock type, the filtering and the Active High/Low State of the Enable Input.

Input Clock Type

The Input Clock Type translates the specified pulse source that the motor will use as a reference for establishing stepping resolution based on the frequency.

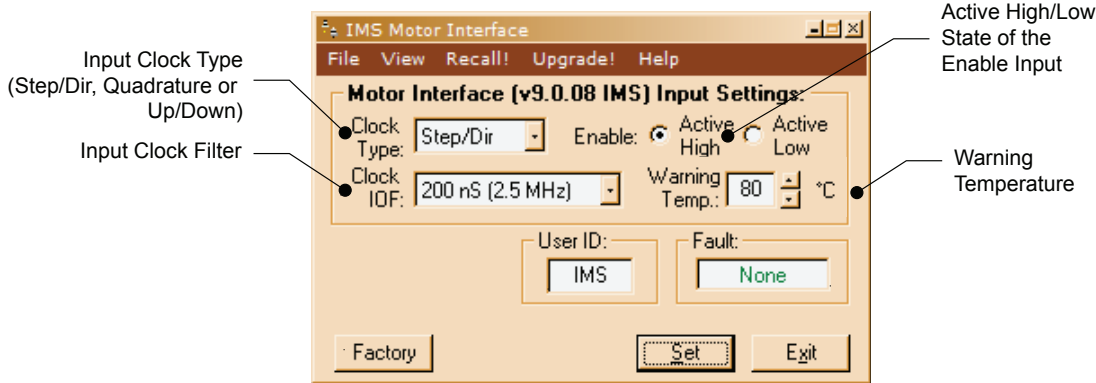

Figure 2.3.8: SPI Motor Interface I/O Settings Screen

The three clock types supported are:

1. Step/Direction
2. Quadrature
3. Up/Down

The Clock types are covered in detail in Section 2.2: Logic Interface and Connection.

Input Clock Filter

The clock inputs may also be filtered using the Clock IOF pull down of the IMS SPI Motor Interface. The filter range is from 50 nS (10 MHz) to 12.9 μ Sec. (38.8 kHz). Table 2.4.3 shows the filter settings.

Input Clock Filter Settings	
Min Pulse	Cutoff Frequency
50 nS	10 MHz
150 nS	3.3 MHz
200 nS	2.5 MHz
300 nS	1.67 MHz
500 nS	1.0 MHz
900 nS	555 kHz
1.7 μ S	294.1 kHz
3.3 μ S	151 kHz
6.5 μ S	76.9 kHz
12.9 μ S	38.8 kHz

Table 2.3.4: Input Clock Filter Settings

Enable Active High/Low

The parameter sets the Enable Input to be Active when High (Default, Disconnected) or Active when Low.

Warning Temperature

The Warning Temperature parameter allows you to set a pending over-temperature threshold for the MDriveAC Plus Microstepping. When that threshold is reached, a "TW" error code will appear in the Fault field. The Fault output will also begin to activate/deactivate at 1 second intervals (1/2 second on, 1/2 second off).

IMS Part Number/Serial Number Screen

The IMS Part Number and Serial Number screen is accessed by clicking "View > Part and Serial Numbers".

This screen is read-only and will display the part and serial number, as well as the fault code if existing. IMS may require this information if calling the factory for support.

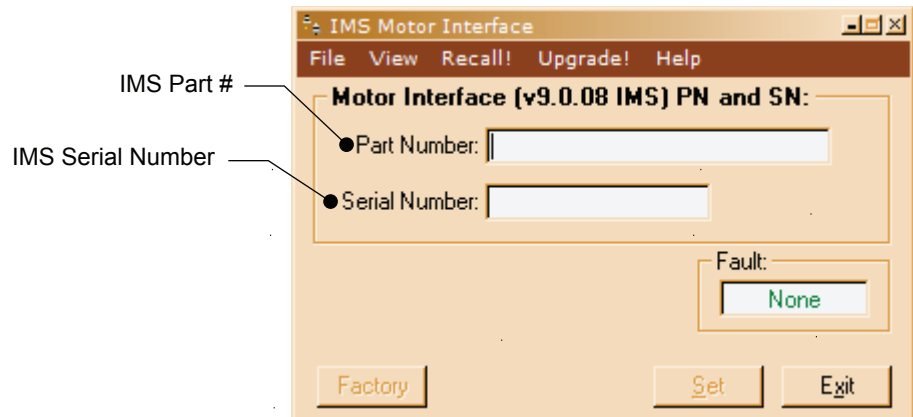

Figure 2.3.9: SPI Motor Interface Part and Serial Number Screen

Fault Indication

All of the IMS SPI Motor Interface Screens have the Fault field visible. This read-only field will display a 2 character error code to indicate the type of fault. The table below shows the error codes.

MDriveAC Plus Microstepping Fault Codes				
Binary Case*	Error Code	Description	Action	To Clear
—	None	No Fault	—	—
4	CS	SPI Checksum Error	Error Displayed	Write to MFM (Set Button)
8	SC/CS	SPI Checksum Error/ Sector Changing	Error Displayed	Write to MFM (Set Button)
16	DFLT	Defaults Checksum Error	Error Displayed	Write to MFM (Set Button)
32	DATA	Settings Checksum Error	Error Displayed	Write to MFM (Set Button)
64	TW	Temperature Warning	Error Displayed	Write to MFM (Set Button)

*All Fault Codes are OR'ed together

Table 2.3.5: MDriveAC Plus Microstepping Fault Codes

Upgrading the Firmware in the MDriveAC Plus Microstepping

The IMS SPI Upgrader Screen

New firmware releases are posted to the IMS web site at <http://www.imshome.com>.

The IMS SPI Motor Interface is required to upgrade your MDriveAC Plus Microstepping product. To launch the Upgrader, click "Upgrade!" on the IMS SPI Motor Interface menu.

The Upgrader screen has 4 read-only text fields that will display the necessary info about your MDriveAC Plus Microstepping.

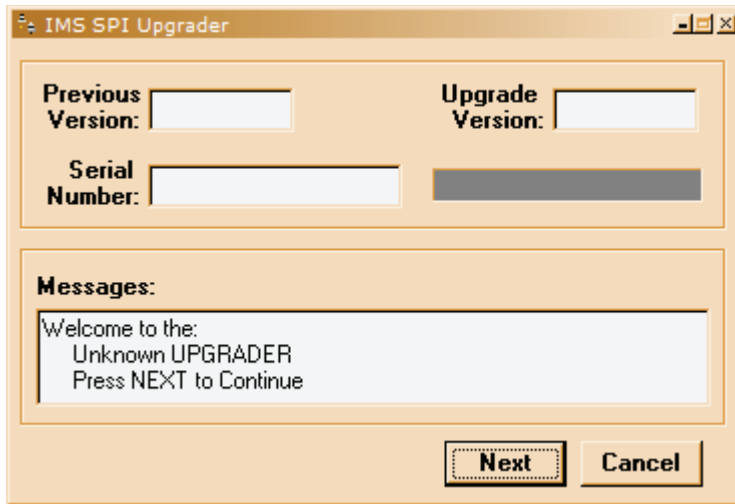

Figure 2.3.10: SPI Motor Interface Upgrade Utility

1. Previous Version: this is the version of the firmware currently on your MDriveAC Plus Microstepping.
2. Serial Number: the serial number of your unit.
3. Upgrade Version: will display the version number of the firmware being installed.
4. Messages: the messages text area will display step by step instructions through the upgrade process.

Upgrade Instructions

Below are listed the upgrade instructions as they will appear in the message box of the IMS SPI Upgrader. Note that some steps are not shown as they are accomplished internally, or are not relevant to the model IMS product you are updating. The only steps shown are those requiring user action.

Welcome Message: Welcome to the Motor Interface UPGRADER! Click NEXT to continue.

Step 2: Select Upgrade File

When this loads, an explorer dialog will open asking you to browse for the firmware upgrade file. This file will have the extension *.ims.

Step 3: Connect SPI Cable

Step 4: Power up or Cycle Power to the MDriveAC Plus

Step 6: Press Upgrade Button

Progress bar will show upgrade progress in blue, Message box will read "Resetting Motor Interface"

Step 8: Press DONE, then select Port/Reconnect.

N NOTE: Once entered into Upgrade Mode, you MUST complete the upgrade. If the upgrade process is incomplete the IMS SPI Motor Interface will continue to open to the Upgrade dialog until the process is completed!

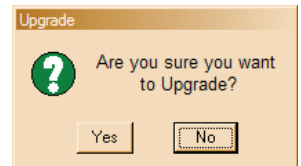

Initialization Screen

This screen will be active under five conditions:

1. When the program initially starts up and seeks for a compatible device.
2. The User selects File > Exit when connected to the device.
3. The User clicks the Exit button while connected to the device.
4. The Upgrade Process completes.
5. The SPI Motor Interface is unable to connect to a compatible device.

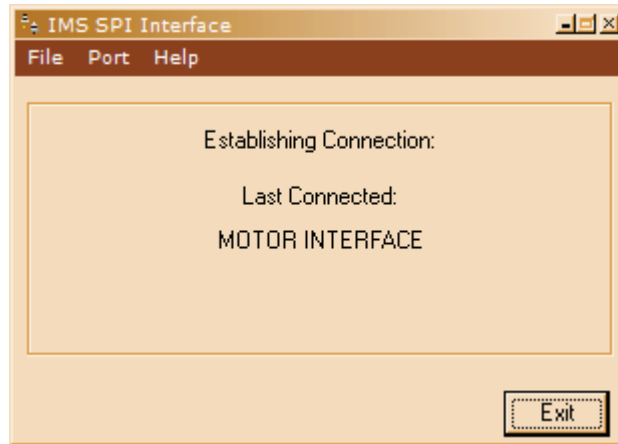

Figure 2.3.11: SPI Motor Interface Initialization

Port Menu

The Port Menu allows the user to select the COM Port that the device is connected to, either a parallel (LPT) Port, or a Hardware Serial or Virtual Serial Port via USB.

The Reconnect option allows the user to reconnect to a unit using the previously used settings.

On open or reconnect, the SPI Motor Interface will also try to auto seek for a connected device.

Communications Port Operations

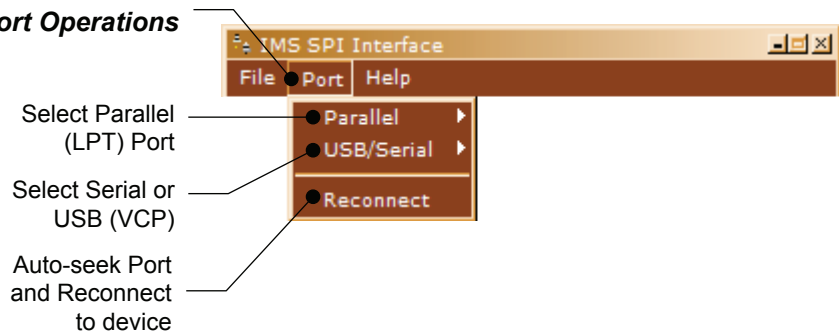

Figure 2.3.12: SPI Motor Interface Port Menu

SECTION 2.4

Using User-Defined SPI

The MDriveAC Plus can be configured and operated through the end-user's SPI interface without using the IMS SPI Motor Interface software and optional parameter setup cable.

An example of when this might be used is in cases where the machine design requires parameter settings to be changed on-the-fly by a software program or multiple system MDriveAC Plus Microstepping units parameter states being written/read.

SPI Timing Notes

1. MSb (Most Significant bit) first and MSB (Most Significant Byte) first.
2. 8 bit bytes.
3. 25 kHz SPI Clock (SCK).
4. Data In (MOSI) on rising clock.
5. Data Out (MISO) on falling clock.

READ ALL

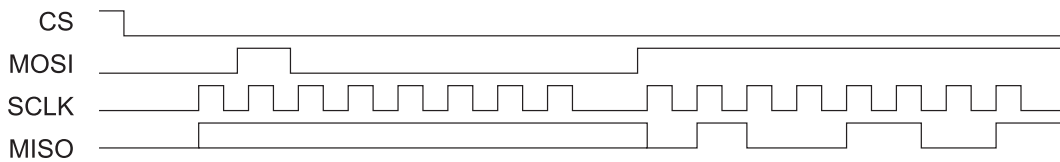

WRITE ALL

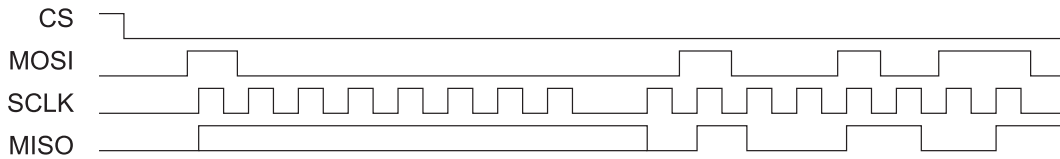

TIMING

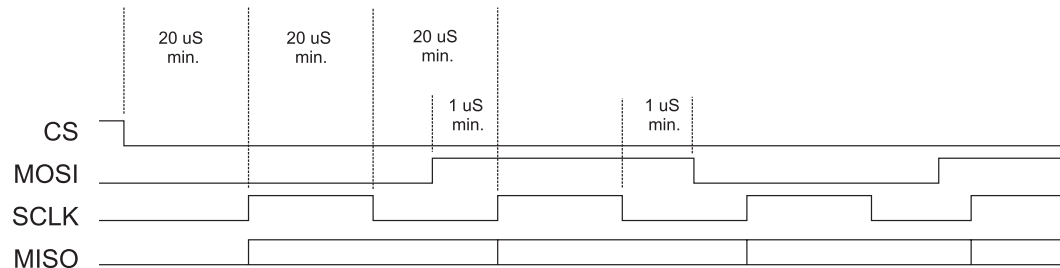

Figure 2.4.1: SPI Timing

Check Sum Calculation for SPI

The values in the example below are 8-bit binary hexadecimal conversions for the following SPI parameters: MRC=25%, MHC=5%, MSEL=256, HCDDT=500 mSec, WARNTEMP=80.

The Check Sum is calculated as follows:

(Hex) 80+19+05+00+00+01+F4+50

Sum = E3 1110 0011

1's complement = 1C 0001 1100 (Invert)

2's complement = 1D 0001 1101 (Add 1)

Send the check sum value of 1D

Note: 80 is always the first command on a write.

Note: Once a write is performed, a read needs to be performed to see if there is a fault. The fault is the last byte of the read.

SPI Commands and Parameters

Use the following table and figure found on the following page together as the Byte order read and written from the MDriveAC Plus Microstepping, as well as the checksum at the end of a WRITE is critical.



SPI Commands and Parameters				
	Command/ Parameter	HEX (Default)	Range	Notes
	READ ALL	0x40	—	Reads the hex value of all parameters
MSB	Device (M)	0x4D	—	M Character precedes every READ
	Version_MSB	0x10	<1-8>.<0-9>	Firmware Version.Sub-version, eg 1.0
	Version_LSB	0x00	<0-99>	Firmware Version Appends to Version_MSB, eg.00
	USR_ID1	0x49	—	Uppercase Letter <I>
	USR_ID2	0x4D	—	Uppercase Letter <M>
	USR_ID3	0x53	—	Uppercase Letter <S>
	MRC	0x19	1-67%	Motor Run Current
	MHC	0x05	0-67%	Motor Hold Current
	MSEL	0x00	0*, 1-259 *0=256	Microstep Resolution (See Table in Section 2.4 for settings)
	DIR_OVRID	0x00	0=no override 1=override dir	Direction Override
	HCDT_HI	0x01	0 or 2-65535	Hold Current Delay Time High Byte
	HCDT_LO	0xF4		Hold Current Delay Time Low Byte
	CLKTYP	0x00	0=s/d, 1=quad, 2=u/d	Input Clock Type
	CLKIOF	0x00	<0-9>	Clock Input Filtering
	WARNTMP	0x50		OVER_TEMP - 5° C
	EN_ACT	0x00	0=High 1=low,	Enable Active High/Low
LSB	FAULT	0x00	—	See Fault Table, Section 2.4
	WRITE ALL	0x80	—	Writes the hex value to the following parameters.
MSB	USR_ID1	0x49	—	Uppercase Letter <I>
	USR_ID2	0x4D	—	Uppercase Letter <M>
	USR_ID3	0x53	—	Uppercase Letter <S>
	MRC	0x19	1-100%	Motor Run Current
	MHC	0x05	0-100%	Motor Hold Current
	MSEL	0x00	0*, 1-259 *0=256	Microstep Resolution (See Table in Section 2.4 for settings)
	DIR_OVRID	0x00	0=no override 1=override dir	Direction Override
	HCDT_HI	0x01	0 or 2-65535	Hold Current Delay Time High Byte
	HCDT_LO	0xF4		Hold Current Delay Time Low Byte
	CLKTYP	0x00	0=s/d, 1=quad, 2=u/d	Input Clock Type
	CLKIOF	0x00	<0-9>	Clock Input Filtering
	WARNTMP	0x50		OVER_TEMP - 5° C
	EN_ACT	0x01	0=Low 1=High	Enable Active High/Low
LSB	CKSUM			34

Table 2.4.1: SPI Commands and Parameters



CHECKSUM CALCULATION

80+49+4D+53+19+05+00+00+01+F4+00+00+50+01=CD
 BINARY = 1100 1101
 1'S COMPLEMENT = 0011 0010
 2'S COMPLEMENT = 0011 0011
 DEC = 51
 HEX = 33

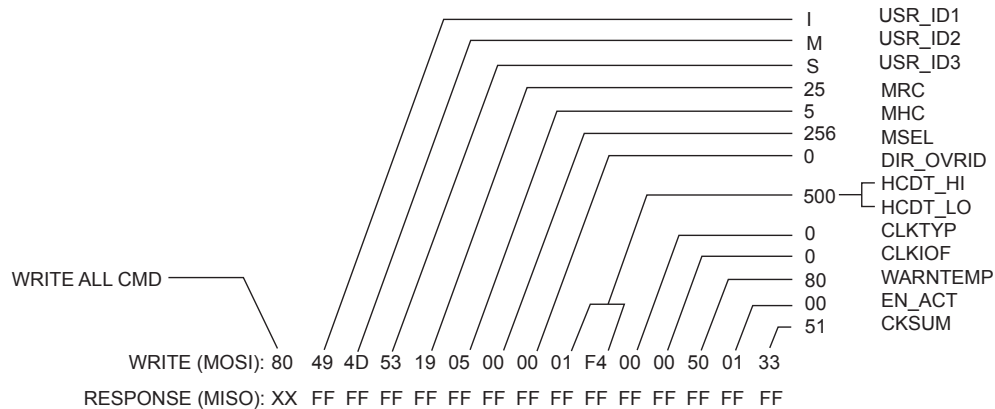
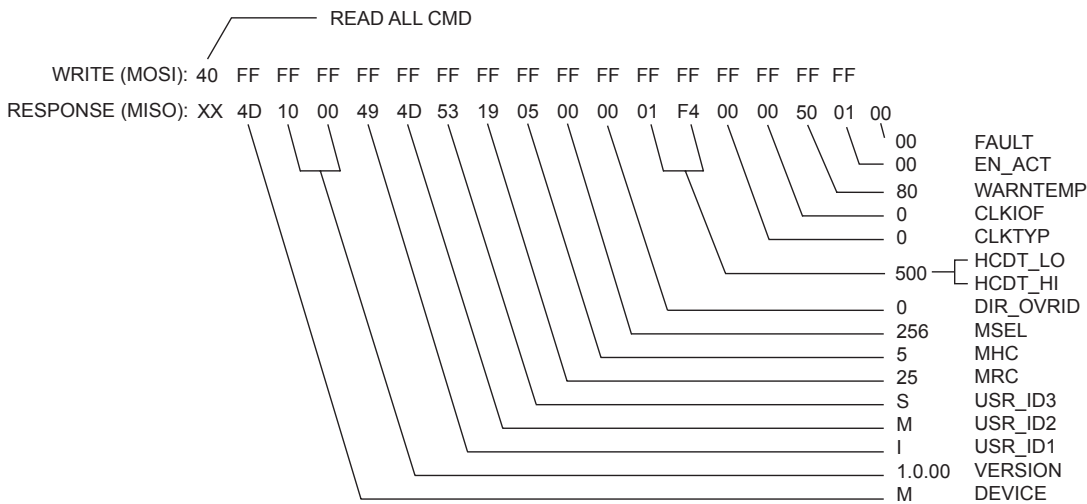
Figure 2.4.2: Read/Write Byte Order for Parameter Settings (Default Parameters Shown)

SPI Communications Sequence

See Timing Diagram and Byte Order figures.

READ

1. Send READ ALL Command 0x40 down MOSI to MDriveAC Plus Microstepping followed by FF (15 Bytes).
2. Receive Parameter settings from MISO MSB First (M-Device) and ending with LSB (Fault).

Write

1. Send WRITE ALL Command (0x80) down MOSI followed by Parameter Bytes beginning with MSB (MRC) and ending with the LSB (Checksum of all parameter Bytes).
2. Response from MISO will be FF (10) Bytes.



MDRIVE™
MOTOR+DRIVER
AC Plus
MICROSTEPPING

APPENDICES

Appendix A: MDriveAC Plus Microstepping Motor Performance

Appendix B: Gear Boxes

Appendix C: Optional Cables and Cordsets

Appendix D: Interfacing an Encoder

APPENDIX A

MDriveAC Plus Microstepping Motor Performance

MDrive34AC Plus Microstepping

Speed-Torque Curves

MDrive34AC - 120VAC

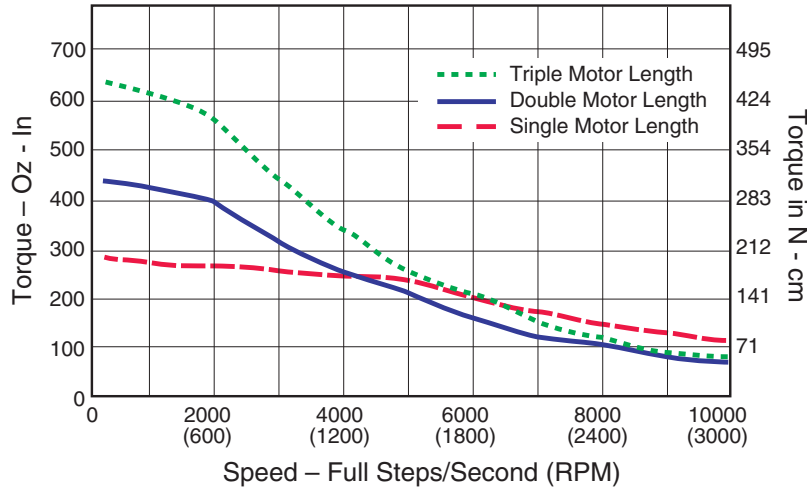

Figure A.1: MDrive34AC Plus 120VAC Microstepping Speed-Torque Curves

MDrive34AC - 240VAC

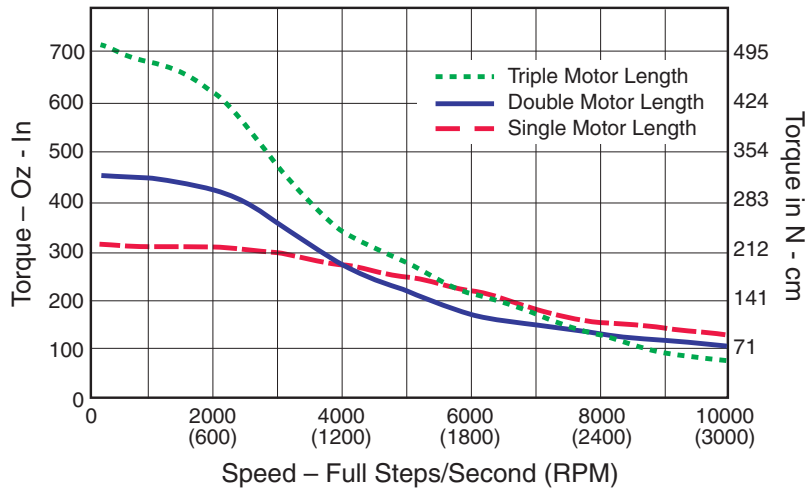

Figure A.2: MDrive34AC Plus 240VAC Microstepping Speed-Torque Curves

Motor Specifications

Single Length

Holding Torque.....	330 oz-in/233 N-cm
Detent Torque.....	10.9 oz-in/7.7 N-cm
Rotor Inertia	0.01416 oz-in-sec ² /1.0 kg-cm ²
Weight (Motor + Driver).....	6.4 lb/2.9 kg

Double Length

Holding Torque.....	500 oz-in/353 N-cm
Detent Torque.....	14.16 oz-in/14.0 N-cm
Rotor Inertia	0.02266 oz-in-sec ² /1.6 kg-cm ²
Weight (Motor + Driver).....	7.7 lb/3.5 kg

Triple Length

Holding Torque.....	750 oz-in/529 N-cm
Detent Torque.....	19.83 oz-in/10.0 N-cm
Rotor Inertia	0.04815 oz-in-sec ² /3.4 kg-cm ²
Weight (Motor + Driver).....	11.0 lb/5.0 kg

MDrive42AC Plus Microstepping

Speed-Torque Curves

MDrive42AC - 120VAC

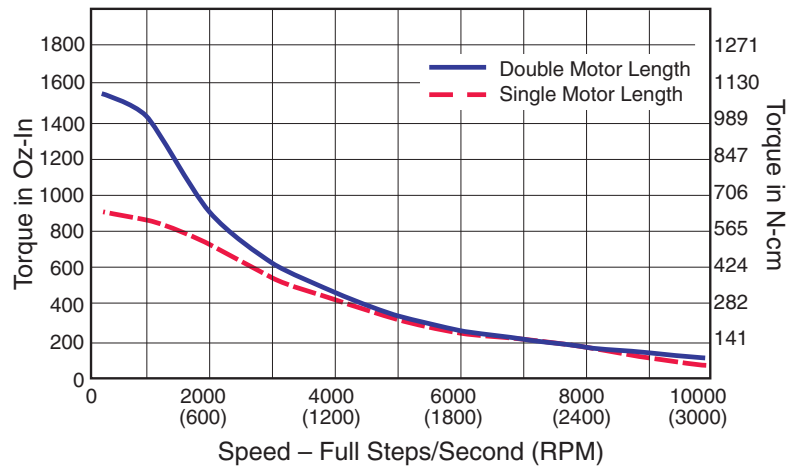

Figure A.3: MDrive42AC Plus 120VAC Microstepping Speed-Torque Curves

MDrive42AC - 240VAC

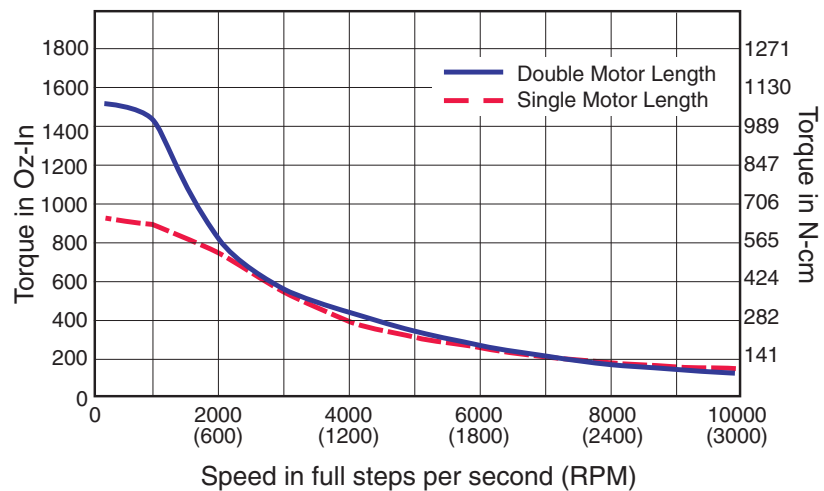

Figure A.4: MDrive42AC Plus 240VAC Microstepping Speed-Torque Curves

Motor Specifications

Single Length

Holding Torque.....	1147 oz-in/810 N-cm
Detent Torque.....	35 oz-in/25 N-cm
Rotor Inertia	0.0917 oz-in-sec ² /6.5 kg-cm ²
Weight (Motor + Driver).....	14.07 lb/6.38 kg

Double Length

Holding Torque.....	2294 oz-in/1620 N-cm
Detent Torque.....	84 oz-in/59 N-cm
Rotor Inertia	0.1833 oz-in-sec ² /13 kg-cm ²
Weight (Motor + Driver).....	21.25 oz/9.64 kg

Section Overview

This section contains guidelines and specifications for MDrives equipped with an optional Planetary Gearbox, and may include product sizes not relevant to this manual.

Shown are:

- Product Overview
- Selecting a Planetary Gearbox
- Mechanical Specifications

Product Overview

All gearboxes are factory installed.

Mode of Function

Optional Planetary Gearbox operate as their name implies: the motor-driven sun wheel is in the center, transmitting its movement to three circumferential planet gears which form one stage. They are arranged on the bearing pins of a planet carrier. The last planet carrier in each sequence is rigidly linked to the output shaft and so ensures the power transmission to the output shaft. The planet gears run in an internally toothed outer ring gear.

Service Life

Depending on ambient and environmental conditions and the operational specification of the driving system, the useful service life of a Planetary Gearbox is up to 10,000 hours. The wide variety of potential applications prohibits generalizing values for the useful service life.

Lubrication

All Planetary Gearbox are grease-packed and therefore maintenance-free throughout their life. The best possible lubricant is used for our MDrive/Planetary Gearbox combinations.

Mounting Position

The grease lubrication and the different sealing modes allow the Planetary Gearbox to be installed in any position.

Operating Temperature

The temperature range for the Planetary Gearbox is between -30 and $+140^{\circ}$ C. However, the temperature range recommended for the Heat Sink of the MDrive is 0 to $+85^{\circ}$ C.

Overload Torque

The permitted overload torque (shock load) is defined as a short-term increase in output torque, e.g. during the start-up of a motor. In these all-metal Planetary Gearbox, the overload torque can be as much as 1.5 times the permitted output torque.

Available Planetary Gearbox

The following lists available Planetary Gearbox, diameter and corresponding MDrive.

Gearbox Diameter	MDrive
81 mm	MDrive34
105 mm or 120 mm	MDrive42

Selecting a Planetary Gearbox

There are many variables and parameters that must be considered when choosing an appropriate reduction ratio for an MDrive with Planetary Gearbox. This Addendum includes information to assist in determining a suitable combination for your application.

Calculating the Shock Load Output Torque (T_{AB})

Note: The following examples are based on picking “temporary variables” which may be adjusted.

The shock load output torque (T_{AB}) is not the actual torque generated by the MDrive and Planetary Gearbox combination, but is a calculated value that includes an operating factor (C_B) to compensate for any shock loads applied to the Planetary Gearbox due to starting and stopping with no acceleration ramps, payloads and directional changes. The main reason the shock load output torque (T_{AB}) is calculated is to ensure that it does not exceed the maximum specified torque for a Planetary Gearbox.

Note: There are many variables that affect the calculation of the shock load output torque. Motor speed, motor voltage, motor torque and reduction ratio play an important role in determining shock load output torque. Some variables must be approximated to perform the calculations for the first time. If the result does not meet your requirements, change the variables and re-calculate the shock load output torque.

Use the equation compendium below to calculate the shock load output torque.

Factors

i	=	Reduction Ratio - The ratio of the Planetary Gearbox.
n_M	=	Motor Speed - In Revolutions Per Minute (Full Steps/Second).
n_{AB}	=	Output Speed - The speed at the output shaft of the Planetary Gearbox.
T_N	=	Nominal Output Torque - The output torque at the output shaft of the Planetary Gearbox.
T_M	=	Motor Torque - The base MDrive torque. Refer to MDrive Speed Torque Tables.
η	=	Gear Efficiency - A value factored into the calculation to allow for any friction in the gears.
T_{AB}	=	Shock Load Output Torque - A torque value calculated to allow for short term loads greater than the nominal output torque.
C_B	=	Operating Factor - A value that is used to factor the shock load output torque.
s_f	=	Safety Factor - A 0.5 to 0.7 factor used to create a margin for the MDrive torque requirement.

Reduction Ratio

Reduction ratio (i) is used to reduce a relatively high motor speed (n_M) to a lower output speed (n_{AB}).

With: $i = n_M \div n_{AB}$ or: motor speed \div output speed = reduction ratio

Example:

The required speed at the output shaft of the Planetary Gearbox is 90 RPM.

You would divide motor speed (n_M) by output speed (n_{AB}) to calculate the proper gearbox ratio.

The MDrive speed you would like to run is approximately 2000 full steps/second or 600 RPM.

NOTE: In reference to the MDrive speed values, they are given in full steps/second on the Speed/Torque Tables. Most speed specifications for the Planetary Gearbox will be given in RPM (revolutions per minute). To convert full steps/second to RPM, divide by 200 and multiply by 60.

Where: 200 is the full steps per revolution of a 1.8° stepping motor.

2000 full steps/second \div 200 = 10 RPS (revolutions per second) \times 60 Seconds = 600 RPM

For the Reduction Ratio (i), divide the MDrive speed by the required Planetary Gearbox output speed.

600 RPM \div 90 = 6.67:1 Reduction Ratio

Referring to the Available Ratio Table at the end of this section, the reduction ratio (i) of the Planetary Gearbox will be 7:1. The numbers in the left column are the rounded ratios while the numbers in the right column are the actual ratios. The closest actual ratio is 6.75:1 which is the rounded ratio of 7:1. The slight difference can be made up in MDrive speed.



Note: The MDrive23 and the numbers and values used in these examples have been chosen randomly for demonstration purposes. Be certain you obtain the correct data for the MDrive you have purchased.

Nominal Output Torque

Calculate the nominal output torque using the torque values from the MDrive's Speed/Torque Tables.

Nominal output torque (T_N) is the actual torque generated at the Planetary Gearbox output shaft which includes reduction ratio (i), gear efficiency (η) and the safety factor (s_f) for the MDrive. Once the reduction ratio (i) is determined, the nominal output torque (T_N) can be calculated as follows:

$$T_N = T_M \times i \times \eta \div s_f \text{ or:}$$

Motor torque \times reduction ratio \times gear efficiency \div safety factor = nominal output torque.

For gear efficiency (η) refer to the Mechanical Specifications for the 7:1 Planetary Gearbox designed for your MDrive.

For motor torque (T_M) see the appropriate MDrive Speed/Torque Table. Dependent on which MDrive you have, the torque range will vary. The torque will fall between the high voltage line and the low voltage line at the indicated speed for the MDrive. (See the example Speed/Torque Table below.)

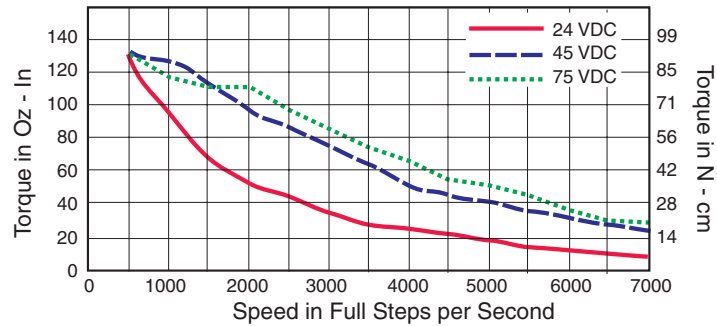

Figure B.1: MDrive23 Torque-Speed Curve

The Speed/Torque Table above is for an MDrive23 Double Length Motor. This MDrive will produce a torque range of 51 to 95 oz-in in the full voltage range at the speed of 2000 Full Steps/Second (600 RPM).

Please note that this is not the usable torque range. The torque output to the Planetary Gearbox must include a safety factor (s_f) to allow for any voltage and current deviations supplied to the MDrive.

The motor torque must include a safety factor (s_f) ranging from 0.5 to 0.7. This must be factored into the nominal output torque calculation. A 0.5 safety factor is aggressive while a 0.7 safety factor is more conservative.

Example:

The available motor torque (T_M) is 51 to 95 oz-in.

NOTE: You may specify a torque less than but not greater than the motor torque range.

For this example the motor torque (T_M) will be 35 oz-in.

A 6.75:1 reduction ratio (i) has been determined.

Gear efficiency (η) = 80% from the appropriate table for the Planetary Gearbox which is used with an MDrive23.

Nominal output torque would be:

Motor torque ($T_M = 35$) \times reduction ratio ($i = 6.75$) \times gear efficiency ($\eta = 0.8$) \div safety factor ($s_f = 0.5$ or 0.7)

$$35 \times 6.75 = 236.25 \times 0.8 = 189 \div 0.5 = 378 \text{ oz-in nominal output torque } (T_N)$$

or

$$35 \times 6.75 = 236.25 \times 0.8 = 189 \div 0.7 = 270 \text{ oz-in nominal output torque } (T_N)$$

With the safety factor (s_f) and gear efficiency (η) included in the calculation, the nominal output torque (T_N) may be greater than the user requirement.

Shock Load Output Torque

The nominal output torque (T_N) is the actual working torque the Planetary Gearbox will generate. The shock load output torque (T_{AB}) is the additional torque that can be generated by starting and stopping with no acceleration ramps, payloads, inertia and directional changes. Although the nominal output torque (T_N) of the Planetary Gearbox is accurately calculated, shock loads can greatly increase the dynamic torque on the Planetary Gearbox.

Each Planetary Gearbox has a maximum specified output torque. In this example a 7:1 single stage MD23 Planetary Gearbox is being used. The maximum specified output torque is 566 oz-in. By calculating the shock load output torque (T_{AB}) you can verify that value is not exceeding the maximum specified output torque.

When calculating the shock load output torque (T_{AB}), the calculated nominal output torque (T_N) and the operating factor (C_B) are taken into account. C_B is merely a factor which addresses the different working conditions of a Planetary Gearbox and is the result of your subjective appraisal. It is therefore only meant as a guide value. The following factors are included in the approximate estimation of the operating factor (C_B):

- Direction of rotation (constant or alternating)
- Load (shocks)
- Daily operating time

Note: The higher the operating factor (C_B), the closer the shock load output torque (T_{AB}) will be to the maximum specified output torque for the Planetary Gearbox. Refer to the table below to calculate the approximate operating factor (C_B).

With the most extreme conditions which would be a C_B of 1.9, the shock load output torque (T_{AB}) is over the maximum specified torque of the Planetary Gearbox with a 0.5 safety factor but under with a 0.7 safety factor.

The nominal output torque (T_N) \times the operating factor (C_B) = shock load or maximum output torque (T_{AB}).

With a 0.5 safety factor, the shock load output torque is greater than the maximum output torque specification of the MDrive23 Planetary Gearbox.

$$(378 \times 1.9 = 718.2 \text{ oz-in.})$$

With a 0.7 safety factor the shock load output torque is within maximum output torque specification of the MDrive23 Planetary Gearbox.

$$(270 \times 1.9 = 513 \text{ oz-in.})$$

The 0.5 safety factor could only be used with a lower operating factor (C_B) such as 1.5 or less, or a lower motor torque.

Note: All published torque specifications are based on $C_B = 1.0$. Therefore, the shock load output torque (T_{AB}) = nominal output torque (T_N).

WARNING! Excessive torque may damage your Planetary Gearbox. If the MDrive/Planetary Gearbox should hit an obstruction, especially at lower speeds (300 RPM or 1000 Full Steps/Second), the torque generated will exceed the maximum torque for the Planetary Gearbox. Precautions must be taken to ensure there are no obstructions in the system.

Determining the Operating Factor (C_B)				
Direction of Rotation	Load (Shocks)	Daily Operating Time		
		3 Hours	8 Hours	24 Hours
Constant	Low*	$C_B=1.0$	$C_B=1.1$	$C_B=1.3$
	Medium**	$C_B=1.2$	$C_B=1.3$	$C_B=1.5$
Alternating	Low†	$C_B=1.3$	$C_B=1.4$	$C_B=1.6$
	Medium††	$C_B=1.6$	$C_B=1.7$	$C_B=1.9$

* Low Shock = Motor turns in one direction and has ramp up at start.

** Medium Shock = Motor turns in one direction and has no ramp up at start.

† Low Shock = Motor turns in both directions and has ramp up at start.

†† Medium Shock = Motor turns in both directions and has no ramp up at start.

Table B.1: Planetary Gearbox Operating Factor

System Inertia

System inertia must be included in the selection of an MDrive and Planetary Gearbox. Inertia is the resistance an object has relative to changes in velocity. Inertia must be calculated and matched to the motor inertia. The Planetary Gearbox ratio plays an important role in matching system inertia to motor inertia. There are many variable factors that affect the inertia. Some of these factors are:

- The type of system being driven.
- Weight and frictional forces of that system.
- The load the system is moving or carrying.

The ratio of the system inertia to motor inertia should be between 1:1 and 10:1. With 1:1 being ideal, a 1:1 to 5:1 ratio is good while a ratio greater than 5:1 and up to 10:1 is the maximum.

Type of System

There are many systems and drives, from simple to complex, which react differently and possess varied amounts of inertia. All of the moving components of a given system will have some inertia factor which must be included in the total inertia calculation. Some of these systems include:

- Lead screw
- Rack and pinion
- Conveyor belt
- Rotary table
- Belt drive
- Chain drive

Not only must the inertia of the system be calculated, but also any load that it may be moving or carrying. The examples below illustrate some of the factors that must be considered when calculating the inertia of a system.

Lead Screw

In a system with a lead screw, the following must be considered:

- The weight and preload of the screw
- The weight of the lead screw nut
- The weight of a table or slide
- The friction caused by the table guideways
- The weight of any parts

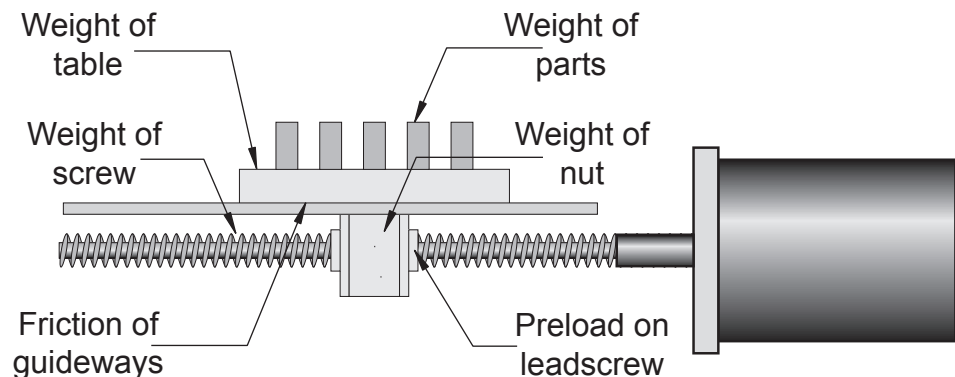

Figure B.2: Lead Screw System Inertia Considerations

Rack and Pinion

In a system with a rack and pinion, the following must be considered:

- The weight or mass of the pinion
- The weight or mass of the rack
- The friction and/or preload between the pinion and the rack
- Any friction in the guidance of the rack
- The weight or mass of the object the rack is moving

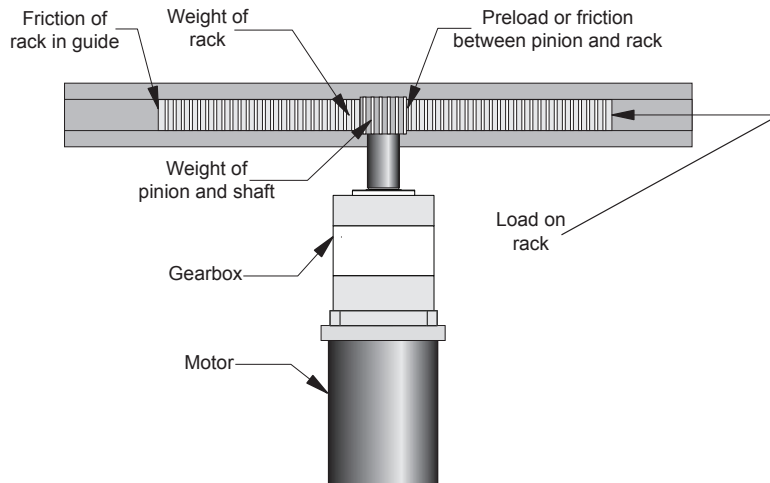

Figure B.3: Rack and Pinion System Inertia Considerations

Conveyor Belt

In a system with a conveyor belt, the following must be considered:

- The weight and size of the cylindrical driving pulley or roller
- The weight of the belt
- The weight or mass and size of the idler roller or pulley on the opposite end
- The angle or elevation of the belt
- Any load the belt may be carrying

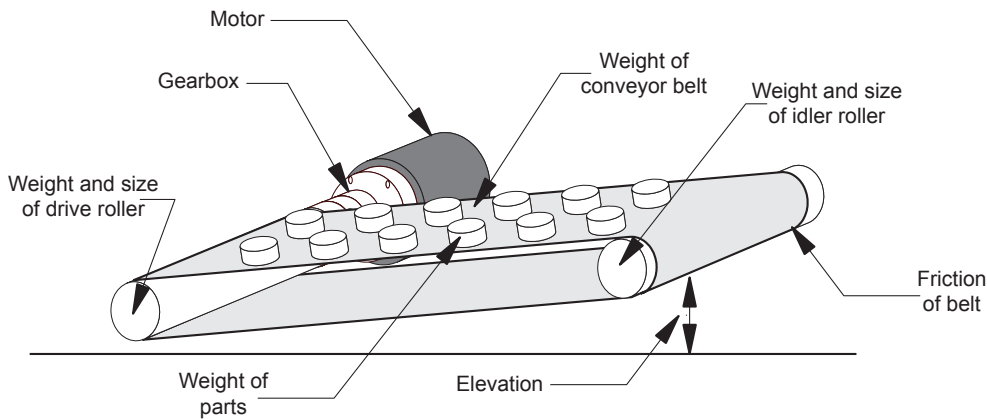

Figure B.4: Conveyor System Inertia Considerations

Rotary Table

In a system with a rotary table, the following must be considered:

- The weight or mass and size of the table
- Any parts or load the table is carrying
- The position of the load on the table, the distance from the center of the table will affect the inertia
- How the table is being driven and supported also affects the inertia

Belt Drive

In a system with a belt drive, the following must be considered:

- The weight or mass and size of the driving pulley
- The tension and/or friction of the belt
- The weight or mass and size of the driven pulley
- Any load the system may be moving or carrying

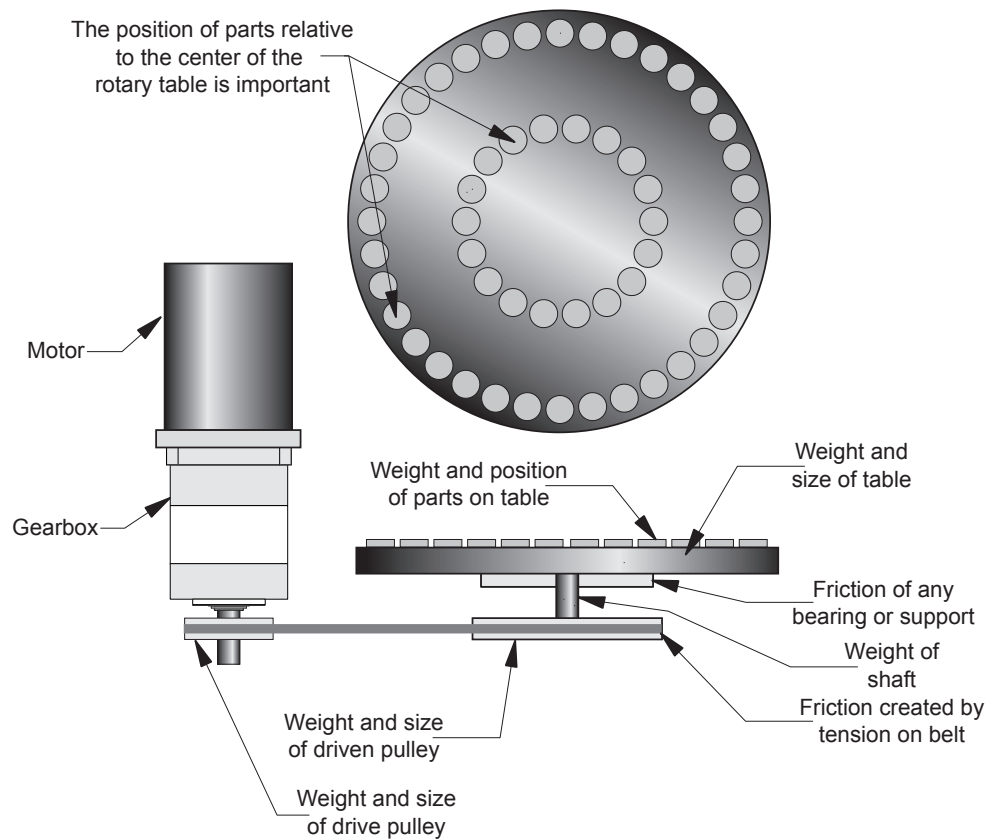

Figure B.5: Rotary Table System Inertia Considerations

Chain Drive

In a system with a chain drive, the following must be considered:

- the weight and size of drive sprocket and any attaching hub
- the weight and size of the driven sprocket and shaft
- the weight of the chain
- the weight of any material or parts being moved

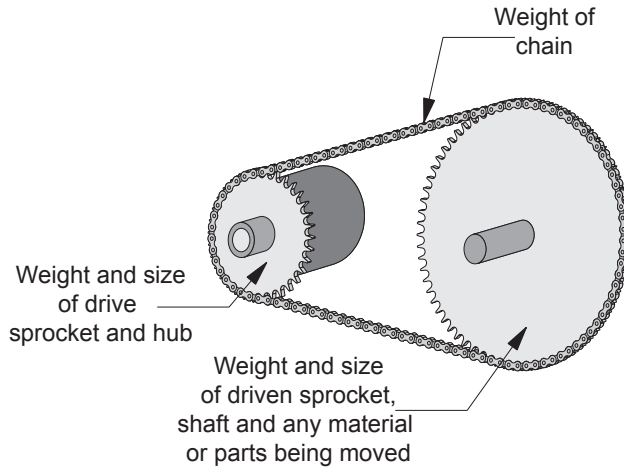

Figure B.6: Chain Drive System Inertia Considerations

Once the system inertia (J_L) has been calculated in oz-in-sec², it can be matched to the motor inertia. To match the system inertia to the motor inertia, divide the system inertia by the square of the gearbox ratio. The result is called Reflected Inertia or (J_{ref}).

$$J_{ref} = J_L \div Z^2$$

Where:

J_L = System Inertia in oz-in-sec²

J_{ref} = Reflected Inertia in oz-in-sec²

Z = Gearbox Ratio

The ideal situation would be to have a 1:1 system inertia to motor inertia ratio. This will yield the best positioning and accuracy. The reflected inertia (J_{ref}) must not exceed 10 times the motor inertia.

Your system may require a reflected inertia ratio as close to 1:1 as possible. To achieve the 1:1 ratio, you must calculate an Optimal Gearbox Ratio (Z_{opt}) which would be the square root of J_L divided by the desired J_{ref} . In this case since you want the system inertia to match the motor inertia with a 1:1 ratio, J_{ref} would be equal to the motor inertia.

$$Z_{opt} = \sqrt{J_L \div J_{ref}}$$

Where:

Z_{opt} = Optimal Gearbox Ratio

J_L = System Inertia in oz-in-sec²

J_{ref} = Desired Reflected Inertia in oz-in-sec² (Motor Inertia)

Planetary Gearbox for MDrive34AC Plus²

MDrive34AC Plus² Planetary Gearbox Parameters

	Permitted Output Torque (oz-in/Nm)	Gearbox Efficiency	Maximum Backlash	Output Side with Ball Bearing			
				Maximum Load (lb-force/N)		Weight (oz/g)	
				Radial	Axial	Gearbox	with Flange
1-STAGE	2832/20.0	0.80	1.0°	90/400	18/80	64.4/1827	66.7/1890
2-STAGE	8496/60.0	0.75	1.5°	135/600	27/120	89.5/2538	92.6/2625
3-STAGE	16992/120.0	0.70	2.0°	225/1000	45/200	92.6/2625	118.5/3360

Table B.2: Planetary Gearbox Specifications – PM81

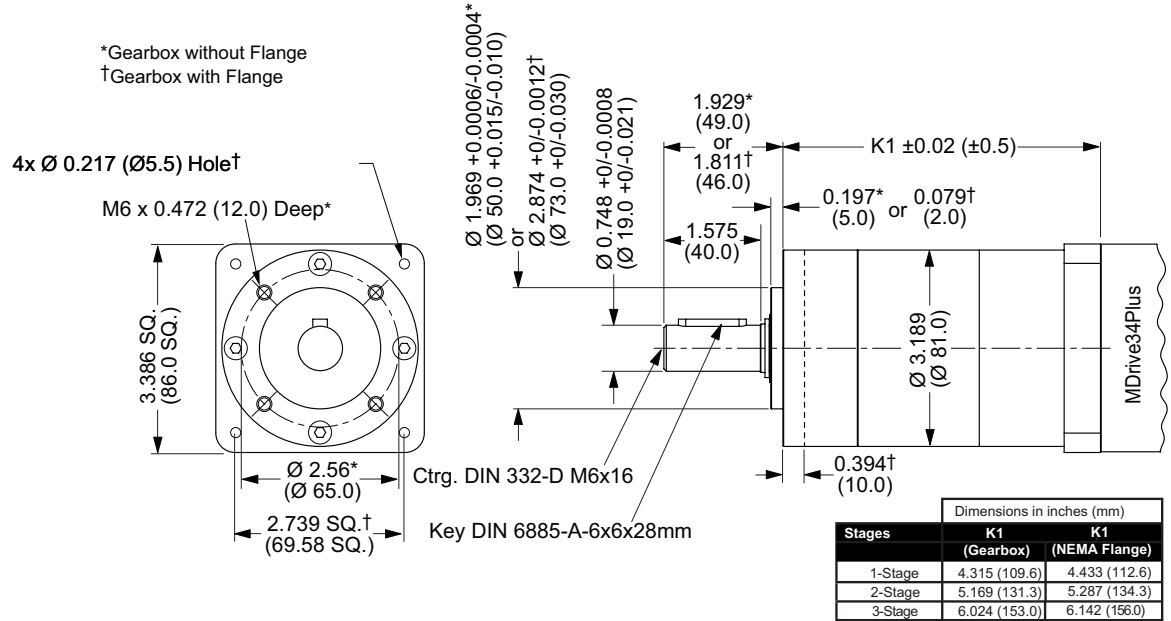

Figure B.7: Planetary Gearbox Specifications for MDrive34AC Plus²

PM81 Gearbox Ratios and Part Numbers

Planetary Gearbox	Ratio (Rounded)	Part Number
1-Stage	3.71:1	G1A1
1-Stage	5.18:1	G1A2
1-Stage	6.75:1	G1A3
2-Stage	13.73:1	G1A4
2-Stage	15.88:1	G1A5
2-Stage	18.37:1	G1A6
2-Stage	19.20:1	G1A7
2-Stage	22.21:1	G1A8
2-Stage	25.01:1	G1A9
2-Stage	26.85:1	G1B1
2-Stage	28.93:1	G1B2
2-Stage	34.98:1	G1B3
2-Stage	45.56:1	G1B4

Planetary Gearbox	Ratio (Rounded)	Part Number
3-Stage	50.89:1	G1B5
3-Stage	58.86:1	G1B6
3-Stage	68.07:1	G1B7
3-Stage	71.16:1	G1B8
3-Stage	78.72:1	G1B9
3-Stage	92.70:1	G1C1
3-Stage	95.18:1	G1C2
3-Stage	99.51:1	G1C3
3-Stage	107.21:1	G1C4
3-Stage	115.08:1	G1C5
3-Stage	123.98:1	G1C6
3-Stage	129.62:1	G1C7
3-Stage	139.14:1	G1C8
3-Stage	149.90:1	G1C9
3-Stage	168.85:1	G1D1
3-Stage	181.25:1	G1D2
3-Stage	195.27:1	G1D3
3-Stage	236.10:1	G1D4
3-Stage	307.55:1	G1D5

Table B.3: Planetary Gearbox Ratios and Part Numbers

Planetary Gearbox for MDrive42AC Plus²

MDrive42AC Plus² Planetary Gearbox Parameters - PM105

	Permitted Output Torque (oz-in/Nm)	Gearbox Efficiency	Maximum Backlash	Output Side with Ball Bearing			
				Maximum Load (lb-force/N)		Weight (lb/kg)	
				Radial	Axial	Gearbox	with Flange
1-STAGE	4956/35.0	0.80	1.0°	135/600	27/120	64.4/1827	9.7/4.4
2-STAGE	14869/105.0	0.75	1.5°	202/900	40/180	89.5/2538	13.2/6.0
3-STAGE	27614/195.0	0.70	2.0°	337/1500	67/300	92.6/2625	16.8/7.6

Table B.4: Planetary Gearbox Specifications – PM105

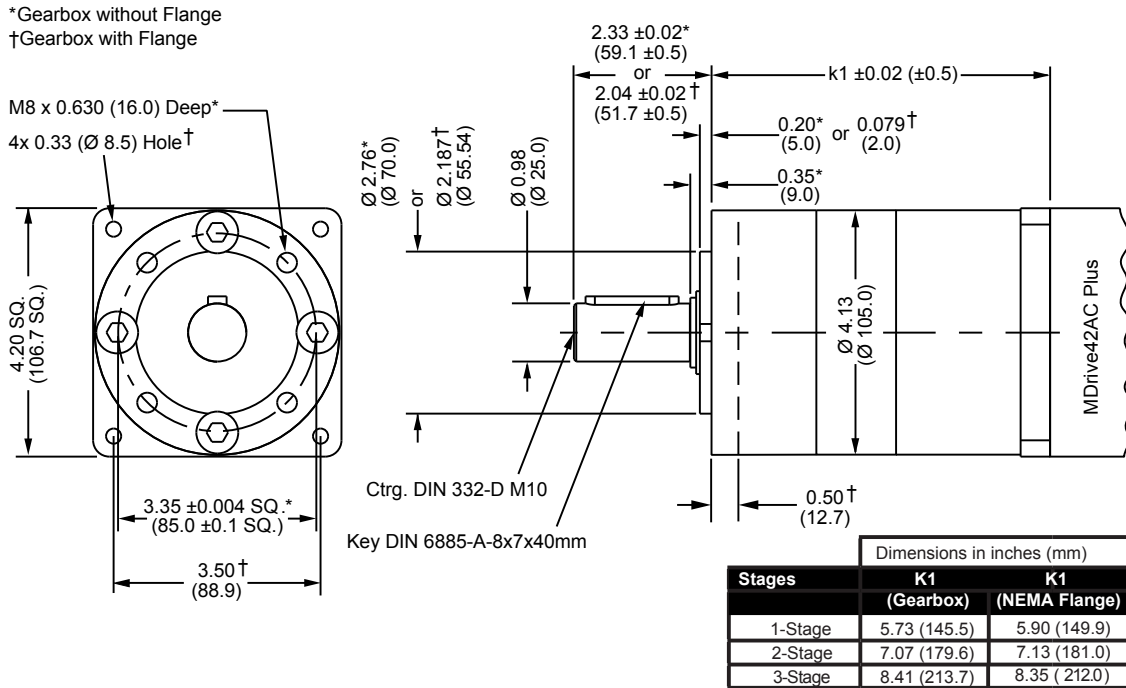

Figure B.8: PM105 Planetary Gearbox Specifications for MDrive42AC Plus²

PM105 Gearbox Ratios and Part Numbers

Planetary Gearbox	Ratio (Rounded)	Part Number
1-Stage	3.71:1	G1A1
1-Stage	5.18:1	G1A2
1-Stage	6.75:1	G1A3
2-Stage	13.73:1	G1A4
2-Stage	15.88:1	G1A5
2-Stage	18.37:1	G1A6
2-Stage	19.20:1	G1A7
2-Stage	22.21:1	G1A8
2-Stage	25.01:1	G1A9
2-Stage	26.85:1	G1B1
2-Stage	28.93:1	G1B2
2-Stage	34.98:1	G1B3
2-Stage	45.56:1	G1B4
3-Stage	50.89:1	G1B5
3-Stage	58.86:1	G1B6
3-Stage	68.07:1	G1B7
3-Stage	71.16:1	G1B8
3-Stage	78.72:1	G1B9
3-Stage	92.70:1	G1C1
3-Stage	95.18:1	G1C2
3-Stage	99.51:1	G1C3
3-Stage	107.21:1	G1C4
3-Stage	115.08:1	G1C5
3-Stage	123.98:1	G1C6
3-Stage	129.62:1	G1C7
3-Stage	139.14:1	G1C8
3-Stage	149.90:1	G1C9
3-Stage	168.85:1	G1D1
3-Stage	181.25:1	G1D2
3-Stage	195.27:1	G1D3
3-Stage	236.10:1	G1D4
3-Stage	307.55:1	G1D5

Table B.5: PM105 Planetary Gearbox Ratios, Inertia Moments and Part Numbers

MDrive42AC Plus² Planetary Gearbox Parameters - PM120

	Permitted Output Torque (oz-in/Nm)	Gearbox Efficiency	Maximum Backlash	Output Side with Ball Bearing			
				Maximum Load (lb-force/N)		Weight (lb/kg)	
				Radial	Axial	Gearbox	with Flange
1-STAGE	7080/50.0	0.80	0.55°	135/600	27/120	64.4/1827	12.3/5.6
2-STAGE	21242/150.0	0.75	0.60°	202/900	40/180	89.5/2538	17.6/8.0
3-STAGE	42484/300.0	0.70	0.65°	337/1500	67/300	92.6/2625	22.9/10.4

Table B.6: Planetary Gearbox Specifications – PM120

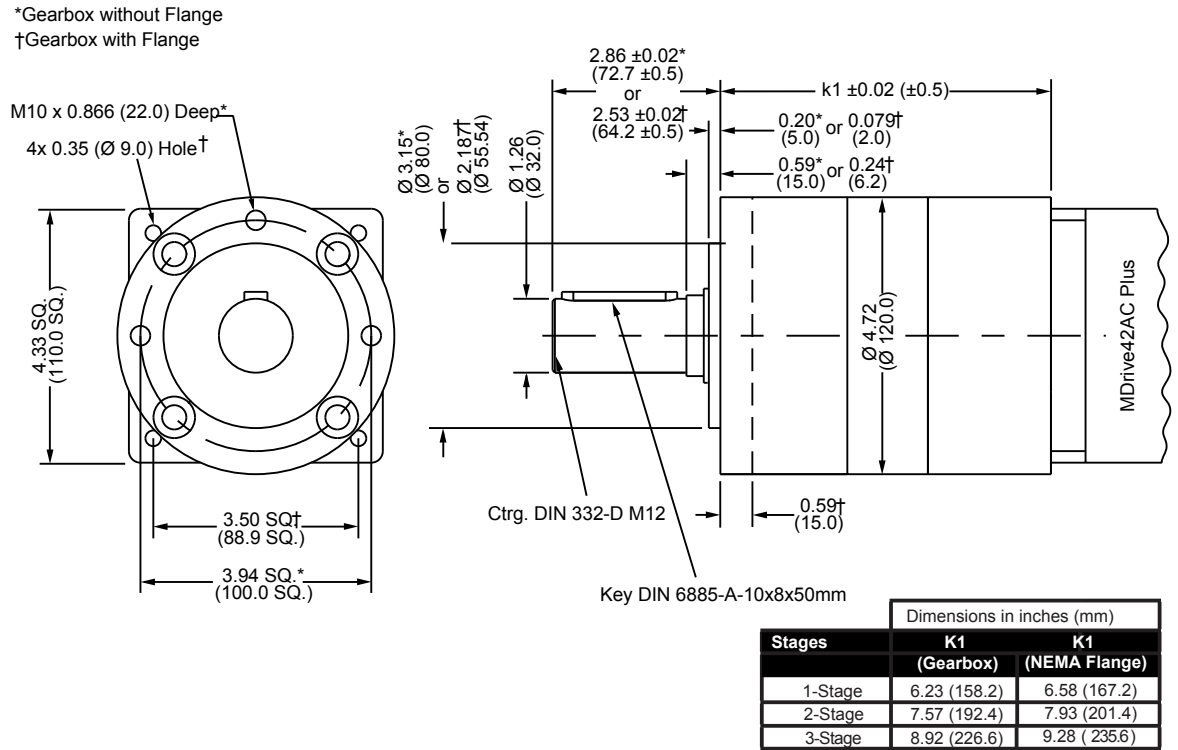

Figure B.9: PM120 Planetary Gearbox Specifications for MDrive42AC Plus²

PM120 Gearbox Ratios and Part Numbers

Planetary Gearbox	Ratio (Rounded)	Part Number
1-Stage	3.71:1	G2A1
1-Stage	6.75:1	G2A3
2-Stage	13.73:1	G2A4
2-Stage	25.01:1	G2A9
2-Stage	45.56:1	G2B4
3-Stage	50.89:1	G2B5
3-Stage	92.70:1	G2C1
3-Stage	168.85:1	G2D1
3-Stage	307.55:1	G2D5

Table B.7: PM120 Planetary Gearbox Ratios, Inertia Moments and Part Numbers

MD-CC300-000: USB to SPI Parameter Setup Cable

The MD-CC300-000 USB to SPI Parameter Setup Cable with adapter MD-ADP-M23 provides a communication connection between the 19-pin M23 connector on the MDriveAC Plus Microstepping and the USB port on a PC.

IMS SPI Interface Software communicates to the Parameter Setup Cable through the PC's USB port.

The Parameter Setup Cable interprets SPI commands and sends these commands to the MDrive through the SPI interface.

Supplied Components: MD-CC300-000 Parameter Setup Cable, USB Cable, USB Drivers, IMS SPI Interface Software.



Figure C.1: MD-CC300-000

WARNING! DO NOT connect or disconnect the MD-CC300-000 Communications Converter Cable from MDrive while power is applied!

N NOTE: All three components, the MD-CC300-000, MD-ADP-M23 and MD-CS10x-000, or their equivalent are required for prototyping.

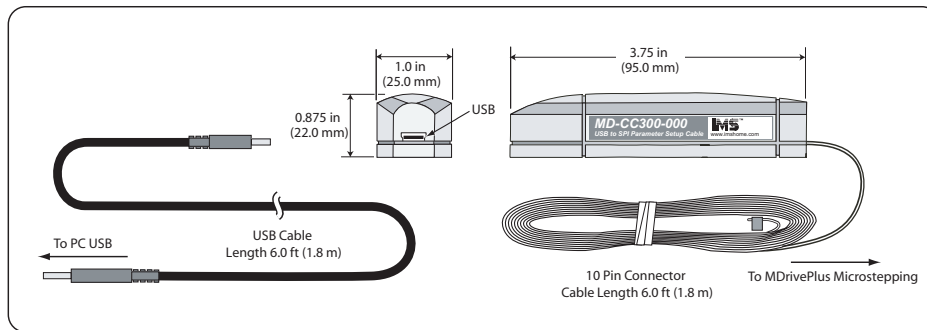

Figure C.2: MD-CC300-000 Mechanical Specifications

Installation Procedure for the MX-CC300-000

These Installation procedures are written for Microsoft Windows XP Service Pack 2. Users with earlier versions of Windows please see the alternate installation instructions at the IMS web site (<http://www.imshome.com>).

The installation of the MD-CC300-000 requires the installation of two sets of drivers:

- Drivers for the IMS USB to SPI Converter Hardware.
- Drivers for the Virtual Communications Port (VCP) used to communicate to your IMS Product.

Therefore the Hardware Update wizard will run twice during the installation process.

The full installation procedure will be a two-part process: Installing the Cable/VCP drivers and Determining the Virtual COM Port used.

Installing the Cable/VCP Drivers

- 1) Plug the USB Converter Cable into the USB port of the MD-CC300-000.
- 2) Plug the other end of the USB cable into an open USB port on your PC.
- 3) Your PC will recognize the new hardware and open the Hardware Update dialog.
- 4) Select "No, not this time" on the radio buttons in answer to the query "Can Windows Connect to Windows Update to search for software?" Click "Next" (Figure C.3).



Figure C.3: Hardware Update Wizard

- 5) Select “Install from a list or specific location (Advanced)” on the radio buttons in answer to the query “What do you want the wizard to do?” Click “Next” (Figure C.4).

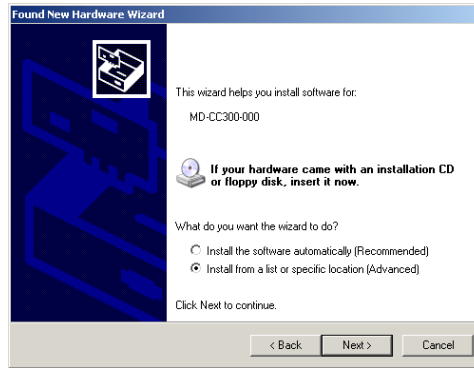

Figure C.4: Hardware Update Wizard Screen 2

- 6) Select “Search for the best driver in these locations.”
(a) Check “Include this location in the search.”
(b) Browse to the MDrive CD [Drive Letter]:\ Cable_Drivers\MD-CC303-000_DRIVERS.
(c) Click Next (Figure C.5).

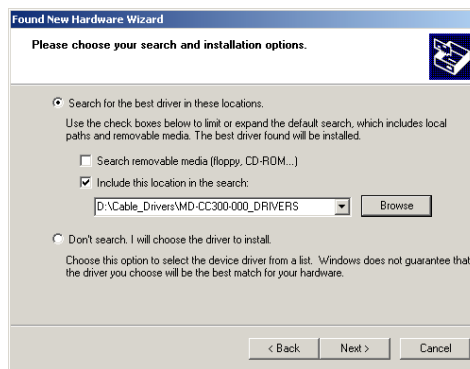

Figure C.5: Hardware Update Wizard Screen 3

- 7) The drivers will begin to copy.
8) On the Dialog for Windows Logo Compatibility Testing, click “Continue Anyway” (Figure C.6).

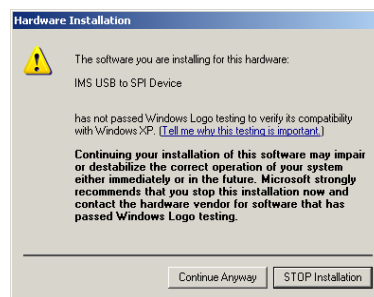

Figure C.6: Windows Logo Compatibility Testing

- 9) The Driver Installation will proceed. When the Completing the Found New Hardware Wizard dialog appears, Click “Finish” (Figure C.7).
10) Upon finish, the Welcome to the Hardware Update Wizard will reappear to guide you through the second part of the install process. Repeat steps 1 through 9 above to complete the cable installation.
11) Your IMS MD-CC300-000 is now ready to use.

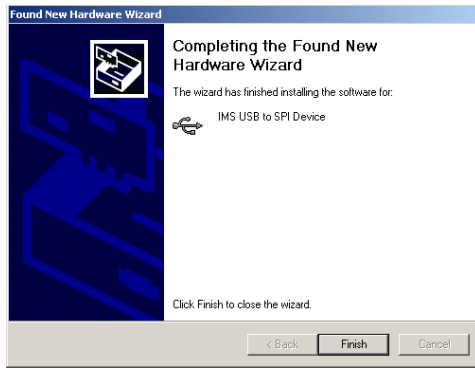

Figure C.7: Hardware Update Wizard Finish Installation

Determining the Virtual COM Port (VCP)

The MD-CC300-000 uses a Virtual COM Port to communicate through the USB port to the MDrive. A VCP is a software driven serial port which emulates a hardware port in Windows.

The drivers for the MD-CC300-000 will automatically assign a VCP to the device during installation. The VCP port number will be needed when IMS Terminal is set up in order that IMS Terminal will know where to find and communicate with your IMS Product.

To locate the Virtual COM Port.

- 1) Right-Click the “My Computer” Icon and select “Properties”.
- 2) Browse to the Hardware Tab (Figure C.8), Click the Button labeled “Device Manager”.
- 3) Look in the heading “Ports (COM & LPT)” IMS USB to SPI Converter Cable (COMx) will be listed (Figure C.9). The COM # will be the Virtual COM Port connected. You will enter this number into your IMS SPI Motor Interface Configuration.

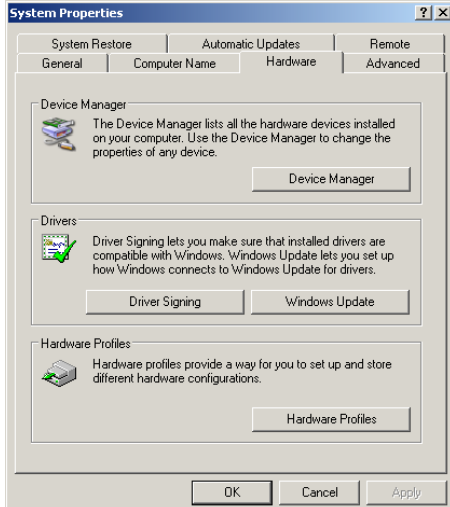

Figure C.8: Hardware Properties

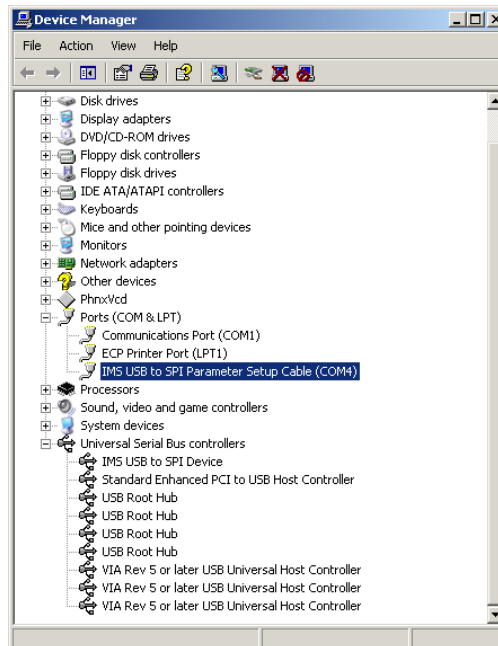

Figure C.9: Windows Device Manager

Adapter

The MD-ADP-M23 Adapter provides connection capability between the MD-CC300-000 Parameter Setup Cable and the 19-Pin M23 connector on the MDriveAC Plus via a single-end cordset. The MD-ADP-M23 has two connectors: a 10-pin IDC, into which the MD-CC300-000 plugs directly, and a 7-Pin Pluggable Terminal Strip into which the Cordset is connected.

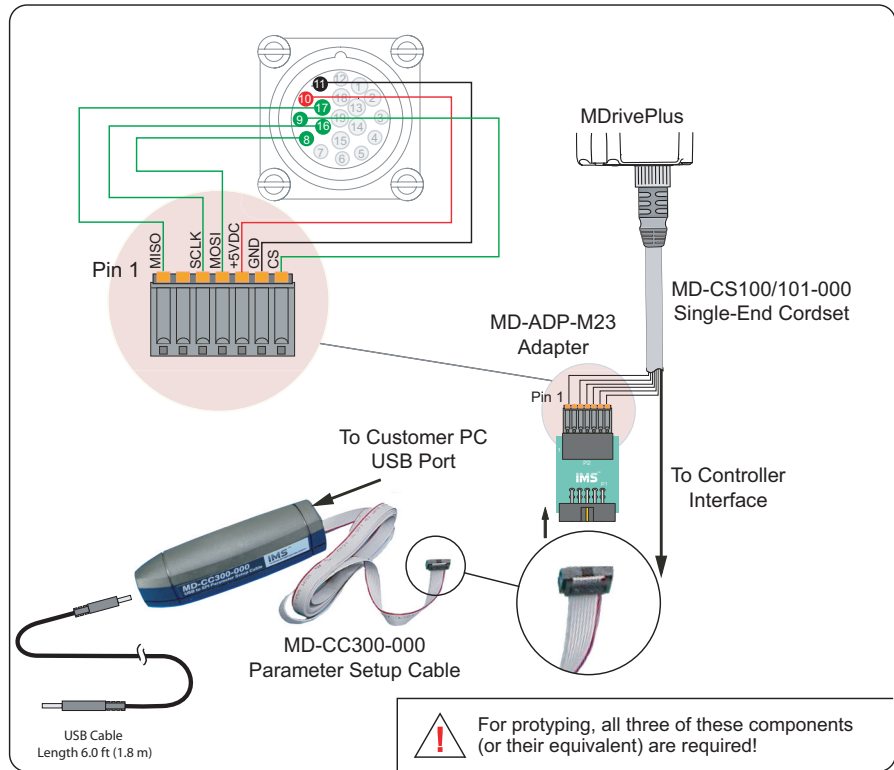

Figure C10: Typical Setup, Adapter and Single-End Cordset

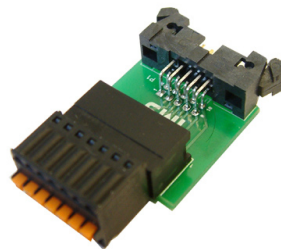

Figure C.11: MD-ADP-M23

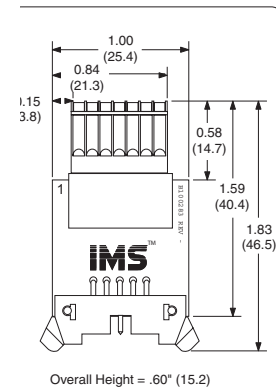

Figure C.12: MD-ADP-M23 Mechanical Specifications

MD-CS10x-000 Cordset

19-pin M23 single-ended cordsets are offered to speed prototyping of the MDriveACPlus Microstepping. Measuring 13.0' (4.0m) long, they are available in either straight or right angle termination. PVC jacketed cables come with a foil shield and unconnected drain wire.

Straight Termination MD-CS100-000

Right Angle MD-CS101-000

Pin Assignment and Wire Colors

P1 - Expanded I/O Configuration			
Cordset Wire Color	Function (Expanded I/O)	Function (Optical Encoder)	MDrive P1
Violet	Opto Reference	Opto Reference	Pin 1
Red	Enable	Enable	Pin 2
Grey	N/C	Index +	Pin 3
Red/Blue	N/C	Channel B +	Pin 4
Green	N/C	Channel B -	Pin 5
Blue	N/C	N/C	Pin 6
Gray/Pink	N/C	Channel A +	Pin 7
White/Green	MOSI	MOSI	Pin 8
White/Yellow	CS	CS	Pin 9
White/Gray	+5 VDC Output	+5 VDC Output	Pin 10
Black	GND	GND	Pin 11
Green/Yellow	N/C	N/C	Pin 12
Yellow/Brown	Direction/Channel B/ Clock Down	Direction/Channel B/ Clock Down	Pin 13
Brown/Green	N/C	Index -	Pin 14
White	N/C	Channel A -	Pin 15
Yellow	SPI Clock	SPI Clock	Pin 16
Pink	MISO	MISO	Pin 17
Gray/Brown	Step Clock/Channel A/ Clock Up	Step Clock/Channel A/ Clock Up	Pin 18
Brown	Fault Output	Fault Output	Pin 19

Table C.1: MD-CS10x-000 Wire Color Chart

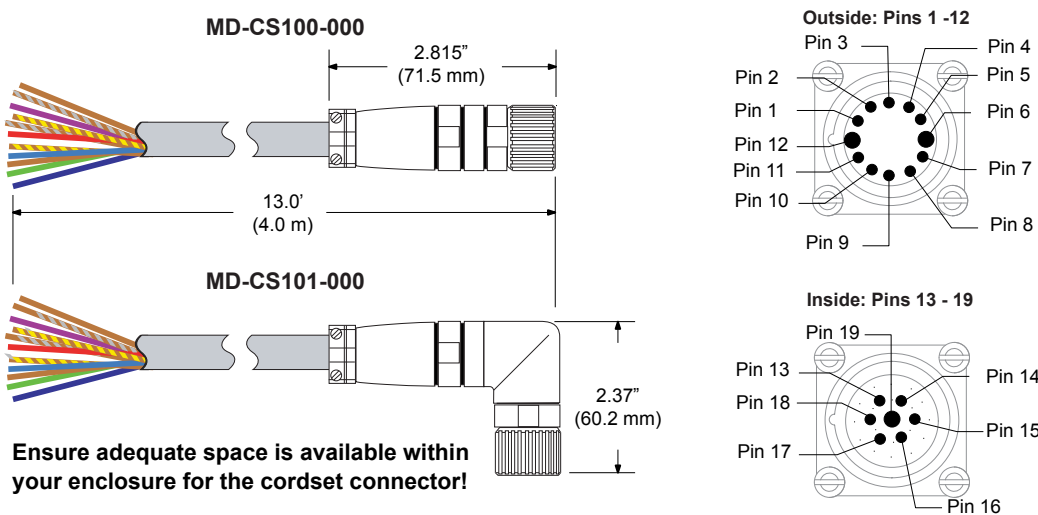

Figure C.13: MD-CS10x-000 Prototype Development Cordset



WARNING! Do not plug or unplug AC Power at the Motor with the power on!



Note: UL Recognition requires the use of the MD-CS20x-000 or Lumberg Equivalent AC Power Cordset.

MD-CS20x-000 Cordset

The single-end three conductor cordsets are used with the MDrive AC. Measuring 13.0' (4.0m) long, they are available in either straight or right angle termination. Euro AC Color Code, Oil-resistant yellow PVC jacket, IP68 and NEMA 6P rated.

Euro AC Cordset	
Euro AC	Euro Cordset Color Code
Pin 1	Yellow/Green
Pin 2	Brown
Pin 3	Blue

Table C.2: Euro AC Wire Color Chart

Straight TerminationMD-CS200-000
 Right Angle TerminationMD-CS201-000

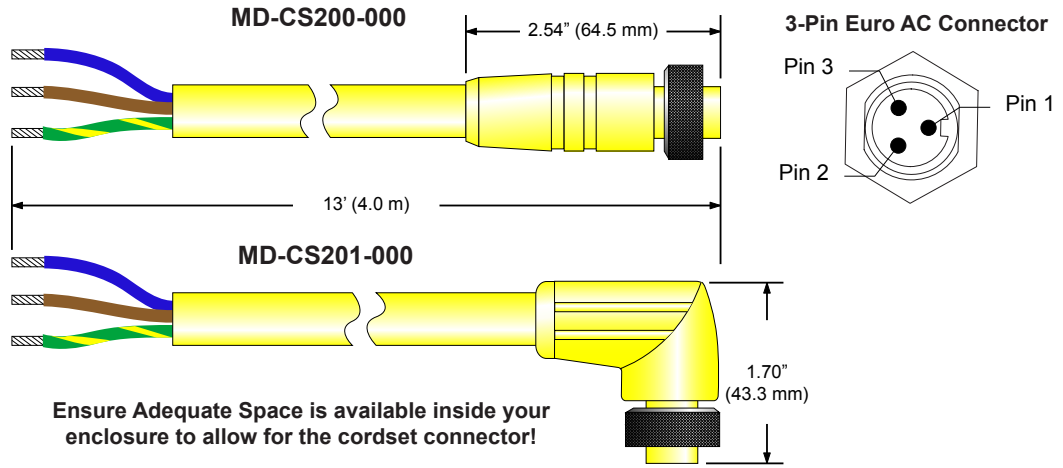

Figure C.14: MD-CS20x-000

APPENDIX D

Interfacing the Internal Differential Optical Encoder

Factory Mounted Encoder

Encoders are available in differential configurations. All encoders have an index mark, except the MDrive42AC 400 line count.

Use of the encoder feedback feature of this product requires a controller such as an IMS MicroLYNX or PLC.

The encoder has a 100 kHz maximum output frequency.

The MDriveAC Plus Microstepping are available with an internal differential optical encoder.

Available line counts are:

MDrive34AC		MDrive42AC	
Line Count	Part Number	Line Count	Part Number
100	EA	100	EA
200	EB	200	EB
250	EC	—	—
256	EW	—	—
400	ED	400	ED
500	EH	500	EH
512	EX	512	EX
1000	EJ	1000	EJ
1024	EY	1024	EY

Table D1: Available Encoder Line Counts and Part Numbers

General Specifications

	Min	Typ	Max	Units
Supply Voltage (VDC)	-0.5		7	Volts
Supply Current	30	57	85	mA
Output Voltage	-0.5		Vcc	Volts
Output Current (Per Channel).....	-1.0		5	mA
Maximum Frequency				100kHz
Inertia		0.565 g-cm ² (8.0 x 10 ⁻⁶ oz-in-sec ²)		
Temperature				
Operating			-40 to +100° C	
Storage.....			-40 to +100° C	
Humidity.....			90% (non-condensing)	

Pin Configuration

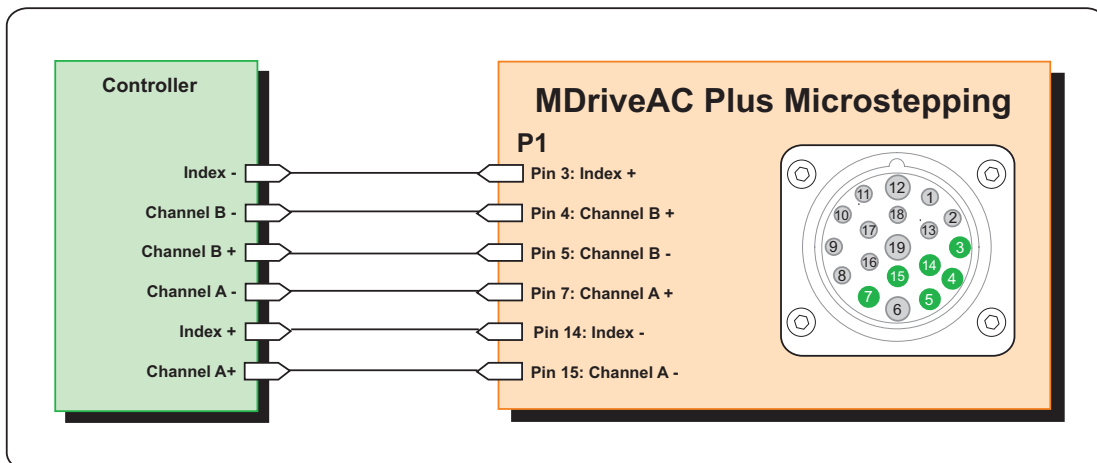

Figure D.1: Internal Differential Encoder Pin Configuration

Encoder Signals

Differential Encoder

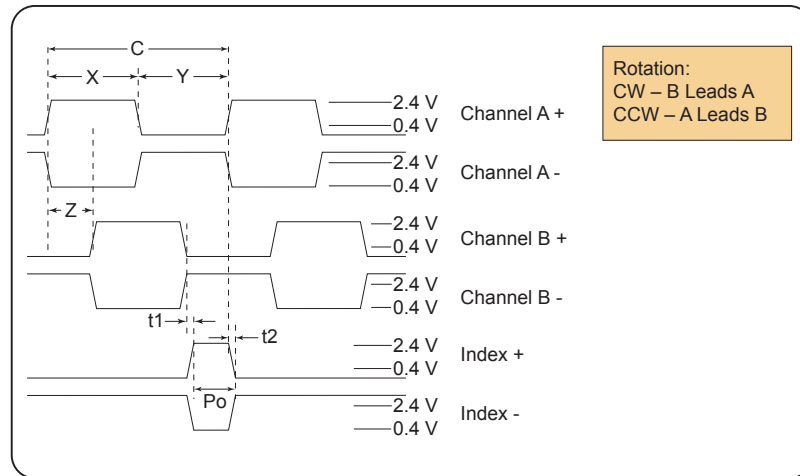

Figure D.2: Differential Encoder Signal Timing

Note: Rotation is as viewed from the cover side.

- (C) One Cycle: 360 electrical degrees ($^{\circ}e$)
- (X/Y) Symmetry: A measure of the relationship between X and Y, nominally $180^{\circ}e$.
- (Z) Quadrature: The phase lag or lead between channels A and B, nominally $90^{\circ}e$.
- (Po) Index Pulse Width: Nominally $90^{\circ}e$.

Characteristics

Parameter	Symbol	Min	Typ	Max	Units
Cycle Error			3	5.5	$^{\circ}e$
Symmetry		130	180	230	$^{\circ}e$
Quadrature		40	90	140	$^{\circ}e$
Index Pulse Width	Po	60	90	120	$^{\circ}e$
Index Rise After CH B or CH A fall	t1	-300	100	250	ns
Index Fall After CH A or CH B rise	t2	70	150	1000	ns

Over recommended operating range. Values are for worst error over a full rotation.

Features

- Screw driven slide offering exceptional linear speed, accurate positioning and long life at a compelling value
- High bidirectional repeatability of up to 50 micro-inches (1.25 microns)
- Positional lead accuracy of 0.0006"/in. – accuracies to 0.0001"/in. available
- Linear speeds not limited by critical screw speed
- Standard leads:
 - 0.10" travel per revolution
 - 0.20" travel per revolution
 - 0.50" travel per revolution
 - 1.00" travel per revolution
- Achieve speeds that exceed 60.0"/second while offering excellent repeatability, accuracy and axial stiffness
- Optional sensor flag kit available for home, limits and general purpose inputs
- Assembly includes a precision aluminum guide and carriage which is driven by a precision rolled stainless steel lead screw
- Sliding contact areas coated with TFE (Teflon) permanent lubrication to offer a low 0.09 coefficient of friction
- Exceptional torsional stiffness and stability
- Standard lengths from 12.0" to 42.0", longer sizes available upon request
- Comes standard with wear-compensating, anti-backlash driven carriage
- Additional passive carriages or slides available to support cantilevered loads
- Easily mountable with provided mounting flange and holes
- Extrusions provided for sensor mounts

MDrive34Plus Linear Slide

Speed-Force Limitations†

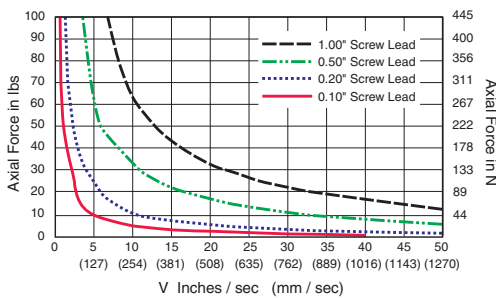

Figure E.1: Speed Force Limitations

†Speed/Force correlating equations:

$$1 \quad \text{Axial Force} = F_{\text{friction}} + F_{\text{acceleration}} + F_{\text{gravity}}$$

$$F_{\text{friction}} = (\text{Weight})(0.09)$$

$$F_{\text{acceleration}} = (\text{Weight})(\text{Acceleration}) / \text{Accel. of gravity}$$

$$F_{\text{gravity}} = 0 \text{ for horizontal application and } 1 \text{ Weight for vertical application}$$

$$2 \quad \text{Torque} = \frac{(\text{Axial Force})(\text{Screw Lead})}{(0.393)(\text{Screw Efficiency})}$$

Force in lbs; Torque in oz-in; Lead in inches/rev

$$3 \quad \frac{\text{Full Steps}}{\text{Second}} = \frac{(200 \text{ Full Steps/Rev})(\text{Velocity})}{\text{Lead}}$$

Lead in inches/rev; Velocity in inches/second

Speed-Torque Curves

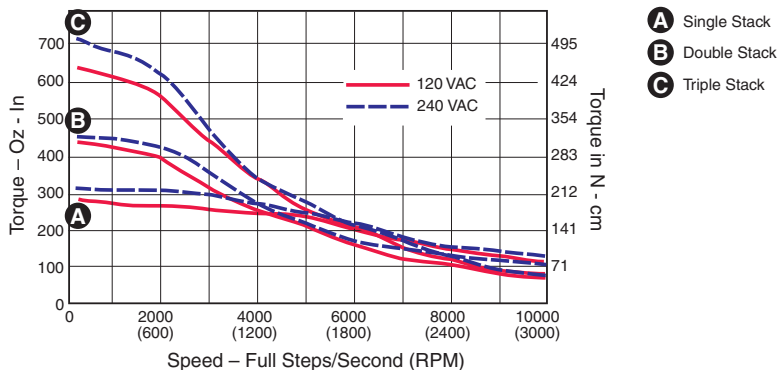

Figure E2: MDrive34Plus Speed Torque Curves

Specifications

Screw Lead	Screw Efficiency	Nom. Screw Diam.	Inch Lead	Max Drag Torque	Life @ ¼ Design Load	Torque to Move Load	Axial Design Load	Screw Inertia
	%	inches (mm)	inches (mm)	oz inch (Nm)	inches (cm)	oz inch/lb (Nm/kg)	lbs (kg)	oz.in.sec ² /inch (Kgm ² /m)
0.10"	40	0.625 (15.9)	0.100 (2.54)	5.0 (0.04)	100,000,000 (254,000,000)	1.3 (0.020)	100 (46)	14.2 x 10 ⁻⁵ (3.9 x 10 ⁻⁵)
0.20"	53	0.625 (15.9)	0.200 (5.08)	6.0 (0.04)	100,000,000 (254,000,000)	2.0 (0.031)	100 (46)	14.2 x 10 ⁻⁵ (3.9 x 10 ⁻⁵)
0.50"	76	0.625 (15.9)	0.500 (12.70)	7.0 (0.05)	100,000,000 (254,000,000)	3.0 (0.047)	100 (46)	14.2 x 10 ⁻⁵ (3.9 x 10 ⁻⁵)
1.00"	81	0.625 (15.9)	1.000 (25.40)	8.5 (0.06)	100,000,000 (254,000,000)	6.5 (0.101)	100 (46)	14.2 x 10 ⁻⁵ (3.9 x 10 ⁻⁵)

Table E.1: MDrive34Plus Linear Slide Specifications

Mechanical Specifications

Dimensions in Inches (mm)

- Motor Mounting Plate
- Heli-Cal Coupling
- Sunx P/N PM-L24 sensor or equivalent (not supplied)
- Optional Sensor Flag Kit for use with U-channel sensor (details below)

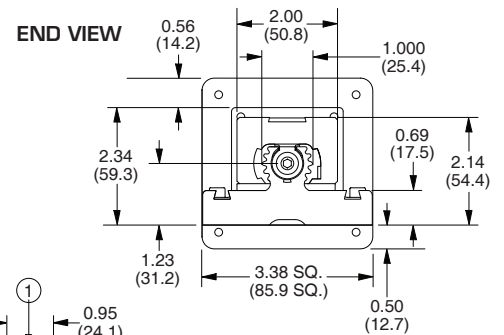

SIDE VIEW

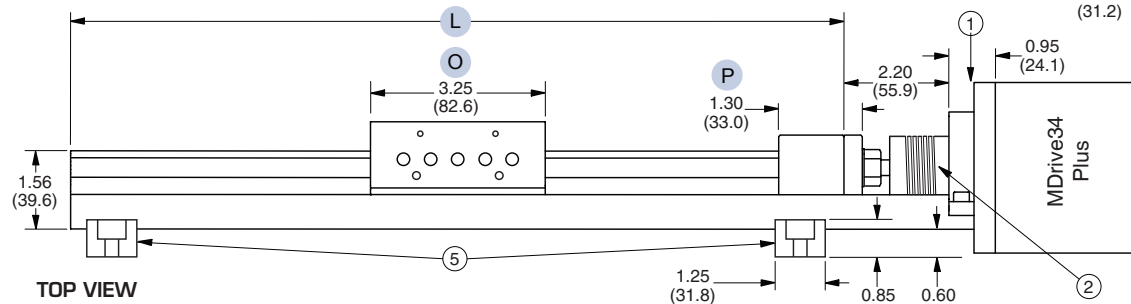

TOP VIEW

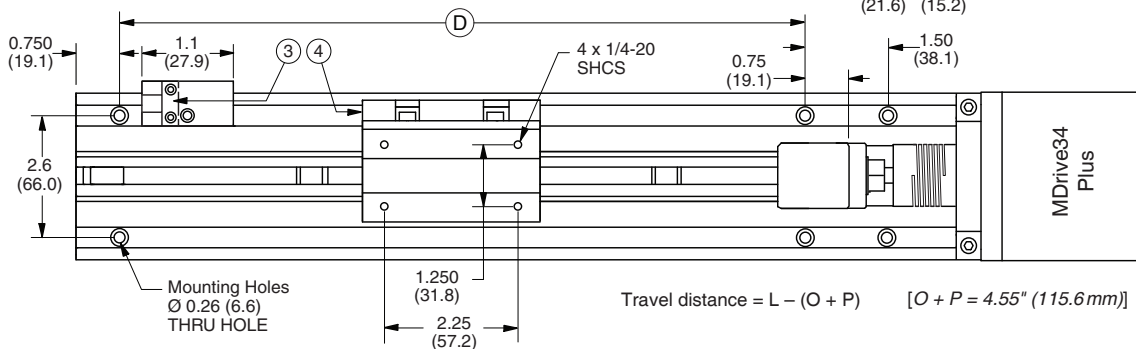

Mounting Holes

Slide Length (L)	Max Hole Distance (D)	Extra Hole Sets (not shown)	Equal Space Between Holes
12"	10.5"	none	10.5"
18"	16.5"	1	8.25"
24"	22.5"	2	7.5"
36"	34.5"	2	11.5"
42"	40.5"	2	13.5"

Sensor Flag Kit Option

P/N RSM10-K Includes:

- A #2-56 X 1/4" Long BHCS (6)
- B Sensor Holder (3)
- C #4-40 X 1/2" Long SHCS (3)
- D Flag for Optical Sensor (1)
- E #6-32 X 1/2" Long SHCS (2)

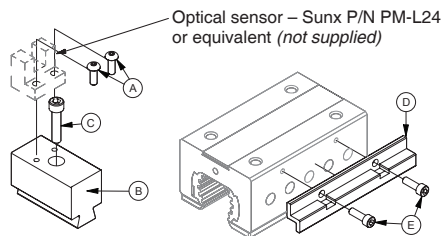

Mounting Bracket Kit Option

P/N RMB10-K Includes:

- F Mounting Bracket (2)
- G #1/4-20 X 3/4" Long SHCS (4)

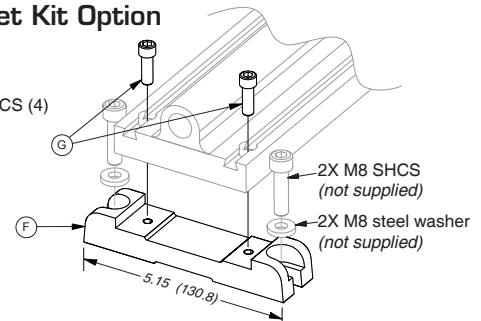

Figure F.3: Mechanical Specifications

WARRANTY

TWENTY-FOUR (24) MONTH LIMITED WARRANTY

Intelligent Motion Systems, Inc. ("IMS"), warrants only to the purchaser of the Product from IMS (the "Customer") that the product purchased from IMS (the "Product") will be free from defects in materials and workmanship under the normal use and service for which the Product was designed for a period of 24 months from the date of purchase of the Product by the Customer. Customer's exclusive remedy under this Limited Warranty shall be the repair or replacement, at Company's sole option, of the Product, or any part of the Product, determined by IMS to be defective. In order to exercise its warranty rights, Customer must notify Company in accordance with the instructions described under the heading "Obtaining Warranty Service."

NOTE: MDrive Motion Control electronics are not removable from the motor in the field. The entire unit must be returned to the factory for repair.

This Limited Warranty does not extend to any Product damaged by reason of alteration, accident, abuse, neglect or misuse or improper or inadequate handling; improper or inadequate wiring utilized or installed in connection with the Product; installation, operation or use of the Product not made in strict accordance with the specifications and written instructions provided by IMS; use of the Product for any purpose other than those for which it was designed; ordinary wear and tear; disasters or Acts of God; unauthorized attachments, alterations or modifications to the Product; the misuse or failure of any item or equipment connected to the Product not supplied by IMS; improper maintenance or repair of the Product; or any other reason or event not caused by IMS.

IMS HEREBY DISCLAIMS ALL OTHER WARRANTIES, WHETHER WRITTEN OR ORAL, EXPRESS OR IMPLIED BY LAW OR OTHERWISE, INCLUDING WITHOUT LIMITATION, **ANY WARRANTIES OF MERCHANTABILITY OR FITNESS FOR ANY PARTICULAR PURPOSE**. CUSTOMER'S SOLE REMEDY FOR ANY DEFECTIVE PRODUCT WILL BE AS STATED ABOVE, AND IN NO EVENT WILL THE IMS BE LIABLE FOR INCIDENTAL, CONSEQUENTIAL, SPECIAL OR INDIRECT DAMAGES IN CONNECTION WITH THE PRODUCT.

This Limited Warranty shall be void if the Customer fails to comply with all of the terms set forth in this Limited Warranty. This Limited Warranty is the sole warranty offered by IMS with respect to the Product. IMS does not assume any other liability in connection with the sale of the Product. No representative of IMS is authorized to extend this Limited Warranty or to change it in any manner whatsoever. No warranty applies to any party other than the original Customer.

IMS and its directors, officers, employees, subsidiaries and affiliates shall not be liable for any damages arising from any loss of equipment, loss or distortion of data, loss of time, loss or destruction of software or other property, loss of production or profits, overhead costs, claims of third parties, labor or materials, penalties or liquidated damages or punitive damages, whatsoever, whether based upon breach of warranty, breach of contract, negligence, strict liability or any other legal theory, or other losses or expenses incurred by the Customer or any third party.

OBTAINING WARRANTY SERVICE

Warranty service may be obtained by a distributor, if the Product was purchased from IMS by a distributor, or by the Customer directly from IMS, if the Product was purchased directly from IMS. Prior to returning the Product for service, a Returned Material Authorization (RMA) number must be obtained. Complete the form at <http://www.imshome.com/rma.html> after which an RMA Authorization Form with RMA number will then be faxed to you. Any questions, contact IMS Customer Service (860) 295-6102.

Include a copy of the RMA Authorization Form, contact name and address, and any additional notes regarding the Product failure with shipment. Return Product in its original packaging, or packaged so it is protected against electrostatic discharge or physical damage in transit. The RMA number MUST appear on the box or packing slip. Send Product to: Intelligent Motion Systems, Inc., 370 N. Main Street, Marlborough, CT 06447.

Customer shall prepay shipping charges for Products returned to IMS for warranty service and IMS shall pay for return of Products to Customer by ground transportation. However, Customer shall pay all shipping charges, duties and taxes for Products returned to IMS from outside the United States.



INTELLIGENT MOTION SYSTEMS, INC.

Excellence in Motion™

www.imshome.com

370 N. Main St., P.O. Box 457
Marlborough, CT 06447 U.S.A.
Phone: 860/295-6102
Fax: 860/295-6107
E-mail: info@imshome.com

TECHNICAL SUPPORT

Phone: 860/295-6102 (U.S.A.)
Fax: 860/295-6107
E-mail: etech@imshome.com

Germany/UK

Phone: +49/7720/94138-0
Fax: +49/7720/94138-2
E-mail: mweber@imshome.com

DISTRIBUTED BY:

IMS UK Ltd.

25 Barnes Wallis Road
Segensworth East
Fareham, Hampshire PO15 5TT
Phone: +44/0 1489-889825
Fax: +44/0 1489-889857
E-mail: mcheckley@imshome.com

IMS ASIA PACIFIC OFFICE

30 Raffles Pl., 23-00 Caltex House
Singapore 048622
Phone: +65/6233/6846
Fax: +65/6233/5044
E-mail: wlee@imshome.com

IMS EUROPE GmbH

Niedereschacherstrasse.54
78083 Dauchingen Germany
Phone: +49/7720/94138-0
Fax: +49/7720/94138-2
E-mail: info@imseuropehome.com

European Sales Management

4 Quai Des Etroits
69005 Lyon, France
Phone: +33/4 7256 5113
Fax: +33/4 7838 1537
E-mail: bmartinez@imshome.com

Germany Sales

Phone: +49/35205/4587-8
Fax: +49/35205/4587-9
E-mail: hruhland@imshome.com

Germany/UK Technical Support

Phone: +49/7720/94138-0
Fax: +49/7720/94138-2
E-mail: mweber@imshome.com

U.S.A. SALES OFFICES

Eastern Region

Phone: 862/208-9742
Fax: 973/661-1275
E-mail: jroake@imshome.com

Central Region

Phone: 260/402-6016
Fax: 419/858-0375
E-mail: dwaksmen@imshome.com

Western Region

Phone: 602/578-7201
E-mail: dweisenberger@imshome.com

IMS MOTORS DIVISION

105 Copperwood Way, Suite H
Oceanside, CA 92054
Phone: 760/966-3162
Fax: 760/966-3165
E-mail: motors@imshome.com

© 2006 Intelligent Motion Systems, Inc. All Rights Reserved. REV R030207
IMS Product Disclaimer and most recent product information at www.imshome.com.



Free Manuals Download Website

<http://myh66.com>

<http://usermanuals.us>

<http://www.somanuals.com>

<http://www.4manuals.cc>

<http://www.manual-lib.com>

<http://www.404manual.com>

<http://www.luxmanual.com>

<http://aubethermostatmanual.com>

Golf course search by state

<http://golfingnear.com>

Email search by domain

<http://emailbydomain.com>

Auto manuals search

<http://auto.somanuals.com>

TV manuals search

<http://tv.somanuals.com>