

ST0524 Snow Thrower

OPERATOR'S MANUAL

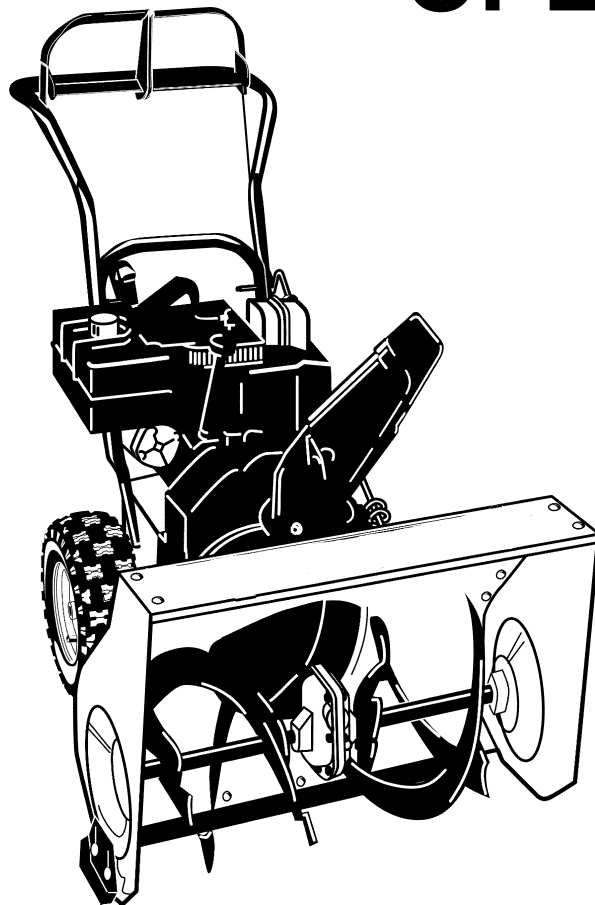

MTF-031072L

FRONTIER
EQUIPMENT™

INTRODUCTION

Congratulations on your purchase of a Frontier Snowthrower. It has been designed, engineered and manufactured to give you the best possible dependability and performance. However, like all mechanical products, your machine will occasionally require adjustment and maintenance. This handbook should be read before operating or performing adjustments on your machine.

The instructions in this Owner's Manual are written for a person with some mechanical ability. Like most service books, not all the steps are described. Steps on how to loosen or tighten fasteners are steps anyone can follow with some mechanical ability. Read and follow these instructions before you use the unit.

Know your product:: If you understand the unit and how the unit operates, you will get the best performance. As you read this manual, compare the illustrations to the unit. Learn the location and the function of the controls. To help prevent an accident, follow the operating instructions and the safety rules. Keep this manual for future reference.

IMPORTANT: Many units are not assembled and are sold in cartons. It is the responsibility of the owner to make sure the assembly instructions in this manual are exactly followed. Other units are purchased in an assembled condition. On assembled units, it is the responsibility of the owner to make sure the unit is correctly assembled. The owner must carefully check the unit according to the instructions in this manual before it is first used.

The warranty, found in this manual, details the coverage and limitations of this product. **Registration of the warranty is necessary and must be preformed by the dealer within sixty (60) days from the date of retail sale or delivery.** The Warranty Registration Form is located on the Frontier website.

RESPONSIBILITY OF THE OWNER

The responsibility of the owners to follow the instructions below.

1. Carefully read and follow the rules for safe operation.
2. Follow all the assembly instructions.
3. Inspect the unit.
4. Make sure that the operator of the unit knows how to correctly use all standard and accessory equipment.
5. Operate the unit only with guards, shields, and other safety items in place and working correctly.
6. Correctly adjust the unit.
7. Service the unit only with authorized or approved replacement parts.
8. Complete all maintenance on the unit.

PRODUCT INFORMATION

The owner must be certain that all the product information is included with this unit.

This information includes the *INSTRUCTION BOOKS*, the *REPLACEMENT PARTS* and the *WARRANTIES*. This information must be included to make sure state laws and other laws are followed.

**Read And Keep This Book For
Future Reference. This Book Contains Important Information On:
*SAFETY, ASSEMBLY, OPERATION AND MAINTENANCE.***

RULES FOR SAFE OPERATION

IMPORTANT



WARNING: Always disconnect the spark plug wire and place it where it cannot make contact with spark plug to prevent accidental starting during: Preparation, Maintenance, or Storage of your snowthrower.



Safe Operation Practices for Snowthrowers As Recommended By: American National Standards Institute.



WARNING:



Engine Exhaust, some of its constituents, and certain vehicle components contain or emit chemicals known to the State of California to cause cancer and birth defects or other reproductive harm.

Battery posts, terminals and related accessories contain lead and lead compounds, chemicals known to the State of California to cause cancer and birth defects or other reproductive harm. WASH HANDS AFTER HANDLING.

IMPORTANT: Safety standards require operator presence controls to minimize the risk of injury. Your snowthrower is equipped with such controls. Do not attempt to defeat the function of the operator presence control under any circumstances.

Training

1. Read the operating and service instruction manual carefully. Be thoroughly familiar with the controls and the proper use of the equipment. Know how to stop the unit and disengage the controls quickly.
2. Never allow children to operate the equipment. Never allow adults to operate the equipment without proper instruction.
3. Keep the area of operation clear of all persons, particularly small children and pets.
4. Exercise caution to avoid slipping or falling especially when operating in reverse.

Preparation

1. Thoroughly inspect the area where the equipment is to be used and remove all doormats, sleds, boards, wires, and other foreign objects.
2. Disengage all clutches before starting the engine (motor).
3. Do not operate the equipment without wearing adequate winter outer garments. Wear footwear that will improve footing on slippery surfaces.
4. Handle fuel with care; it is highly flammable.

MTF-031072L

- a. Use an approved fuel container.
 - b. Never remove fuel tank cap or add fuel to a running engine (motor) or hot engine (motor).
 - c. Fill fuel tank outdoors with extreme care. Never fill fuel tank indoors.
 - d. Replace fuel cap securely and wipe up spilled fuel.
 - e. Never store fuel or snowthrower with fuel in the tank inside of a building where fumes may reach an open flame or spark.
 - f. Check fuel supply before each use, allowing space for expansion as the heat of the engine (motor) and/or sun can cause fuel to expand.
5. For all units with electric starting motors use electric starting extension cords certified CSA/UL. Use only with a receptacle that has been installed in accordance with local inspection authorities.
 6. Adjust the snowthrower height to clear gravel or crushed rock surface.
 7. Never attempt to make any adjustments while the engine (motor) is running (except when specifically recommended by manufacturer).
 8. Let engine (motor) and snowthrower adjust to outdoor temperatures before starting to clear snow.
 9. Always wear safety glasses or eye shields during operation or while performing an adjustment or repair to protect eyes from foreign objects that may be thrown from the snowthrower.

Operation

1. Do not operate this machine if you are taking drugs or other medication which can cause drowsiness or affect your ability to operate this machine.
2. Do not use this machine if you are mentally or physically unable to operate this machine safely.
3. Do not put hands or feet near or under rotating parts. Keep clear of the discharge opening at all times.
4. Exercise extreme caution when operating on or crossing gravel drives, walks or roads. Stay alert for hidden hazards or traffic.
5. After striking a foreign object, stop the engine (motor), remove the wire from the spark plug, thoroughly inspect snowthrower for any damage, and repair the damage before restarting and operating the snowthrower.
6. If the unit should start to vibrate abnormally, stop the engine (motor) and check immediately for the cause. Vibration is generally a warning of trouble.

RULES FOR SAFE OPERATION

7. Stop the engine (motor) whenever you leave the operating position, before unclogging the auger/impeller housing or discharge chute and when making any repairs, adjustments, or inspections.
8. When cleaning, repairing, or inspecting, make certain the auger/impeller and all moving parts have stopped and all controls are disengaged. Disconnect the spark plug wire and keep the wire away from the spark plug to prevent accidental starting.
9. Take all possible precautions when leaving the snowthrower unattended. Disengage the auger/ impeller, stop engine (motor), and remove key.
10. Do not run the engine (motor) indoors, except when starting the engine (motor) and for transporting the snowthrower in or out of the building. Open the outside doors; exhaust fumes are dangerous (containing CARBON MONOXIDE, an ODORLESS and DEADLY GAS).
11. Do not clear snow across the face of slopes. Exercise extreme caution when changing direction on slopes. Do not attempt to clear steep slopes.
12. Never operate the snowthrower without proper guards, plates or other safety protective devices in place.
13. Never operate the snowthrower near enclosures, automobiles, window wells, drop-offs, and the like without proper adjustment of the snow discharge angle. Keep children and pets away.
14. Do not overload the machine capacity by attempting to clear snow at too fast a rate.
15. Never operate the machine at high transport speeds on slippery surfaces. Look behind and use care when backing up.
16. Never direct discharge at bystanders or allow anyone in front of the unit.
17. Disengage power to the collector/impeller when snowthrower is transported or not in use.
18. Use only attachments and accessories approved by the manufacturer of the snowthrower (such as tire chains, electric start kits, ect.).
19. Never operate the snowthrower without good visibility or light. Always be sure of your footing and keep a firm hold on the handles. Walk; never run.
20. Do not over- reach. Keep proper footing and balance at all times.
21. Exercise caution if operating on steep sloping surfaces.
22. This snowthrower is for use on sidewalks, driveways and other ground level surfaces.
23. Do not use the snowthrower on surfaces above ground level such as roofs of residences, garages, porches or other such structures or buildings.

Maintenance And Storage

1. Check shear bolts and other bolts at frequent intervals for proper tightness to be sure the equipment is in safe working condition.
2. Never store the snowthrower with fuel in the tank inside a building where ignition sources are present such as hot water and space heaters, clothes dryers, and the like. Allow the engine (motor) to cool before storing in any enclosure.
3. Always refer to operator's guide instructions for important details if the snowthrower is to be stored for an extended period.
4. Maintain or replace safety and instruction labels, as necessary.
5. Run the snowthrower a few minutes after throwing snow to prevent freeze-up of the auger/impeller.



WARNING: Avoid injury from rotating auger- keep hands, feet, and clothing away.

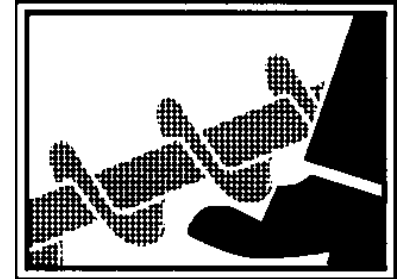

WARNING: Do not use hands to unclog discharge chute.

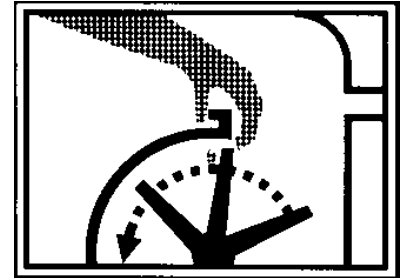

- Stop engine/motor before removing debris.
- Do not walk in front of running machine.
- Do not discharge at bystanders.
- Keep people and pets a safe distance from the machine.
- Before leaving machine, shut off engine/ motor and remove key.

TABLE OF CONTENTS

SAFETY DECALS	6
WARRANTY	7
OWNER'S INFORMATION	7
ASSEMBLY	8
TOOLS REQUIRED FOR ASSEMBLY	8
CONTENTS OF SHIPPING CARTON	8
PARTS BAGS CONTENTS:	8
UNPACKING	9
UPPER HANDLE AND CRANK ASSEMBLY	10
CHECK THE CABLES	10
HOW TO SET THE LENGTH OF THE CABLES	10
SHIFTER LEVER KNOB ASSEMBLY	11
OPERATION	12
ENGINE AND SNOWTHROWER CONTROLS	12
SNOWTHROWER OPERATION	13
WHEEL LOCK OUT PIN	14
HOW TO REMOVE SNOW FROM AUGER	15
HOW TO SET THE DRIFT CUTTERS	15
BEFORE STARTING ENGINE	16
CHECK THE OIL	16
FILL GAS	16
BEFORE STOPPING THE ENGINE	16
TO START ENGINE	17
USE OF ELECTRIC STARTER	18
OPERATING TIPS	20
SERVICE RECOMMENDATIONS	21
MAINTENANCE	22
LUBRICATION	22
ENGINE	24
AUGER HOUSING HEIGHT ADJUSTMENT	25
BELT ADJUSTMENT	26
HOW TO REPLACE THE BELTS	27
BELT GUIDE ADJUSTMENT	29
TRACTION DRIVE CABLE ADJUSTMENT	30
HOW TO ADJUST OR REPLACE THE FRICTION WHEEL	31
AUGER SHEAR BOLT REPLACEMENT	34
TO ADJUST OR REPLACE THE SPARK PLUG	34
STORAGE	35
TROUBLE SHOOTING CHART	36
REPLACEMENT PARTS	38
PARTS SCHEMATICS	39
SPECIFICATIONS	56

OWNER'S INFORMATION

THREE YEAR LIMITED WARRANTY

Murray warrants to the original purchaser of this Frontier Branded Snowthrower that this unit shall be free from defects in material and workmanship under normal use and service for a period of **Three (3) Year** from the date of purchase; however, this warranty does not cover accessories (such as electric starters) and Normal Wear Parts (except as noted below) as the companies that manufacture these items furnish their own warranties and provide service through their authorized field service facilities. For additional information, see the warranties covering these particular parts. If you are uncertain whether your unit contains or is equipped with one or more of these parts, consult your dealer prior to purchase. Subject to the terms and conditions noted in this Limited Warranty, we shall, at our option, repair or replace at no cost to the original purchaser any part covered by this Limited Warranty during the applicable warranty period.

Normal Wear Parts are defined as drive belts, augers, shear pins, tires and headlights. These parts are warranted to be free from defects in material and workmanship as delivered with the product. Any claim for repair or replacement of Normal Wear Parts must be made within thirty (30) days of the date of purchase. No claims involving damage caused from material use, abuse or misuse will be honored.

This Murray **Three (3) Year Limited Warranty** for your Frontier Branded Snowthrower is your exclusive remedy; however, this warranty is void or does not apply to any unit that has been tampered with, altered, misused, abused. If used for commercial and/or professional (non-homeowner) uses, the duration of this warranty is ninety (90) days after the date of purchase. Your warranty does not cover minor mechanical adjustments which are not due to any defect in material or workmanship. For assistance in making such adjustments, consult your Operator's Manual.

The engine on this Frontier Branded Snowthrower is warranted to the original purchaser for only a **Two (2) Year Limited Warranty**. See your engine manual for information regarding the warranty policy and items covered under warranty. See your authorized John Deere/Frontier Dealer for service or replacement parts. **MT**

To make a claim under this Murray **Three (3) Year Limited Warranty** for your Frontier Branded Snowthrower, return the unit (or if authorized in advance, the defective part) along with your proof of purchase to an Authorized John Deere/Frontier Dealer near you. To locate the nearest Authorized John Deere/Frontier Dealer, check the Yellow Page listings in your local telephone directory. If you return the entire unit, John Deere/Frontier will repair all warranty items. If authorize to return the defective part only, John Deere/Frontier will either replace or repair the part. This Murray **Three (3) Year Limited Warranty** for your Frontier Branded Snowthrower gives you specific legal rights, and you may also have other rights which vary from state to state. **This Limited Warranty is given in lieu of all other expressed and implied warranties including the implied warranty of merchantability and warranty of fitness for a particular purpose.** If you need additional information on this written warranty or assistance in obtaining service, contact you local John Deere/Frontier Dealer.

FOR YOUR RECORDS

DATE PURCHASED: _____

MODEL NO: _____

SERIAL NO: _____

STORE WHERE PURCHASED: _____

ADDRESS: _____

CITY: _____ STATE: _____

TELEPHONE : _____

Record this information about your unit so that you will be able to provide it in case of loss or theft.

ASSEMBLY

TOOLS REQUIRED FOR ASSEMBLY

- 1 - Knife
- 2 - 1/2" wrenches (or adjustable wrenches)
- 2 - 9/16" wrenches (or adjustable wrenches)
- 2 - 3/4" wrenches (or adjustable wrenches)
- 1 - 3/8" wrenches (or adjustable wrenches)
- 1 - Pair pliers or screw driver (to spread cotter pin)

CONTENTS OF SHIPPING CARTON

- 1- Snowthrower
- 1- Container of Fuel Stabilizer (Located in Parts Bag)
- 1- Crank Assembly
- 1- Parts Bag

HOW TO MEASURE SCREW SIZE

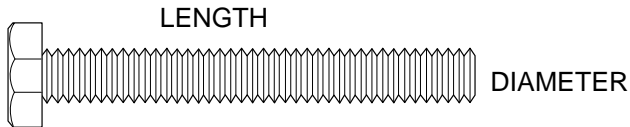

WARNING: Always wear safety glasses or eye shields while assembling snowthrower.

PARTS BAGS CONTENTS:

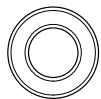
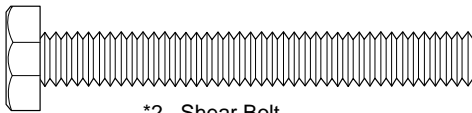

* 2-Spacer

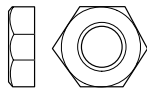

*2- Nut



1 - Shift Lever Knob
(not actual size)

* Non Assembly parts are found in toolbox located on top of belt cover.

ASSEMBLY

Figure 2 shows the snowthrower in the shipping position.

Figure 3 shows the snowthrower completely assembled.

Reference to right and left hand side of the snowthrower is from the operator's position at the handle.

UNPACKING

1. Locate the two tear tabs at the bottom of the carton.
2. Pull the tear tape no more than twelve inches (30.48cm.) at a time. Re-grasp tape next to the carton and pull again. Repeat until all the tape is torn off.
3. After the tape has been completely removed from the carton, remove the carton from the base. Cut all four corners and fold the sides toward the center for easy disposal.
4. Remove the plastic bag that covers the unit.
5. Locate and remove the parts bag.

NOTE: Set the fuel stabilizer aside until adding gasoline to the fuel tank. We recommend that fuel stabilizer is added to the fuel each time that gasoline is added to the fuel tank.

6. For shipping purposes, the **height adjust skids** are attached to the pallet. Remove the **screw** that secures each **height adjust skid** to the pallet. (See Figure 2).
7. Roll the snowthrower off the carton by pulling on the lower handle.

CAUTION: DO NOT back over cables.

8. Remove the packing material from the handle assembly.
9. Cut ties securing the clutch control cables to the lower handle.

NOTE: If the cables have become disconnected from the clutch levers, reinstall the cables as shown in Figure 4.

MTF-031072L

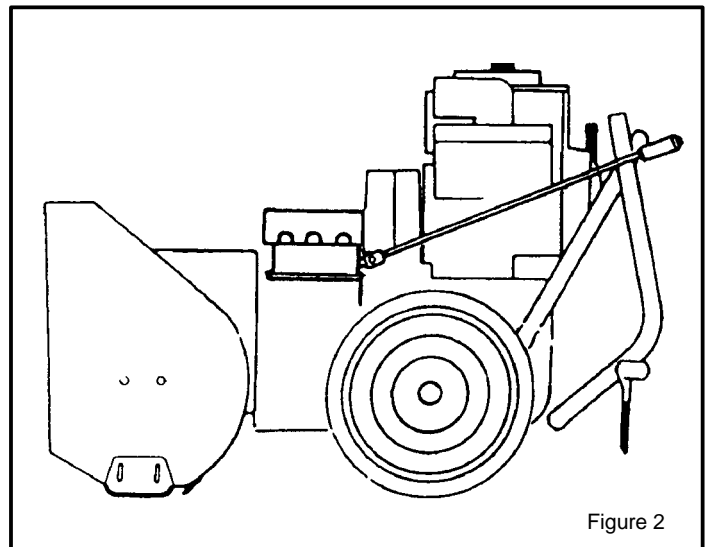

Figure 2

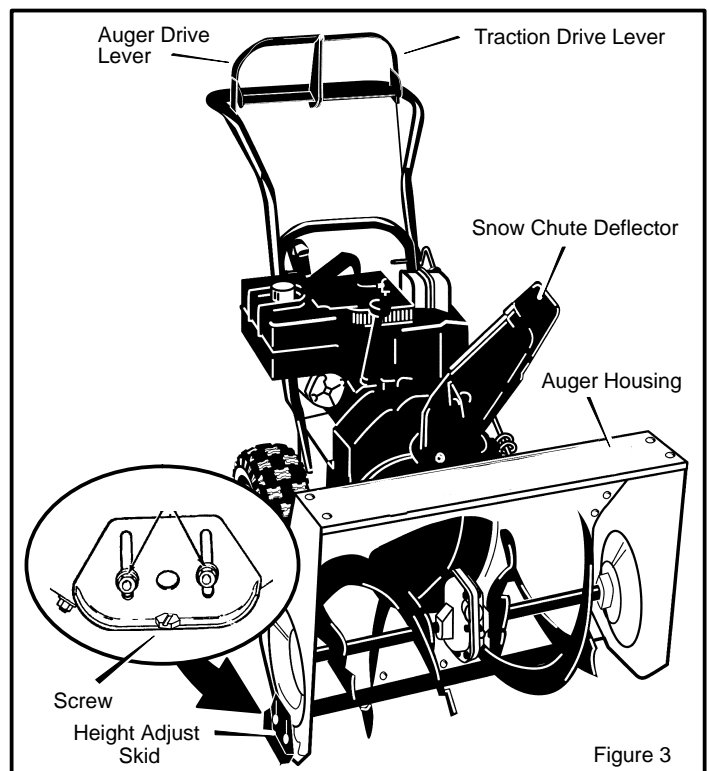

Figure 3

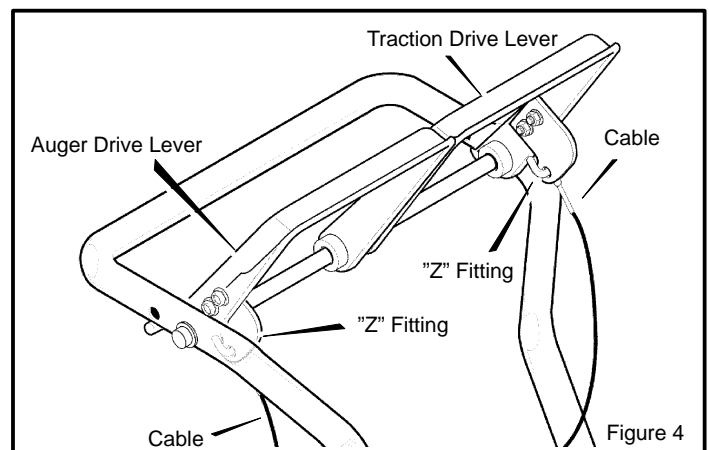

Figure 4

ASSEMBLY

UPPER HANDLE AND CRANK ASSEMBLY

1. Loosen, but do not remove the screws, flatwashers, lockwashers and hex nuts in the upper holes of the lower handle.
2. Remove the fasteners and the crank assembly eyebolt from the lower holes of the lower handle.
3. Raise upper handle into operating position. Upper handle should be to the outside of the lower handle.

NOTE: Make sure the cables are not caught between the upper and lower handle.

4. Install the fasteners and the crank assembly eyebolt that were removed in step 2. DO NOT tighten until all fasteners are in place.
5. Attach the crank rod to the universal joint assembly with the hair pin (see Figure 6).
6. Tighten nut on eye bolt. Make sure eye bolt is properly aligned and the crank can freely rotate.
7. Tighten all handle bolts.

NOTE: Make sure crank does not touch carburetor cover.

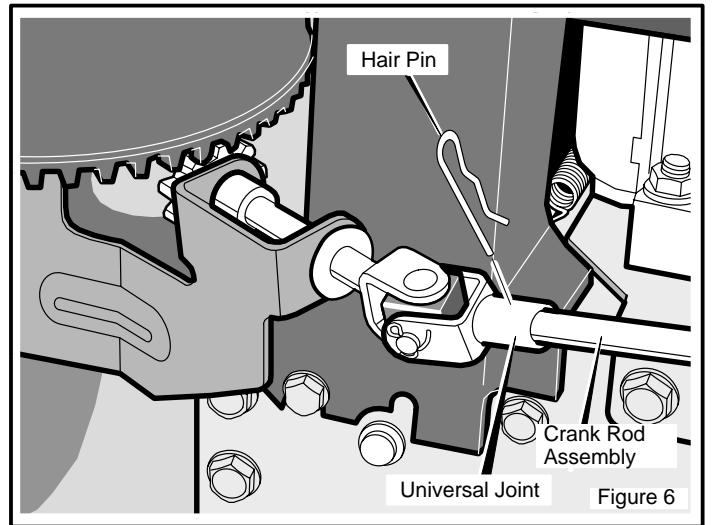
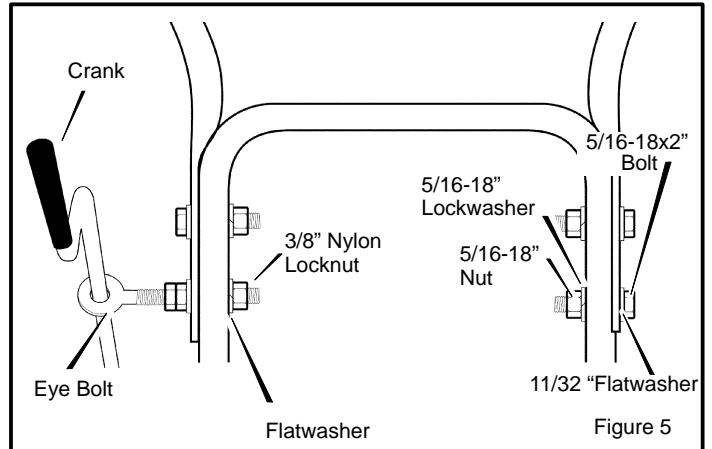

CHECK THE CABLES

1. If control cables have become unattached from motor mount frame, reconnect cables as shown in Figure 7.
2. For cable adjustments, see "How To Check And Adjust The Cables" in the MAINTENANCE section.

HOW TO SET THE LENGTH OF THE CABLES

The cables were adjusted at the factory and no adjustments should be necessary. However, after the handles are put in the operating position, the cables can be too tight or too loose. If an adjustment is necessary, see "How To Check And Adjust The Cables" in the MAINTENANCE section.

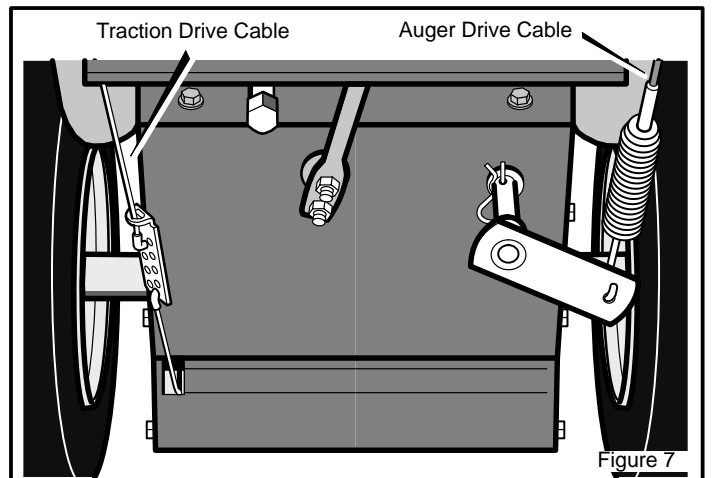

ASSEMBLY

SHIFTER LEVER KNOB ASSEMBLY

1. Thread the **shifter knob** onto the threaded end of the shifter lever until it is snug against the hex nut and the lip is pointed away from the engine (See Figure 8). On some models, the **shifter knob** is attached.
2. Tighten hex nut against the bottom of the shifter lever knob.

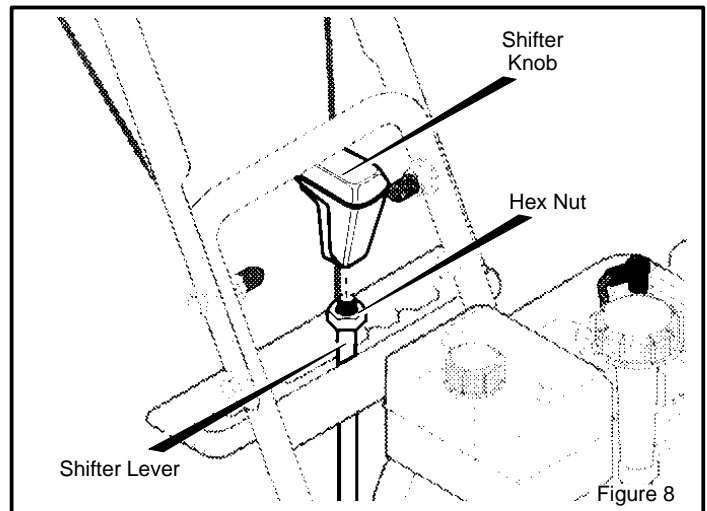

CHECK THE TIRES

The tires were over inflated for shipment. Check the tire pressure in the tires. See the sidewall of the tire for the proper inflation.

IMPORTANT! BEFORE YOU START OPERATING

- Check the fasteners. Make sure all fasteners are tight.
- On electric start models, the unit was shipped with the starter cord plugged into the engine. Before operating, unplug the starter cord from the engine.

NOTE: This snowthrower was shipped WITH OIL in the engine. See "Before Starting Engine" instructions in the Operation section of this manual before starting engine.

OPERATION

READ THIS OWNER'S MANUAL AND SAFETY RULES BEFORE OPERATING YOUR SNOWTHROWER. Compare the illustrations with your SNOWTHROWER to familiarize yourself with the location of various controls and adjustments. Save this manual for future reference.

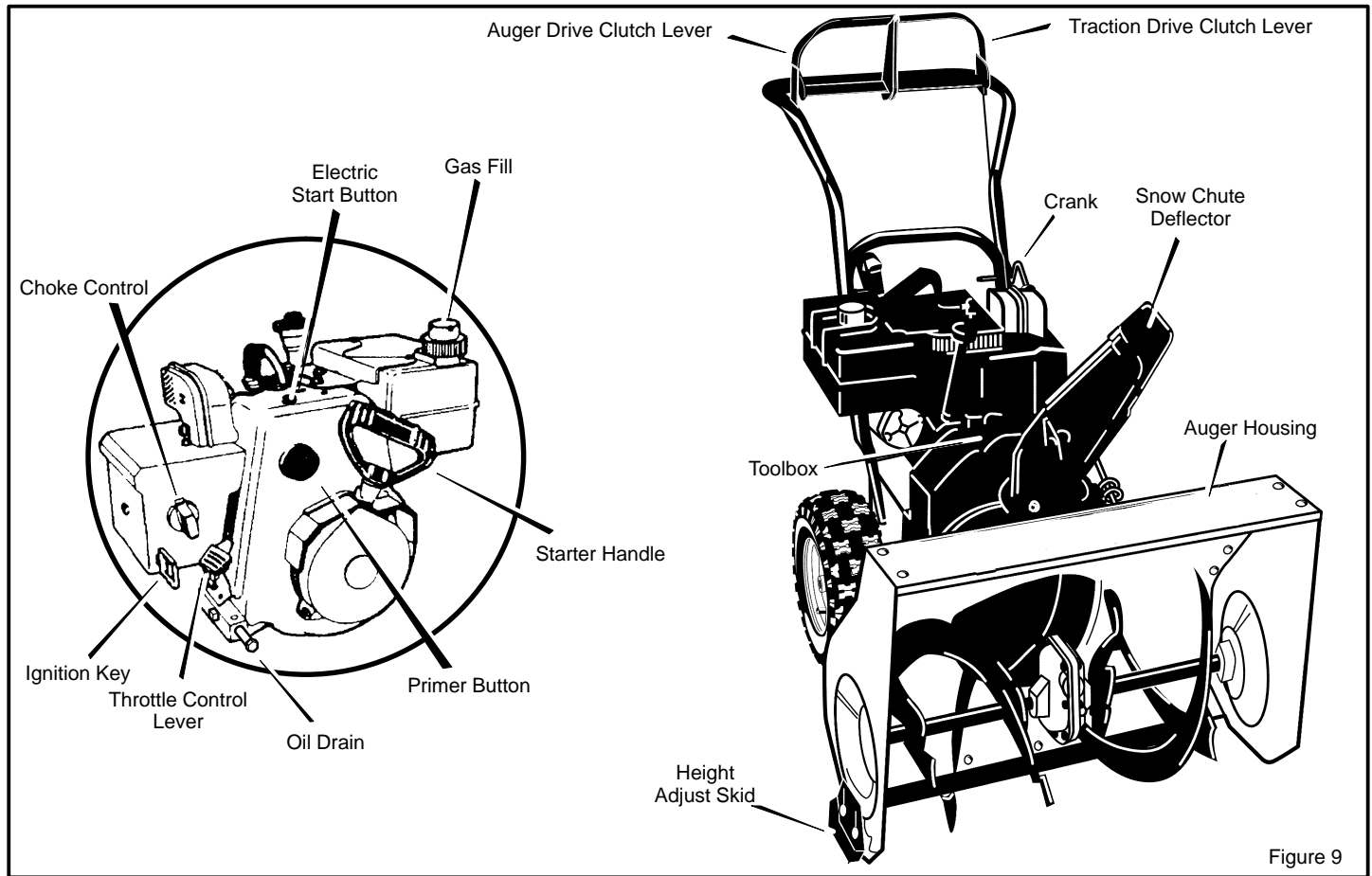

Figure 9

ENGINE AND SNOWTHROWER CONTROLS

ENGINE CONTROLS

Throttle Control Lever - Controls the engine speed.

Choke Control- Use to start a cold engine.

Electric Start Button - Used to start the engine using the 120 volt electric starter.

Prime Button - Used to inject fuel directly into carburetor manifold to insure fast starts in cool weather.

Ignition Key - Must be inserted to start engine. Pull out to stop. Do not turn ignition key.

Starter Handle - Starts the engine manually.

SNOWTHROWER CONTROLS

Speed Select Lever - Allows the operator to use one of six (6) forward and two (2) reverse speeds. To shift, move speed select lever to desired position.

NOTE: Do not move speed select lever while Traction Drive Clutch is engaged. This may result in severe damage to drive system.

Auger Drive Clutch Lever - Used to engage and disengage the auger and impeller. To engage push down, to disengage release.

Traction Drive Clutch Lever - Used to propel snowthrower forward or reverse. Push down to engage, release to disengage.

Snow Chute Deflector - Changes the direction the snow is blown.

Crank - Used to change direction of the snow discharge. Turn handle clockwise to turn chute to right. Turn handle counter clockwise to turn chute to left.

Height Adjust Skid - Used to adjust ground clearance of auger housing.

Toolbox - Spare shear pins, shear bolt wrenches and spacers are located in toolbox.

OPERATION



The operation of any snowthrower can result in foreign objects being thrown into the eyes, which can result in severe eye damage. Always wear safety glasses or eye shields before beginning snowthrower operation. We recommend standard safety glasses or Wide Vision Safety Mask for over spectacles.

SNOWTHROWER OPERATION

The most effective use of the snowthrower will be established by experience, taking into consideration the terrain, wind conditions and building location which will determine the direction of the discharge chute.

NOTE: Do not blow snow toward a building as hidden objects could be blown with sufficient force to cause damage.

TO STOP YOUR SNOWTHROWER

1. To stop throwing snow, release the **auger drive lever**. (see Figure 10).
2. To stop the wheels, release the **traction drive lever**.
3. To stop the engine, push the **throttle control lever** to off and pull out the **ignition key**.

TO CONTROL SNOW DISCHARGE

1. Rotate the **crank** to set the direction (left to right) of the discharge chute (see Figure 9).
2. Adjust the **snow chute deflector**. Loosen the **wing nut** on the side of the **snow chute deflector**. Raise the **snow chute deflector** for more distance or lower for less distance. Tighten **wing nut**. (see Figure 11).

HOW TO MOVE FORWARD AND BACKWARD

1. Start the engine. See "To Start Engine" in the Operation section.

NOTE: Always release the traction drive lever before moving the speed select lever.

2. Ground speed is determined by snow conditions. Set the **speed select lever** (see Figure 12) in one of the following positions.

- | | |
|-----|--------------------------------|
| 1-2 | Wet, Heavy, Slushy, Extra Deep |
| 3 | Moderate |
| 4-5 | Very Light |
| 6 | Transport Only |

IMPORTANT: Before operating, make sure the area in front of snowthrower is clear of bystanders or obstacles.

3. Engage the **traction drive lever** (see Figure 10). As the snowthrower starts to move, maintain a firm hold on the handles and guide the snowthrower along the cutting path. Do not attempt to push the snowthrower.

4. To stop forward motion, release the **traction drive lever**.
5. To move the snowthrower backwards, move the **speed select lever** into either first or second reverse position and engage the **traction drive lever**.

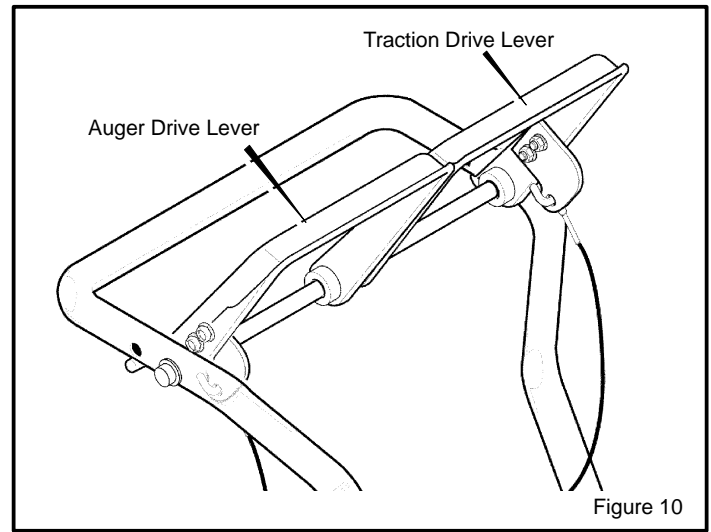

Figure 10

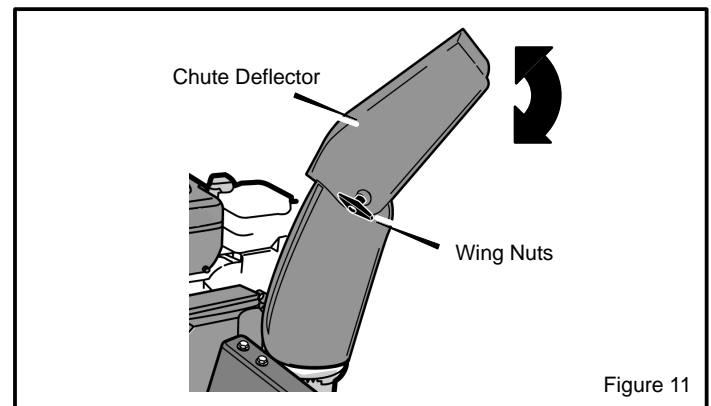

Figure 11

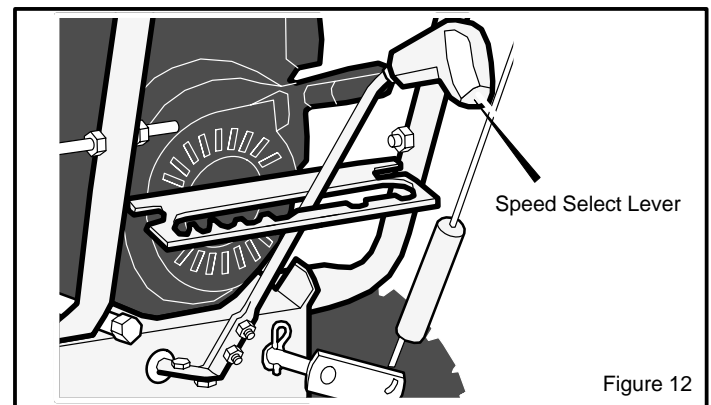

Figure 12

OPERATION

TO THROW SNOW

1. Push down the auger driver lever (right hand). See Figure 10.
2. To stop throwing snowl, release the auger drive lever.

NOTE: When clearing wet, heavy snow, it is recommended that the ground speed of the unit be reduced, maintain full throttle and do not attempt to clear the full width of the unit.

For additional operating instructions see "Operating Tips" in the Operation section.

WARNING: Read Owner's Manual before operating machine. This machine can be dangerous if used carelessly.

Never operate the snowthrower without all guards, covers, and shields in place.

Never direct discharge towards windows or allow bystanders near machine while engine is running.

Stop the engine whenever leaving the operating position.

Disconnect spark plug before unclogging the impeller housing or the discharge chute and before making repairs or adjustments.

When leaving the machine, remove the ignition key.

To reduce the risk of fire, keep the machine clean and free from spilled gas, oil and debris.



WARNING: Never run engine indoors or in an enclosed, poor ventilated area. Engine exhaust contains CARBON MONOXIDE, an ORDERLESS and DEADLY GAS.

Keep hands, feet, hair and loose clothing away from any moving parts on engine and snowthrower.

Temperature of muffler and nearby areas can exceed 150° F (66° C). Avoid these areas.

DO NOT allow children or young teenagers to operate or be near snowthrower while it is operating.

WHEEL LOCK OUT PIN

1. The right wheel is secured to the axle with a klik pin. This unit was shipped with this klik pin in the locked position. (Figure 13).

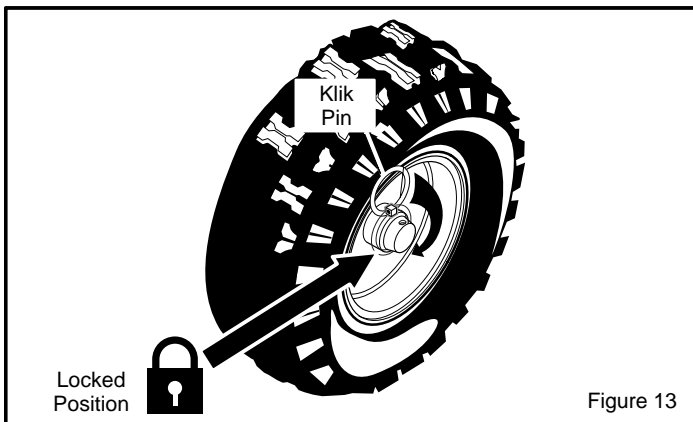

Figure 13

2. For ease of maneuverability when lighter conditions prevail, remove klik pin from wheel locked position and insert into single wheel drive (unlocked) position (Figure 14). Make sure that the klik pin is in the single wheel drive position of the axle only and not through the locked position.

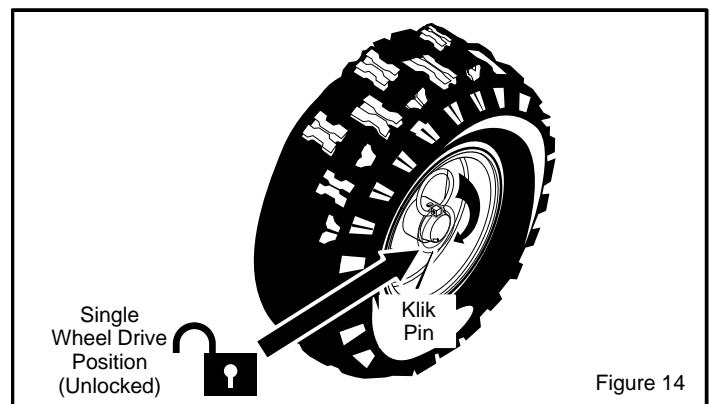

Figure 14

NOTE: Check tire pressure. See side of tire for maximum inflation. Do not exceed listed maximum pressure.

OPERATION

HOW TO REMOVE SNOW FROM AUGER



WARNING: Do not attempt to remove snow or debris that may become lodged in auger without taking the following precautions:

A cleaning stick is attached to the top of the auger housing. Use the cleaning stick to remove snow from the auger housing.

- Release auger drive lever.
- Move throttle lever to stop position.
- Remove (do not turn) ignition key.
- Disconnect spark plug wire.
- Do not place your hands in the auger or discharge chute. Use the cleaning stick to remove snow.

HOW TO SET THE DRIFT CUTTERS

(OPTIONAL ACCESSORY ON SOME MODELS)

Drift cutters are used to cut a path through snow deeper than the auger housing.

1. Loosen the **wingnuts** that secure the **drift cutters** to the auger housing (see Figure 15).
2. Raise the **drift cutters** to the desired height.
3. Tighten the **wingnuts**.

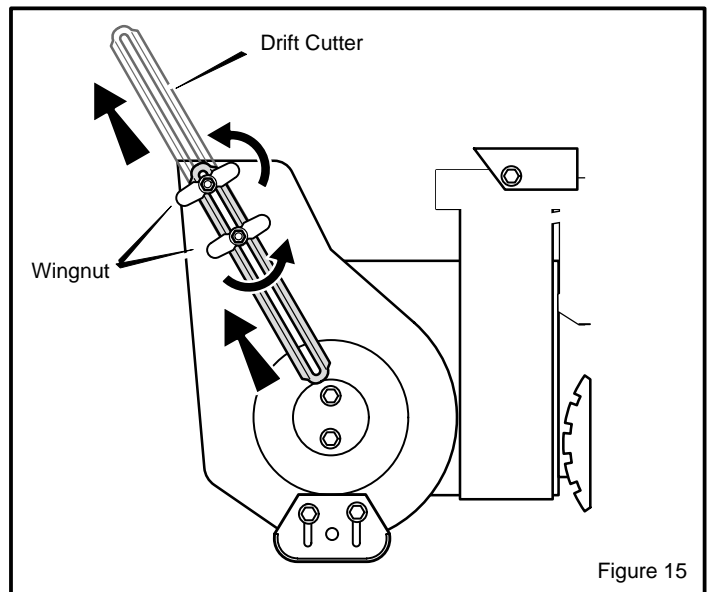

OPERATION

BEFORE STARTING ENGINE

Check the oil

NOTE: The engine was shipped from the factory filled with oil. Check the level of the oil. Add oil as needed.

1. Make sure the unit is level.
2. Remove the oil fill cap/dipstick. Check the oil.

NOTE: Do not check the level of the oil while the engine runs.

3. If necessary, add oil until the oil reaches the FULL mark on the oil fill/cap dipstick (see Figure 16). Do not add too much oil.

NOTE: For extreme cold operating conditions of 0°F (-18°C) and below, use a synthetic 0W30 motor oil for easier starting.

NOTE: S.A.E. 5W30 motor oil may be used to make starting easier in areas where the temperature is 20°F (-7°C) to 0°F (-18°C).

NOTE: SEE CHART FOR OIL RECOMMENDATION

TEMPERATURE	TYPE OF OIL
0°F (-18°C) and above	S.A.E. 5W30
0°F (-18°C) and below	synthetic 0W30

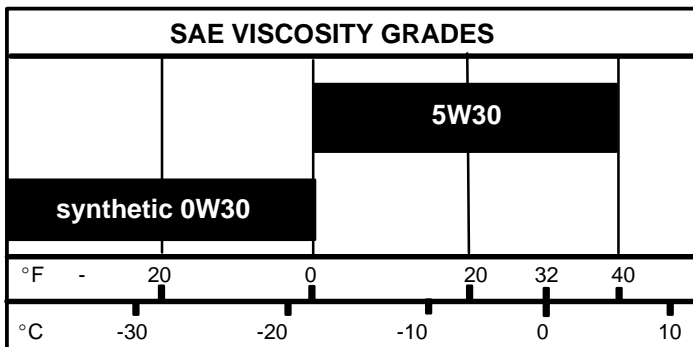

FILL GAS

1. Fill the fuel tank with a fresh, clean, unleaded regular, unleaded premium, or reformulated automotive gasoline only. **DO NOT** use leaded gasoline.

NOTE: Winter grade gasoline has higher volatility to improve starting. Be certain container is clean and free from rust or other foreign particles. Never use gasoline that may be stale from long periods of storage in the container.

CAUTION: DO NOT use gasoline containing any amount of alcohol as it can cause serious damage to the engine or significantly reduce the performance.

2. Check to make sure that spark plug is tightened securely into engine and spark plug wire is attached to spark plug. If torque wrench is available, torque plug to 18-23 ft-lbs.



WARNING: Gasoline is flammable. Always use caution when handling or storing gasoline. Do not add gasoline to the fuel tank while snowthrower is running, hot, or when snowthrower is in an enclosed area. Keep away from open flame, electrical sparks and **DO NOT SMOKE** while filling the fuel tank. Never fill the fuel tank completely; but fill the fuel tank to within 1/4-1/2 inch (6.5-12.5 mm) from the top to provide space for the expansion of the fuel. Always fill fuel tank outdoors and use a funnel or spout to prevent spilling. Make sure to wipe up any spilled fuel before starting the engine.

Store gasoline in a clean, approved container, and keep the cap in place on the container. Keep gasoline in a cool well ventilated place; never in the house. Never buy more than a 30 day supply of gasoline to assure volatility. Gasoline is intended to be used as a fuel for internal combustion engines; therefore, do not use gasoline for any other purpose. Since many children like the smell of gasoline, keep it out of their reach because the fumes are dangerous to inhale, as well as being explosive.

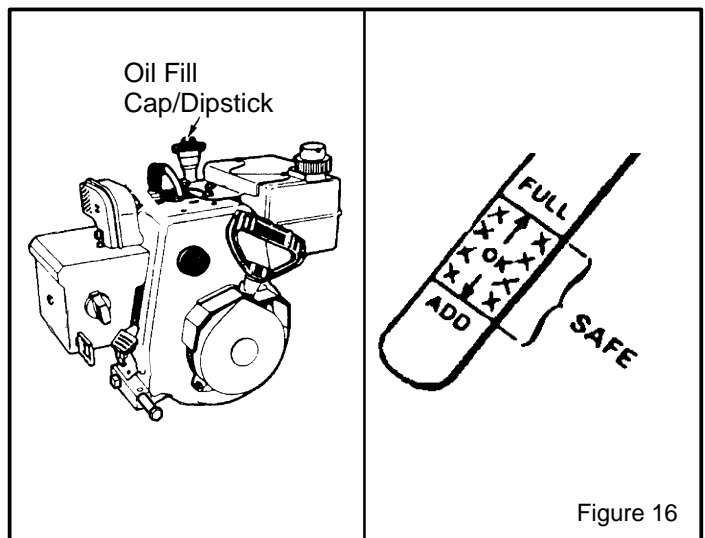

Figure 16

BEFORE STOPPING THE ENGINE

Run the engine for a few minutes to help dry off any moisture on the engine.

To help avoid possible freeze-up of the starter, proceed as follows:

Recoil Starter

With the engine running, pull the starter rope with a rapid continuous full arm stroke three or four times.

NOTE: The normal sound made by pulling the starter rope will not harm the engine or the starter.

Electric Starter

1. Connect the power cord to the switchbox and then to a wall outlet.
2. With the engine running, push the starter button and spin the starter for several seconds.

OPERATION

NOTE: The normal sound made by spinning the starter will not harm the engine or the starter.

3. Disconnect the power cord from the receptacle first and then from the switchbox.

TO START ENGINE

Be sure that engine has sufficient oil.

The snowthrower engine is equipped with a recoil starter.

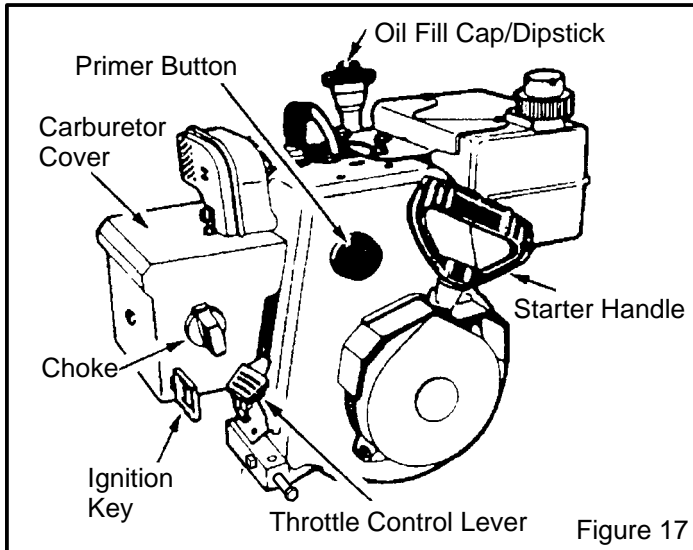

COLD ENGINE START (RECOIL STARTER) (SEE FIGURE 17)

(Engine has not been run recently.)

1. Be sure auger drive clutch lever and traction drive clutch lever are in the disengaged (RELEASED) position.
2. IN TEMPERATURES ABOVE 0°F (-18°C)
Move throttle control to "FAST" position.
IN TEMPERATURES BELOW 0°F (-18°C)
Move throttle control to "1/2 THROTTLE" position. Before engaging auger drive clutch lever allow engine to idle for five minutes to allow engine oil to warm. Failure to allow engine oil to warm can cause damage to engine.
3. Insert key into ignition slot. Make sure it snaps into place (Figure 17). Do not turn key.
4. Rotate choke knob to the on position.
5. Push the primer button as follows:
Above 50° F (10° C), DO NOT PRIME.
From 50° F (10° C) to 15°F (-10° C), PUSH TWO TIMES.
Below 15° F (-10° C), PUSH FOUR TIMES.
NOTE: Cover the vent hole when as you push the primer. Remove your finger from the primer vent hole between pushes.
6. Pull starter handle (Figure 17) rapidly, and allow to re-wind slowly while maintaining firm grip on handle.
7. As engine warms up move choke lever to "1/2 choke" position. When engine does not run smoothly, move choke lever to the off position.

NOTE: Allow the engine to warm up for several minutes before blowing snow in temperatures below 0°F (-18° C).

8. Run engine at or near top speed.
9. To stop engine, move throttle control lever to stop position. Remove key. Do not turn key.

WARM ENGINE START (RECOIL STARTER)

(Engine still warm from recent running.)

1. Be sure auger drive clutch lever and traction drive clutch lever are in the disengaged (RELEASED) position.
2. IN TEMPERATURES ABOVE 0°F (-18°C)
Move throttle control to "FAST" position.
IN TEMPERATURES BELOW 0°F (-18°C)
Move throttle control to "1/2 THROTTLE" position. Allow engine to idle at "1/2 Throttle" for five minutes to allow engine oil to warm before engaging auger drive clutch lever. Failure to allow engine oil to warm can cause damage to engine.
3. Insert key into ignition slot. Make sure it snaps into place (Figure 17). Do not turn key.
4. CHOKE KNOB must be in the off position. Do not use primer button.
5. Pull starter handle (Figure 17) rapidly, and allow to re-wind slowly while maintaining firm grip on handle.
6. If engine fails to start after a reasonable number of starting attempts, rotate choke knob to the on position and repeat instruction number 5.
7. As engine warms up, move the choke lever to the "1/2 choke" position. When engine does not run smoothly, move choke lever to the off position.

NOTE: Allow the engine to warm up for several minutes before blowing snow in temperatures below 0°F (-18° C).

8. Run engine at or near top speed.
9. To stop engine, move throttle control lever to stop position. Remove ignition key. Do not turn the ignition key.

To help prevent possible freeze-up of recoil starter and engine controls, proceed as follows after each snow removal job.

1. With engine running, pull starter rope hard with a continuous full arm stroke three or four times. Pulling of starter rope will produce a loud clattering sound. This is not harmful to the engine or starter.
2. With engine not running, wipe all snow and moisture from carburetor cover in area of control levers. Also move control levers backward and forward several times.

IMPORTANT: After each use of the snowthrower, stop the engine, remove the ignition key, remove all accumulated snow from the snowthrower and wipe clean. Store the snowthrower in a protected area.

NOTE: Never cover snowthrower while engine and exhaust area are still warm.

OPERATION

USE OF ELECTRIC STARTER

On models so equipped



WARNING: The electric starter is equipped with a three-wire power cord and plug designed to operate on 120 volt AC house hold current. The power cord must be properly grounded at all times to avoid the possibility of electric shock which can cause injury to the operator. Follow all instructions carefully as set forth below:

Make sure your house has a three-wire grounded system. If you are not sure, ask a licensed electrician. If your house does not have a three-wire grounded system, do not use this electric starter under any condition.

If your house has a three-wire grounded system but a three hole receptacle is not available to connect the electric starter, have a three-hole receptacle installed by a licensed electrician.



WARNING: To connect a 120 volt power cord, always connect the power cord first to the switch box located on the engine and then plug the other end into a three-hole grounded receptacle.



WARNING: To disconnect the power cord, always unplug the end connected to the three-hole grounded receptacle first.

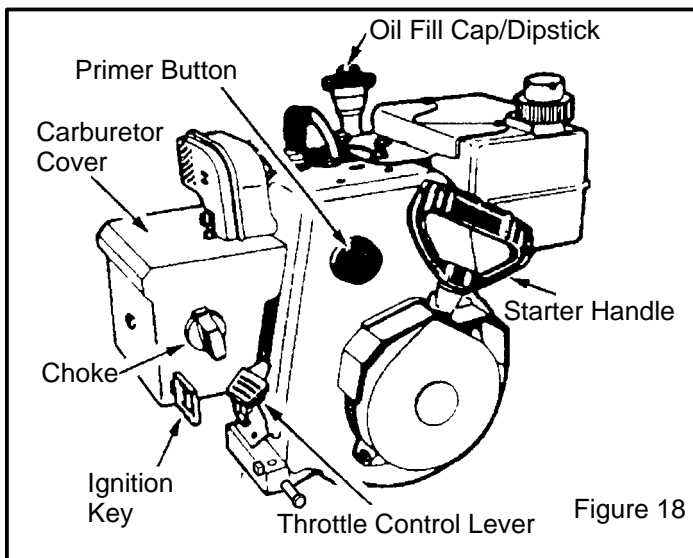

Figure 18

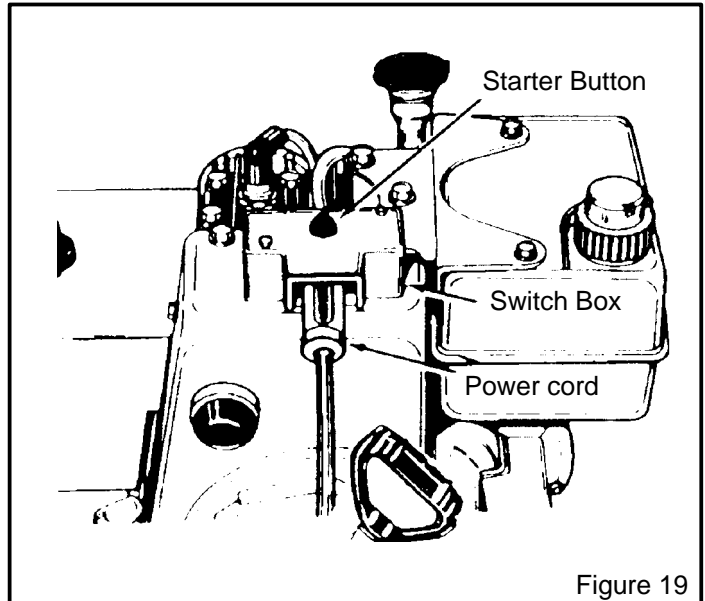

Figure 19

COLD ENGINE START (ELECTRIC STARTER) (SEE FIGURE 18 AND FIGURE 19)

(Engine has not been run recently.)

NOTE: When using the 120 volt electric starter, do not push the primer button.

1. Be sure auger drive clutch lever and traction drive clutch lever are in the disengaged (RELEASED) position.
2. IN TEMPERATURES ABOVE 0°F (-18°C)
Move throttle control to "FAST" position.
IN TEMPERATURES BELOW 0°F (-18°C)
Move throttle control to "1/2 THROTTLE" position. Allow engine to idle at "1/2 Throttle" for five minutes to allow engine oil to warm before engaging auger drive clutch lever. Failure to allow engine oil to warm can cause damage to engine.
3. Insert key into ignition slot. Make sure it snaps into place (Figure 18). Do not turn key.
4. CHOKE KNOB must be in the off position.
5. Connect POWER CORD to SWITCH BOX (Figure 19).
6. Plug other end of POWER CORD into a three-hole, GROUNDED 120 VOLT, AC receptacle. (See WARNING at beginning of these instructions).

NOTE: Cover vent hole when pushing primer. Remove finger from primer vent hole between pushes.

7. Push the primer button as follows:
Above 50° F (10° C), DO NOT PRIME.
From 50° F (10° C) to 15° F (-10° C), PUSH TWO TIMES.
Below 15° F (-10° C), PUSH FOUR TIMES.
8. START ENGINE:

OPERATION

- a. Push STARTER BUTTON (Figure 19) to engage starter motor and crank engine.
- b. Rotate CHOKE KNOB to the on position while cranking engine.

NOTE: The electric starter is thermally protected. If overheated, the electric starter will stop automatically and can only be restarted when it has cooled to a safe temperature. A wait of approximately five to ten minutes is required.

- c. When engine starts, release the STARTER BUTTON and rotate the CHOKE KNOB gradually to the off position.
 - d. If engine falters, rotate the CHOKE KNOB immediately to the on position and then gradually to the off position.
 - e. Disconnect the POWER CORD from receptacle first, and then from the SWITCH BOX.
9. When the engine starts, release the starter button and move choke lever to "1/2 choke" position. When engine does not run smoothly, move choke lever to the off position.

NOTE: Allow the engine to warm up for several minutes before blowing snow in temperatures below 0°F.

10. Run engine at or near top speed.
11. To stop engine, move throttle control lever to stop position. Remove key. Do not turn key.

If, after following the preceding instructions, your engine fails to start, have it checked by a John Deere/Frontier dealer.

WARM ENGINE START (ELECTRIC STARTER)

(Engine still warm from recent running.) Proceed with the following instructions.

NOTE: Warm engine may start without choking.

1. Be sure auger drive clutch lever and traction drive clutch lever are in the disengaged position, "RELEASED".

2. IN TEMPERATURES ABOVE 0°F (-18°C)
Move throttle control to "FAST" position.
IN TEMPERATURES BELOW 0°F (-18°C)
Move throttle control to "1/2 THROTTLE" position. Allow engine to idle at "1/2 Throttle" for five minutes to allow engine oil to warm before engaging auger drive clutch lever. Failure to allow engine oil to warm can cause damage to engine.
3. Insert key into ignition slot. Make sure it snaps into place (Figure 17). Do not turn key.
4. CHOKE KNOB must be in the off position.
5. Connect the POWER CORD to the SWITCH BOX (Figure 19).
6. Plug other end of POWER CORD into a three hole, GROUNDED 120VOLT, AC receptacle (See "WARNING" at beginning of these instructions).
7. START ENGINE:
 - a. Push STARTER BUTTON (Figure 19) to engage starter motor and crank engine.
 - b. While cranking, rotate the CHOKE KNOB on the engine to the on position.

NOTE: The electric starter is thermally protected. If overheated, the electric starter will stop automatically and can only be restarted when it has cooled to a safe temperature. A wait of approximately five to ten minutes is required.

- c. When the engine starts, release the STARTER BUTTON and rotate the CHOKE KNOB gradually to the off position.
 - d. If the engine falters, rotate CHOKE KNOB immediately to the on position and then gradually to the off position.
 - e. Disconnect the POWER CORD from the receptacle first and then from the SWITCH BOX.
8. Run the engine at or near top speed.
 9. To stop the engine, move the throttle control lever to the "Stop" position. Remove the ignition key. Do not turn key.

If after following the preceding instructions, your engine fails to start, have the engine checked by a John Deere/Frontier dealer.

NOTE: Do not lose the ignition key. Key the ignition key is a safe place. The engine will not start without the ignition key.

OPERATION

OPERATING TIPS

1. For optimum snowthrower efficiency, adjust ground speed, not the throttle. REMEMBER - if the wheels slip, forward speed will be reduced. The engine is designed to deliver optimum performance at full throttle and must be run at this power setting at all times.
2. Most efficient snowblowing is accomplished when snow is removed immediately after it falls.
3. For complete snow removal, slightly overlap each swath previously taken.
4. Snow should be discharged downwind whenever possible.
5. For normal usage, set the skids one-eighth inch (3 mm) below the scraper bar. For extremely hard-packed snow surfaces, the skids may be adjusted upward to insure cleaning efficiency.
6. On gravel or crushed rock surfaces, the skids should be set at 1-1/4 inch (32 mm) below the scraper bar (see To Adjust Skid Height, in the MAINTENANCE section in this manual). Rocks and gravel must not be picked up and thrown by the machine.
7. After the snowblowing job has been completed, allow the engine to idle for a few minutes, to melt snow and ice accumulated on the engine.
8. Remove ice and snow accumulation from the entire snowthrower to prevent obstructions and possible damage when snowthrower is subsequently operated.
9. Before starting snowthrower, always inspect augers and impeller for ice accumulation and/or debris, which could result in snowthrower damage.
10. Check oil level before every start. fill to "SAFE" indication prior to operating snowthrower.

To help avoid possible freeze-up of starter, proceed as follows:

Recoil Starter:

With engine running, pull starter rope with a rapid continuous full arm stroke three (3) or four (4) times.

NOTE: The unusual sound made by pulling starter rope will not harm the engine or the starter.

Electric Starter:

1. Connect the "POWER CORD" to the "SWITCH BOX" and then to a 120 volt AC receptacle.
2. With engine running, push the "STARTER BUTTON" and spin the starter for several seconds.

NOTE: The unusual sound made by spinning the starter rope will not harm the engine or the starter.

3. Disconnect the "POWER CORD" from the receptacle first and then from the "SWITCH BOX".

SERVICE RECOMMENDATIONS

SERVICE RECOMMENDATIONS								
PROCEDURE	FIRST 2 HOUR	BEFORE EACH USE	OFTEN	EVERY 5 HOURS	EVERY 10 HOURS	EVERY 25 HOURS	BEGINNING EACH SEASON	BEFORE STORAGE
S N O W T H R O W E R	Tighten all screws and nuts	√		√			√	
	Check Traction Clutch Cable Adjustment (See Cable Adjustment)	√					√	
	Check Auger clutch Cable Adjustment (See Cable Adjustment)	√					√	
	Lubricate Chains and Hex Shaft						√	√
E N G I N E	Oil, Check		√		√		√	
	Oil, Change	√				√	√	

The warranty on this snowthrower does not cover items that have been subjected to operator abuse or negligence. To receive full value from the warranty, operator must maintain snowthrower as instructed in this manual. The following **Service Recommendations** is supplied to assist operator to properly maintain snowthrower. This is a check list only. Adjustment referred to will be found in the MAINTENANCE section of this manual.

AFTER EACH USE

1. Check for any loose or damaged parts.
2. Tighten any loose fasteners.
3. Check and maintain the auger.
4. After each use, remove all snow and slush off the snowthrower to prevent freezing of auger or controls.
5. Check controls to make sure they are functioning properly.
6. If any parts are worn or damaged, replace immediately.

MAINTENANCE

Some adjustments will need to be made periodically to properly maintain your snowthrower.

All adjustments in the MAINTENANCE section of this manual should be checked at least once each season.

SNOW BLOWER

Auger and Traction Drive Belts should be adjusted after the first 2 to 4 hours of use, again about mid-season and twice each season thereafter (See To Adjust Belts paragraph in the MAINTENANCE section).

AS REQUIRED

Auger Gear Box

The auger gear box is lubricated at the factory and should not require additional lubrication.

If for some reason the lubricant should leak out, or if the auger gear box has been serviced, add Lubriplate GR132 Grease or equivalent. Maximum 3-1/4 ounces, (92 grams) should be used.

Remove filler plug (Figure 20), once a year. If grease is visible, do not add. If grease is not visible, use a piece of fine wire, like a dipstick to check if there is grease in the gear box. Mobilux EP1 and Shell Aldania EP1 are suitable equivalents.

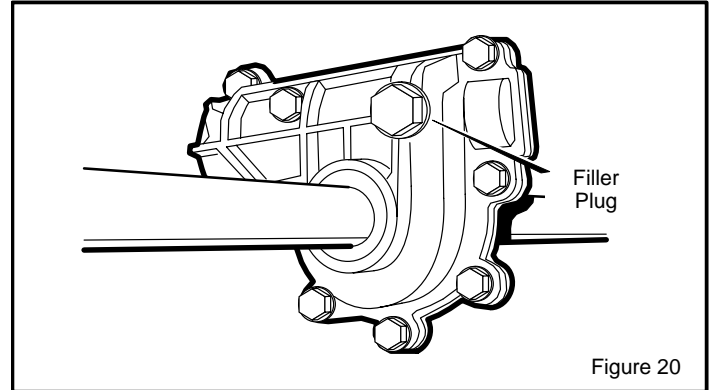

LUBRICATION AT STORAGE

Bearings and bushings

All bearings and bushings are lifetime lubricated and require no maintenance.

Hex shaft and chains

For storage, the hex shaft should be wiped with a cloth lightly moistened with motor oil to prevent rusting (see Figure 22).

For storage, the chains should be lubricated with a chain type lube. (see Figure 22).

NOTE: Any greasing or oiling of the above mentioned components can cause contamination of the rubber friction wheel. If the disc drive plate or friction wheel come in contact with grease or oil damage to rubber friction wheel will result .

If grease or oil comes into contact with the disc drive plate or friction wheel, make sure to clean plate and wheel thoroughly with a alcohol base solvent.

MAINTENANCE

LUBRICATION - EVERY 25 HOURS

Chute Rotation Gear

Lubricate the **chute rotation gear** with automotive type oil. (see Figure 21).

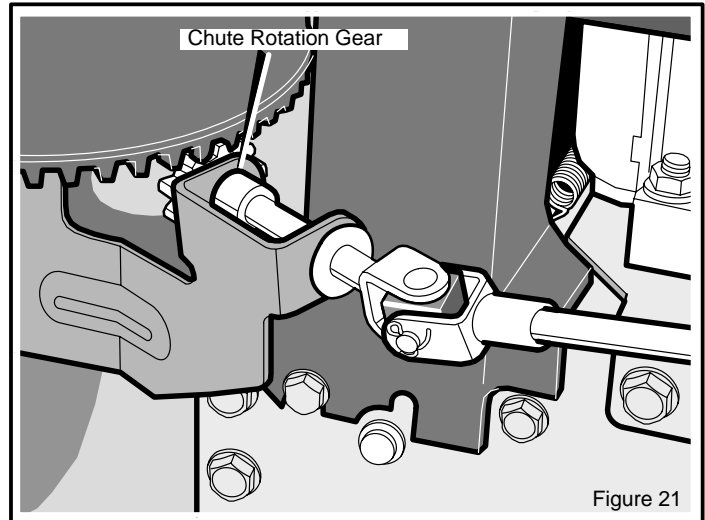

Chains

1. Position speed selector lever in first (1) forward gear.
2. Stand the snowthrower up on the auger housing end.

NOTE: When the crank case is filled with oil, do not leave the snowthrower standing up on the auger housing for an extended period of time.

3. Remove the bottom panel.

4. Lubricate the **chains** with a chain type lubricant.
5. Wipe the **hexshaft and sprockets** with 5W30 motor oil.
NOTE: Clean all excess grease or oil found on the rubber friction wheel or the disc drive plate.
CAUTION: Do not allow grease or oil to contact the rubber friction wheel or the disc drive plate.
6. Install the bottom panel.

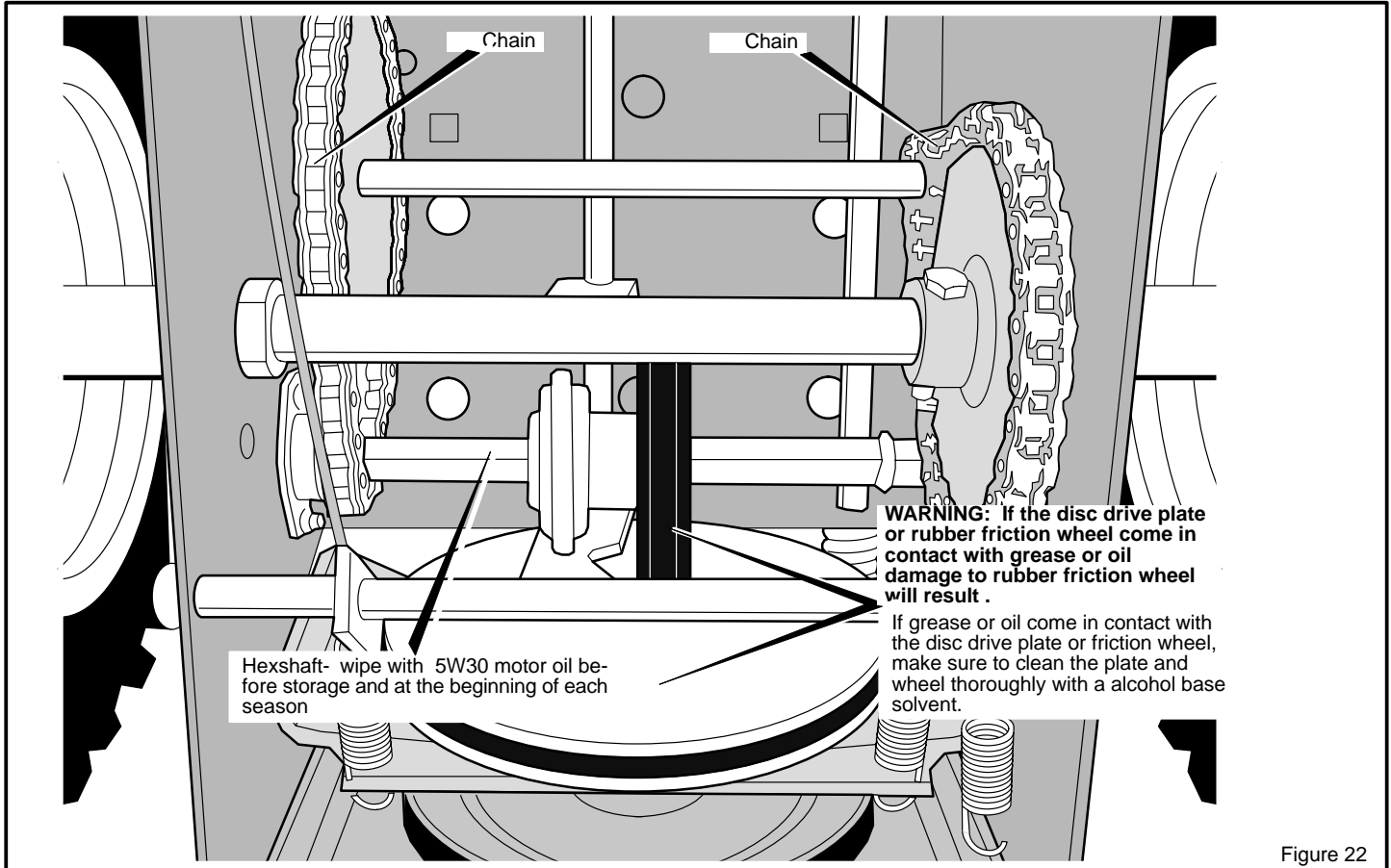

MAINTENANCE

ENGINE

Check Crankcase Oil Level before starting engine and after each 5 hours of continuous use (see Figure 23). Add proper motor oil as required.

NOTE: Overfilling the engine can affect performance. Tighten the oil fill cap securely to prevent leakage.

Change Oil every 25 hours of operation or at least once a year, even if the snowthrower is not used for twenty-five hours. Use a clean, high quality detergent oil. Fill the crank case to FULL line on dipstick (see Figure 23). Be sure original container is marked: A.P.I. service "SF" or higher. Do not use SAE10W40 oil (as it may not provide proper lubrication). See Chart for oil recommendations.

To Drain Oil - Position snowthrower so that the oil drain plug is lowest point on engine. Remove oil drain plug and oil fill cap and drain oil into a suitable container (Figure 24).

NOTE: Oil will drain more freely when warm.

Replace oil drain plug and tighten securely. Refill crank case with proper motor oil or as indicated in the preceding paragraphs of this section.

TEMPERATURE	TYPE OF OIL
0° F (-18° C) and above	S.A.E. 5W30
0° F (-18° C) and below	synthetic 0W30

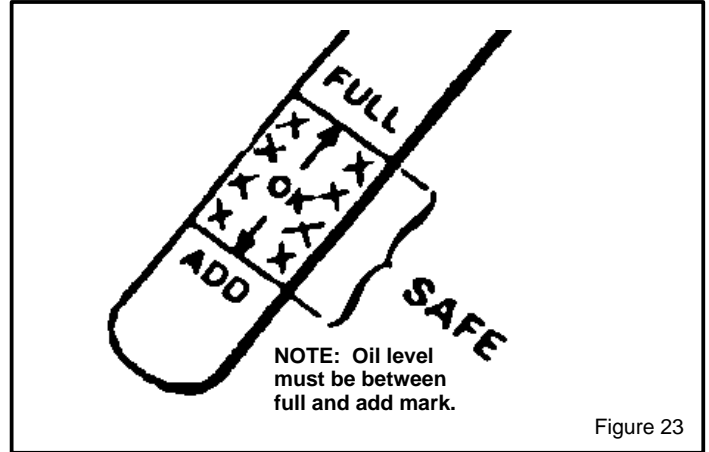
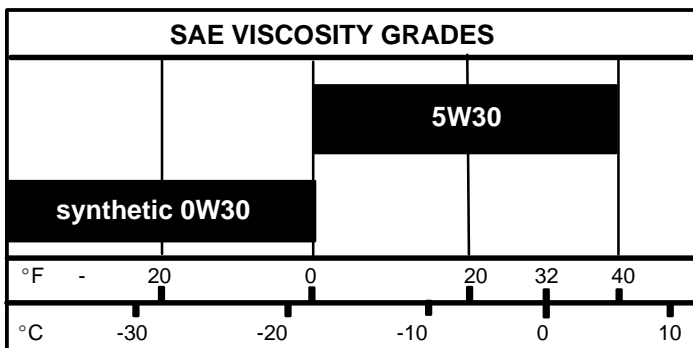

Figure 23

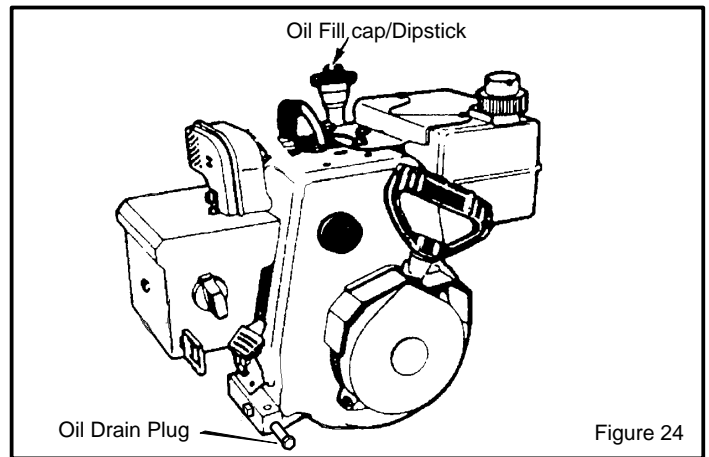

Figure 24

MAINTENANCE



WARNING: Always turn unit off, remove ignition key and disconnect the spark plug wire before making any repairs or adjustments.

AUGER HOUSING HEIGHT ADJUSTMENT

TO ADJUST SCRAPER BAR

After considerable use, the metal scraper bar will have a definite wear pattern. The scraper bar in conjunction with the skids should always be adjusted to allow one-eighth of an inch (3 mm) between the scraper bar and the sidewalk or area to be cleaned.

To adjust the scraper bar, proceed as follows:

1. Position the snowthrower on a level surface.
2. Loosen the carriage bolts and nuts securing the scraper bar to the auger housing.
3. Adjust the scraper bar to the proper position. Tighten the carriage bolts and nuts, insuring that the scraper bar is parallel with the working surface.
4. For extended operation, the scraper bar may be reversed. If the scraper bar must be replaced because of wear, remove the carriage bolts and nuts and install a new scraper bar.

TO ADJUST SKID HEIGHT

This snowthrower is equipped with two height adjust skids, secured to the outside of the auger housing. These elevate the front of the snowthrower.

When removing snow from a hard surface area such as a paved driveway or walk, adjust the skids up to bring the front of the snowthrower down.

When removing snow from rock or uneven construction, raise the front of the snowthrower by moving the skids down. This will help to prevent rocks and other debris from being picked up and thrown by the augers.

To adjust skids, proceed as follows:

1. Place a block (equal to height from ground desired) under scraper bar near but not under skid.
2. Loosen skid mounting nuts (Figure 25) and push the skid down until it touches the ground. Retighten mounting nuts.
3. Set skid on other side at same height.

NOTE: Make sure that snowthrower is set at same height on both sides.



WARNING: Be certain to maintain proper ground clearance for your particular area to be cleared. Objects such as gravel, rocks or other debris, if struck by the impeller, may be thrown with sufficient force to cause personal injury, property damage or damage to the snowthrower.

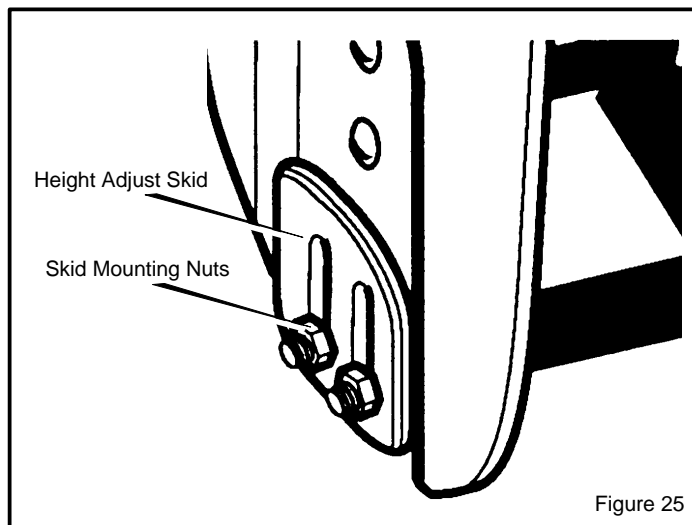

Figure 25

MAINTENANCE

BELT ADJUSTMENT

Traction Drive Belt

The traction drive belt has constant spring pressure and does not require an adjustment. If the traction drive belt is slipping, replace the belt. See "How To Replace The Belts" in the Maintenance section.

Auger Drive Belt

If your snowthrower will not discharge snow, check the control cable adjustment. If it is correct, then check the condition of the auger drive belt. If it is damaged or loose, replace it (see Belt Replacement in this section of the manual).

1. Disconnect spark plug wire.
2. Remove **screw** from **belt cover**. Remove **belt cover** (see Figure 26).
3. Loosen nut on auger idler pulley and move auger idler pulley towards belt about 1/8 inch (3 mm) (see Figure 29).
4. Tighten nut.
5. Have someone engage auger drive clutch. Check tension on belt (opposite idler pulley). Belt should deflect about 1/2 inch (12.5 mm) with moderate pressure (Figure 27). You may have to move idler pulley more than once to obtain the correct tension.
6. Reinstall belt cover.
7. Whenever belts are adjusted or replaced, the cables will need to be adjusted. (See Cable Adjustment in this section of the manual).
8. Attach the spark plug wire.

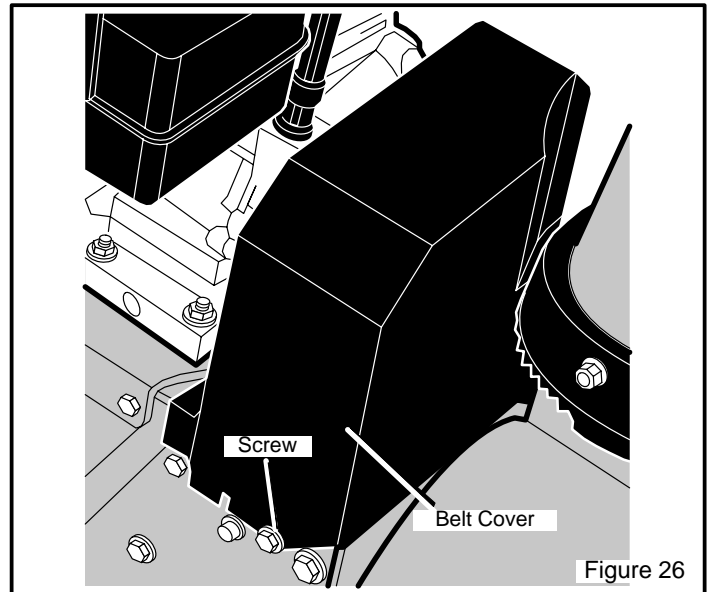

Figure 26

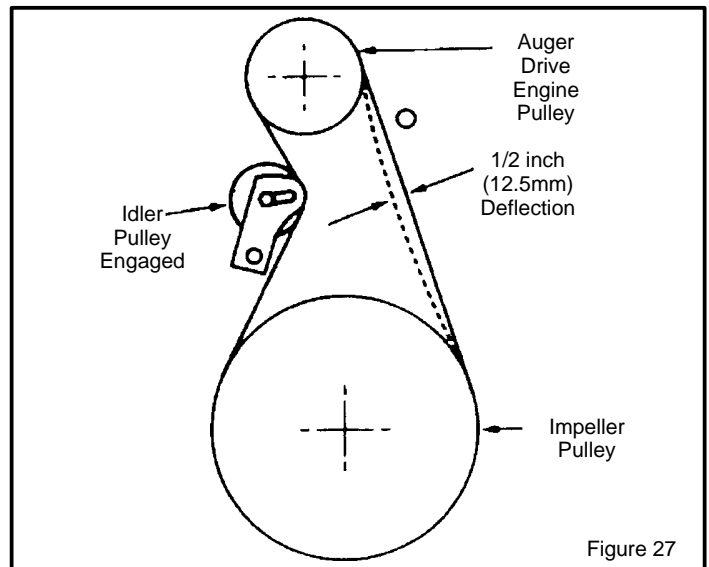

Figure 27

MAINTENANCE

HOW TO REPLACE THE BELTS

The drive belts are of special construction and must be replaced with original factory replacement belts available from your nearest authorized service center.

Some steps require the assistance of a second person.

How To Remove the Auger Drive Belt

If the auger drive belt is damaged, the snow thrower will not discharge snow. Replace the damaged belt as follows.

1. Disconnect the spark plug wire.
2. Loosen the **bolts** on each side of the **bottom panel** (see Figure 28).
3. Remove the **bottom panel**.
4. Remove **screw** from **belt cover**. Remove the **belt cover** (see Figure 26).
5. Loosen the **belt guide**. Pull the **belt guide** away from the **auger drive pulley** (see Figure 29).
6. Pull the **idler pulley** away from the **auger drive belt**.
7. Remove the old **auger drive belt** from the **auger drive pulley** and from the **engine pulley**. Replace the **auger drive belt** with an original factory replacement belt available from an authorized service center.
8. Install the new **auger drive belt** onto the **auger drive pulley** and onto **pulley**.
9. Adjust the **auger drive belt**. See "How To Adjust The Auger Drive Belt" in the Maintenance section.
10. Adjust the **belt guide**. See "How To Adjust The Belt Guide" in the Maintenance section.
11. Install the **belt cover**. Tighten **screw** (See Figure 26).
12. Check the adjustment of the cables. See "How To Check And Adjust The Cables" in the Maintenance section.
13. Install the **bottom panel** (see Figure 28).
14. Tighten the **bolts** on each side of the **bottom panel**.
15. Connect the spark plug wire.

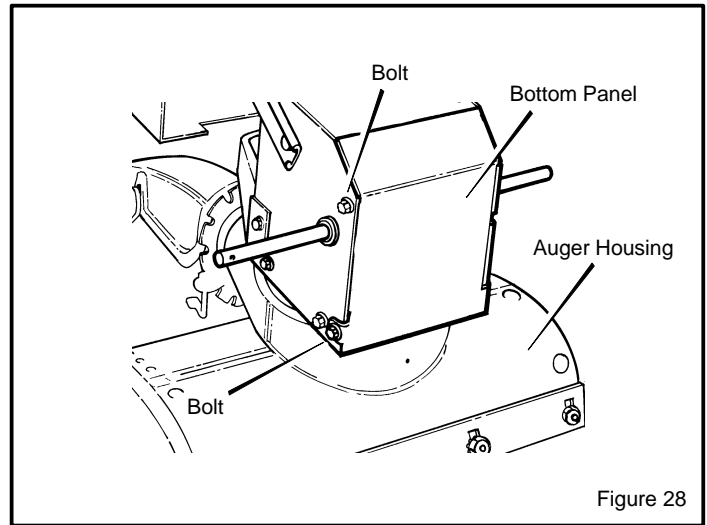

Figure 28

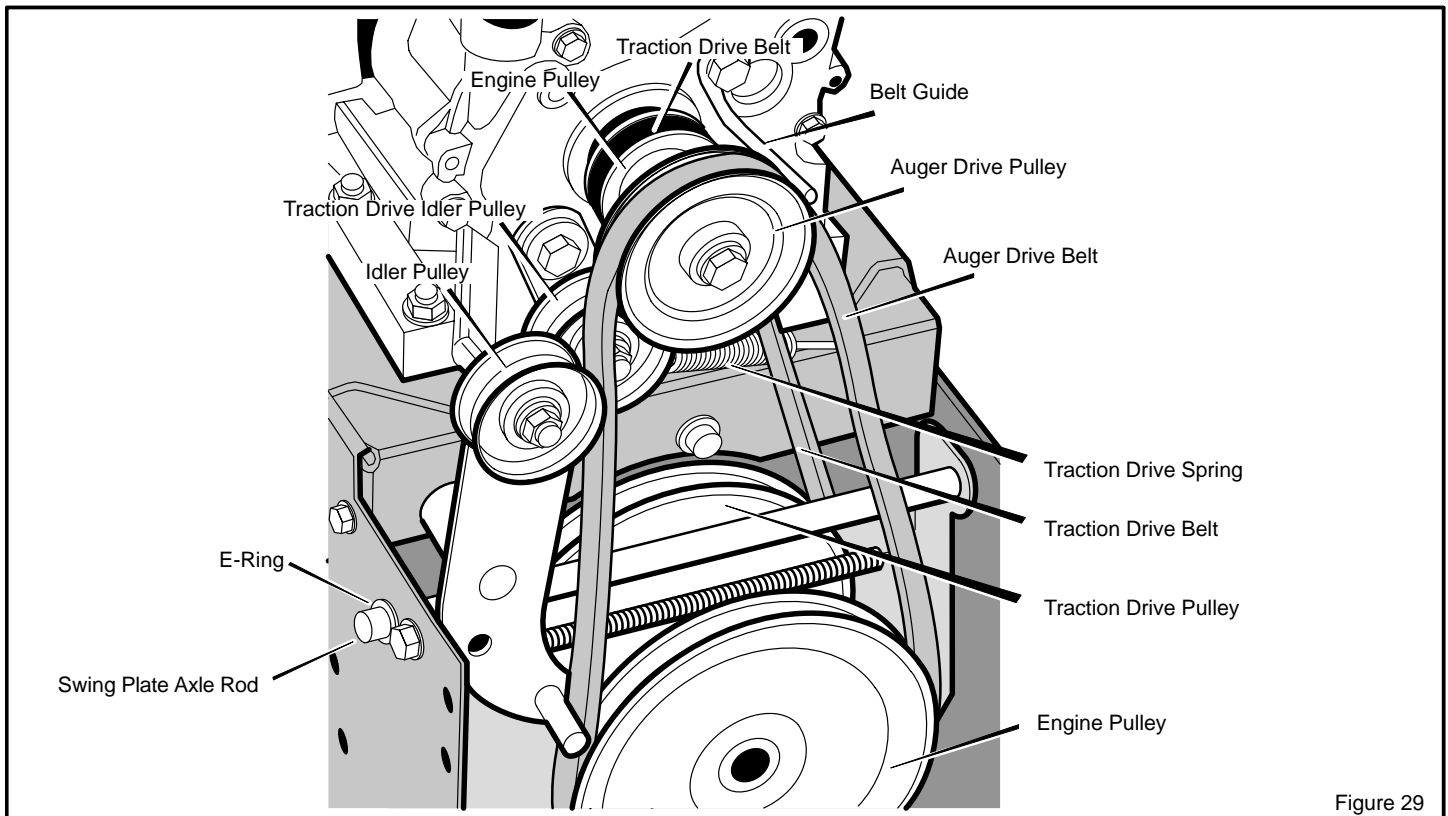

Figure 29

MAINTENANCE

How To Remove the Traction Drive Belt

If the snow thrower will not move forward, check the traction drive belt for wear or damage. If the traction drive belt is worn or damaged, replace the belt as follows.

1. Disconnect the spark plug wire.
2. Remove the auger drive belt. See "How To Remove The Auger Drive Belt" in the Maintenance section.
3. Remove the **e-ring** from one end of the **swing plate axle rod**. Remove the **swing plate axle rod** to allow the swing plate to pivot forward (see Figure 29).
4. Remove the **traction drive spring**.
5. Remove the old **traction drive belt** from the **traction drive pulley** and from the **engine pulley**. Replace the **traction drive belt** with an original factory replacement belt available from an authorized service center.
6. Install the new **traction drive belt** onto the **traction drive pulley** and onto **engine pulley**.
7. Make sure the **traction drive idler pulley** is properly aligned with the **traction drive belt**.
8. Attach the **traction drive spring**.
9. Install the **swing plate axle rod** and secure with the **e-ring** removed earlier.
10. The bottom of the **swing plate** must be positioned between the **alignment tabs**. Make sure the **swing plate** is properly secured (see Figure 30).
11. Install and adjust the **auger drive belt**. See "How To Remove The Auger Drive Belt" in the Maintenance section.
12. Adjust the **belt guide**. See "How To Adjust The Belt Guide" in the Maintenance section.
13. Install the **bottom panel** (see Figure 28).
14. Tighten the **bolts** on each side of the **bottom panel**.
15. Install the **belt cover**. Tighten **screw** (see Figure 26).
16. Check the adjustment of the cables. See "How To Check And Adjust The Cables" in the Maintenance section.
17. Connect the spark plug wire.

NOTE: If the drive will not engage after the traction drive belt has been replaced, then check to make sure that the swing plate is positioned between the alignment tabs.

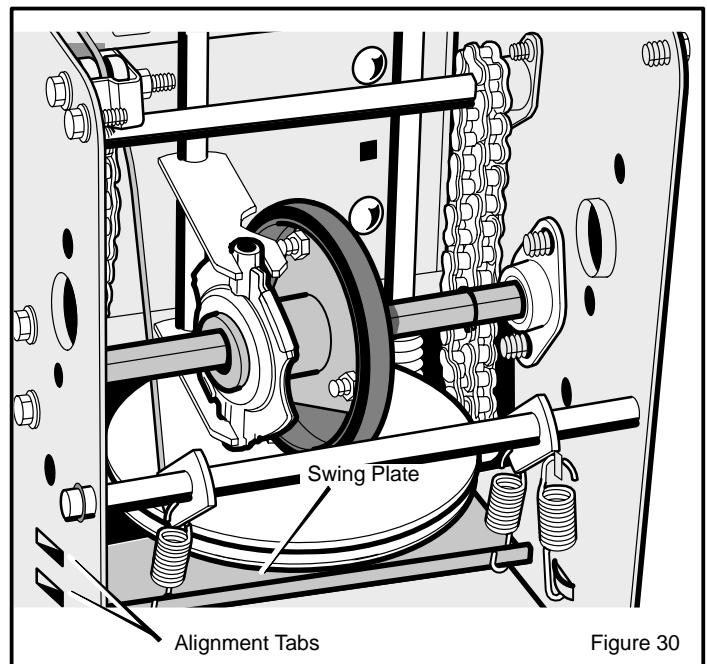

MAINTENANCE

BELT GUIDE ADJUSTMENT

1. Remove spark plug wire.
2. Have someone engage auger drive.
3. Measure the distance between the belt guide and belt. The distance should be 1/8 inch (3.175 mm) for guide. See Figure 31.
4. If adjustment is necessary, loosen belt guide mounting bolt. Move belt guide to the correct position. Tighten mounting bolt.
5. Reinstall belt cover.
6. Reconnect spark plug wire.

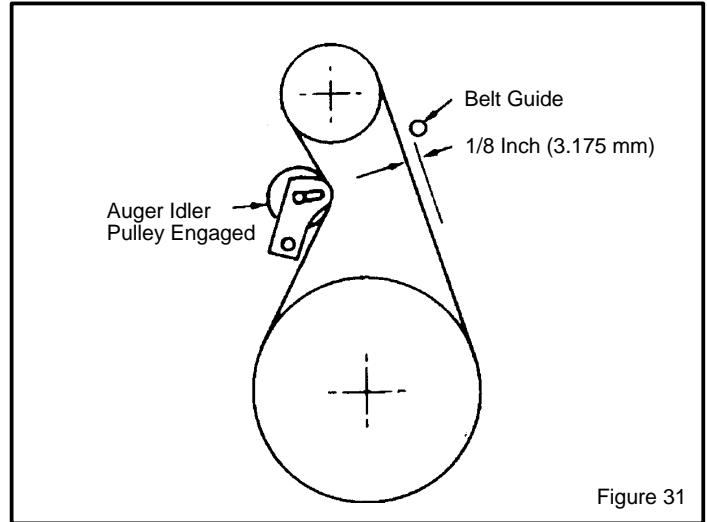

HOW TO CHECK AND ADJUST THE CABLES

The cables are adjusted at the factory and no adjustment should be necessary. If the cables have become stretched or are sagging adjustment will be necessary.

Whenever belts are adjusted or replaced, the cables will need to be adjusted.

To check for correct adjustment, unhook "Z" fitting at clutch lever (see Figure 32).

1. Move clutch lever to the full forward position. Holding cable tight, note position of fitting to hole in clutch lever.
2. The center of the "Z" fitting should be between the centre and top of the hole in the clutch lever. Adjust either the auger drive cable or the traction drive cable as follows.

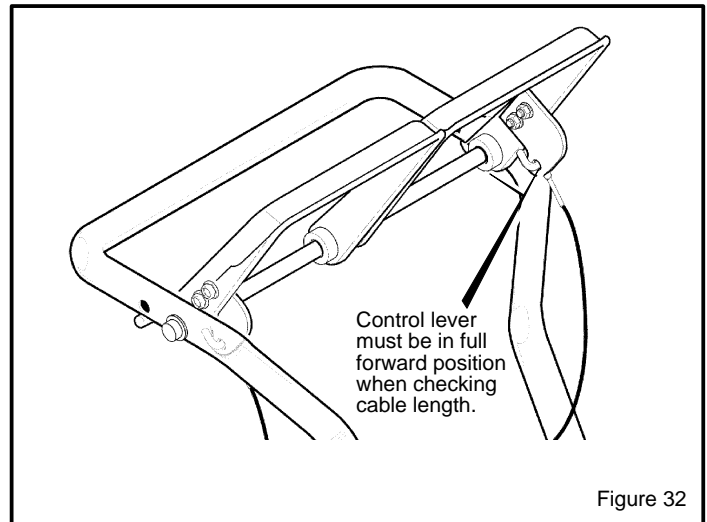

Auger Drive Cable Adjustment



WARNING: Drain the gasoline outdoors, away from fire or flame.

1. Remove the gas from the gas tank. Stand the snow thrower up on the front end of the auger housing.
2. Push cable through spring to expose the threaded portion of the cable (see Figure 33).
3. Hold square end of threaded portion with pliers and adjust locknut in or out until correct adjustment is reached. Pull cable back through spring and connect cable.

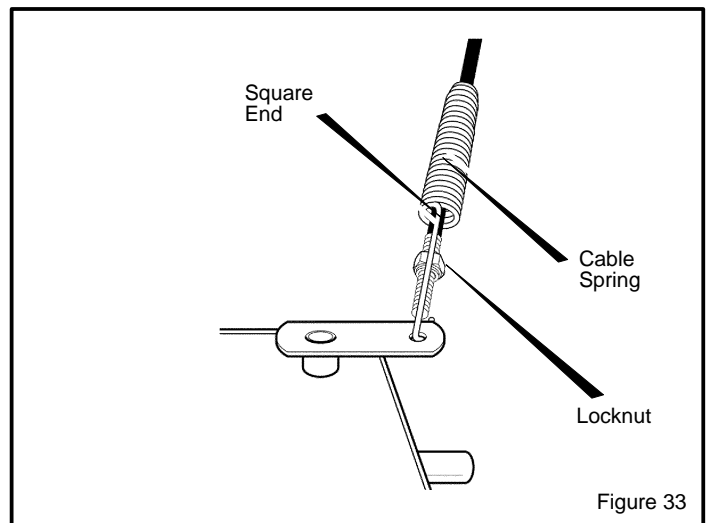

MAINTENANCE

Traction Drive Cable Adjustment



WARNING: Drain the gasoline outdoors, away from fire or flame.

1. Remove the gas from the gas tank. Stand the snow thrower up on the front end of the auger housing.
2. Loosen the **bolts** on each side of the **bottom panel** (see Figure 34).
3. Remove the **bottom panel**.
4. Disconnect the **“Z” fitting** from the **drive lever** (see Figure 32).
5. Slide the **cable boot** off the **cable adjustment bracket** (see Figure 35).
6. Push the bottom of the **traction drive cable** through the **cable adjustment bracket** until the **“Z” hook** can be removed.
7. Remove the **“Z” hook** from the **cable adjustment bracket**. Move the **“Z” hook** down to the next adjustment hole.
8. Pull the **traction drive cable** up through the **cable adjustment bracket**.
9. Put the **cable boot** over the **cable adjustment bracket**.
10. Install the **“Z” hook** to the **traction drive lever** (see Figure 32).
11. To check the adjustment, depress the drive lever and check the length of the **drive spring** (see Figure 36). In correct adjustment, the length of the **drive spring** is
minimum 3 inches (76 mm.)
maximum 3-3/8 inches (85 mm.).
12. Install the **bottom panel** (see Figure 34).
13. Tighten the **bolts** on each side of the **bottom panel**.

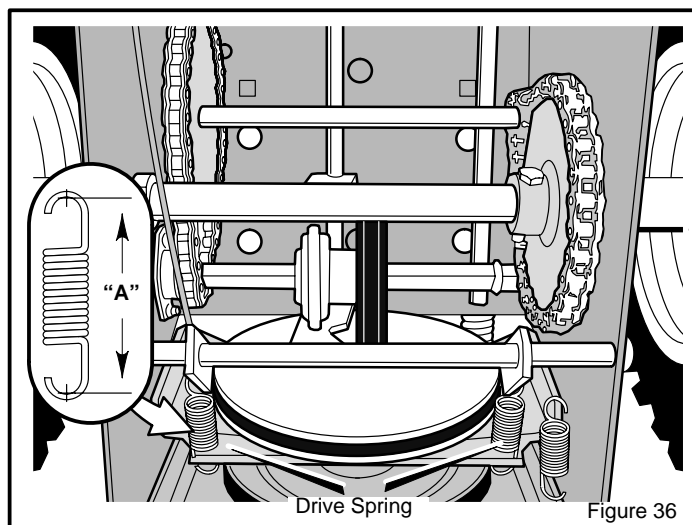
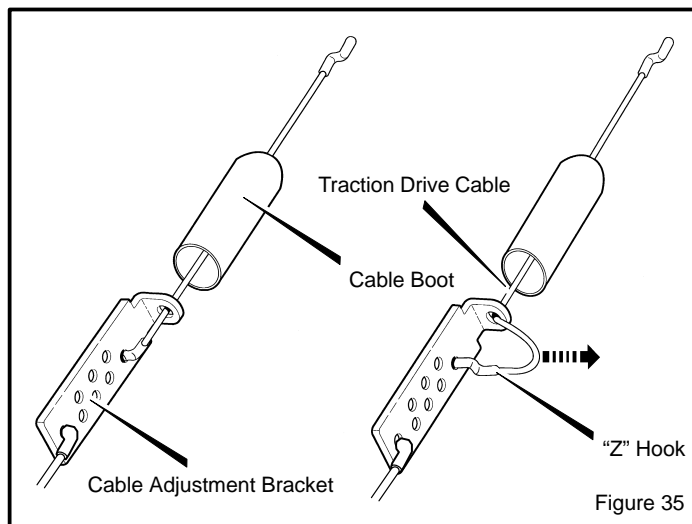
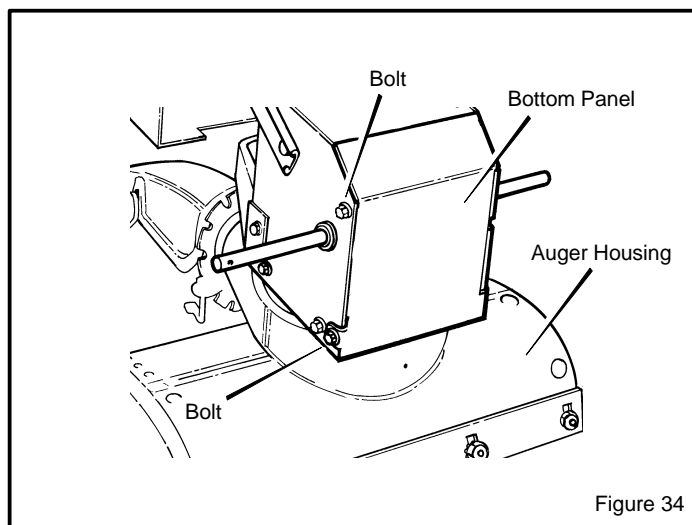

MAINTENANCE

HOW TO ADJUST OR REPLACE THE FRICTION WHEEL

How To Check The Friction Wheel

If the snow thrower will not move forward, check the traction drive belt, the traction drive cable or the friction wheel. If the friction wheel is worn or damaged, it must be replaced. See "How To Replace the Friction Wheel" in this section. If the friction wheel is not worn or damaged, check as follows.

1. Remove the gas from the gas tank. Stand the snow thrower up on the front end of the **auger housing** (see Figure 37).



WARNING: Drain the gasoline outdoors, away from fire or flame.

2. Disconnect the spark plug wire.
3. Loosen the **bolts** on each side of the **bottom panel** (see Figure 37).
4. Remove the **bottom panel**.
5. Position the **shift speed lever** in the lowest forward speed.
6. Note the position of the **friction wheel** (see Figure 38). The correct distance "A" from the right side of the **friction wheel** to the outside of the motorbox is as follows:

Tire Size	Distance "A"
12 and 13 inch	4-1/8" (10.5 cm.)
16 inch	4-5/16" (10.95 cm.)

If the **friction wheel** is not in the correct position, adjust as follows.

How To Adjust The Friction Wheel

1. Position the **shift speed lever** in the lowest forward speed.
2. Loosen the **bolts** on the **speed control rod** (see Figure 39).
3. Move the **friction wheel** to the correct position (see Figure 38).
4. Tighten the **bolts** on the **speed control rod** (see Figure 39).

5. Install the **bottom panel** (see Figure 37).

6. Tighten the **bolts** on each side of the **bottom panel**.

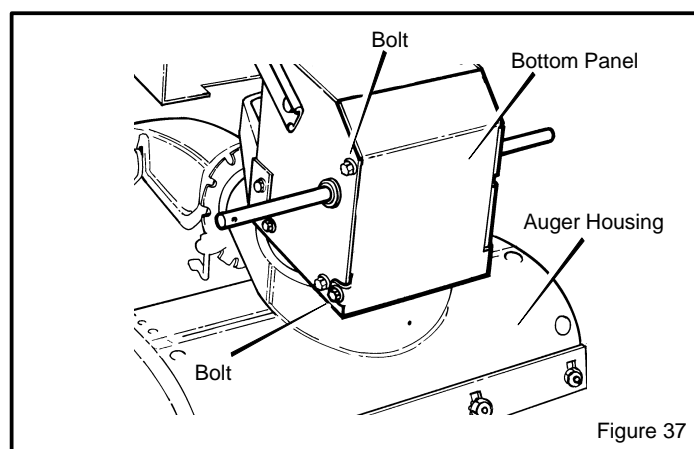

Figure 37

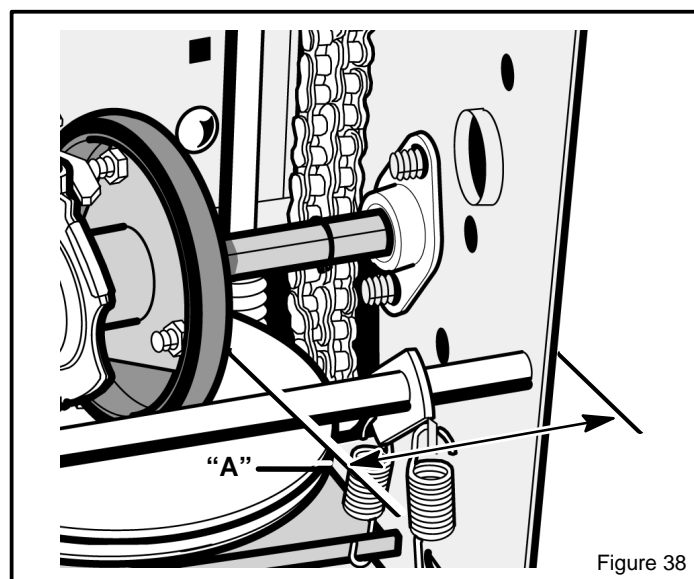

Figure 38

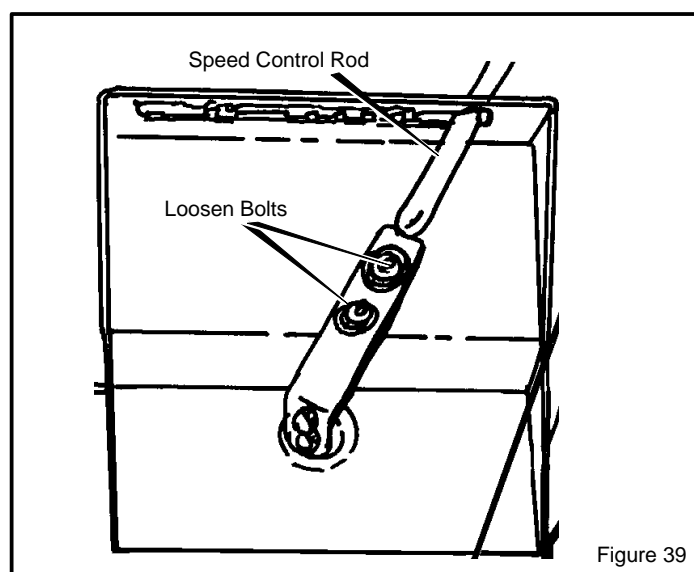

Figure 39

MAINTENANCE

How To Replace The Friction Wheel

If the friction wheel is worn or damaged, the snow thrower will not move forward. The friction wheel must be replaced as follows.

1. Remove the gas from the gas tank. Stand the snow thrower up on the front end of the **auger housing (4)**. (see Figure 37).



WARNING: Drain the gasoline outdoors, away from fire or flame.

2. Disconnect the spark plug wire.
3. Remove the fasteners that secure the left **wheel**. Remove the **left wheel** from the **axle** (see Figure 40)
4. Loosen the **bolts** on each side of the **bottom panel**.
5. Remove the **bottom panel**.

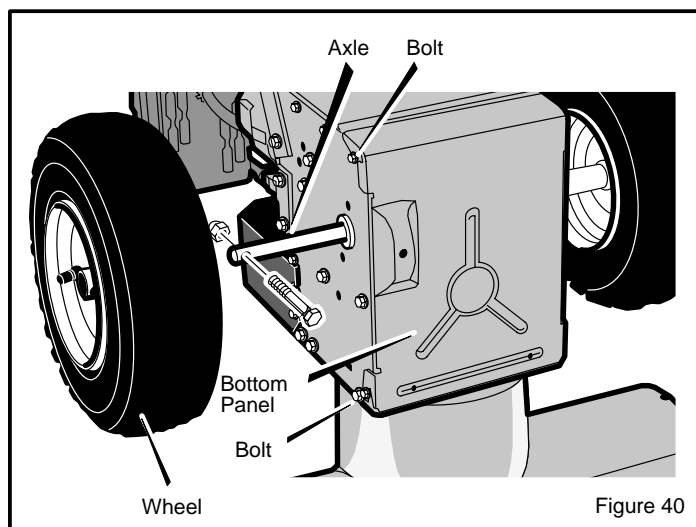

6. Remove the fasteners that secure the **drive sprocket** to the **axle** (see Figure 41).
7. Remove the right wheel, **axle**, and **drive sprocket**.

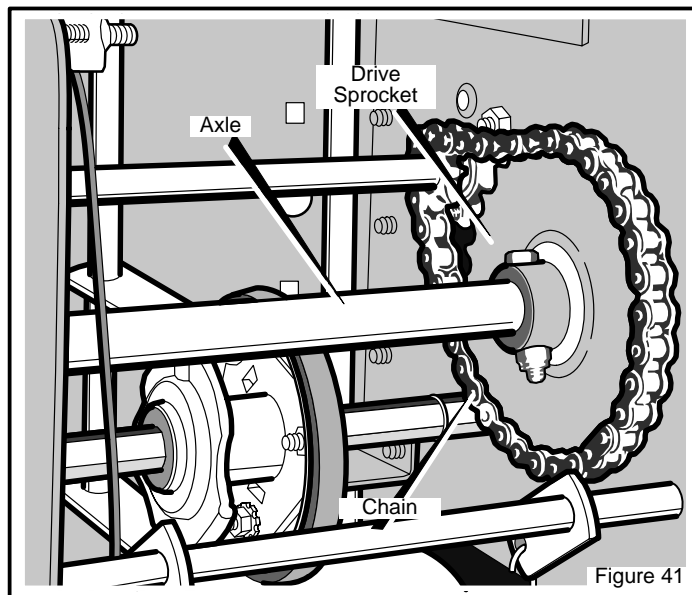

8. Remove the four **bolts** that hold the **bearings** on each side of the **hex shaft** (see Figure 42).
9. Remove the **hex shaft** and **bearings**.

NOTE: Take special note of the position of the washers on the hex shaft.

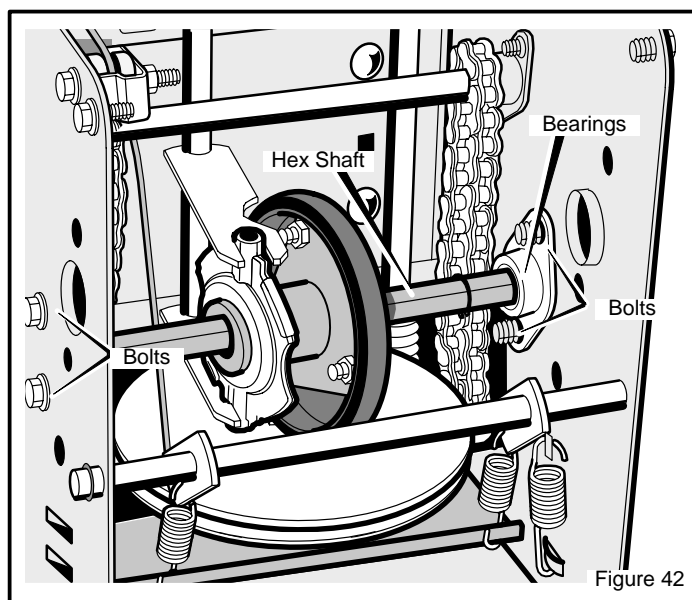

MAINTENANCE

10. Remove the three **fasteners** that hold the **friction wheel** to the **hub** (see Figure 43).
11. Remove the **friction wheel** from the **hub**. Slip the **friction wheel** off the **hex shaft**.
12. Assemble the new **friction wheel** onto **hub** with the fasteners removed earlier.

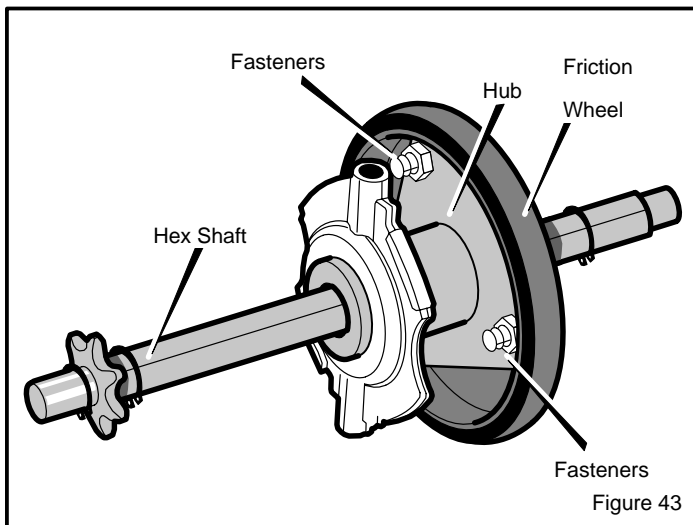

13. Install the **hex shaft** and **bearings** with the four bolts removed earlier (see Figure 44).

Make sure the washers are properly installed in the original position. Also, make sure the two washers are properly aligned with the actuator arms.

14. Make sure the **hex shaft** turns freely.

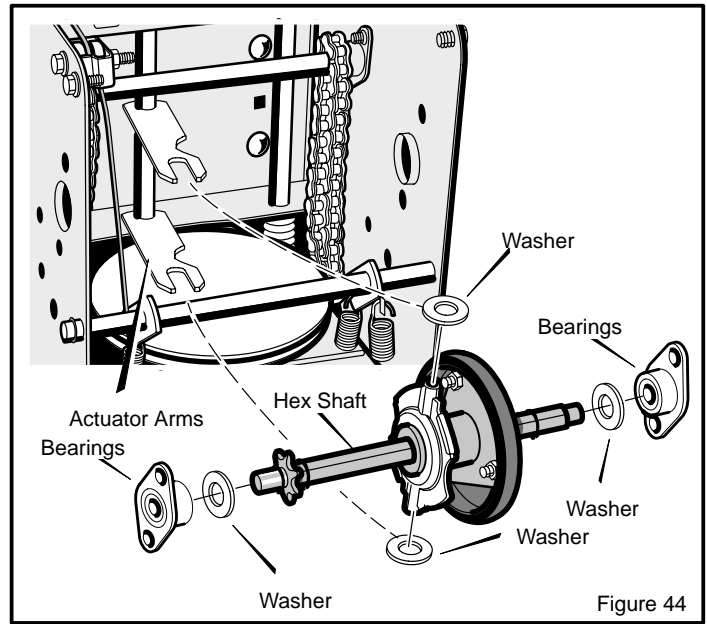

15. Install the right wheel, **axle**, and **drive sprocket** with the fasteners removed earlier. Install the **chain** onto the **drive sprocket** (see Figure 41).
16. Check the adjustment of the friction wheel. See "How To Adjust The Friction Wheel" in this section.
17. Make sure the friction wheel and the disc drive plate are free from grease or oil.
18. Install the **bottom panel** (see Figure 40).
19. Tighten the **bolts** on each side of the **bottom panel**.
20. Install the **left wheel** to the **axle** with the fasteners removed earlier.
21. Connect the spark plug wire.

MAINTENANCE

AUGER SHEAR BOLT REPLACEMENT

The augers are secured to the auger shaft with special bolts that are designed to break if an object becomes lodged in the auger housing. Use of a harder bolt will reduce the protection provided by the shear bolt. To replace a broken shear bolt, proceed as follows:



WARNING: To insure safety and performance levels, only original replacement shear bolts should be used.

1. Move throttle to STOP, disengage all controls, disconnect the spark plug lead wire, and insure all moving parts have stopped.
2. Align the hole in the auger with the hole in the auger shaft. Install new shear bolt, spacer and locknut found in the toolbox located on the belt cover (See Figure 45).

NOTE: The spacer fits into the larger hole in the auger tube.

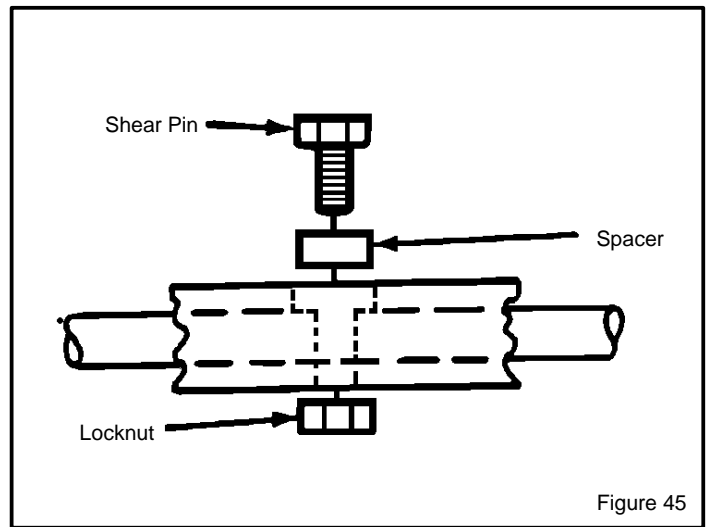

TO ADJUST OR REPLACE THE SPARK PLUG

Check the **spark plug** every twenty-five (25) hours. Replace the **spark plug** if the electrodes are pitted or burned or if the porcelain is cracked.

1. Clean spark plug and reset gap periodically.
2. Clean area around spark plug base before removal, to prevent dirt from entering engine.
3. Replace spark plug if electrodes are pitted or burned or if porcelain is cracked.
4. Clean spark plug by carefully scraping electrodes (do not sandblast or use wire brush).
5. Be sure spark plug is clean and free of foreign material. Check electrodes gap with a wire feeler gauge and reset gap to 0.030" (0.76 mm) if necessary. If a new spark plug is needed, refer to Engine Repair Parts section of this manual for proper replacement spark plug.
6. Before installing spark plug, coat threads lightly with graphite grease to insure easy removal.

7. Tighten plug firmly into engine. If torque wrench is available, torque plug to 18-23 ft-lbs.

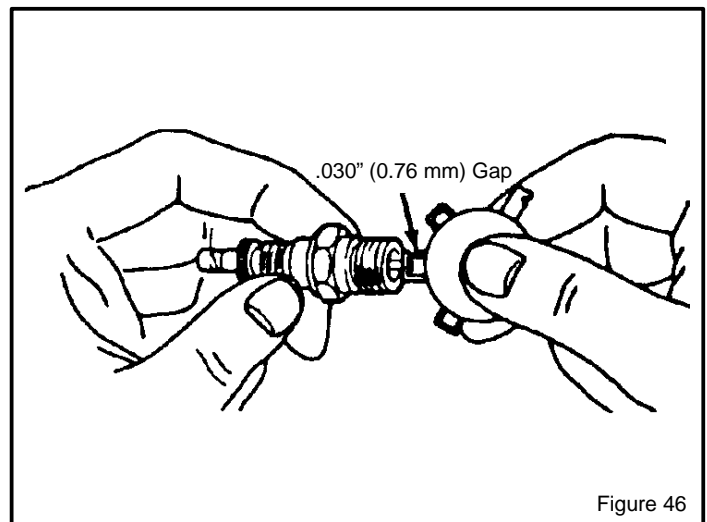

STORAGE

OFF SEASON STORAGE



WARNING: Never store the engine, with fuel in the tank, indoors or in a poor ventilated enclosure where fuel fumes could reach an open flame, spark or pilot light as on a furnace, water heater, clothes dryer, etc.

Handle gasoline carefully. It is highly flammable and careless use could result in serious fire damage to your person and/or property.

Drain fuel into approved containers outdoors, away from open flame.

If the snowthrower is to be stored for thirty (30) days or more at the end of the snow season, the following steps are recommended to prepare your snowthrower for storage.

NOTE: Gasoline must be removed or treated to prevent gum deposits from forming in the tank, filter, hose, and carburetor during storage.

1. To remove gasoline, run engine until tank is empty and engine stops.

If you do not want to remove the gasoline, add fuel stabilizer to any gasoline left in the tank to minimize gum deposits and acids. If the tank is almost empty, mix stabilizer with fresh gasoline in a separate container and add some to the tank. ALWAYS FOLLOW INSTRUCTIONS ON STABILIZER CONTAINER. THEN RUN ENGINE AT LEAST 10 MINUTES AFTER STABILIZER IS ADDED TO ALLOW MIXTURE TO REACH CARBURETOR. STORE SNOWTHROWER IN SAFE PLACE.

2. You can help keep your engine (4-cycles only) in good operating condition by changing oil before storage.
3. Lubricating the piston/cylinder area. This can be done by first removing the spark plug and squirting clean engine oil into the spark plug hole. Then cover the spark plug hole with a rag to absorb oil spray. Next, rotate the engine by pulling the starter two or three times. Finally, reinstall spark plug and attach spark plug wire.

4. Thoroughly clean the snowthrower.
5. Lubricate all lubrication points (see "Lubrication" in the Maintenance section).
6. Insure that all nuts, bolts, and screws are securely fastened. Inspect all visible moving parts for damage, breakage, and wear. Replace if necessary.
7. Touch up all rusted or chipped paint surfaces; sand lightly before painting.
8. Cover the bare metal parts of the snowthrower housing auger, and the impeller with rust preventative.
9. If possible, store your snowthrower indoors and cover it to give protection from dust and dirt.
10. On models with folding handles, loosen the knobs that secure the upper handle. Rotate the upper handle back.
11. If the machine must be stored outdoors, block up the snowthrower and insure the entire machine is off the ground. Cover the snowthrower with a heavy tarpaulin.

REMOVING THE SNOWTHROWER FROM STORAGE

When removing the snowthrower from storage, follow the steps below.

1. Put the upper handle in the operating position, tighten the knobs that secure the upper handle.
2. Fill the fuel tank with a fresh fuel.
3. Check the spark plug. Make sure the gap is correct. If the spark plug is worn or damaged, replace before using.
4. Make sure all fasteners are tight.
5. Make sure all guards, shields, and covers are in place.
6. Make sure all adjustments are correct.

TROUBLE SHOOTING CHART

PROBLEM	LOOK FOR	REMEDY
Difficult starting	Defective spark plug.	Replace defective spark plug.
Engine runs erratically	Blocked fuel line.	Clean fuel line.
	Empty gas tank.	Check fuel supply,
	Stale gasoline.	Add fresh gasoline with fuel stabilizer.
	Water or dirt in fuel system.	Remove carburetor bowl to drain fuel tank. Refill with fresh fuel. CAUTION: Do not remove carburetor bowl when the engine is hot.
Engine stalls	Unit running on CHOKE.	Set choke lever to RUN position.
Loss of power	Gas cap vent hole is plugged.	Remove ice and snow from cap. Be sure vent hole is clear.
Excessive vibration	Loose parts or damaged impeller.	Stop engine immediately and remove spark plug wire. Tighten all bolts and make all necessary repairs. If vibration continues, have the unit serviced by a competent repairman.
Unit fails to propel itself	Drive belt loose or damaged.	Replace drive belt. Refer to Drive Belt Replacement in the Maintenance section of this manual.
	Incorrect adjustment of traction drive cable.	Adjust traction drive cable. Refer to Cable Adjustment in the Maintenance section of this manual.
	Worn or damaged friction disc.	Replace friction disc. Refer to Friction Wheel Replacement in the Maintenance section of this manual.
Unit fails to discharge snow	Auger drive belt loose or damaged.	Replace or adjust auger drive belt. Refer to Drive Belt Replacement and Drive Belt Adjustment in the Maintenance section of this manual.
	Auger control cable not adjusted correctly.	Adjust auger control cable. Refer to Cable Adjustment in the Maintenance section of this manual.
	Broken shear bolt.	Replace shear bolt. Refer to Auger Shear Bolt Replacement in the Maintenance section of this manual.
	Discharge chute clogged.	Stop engine immediately and disconnect spark plug wire. Refer to the first Warning in Snowthrower Operation in the Operation section of this manual. Clean discharge chute and inside of auger housing.
	Foreign object lodged in auger.	Stop engine immediately and disconnect spark plug wire. Refer to the third Warning in Snowthrower Operation in the Operation section of this manual. Remove object from auger.

Identifying Your Snowthrower

Your new Snow blower has two (2) identifying numbers: (1) unit model number: (2) unit serial number. The two preceding numbers are required to insure that the proper replacement parts are obtained when required. If you have any questions concerning parts, service, or technical data, contact your nearest John Deere/Frontier dealer.

For complete warranty information refer to the warranty in the Owner's Information section of this manual.

REPLACEMENT PARTS

WE RECOMMEND JOHN DEERE/FRONTIER quality parts and lubricants available at your John Deere/Frontier dealer.

PART NUMBERS MAY CHANGE. When you order replacement parts, use the part numbers listed below and on the following pages. If a part number changes, your John Deere/Frontier dealer will have the latest part number.

WHEN YOU ORDER PARTS, your John Deere/Frontier dealer must have your snowthrower model and serial number and your engine model number. This is the model and serial number that you recorded in the "Owner's Information" section of this Owner's Manual.

QUICK REFERENCE PART NUMBERS

The following is a list of replacement parts that you may need for routine service and maintenance. If you do not see the replacement part you need in the following chart, then check the full list of replacement part illustrations following this page.

ITEM	PART NUMBER *
Belt, Drive	MT579932
Belt, Auger	MT585416
Scraper Blade	MT581397E701
Spark Plug	Champion RC12YC

* **Part Numbers are subject to change without notice.**

FRONTIER MODEL ST0524

FACTORY MODEL 624504x16A ENGINE

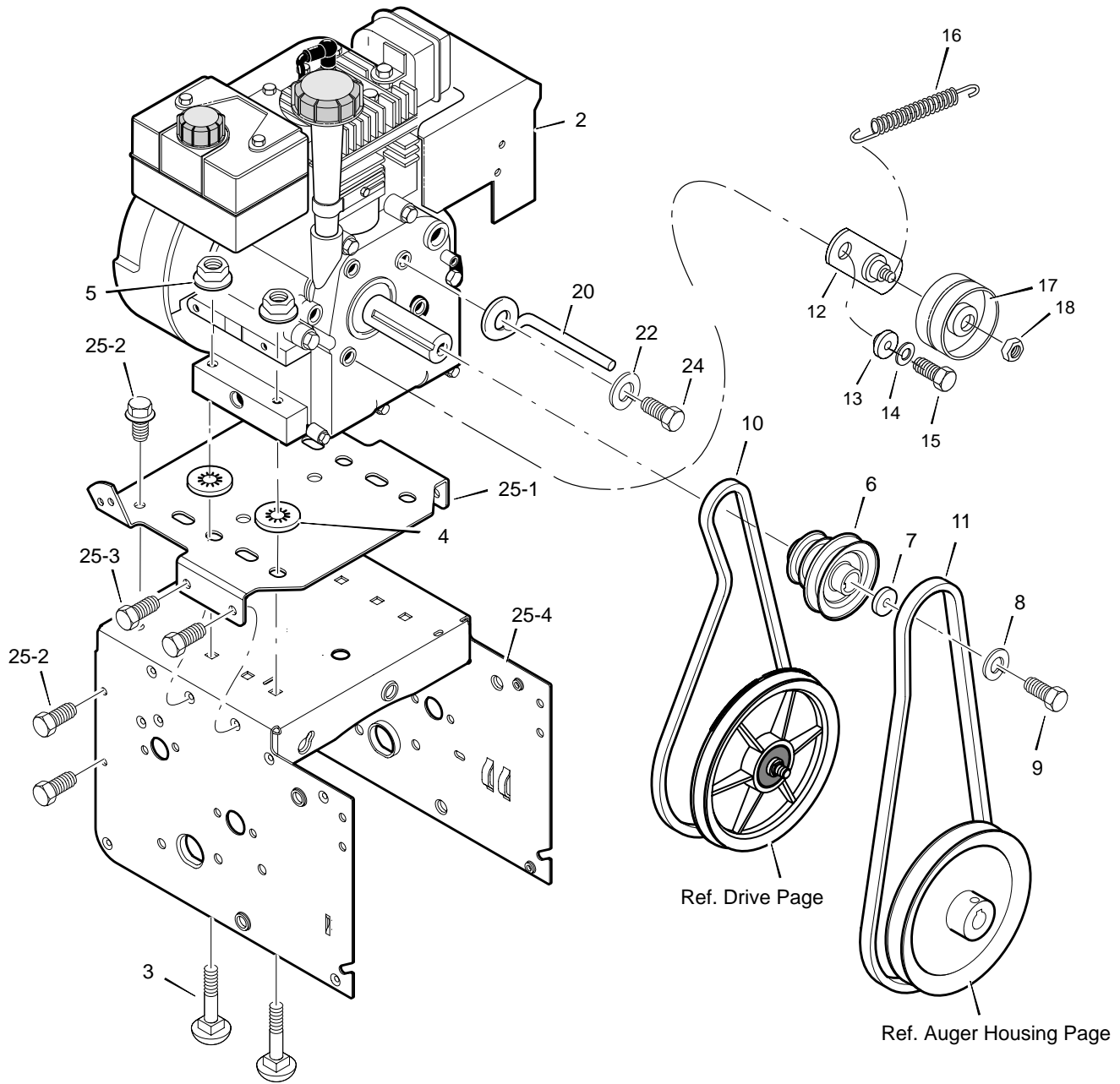

Key No.	Part No.	Description
2	-----	ENGINE
3	MT002x97	BOLT, CARRIAGE 5/16-18
4	MT028x76	RETAINER, PUSH
5	MT710026	NUT 5/16-18
6	MT1501109	PULLEY, ENGINE
7	MT710247	WASHER
8	MT71063	WASHER .38ID
9	MT71015	SCREW, 3/8-24X1.00
10	MT579932	BELT, DRIVE V 3L
11	MT585416	BELT, AUGER V 4L
12	MT1501112 YZ	BRACKET ASSEMBLY, IDLER
13	MT1501065	BUSHING, IDLER BRACKET
14	MT71060	WASHER, SPLIT

Key No.	Part No.	Description
15	MT710097	SCREW 5/16-24 X 0.75
16	MT53704	SPRING, IDLER TRACTION DRIVE
17	MT50793	PULLEY, IDLER
18	MT590	NUT, JAM 3/8-16
20	MT1501201	GUIDE, BELT
22	MT71060	WASHER .31X.58X.08
24	MT710097	SCREW, 5/16-24X .75
25	-----	FRAME, MOTORBOX (5-11HP)
25-1	MT1501062E511	PLATE, ENGINE MOUNT
25-2	MT310169	SCREW, TAP 1/4-20 X .63
25-3	MT25x020	SCREW, TAP 5/16-18 X .50
25-4	MT1501049E511	FRAME, MOTOR BOX
--	MTF-031072L	OWNER'S MANUAL

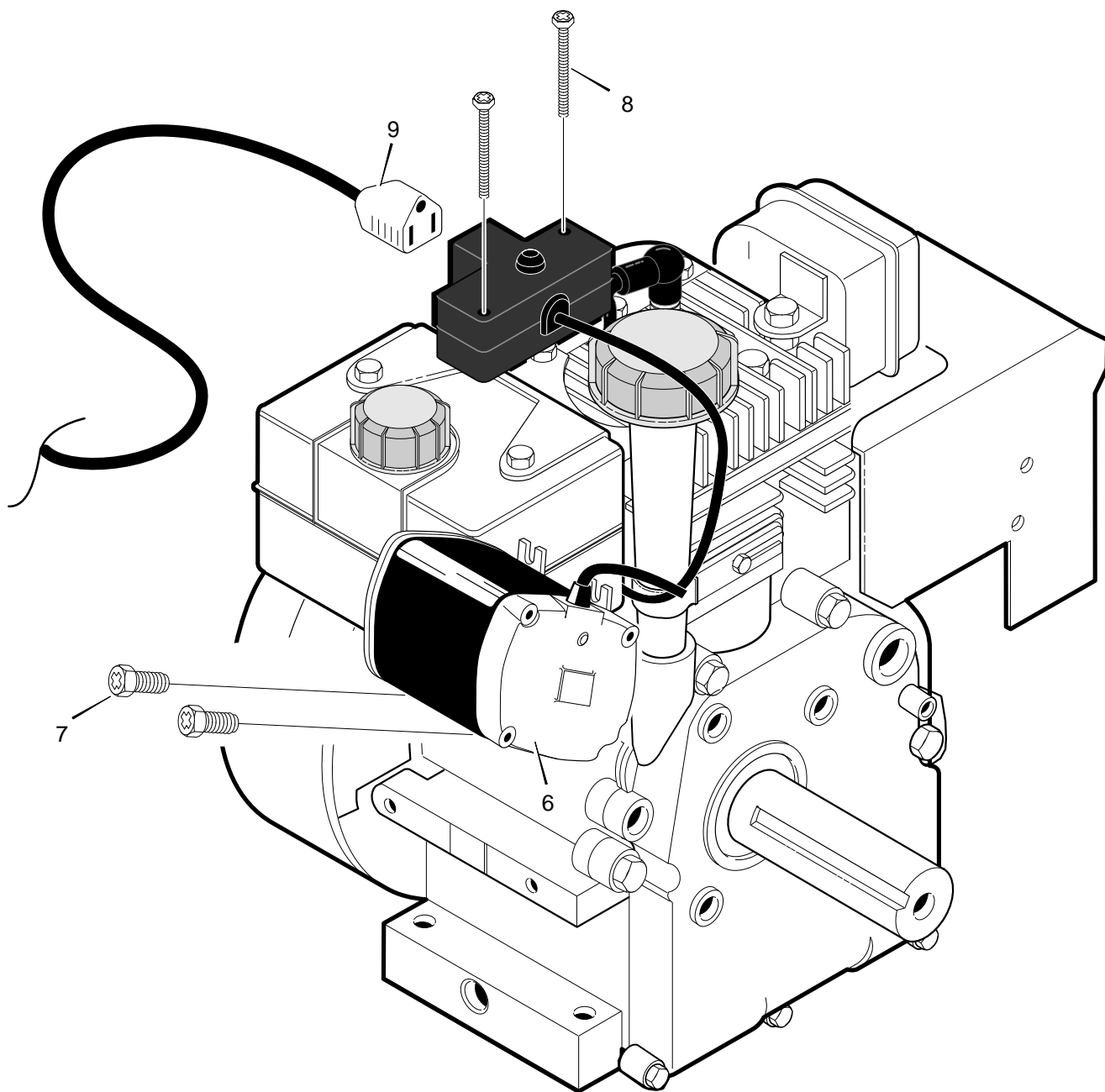

Key No.	Part No.	Description
6	MT330783	MOTOR, STARTER
7	MT762226	SCREW
8	MT6217	SCREW
9	MT6219	CORD, STARTER

FRONTIER MODEL ST0524

FACTORY MODEL 624504x16A FRAME

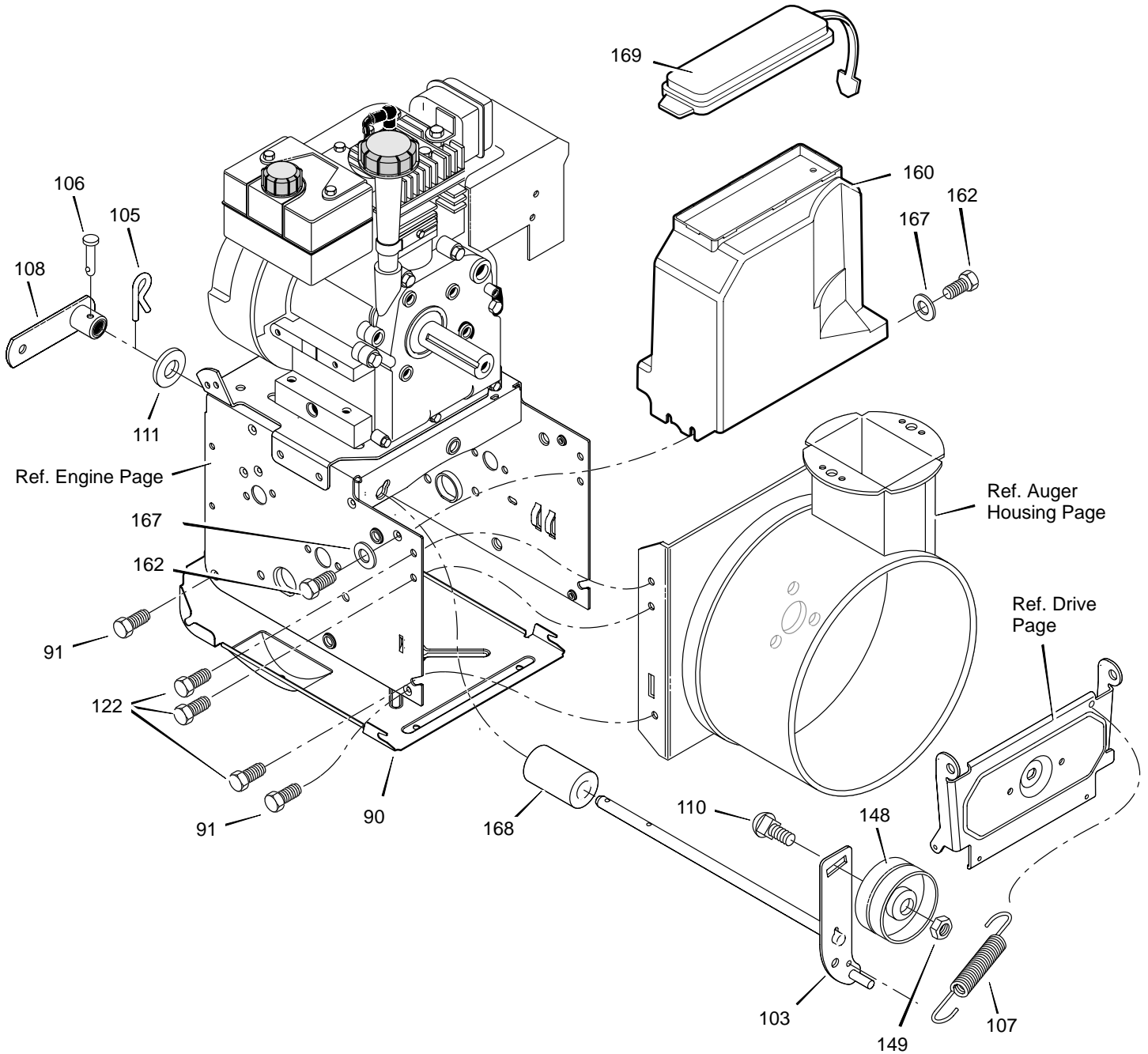

FRONTIER MODEL ST0524

FACTORY MODEL 624504x16A FRAME

Key No.	Part No.	Description
90	MT1501055E701	COVER, BOTTOM
91	MT310169	SCREW, 1/4-20X .63
103	MT1501111 YZ	IDLER ASSEMBLY, AUGER
105	MT711682	PIN, HAIR .38DIA X 1.64LG
106	MT761761	PIN, CLEVIS 3/16" DIA
107	MT165x160	SPRING, TENSION
108	MT761675 YZ	ASSY., SPRING ATTACH
110	MT585781	BOLT, 3/8-16 X 1.25 CARR.
111	MT711617	WASHER, FLAT
122	MT780055	SCREW, TAP 5/16-18 X .50
148	MT50793	PULLEY, IDLER
149	MT590	NUT, JAM 3/8-16
160	MT1501052	COVER, BELT
162	MT26X306	SCREW, TAP
167	MT71067	WASHER, FLAT
168	MT1501200	SPACER, AUGER BRACKET
169	MT760539	LID, TOOL BOX

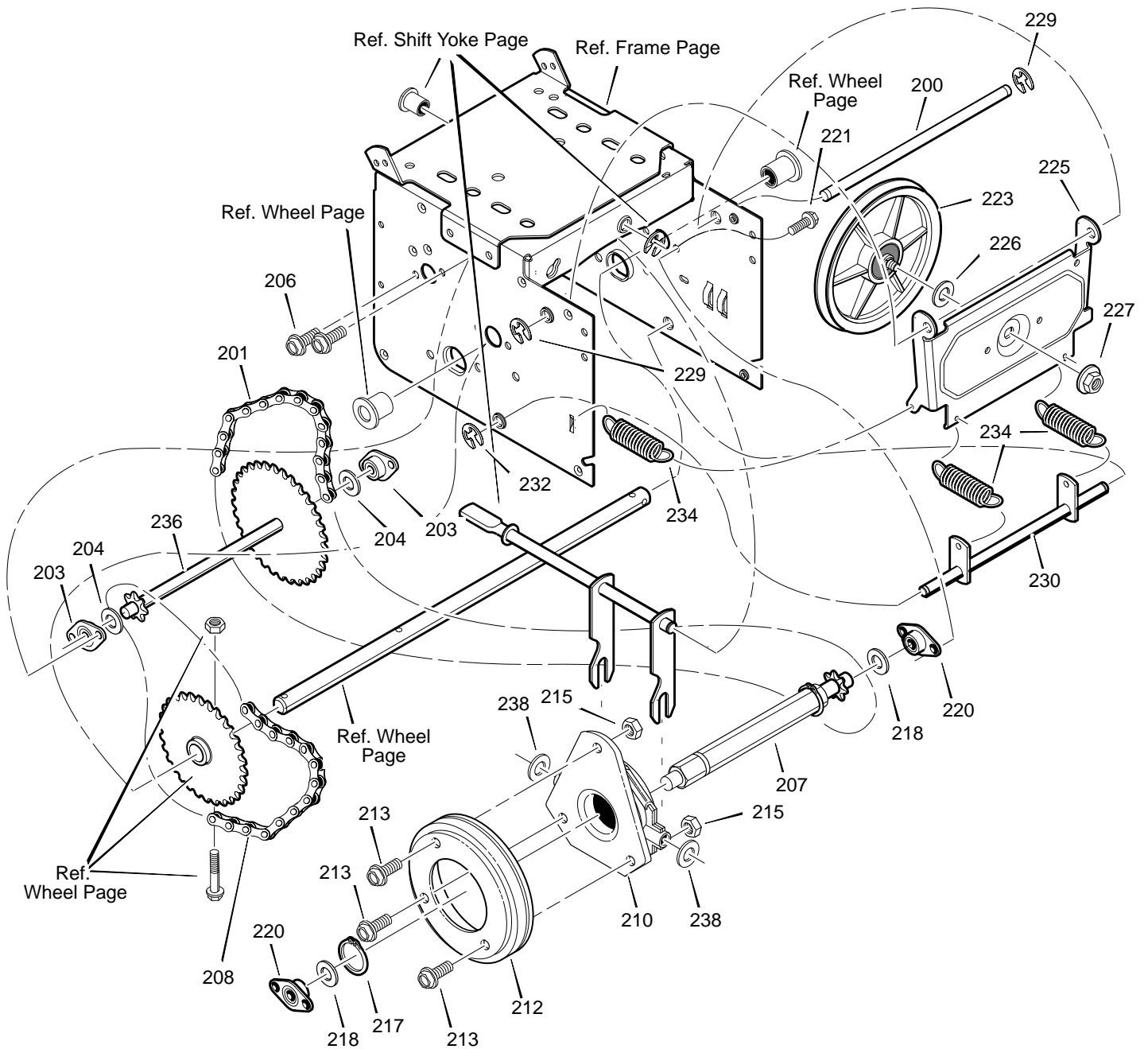

FRONTIER MODEL ST0524

FACTORY MODEL 624504x16A DRIVE

Key No.	Part No.	Description
200	MT1501092 YZ	LF AXLE, SWING PLATE YZ
201	MT579851	CHAIN, ROLLER #420x19.00
203	MT334163	BEARING AND RETAINER, ASSY
204	MT579858	WASHER
206	MT780055	SCREW, TAP 5/16-18x0.5
207	MT1501100	ASSY, HEX SHAFT
208	MT579868	CHAIN, ROLLER #420x18.00 LG
210	MT337029	BEARING, TRUNION CLUTCH R
212	MT1501435	WHEEL, FRICTION DISC
213	MT001x38	BOLT
215	MT303008	NUT, KEPS HEX 1/4-20
217	MT579859	RING, RETEXT
218	MT579858	WASHER
220	MT334163	BEARING AND RETAINER, ASSY
221	MT780055	SCREW, TAP 5/16-18 x .5
223	MT1501115	FRICTION PULLY
225	MT1501057 YZ	LF PLATE, SWINGING YZ
226	MT1501158	SPACER, FRICTION PULLEY
227	MT15X114	NUT, FLANGE LOCK 3/8-24
229	MT11X30	RETAINER, RING
230	MT1501107 YZ	LF ASSY, SPRING LINK YZ
232	MT11X30	RETAINER, RING
234	MT165X112	SPRING, EXTENSION
236	MT1501090	SPROCKET 33/7
238	MT71074	WASHER, FLAT

FRONTIER MODEL ST0524

FACTORY MODEL 624504x16A AUGER HOUSING

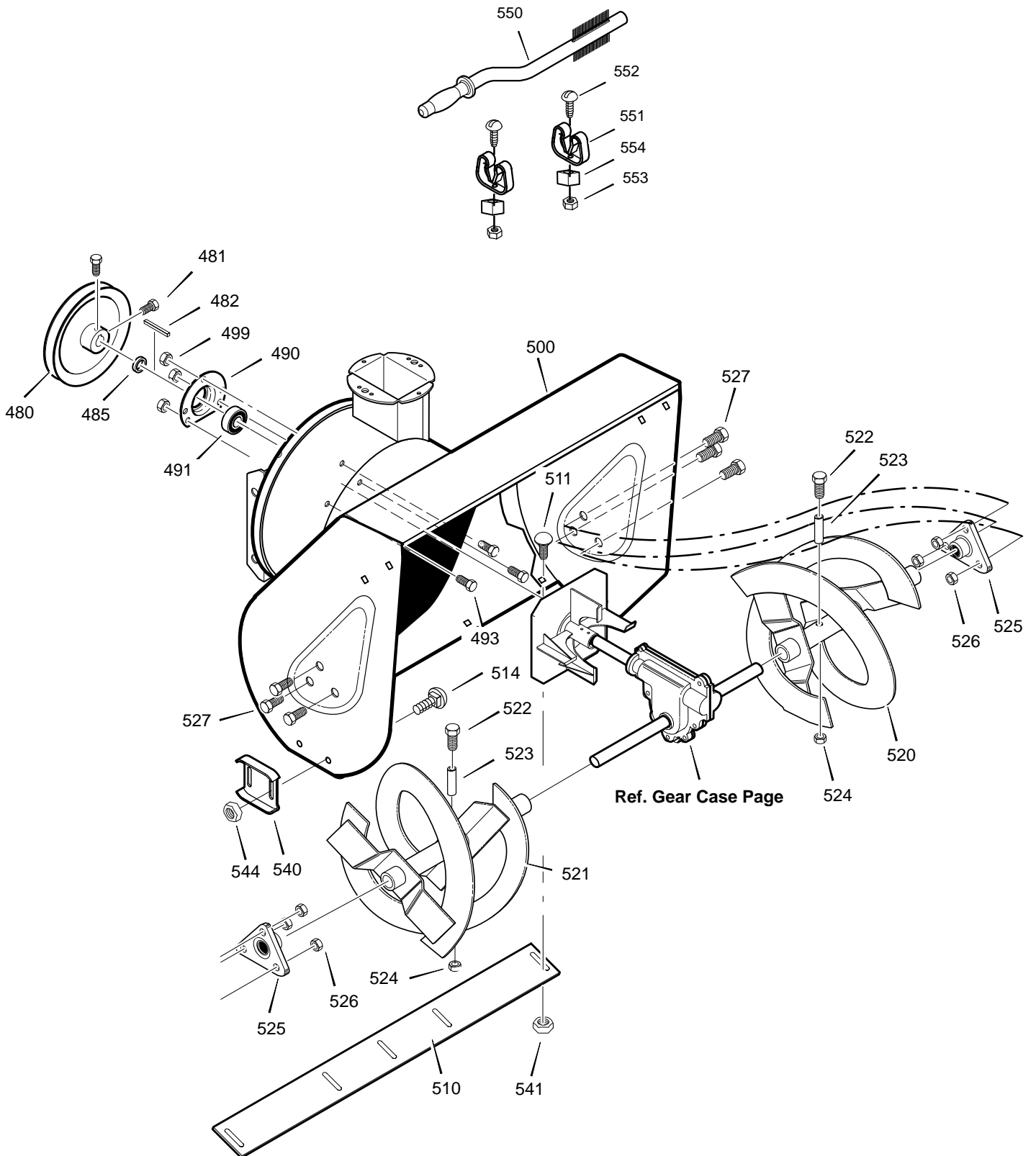

FRONTIER MODEL ST0524

FACTORY MODEL 624504x16A AUGER HOUSING

Key No.	Part No.	Description
480	MT762146	PULLEY, 4L 6.12X .67
481	MT577400	SCREW, 5/16-18X.63
482	MT2001022	KEY, SQUARE 3/16 X 3/4
485	MT1501158	SPACER, FRICTION PULLEY
490	MT582957 YZ	RETAINER, BALL BRNG
491	MT43846	BEARING, BALL
493	MT001X92	BOLT, HEX 5/16-18X .50
499	MT710026	NUT, 5/16-18 HEXWDFLLK
500	MT1501585E511	HOUSING, ASSY
510	MT581397E701	BLADE, SCRAPER
511	MT340714	BOLT, 1/4-20X.75
514	MT780285	NUT, 1/4-20
520	MT1501209E701	AUGER, ASSY, LH
521	MT1501210E701	AUGER, ASSY, RH
522	MT9524	SCREW, 1/4-20X1.75
523	MT3943	SPACER, SLEEVE
524	MT73826	NUT, 1/4-20
525	MT9517	BEARING, FLANGE
526	MT711862	NUT, 5/16-18
527	MT9357	SCREW, 5/16-18X .75
540	MT1501609E701	SKID, HEIGHT ADJUST
541	MT340720	BOLT, 5/16-18 X .75
544	MT710026	NUT, 5/16-18
550	MT1501576	BRUSH, CLEANOUT
551	MT1501672	CLIP, RETAINER
552	MT06x115	SCREW
553	MT15x146	NUT
554	MT578063	BLOCK
- -	MT1501216	Kit, Shear Bolt

FRONTIER MODEL ST0524

FACTORY MODEL 624504x16A HANDLE ASSEMBLY

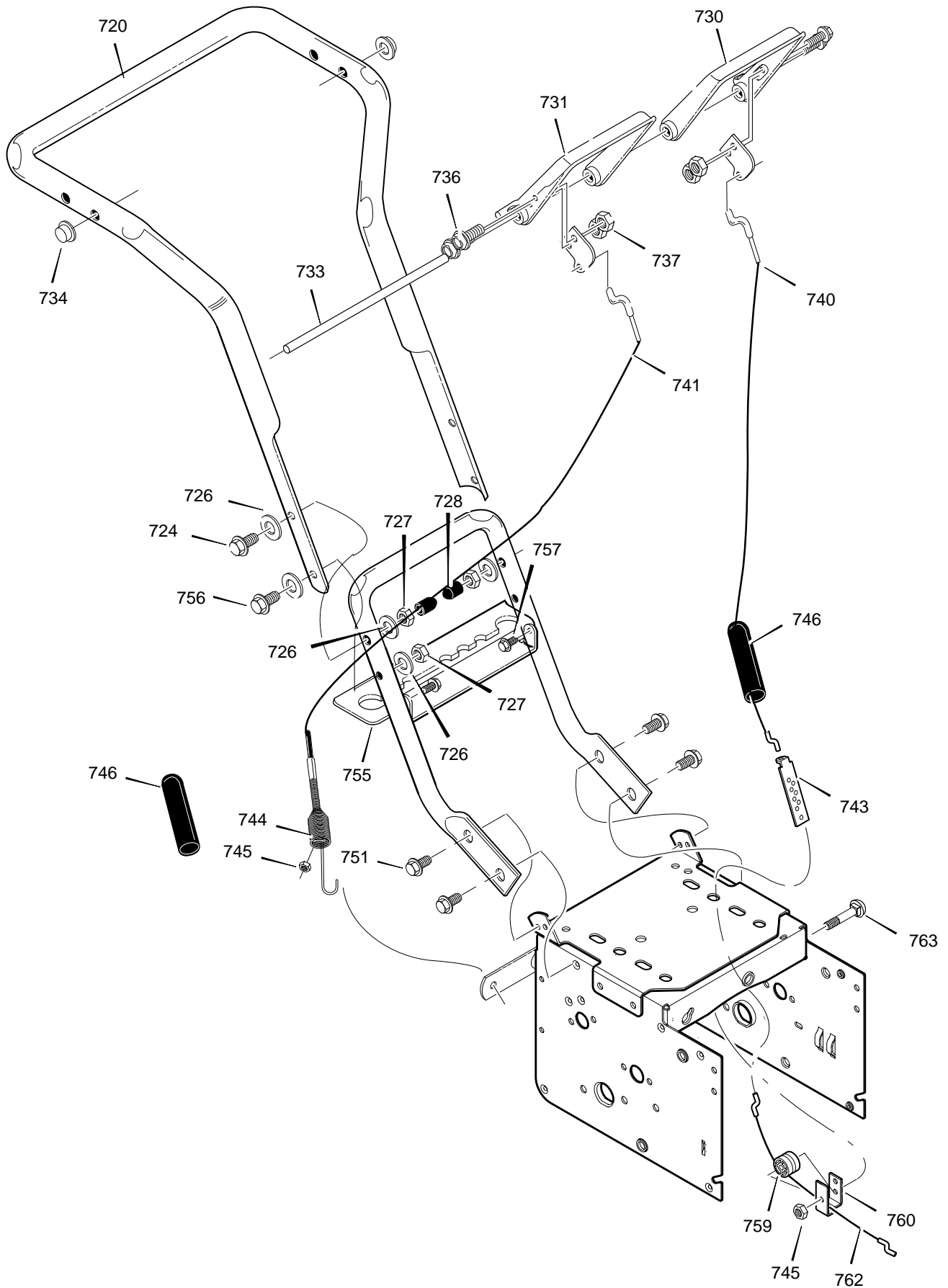

FRONTIER MODEL ST0524

FACTORY MODEL 624504x16A HANDLE ASSEMBLY

Key No.	Part No.	Description
720	MT9552E701	HANDLE
724	MT11234	SCREW
725	MT71071	WASHER, FLAT
726	MT71060	WASHER
727	MT15x144	NUT
728	MT11261	PLASTIC-ST OP
730	MT302557	CLUTCH, LEFT HANDLE CONTROL
731	MT302558	CLUTCH, RIGHT HANDLE CONTROL
733	MT12621	ROD, PIVOT HANDLE
734	MT3535	PUSH ON CAP
735	MT302620E701	PLATE, CABLE PIVOT
736	MT303108	SCREW
737	MT73826	NUT
740	MT1501123	CABLE, CLUTCH
741	MT761589	CABLE, AUGER CLUTCH
743	MT313441	BRKT, CABLE ADJUST
744	MT1673	SPRING, AUGER CLUTCH
745	MT15x145	LOCKNUT
746	MT308146	BOOT, CLUTCH SPRING
755	MT337407E701	BRACKET, GEAR SELECTOR
757	MT310169	SCREW, 1/4-20 X 0.63
750	MT339541E701	HANDLE, LOWER
751	MT70984	SCREW
752	MT71060	WASHER
759	MT579860	SPOOL-CABLE, AUGRT CLUTCH
760	MT1501059 YZ	BRACKET, CABLE SPOOL YZ
762	MT1501122	CABLE, LOWER DRIVE 12"
763	MT001798	BOLT, HEX 1/4-20 X 1.50 YZ

FRONTIER MODEL ST0524

FACTORY MODEL 624504x16A SHIFT YOKE

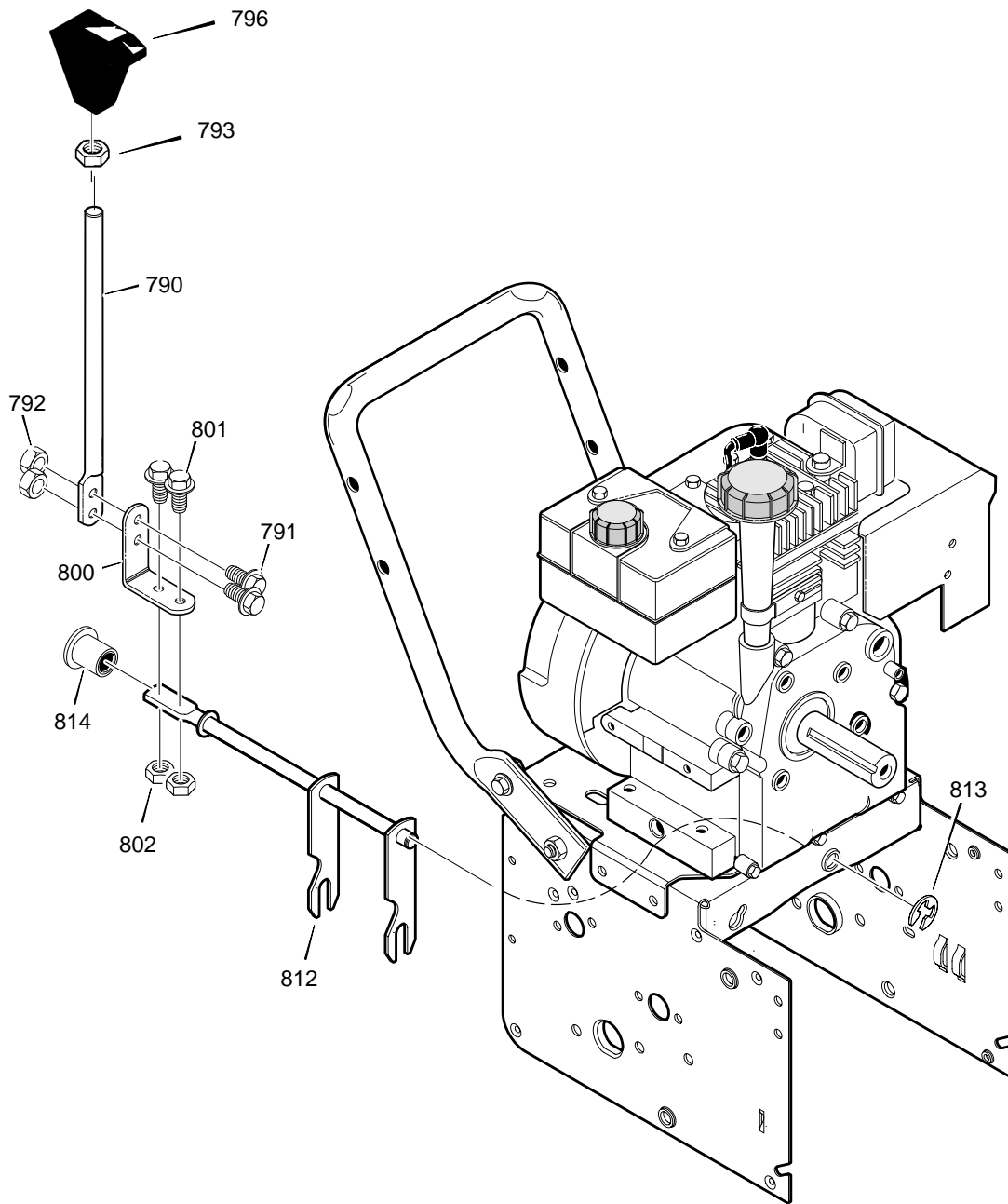

Key No.	Part No.	Description
790	MT581631E701	ROD, SHIFT
791	MT302628	SCREW, 1/4-20X.75
792	MT73826	NUT, 1/4-20
793	MT318486	NUT, JAM
796	MT304438	KNOB
800	MT760564	LEVER, SPRING
801	MT302628	SCREW, 1/4-20X.75
802	MT73826	NUT, 1/4-20
811	MT579944	BEARING, FLANGED
812	MT1501085 YZ	ROD ASSY., SPEED SELECT
813	MT11x30	RETAINER, RING

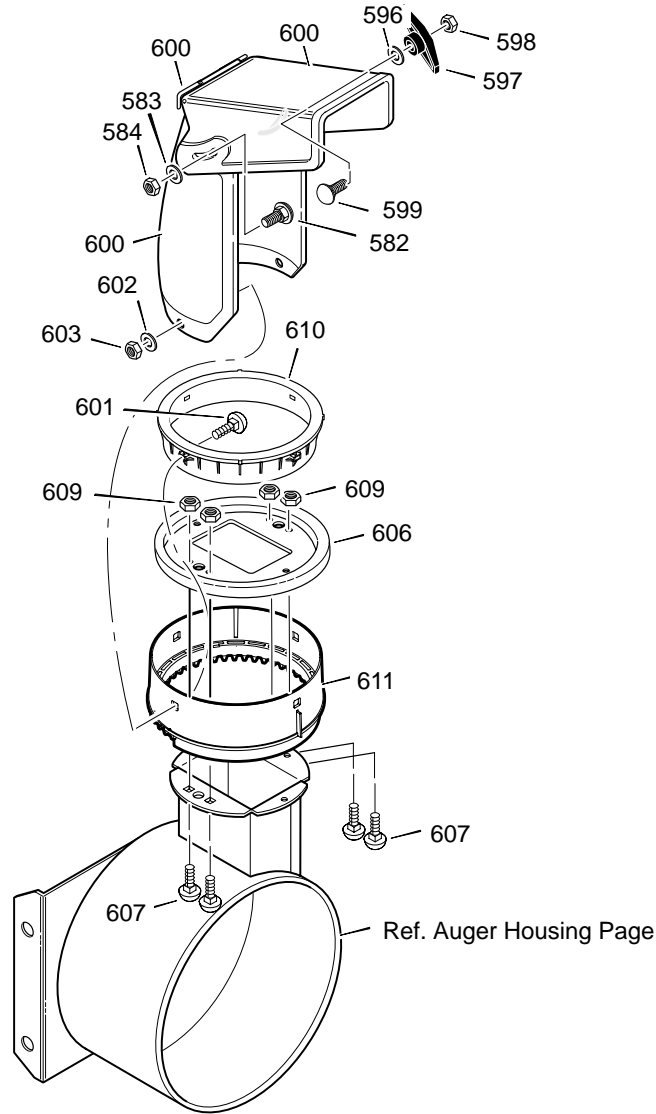

Key No.	Part No.	Description
582	MT2x100	SCREW, 5/16-18 X 1.00
583	MT71071	WASHER, FLAT
584	MT71038	NUT, 5/16-18
596	MT71071	WASHER
597	MT57171	KNOB, T 3.00
598	MT15X144	NUT, 5/16-18
599	MT2x100	BOLT, 5/16-18X1.00
600	MT762222	CHUTE ASSEMBLY
601	MT002x97	BOLT, 5/16-18
602	MT71071	WASHER, FLAT
603	MT71038	NUT, 5/16-18
606	MT585214 YZ	CHUTE COLLAR
607	MT02x101	SCREW, 1/4-20 X 0.75
609	MT15X145	NUT, 1/4-20 HEX NYLOCK
610	MT337227	RETAINER RING INNER
611	MT1501282	RETAINER RING OUTER

FRONTIER MODEL ST0524

FACTORY MODEL 624504x16A CHUTE ROD

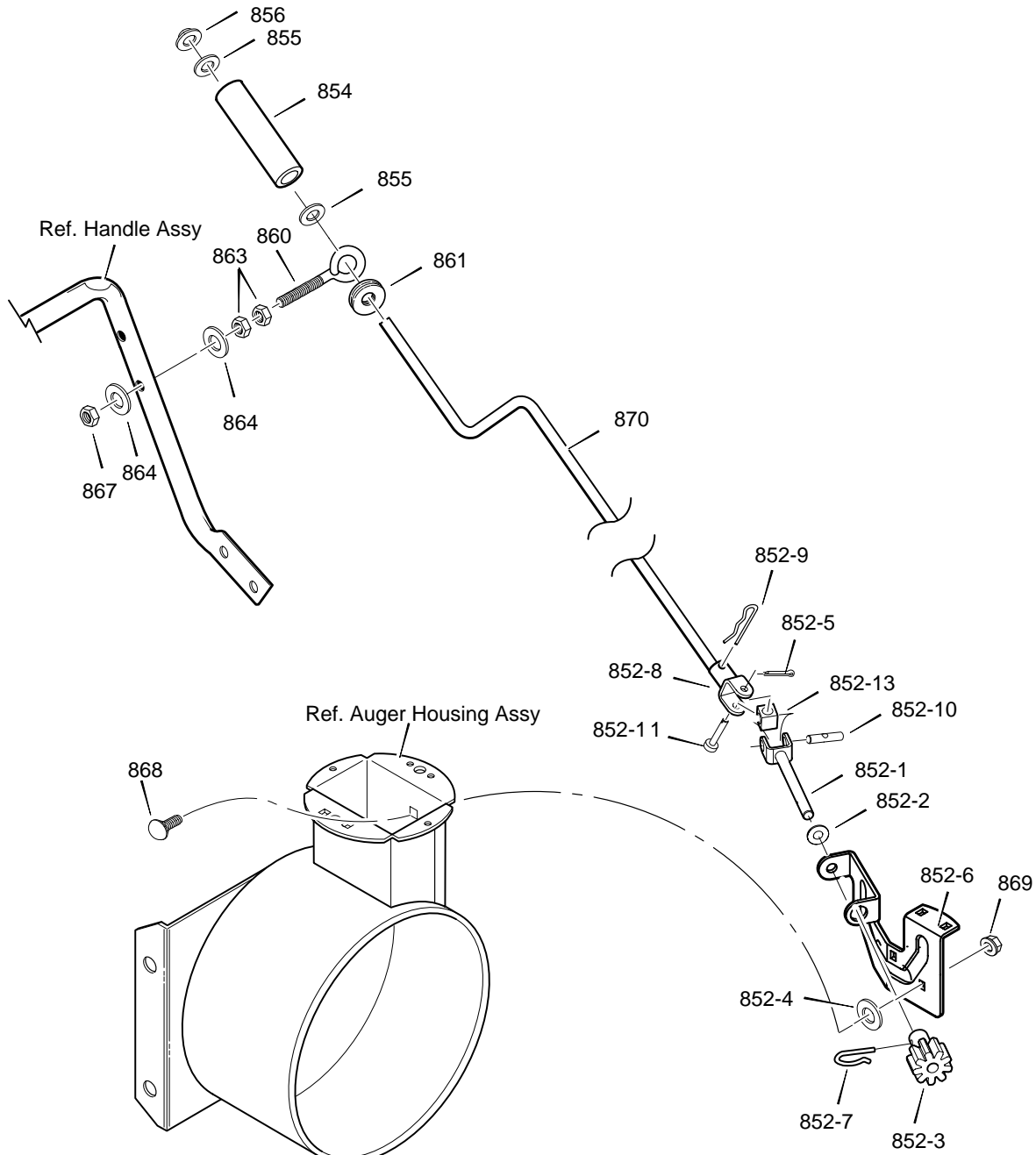

Key No.	Part No.	Description
852-1	MT1501309 YZ	ASSEMBLY, YOKE & ROD
852-2	MT313431	WASHER, CURVED SPRING
852-3	MT1501067	GEAR, CHUTE ROTATION 9T
852-4	MT17X170	WASHER
852-5	MT579493	PIN, COTTER
852-6	MT1501306E701	BRACKET, GEAR MOUNT
852-7	MT1501293	PIN, HAIR
852-8	MT1501075 YZ	ASSEMBLY, YOKE ADAPTER YZ
852-9	MT711682	PIN, HAIR
852-10	MT578060	PIN, UNIVERSAL JOINT
852-11	MT578309	PIN, CLEVIS
852-13	MT578063	HOUSING, UNIVERSAL

Key No.	Part No.	Description
854	MT51443	KNOB, SLEEVE
855	MT309312	FLATWASHER
856	MT73664	NUT, PUSH ON 3/8"
860	MT581618	EYE BOLT 3/8-16X6.00
861	MT148	GROMMET, EYE BOLT
863	MT71045	NUT, 3/8-16 HEXJAM
864	MT71072	FLATWASHER .406X.81X.066
867	MT71046	NUT, 3/8-16 HEXNYL
868	MT002X98	BOLT, CARRIAGE 1/4-20 X 1.00
869	MT15X145	NUT
870	MT1501074 YZ	CRANK, ASSY CHUTE

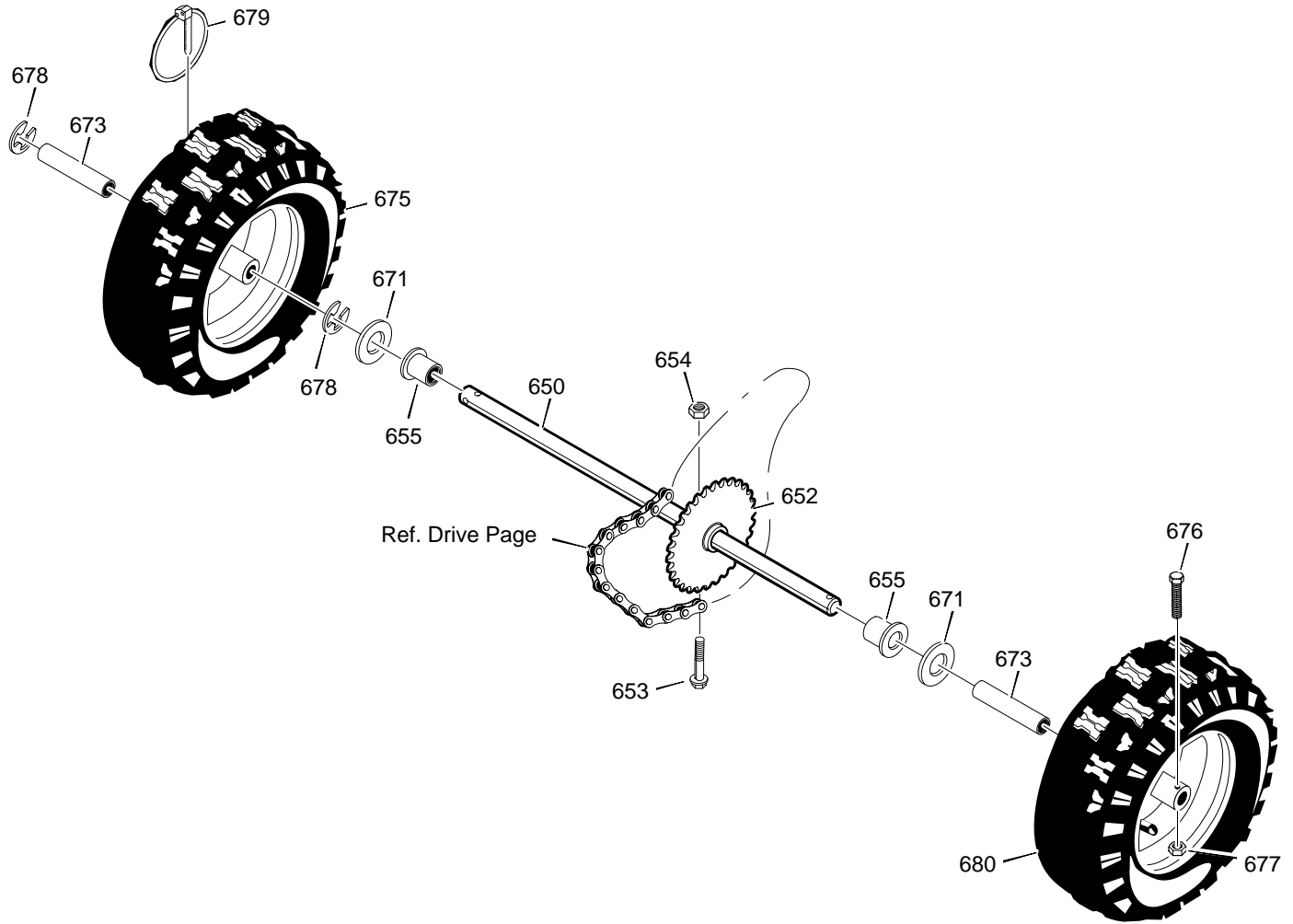

Key No.	Part No.	Description
650	MT1501562	SHAFT, AXLE
652	MT1501089	SPRKT & HUB
653	MT01x193	SCREW, 1/4-20 x 1.75
654	MT15x145	NUT, 1/4-20 HEX NYLOCK
655	MT1501114	BEARING, AXLE
671	MT712120	FLATWASHER
673	MT1501139	BUSHING, WHEEL
675	MT1501656	TIRE & RIM, RIGHT
676	MT577015	SCREW, 1/4-20X1.75 HH
677	MT15X145	NUT, 1/4-20 HEX NYLOCK
678	MT239	RING, RET
679	MT73842	PIN, KLIK .25 X 1.38 DIA
680	MT1501656	TIRE & RIM, LEFT

FRONTIER MODEL ST0524

FACTORY MODEL 624504x16A GEAR CASE

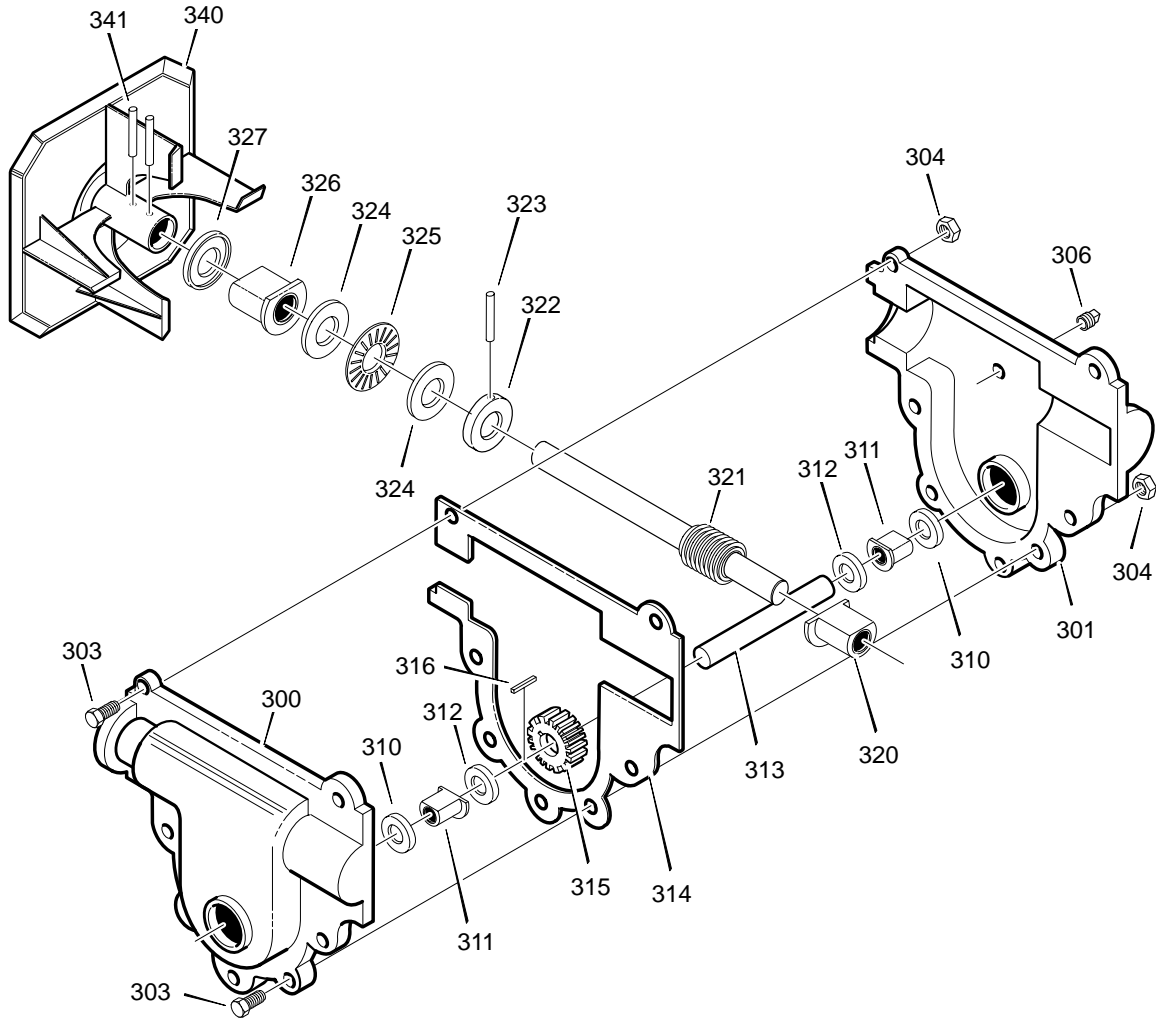

Key No.	Part No.	Description
	300	MT10577 CASE, GEAR, RH
	301	MT10576 CASE, GEAR, LH
	303	MT710025 SCREW, 1/4-20X.75
	304	MT15X143 NUT, 1/4-20
	306	MT9344 SCREW, 3/8-16X.50
	310	MT9566 SEAL, OIL
	311	MT50304 BEARING, FL
	312	MT48275 WASHER, FLAT
	313	MT340286 SHAFT, AUGER OUTPUT
	314	MT51279 GASKET, GEAR BOX
	315	MT51405 GEAR, WORM
	316	MT431787 KEY, WOODRUFF #61
	320	MT50221 BRNG, FL
	321	MT1501128 SHAFT, AUGER INPUT (IMPELLER)
	322	MT580295 COLLAR, THRUST
	323	MT454565 PIN, SPRING
	324	MT48275 WASHER, FLAT
	325	MT50684 BRNG, ROLL
	326	MT50304 BRNG, FL
	327	MT9566 SEAL, OIL
	340	MT760194E701 IMPELLER
	341	MT454565 PIN, SPRING
	*	MT333431 10oz TUBE LUBRIPLATE

*(NOT ILLUSTRATED)



IMPORTANT
OVER ADJUSTMENT OF FRICTION DISC WILL RESULT IN PERMANENT DAMAGE TO THE DRIVE TRAIN
NOT WARRANTED

“V” BELTS STRETCH UNDER NORMAL USE WHICH WILL AFFECT DISCHARGE PERFORMANCE AND SHOULD BE PERIODICALLY ADJUSTED. REFER TO MANUAL FOR INSTRUCTIONS.

DANGER
1. STOP ENGINE BEFORE UNCLOGGING DISCHARGE CHUTE OR AUGER HOUSING.
2. NEVER DIRECT DISCHARGE TOWARDS BYSTANDERS.
3. KEEP CLEAR OF AUGER HOUSING WHILE ENGINE IS RUNNING.
4. READ OWNERS MANUAL BEFORE OPERATING MACHINE.
AVOID INJURY FROM ROTATING AUGER-KEEP HANDS, FEET AND CLOTHING AWAY

Key No.	Part No.	Description
1	MT48x5283	DECAL, AUGER CONTROL
2	MT7390	DECAL, V-BELTS
3	MT7859	DECAL, OVER ADJUSTMENT
4	MT48x5286	DECAL, ROTATING AUGER
5	MT761078	DECAL, DANGER
6	MT48x5285	DECAL, UNCLOGGING CHUTE
7	MT48x5284	DECAL, SPEED CONTROL
9	MT760983	DECAL, SHEAR BOLTS
10	MT48x5287	LOGO, FRONTIER
11	MT48x5288	DECAL, ST0524
12	MT48x5254	DECAL, CLEAN & CLEAR BRUSH
13	MT586402	DECAL, TRACTON CONTROL
--	MTF-031071L	OPERATOR'S MANUAL

NOTES

NOTES

SPECIFICATIONS ST0524

Engine	Tecumseh Snow King
Horsepower	5 hp
Starter	Electric / Recoil
Fuel Capacity	2 quarts
Drive System	Friction Disc
Speeds	6 Forward / 2 Reverse
Tire Diameter	13"
Traction Control	Pin Lock
Clearing Width	24"
Housing Height	17.5"
Auger Diameter	10"
Auger Type	Steel / Notched
Impeller Diameter	9"
Chute Rotation	Remote
Chute Turning Radius	190°
Deflector Control	Manual
Weight	160 lbs
Warranty - Engine	2 years
Warranty - Machine	3 years



Free Manuals Download Website

<http://myh66.com>

<http://usermanuals.us>

<http://www.somanuals.com>

<http://www.4manuals.cc>

<http://www.manual-lib.com>

<http://www.404manual.com>

<http://www.luxmanual.com>

<http://aubethermostatmanual.com>

Golf course search by state

<http://golfingnear.com>

Email search by domain

<http://emailbydomain.com>

Auto manuals search

<http://auto.somanuals.com>

TV manuals search

<http://tv.somanuals.com>