



KENWOOD

SERVICE MANUAL

Model TV-502S



2m TRANSVERTER

CONTENTS

SPECIFICATIONS	3
CIRCUIT DESCRIPTION	4
CIRCUIT MODIFICATION	5
PARTS ALIGNMENT	7
PC BOARD	8
PARTS LIST	10
TROUBLESHOOTING	14
ADJUSTMENTS	15
REFERENCE	19
SCHEMATIC DIAGRAM	21

FEATURES

1. TV-502S is designed to be used in combination with TS-820S, TS-520S for 144 MHz operation.
2. Frequency range 144.0 MHz to 146.0 MHz.
3. Amplified ALC system is employed. ALC voltage fed back to transceiver minimizes distortion caused by over-driving, assuring quality transmission.
4. All-solid-state configuration with FET's employed in major circuits.
5. TV-502S provides of 145 MHz SSB mobile operation, when connecting TS-520 with DS-1.
6. Enjoyable excellent operation performance of TS-520 on 144 MHz band by connecting to TS-520.
7. Receiving antenna circuit incorporates highly sensitive tuning circuit to minimize radio interference.
8. Unique, functional design perfectly matches the styling of TS-520, VFO-520 and SP-520.
9. With minor modification of wiring, changeover between HF and VHF is effected by simply manipulating the Power Switch of TV-502.

SPECIFICATIONS

TRANSMITTING/RECEIVING FREQUENCY	144 ~ 145.7 MHz 145.0 ~ 146.0 MHz
INPUT/OUTPUT IF FREQUENCY	28.0 ~ 29.7 MHz
TYPE OF EMISSION	SSB (A3J) CW (A1)
RATED OUTPUT	8W (AC operation)
ANTENNA INPUT/OUTPUT IMPEDANCE	50 Ω
UNWANTED RADIATION	More than -60 dB
RECEIVING SENSITIVITY	More than 1 μ V at S/N 10 dB
IMAGE RATIO	More than 60 dB
IF REJECTION	More than 60 dB
FREQUENCY STABILITY	Less than \pm 2.5 kHz during 1 ~ 60 min after power ON within 150 Hz (per 30 min) thereafter.
POWER CONSUMPTION	AC 220/120 V Transmission 50W max Reception 12W max DC 13.8 V Transmission 2A max Reception 0.4A max
POWER REQUIREMENT	AC 220/120 V DC 12 ~ 16 V (standard voltage 13.8 V)
SEMICONDUCTOR	FET 5 Transistor 15 Diode 19
DIMENSIONS	6-9/16" (168 mm) wide x 5-15/16" (153 mm) high x 13-1/8" (336 mm) deep
WEIGHT	11.5 lbs. (5.2 kg)

FINAL TRANSISTOR SPECIFICATION

(2SC1242A ABSOLUTE MAX. RATINGS)

V _{CBO} :	35 V
V _{CEO} :	18 V
V _{EBO} :	3.5 V
I _C :	4.5 A
P _C :	30 W (T _C = 25° C)
T _j :	175° C
T _{stg} :	-65 ~ 175° C

CIRCUIT DESCRIPTION

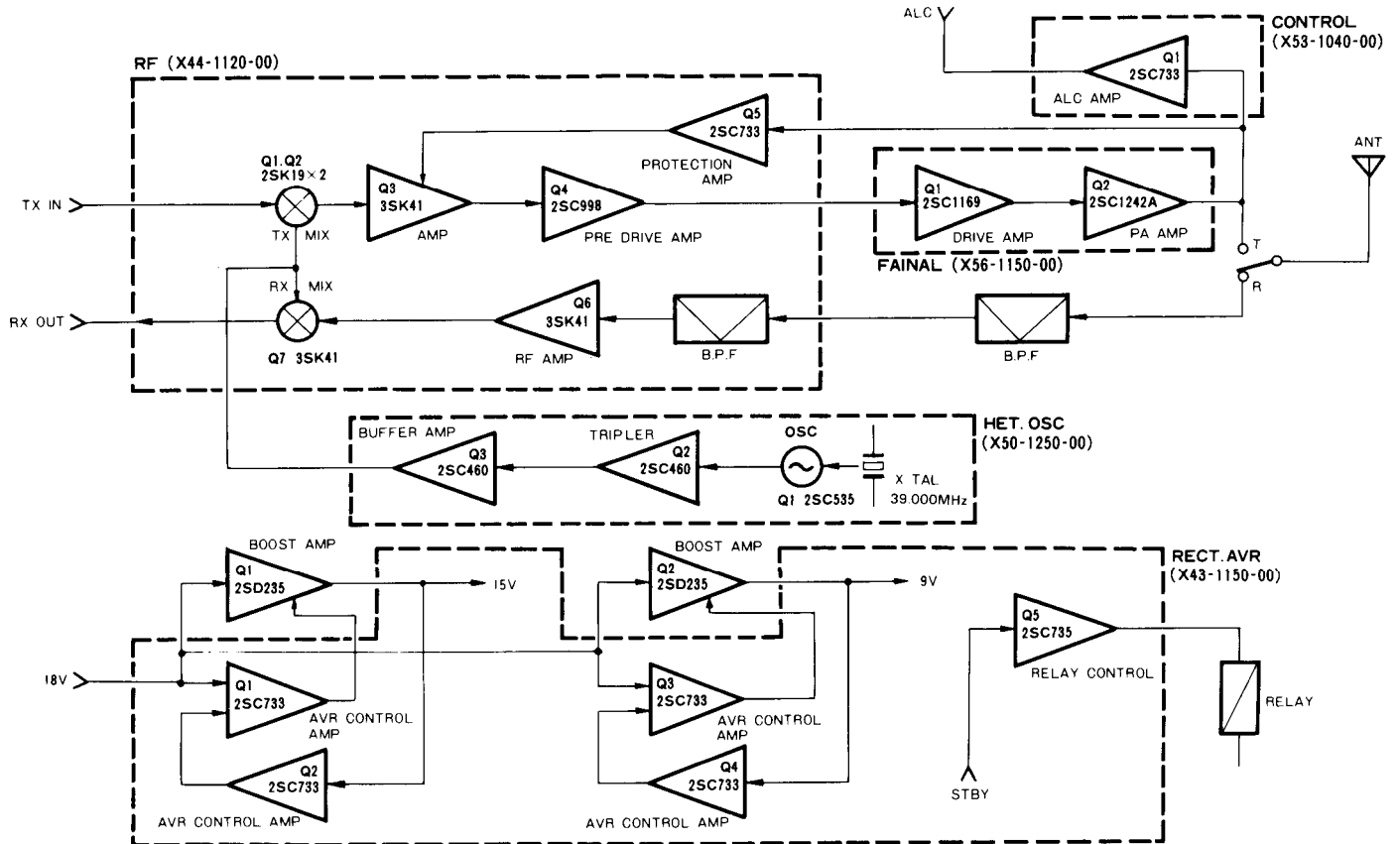

Fig. 1 TV-502 Block Diagram

Fig. 1 shows the block diagram of TV-502.

RF UNIT (X44-1120-00)

This unit is composed of an RF amplifier and mixer for reception, a balanced type mixer (2SK19 x 2) and 2-stages RF amplifier for transmission, and a final protection control circuit.

Receiving section

The 144 MHz signal from the antenna passes through the helical filter (T9) and is then applied to the 1st gate of RF amplifier FET (Q6: 3SK41). The signal thus amplified is fed to the 1st gate of the mixer (Q7: 3SK41) through the band pass filter consisting of T8 and T7, where the signal is converted into the 1st IF signal of 28 MHz band. After lowering the impedance by T6, it is picked up as transverter signal.

Transmitting section

The 28 MHz band signal fed from TS-520 is converted into 144 MHz band signal through the balanced mixer consisting of Q1 and Q2 (2SK19). The signal thus converted passes through the filter circuit (T2 ~ 5). It is amplified by Q3 (3SK41) and fed to the pre-driver Q4

(2SC998), resulting to the input signal for the final unit. The transistor Q5 (2SC733) is used to control the 2nd gate voltage of Q3 (3SK41) using the protection voltage supplied from the control unit (X53-1040-00).

FINAL UNIT (X56-1150-00)

This unit amplifies the signal, from the RF unit, up to the level of the rated output power. The output of the pre-driver (Q4: 2SC998) of the RF unit passes through the tuning circuit and is power-amplified by the driver (Q1: 2SC1169), and furthermore amplified to the rated power level through the final stage power transistor (Q2: 2SC1242A). The amplified signal passes through the low pass filter (LPF) composed of L7, C12, L8 and C13 to remove the higher harmonics component, and becomes output signal.

The diodes D1 and D2 (1S1555) are used to provide each transistor with a proper bias, utilizing forward voltage to keep bias variations minimum in regard to temperature.

CIRCUIT DESCRIPTION/MODIFICATION

HET OSCILLATOR UNIT (X50-1250-00)

This is a local oscillator unit for frequency conversion. The fundamental oscillation frequency (38.666 MHz, 39.000 MHz) is oscillated by Q1 (2SC535) and tripled by Q2 (2SC460) up to 116.0 MHz and 117 MHz of local oscillation frequency. It passes through the spurious rejection filter circuit consisting of T2 and T3 and is fed to the buffer amplifier Q3 (2SC460) where the impedance is lowered to obtain necessary output.

This unit has a built-in crystal for 38.666 MHz, 39.000 MHz as a standard, and is designed to obtain 117 MHz of local oscillation frequency by inserting a crystal for 39.000 MHz. Switching the band selector, this changeover is accomplished by the diode switch consisting of D1 and D2 (1N60).

CONTROL UNIT (X53-1040-00)

This unit incorporates an ALC detector circuit, protection detector circuit and RF meter circuit.

In the ALC detector circuit, the output voltage is divided by C5 (1pF) and C4 (22pF) and rectified by D2 and D3 (1N60). It is then amplified by Q1 (2SC733) to obtain ALC voltage which is feedbacked to TS-520 to control the drive voltage.

In the protection detector circuit, the reflected wave power obtained from the circuit line in parallel with the signal line and from the detector coil (L5) is rectified through D4 (1N60) for necessary output.

And in the meter circuit, the output voltage is divided and rectified by C12 (1pF) and C11 (5pF). The meter sensitivity can be adjusted by the 100 k Ω PC trimmer potentiometer (VR1).

RECTIFIER/AVR UNIT (X43-1150-00)

Included in this unit are a rectifier circuit, 9 V power stabilizer circuit, 15 V power stabilizer circuit, and a relay drive circuit. The transistors Q1 and Q2 (2SD235), used to control the 9 V and 15 V stabilized power, are mounted on the heat sink of the final unit, while the transistors Q1 and Q3 (2SC733) are Darlington connected to the 9 V and 15 V stabilized power control transistors (Q1, Q2) for driving.

The transistors Q2 and Q4 (2SC733) are the error voltage detector transistors for 9 V and 15 V of power voltages, and are used for comparison with the reference voltages from D5 (WZ-090) and D6 (WZ-061). The transistor Q5 (2SC735) is the relay drive transistor and D7 (V06B) is the diode to erase the spike voltage caused by the relay.

The rectifier circuit is the bridge connected circuit using D1 ~ 4 (U05B).

Care should be used not to short the 9 V/15 V lines to the chassis, since the power stabilizer circuits are not provided with protection circuits.

CIRCUIT CHANGE

Although TS-520 works satisfactorily when only connected to TV-502, it is also designed to permit simple changes in the circuit to offer the following operating advantages:

1. The operating band of VHF or HF can be selected with the POWER switch on TV-502.
2. As the final (S2001) screen voltage of TS-520 is automatically switched, the SG switch of TS-520 may be left ON (up) position at all times.

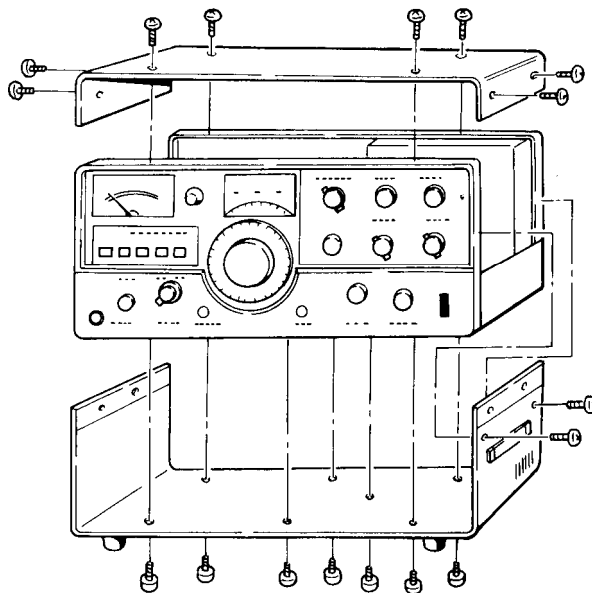

Fig. 2

Preparation and Precaution for Circuit Change:

1. Disconnect the power cord of TS-520.
2. Remove the case from the unit (see Fig. 2).
3. Short the high voltage circuit to the chassis for a short period of time using a screwdriver in order to prevent electric shock.

Method of Circuit Change:

Only the X VERTOR connector circuit may be changed. Do not touch any other circuits. To change, remove the lead wire connected between the pins 6-7 and the other lead wire connected between the pins 3-10 by referring to Fig. 4.

Be very sure that other lead wires remain as they are.

NOTE: On earlier produced TS-520, solder both the earth line of coaxial cable (A) and (B) to twelfth terminal (see Fig. 4), which are open.

After the change of the connector circuit, replace the upper lid and the bottom plate.

If TS-520 is to be operated without connecting TV-502, make sure to insert the supplied 12P shorting plug into the X VERTOR connector. Fig. 5 shows the internal connection of the 12P shorting plug.

CIRCUIT MODIFICATION

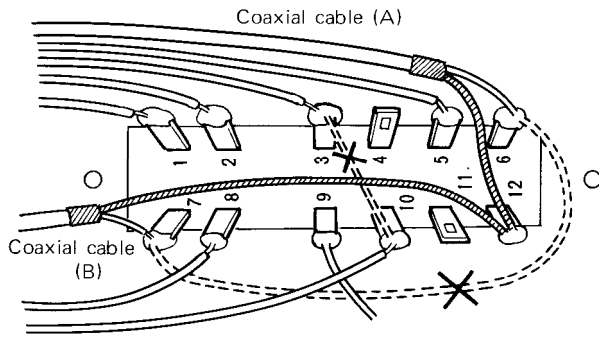

Fig. 4 Change of TS-520 X VERTOR Connector Circuit

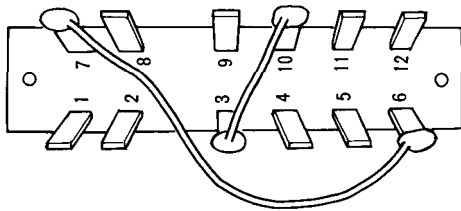

Fig. 5 Internal View of 12P Shorting Plug

DC Power Operation:

TV-502 can be operated on DC power. In this case, TS-520 must be equipped with DS-1. When the supplied DC power 2P plug is used, the AC-DC selector switch on the rear panel should be set to the DC position (this switch is set to "AC" when shipment) and a fuse (3A) should be provided along the DC cord.

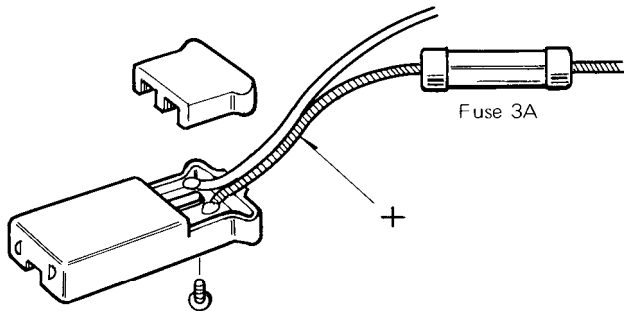
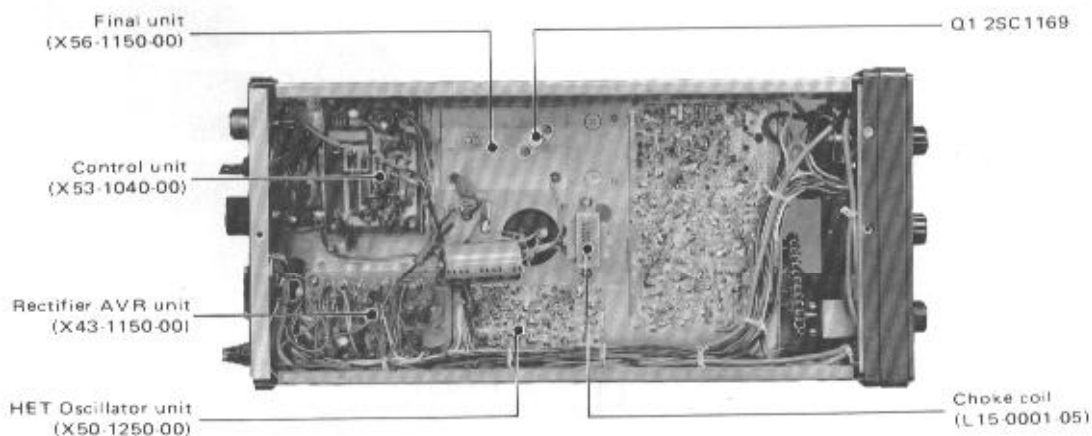
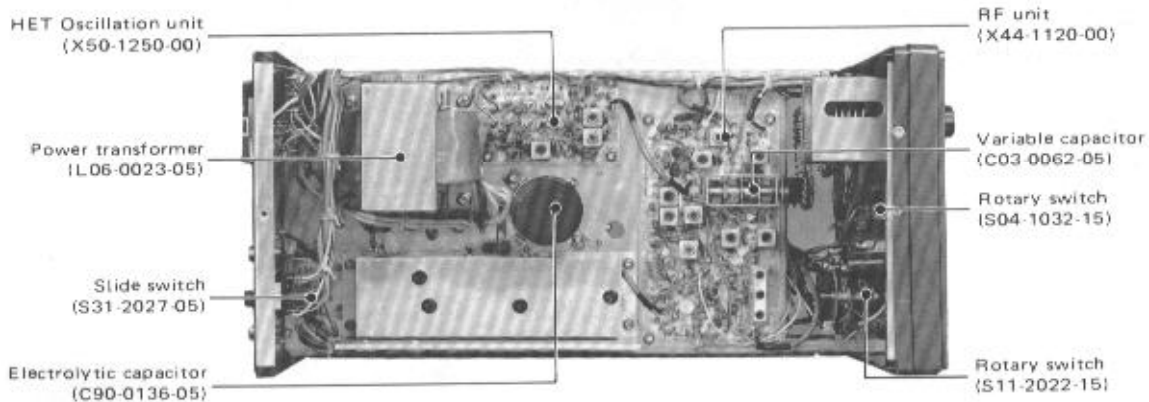
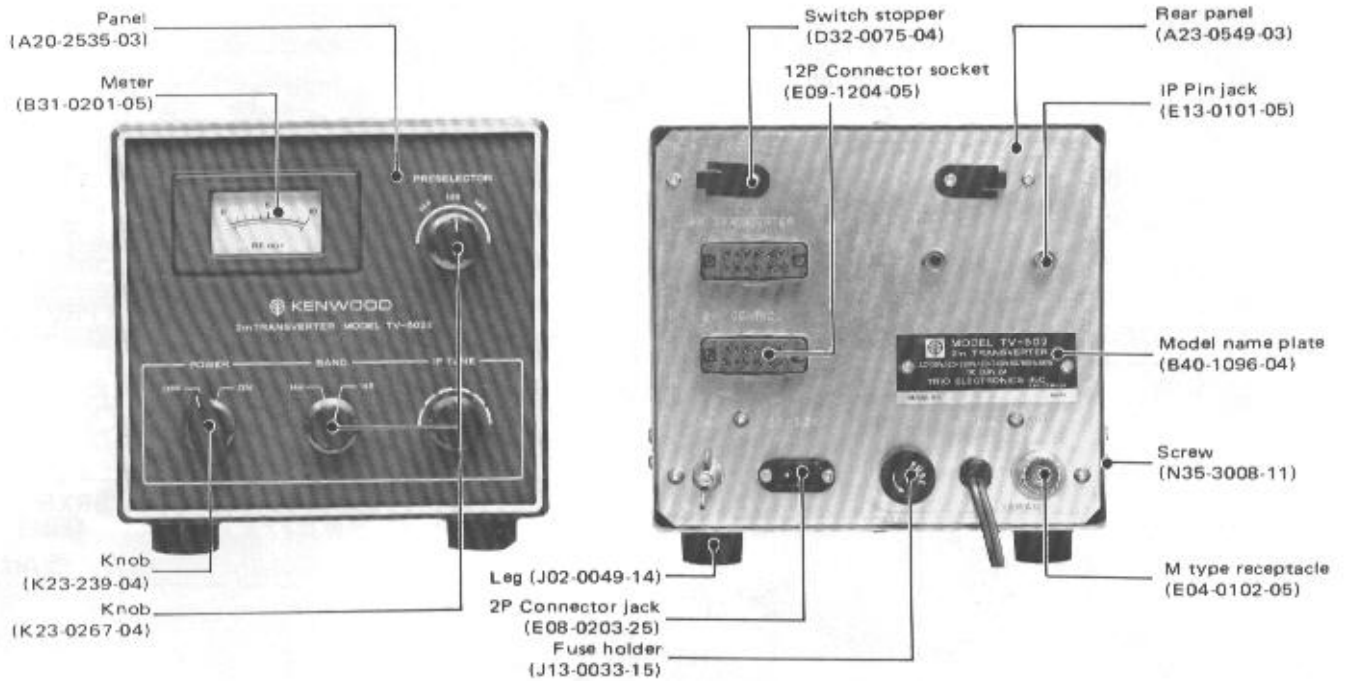

Fig. 6 Connection of DC Plug

PARTS ALIGNMENT



PC BOARD

▼ RF (X44-1120-00)

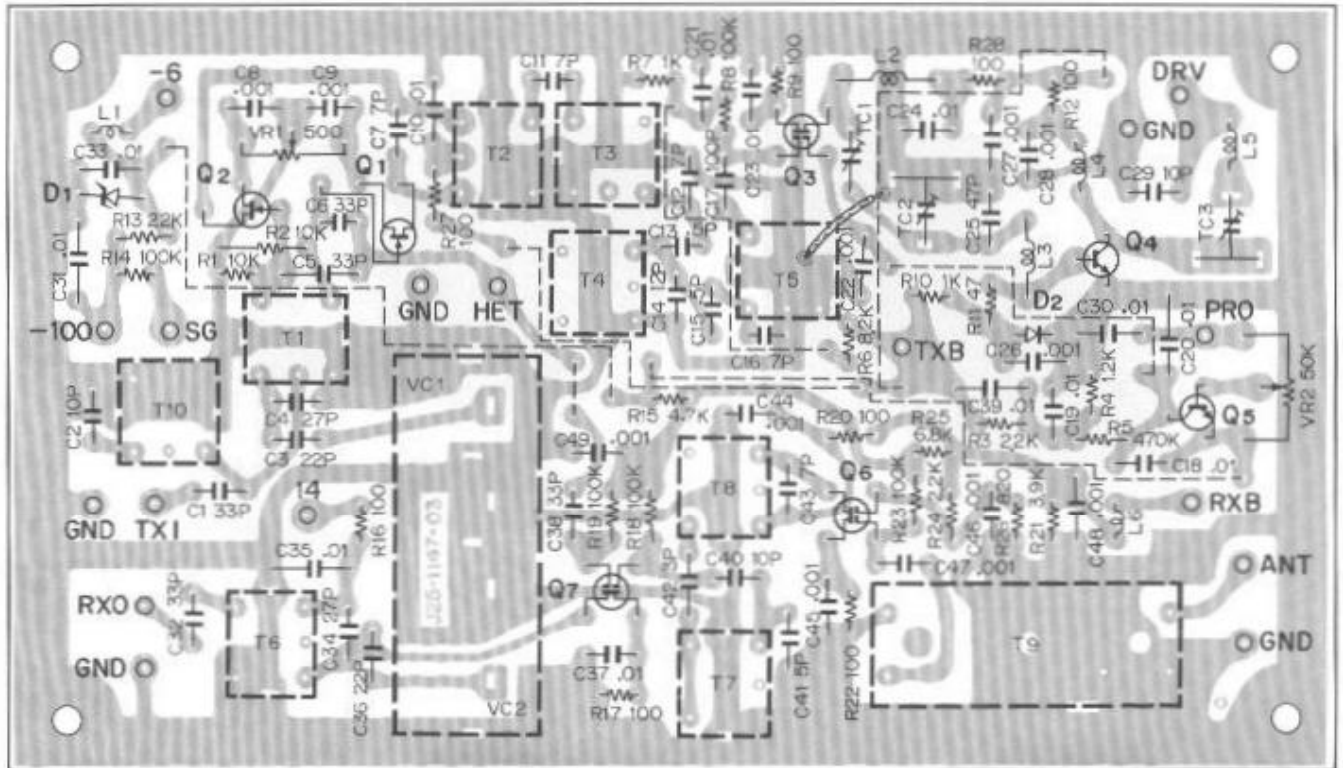

Q1,2: 2SK19 (GR), Q3,6,7: 3SK41 (L), Q4: 2SC998, Q5: 2SC733 (Y), D1: WZ-061, D2: IS 1555

2SK19 (GR)



3SK41 (L)

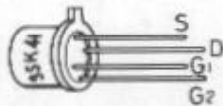

2SC998

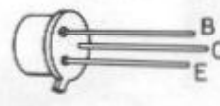

2SC733 (Y)



▼ FINAL (X56-1150-00)

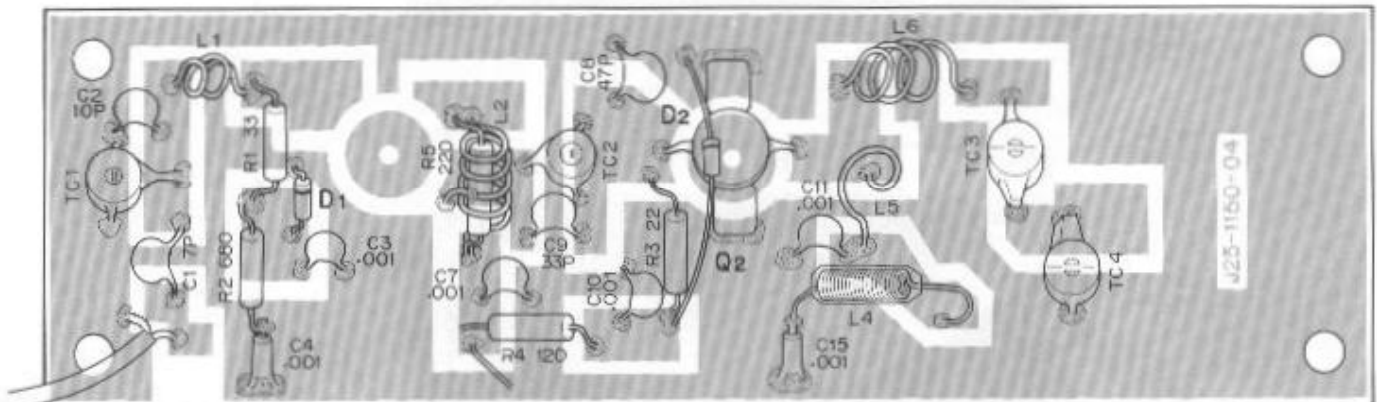

Q2: 2SC1242A, D1,2: IS 1555

2SC1242A

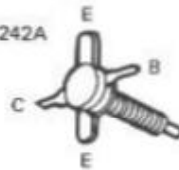

PC BOARD

▼ RECTIFIER AVR (X43-1150-00)

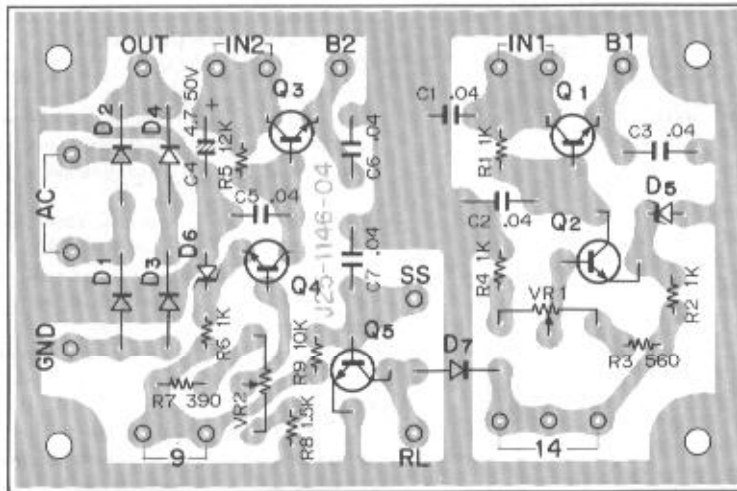

Q1~4: 2SC733(Y), D1~4: U05B, D5: WZ090, D6: WZ061
Q5 : 2SC735(Y) D7: V06B

2SC733 (Y)
2SC735 (Y)



▼ CONTROL (X53-1040-00)

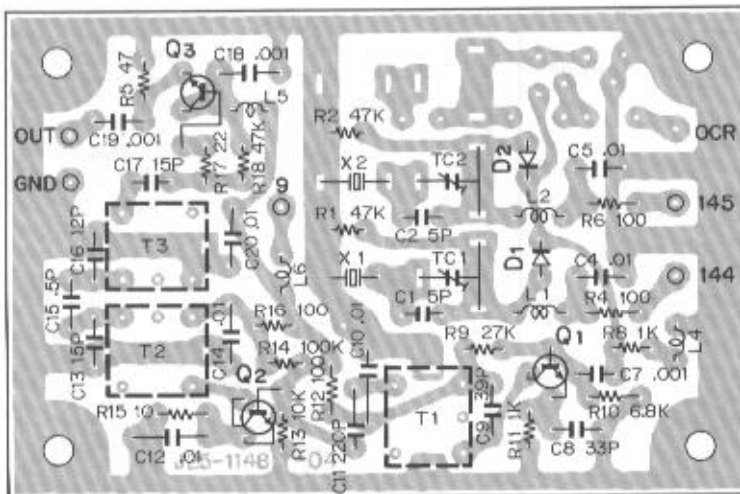

Q1: 2SC535(A), Q2,3: 2SC460(B), D1,2: IN60

2SC535 (A)
2SC460 (B)

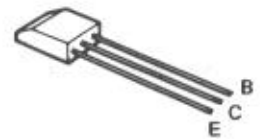

▼ HET. OSC. (X50-1250-00)

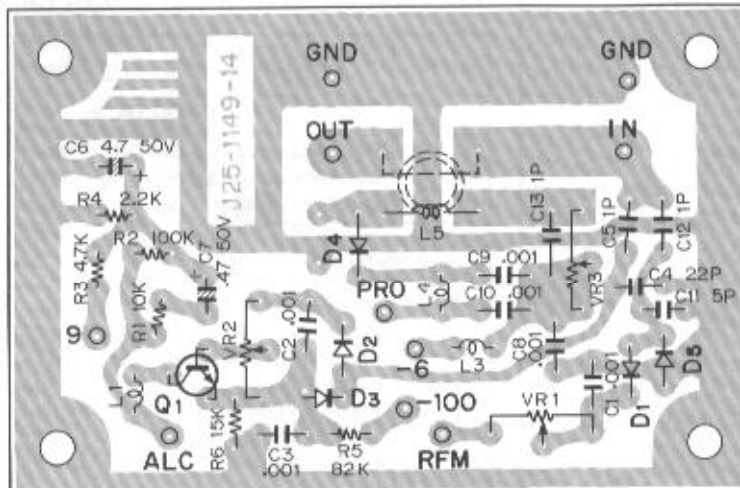

Q1: 2SC733 (Y), D1~5: IN60

2SC733 (Y)



PARTS LIST

TV-502 TRANSVERTER (Overall parts list)

Ref. No.	Parts No.	Description	Re- marks
CAPACITOR			
C1	CK45F1H103Z	Ceramic 0.01 μ F +80%,-20%	
C2, 3	CK45F1E403Z	Ceramic 0.04 μ F +80%,-20%	
C4	CE02W1E222	Electrolytic 2200 μ F 25WV	
C5, 6	CK45F1E403Z	Ceramic 0.04 μ F +80%,-20%	
C7	C90-0136-05	Electrolytic 6800 μ F 35WV	
C8	CK45F1H103Z	Ceramic 0.01 μ F +80%,-20%	
C9	CC45SL2H020C	Ceramic 2pF \pm 0.25pF	
C10	CK45F1E403Z	Ceramic 0.04 μ F +80%,-20%	
RESISTER			
R1	RN14AB3D100J	Metal film 10 Ω \pm 5% 2W	
SEMICONDUCTOR			
D1	V11-0270-05	Diode U05B	
TRANSFORMER / COIL			
T1	L06-0032-05	Power transformer	
CH1	L15-0001-15	Choke coil (low frequency)	
L1	L33-0074-05	Choke coil (heater) (0.3 μ H)	
L2, 3	L40-1011-03	Ferri-inductor x 2 (100 μ H)	
-	L34-0475-05	VHF coil	
-	L34-0476-05	VHF coil	
SWITCH			
S1	S11-2022-15	Rotary switch	
S3	S04-1032-15	Rotary switch	
S4, 5	S31-2027-05	Slide switch x 2	
MISCELLANEOUS			
-	A01-0255-02	Case (A)	
-	A01-0256-02	Case (B)	
-	A10-0413-11	Chassis	
-	A20-2535-03	Panel	
-	A22-0166-13	Sub-panel	
-	A23-0549-03	Rear panel	
-	B01-0078-23	Escutcheon	
-	B30-0002-05	Pilot lamp (12V, 3W)	
M	B31-0201-05	Meter	
-	B40-1096-04	Model name plate	
-	B42-0545-04	Sticker (fuse)	
-	B58-0194-00	Caution card	
-	B50-1300-00	Operation manual	
-	B58-0190-00	Caution card (Power supply voltage) (TAG)	
-	B58-0191-00	Caution card (Power supply voltage)	
-	D13-0032-03	Sprocket	
-	D16-0050-04	Chain assembly	
-	D20-0108-04	Dial shaft	
-	D32-0075-04	Switch stopper x 3	
-	E03-0301-05	Plug	
J5	E04-0102-05	M type receptacle	
J6	E08-0203-25	2P connector jack	
J3, 4	E08-1208-05	12P connector socket x 2	
-	E09-0203-15	2P connector plug	
-	E09-1204-05	12P connector plug x 3	
J1, 2	E13-0101-05	1P jack x 2	
-	E14-0115-05	1P plug x 3	
-	E15-0038-05	Pilot socket	
-	E19-0207-05	Plug (interchangeable)	

Ref. No.	Parts No.	Description	Re- marks
-	E22-0216-05	Lug x 3	
-	E22-0415-05	Lug	
-	E23-0055-05	Hermetic seal	
-	E23-0069-05	Terminal (for grand cable) x 2	
-	E23-0071-04	Lug (antenna earth)	
-	E30-0019-05	Connecting cable	
-	F05-1023-05	Fuse (1A, 100V) x 2	
-	F05-5013-05	Fuse (0.5A, 220V) x 2	
-	F07-0365-04	Cover (filter case)	
-	F07-0366-04	Cover (filter case)	
-	F11-0211-04	Filter case	
-	F19-0184-04	Meter stopping plate	
-	J02-0049-14	Leg x 6	
-	J13-0033-15	Fuse holder	
-	J19-0452-04	Transformer retainer x 2	
-	J21-0392-04	Lead holder	
-	J32-1030-14	Round boss x 2	
-	J41-0024-15	Cord bushing	
-	J61-0014-05	Free up belt	
-	J61-0019-05	Cable wrapping band x 7	
-	K21-0267-04	Knob x 3	
-	K23-0239-04	Knob	
-	N35-3008-11	Screw x 16	
RL1	S51-4017-25	Relay	
-	H01-1275-04	Carton case	
-	H03-0387-04	Carton case (external)	
-	H10-1200-02	Buffer fixture x 2	
-	H10-1201-04	Buffer fixture	
-	H20-0276-03	Protection bag	
-	H25-0016-00	Polyethylene bag	
-	H25-0105-04	Protection bag	
-	X43-1150-00	Rectifier AVR unit	
-	X44-1120-00	RF unit	
-	X50-1250-00	HET oscillator unit	
-	X53-1040-00	Control unit	
-	X56-1150-00	Final unit	

RECTIFIER AVR UNIT (X43-1150-00)

Ref. No.	Parts No.	Description	Re- marks
CAPACITOR			
C1 ~ 3	CK45F1E403Z	Ceramic 0.04 μ F +80%-20%	
C4	CE04W1H4R7(RL)	Electrolytic 4.7 μ F 50WV	
C5 ~ 7	CK45F1E403Z	Ceramic 0.04 μ F +80%-20%	
RESISTOR			
R1, 2	PD14CY2E102J	Carbon 1k Ω \pm 5% 1/4W	
R3	PD14CY2E561J	Carbon 560 Ω \pm 5% 1/4W	
R4	PD14CY2E102J	Carbon 1k Ω \pm 5% 1/4W	
R5	PD14CY2E123J	Carbon 12k Ω \pm 5% 1/4W	
R6	PD14CY2E102J	Carbon 1k Ω \pm 5% 1/4W	
R7	PD14CY2E391J	Carbon 390 Ω \pm 5% 1/4W	
R8	PD14CY2E152J	Carbon 1.5k Ω \pm 5% 1/4W	
R9	PD14CY2E103J	Carbon 10k Ω \pm 5% 1/4W	

PARTS LIST

Ref. No.	Parts No.	Description	Re- marks
SEMICONDUCTOR			
Q1 ~ 4	V03-0123-05	Transistor 2SC733 (Y)	
Q5	V03-0241-09	Transistor 2SC735 (Y)	
D1 ~ 4	V11-0270-05	Diode U05B	
D5	V11-0240-05	Zener diode WZ-090	
D6	V11-0243-05	Zener diode WZ-061	
D7	V11-0219-05	Diode V06B	
POTENTIOMETER			
VR1	R12-1020-05	Volume 1k Ω	
VR2	R12-0042-05	Volume 500 Ω	
MISCELLANEOUS			
—	E23-0047-04	Terminal x 17	
—	J25-1146-04	PC board	

RF UNIT (X44-1120-00)

Ref. No.	Parts No.	Description	Re- marks
CAPACITOR			
C1	CC45SL1H330J	Ceramic 33pF $\pm 5\%$	
C2	CC45CH1H100J	Ceramic 10pF $\pm 5\%$	
C3	CC45CH1H220J	Ceramic 22pF $\pm 5\%$	
C4	CC45CH1H270J	Ceramic 27pF $\pm 5\%$	
C5, 6	CC45SL1H330J	Ceramic 33pF $\pm 5\%$	
C7	CC45CH1H070D	Ceramic 7pF $\pm 0.5pF$	
C8, 9	CC45D1H102M	Ceramic 0.001 μF $\pm 20\%$	
C10	CK45F1H103ZTP	Ceramic 0.01 μF $+80\%, -20\%$	
C11	CC45SL1H070D	Ceramic 7pF $\pm 0.5pF$	
C12	CC45CH1H070D	Ceramic 7pF $\pm 0.5pF$	
C13	C90-0231-05	Ceramic 0.5pF $\pm 0.5pF$	
C14	CC45CH1H120J	Ceramic 12pF $\pm 5\%$	
C15	C90-0231-05	Ceramic 0.5pF $\pm 0.5pF$	
C16	CC45CH070D	Ceramic 7pF $\pm 0.5pF$	
C17	CC45SL1H101J	Ceramic 100pF $\pm 5\%$	
C18~21	CK45F1H103ZTD	Ceramic 0.01 μF $+80\%, -20\%$	
C22	CK45D1H102M	Ceramic 0.001 μF $\pm 20\%$	
C23, 24	CK45F1H103ZTD	Ceramic 0.01 μF $+80\%, -20\%$	
C25	CC45SL1H470J	Ceramic 470pF $\pm 5\%$	
C26~28	CK45D1H102M	Ceramic 0.001 μF $\pm 20\%$	
C29	CC45SL1H100D	Ceramic 10pF $\pm 0.5pF$	
C30, 31	CK45F1H103ZTD	Ceramic 0.01 μF $+80\%, -20\%$	
C32	CC45SL1H330J	Ceramic 33pF $\pm 5\%$	
C33	CK45F1H103ZTD	Ceramic 0.01 μF $+80\%, -20\%$	
C34	CC45CH1H270J	Ceramic 27pF $\pm 5\%$	
C35	CK45F1H103ZTD	Ceramic 0.01 μF $+80\%, -20\%$	
C36	CC45CH1H220J	Ceramic 22pF $\pm 5\%$	
C37	CK45F1H103ZTD	Ceramic 0.01 μF $+80\%, -20\%$	
C38	CC45SL1H330J	Ceramic 33pF $\pm 5\%$	
C39	CK45F1H103ZTD	Ceramic 0.01 μF $+80\%, -20\%$	
C40	CC45SL1H100D	Ceramic 10pF $\pm 0.5pF$	
C41	CC45CH1H050D	Ceramic 5pF $\pm 0.5pF$	
C42	CC45SL1H030D	Ceramic 3pF $\pm 0.5pF$	
C43	CC45CH1H070D	Ceramic 7pF $\pm 0.5pF$	
C44~49	CK45D1H102M	Ceramic 0.001 μF $\pm 20\%$	
C50	CK45F1H103Z	Ceramic 0.01 μF $+80\%, -20\%$	
C51	CK45F1E403Z	Ceramic 0.04 μF $+80\%, -20\%$	

Ref. No.	Parts No.	Description	Re- marks
RESISTOR			
R1, 2	PD14CY2E103J	Carbon 10k Ω $\pm 5\%$ 1/4W	
R3	PD14CY2E222J	Carbon 2.2k Ω $\pm 5\%$ 1/4W	
R4	PD14CY2E122J	Carbon 1.2k Ω $\pm 5\%$ 1/4W	
R5	PD14CY2E474J	Carbon 470k Ω $\pm 5\%$ 1/4W	
R6	PD14CY2E822J	Carbon 8.2k Ω $\pm 5\%$ 1/4W	
R7	PD14CY2E102J	Carbon 1k Ω $\pm 5\%$ 1/4W	
R8	PD14CY2E104J	Carbon 100k Ω $\pm 5\%$ 1/4W	
R9	PD14CY2E101J	Carbon 100 Ω $\pm 5\%$ 1/4W	
R10	PD14CY2E102J	Carbon 1k Ω $\pm 5\%$ 1/4W	
R11	PD14CY2E470J	Carbon 47 Ω $\pm 5\%$ 1/4W	
R12	PD14CY2E101J	Carbon 100 Ω $\pm 5\%$ 1/4W	
R13	RC05GF2H223J	Carbon 22k Ω $\pm 5\%$ 1/2W	
R14	RN14AB3D104J	Metal film 100k Ω $\pm 5\%$ 2W	
R15	PD14CY2E472J	Carbon 4.7k Ω $\pm 5\%$ 1/4W	
R16, 17	PD14CY2E101J	Carbon 100 Ω $\pm 5\%$ 1/4W	
R18, 19	PD14CY2E104J	Carbon 100k Ω $\pm 5\%$ 1/4W	
R20	PD14CY2E101J	Carbon 100 Ω $\pm 5\%$ 1/4W	
R21	PD14CY2E392J	Carbon 3.9k Ω $\pm 5\%$ 1/4W	
R22	PD14CY2E101J	Carbon 100 Ω $\pm 5\%$ 1/4W	
R23	PD14CY2E104J	Carbon 100k Ω $\pm 5\%$ 1/4W	
R24	PD14CY2E222J	Carbon 2.2k Ω $\pm 5\%$ 1/4W	
R25	PD14CY2E682J	Carbon 6.8k Ω $\pm 5\%$ 1/4W	
R26	PD14CY2E821J	Carbon 820 Ω $\pm 5\%$ 1/4W	
R27, 28	PD14CY2E101J	Carbon 100 Ω $\pm 5\%$ 1/4W	

Ref. No.	Parts No.	Description	Re- marks
SEMICONDUCTOR			
Q1, 2	V09-0012-05	FET 2SK19 (GR)	
Q3	V09-0057-05	FET 3SK41 (L)	
Q4	V03-0168-05	Transistor 2SC998	
Q5	V03-0123-05	Transistor 3SC733 (Y)	
Q6, 7	V09-0057-05	FET 3SK41 (L)	
D1	V11-0243-05	Zener diode WZ-061	
D2	V11-0263-05	Diode 1S1555	

Ref. No.	Parts No.	Description	Re- marks
COIL			
T1	L31-0348-05	Tuning coil (28 MHz)	
T2	L31-0349-05	Tuning coil (BM)	
T3	L31-0350-05	Tuning coil (144 MHz)	
T4	L31-0266-05	Tuning coil (144 MHz)	
T5	L31-0267-05	Tuning coil (144 MHz)	
T6	L31-0348-05	Tuning coil (28 MHz)	
T7, 8	L31-0350-05	Tuning coil (144 MHz)	
T9	L79-0022-05	Helical filter	
T10	L31-0266-05	Tuning coil (144 MHz)	
L1	L40-1011-03	Ferri-inductor (100 μH)	
L2	L34-0388-05	VHF coil	
L3	L34-0432-05	VHF coil	
L4, 5	L34-0430-05	VHF coil	
L6	L34-1511-03	Ferri-inductor (150 μH)	

Ref. No.	Parts No.	Description	Re- marks
VARIABLE CAPACITOR / TRIMMER			
VC1,2	C01-0166-15	Variable capacitor (29P x 4)	
TC1	C05-0030-15	Ceramic trimmer (20PF)	
TC2,3	C05-0015-15	Ceramic trimmer (40PF)	

Ref. No.	Parts No.	Description	Re- marks
POTENTIOMETER			
VR1	R12-0042-05	Volume 500 Ω	
VR2	R12-4016-05	Volume 50k Ω	

Ref. No.	Parts No.	Description	Re- marks
MISCELLANEOUS			
—	D13-0032-03	Sprocket	
—	E23-0047-04	Terminal x 17	
—	J25-1147-03	PC board	

PARTS LIST

HET UNIT (X50-1250-00)

Ref. No.	Parts No.	Description	Re- marks
CAPACITOR			
C1, 2	CC45SL1H050D	Ceramic 5pF ±0.5pF	
C4, 5	CK45F1H103Z	Ceramic 0.01μF +80%, -20%	
C7	CK45D1H102M	Ceramic 0.001μF ±20%	
C8	CC45SL1H330J	Ceramic 33pF ±5%	
C9	CC45TH1H390J	Ceramic 39pF ±5%	
C10	CK45F1H103Z	Ceramic 0.01μF +80%, -20%	
C11	CC45SL1H221J	Ceramic 220pF ±5%	
C12	CK45F1H103Z	Ceramic 0.01μF +80%, -20%	
C13	CC45CH1H150J	Ceramic 15pF ±5%	
C14	CK45F1H103Z	Ceramic 0.01μF +80%, -20%	
C15	C90-0231-05	Ceramic 0.5pF +80%, -20%	
C16	CC45CH1H120J	Ceramic 12pF ±5%	
C17	CC45SL1H150J	Ceramic 15pF ±5%	
C18,19	CK45D1H102M	Ceramic 0.001μF ±20%	
C20	CK45F1H103Z	Ceramic 0.01μF +80%, -20%	
RESISTOR			
R1, 2	PD14CY2E473J	Carbon 47kΩ ±5% 1/4W	
R4	PD14CY2E101J	Carbon 100Ω ±5% 1/4W	
R5	PD14CY2E470J	Carbon 47Ω ±5% 1/4W	
R6	PD14CY2E101J	Carbon 100Ω ±5% 1/4W	
R8	PD14CY2E102J	Carbon 1kΩ ±5% 1/4W	
R9	PD14CY2E273J	Carbon 27kΩ ±5% 1/4W	
R10	PD14CY2E682J	Carbon 6.8kΩ ±5% 1/4W	
R11	PD14CY2E102J	Carbon 1kΩ ±5% 1/4W	
R12	PD14CY2E101J	Carbon 100Ω ±5% 1/4W	
R13	PD14CY2E103J	Carbon 10kΩ ±5% 1/4W	
R14	PD14CY2E104J	Carbon 100kΩ ±5% 1/4W	
R15	PD14CY2E100J	Carbon 10Ω ±5% 1/4W	
R16	PD14CY2E101J	Carbon 100Ω ±5% 1/4W	
R17	PD14CY2E220J	Carbon 220Ω ±5% 1/4W	
R18	PD14CY2E473J	Carbon 47kΩ ±5% 1/4W	
SEMICONDUCTOR			
Q1	V03-0104-05	Transistor 2SC535 (A)	
Q2, 3	V03-0079-05	Transistor 2SC460 (B)	
D1, 2	V11-0551-05	Diode 1N60	
COIL / X'tal / TRIMMER			
T1	L32-0182-05	Oscillation coil	
T2, 3	L31-0267-05	Tuning coil	
L1, 2	L40-1511-03	Ferri-inductor (150μH)	
L4	L40-1511-03	Ferri-inductor (150μH)	
L5, 6	L40-1011-03	Ferri-inductor (100μH)	
X1	L77-0401-05	Crystal oscillator (38.666 MHz)	
X2	L77-0409-05	Crystal oscillator (39 MHz)	
TC1, 2	C05-0029-15	Ceramic trimmer	
MISCELLANEOUS			
-	E18-0201-05	Crystal socket	
-	E23-0047-05	Terminal x 5	
-	J25-1148-09	PC board	

CONTROL UNIT (X53-1040-00)

Ref. No.	Parts No.	Description	Re- marks
CAPACITOR			
C1 ~ 3	CK45D1H102M	Ceramic 0.001μF ±20%	
C4	CC45SL2H220J	Ceramic 22pF ±5%	
C5	CC45SL2H010C	Ceramic 1pF ±0.25pF	
C6	CE04W1H4R7(RL)	Electrolytic 4.7μF 50WV	
C7	CE04W1HR47(RL)	Electrolytic 0.47μF 50W	
C8 ~ 10	CK45D1H102M	Ceramic 0.001μF ±20%	
C11	CC45SL2H050C	Ceramic 5pF ±0.25pF	
C12,13	CC45SL2H010C	Ceramic 1pF ±0.25pF	
C14	CK45D1H102M	Ceramic 0.001μF ±20%	
RESISTOR			
R1	PD14CY2E103J	Carbon 10kΩ ±5% 1/4W	
R2	PD14CY2E104J	Carbon 100kΩ ±5% 1/4W	
R3	PD14CY2E472J	Carbon 4.7kΩ ±5% 1/4W	
R4	PD14CY2E222J	Carbon 2.2kΩ ±5% 1/4W	
R5	PD14CY2E823J	Carbon 82kΩ ±5% 1/4W	
R6	PD14CY2E153J	Carbon 15kΩ ±5% 1/4W	
SEMICONDUCTOR			
Q1	V03-0123-05	Transistor 2SC733 (Y)	
D1 ~ 5	V11-0051-05	Diode 1N60	
COIL			
L1	L40-1011-03	Ferri-inductor (100μH)	
L3	L33-0025-05	Choke coil (1μH)	
L4	L40-1011-03	Ferri-inductor (100μH)	
L5	L39-0052-05	Detecting coil	
POTENTIOMETER			
VR1	R12-5014-05	Volume 100kΩ	
VR2	R12-4016-05	Volume 50kΩ	
VR3	R12-0042-05	Volume 500Ω	
MISCELLANEOUS			
-	E23-0047-04	Terminal x 10	
-	J25-1149-14	PC board	

FINAL UNIT (X56-1150-00)

Ref. No.	Parts No.	Description	Re- marks
CAPACITOR			
C1	CC45SL2H070D	Ceramic 7pF ±0.5pF	
C2	CC45SL2H100J	Ceramic 10pF ±5%	
C3	CK45D1H102M	Ceramic 0.001μF ±20%	
C4	CK18E2H102P	Ceramic 0.001μF +100%, -0%	
C5, 6	C90-0117-05	Ceramic 0.001μF +100%, -0%	
C7	CK45D1H102M	Ceramic 0.001μF ±20%	
C8	CC45SL2H470J	Ceramic 47pF ±5%	
C9	CC45SL2H330J	Ceramic 33pF ±5%	
C10,11	CK45D1H102M	Ceramic 0.001μF ±20%	
C12	CC45SL2H270J	Ceramic 27pF ±5%	
C13	CC45SL2H070D	Ceramic 7pF ±0.5pF	
C14	C90-0117-05	Ceramic 0.001μF ±0.5pF	
C15	CK18E2H102P	Ceramic 0.001μF +100%, -0%	

TROUBLESHOOTING

RECEIVING SECTION

SYMPTOM	CAUSE	REMEDY
1. No power supply is available.	<ol style="list-style-type: none"> 1) Blown fuse 2) Defective power switch 3) Disconnection near plug 	<ul style="list-style-type: none"> ○ Replace ○ Check and replace ○ Check power cord
2. Blown fuse	<ol style="list-style-type: none"> 1) Defective rectifier diode U05B of Rectifier AVR unit (X43-1150-00) 2) 15 Volt B circuit shorted to chassis 	<ul style="list-style-type: none"> ○ Replace ○ Check and rewire
3. Too low sensitivity	<ol style="list-style-type: none"> 1) Disconnection or short circuit of connecting wire 2) Defective FET Q6, Q7 of RF unit (X44-1120-00) 3) Poor adjustment of tuning circuit of RF unit (X44-1120-00) 4) Defective D6 (WZ061) of RF unit (X44-1120-00) 5) Poor adjustment of Helical resonator 6) Poor contact of relay 	<ul style="list-style-type: none"> ○ Check and replace ○ Replace ○ Readjust T6, T7, T8, T9 ○ Replace ○ Readjust ○ Replace
4. No receiver noise	<ol style="list-style-type: none"> 1) Poor adjustment of oscillating coil of HET oscillator unit (X50-1250-00) 2) Defective diode switch of HET oscillator unit (X50-1250-00) 3) Poor contact of band-switch of HET oscillator unit (X50-1250-00) 4) Disconnection of output coaxial cable 5) Disconnection of antenna circuit or IF output coaxial cable 	<ul style="list-style-type: none"> ○ Readjust ○ Replace ○ Check contact ○ Check contact ○ Check and rewire

TRANSMITTING SECTION

SYMPTOM	CAUSE	REMEDY
1. No output	<ol style="list-style-type: none"> 1) Defective Q1, Q2 of Final unit (X56-1150-00) 2) Defective Q1, Q2, Q3, Q4, Q5 of RF unit (X44-1120-00) 3) Poor adjustment of oscillating coil of HET oscillator unit (X50-1250-00) 4) Disconnecting of input or output coaxial cable 5) Poor adjustment of VR3 of Control unit (X53-1040-00) 6) Poor contact of relay 7) Disconnecting or short circuit of connecting cord 	<ul style="list-style-type: none"> ○ Replace ○ Replace ○ Readjust ○ Check contact and rewire ○ Readjust ○ Replace ○ Check and replace
2. Low output	<ol style="list-style-type: none"> 1) Poor adjustment of trimmer capacitor of Final unit (X56-1150-00) 2) Poor tuning of tuning circuit of RF unit (X44-1120-00) 3) Poor adjustment of T2, T3 of HET oscillator unit (X50-1250-00) 4) Poor adjustment of VR2, VR3 of control unit (X53-1040-00) 5) Defective Q1, Q3, D5, D6 of Rectifier AVR unit (X43-1150-00) 	<ul style="list-style-type: none"> ○ Readjust ○ Readjust ○ Readjust ○ Readjust ○ Replace
3. Too high or too low deflection of RF meter	<ol style="list-style-type: none"> 1) Poor adjustment of VR1 of Control unit (X53-1040-00) 	<ul style="list-style-type: none"> ○ Readjust
4. No deflection of RF meter	<ol style="list-style-type: none"> 1) Defective D1, D5 of Control unit (X53-1040-00) 	<ul style="list-style-type: none"> ○ Replace
5. Too high deflection of ALC meter due to undesirable high power output	<ol style="list-style-type: none"> 1) Poor adjustment of VR2 of Control unit (X53-1040-00) 	<ul style="list-style-type: none"> ○ Readjust
6. Too low deflection of ALC meter due to extremely low output	<ol style="list-style-type: none"> 1) Disconnection of connecting cable 	<ul style="list-style-type: none"> ○ Check conduction and refer to 2. Low output
7. Stand-by function is inoperative	<ol style="list-style-type: none"> 1) Relay does not work 2) Relay keeps working position unnecessarily, although switch is turned off. 	<ul style="list-style-type: none"> ○ Check and replace Q5 of Rectifier AVR unit (X43-1150-00), connecting cable and connector. ○ Check and replace Q5 of Rectifier AVR unit (X43-1150-00)

ADJUSTMENTS

Adjustments of TV-502 should be performed with TS-520 connected as shown in Fig. 7.

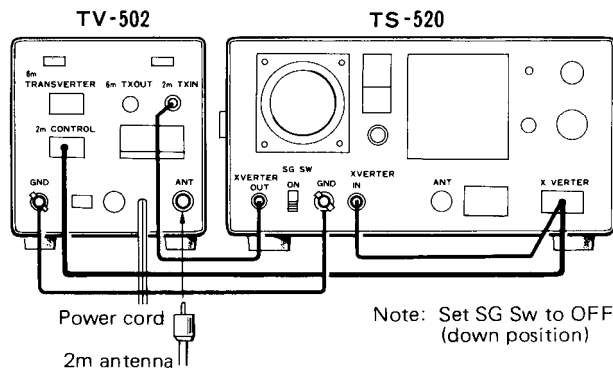

Fig. 7 Connection

RECEIVING SECTION

Fig. 8 shows the level diagram of reception.

NOTE 1: As shown in Fig. 8, the SSG signal of 145.0 MHz 0dB is fed from the ANT terminal and the AF VR is adjusted for the audio output of 0.63 V/8Ω. When the AF VR is properly adjusted for the specified audio level, the SSG signal level indicated at each section should be obtained.

NOTE 2: Measurement of SSG output should be made through a ceramic capacitor of 0.01μF (50 WV).

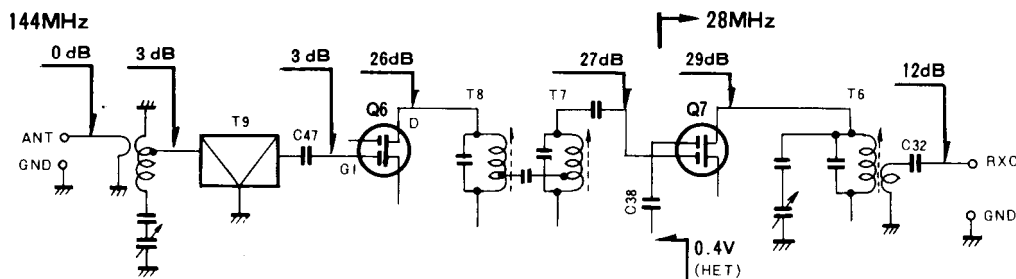

Fig. 8 Level Diagram of Reception

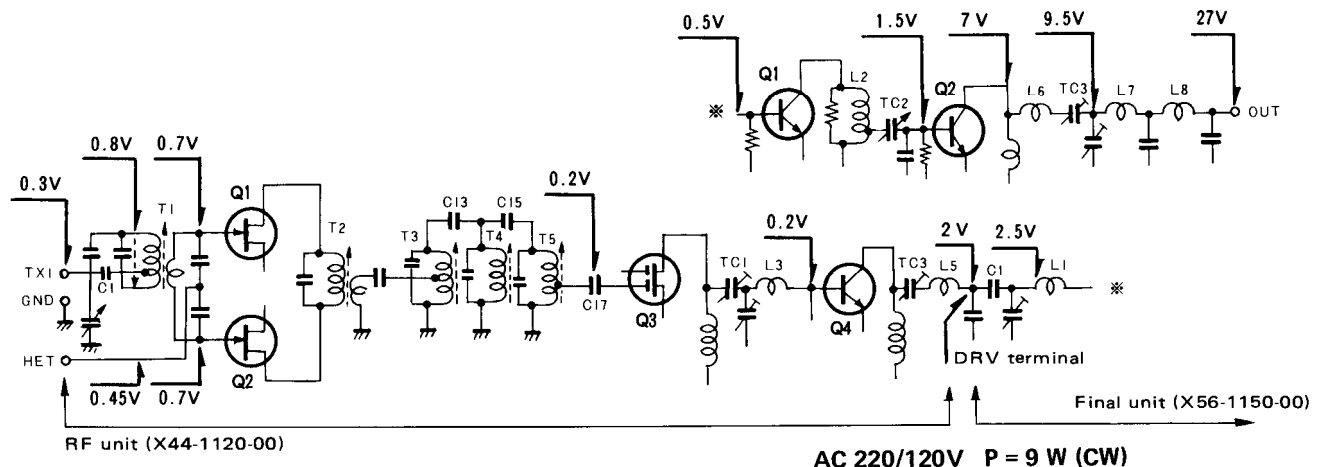

Fig. 9 Level Diagram of Transmission

1. Rectifier/AVR Unit (X53-1150-00)

- (1) Test equipment
 - 1) Voltmeter (tester)
- (2) Adjustments (Fig. 10)
 - 1) 15 V Setting

With the power switch turned to ON, connect a DC voltmeter to the terminal (14) on the AVR unit.

Adjust VR1 for 15 V on the voltmeter.

- 2) 9 V Setting

Connect the DC voltmeter to the terminal (9) on the AVR unit. Adjust VR2 for 9 V on the voltmeter

2. Heterodyne Oscillator Unit (X50-1250-00)

- (1) Test equipment
 - 1) RF VTVM (f: 150 MHz or higher)
 - 2) Frequency Counter (f: 150 MHz or higher)
- (2) Adjustment (Fig. 10)
 - 1) Adjustment of Oscillating Level

Connect the RF VTVM to the OUT terminal on the heterodyne unit. Turn the core of T1 so that the output is set at 1dB down position from the peak point. This adjustment should be performed using an insulated screwdriver. Next, adjust T2 and T3 for maximum reading on VTVM.

Repeat the above adjustment two or three times.

ADJUSTMENTS

- 2) Check of Vacant Channel (X2) Output
Set the BAND switch to "145 MHz" to check that the crystal is oscillating. After checking, remove the crystal and set the BAND switch back to "144 MHz".
- 3) Adjustment of Heterodyne Frequency
Disconnect the VTVM and connect the frequency counter instead. Adjust TC1 for 116 MHz of frequency. Then set TC2 in the mechanical center position.

TV-502

Front Panel:	
POWER switch	ON
BAND switch	144
IN TUNE knob	Center position
PRESELECTOR knob	Center position
Rear Panel:	
AC-DC selector switch	AC
2m ONLY-6m CONNECT selector switch	2m ONLY

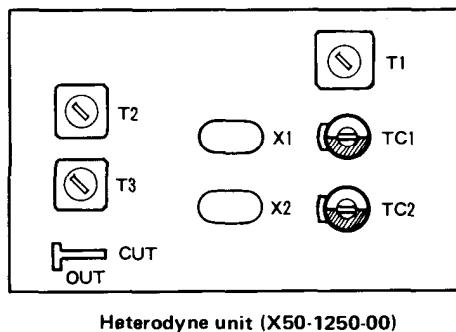
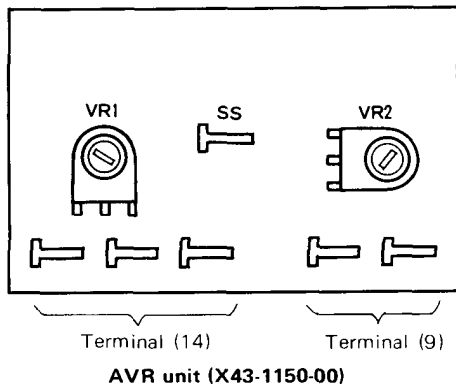

Fig. 10

3. RF Unit (X44-1120-00)

- (1) Test equipment
 - 1) SSG (f: 144 ~ 148 MHz, modulation not required)
 - 2) Oscilloscope
 - 3) AF VTVM
- (2) Adjustment
Before adjustments, set the switches and knobs on TV-502 as follows:

1) 144.5 MHz Sensitivity Adjustment

Set the band switch on TS-520 to "28.5 MHz". Then set the VFO dial to "0" and the mode switch to "USB". Apply the signal of 144.5 MHz 60dB from SSG to the antenna terminal on TV-502. Adjust the VFO knob and DRIVE knob for maximum reading on the S meter. Then adjust T6 in the RF unit until the S meter of TS-520 indicates maximum deflection.

2) 145 MHz Sensitivity Adjustment

Set the VFO dial to "0" (29 MHz) and apply the 145 MHz signal of SSG. Adjust the DRIVE knob on TS-520 for maximum sensitivity. Next, adjust the IF TUNE knob on TV-502 for maximum reading on the S meter. Also, adjust T7 and T8 in the RF unit until maximum sensitivity is obtained. The adjustment should be repeated two or three times. Note that the signal level of SSG should be lowered properly according to the increase of the sensitivity. Then obtain a maximum reading on the S meter by adjusting the air-core coil of the helical filter.

NOTE: The PRESELECTOR knob should set in its center position.

3) 144 MHz Sensitivity Adjustment

Set the band switch on TS-520 to "28 MHz". Then set the VFO dial to "0" and apply the 144 MHz signal from SSG. Adjust TS-520 for maximum sensitivity. To obtain maximum reading on the S meter, turn the IF TUNE knob on TV-502. The maximum sensitivity can be obtained by adjusting the 3 cores of T9 from the rear of the printed circuit board.

ADJUSTMENTS

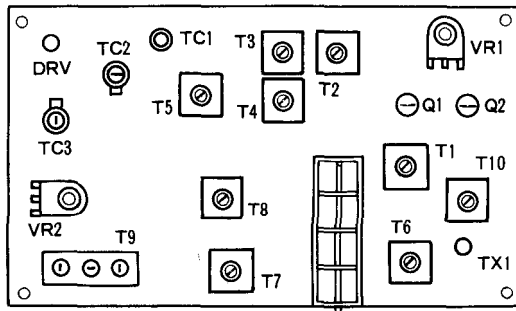

Fig. 11 RF Unit (X44-1120-00)

TRANSMITTING SECTION:

Fig. 9 shows the transmission level diagram.

NOTE: The levels indicated in Fig. 9 were measured with RF VTVM having input capacitance of less than 3pF in the condition CW output of 9 W during AC operation

1. Preparation for Adjustment

- (1) Test equipment
 - 1) DC power supply (12-16 V adjustable, 2A min.)
 - 2) RF VTVM
 - 3) 50Ω terminated power meter
 - 4) DC voltmeter (tester)
 - 5) SSG
- (2) Adjustment

Before making adjustments, the switches and knobs on TV-502 and TS-520, and the semi-fixed resistors in the RF unit and control unit, should be set as follows:

TV-502

FRONT PANEL	
POWER Switch	ON
BAND Switch	144
IF TUNE Knob	Center position (or maximum receiving sensitivity)
PRESELECTOR Knob	Center position (or maximum receiving sensitivity)
REAR PANEL	
AC-DC Selector Switch	DC
2m ONLY-6m CONNECT Selector Switch	2m ONLY

TS-520

FRONT PANEL	
MODE Switch	CW
H.SW Switch	ON
CAR Knob	Center position
REAR PANEL	
SG Switch	OFF

RF unit (X44-1120-00)
VR2 Maximum clockwise
Control unit (X53-1040-00)
VR2 Maximum clockwise

The adjustment of transmitter section should preferably be made with a DC power stabilizer for observing the current consumption (power supply voltage of 12 V).

2. Adjustment of RF Unit (X44-1120-00)

- (1) Set the band switch on TS-520 to "28.5" and the VFO dial to "500". Connect the RF VTVM to the DRV terminal on the RF unit and set the standby switch on TS-520 to "SEND".
- (2) Adjust the DRIVE knob on TS-520 and also adjust T1 ~ 5, TC1 and TC2 in the RF unit of TV-520 so that a maximum reading is obtained on the RF VTVM.

3. Power Adjustment

- (1) Maintaining power supply voltage of 12 V, disconnect the RF VTVM. Adjust T3 in the RF unit and TC1 and TC2 in the final unit for maximum current (Fig. 14).
- (2) With TC3 and TC4 in the final unit set to the positions shown in Fig. 12(A), fine adjust so that a maximum power is obtained.

NOTE: Care should be taken in adjustment because TC3 and TC4 are also tuned in the positions shown in Fig. 12(B).

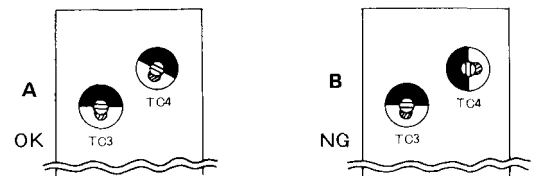

Fig. 12

- (3) Next, set the power voltage to 15 V. Fine adjust TC3 in the RF unit and TC1 and TC2 in the final unit for maximum current.
- (4) Readjust TC3 and TC4 in the final unit to obtain maximum power. This adjustment should be repeated two or three times.

NOTE: TC4 should be set in such a position that the current begins to decrease while the output power remains unchanged.

- (5) Set the band switch on TS-520 to "28" and the VFO dial to "500". The IF TUNE knob on TV-502 should be in its center position.
- (6) Adjust the DRIVE knob on TS-520 until the ALC meter causes maximum deflection and then adjust T1 in the RF unit for maximum current.

ADJUSTMENTS

- (7) Under the above condition, set the AC-DC selector switch on the rear panel to "AC". Then, adjust VR2 of the control unit until the output power reaches 9 W (ALC adjustment) (Fig. 15).
- (8) Turn VR1 of the control unit so that the RF meter indicates the point "8" (RF meter adjustment). Then, set the AC-DC selector switch back to "DC".

4. Readjustment of RF Unit

- (1) Set the band switch on TS-520 to "28.5" with the VFO dial remaining in "500" position.
- (2) Turn the DRIVE knob on TS-520 and the IF TUNE knob on TV-502 until the ALC meter on TS-520 causes maximum deflection.
- (3) Fine adjust T2 ~ T5, TC1 and TC2 in the RF unit of TV-502 for maximum reading on the ALC meter. This adjustment should be repeated several times.

NOTE: This adjustment must be made carefully because it largely relates to the spurious radiation.

5. Protection Adjustment

- (1) Connect the "minus" lead of a voltmeter to the -6 terminal of the control unit (X53-1040-00) and the "plus" lead to the PRO terminal. Adjust VR3 in the control unit for minimum reading on the voltmeter.
- (2) Disconnect the leads of the voltmeter, set VR2 in the RF unit to the center position and remove the cord of the power meter (antenna open circuited). Adjust VR2 in the RF unit so that the current flow reaches 1A.

NOTE: This adjustment should be performed quickly.

6. Trap Adjustment

- (1) Set the band selector switch to "145". Remove the pin cord from the 2m TX IN terminal and connect SSG to feed 148 MHz 100 dB signal.
- (2) Connect RF VTVM to the gate of Q1 in the RF unit and adjust T1 for minimum reading on VTVM.

NOTE 1: The series trap consisting of T10 and C2 is used to remove the fourfold harmonics ($37 \text{ MHz} \times 4 = 148 \text{ MHz}$) of the frequency of the 28 MHz heterodyne oscillator in TS-520. It protects TS-520 against the near-by spurious radiation.

NOTE 2: If expected effect cannot be attained by adjusting the trap, readjust the heterodyne oscillator coil in TS-520.

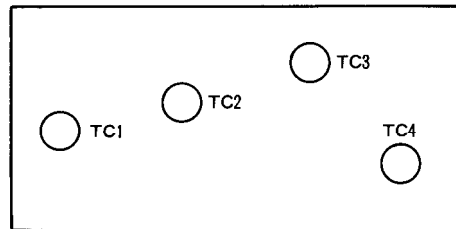

Fig. 14 Final unit (X56-1150-00)

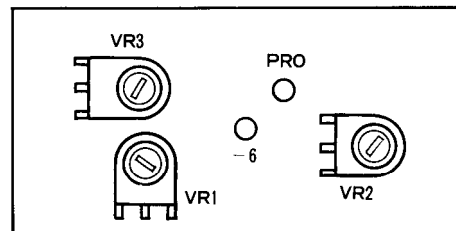

Fig. 15 Control unit (X53-1040-00)

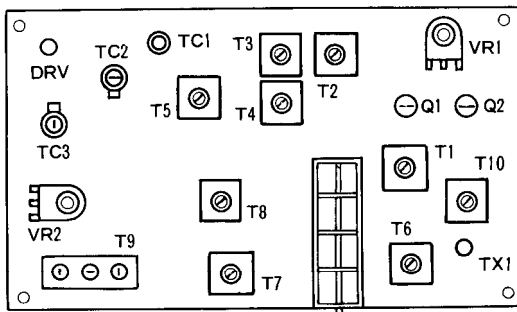

Fig. 13 RF unit (X44-1120-00)

ADJUSTMENTS/REFERENCE

Replacement of Transistors in Final Unit:

The final unit uses two transistors. One is Q1 (2SC1169) in the driver circuit and the other is Q2 (2SC1242A) in the power amplifier circuit at the final stage. To replace these transistors, remove the case and follow the procedure shown in the illustration (see Fig. 16).

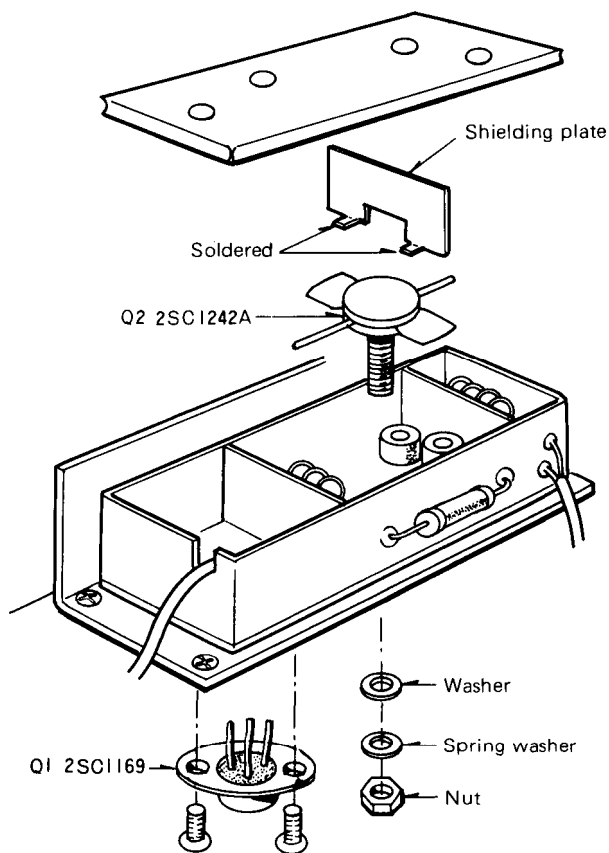

Fig. 16 Replacement of Final Unit Transistors

*REFERENCE

1. Connection of TV-502 to TS-520 and Precaution for Operation

(1) Fig. 17 shows the method of connecting TV-502 to TS-520.

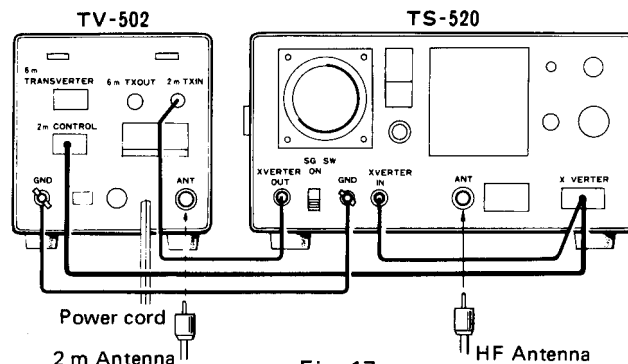

Fig. 17

If the circuit of TS-520 has already been changed as described previously, it is possible to start 2m operation with the SG switch on TS-520 and the HF antenna left as they are. For HF operation, simply set the power switch of TV-502 to OFF.

If the modified TS-520 is to be used alone, be sure to insert the 12P shorting plug supplied with TV-502.

(2) For 2m operation, if TV-502 is connected to TS-520 whose circuit is not changed, make certain that the SG switch is set to OFF and the HF antenna is removed. For HF operation under such a condition, be sure to disconnect the pin cord plug from the X VERTER IN terminal on TS-520 (For decrease of receiving sensitivity might happen.)

2. Method of Reducing 2m Band Near-by Suprious radiation (TS-520)

When the transverter is connected for 2m operation, the HF unit (TS-520) may sometimes become a cause of suprious radiation (near-by suprious during transmission). While TS-520 is designed to fully meet with the requirements of HF band, it has been done in the circuit starting with No. 05 production lot that only the 28 MHz band is improved to less than -50 dB to satisfy the requirement (less than -60 dB) of the 2m band specified in the ELECTRIC WAVE LAW.

The suprious radiation in 2m band can be further reduced by making readjustments as follows:

NOTE: Refer to the Technical Service Information (Bo-Ho-205) for the above improvement in TS-520.

REFERENCE

Adjusting Method:

- (1) Adjust each knob on TS-520 and TV-502 for maximum power in 144.8 MHz (28.8 MHz for TS-520) MODE CW.
- (2) Obtain maximum reading on the ALC meter by adjusting the semi-fixed resistor VR11 on the lug in the IF unit of TS-520.
- (3) Receive a signal around 144.585 MHz using another receiver and readjust VR11 (TS-520) for minimum reading on the S meter (another receiver). In the level where the S meter causes no deflection, readjustment should also be made for minimum AF output (TS-520).

3. Method of Improving Near-by Suprious radiation and second harmonics (TV-502)

- (1) Final unit
Position of TC4 (for improving second harmonics)

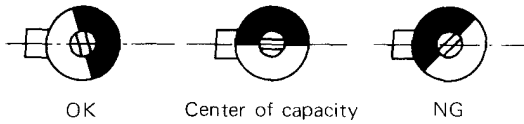

Turn to increase capacity from center position.

Turn to decrease capacity from center position.

- (2) RF unit
1) Position of TC3 (for improving of suprious of 116 MHz local oscillator)
Set TC3 to the point C1 on the following figure.

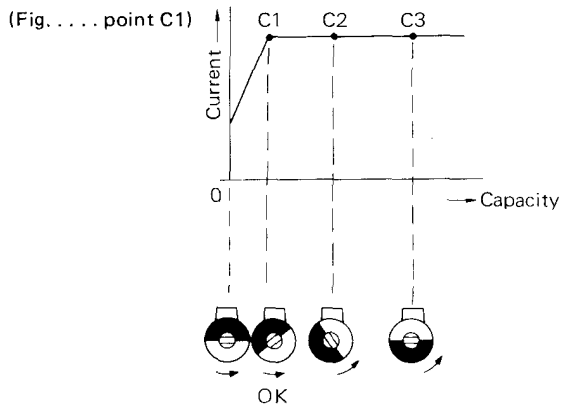

- 2) Core position of T2 ~ T5 (for improving near-by suprious)
Set T4 so that the core juts out about 1 ~ 2 mm as figure a. Be caution that the core position of T3, T5 varies according to that of T4.

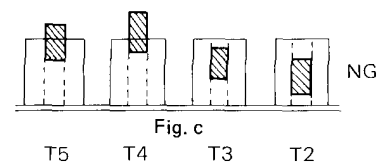
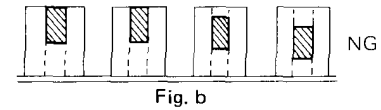
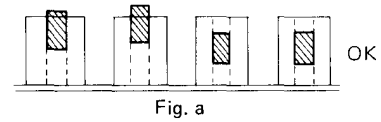

A product of
TRIO-KENWOOD CORPORATION
6-17, 3-chome, Aobadai, Meguro-ku, Tokyo 153, Japan

TRIO-KENWOOD COMMUNICATIONS, INC.
1111, West Walnut Street, Compton, California, 90220, U.S.A.
TRIO-KENWOOD COMMUNICATIONS, GmbH
D 6374 Steinbach TS, Industriestrasse 8A, West Germany
TRIO-KENWOOD (AUSTRALIA) PTY. LTD.
30 Whiting Street, Artarmon, Sydney N.S.W. Australia 2064

Free Manuals Download Website

<http://myh66.com>

<http://usermanuals.us>

<http://www.somanuals.com>

<http://www.4manuals.cc>

<http://www.manual-lib.com>

<http://www.404manual.com>

<http://www.luxmanual.com>

<http://aubethermostatmanual.com>

Golf course search by state

<http://golfingnear.com>

Email search by domain

<http://emailbydomain.com>

Auto manuals search

<http://auto.somanuals.com>

TV manuals search

<http://tv.somanuals.com>