

# KENWOOD

AV CONTROL CENTER

**C-V351**

**C-V301**

---

## INSTRUCTION MANUAL

KENWOOD CORPORATION

**This manual contains instructions for two models. Model availability and features (functions) may differ depending on country and sales area.**

B60-4349-00 (EN)

# Before applying power

 **Caution : Read this page carefully to ensure safe operation.**

C-V351/C-V301 (EN)

**2** Units are designed for operation as follows.

Europe and U.K. .... AC 230 V only

## For the United Kingdom

### Factory fitted moulded mains plug

1. The mains plug contains a fuse. For replacement, use only a 13-Amp ASTA-approved (BS1362) fuse.
2. The fuse cover must be refitted when replacing the fuse in the moulded plug.
3. Do not cut off the mains plug from this equipment. If the plug fitted is not suitable for the power points in your home or the cable is too short to reach a power point, then obtain an appropriate safety approved extension lead or adapter, or consult your dealer.  
If nonetheless the mains plug is cut off, remove the fuse and dispose of the plug immediately, to avoid a possible shock hazard by inadvertent connection to the mains supply.

IMPORTANT: The wires in the mains lead are coloured in accordance with the following code:

Blue: Neutral

Brown: Live

Do not connect those leads to the earth terminal of a three-pin plug.

## Safety precautions

**WARNING :** TO PREVENT FIRE OR ELECTRIC SHOCK, DO NOT EXPOSE THIS APPLIANCE TO RAIN OR MOISTURE.



**CAUTION**  
RISK OF ELECTRIC SHOCK  
DO NOT OPEN



CAUTION: TO REDUCE THE RISK OF ELECTRIC SHOCK, DO NOT REMOVE COVER (OR BACK). NO USER-SERVICEABLE PARTS INSIDE, REFER SERVICING TO QUALIFIED SERVICE PERSONNEL.



THE LIGHTNING FLASH WITH ARROWHEAD SYMBOL, WITHIN AN EQUILATERAL TRIANGLE, IS INTENDED TO ALERT THE USER TO THE PRESENCE OF UNINSULATED "DANGEROUS VOLTAGE" WITHIN THE PRODUCT'S ENCLOSURE THAT MAY BE OF SUFFICIENT MAGNITUDE TO CONSTITUTE A RISK OF ELECTRIC SHOCK TO PERSONS.



THE EXCLAMATION POINT WITHIN AN EQUILATERAL TRIANGLE IS INTENDED TO ALERT THE USER TO THE PRESENCE OF IMPORTANT OPERATING AND MAINTENANCE (SERVICING) INSTRUCTIONS IN THE LITERATURE ACCOMPANYING THE APPLIANCE.

## Unpacking

Unpack the unit carefully and make sure that all accessories are put aside so they will not be lost. Examine the unit for any possibility of shipping damage. If your unit is damaged or fails to operate, notify your dealer immediately. If your unit was shipped to you directly, notify the shipping company without delay. Only the consignee (the person or company receiving the unit) can file a claim against the carrier for shipping damage. We recommend that you retain the original carton and packing materials for use should you transport or ship the unit in the future.

## Accessories

FM indoor antenna (1)

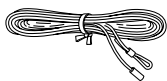

AM loop antenna (1)

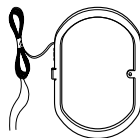

Graphical Remote Control unit (1)  
(C-V351)



(Optional with the C-V301)

Remote control unit (1)  
(C-V301)



Loop antenna stand (1)

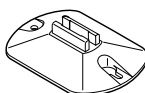

Batteries(R6/AA) (4)  
(C-V351)

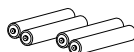



Batteries(R6/AA) (2)  
(C-V301)



# Contents

**Caution : Read the pages marked  carefully to ensure safe operation.**

3

<b>Before applying power</b> .....	<b>2</b>
 Safety precautions .....	2
Unpacking .....	2
<b>Contents</b> .....	<b>3</b>
<b>Special features</b> .....	<b>4</b>
<b>System connection</b> .....	<b>5</b>
Connection of audio components (CD player, MD recorder, cassette deck, power amplifier) .....	5
Connection of video components (LD player, VCR, DVD) .....	6
About the system control connections .....	7
Connection of flat-cable connector .....	7
Connection of antenna .....	8
<b>Controls and indicators</b> .....	<b>9</b>
<b>Setup of the Graphical Remote Control (GRC) unit (For C-V351)</b> .....	<b>11</b>
Controls and indicators (Optional with the C-V301) .....	11
Setting up the GRC according to your AV CONTROL CENTER (Model Type Setup) .....	12
Setting up the GRC according to the option components (Set Up) .....	13
Setting up the GRC according to other components (Set Up) .....	15
<b>Remote control of components from the GRC (For C-V351)</b> .....	<b>16</b>
Controlling the AV CONTROL CENTER .....	16
Controlling the components connected through system control cords .....	17
<b>Remote control with the "RC" unit (For C-V301)</b> .....	<b>20</b>
Names and functions of the keys .....	20
<b>Convenient functions</b> .....	<b>21</b>
One-touch operation and easy operation features .....	21
<b>Playing music</b> .....	<b>22</b>
<b>Sound adjustment functions</b> .....	<b>23</b>
<b>Recording</b> .....	<b>25</b>
<b>Broadcast reception</b> .....	<b>26</b>
Receiving broadcast station .....	26
<b>RDS (Radio Data System)</b> .....	<b>27</b>
Functions of RDS .....	27
DISPLAY key .....	27
Storing RDS stations automatically in preset memory (AUTO MEMORY) .....	28
Receiving a preset RDS station .....	28
Storing radio stations manually in preset memory .....	29
Receiving a preset station .....	29
Receiving all preset stations in order (P. CALL) .....	29
Searching for a desired program type (PTY search) .....	30
Reserving reception of desired kind of programme in advance (EON reservation) .....	32
To cancel EON reservation .....	33
<b>Ambience effects</b> .....	<b>34</b>
Sound modes .....	34
Setup for surround play .....	36
Surround play .....	38
Setup for surround play (while listening to music) .....	39
Setup of the surround effect parameters (DSP) .....	43
<b>Clock adjustment</b> .....	<b>45</b>
Displaying the Time .....	45
<b>Timer operation</b> .....	<b>46</b>
Timer programming .....	46
Activating the timer .....	48
Sleep timer .....	49
<b>Set up code chart</b> .....	<b>50</b>
VCR Set up codes .....	50
TV Set up codes .....	51
TV Set up codes .....	52
LD Set up codes .....	52
Satellite Set up codes .....	53
Cable Set up codes .....	53
<b>In case of difficulty</b> .....	<b>54</b>
<b> Specifications</b> .....	<b>56</b>

## Special features

### True home theater sound

#### Dolby Pro Logic & Dolby 3 Stereo

This surround system reproduces theater-like surround sound from video software marked **DOLBY DIGITAL**. The PRO LOGIC mode uses the built-in adaptive matrix circuit to steer the Left, Center, Right and Surround channel audio signals. The 3 STEREO mode will redirect the surround signal to the front left and right speakers when only the front and center speakers are used.

#### New DSP surround modes

The DSP (Digital Signal Processor) used for this AV CONTROL CENTER incorporates a variety of high quality adjustable sound fields, like "ARENA", "JAZZ CLUB" and "STADIUM", to add the "presence" associated with an arena, jazz club or stadium (etc.) to the original signal. It is compatible with almost any kind of program source.

### Graphical Remote Control unit "GRC"(Optional with the C-V301)

The GRC unit incorporates a large-screen LCD which displays key icons and parameters. The LCD also shows information on the operating modes of the main unit.

To improve the operability, frequently used icons are located in the higher hierarchy in the LCD display and icons which are associated between each other are shown on the same screen.

The GRC unit is a multi-function remote control unit which can be programmed to control AV components from other manufacturers than KENWOOD.

In the case of C-V301, It is able to use Graphical Remote Control (GRC-151/Option).

### RDS (Radio Data System) tuner

This AV CONTROL CENTER is equipped with a RDS tuner that provides several convenient tuning functions: AUTO MEMORY, to automatically preset up to 40 RDS stations broadcasting different programs; station name display, to show you the name of the current broadcast station; and PTY search to let you tune stations by program type.

### ONE TOUCH OPERATION

Simply pressing the play key of the CD player or cassette deck turns the system on and starts playback.

## How to use this manual

In this manual, the operating procedures are described on the left half of each page and the supplementary explanation, display information and other notes on each step are described on the right half.

(Example of instructions in this manual)

#### Operating procedure steps (Left half)

#### Supplementary explanation (Right half)

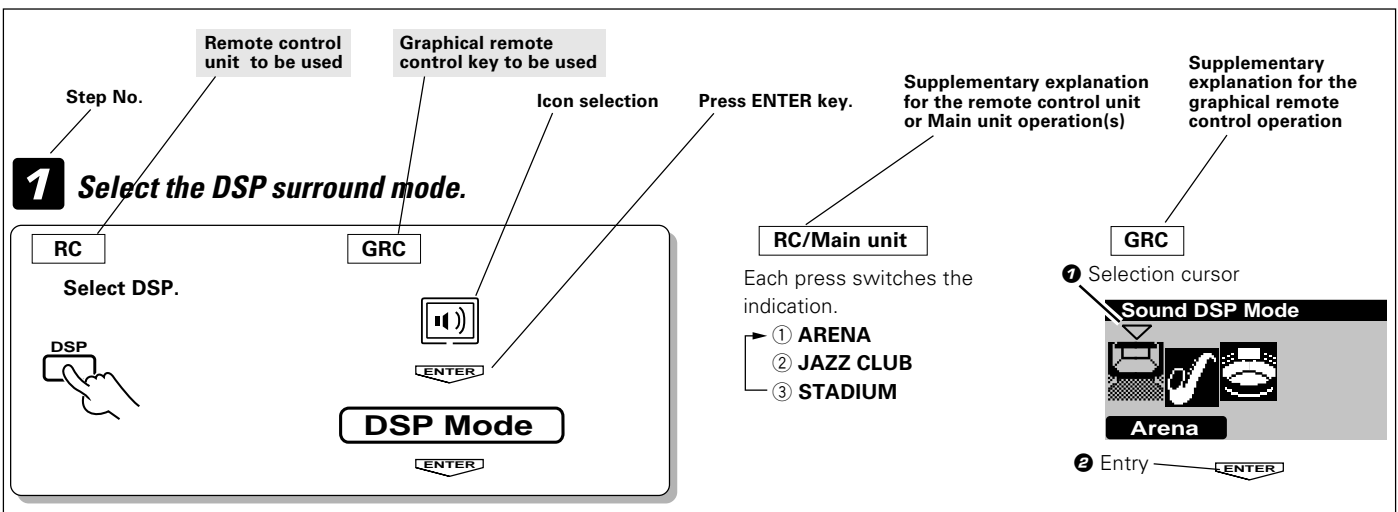

## Connection of audio components (CD player, MD recorder, cassette deck, power amplifier)

Make connection as shown below.

When connecting the related system components, refer also to the instruction manuals of the related components.

⚠ Do not plug in the power lead until all connections are completed.

### Malfunction of microcomputer

If operation is not possible or erroneous display appears even though all connections have been made properly, reset the microcomputer referring to "In case of difficulty".

→ 54

Analog disc turntable (with built-in equalizer amp)

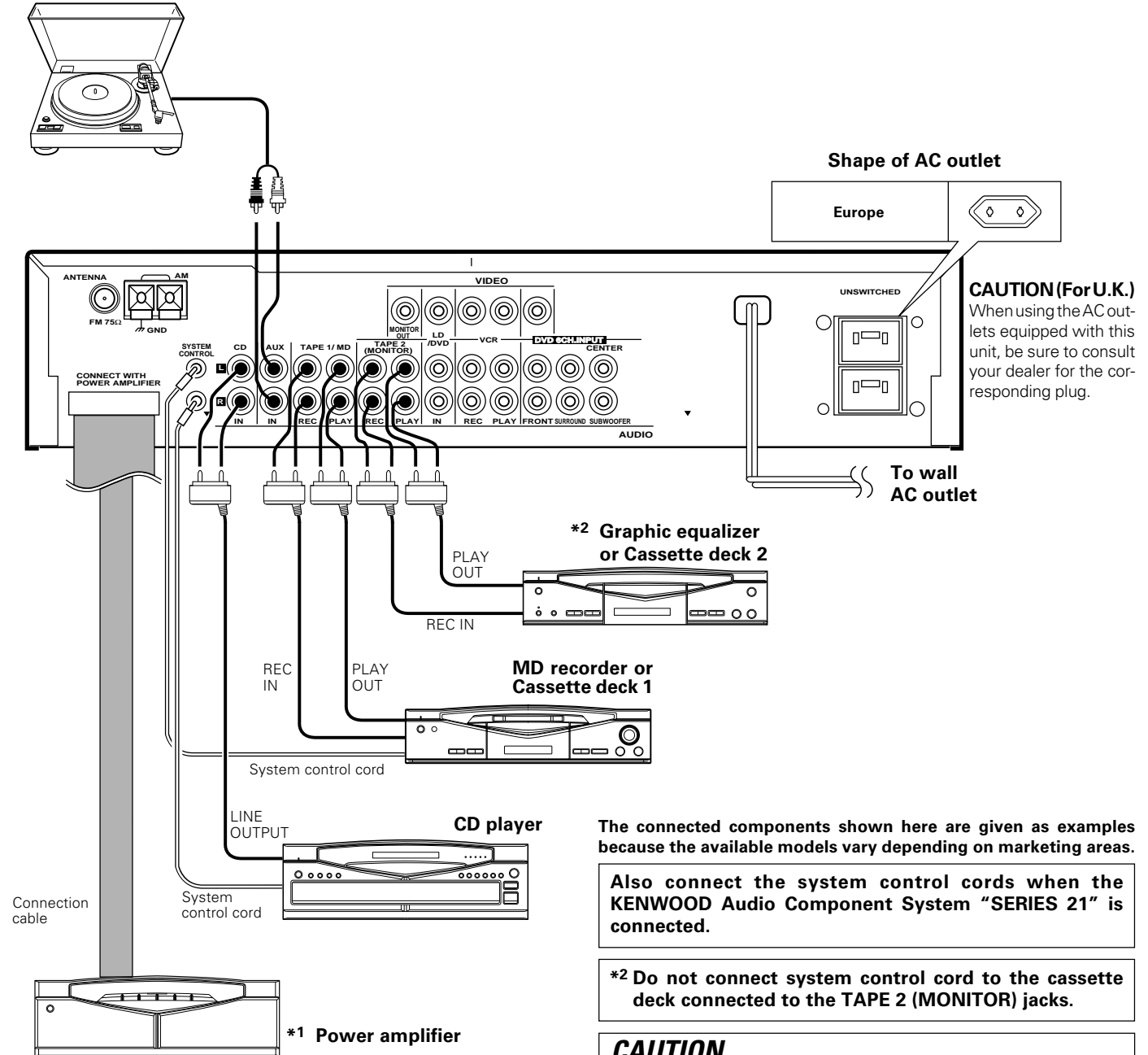

\*1 For the connection and operation procedures of the power amplifier and speakers, refer to the instruction manual of the power amplifier (M-A300 or M-A100).

The connected components shown here are given as examples because the available models vary depending on marketing areas.

Also connect the system control cords when the KENWOOD Audio Component System "SERIES 21" is connected.

\*2 Do not connect system control cord to the cassette deck connected to the TAPE 2 (MONITOR) jacks.

### CAUTION

Be sure to adhere followings. Or proper ventilation will be blocked causing damage or fire hazard.

- Install the R-SE7 on the top of the system.
- Do not place any objects impairing heat radiation onto the top of unit.
- Leave a space around the unit (from the largest outside dimension including projection) equal or greater than, shown below.

Top panel : 50 cm  
Side panel : 10 cm  
Back panel : 10 cm

# Connection of video components (LD player, VCR, DVD)

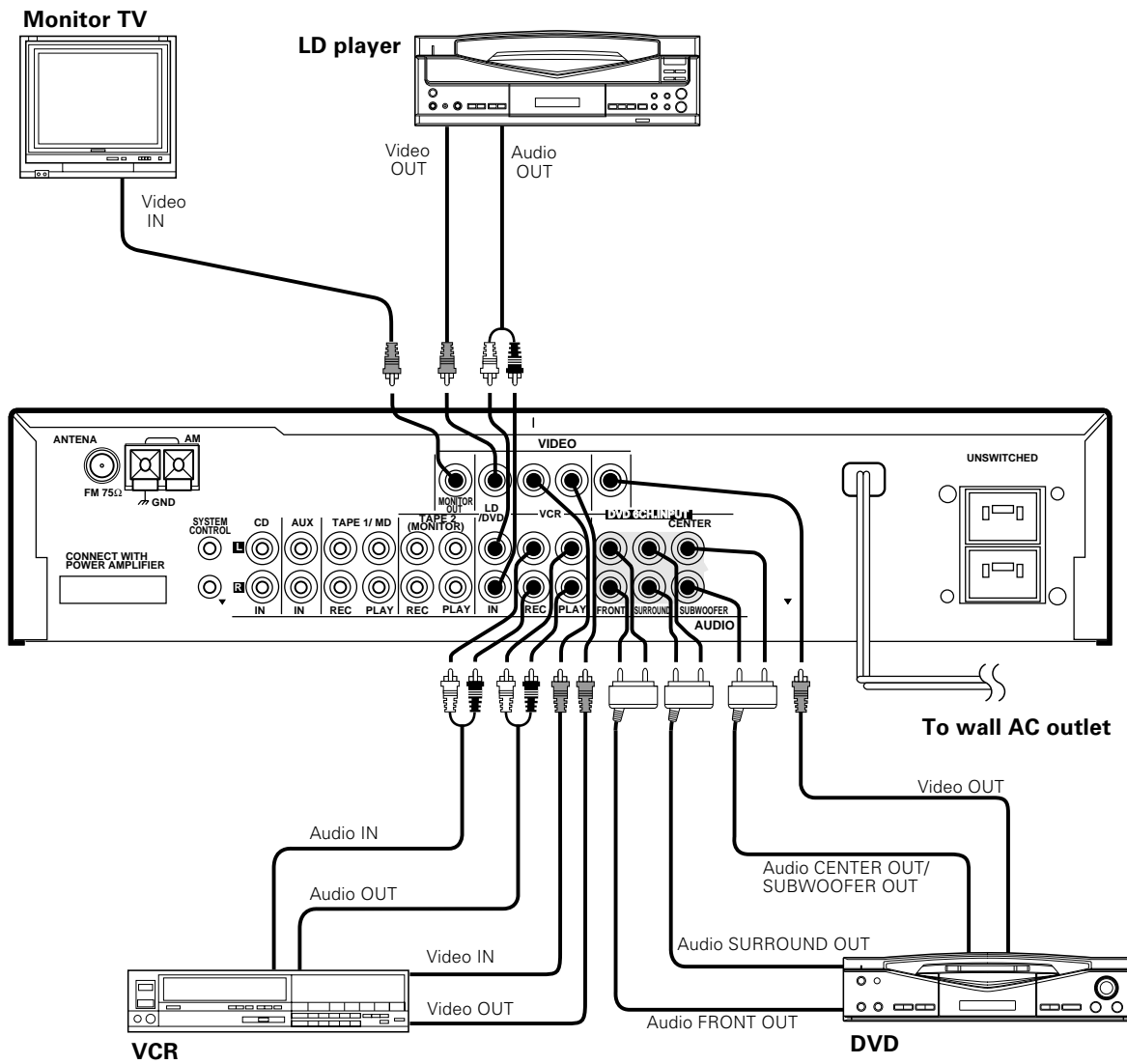

The connected components are given as examples because the available models vary depending on marketing areas.

# About the system control connections

When this unit is connected to KENWOOD audio component system "SERIES 21", also connect them through the system control cords to allow system-control operations between components.

## Connection example

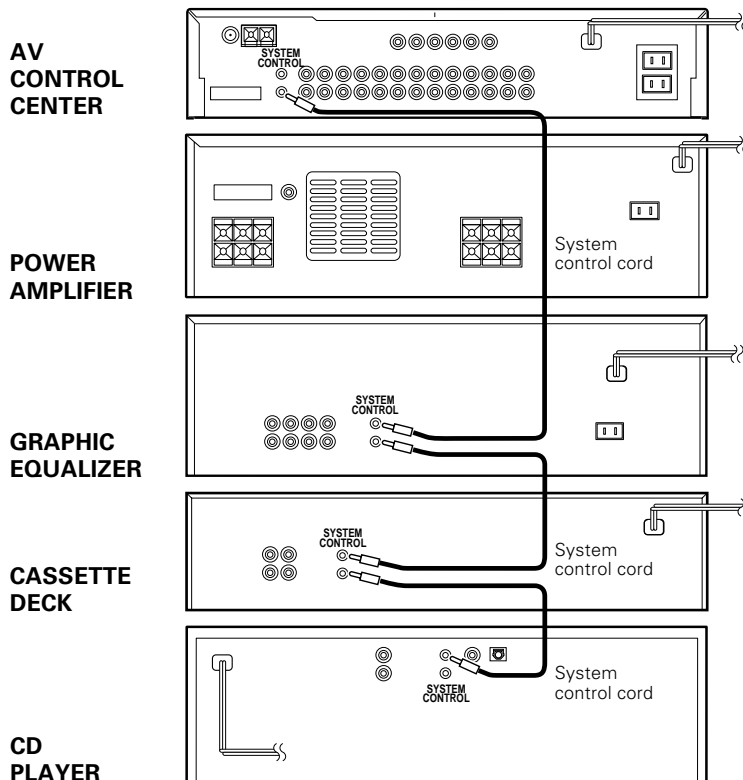

The SERIES 21 components which can be system-connected with this unit include the LD player, MD recorder, and DVD player.



1. Do not connect the SERIES 21 components to other system components using system control cords.
2. Do not connect system control cords to any components other than those specified by KENWOOD. It may cause a malfunction and damage your equipment.
3. Be sure the system control plugs are inserted all the way in to the system control terminals.

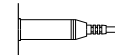

## About the system control operations

(Available operations when SERIES 21 components are connected through system control cords)

### Remote Control

Lets you operate source components with the system remote supplied with this unit.

### Automatic Operation

When you start playback from a source component, the input selector on this unit switches to that component automatically. (Except TAPE 2)

### Synchronized Recording

Lets you synchronize recording with the start of playback when recording from CD or LD.

## Connection of flat-cable connector

### Inserting the connector

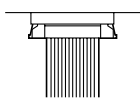

Push in the connector straight into the socket until it clicks to indicate the locking.

### Removing the connector

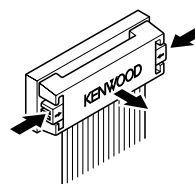

Push and hold the two ends of the connector, and pull it straight outward.



1. Connect all cords firmly. If connections are loose, there could be loss of sound or noise produced.
2. When plugging and unplugging connection cords, be sure to first remove the power cord from the AC outlet. Plugging / unplugging connection cords without removal of the power cord can cause malfunctions or damage to the unit.
3. Do not connect up a power source which is larger than that indicated on the socket at the rear of the unit.
4. If the system control cords or audio cords are not connected properly, the remote control or automatic operation between system components will not work properly.

8 **Connection of antenna****Connection method to each antenna terminal**

① Push lever.

② Insert cord.

③ Return lever.

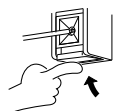
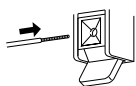
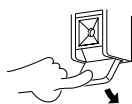
**AM loop antenna connection**

The supplied antenna is for indoor use. Place it as far as possible from the main system, TV set, speaker cords, and power cord, and set it to a direction which provides the best reception.

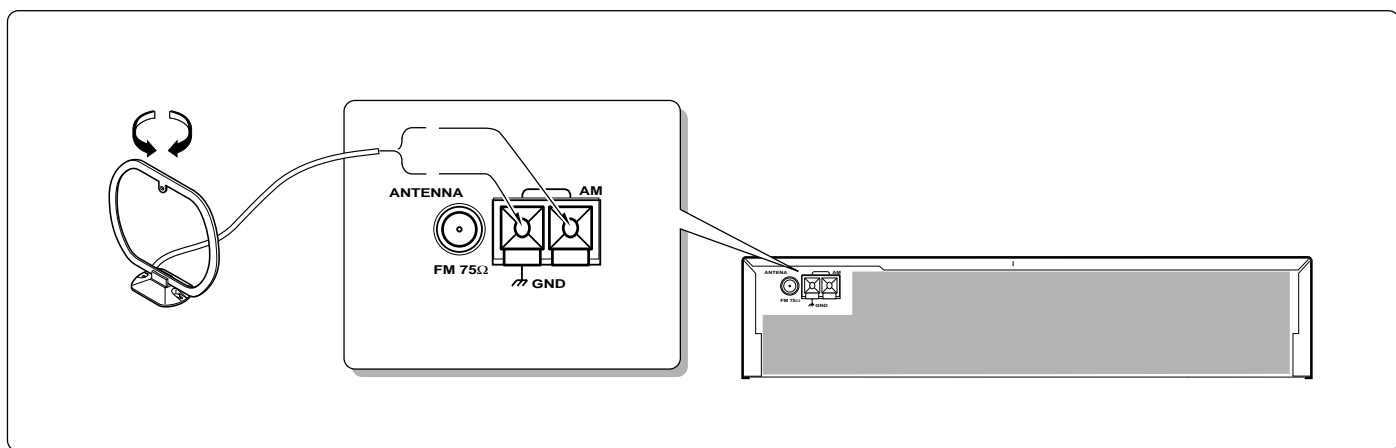
**FM indoor antenna connection**

The accessory antenna is for temporary indoor use only. For stable signal reception we recommend using an outdoor antenna. Remove the indoor antenna if you connect one outdoors.

**FM outdoor antenna connection**

Lead the 75 Ω coaxial cable connected to the FM outdoor antenna into the room and connect it to the FM 75 Ω terminal.

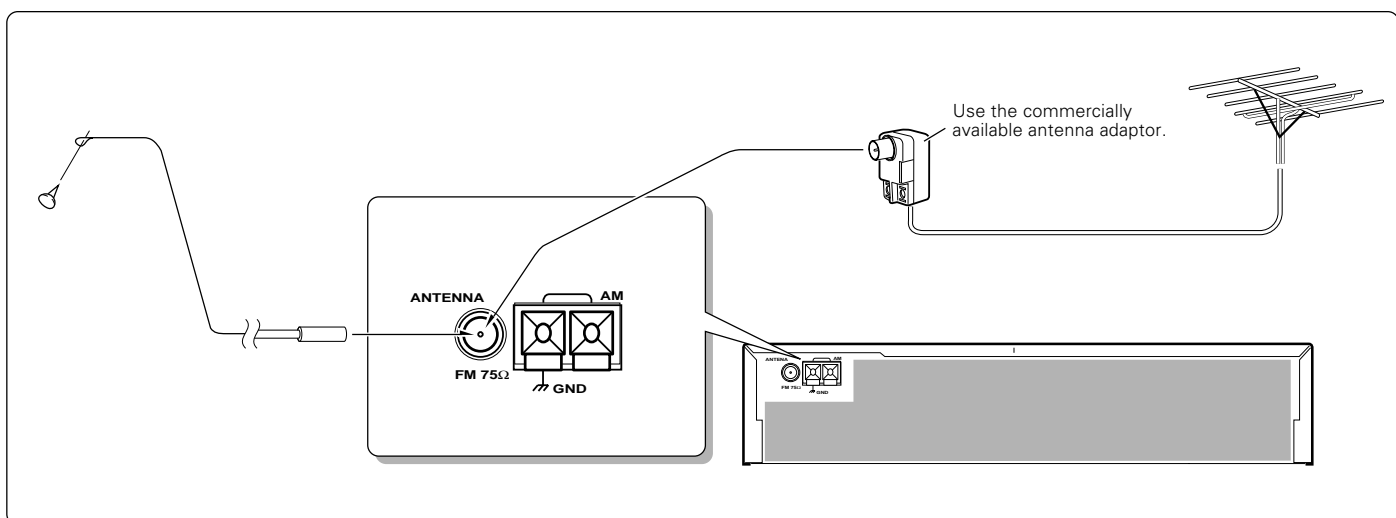



# Controls and indicators

C-V351/C-V301 (EN)

9

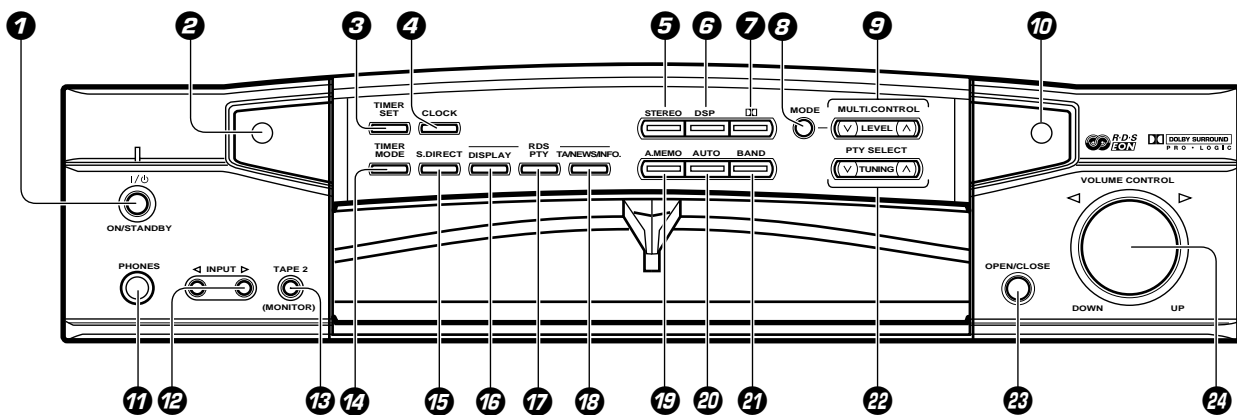
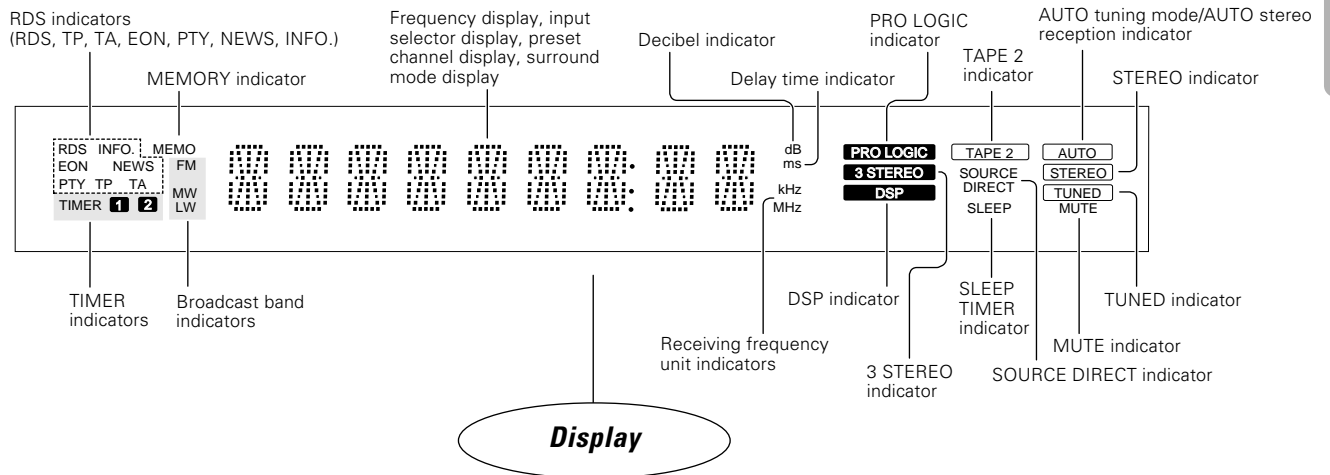

The keys which have the same names as the controls on the remote control unit provide the same functions as them.

- 1 ON/STANDBY key**  
Press to switch between ON and STANDBY.
- 2 Remote sensor**
- 3 TIMER SET key**  
Press to set the timer function.
- 4 CLOCK key**  
Press to set the clock.
- 5 STEREO key**
- 6 DSP key**
- 7 DOLBY key**
- 8 MODE key**  
Press to switch various setting modes.
- 9 MULTI.CONTROL key**  
Press to select various setting modes.
- 10 GRC transmitter**  
Outputs the signals transmitted to the Graphical Remote Control.
- 11 PHONES jack**  
For use in headphones listening.
- 12 INPUT SELECTOR key**  
Press to select the input.
- 13 TAPE 2 (MONITOR) key**  
For use in monitoring of recording, etc.
- 14 TIMER MODE key**  
Press to switch the timer modes.
- 15 S.DIRECT key**  
Press to switch the Source Direct function which allows to reproduce the source with a better quality.
- 16 RDS DISPLAY key**  
Press to switch the RDS display.
- 17 RDS PTY key**  
For use during reception of RDS broadcasting.
- 18 RDS TA/NEWS/INFO. key**  
For use during reception of RDS broadcasting.
- 19 A.MEMO key**  
Press when using the auto memory function.
- 20 AUTO key**  
Press to select the tuning mode. The auto tuning or manual tuning mode can be selected. The input selection display of a source can be switched to another by pressing and holding the **AUTO** key for more than 2 seconds.
- 21 BAND key**  
Press to switch the broadcasting band.
- 22 TUNING key (∇, ▲)**  
Press to select the radio station to be received. These keys are also used in the clock adjustment and timer operations.
- 23 OPEN/CLOSE key**
- 24 VOLUME CONTROL knob**

## Standby mode

While the standby indicator of the unit is lit, a small amount of current is flowing into the unit's internal circuitry to back up the memory. This condition is referred to as the standby mode of the unit. While the unit is in the standby mode, it can be turned ON from the remote control unit. With this unit, standby mode is indicated by means of the display panel. The system is in standby mode while the clock display is shown.

## Opening/closing the door

OPEN/CLOSE



When opening or closing the door, be careful not to catch your finger in the door. Otherwise there is a risk of injury.

## Changing the input selection display (AUTO key)

**\*1: To change the TAPE 1 display to MD display**

- ① Select "TAPE 1" with the INPUT SELECTOR .
- ② Press and hold the AUTO key for more than 2 seconds, until "MD" is displayed.

Each press switches the indication.

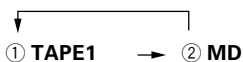

**\*2: To change the LD display to the DVD display**

- ① Select "LD" with the INPUT SELECTOR .
- ② Press and hold the AUTO key for more than 2 seconds, until "DVD" is displayed.

Each press switches the indication.



To make the system control operation, the input selection display should be switched according to the actually connected components.

About the system control connections



## Switching the display mode (DISPLAY key)

Use the following procedure to change the display mode.

Press the DISPLAY key (RC and GRC only).  
Select "Display" from "Main Menu 2" when using the GRC.

Each press switches the indication.



- The time display is displayed for only 5 seconds, after which the INPUT SELECTOR display appears automatically.
- The display of ② is not shown during SOURCE DIRECT and 6ch INPUT operations.
- With the C-V301, the display does not change while the INPUT SELECTOR is set for the LD input.

# Setup of the Graphical Remote Control (GRC) unit (For C-V351)

C-V351/C-V301 (EN)

## Controls and indicators

(Optional with the C-V301)

11

The Graphical Remote Control (GRC) unit provided with the AV CONTROL CENTER can also control KENWOOD cassette decks, CD player, DVD player and LD player which are connected to it through system control cords. For details of the controllable functions, refer to the instruction manuals of these components.

Model:GRC-151  
Infrared system



Perform "Model Type Setup" of the GRC before using it. The following menu screen appears immediately after the batteries have been loaded for the first time.

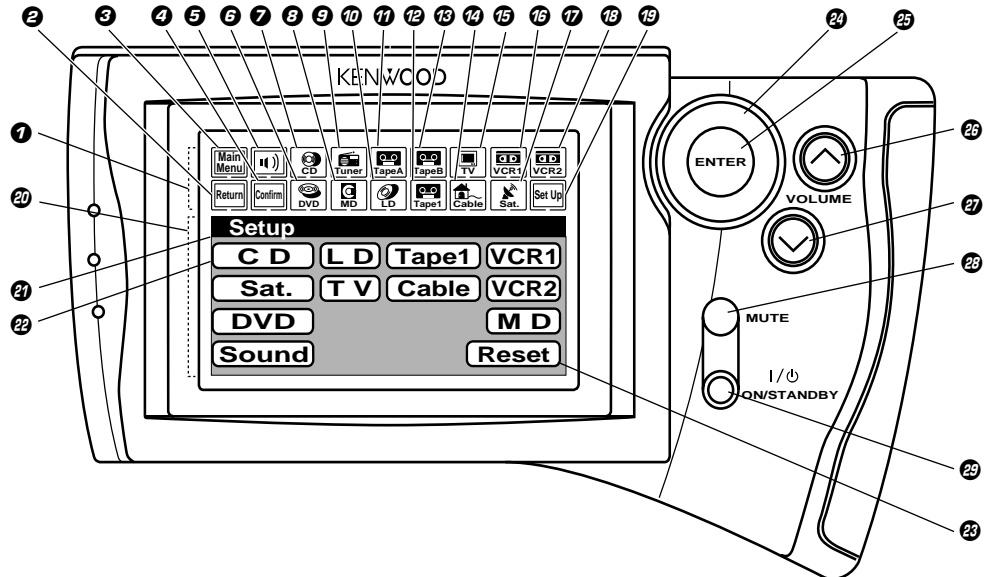
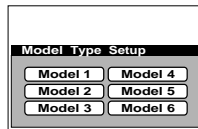

### Segment screen

#### ① Segment screen

This area displays the fixed icons.

#### ② Return icon

Select to return to the previous display.

#### ③ Main Menu icon

Select to change the input source or select Main Menu 2.

#### ④ Confirm icon

Select to confirm a setting, etc.

#### ⑤ Sound icon

Select to control the sound-related functions.

#### ⑥ DVD icon

Select to control the DVD player.

#### ⑦ CD icon

Select to control the CD player.

#### ⑧ MD icon

Select to control the MD recorder.

#### ⑨ Tuner icon

Select to control the tuner.

#### ⑩ LD icon

Select to control the LD player.

#### ⑪ Tape A icon

Select to control cassette deck A.

#### ⑫ Tape 1 icon

Select to control cassette deck 1.

#### ⑬ Tape B icon

Select to control cassette deck B.

#### ⑭ Cable TV icon

Select to control the cable TV.

#### ⑮ TV icon

Select to control the TV.

#### ⑯ VCR 1 icon

Select to control VCR 1.

#### ⑰ Satellite Tuner icon

Select to control the satellite tuner.

#### ⑱ VCR 2 icon

Select to control VCR 2.

#### ⑲ Set Up icon

Select to make setup operations.

- The input source can be selected using icon ③.
- Icons ⑤ to ⑱ are used to select the component to be controlled.

The displayed icons are variable depending on the "Model Type Setup" for matching the specifications with the AV CONTROL CENTER which uses the GRC unit and "Setup" for matching the specifications with connected source component.

### Menu screen

#### ⑳ Menu screen

This area displays the control key icons and level information.

#### ㉑ Mode display

The above illustration indicates the Setup mode.

#### ㉒ CD icon

Select to set up the CD player.

#### ㉓ Reset icon

Select to return to the "Model Type Setup" menu screen.

### Operation keys

#### ㉔ Joystick key

For use in selecting icons. The joystick moves in 8 directions.

#### ㉕ ENTER key

Press to enter a selection.

#### ㉖ VOLUME (UP) control key

Press to increase the volume level.

#### ㉗ VOLUME (DOWN) control key

Press to decrease the volume level.

#### ㉘ MUTE key

Press to mute sound temporarily.

#### ㉙ I/⏻ (ON/STANDBY) key

Press to switch the AV CONTROL CENTER and the components connected to it through system control cords between ON and STANDBY.

## Approximate operating range

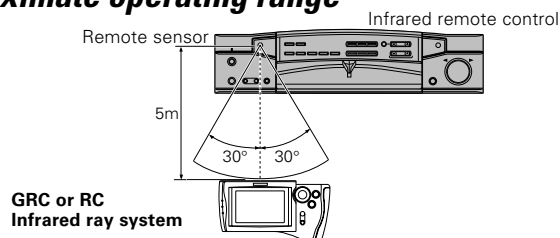

1. The supplied batteries are intended for use in operation check. Therefore, their lives may be shorter than ordinary batteries.
2. When the remote-controllable distance gets shorter than before, replace all four batteries with new ones.
3. Malfunction may occur if direct sunlight or the light of a high-frequency lighting fluorescent lamp enters the remote sensor. In such a case, change the system installation position to prevent the malfunction.
4. The GRC display may show erroneous information when the GRC unit is operated from outside the specified range.

# Setting up the GRC according to your AV CONTROL CENTER (Model Type Setup)

Perform the following procedure after inserting batteries for the first time and every time after changing them.

## Preparation

- Press the I/⏻ (ON/STANDBY) key of the main unit to the ON mode.

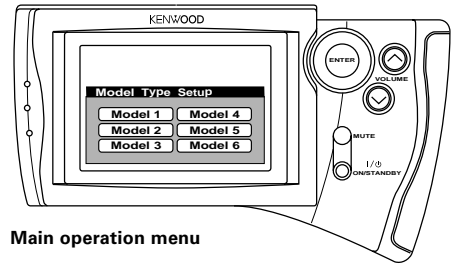

Main operation menu

## Model Type Setup (GRC setup procedure)

### 1 Loading batteries

➊ Remove the cover.

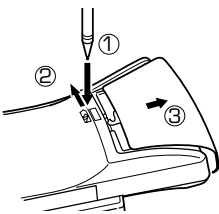

➋ Insert batteries.

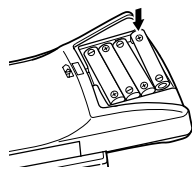

➌ Close the cover.

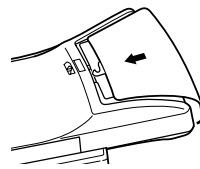

### Caution in battery replacement

- Insert four AA-size (R6/AA) batteries as indicated by the polarity marking.
- To maintain the memory of the settings you made before, complete the battery replacement operation within 30 seconds.
- The procedure on the left should also be performed when resetting the GRC (as a measure against its malfunction). However, in this case, wait for about five minutes after removing the batteries and before re-inserting them.

### 2 Check the display.

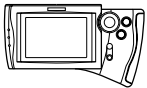

The "Model Type Setup" screen appears.

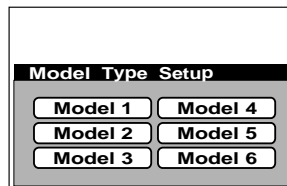

### 3 Select "Model 2."

Move the cursor.

It can be moved in 8 directions depending on how you press the joystick key.

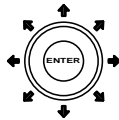

The icon on which the cursor is moved blinks in reverse video.

AV CONTROL CENTER Model

GRC

"Model Type Setup" icon

C-V301 ..... Model 2

C-V351 ..... Model 2

### 4 Enter the selection.

Press the ENTER key.



### To reset GRC setting

➊ Select Set Up.



➋ Press the ENTER key.



➌ Select Reset.



➍ Press the ENTER key.



➎ Perform the setup procedure from step "➋ Check the display".

- The above operation clears all of the previously made settings and resets the unit to the initial condition.

# Setting up the GRC according to the option components (Set Up)

The following procedures prepare the GRC for operating the components connected through system control cords. Make sure that these components are connected through system control cords.



- If you proceed to the following "Set Up" operations immediately after steps 1 to 2 of "Model Type Setup (GRC setup procedure)" on page 12, start operation with step 3 "Select the CD icon" in the "Set Up CD" procedure.

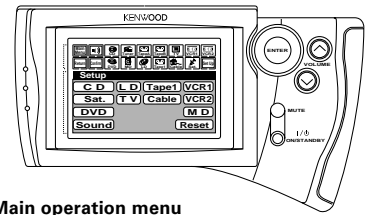

Main operation menu

## Set Up CD

Setup of GRC according to the CD player in use

## Set Up Tape 1

Setup of GRC according to the cassette deck in use

## Set Up LD

Setup of GRC according to the LD player in use

- 1 Select the "Set Up" icon.



- 2 Press the "ENTER" key to enter the selection.



- 3 Select the "CD" icon.



- 4 Press the "ENTER" key to enter the selection.



- 5 Select the "Single" icon.



- Select "Single", "Dual", "Carrousel" or "Changer" according to the connected CD player type.

- 6 Press the "ENTER" key to enter the selection.



- 7 Select the "Main Menu" icon.



- 8 Press the "ENTER" key to enter the selection.



- 1 Select the "Set Up" icon.



- 2 Press the "ENTER" key to enter the selection.



- 3 Select the "Tape 1" icon.



- 4 Press the "ENTER" key to enter the selection.



- 5 Select the "Dual" icon.



- Select "Dual" or "Single" according to the connected cassette deck type.

- 6 Press the "ENTER" key to enter the selection.



- 7 Select the "Main Menu" icon.



- 8 Press the "ENTER" key to enter the selection.



- 1 Select the "Set Up" icon.



- 2 Press the "ENTER" key to enter the selection.



- 3 Select the "LD" icon.



- 4 Press the "ENTER" key to enter the selection.



- 5 Select the "System Control" icon.



- Select "System Control" or "IR" according to the connected LD player type.

- 6 Press the "ENTER" key to enter the selection.



- 7 Select the "Main Menu" icon.



- 8 Press the "ENTER" key to enter the selection.



- Icon appears at the moment the setup has completed.

- Icons / or icon appear at the moment the setup has completed.

- Icon appears at the moment the setup has completed.



In the operations of the GRC (Graphical Remote Control unit), proceed to each step within 10 seconds after the previous step. The display disappears in 10 seconds.



To resume GRC display, move the Joy-stick key in any directions.

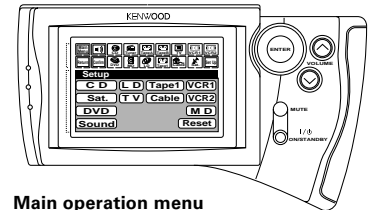

Main operation menu

## Set Up MD

Setup of GRC according to the MD recorder in use

- 1 Select the "Set Up" icon.



- 2 Press the "ENTER" key to enter the selection.



- 3 Select the "MD" icon.



- 4 Press the "ENTER" key to enter the selection.



- 5 Select the "System Control" icon.



- Select "System Control" or "IR" according to the connected MD recorder type.

- 6 Press the "ENTER" key to enter the selection.



- 7 Select the "Main Menu" icon.



- 8 Press the "ENTER" key to enter the selection.



- Icon appears at the moment the setup has completed.

## Set Up DVD

Setup of GRC according to the DVD player in use

- 1 Select the "Set Up" icon.



- 2 Press the "ENTER" key to enter the selection.



- 3 Select the "DVD" icon.



- 4 Press the "ENTER" key to enter the selection.



- 5 Select the "Main Menu" icon.



- 6 Press the "ENTER" key to enter the selection.



- Icons appear at the moment the setup has completed.

## Setting up the GRC according to other components (Set Up)

The GRC can also be used to remote control other components which are not connected through system control cords. To control another component, it is required to register the setup code corresponding to it beforehand. 

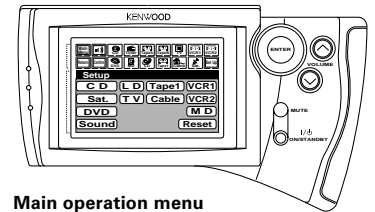

Main operation menu

## Registering setup codes for VCR 1

**1** Find the setup code of the component to be registered by referring to the Setup code chart in this manual.

**2** Enter the setup code.

① Select the "Set Up" icon.



② Enter the selection  
(by pressing the "ENTER" key).



③ Select the "VCR 1" icon.



④ Enter the selection  
(by pressing the "ENTER" key).



⑤ Enter the setup code.

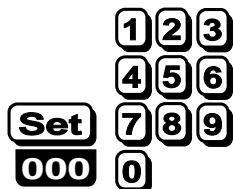

⑥ Select the "Set" icon.



⑦ Enter the selection  
(by pressing the "ENTER" key).



### Check the operation of the component.

- ① Display the operation screen of the component to be checked.
- ② Turn on the component from the GRC and confirm the actual component.
- If there is more than one setup code, input each code to see which one turns the power on. That will be the correct code for your component.



Although each setup code is designed to work with a number of different models, certain codes may not work with some models. (Also, certain codes may only operate some of the functions available on a given model.) With some models, be sure to keep the ENTER key pressed for a while.

Use the numeric keys as shown below.

Entry examples:

431 ..... 4 ENTER 3 ENTER 1 ENTER

400 ..... 4 ENTER 0 ENTER 0 ENTER

- When a code which is not shown in the setup code chart is entered, the entered code disappears automatically.

## Registering setup codes of other components

The procedure of steps **1** and **2-1** to **7** of "Registering setup code for VCR 1" also allows to register the components listed below to remote control them from the GRC.

**Registering setup code for VCR 2**

**Registering setup code for TV**

**Registering setup code for CABLE**

**Registering setup code for SATELLITE**

**Registering setup code for LD player (IR)**

# Remote control of components from the GRC (For C-V351)

C-V351/C-V301 (EN)

16

## Controlling the AV CONTROL CENTER

The operations required to remote control the AV CONTROL CENTER includes the INPUT SELECTOR selection, display mode selection, stereo selection and so on.

The following procedures show how to remote control the basic operations of the GRC.

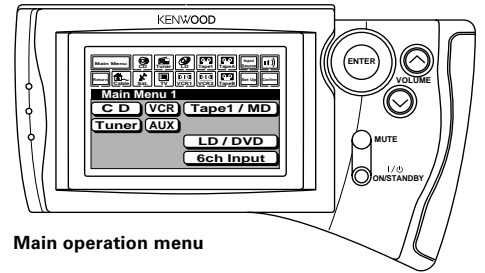

Main operation menu

## Operation examples

### Switching the INPUT SELECTOR (Selecting the CD input)

- 1 Select the "Main Menu" icon in the fixed segment screen by operating the joystick.



- 2 Press the "ENTER" key to enter the selection.



- 3 Select the "CD" icon with the joystick.

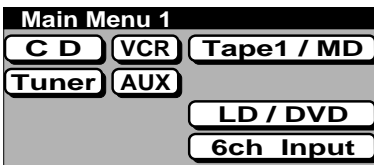

- 4 Press the "ENTER" key to enter the selection.



- 5 The input source is switched to "CD".

- Other input than CD can be selected in step 4.

### Switching the display mode of the AV CONTROL CENTER

- 1 Select the "Main Menu" icon in the fixed segment screen by operating the joystick.



- 2 Press the "ENTER" key to enter the selection.



- 3 Select the "Main Menu" icon again.



- 4 Press the "ENTER" key to enter the selection.



- 5 Select the "Display" icon.

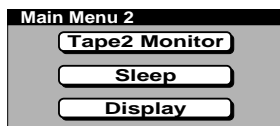

- 6 Press the "ENTER" key to enter the selection.



- 7 Each press of the "ENTER" key switches the display mode.

- It is also possible to select the Tape 2 Monitor or Sleep icon in step 6.

### Selecting the stereo mode

- 1 Select the "Sound" icon in the fixed segment screen by operating the joystick.



- 2 Press the "ENTER" key to enter the selection.



- 3 Select the "STEREO" icon with the joystick.



- 4 Press the "ENTER" key to enter the selection.



- It is also possible to select the Pro Logic, 3 STEREO or Source Direct icon in step 3.



# Controlling the components connected through system control cords

When a CD player, cassette deck and/or LD player are connected with the AV CONTROL CENTER through system control cords, their system control operations are possible from the GRC.

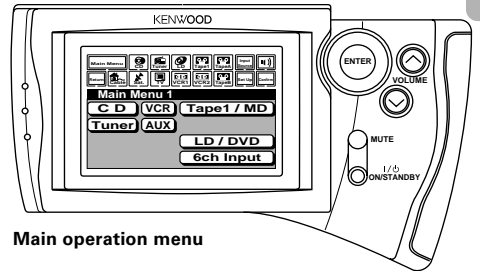

Main operation menu

## Preparations

- System control connection → 7
- Model Type Setup → 12
- Setup of source components → 13

## Operating the tuner

- Select the "Tuner" input.
  - Main Menu
  - ENTER
  - Tuner
  - ENTER
- Display the tuner operation menu.
  - Tuner
  - ENTER
- Select the icon to be operated.
  - Tuner
  - 100.00 P.Call
  - fm MHz 01ch
  - Auto Band Memory / RDS 10key Pad
- Enter the selection (by pressing the "ENTER" key).
  - ENTER

- Any of the keys which can control the tuner can be selected.

## Operating the CD player

- Select the "CD" input.
  - Main Menu
  - ENTER
  - CD
  - ENTER
- Display the CD operation menu.
  - CD
  - ENTER
- Select the icon to be operated.
  - CD
  - Track 01
  - 10key Pad
- Enter the selection (by pressing the "ENTER" key).
  - ENTER

- Any of the CD player operation keys can be selected.
- The menu display shown on the left is an example which appears with a single CD player.

- For the operation of the CD player, also read the instruction manual of the CD player.

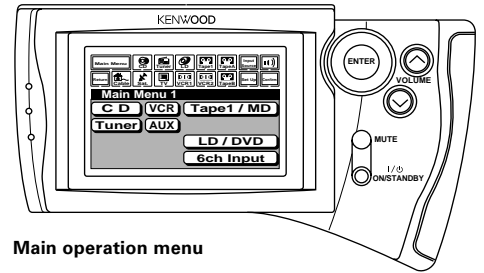

Main operation menu

### Operating the cassette deck

❶ Select the "Tape 1" input.

Main Menu  
ENTER

Tape1 / MD  
ENTER

❷ Display the cassette deck operation menu.

TapeB  
ENTER

❸ Select the icon to be operated.

Tape B

⏪ ⏩ ⏸ ⏹

⏮ ⏭ ⏪ ⏩ ⏸ ⏹

O.T.E. CCRS

❹ Enter the selection (by pressing the "ENTER" key).

ENTER

- The procedure on the left is an example assuming that "Dual" has been selected in the "Setup" operation.
- In case "Single" was selected in the Setup operation, the "Tape 1" icon is displayed.

- Any of the cassette deck operation keys can be selected.

- For the operation of the cassette deck, also read the instruction manual of the cassette deck.

### Operating the LD player

❶ Select the "LD" input.

Main Menu  
ENTER

LD / DVD  
ENTER

❷ Display the LD player operation menu.

LD  
ENTER

❸ Select the icon to be operated.

LD

▶ ⏪ ⏩ ⏸ ⏹ Video CD

Track 01

⏮ ⏭ ⏪ ⏩ ⏸ ⏹ 10key Pad

Mode ⏮ ⏭ ⏪ ⏩ ⏸ ⏹

❹ Enter the selection (by pressing the "ENTER" key).

ENTER

- Any of the LD player operation keys can be selected.
- The procedure on the left is an example assuming that "System Control" has been selected in the "Setup" operation.

- For the operation of the LD player, also read the instruction manual of the LD player.

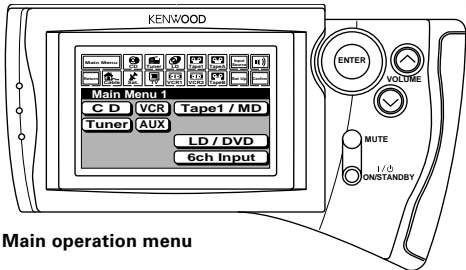

Main operation menu

**Operating the MD recorder**

❶ Select the "MD" input.

Main Menu  
ENTER  
Tape1 / MD  
ENTER

❷ Display the MD operation menu.

MD  
ENTER

❸ Select the icon to be operated.

▶/⏸	◀◀	▶▶	10key
□	●	⏸	PGM
Title Search		Edit	

ENTER

❹ Enter the selection (by pressing the "ENTER" key).

- Any of the keys which can control the MD recorder can be selected.
- For the operation of the MD recorder, also read the instruction manual of the MD recorder.

**Operating the DVD player**

❶ Select the "DVD" input.

Main Menu  
ENTER  
LD / DVD  
ENTER

❷ Display the DVD operation menu.

DVD  
ENTER

❸ Select the icon to be operated.

▶	⏸	◀◀	▶▶	▲	10key
□	◀◀	▶▶	▶▶	▶▶	Mode
Skip	▶▶	⏸	▶▶	▶▶	Ret.
F1	F2	F3	F4		

ENTER

❹ Enter the selection (by pressing the "ENTER" key).

- Any of the DVD player operation keys can be selected.
- For the operation of the DVD player, also read the instruction manual of the DVD player.

# Remote control with the "RC" unit (For C-V301)

C-V351/C-V301 (EN)

## 20 Names and functions of the keys

The "RC" remote control unit provided with the AV CONTROL CENTER can also control KENWOOD cassette decks, CD player and LD player connected to the AV CONTROL CENTER through system control cords. For details of the controllable functions, refer to the instruction manuals of these components.

The RC keys with the same names as the corresponding keys on the main unit have the same function as the main unit keys.

### 1 I/⏻ (POWER) key

Press to switch the AV CONTROL CENTER and the components connected to it through system control cords between ON and STANDBY.

### 2 A ↔ B switch

Some of the RC keys function in two ways. The key functions indicated inside ( ) are usable when this switch is set to B.

Usually set this switch to A. In this manual, the description of a function which requires this switch to be set to B is accompanied with the illustration of .

### 3 Numeric keys

Use these keys as the numeric key of the currently selected input source component.

### 4 TUNER operation keys

- BAND key**  
(RDS DISPLAY key)
- MEMO key**  
(AUTO MEMORY key)
- P.CALL ▾:down key**  
(PTY key)
- P.CALL ▲:up key**  
(TA/NEWS/INFO. key)

### 5 LD player operation key

Read the instruction manual of the LD player.

-  :CX key  
AUTO DIGITAL key

### 6 AV CONTROL CENTER operation keys

- PRO LOGIC key**
- 3 STEREO key**
- DSP key**
- STEREO key**
- SOURCE DIRECT key**
- TEST TONE key**
- MODE key**

Use this key to select the setting modes.

### MULTI CONTROL LEVEL

▲: up key, ▼: down key

Use these keys to adjust the tone or set the surround play.

### TAPE 2 (MONITOR) key

### INPUT key

Use this key as the input selector key.

### MUTE key

Use this key to mute the sound temporarily.

### VOLUME ▲: up key, ▼: down key

Use these keys to adjust the volume.

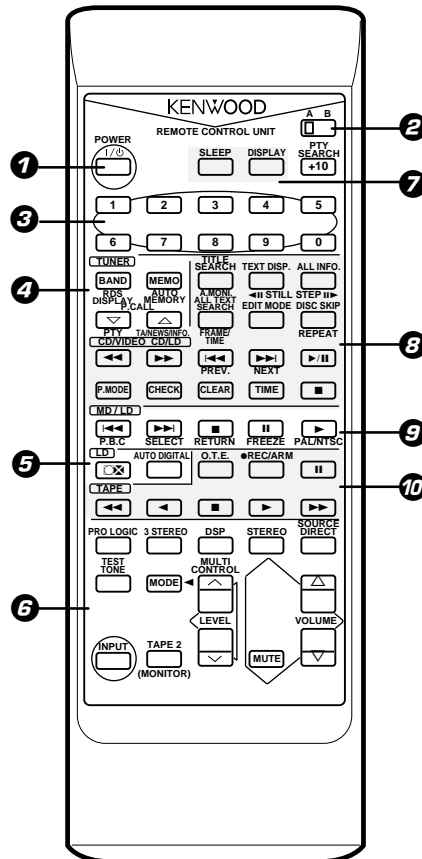

Infrared system  
RC-S0506

### 10 Cassette deck operation keys

Read the instruction manual of the cassette deck.

-  (● REC/ARM key)
- II key**
- ◀◀ key**
- ◀ key**
- key**
- ▶ key**
- ▶▶ key**  
(O.T.E. key)

### 7 Key

#### SLEEP key

Press when setting the sleep timer.

#### DISPLAY key (LD DISPLAY key)

Press to switch the displayed information.

### 8 CD/VIDEO CD/LD player operation keys

Read the instruction manuals of the CD player, VIDEO CD player and/or LD player.

#### TITLE SEARCH key

(A.MONI key)

#### TEXT DISP. key

(STILL STEP ◀◀ key)

#### ALL INFO. key

(STILL STEP ▶▶ key)

#### ALL TEXT SEARCH key

(FRAME/TIME key)

#### EDIT MODE key

#### DISC SKIP key

(REPEAT key)

◀◀ key

▶▶ key

◀◀ key (PREV.)

▶▶ key (NEXT)

▶/II key

P.MODE key

CHECK key

CLEAR key

TIME key

■ key

### 9 MD/LD player-specific operation keys

Read the instruction manual of the MD recorder and LD player.

◀◀ key (P.B.C. key)

▶▶ key (SELECT key)

■ key (RETURN key)

II key (FREEZE key)

▶ key (PAL/NTSC key)

## Loading batteries

1 Slide open the cover.

2 Insert batteries.

3 Close the cover.

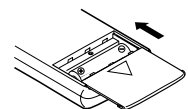
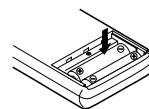
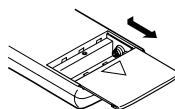

- Insert two AA-size (R6/SUM-3) batteries as indicated by the polarity marking.

## One-touch operation and easy operation features

### (CD player, cassette deck, and DVD player)

When the system is in standby mode, the operations as described below are possible provided that the associated components are connected through system control cords.

#### Preparations

- 1 Ensure that system control cords are connected.
- 2 Set the power switch of the CD player, cassette deck, and DVD player to the ON position.
- 3 Set the power switch of the power amplifier to the ON position.
- 4 Load the source component with the software to be played.
- 5 Press the **I/⏻** key of the AV CONTROL CENTER to put it to standby mode.

- Use the main unit keys for operation.

- The clock information is displayed in standby mode.

#### Function available with the play key operation

- 1 Press the play key.
- 2 The system is switched from standby mode to ON mode.
- 3 The input selector is switched automatically.
- 4 Playback starts.

- CD player, cassette deck, and DVD player

#### Function available with the eject key operation

- 1 Press the eject key.
- 2 The system is switched from standby mode to ON mode.
- 3 The tray panel of the source component opens.

- CD player, cassette deck, and DVD player

- This operation is not available from the eject key of a double cassette deck.

#### Operation available by switching the input selector

- 1 Select the desired input with the input selector.
- 2 The selected source component starts to play.

- Turn on the system before switching the input selector.

- This operation is available when the CD, TAPE 1, MD, LD or DVD input is selected.

# Playing music

The following procedure allows to play a CD, MD, DVD or cassette tape.

## Preparations

- Connect components as described in "System connection". → 5
- Complete "Setup of the Graphical Remote Control (GRC) unit". → 11

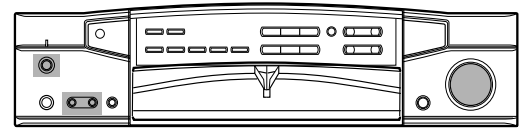

 : Keys or controls to be used in this operation

### 1 Press the ON/STANDBY key to ON.

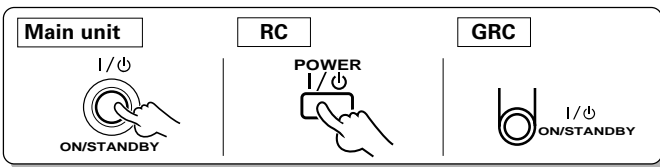

### 2 Select the input source.

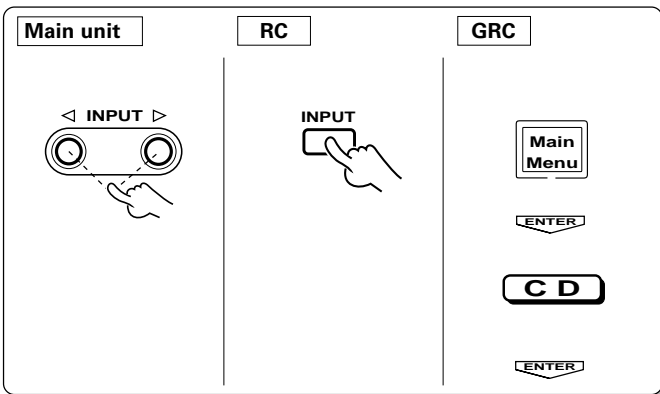

### 3 Play the selected source.

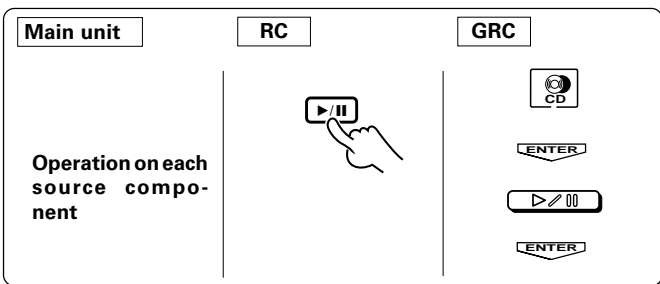

### 4 Adjust the volume.

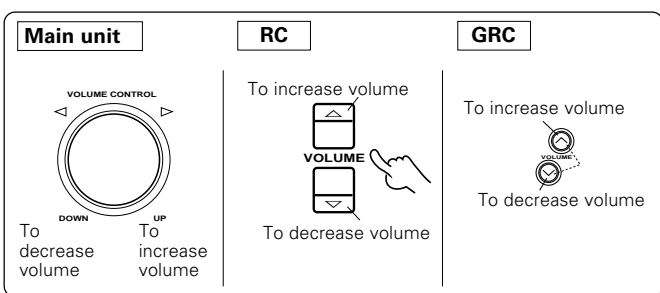

- Load the CD player, MD recorder, DVD player or cassette deck with the software to be played. → Read the instruction manuals of the associated components.

With the main unit operation, the input sources are switched as shown below.

- 1 VCR
- 2 AUX
- 3 TAPE 1 / MD \*1
- 4 TUNER (frequency display)
- 5 CD
- 6 LD / DVD \*2
- 7 6ch INPUT



- \*1: To change the TAPE 1 display to MD display
- \*2: To change the LD display to the DVD display

To enable system-control operation, the displayed information should be set according to the actually connected components. → 10

- Note for using the 6ch INPUT → 25
- Step 3 can be omitted if the easy operation feature is available. → 21



#### One-touch operation

Pressing the play key of the CD player, DVD player or cassette deck starts up the system automatically and starts playback. When this operation is used, steps 1 and 2 can be omitted. → 21

Volume level is displayed.

VOLUME - 50 dB

- The time taken till the volume level is displayed is variable depending on the current operating condition.
- Rotating the **VOLUME CONTROL** at a higher speed increases the amount of volume change (AI VOLUME function).
- The sound of input source cannot be listened to while **TAPE 2 (MONITOR)** is ON.

## Adjusting the tone

**RC**

① Select STEREO.

STEREO

② Select the BASS or TREBLE adjustment.

MODE

③ Adjust the selected item.

To increase

MULTI CONTROL

LEVEL

To decrease

**GRC**

STEREO

ENTER

Set Up

ENTER

Sound

ENTER

Tone/ Balance

ENTER

Bass +8dB

Treble -8dB

ENTER

To decrease

To increase

ENTER

### RC/Main unit

Each press of the **MODE** key switches the adjustment item as shown below.

- ① **BASS** : Tone, Bass
- ② **TREBLE** : Tone, Treble
- ③ **L ----- R** : Balance
- ④ **SW ch** : Subwoofer
- ⑤ **INPUT** : Input level

### GRC

The adjustment menu appears.

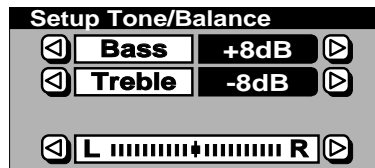

- The display on the GRC disappears if no operation has been performed for about 10 seconds.
- The display on the main unit disappears if no operation has been performed for about 5 seconds.



Display when BASS is selected

The level value changes.

- The level can be adjusted between -8 and +8 in steps of 2.
- The tone cannot be adjusted when the input selector is set to 6ch INPUT.

## Adjusting the left/right sound balance

**RC**

① Select STEREO.

STEREO

② Select the Balance adjustment.

MODE

③ Adjust the selected item.

To decrease left channel level

MULTI CONTROL

LEVEL

To decrease right channel level

**GRC**

STEREO

ENTER

Set Up

ENTER

Sound

ENTER

Tone/ Balance

ENTER

L ----- R

To decrease right channel level

To decrease left channel level

ENTER

### RC/Main unit

Each press of the **MODE** key switches the adjustment item as shown below.

- ① **BASS** : Tone, Bass
- ② **TREBLE** : Tone, Treble
- ③ **L ----- R** : Balance
- ④ **SW ch** : Subwoofer
- ⑤ **INPUT** : Input level

### GRC

- If you proceed to this procedure immediately after that for "Adjusting the tone", you can use the same menu on the GRC.

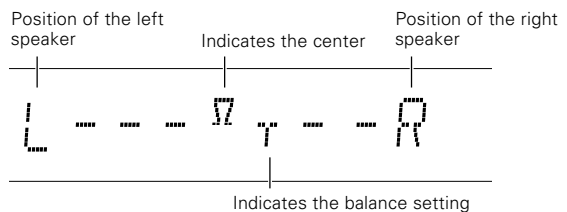

### Source Direct playback

This feature allows you to play the source signal with a high quality by passing it only through the minimum required circuitry.

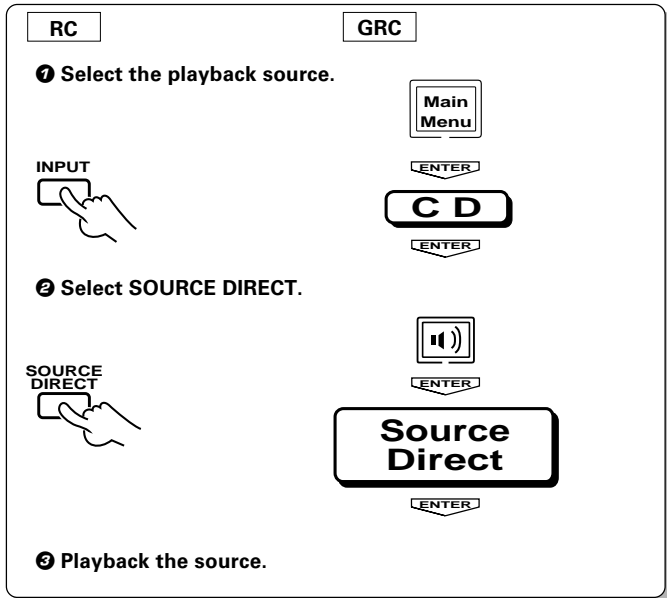

- During Source Direct playback, the tone controls (BASS and TREBLE) and balance control are defeated.
- The Source Direct playback is canceled when any key associated with the surround play is pressed.
- The Source Direct playback is not possible when the 6ch INPUT is selected.

#### To cancel

Select the Source Direct (S.DIRECT) again.

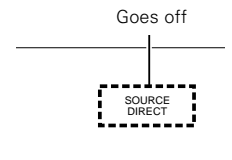

### To listen through headphones

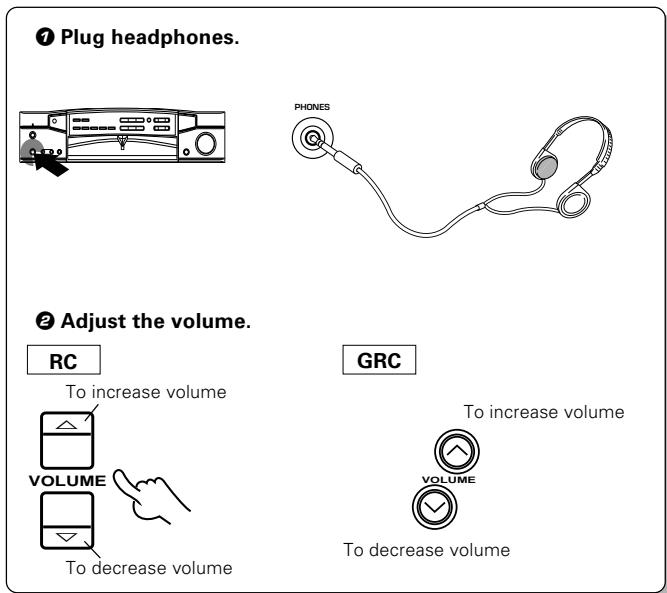

- The speaker sound is defeated at the moment headphones are inserted into the **PHONES** jack.
- If headphones are plugged in during surround play, its mode is automatically switched to the STEREO mode. If they are plugged in during 6ch INPUT play, only the front L ch and R ch will be played. The previous status resumes at the moment headphones are unplugged.
- If headphones are plugged in during test tone output, the test tone output stops.

### To mute sound temporarily

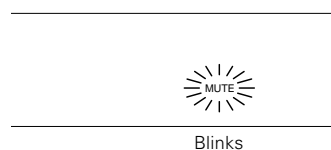
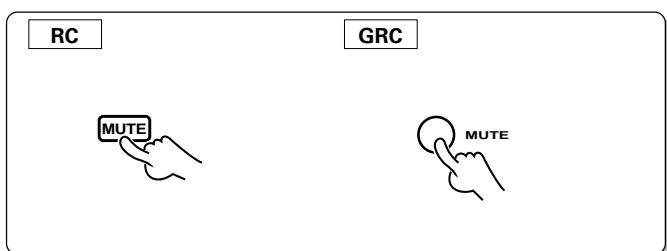

#### To cancel

Press the MUTE key again.



When recording sound with a recorder component of KENWOOD, synchro recording is possible by setting the INPUT SELECTOR to select TAPE1 or MD according to the connected component.

## To record a music source

RC
GRC

**1 Select the source to be recorded.**



ENTER

When recording on TAPE, for source, select anything except TAPE1.  
When recording on MD, for source, select anything except MD.

INPUT



**Main Menu 1**

C D	VCR	Tape1 / MD
Tuner	AUX	LD / DVD
6ch Input		

ENTER

**2 Set the recording unit (cassette deck or MD recorder) to recording mode.**

**3 Play the source and start recording.**

### RC/Main unit

Each press switches the indication.

- ① VCR
- ② AUX
- ③ TAPE 1 / MD \*1
- ④ TUNER (frequency display)
- ⑤ CD
- ⑥ LD / DVD \*2
- ⑦ 6ch INPUT

### GRC

Select the icon of the source to be played.

- \*1\*2 The TAPE 1 display can be changed to the MD display and the LD display can be changed to the DVD display. → 10
- For the recording using a cassette deck or MD recorder, read the instruction manual of the cassette deck or MD recorder.
- Recording sound from a MD recorder onto TAPE 1 is not possible because the input selection is overlapped.
- Remember that varying the input level during recording causes the recording level to be varied.
- The EON overriding does not occur during recording.

## Notes for using the 6ch INPUT source

When 6ch INPUT is selected as the input source, the operation is subjected to the following restrictions.

1. Neither the video or audio can be recorded.
2. The monitor function cannot be activated by pressing the **TAPE 2 (MONITOR)** key.
3. Surround play, its adjustment, STEREO mode play, tone adjustment and Source Direct play are not available.

## Regarding TAPE 2 (MONITOR)

A cassette deck or graphic equalizer can be connected to this unit's **TAPE 2 (MONITOR)** terminals. If you connect a graphic equalizer, turn the **TAPE 2 (MONITOR)** key ON. If you connect a 3-head cassette deck, you can monitor the source sound, or the sound being recorded, while recording. Pressing the **TAPE 2 (MONITOR)** key lets you compare the recorded sound and the source sound. Refer to the operating manual for the component you connected for further details.

# Broadcast reception

Radio stations can be classified into RDS (Radio Data System) stations and other stations. For listening to RDS stations or storing RDS stations in preset memory, see section entitled "Functions of RDS". - 27

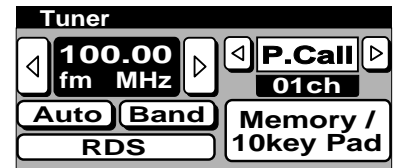

Main operation menu

## Receiving broadcast station

### 1 Select the TUNER input.

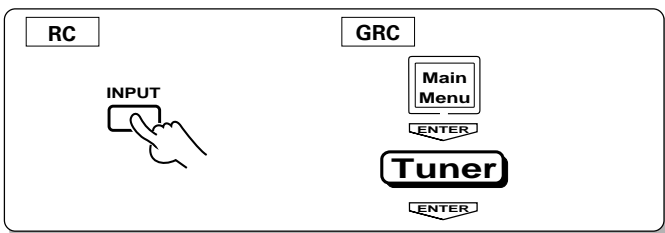

#### RC/Main unit

Each press switches the indication.

- ① VCR
- ② AUX
- ③ TAPE 1 / MD
- ④ TUNER (frequency display)
- ⑤ CD
- ⑥ LD / DVD
- ⑦ 6ch INPUT

### 2 Select the broadcast band.

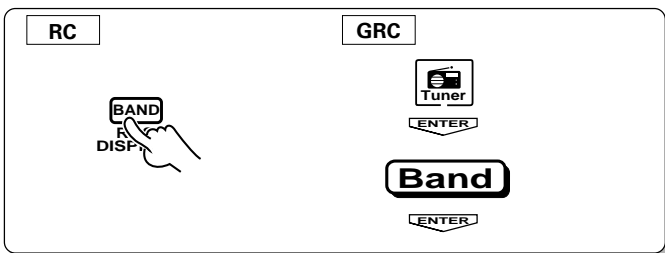

Each press switches the indication.

- ① FM
- ② MW (AM)
- ③ LW (U.K. only)



"FM", "MW(AM)" or "LW" indicator

- You can also start the procedure from step 2 by omitting step 1.

### 3 Select the tuning method.

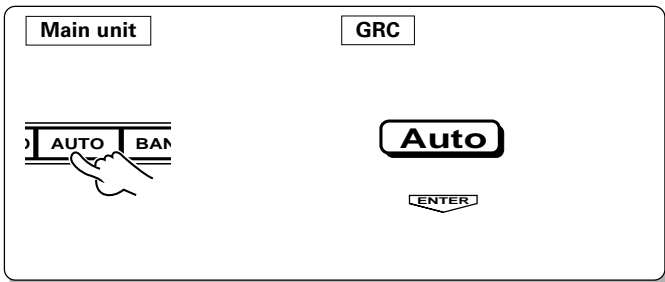

Each press switches the indication.

- ① AUTO lit (auto tuning)
- ② AUTO not lit (manual tuning)

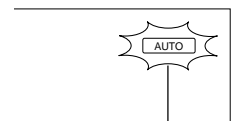

Lights up

- Usually, set the switch to **AUTO** (auto tuning).

Select manual tuning when noise interferes due to weak radio wave. (The stereo broadcasting is received in monaural during manual tuning.)

### 4 Select a station.

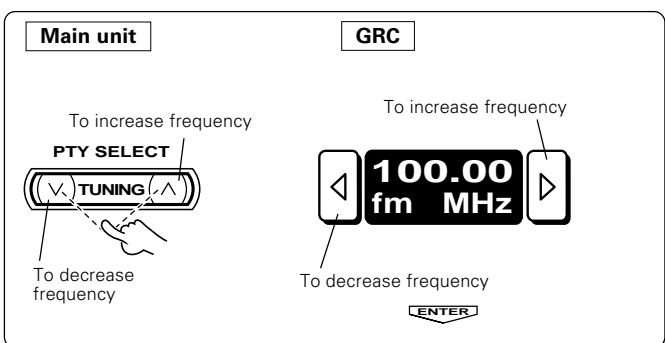

Frequency display

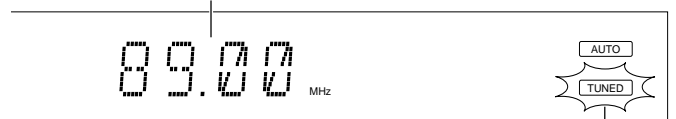

"TUNED" lights up when a station is tuned.

- Auto tuning : The next station found is tuned automatically.
- Manual tuning : Press repeatedly or hold until a station is tuned.

## Functions of RDS

RDS is a system which transmits useful information (digital data) for FM broadcasts together with the broadcast signal. Tuners and receivers designed for RDS reception can extract the information from the broadcast signal for use with various functions such as automatic display of the station name.

### Functions made possible with RDS

#### PTY (Program Type Identification) Search :

The tuner automatically searches for a station which is currently broadcasting a specified program type (genre).

#### EON (Enhanced Other Network) reservation

By selecting one of the three kinds of programme previously, the tuner switches automatically to a station broadcasting that kind of program whenever it starts broadcasting. When the broadcasting completes, the tuner returns automatically to the originally-received station.

#### PS (Program Service Name) Display : See figure ① below.

When an RDS broadcast is received, the station name is automatically displayed.

#### AUTO MEMORY

This function automatically selects the stations providing RDS and FM broadcasting and stores them in the preset memory (up to 40 stations can be preset).

The RDS indicator lights up when an RDS broadcast (signal) is received.

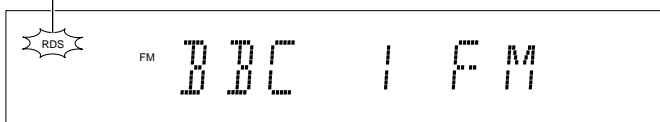

\* Some functions may not be provided or be given different names depending on countries or areas.



Before using a function utilizing the RDS, be sure to perform the AUTO MEMORY operation by referring to the description in "Storing RDS stations automatically in the preset memory".

## DISPLAY key

RC

GRC

Pressing the RDS DISPLAY key changes the display contents.

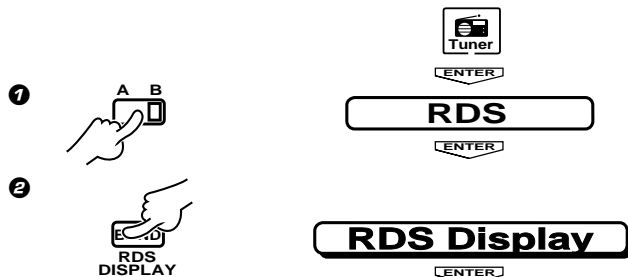

### Display mode priority ranking

When an FM broadcast is received :

- ① PS (Program Service Name) Display
- ② Frequency Display

- ① PS (Program Service Name) Display :  
When an RDS broadcast is received, the station name is automatically displayed.  
If no PS data was sent, "NO PS" is displayed.
- ② Frequency Display :  
The frequency of the current station is displayed.

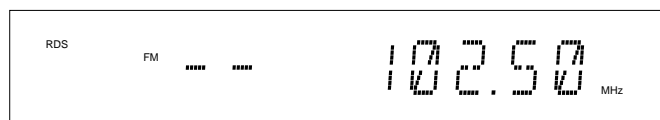
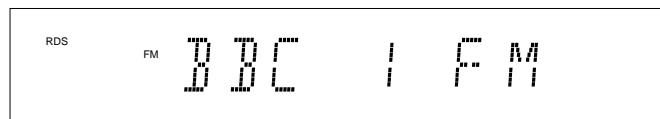

Use the operating procedure on this page to store RDS stations automatically in preset memory. Up to 40 RDS stations can be preset and received with a simple key operation.

This unit is compatible with the RDS so it can use convenient RDS functions including automatic tuning and EON reservation.

RDS stations should be stored in the preset memory following the procedure in "Storing RDS stations automatically in preset memory" before listening to RDS stations.

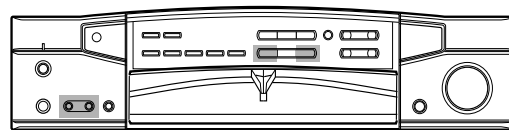

 : Keys or controls to be used in this operation

## Storing RDS stations automatically in preset memory (AUTO MEMORY)

The following procedure allows to select stations broadcasting RDS broadcast and store them in the preset memory (up to 40 stations can be preset).

### 1 Set the INPUT SELECTOR to "TUNER".

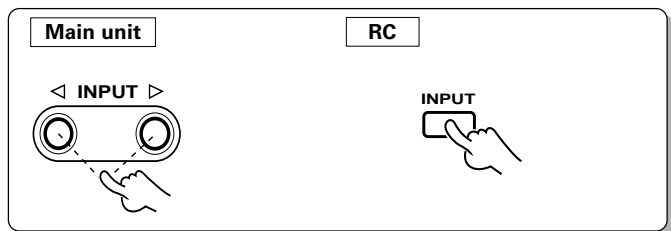

#### RC/Main unit

Each press switches the indication.

- ① VCR
- ② AUX
- ③ TAPE 1 / MD
- ④ TUNER (frequency display)
- ⑤ CD
- ⑥ LD / DVD
- ⑦ 6ch INPUT

- The previously tuned frequency is displayed.

### 2 Set the receiving band to "FM".

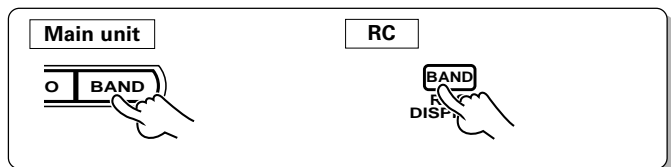

Each press switches the indication.

- ① FM
- ② MW (AM)
- ③ LW (U.K. only)

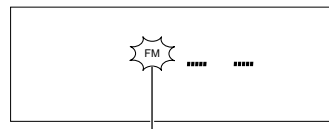

The "FM" indicator should light.

### 3 Preset radio stations by AUTO MEMORY.

**Main unit**

Press the A.MEMO key.

**RC**

In a few minutes, the stations with which RDS broadcast is received are stored in order beginning from preset channels "01" (up to 40 stations can be preset).  
When the number of stations providing RDS broadcasting is less than 40, some of other FM stations will be preset in the vacant channels.

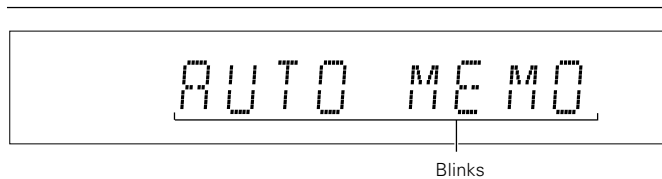

- If stations have already been stored in preset channels, the same number of these preset channels as the number of stations are cleared and replaced with the data of the newly preset stations.

## Receiving a preset RDS station

**RC**

PTY SEARCH  
+10

**GRC**

Enter the preset number (max. 40) of the desired RDS station.

Press numeric keys in the order as described below:... (RC)

To enter "15" ..... **+10**, **5**

To enter "20" ..... **+10**, **+10**, **0**

Press numeric keys in the order as described below:... (GRC)



To enter "15" ..... **+10** **CENTER** **5** **CENTER**

To enter "20" ..... **+10** **CENTER** **+10** **CENTER** **0** **CENTER**

- If you commit a mistake in entering the digit of 10, press the **+10** key several times to return to the original display and re-enter the preset number from the beginning.
- Press the **RDS DISPLAY** key to change the displayed information.

The AUTO MEMORY function gives precedence to RDS stations and assigns them from preset number 1. Therefore, when it is required to preset RDS stations as well as non-RDS stations, execute the AUTO MEMORY operation first then proceed to the manual memory operation of non-RDS stations.

### Preparation

- Select the **TUNER** input. 
- Display the Tuner operation menu. 

### Order of radio station presetting



Other stations than the RDS stations can be stored in the preset memory by presetting them after the RDS stations preset by AUTO MEMORY as shown below or overwriting the RDS stations preset in some preset numbers.



Preset number		
1 2	.....	39 40
① AUTO MEMORY RDS stations (~ FM stations)	~	② Manual memory FM stations or LW or MW stations

## Storing radio stations manually in preset memory

RC

GRC

- Select the receiving band.
- Select a station or frequency.
- Press the Memory key during receiving a station.

Proceed to step ④ within 10 sec. (If more than 10 sec. have elapsed, press the **Memory** key again.)

**Memory / 10key Pad**  
  

**Memory**

  

- Select one of the preset numbers from 1 to 40.

PTY SEARCH  
+10

1	2	3	4	5
6	7	8	9	0

1	2	3
4	5	6
7	8	9
0	+10	



- Apart from the auto memory function, RDS stations can also be stored manually in the preset memory.
- In the manual memory storage operation of radio stations, it may take a few minutes after the **Memory** key is pressed till the memory display starts to blink depending on the receiving condition.

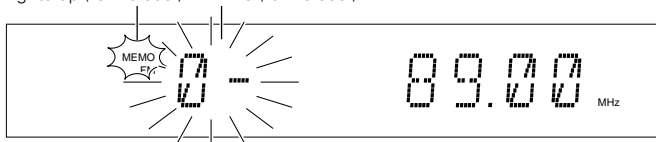

Lights up (for 10 sec.)    Blinks (for 10 sec.)



Press the numeric keys in the following order... (RC)

To store in "15" ..... **+10**, **5**

Press the numeric keys in the following order... (GRC)

To store in "15" ..... **+10**  **5** 

- Repeat steps ①, ②, ③, ④ for each of the stations to be stored in memory.
- If a station is stored in a preset number which has already stored a station memory under it, the previous memory is replaced by the new memory content.
- If RDS stations are stored manually in the preset memory, the PS may not be included in the memory depending on receiving conditions.

## Receiving a preset station

RC

GRC

Enter the preset number (max. 40) of the desired station.

PTY SEARCH  
+10

1	2	3	4	5
6	7	8	9	0



1	2	3
4	5	6
7	8	9
0	+10	



Press the numeric keys in the following order... (RC)

To recall "15" ..... **+10**, **5**

Press the numeric keys in the following order... (GRC)

To recall "15" ..... **+10**  **5** 

- If you make a mistake in entering the figure of 10, press the **+10** key repeatedly until the original display is shown, then enter the correct number.

Preset number stored in memory

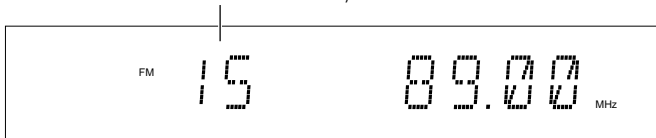

## Receiving all preset stations in order (P. CALL)

RC

GRC

The preset number decreases.



PTY TA/NEWS/INFO.

The preset number increases.



The preset number decreases.



The preset number increases.



**P.Call**

**01ch**



- Every time the key is pressed, the next station in the order of the preset number is received.

When you press **P.Call**  key, .....

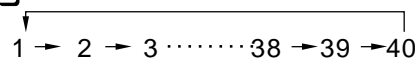

When you press  **P.Call** key, .....

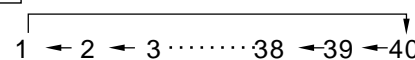

If the key is held pressed ..... Preset stations will be received successively for about half a second each.

By specifying the type of program (genre) you want to listen to, the tuner automatically searches for a station which is currently broadcasting a program of the specified type.

With certain receiving conditions, it may take more than 1 minute until the search completes.

**Preparation**

- Preset RDS stations with the **AUTO MEMORY** function.
- Select the **TUNER** input.
- Set the receiving band to **FM**.



Main operation menu

## Searching for a desired program type (PTY search)

### 1 Select the PTY search mode.

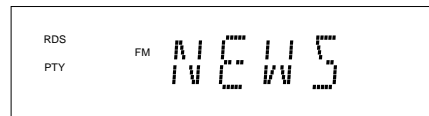
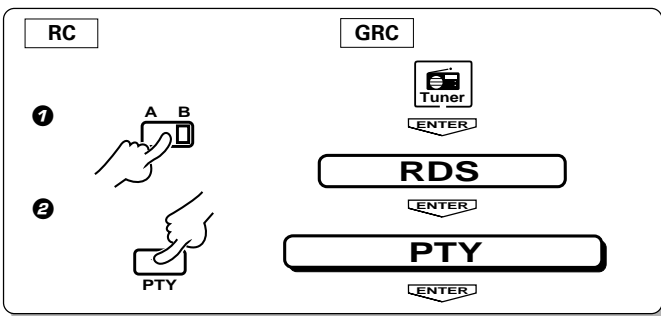

When an RDS broadcast is received, the program type is shown on the display. If no PTY data is available, or if the station is not an RDS station, "NONE" is displayed.

### 2 Select the desired program type.

Use program type table on the right for your convenience.

**Main unit**      **GRC**

**(A) When selecting with the up or down keys**

**PTY SELECT**

Previous programme type      Next programme type

Previous programme type      Next programme type

Select while "PTY" is lit.

The **up** or **down** key allows to select desired programme types from the 29 types. Press and hold the key and release it when the desired type is displayed.

---

**RC**      **GRC**

**(B) When selecting with the numeric keys**

The **numeric** keys allow to select the desired one of programme types 1 to 0 directly. If you want to select other programme type than them, use the **TUNING** key.

### Program type table

(A)	(B)	Program Type Name	Display
(V) DOWN  UP (^)	1	Pop Music	POP M
	2	Rock Music	ROCK M
	3	*M.O.R. Music	M.O.R. M
	4	Light Classic Music	LIGHT M
	5	Serious Classic Music	CLASSICS
	6	Other Music	OTHER M
		Weather	WEATHER
		Finance	FINANCE
		Children's programmes	CHILDREN
		Social affairs	SOCIAL A
		Religion	RELIGION
		Phone in	PHONE IN
		Travel	TRAVEL
		Leisure	LEISURE
		Jazz Music	JAZZ
		Country Music	COUNTRY
		National Music	NATION M
		Oldies Music	OLDIES
		Folk Music	FOLK M
		Documentary	DOCUMENT
	7	News	NEWS
	8	Current Affairs	AFFAIRS
	9	Information	INFO
	0	Sport	SPORT
		Education	EDUCATE
		Drama	DRAMA
		Cultures	CULTURE
		Science	SCIENCE
		Varied Speech	VARIED

\*M.O.R. Music (Middle of the Road Music)

"NO DATA" is displayed if this operation is attempted before performing the **AUTO MEMORY** operation.

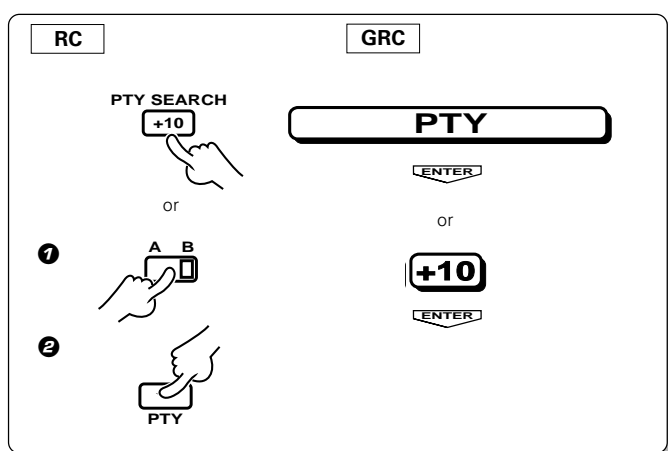
**3** Start the search.**To change to a different program type:**

Repeat steps 2, 3.

**When searching for a Rock Music broadcast.**

Display while the tuner is searching.

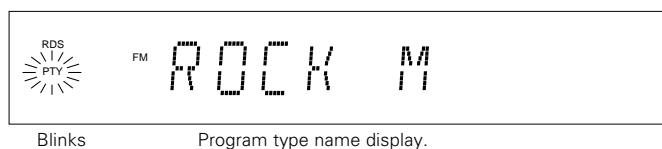

Blinks Program type name display.

When a station is received.

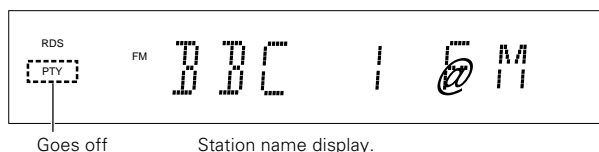

Goes off Station name display.

- No sound is heard while "PTY" is blinking.
- If a program of the desired type cannot be found, "NO PROG" is displayed, then after several seconds the display returns to the original display.
- When a station with the selected programme type is searched, its reception starts and the type name display changes to the station name display.

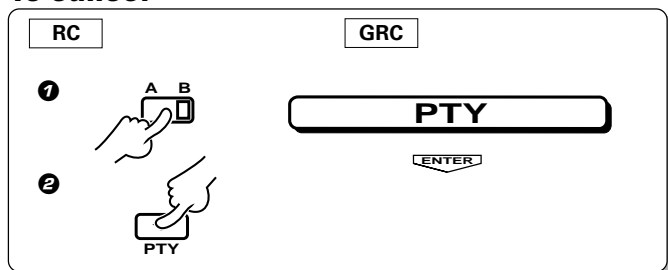
**To cancel**

The EON function manages the kinds of information broadcast by other stations than the currently received stations, so that you can make reservation of the desired kind of programme, such as traffic announcement and news, even when there is no station broadcasting it at the present. When a station starts broadcasting a programme of the reserved kind while you are listening to a station with which the EON indicator lights up, the tuner tunes the station automatically. When the station completes the programmed of the reserved kind, the tuner automatically returns to the originally-received station.

**Preparation**

Perform steps 1 to 2 of "Storing RDS stations automatically in preset memory (AUTO MEMORY)". → 28



This step can be omitted if you have already executed the AUTO MEMORY procedure.

- The EON function cannot be used if all of the 40 preset stations have been stored using the procedure in "Storing radio stations manually in preset memory". Be sure to use the AUTO MEMORY function.

**Reserving reception of desired kind of programme in advance (EON reservation)**

**1 Set the receiving band to FM.**

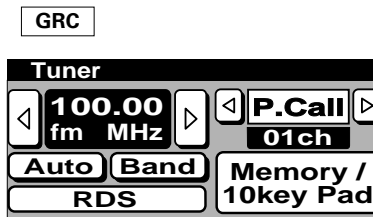
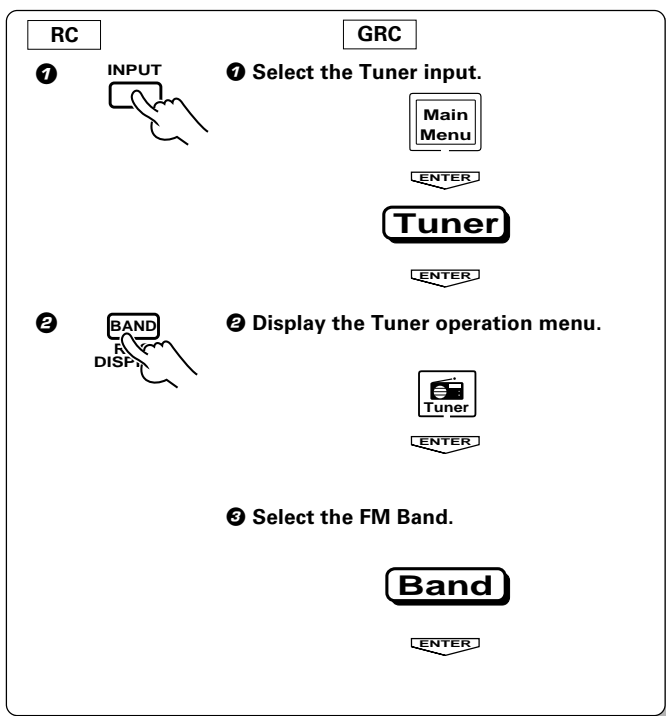

**2 Select the desired kind of programme.**

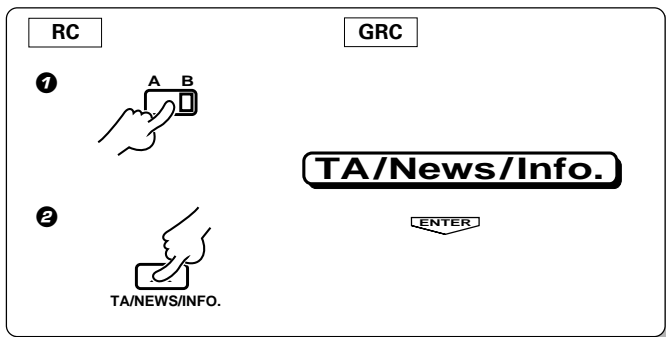

Display when "TA" is selected "TP" lights for stations where TP (Traffic Program) can be received.

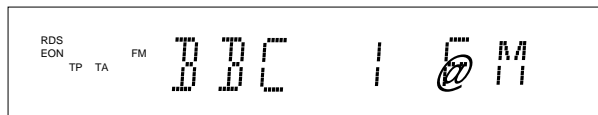

Each press switches the indication.

- ① TA (Traffic Announcement)
- ② NEWS (News :Programme type)
- ③ INFO. (Information :Programme type)
- ④ Goes off (EON cancelled)

- If none of TA, NEWS and INFO. can be selected, execute the AUTO MEMORY procedure again. → 28



### TP (Traffic Programme) indication

When the "TP" indicator is lit, this means that the presently-received station or a station in the same network is transmitting traffic information. When "TP" is displayed for the station being received, the traffic information of this station can be received without EON reservation.



Main operation menu

### 3 Receive one of RDS stations.

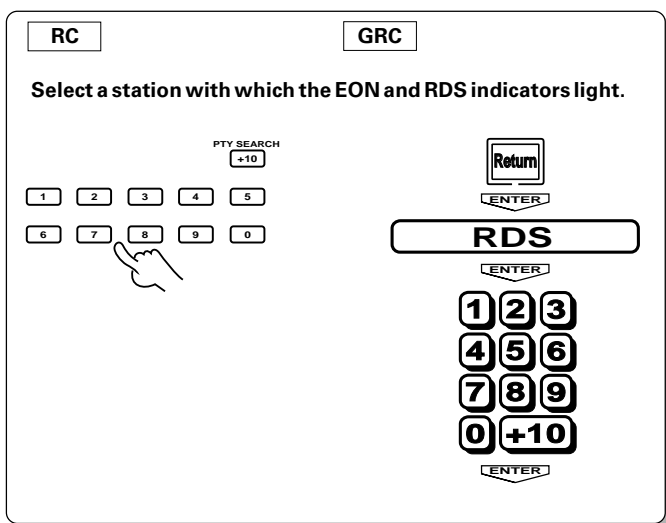

Press numeric keys in the order as described below:... (RC)

To enter "15" ..... [+10], [5]

Press numeric keys in the order as described below:... (GRC)

To enter "15" ..... [+10] [ENTER] [5] [ENTER]

- If you commit a mistake in entering the digit of 10, press the [+10] key several times to correct.
- Radio stations can also be selected by pressing the P.CALL Up or Down key.

Display when "TA" is selected

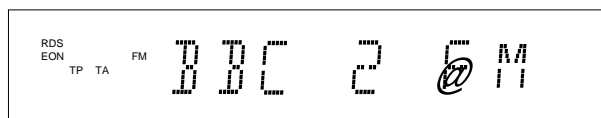

- If you want to reserve TA, receive a station with which the TP indicator lights.
- When "EON" does not light although an RDS station is received, that station is not transmitting EON data. Please select a different station.

### 4 Wait for a reserved reception to start.

Leave the station with which the EON and RDS indicators light tuned in. The tuner stands by for the reception provided that the power is left ON.

#### To keep listening to a tuner station:

Receive a station with which the "EON" and "RDS" indicators light.

#### To listen to other source than tuner:

- ① While keeping the tuner tuned into a station with which the "EON" and "RDS" indicators light, select the desired source with the INPUT SELECTOR.
- ② Even when the INPUT SELECTOR is set to other source than TUNER, it is switched automatically to TUNER when EON-reserved broadcast starts.  
If the source selected in ① is LD, it continues to be played in this period but the sound is not heard.
- ③ When the EON-reserved reception completes, the INPUT SELECTOR returns to the previous input source.

- When the unit is in STANDBY mode, the EON function does not operate.
- When the transmission of the selected program contents ends in case of automatic reception with the EON function, return will be made to the status directly before operation of the EON function.

### When waiting for information while listening to an RDS station without the EON function

If the "EON" indicator does not light in steps 3 and 4 and the desired kind of information has already been selected, the information from only the station being received will be waited for.

### To cancel EON reservation

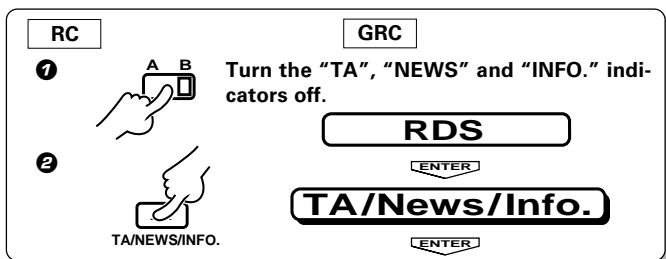

Each press switches the indication.

- ① TA
- ② NEWS
- ③ INFO.
- ④ Goes off

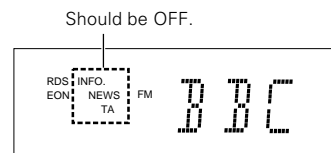

This AV CONTROL CENTER incorporates 3 different sound modes to let you enjoy surround sound with a wide variety of program sources. The Dolby Pro Logic surround sound let you enjoy theater-like surround effects when you play Dolby Pro Logic program sources (like Laserdiscs and DVDs). Dolby 3 Stereo creates a panoramic frontal sound field. The Digital Signal Processing (DSP) modes let you create a variety of different sonic environments from almost any type of program source. To obtain the best possible surround sound, be sure to complete "Setup for surround play" before using the surround modes.

## Sound modes

### Dolby Pro Logic

Dolby Pro Logic is a specially encoded 2 channel surround format designed to provide theater-like surround sound from Dolby Surround encoded sources (such as video and Laserdisc software marked ). This AV CONTROL CENTER is equipped with a Dolby Pro Logic surround decoder to let you enjoy the wide variety of currently available Dolby Surround home video software.

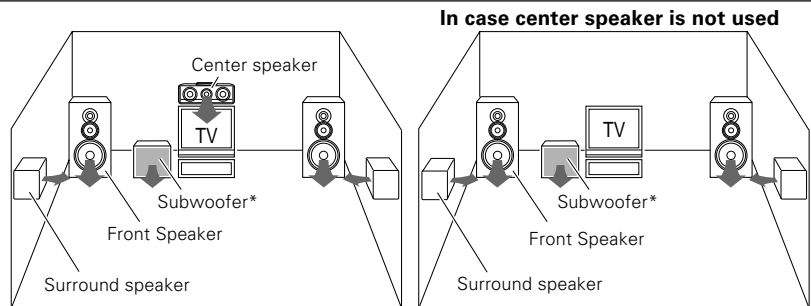

\* Optional in this mode.

### Dolby 3 Stereo

Dolby 3 Stereo is available for systems that do not have surround speakers. When in the Dolby 3 Stereo mode the surround information is redirected to the front left and right speakers. This mode is designed for use with Dolby Surround program sources, but can also improve sound field unity for programs that are not Dolby Surround encoded. Dialog positioning and sound image definition, however, may not be as accurate when used with programs that are not Dolby Surround encoded.

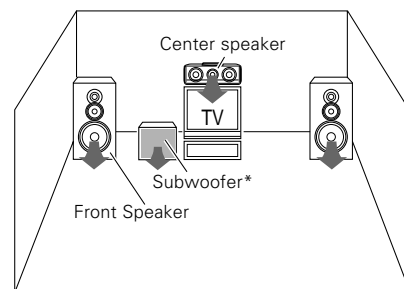

\* Optional in this mode.

### **DSP mode**

The DSP mode lets you add the atmosphere of an arena, jazz club, or stadium to almost any type of program source.\* These modes are particularly effective when used with stereo program sources, like CD, television, and FM radio. You might enjoy trying the STADIUM or ARENA mode the next time you watch a concert or sporting event! The EFFECT level lets you adjust the "presence" of the sonic environment according to your preference.

\* The DSP mode will produce a stereo-like surround effect from monaural sources, but there will be some reduction in the presence of the arena, jazz club, or stadium (etc.).

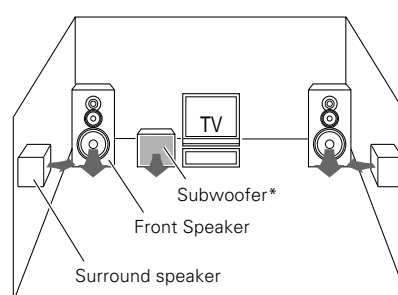

\* Optional in this mode.

### **Recommended speaker installation**



It is recommended that the surround speakers are installed straight to the left and right of the listening position or slightly behind, at a height of about 1 meter higher than the listener's ears.

### **What is DSP?**



The DSP stands for Digital Signal Processor. In the DSP presence mode, the reverberation components (elements of sound echoed in various spaces) which determine the feeling of presence are created by digital processing by the DSP without spoiling the sound quality of the original music source.

The feeling of presence in the surround effects can be improved by performing the following adjustment procedure according to the speaker system and listening room environment in use. Once they are adjusted, re-adjustment is not necessary even after the surround mode is switched to other modes.

Adjustment sequence

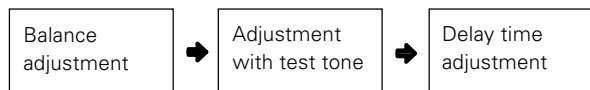

Setup Sound	
Test Tone	DSP
Delay Time	Tone/Balance
Speaker Level	-6dB
Input Level	

Main operation menu

# Setup for surround play

## 1 Select the Dolby Pro Logic surround mode.

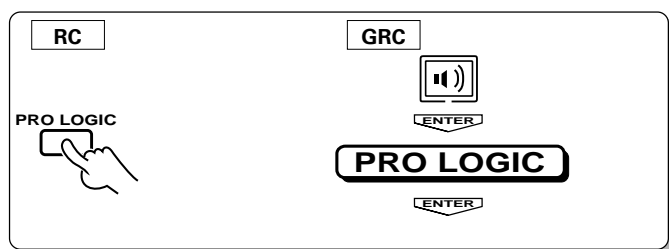

- Select the surround mode according to the played source and component in use.
- Switching is not possible when the 6ch INPUT is used.

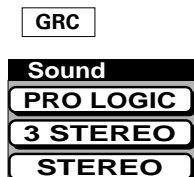

Select an icon.

## 2 Adjust the balance. "L- - - - -R"

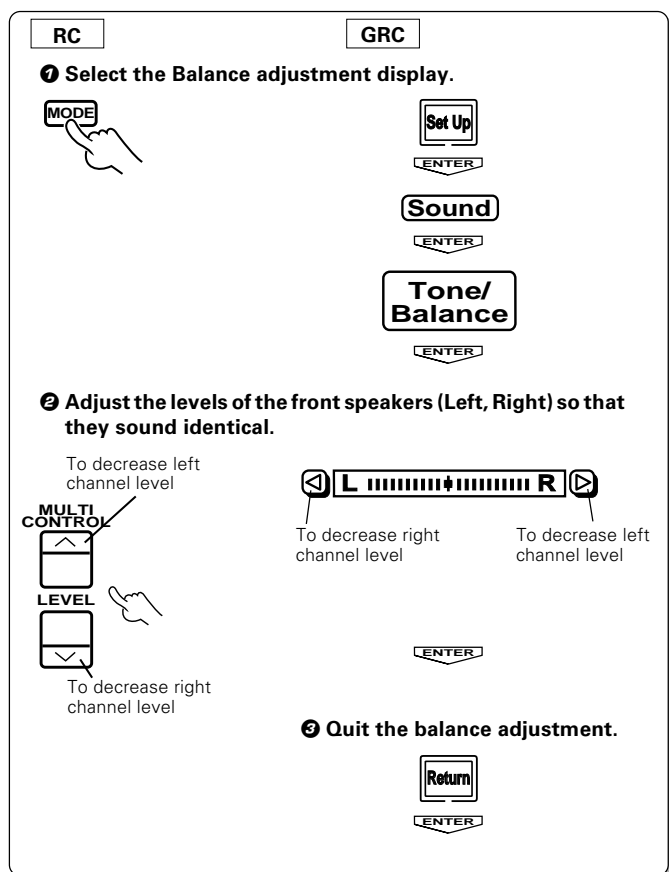

### RC/Main unit

Each press switches the adjusted items as shown below.

- ① **BASS** :Tone, Bass
- ② **TREBLE** :Tone, Treble
- ③ **L- - - - -R** :Balance
- ④ **C ch** :Center speaker
- ⑤ **SR ch** :Surround speaker, Right
- ⑥ **SL ch** :Surround speaker, Left
- ⑦ **SW ch** :Subwoofer
- ⑧ **DELAY** :Delay time
- ⑨ **INPUT** :Input level

- Adjustment items ⑤, ⑥ and ⑧ are not required in the 3 STEREO mode.
- The adjusted items which can be selected with 6ch INPUT are ③, ④, ⑤, ⑥ and ⑦, in this sequence.
- Those which can be selected when SOURCE DIRECT is ON are ⑦ and ⑨.

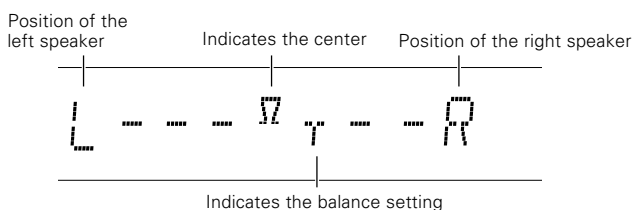

If no key on the main unit has been pressed for about 5 seconds, the display on the main unit disappears and it returns to the status before the setup mode was entered. The display on the GRC disappears if no key on the GRC has been pressed for about 10 seconds.

### How to calculate the proper delay time

Assuming that the distance from the front speakers is A meters and that from the surround speakers is B meters:

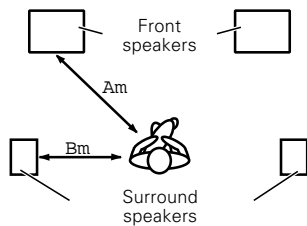

### What is delay time?



The sound entering the ears include the direct sound coming from the sound source and the indirect sounds reflected from the walls, floor, ceiling, etc. The indirect sounds are delayed because they travel longer distance required for reflection before they reach the ears. The delay time is the difference in time between the direct sound and indirect sounds.

#### ① Use the delay time calculation chart on the right.

Example:  
When A = 3 m, B = 3 m,  
the delay time is 20 ms.

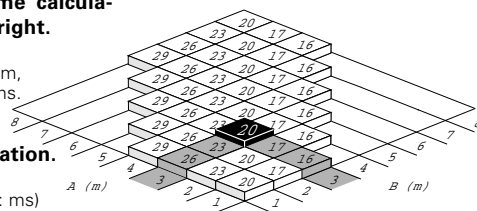

#### ② Use the following formula for calculation.

$$\text{Delay time} = 20 + 3 \times (A - B) \text{ (Unit: ms)}$$

### 3 Adjust the level from each speaker. "Test Tone"

RC
GRC

**① Output the "Test Tone".**

**② Adjust the levels of the other speakers than the front speakers (left, right).**

(1) While test tone is output from a speaker,  
(2) Adjust the volume level of the speaker.

To increase level

↑

LEVEL

↓

To decrease level

Channel Level

SL+10dB

To decrease level

←

To increase level

→

**③ Quit the speaker level adjustment.**

- The test tone which sounds like noise move across speakers in the following sequence every 1.5 second.

(In Pro Logic mode)

- ▶ **TEST Lch** (Front speaker, Left)
- ▶ **TEST Cch** (Center speaker)
- ▶ **TEST Rch** (Front speaker, Right)
- ▶ **TEST SRch** (Surround speaker, Right)
- ▶ **TEST SLch** (Surround speaker, Left)

(In 3 STEREO mode)

- ▶ **TEST Lch** (Front speaker, Left)
- ▶ **TEST Cch** (Center speaker)
- ▶ **TEST Rch** (Front speaker, Right)

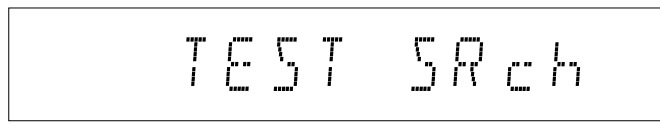

Display when test tone is output from a surround speaker

- Be sure to adjust from the listening position.
- Each press of the key increases or decrease the level by 1 dB.
- The levels of the front speaker (Left, Right) cannot be varied in step 2.

### 4 Adjust the delay time. "DELAY"

RC
GRC

**① Select the Delay Time adjustment display.**

**② Adjust the Delay Time.**

To increase

↑

LEVEL

↓

To decrease

Delay Time

20msec

To decrease

←

To increase

→

**③ Quit the delay time adjustment.**

#### RC/Main unit

Each press switches the adjustment items as shown below.

- ① **BASS** :Tone, Bass
- ② **TREBLE** :Tone, Treble
- ③ **L- - - - -R** :Balance
- ④ **C ch** :Center speaker
- ⑤ **SR ch** :Surround speaker, Right
- ⑥ **SL ch** :Surround speaker, Left
- ⑦ **SW ch** :Subwoofer
- ⑧ **DELAY** :Delay time
- ⑨ **INPUT** :Input level

- Adjustment items ⑤, ⑥ and ⑧ are not required in the 3 STEREO mode.
- Find the optimum delay time for the listening room by referring to "How to calculate the delay time".
- The delay time in the PRO LOGIC mode can be adjusted between 15 and 30 ms.
- Select the closest value to the value obtained by "How to calculate the delay time".

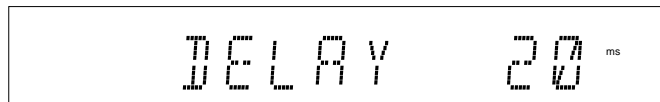

Delay time

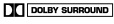
Dolby Pro Logic and Dolby 3 Stereo can be used when playing video, DVD, or LD software bearing the  mark. DSP modes can be used with any source. Be sure to complete "Set up for surround play" before using any of these surround modes. - 36

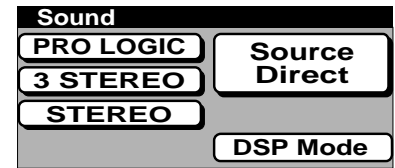

Main operation menu

## Surround play

### 1 Select the desired mode.

RC
GRC

To select the PRO LOGIC mode:

  
ENTER  

PRO LOGIC

  
ENTER

---

To select the DSP mode:



  
ENTER  

DSP Mode

  
ENTER

Selection cursor

Sound DSP Mode





Arena

ENTER

- Switching is not possible when the 6ch INPUT is used.

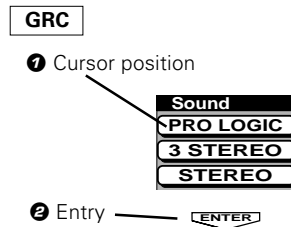
When the Dolby surround mode is selected:



When the DSP mode is selected:

RC/Main unit

Each press of the **DSP** key switches the sound fields as shown below.

- ① **ARENA** :A lively feeling as felt in the frontmost seat in a concert arena.
- ② **JAZZ CLUB** :Sound field of a jazz live house where cymbals sound sharply.
- ③ **STADIUM** :A free feeling with little reverberation reflected from the ceiling.

- When the DSP mode is selected, the center speaker does not output sound.
- Sound parameter adjustments in DSP mode - 43

### 2 Play video software.

### 3 Adjust the sound level.

### To end surround play

RC
GRC

  
ENTER  

STEREO

  
ENTER

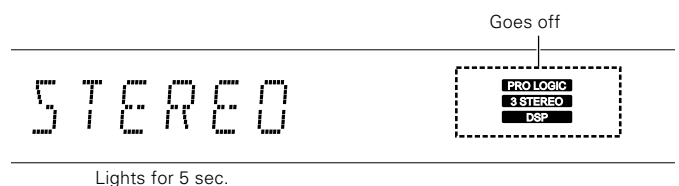

Manufactured under license from Dolby Laboratories.  
 "DOLBY", the double-D symbol and "PRO LOGIC" are trademarks of Dolby Laboratories.

The setup for surround play can also be performed by listening to actual music instead of the test tone. Use the following procedure to adjust surround play while listening to music.

### Preparations

- Play video software marked **DOLBY SURROUND**.



Main operation menu

## Setup for surround play (while listening to music)

### 1 Select the Dolby Pro Logic surround mode.

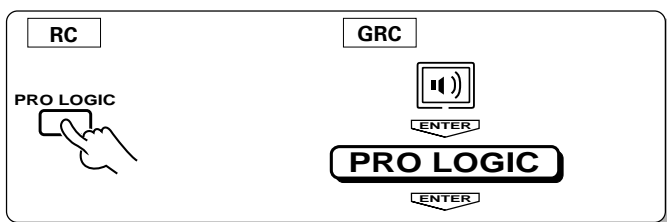

- Select the surround mode according to the played source and component in use.
- Switching is not possible when the 6ch INPUT is used.

### 2 Adjust the adjustment item (example).

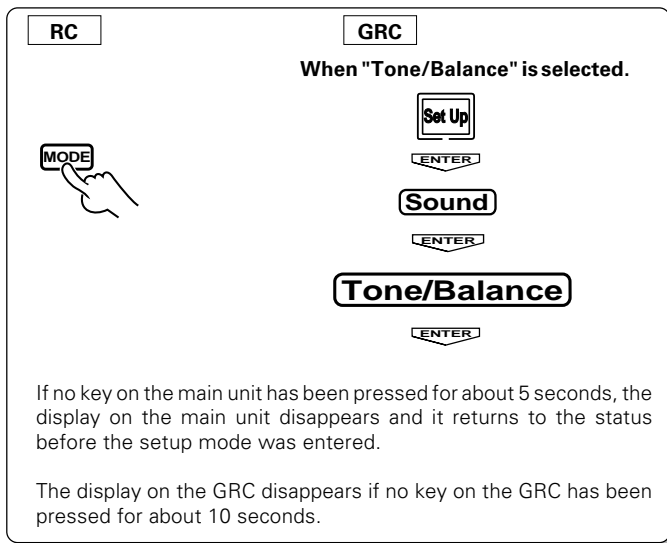

#### RC/Main unit

Each press switches the adjustment items as shown below.

- ① **BASS** :Tone, Bass
- ② **TREBLE** :Tone, Treble
- ③ **L- - - - -R** :Balance
- ④ **C ch** :Center speaker
- ⑤ **SR ch** :Surround speaker, Right
- ⑥ **SL ch** :Surround speaker, Left
- ⑦ **SW ch** :Subwoofer
- ⑧ **DELAY** :Delay time
- ⑨ **INPUT** :Input level

- Adjustment items ⑤, ⑥ and ⑧ are not required in the 3 STEREO mode.
- With the GRC, the adjustment items shown in a single menu can be adjusted at once. (The adjustment steps ①, ② and ③ or steps ④, ⑤, ⑥ and ⑦ are provided in a single menu so they can be adjusted successively without changing the menu screen.)

#### GRC

When "Tone/Balance" is selected.

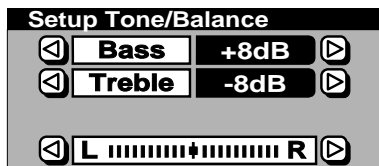

When "Speaker Level" is selected.









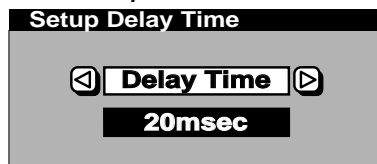



When "Input Level" is selected.



When "Delay Time" is selected.









### 3 Adjust the Bass tone level. "BASS"

RC	GRC
<p>1 Select "BASS".</p> 	<p>1 Set to "Set Up Sound" mode.</p>  
<p>2 Adjust the level as required.</p> <p>To increase</p>  <p>LEVEL</p>  <p>To decrease</p>	<p>2 Select the "Tone/Balance".</p> <div style="text-align: center;">    </div> <p>3 Adjust the level as required.</p> <div style="text-align: center;">  <span style="border: 1px solid black; padding: 2px;">Bass</span> <span style="border: 1px solid black; padding: 2px;">+8dB</span>  </div> <p>To decrease <span style="margin-left: 100px;">To increase</span></p> 







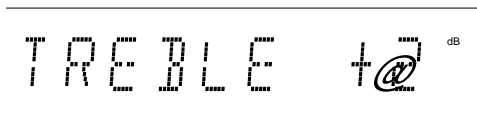

### 4 Adjust the Treble tone level. "TREBLE"

RC	GRC
<p>1 Select "TREBLE".</p> 	<p>1 Confirm the display.</p> <p>(Select icon as required.)</p>
<p>2 Adjust the level as required.</p> <p>To increase</p>  <p>LEVEL</p>  <p>To decrease</p>	<p>2 Adjust the level as required.</p> <div style="text-align: center;">  <span style="border: 1px solid black; padding: 2px;">Treble</span> <span style="border: 1px solid black; padding: 2px;">-8dB</span>  </div> <p>To decrease <span style="margin-left: 100px;">To increase</span></p> 







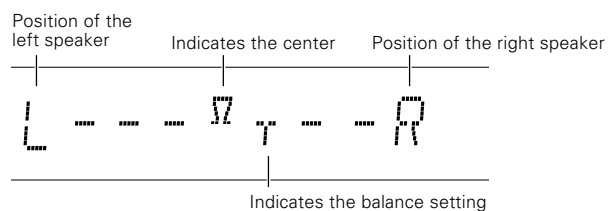





### 5 Adjust the balance. "L-----R"

RC	GRC
<p>1 Select "L-----R".</p> 	<p>1 Confirm the display.</p> <p>(Select icon as required.)</p>
<p>2 Adjust the levels of the front speakers (Left, Right) so that they sound identical.</p> <p>To decrease left channel level</p>  <p>LEVEL</p>  <p>To decrease right channel level</p>	<p>2 Adjust the levels of the front speakers (Left, Right) so that they sound identical.</p> <div style="text-align: center;">  <span style="border: 1px solid black; padding: 2px;">L</span>  <span style="border: 1px solid black; padding: 2px;">R</span>  </div> <p>To decrease right channel level <span style="margin-left: 100px;">To decrease left channel level</span></p> 













### 6 Adjust the center speaker level. "Cch"

RC	GRC
<p>1 Select "Cch".</p> 	<p>1 Set to "Set Up Sound" mode.</p>  
<p>2 Adjust the level as required.</p> <p>To increase</p>   <p>To decrease</p>  	<p>2 Select the "Speaker Level".</p> <p><b>Speaker Level</b></p> 
	<p>3 Adjust the level as required.</p>  <b>Center</b>  <b>+10dB</b> <p>To decrease To increase</p> 









Cch +2<sup>dB</sup>

### 7 Adjust the right surround speaker level. "SRch"

RC	GRC
<p>1 Select "SRch".</p> 	<p>1 Confirm the display.</p> <p>(Select icon as required.)</p>
<p>2 Adjust the level as required.</p> <p>To increase</p>   <p>To decrease</p>  	<p>2 Adjust the level as required.</p>  <b>Surr.R</b>  <b>-5dB</b> <p>To decrease To increase</p> 

SRch +1<sup>dB</sup>

### 8 Adjust the left surround speaker level. "SLch"

RC	GRC
<p>1 Select "SLch".</p> 	<p>1 Confirm the display.</p> <p>(Select icon as required.)</p>
<p>2 Adjust the level as required.</p> <p>To increase</p>   <p>To decrease</p>  	<p>2 Adjust the level as required.</p>  <b>Surr.L</b>  <b>-10dB</b> <p>To decrease To increase</p> 

SLch +1<sup>dB</sup>

### 9 Adjust the subwoofer level. "SWch"

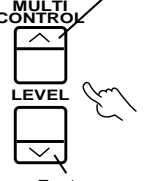
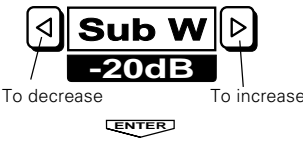
<p><b>RC</b></p> <p>1 Select "SWch".</p>  <p>2 Adjust the level as required.</p> <p>To increase</p>  <p>To decrease</p>	<p><b>GRC</b></p> <p>1 Confirm the Subwoofer adjustment display.</p> <p>(Select icon as required.)</p> <p>2 Adjust the level as required.</p>  <p>To decrease      To increase</p>
---	---

### To skip an adjustment item

**RC/Main unit**

- When an adjustment item is not required to be adjusted, press the **MODE** key to go to the next adjustment step.



**GRC**

- Select only the icons of the adjustment items which require adjustment.

SWch + 10 dB

- The level can be adjusted between -20 and +10 dB in steps of 1 dB.

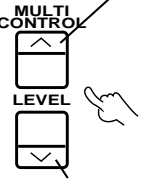
### 10 Adjust the delay time. "DELAY"



<p><b>RC</b></p> <p>1 Select "DELAY".</p>  <p>2 Adjust the level as required.</p> <p>To increase</p>  <p>To decrease</p>	<p><b>GRC</b></p> <p>1 Set to "Set Up Sound" mode.</p>  <p>2 Select the "Delay Time".</p> <p><b>Delay Time</b></p> <p>3 Adjust the delay time.</p>  <p>To decrease      To increase</p>
--	--

- Find the optimum delay time for the listening room by referring to "How to calculate the delay time". → 37
- The delay time in the PRO LOGIC mode can be adjusted between 15 and 30 ms.
- Select the closest value to the value obtained by "How to calculate the delay time".

DELAY 20 ms

Delay time

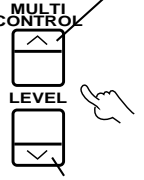
### 11 Adjust the input level. "INPUT"

<p><b>RC</b></p> <p>1 Select "INPUT".</p>  <p>2 Adjust the level as required.</p> <p>To increase</p>  <p>To decrease</p>	<p><b>GRC</b></p> <p>1 Set to "Set Up Sound" mode.</p>  <p>2 Select the "Input Level".</p> <p>3 Set the input level.</p> <p><b>Input Level -6dB</b></p> <p>Each press changes the level.</p>
--	---

If the input level is too high, set it to -6 dB to avoid sound distortion.

- The input level can be set to -6 dB or 0 dB.
- This adjustment is not available with 6ch INPUT.

INPUT @@@ dB

### To quit the setup operation:

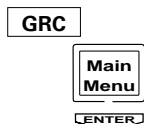

- If no key on the main unit has been pressed for about 5 seconds, the display on the main unit disappears and it returns to the status before the setup mode was entered.
- The display on the GRC disappears if no key on the GRC has been pressed for about 10 seconds.

# Setup of the surround effect parameters (DSP)

## 1 Select the DSP surround mode.

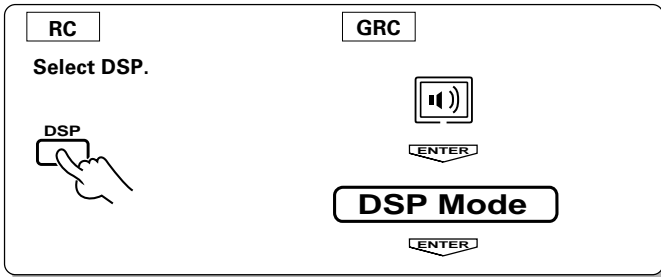

- RC/Main unit**
- Each press switches the indication.
- ① ARENA
  - ② JAZZ CLUB
  - ③ STADIUM

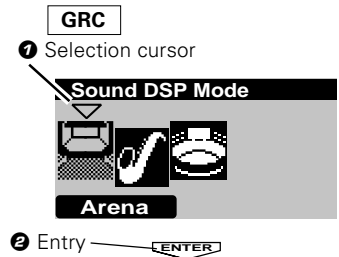

- The effects of adjustments are applied equally to sound fields ① to ③.
- Switching is not possible when the 6ch INPUT is used.

## 2 Select the adjustment parameter.

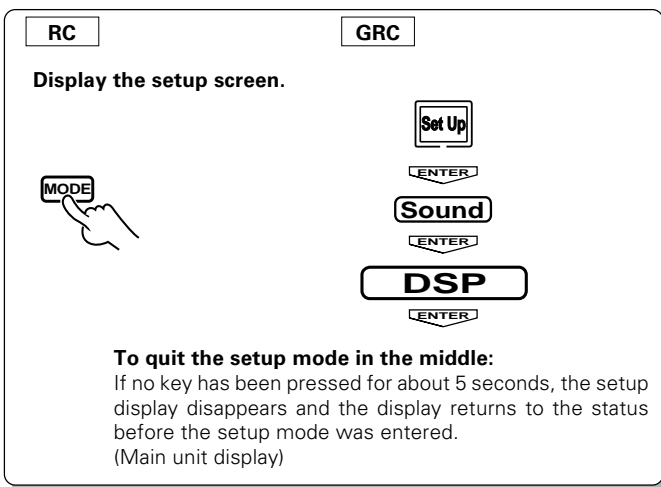

- RC/Main unit**
- Each press switches the adjustment parameters.
- ① EFFECT
  - ② BASS
  - ③ TREBLE
  - ④ L- - - - -R
  - ⑤ SRch
  - ⑥ SLch
  - ⑦ SWch
  - ⑧ INPUT

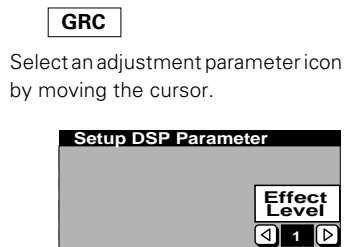

- Setup/adjustment operations ② to ⑧ are to be performed only when required.

## 3 Adjust the effect level. "EFFECT"

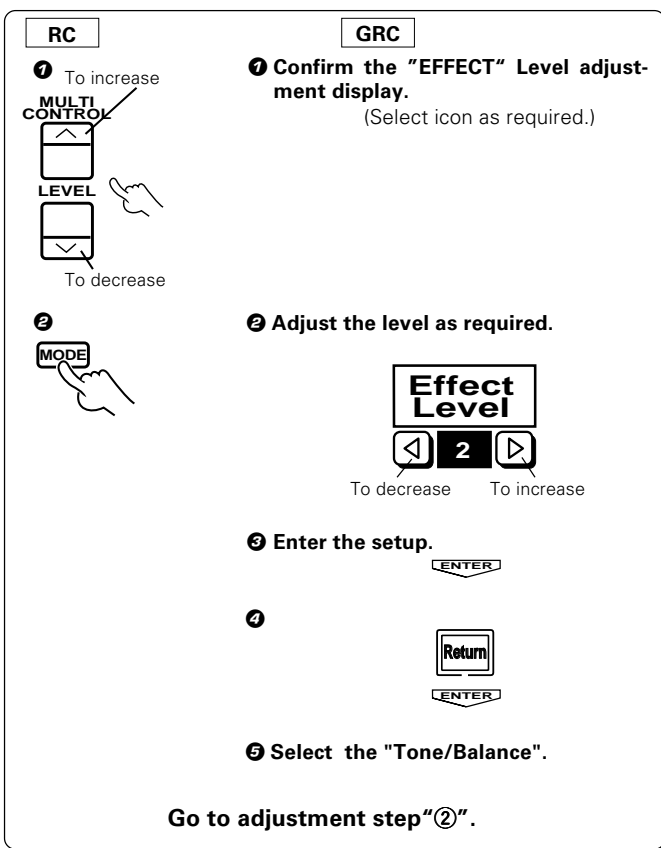

- The EFFECT level can be adjusted between 1 ~ 5.

**To quit the setup mode in the middle:**

If no key has been pressed for about 5 seconds, the setup display disappears and the display returns to the status before the setup mode was entered.

- Setup/adjustment operations ② to ⑧ are to be performed only when required.  
The operations are identical to those in "Setup for surround play (while listening to music)".

→ 39

**To return the GRC display to the Main menu:**

GRC

Main  
Menu

ENTER

- If no key on the main unit has been pressed for about 5 seconds, the display on the main unit disappears and it returns to the status before the setup mode was entered.
- The display on the GRC disappears if no key on the GRC has been pressed for about 10 seconds.

# Clock adjustment

This unit incorporates a clock function. Be sure to adjust the correct time before using the timer function.

The time display blinks after a power failure or when the power cord has been unplugged from the AC outlet and plugged in again. In such a case, adjust the clock again.

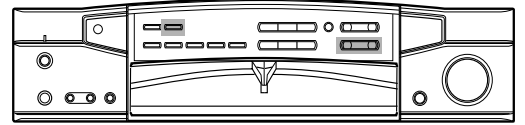

 : Keys or controls to be used in this operation

## 1 Activate the clock adjustment mode.

**Main unit**

Press the **CLOCK** key.



## 2 Enter the hour.

**Main unit**

1 Set the "hour".

PTY SELECT



To decrease the figure      To increase the figure

2 Press the **CLOCK** key.

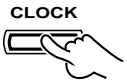

## 3 Enter the minute.

**Main unit**

1 Set the "minute".

PTY SELECT



To decrease the figure      To increase the figure

2 Press the **CLOCK** key.

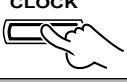

Example: Adjustment to 8:15

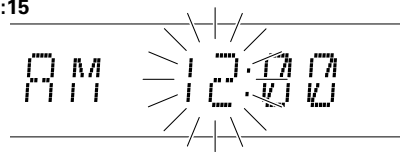

- The time display starts to blink.

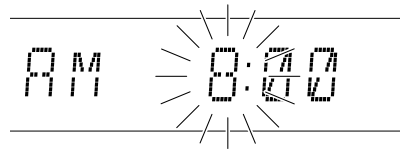

- The time is represented in 12-hour AM/PM method.
- Press the **CLOCK** key. The hour is entered and the minute display starts to blink.

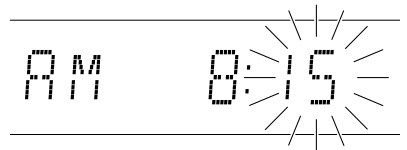

- If you make a mistake, restart from the beginning.
- To adjust correct time, press the **CLOCK** key at the same moment as a time announcement.

# Displaying the Time

RC      GRC

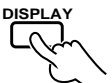

Main Menu

ENTER

Main Menu

ENTER

**Display**

ENTER

Each press switches the indication.

- 1 Input selection display
- 2 DOLBY/DSP/STEREO display
- 3 Clock display (about 5 seconds)

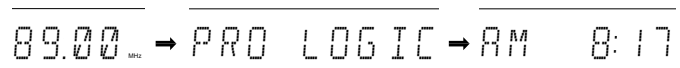

# Timer operation

Two 24-hour timer systems (TIMER 1, TIMER 2) (which can be used every day) and a sleep timer system (which works only once) are available.

In each of TIMER 1 and TIMER 2, the timer data including the operating period and played contents can be set and selected to be activated or not as required.

**Timer reservation is possible for the two types TIMER 1 and TIMER 2 at the same time.**

- Please make reservations with an interval of at least one minute, so that the operation times of TIMER 1 and TIMER 2 do not overlap.

## Timer playback, timer recording (TIMER 1, TIMER 2)

With each of the two timer programs, a selected source can be played (or radio broadcast can be recorded) in the previously set time period.

## Sleep timer

The unit is put to STANDBY mode automatically after the specified period has elapsed.



# Timer programming

## 1 Make preparations for the play (recording).

- To listen to radio

The station should be preset before timer programming. - 28 - 29

- To listen to CD/LD/MD /DVD

Insert a disc. (Program playback is not possible.)

- To listen to tape

Insert a tape.

- For broadcast recordings

Make preparations for recording. - 25

If tapes are inserted in both decks A and B, playback starts with the tape in deck B.

## 2 Adjust the listening volume.

Main unit

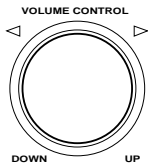

- The **VOLUME CONTROL** should be set to the desired volume while the unit is ON.

## 3 Set the I / ⏻ (ON/STANDBY) switch to STANDBY.

Main unit



## 4 Select a TIMER No.

Main unit

- 1 Select the timer number.



- 2 Press immediately after selection.

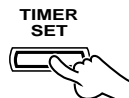

Each press of the key switches the **TIMER** numbers as follows.

- 1 **TIMER 1**
- 2 **TIMER 2**
- 3 **TIMER 1,2**
- 4 **OFF**

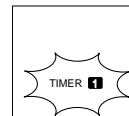

- The selected TIMER No. lights.
- If a previously programmed TIMER No. is selected, the contents will be replaced by the new contents programmed.
- The timer programming operation is not possible when TIMER 1,2 have already been selected.

### 5 Enter the ON time (Hour).

**Main unit**

① Set the "hour".

PTY SELECT  
  
 To decrease the figure    To increase the figure

② Enter it.

TIMER SET  

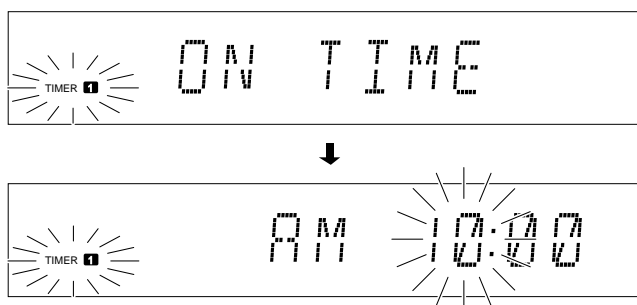



### 6 Enter the On time (Minute).

**Main unit**

① Set the "minute".

PTY SELECT  
  
 To decrease the figure    To increase the figure

② Enter it.

TIMER SET  

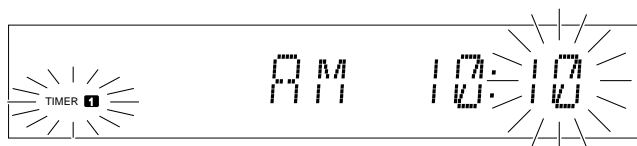

- After entering the figure of "hour" with the procedure in step 5, enter the figure of "minute" using the same procedure.

### 7 Enter the OFF time (Hour).

**Main unit**

① Set the "hour".

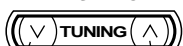
PTY SELECT  
  
 To decrease the figure    To increase the figure

② Enter it.

TIMER SET  

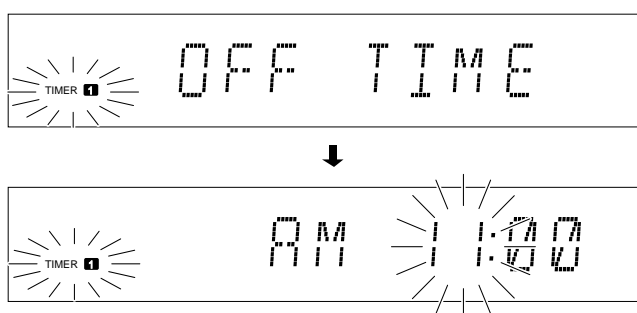



### 8 Enter the OFF time (Minute).

**Main unit**

① Set the "minute".

PTY SELECT  
  
 To decrease the figure    To increase the figure

② Enter it.

TIMER SET  

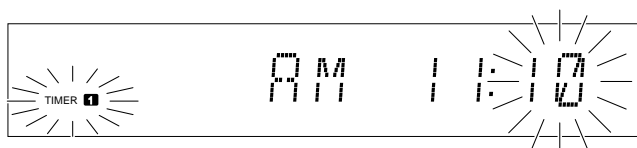

- After entering the figure of "hour" with the procedure in step 7, enter the figure of "minute" using the same procedure.

## 9 Make the desired reservation.

### For timer playback

**Main unit**

**1 Select the mode.**

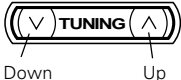
PTY SELECT  
  
 Down Up

**1 Select "PLAY"**  
 (Each press alternates them.)  
 → **PLAY** : At the ON time, playback starts.  
 → **REC**

**2 Enter it.**

TIMER SET  

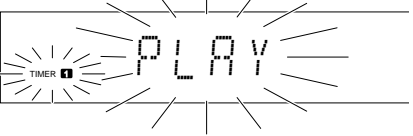

---

**2 Select the input source.**

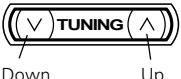
PTY SELECT  
  
 Down Up

**1 Select the source to be played.**  
 (Each press switches the following.)

→ **TUNER**  
 → **CD**  
 → **LD / DVD**  
 → **TAPE1 / MD**  
 → **6ch INPUT**

**2 Enter it.**

TIMER SET  

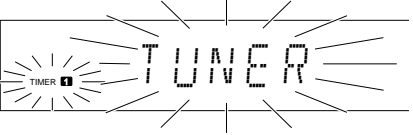

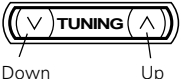

---

**3 Select the broadcast station (only when TUNER is selected above).**

PTY SELECT  
  
 Down Up

**1 Select the preset station No.**

**2 Enter it.**

TIMER SET  

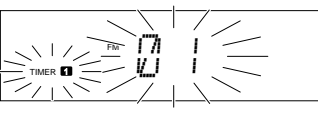

- The station to be received with timer must be preset beforehand. — 28 — 29
- If you make a mistake, restart from step 1.

### Timer recording of broadcasts

**Main unit**

**1 Select the mode.**

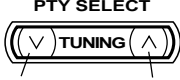
PTY SELECT  
  
 Down Up

**1 Select "REC".**  
 (Each press alternates them.)  
 → **PLAY**  
 → **REC**

**2 Enter it.**

TIMER SET  

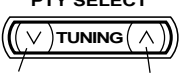

---

**2 Select the broadcast station.**

PTY SELECT  
  
 Down Up

**1 Select the preset station No.**

**2 Enter it.**

TIMER SET  

## Activating the timer

### Select the TIMER No. to be used.

**Main unit**

TIMER MODE  

Each press of the key switches the **TIMER** numbers as follows.

- ① **TIMER 1** ..... Execution of timer 1 only.
- ② **TIMER 2** ..... Execution of timer 2 only.
- ③ **TIMER 1, 2** .. Execution of timers 1 and 2.
- ④ **TIMER OFF**

- The selected **TIMER No.** lights.
- The timer will not function unless a **TIMER No.** is selected.



The reservation contents cannot be cleared. The contents are cleared only when they are changed.

### Check the reservation content.

**Main unit**

Select the **TIMER** number to be checked.

Each press of the key switches the **TIMER** numbers as follows.

- ① **TIMER 1** (Contents of the timer 1 are displayed.)
- ② **TIMER 2** (Contents of the timer 2 are displayed.)
- ③ **TIMER 1, 2** (Contents of the timer 1 and timer 2 are displayed.)
- ④ **TIMER OFF**

- The reserved contents will be displayed for 2 seconds per item. After this, the previous display content appears again.

### To change the reserved contents

Restart the procedure of "Timer programming" from the beginning.

### When timer operation is not required

**Main unit**

Press so that all **TIMER No.** indicators are **OFF**.

Each press of the key switches the **TIMER** numbers as follows.

- ① **TIMER 1** (Only the timer 1 is carried out.)
- ② **TIMER 2** (Only the timer 2 is carried out.)
- ③ **TIMER 1, 2** (Both timers 1 and 2 are carried out.)
- ④ **TIMER OFF** (No timer operation is carried out.)

- The reservation contents are held in memory.

### To set the same timer program again

**Main unit**

Press so that the desired **TIMER No.** indicators light.

Each press of the key switches the **TIMER** numbers as follows.

- ① **TIMER 1** (Only the timer 1 is carried out.)
- ② **TIMER 2** (Only the timer 2 is carried out.)
- ③ **TIMER 1, 2** (Both timers 1 and 2 are carried out.)
- ④ **TIMER OFF** (No timer operation is carried out.)

- Also prepare the disc or tape and adjust the listening volume.

## Sleep timer

### Setting the number of minutes until the unit is put to standby mode.

**Main unit**      **GRC**

① Switch the unit from **STANDBY** mode to **ON** mode.

② Set the time.

**RC**

**Main Menu**  
ENTER  
**Main Menu**  
ENTER  
**Sleep**  
ENTER

- This unit is turned **STANDBY** automatically after the set time has elapsed.
- The remaining sleep time can be displayed by selecting the Sleep icon while the **SLEEP** indicator is lit.

- Each press decreases the time by 10 minutes. The maximum time that can be set is 90 minutes.

90→80→70...30→20→10→Cancel→90→80...

SLEEP 90

SLEEP

Duration for sleep timer.

Lights up.

### To cancel

Turn **STANDBY** or select "Sleep" icon repeatedly until the sleep time is cancelled.

# Set up code chart

C-V351/C-V301 (EN)

## 50 VCR Set up codes

Maker	Set up codes
AIWA	015,322,367
AKAI	056,121,330
AKIBA	087
ALBA	035,224,293,310,367
AMBASSADOR	035
AMSTRAD	015,340,347
ANITECH	087
ASA	052,096
ASUKA	052
BAIRD	015,056,119,122
BASIC LINE	035,087,293
BLAUPUNKT	021,049,177,210,241
BRANDT	202,335
BRANDT ELECTRONIQUE	056
BUSH	087,224,293,367
CATRON	035
CGE	015
CIMLINE	087
CLATRONIC	035
COMBITECH	367
CONDOR	035
CROWN	035,087,293
DAEWOO	035,293
DANSAI	087
DE GRAAF	057
DECCA	015,096
DUAL	056
DUMONT	015,096,119
ELCATECH	087
ESC	255,293
FERGUSON	056,122,335
FIDELITY	015
FINLANDIA	096,119
FINLUX	015,057,096,119
FIRSTLINE	052,058,060,087,224
FISHER	061,119
FRONTECH	035
FUNAI	015
GEC	096
GENERAL	035
GOLDSTAR	052
GOODMANS	015,035,052,087,293
GRAETZ	056,119,255
GRANADA	061,096,119
GRANDIN	015,052,087
GRUNDIG	021,022,087,096,210,241,362
HANSEATIC	052
HCM	087
HINARI	087,223,255,367
HITACHI	015,056,057,255

Maker	Set up codes
HYPSON	087
IMPERIAL	015
INTERFUNK	096
ITT	056,061,119,121,255,399
ITV	052,293
JVC	056,082,221,399
KAISUI	087
KENDO	121,224
KENWOOD	056
KORPEL	087
LENCO	293
LEYCO	087
LOEWE	021,052,096
LOGIK	255
LUXOR	058,061,119,121
M-ELECTRONIC	015
MANESTH	060,087
MARANTZ	021,096,310
MATSUI	223,224,310,367
MEMOREX	015,052,061,119
MEMPHIS	087
METZ	021,177,210,362
MINERVA	210
MITSUBISHI	058,082,096
MULTITECH	015,087
MURPHY	015
NEC	056,082
NECKERMANN	096
NESCO	087
NOKIA	056,061,119,121,255
NORDMENDE	056,399
OCEANIC	015,056
OKANO	330
ORION	223,224,310,367
OSAKI	015,052,087
OTTO VERSAND	096
PALLADIUM	021,052,056,087
PANASONIC	177,240,241
PATHE MARCONI	056
PENTAX	057
PERDIO	015
PHILIPS	096,399
PHONOLA	096
PIONEER	082,096
PORTLAND	035
PROFEX	337
PROFITRONIC	255
PROLINE	015
PYE	096
QUARTZ	061

Maker	Set up codes
QUELLE	096
RADIOLA	096
REX	056,399
ROADSTAR	052,087,255,293
SABA	056,221,335,399
SAISHO	223,224
SALORA	058,061,121
SAMSUNG	255,447
SANSUI	056,082
SANYO	061,119
SAVILLE	367
SBR	096
SCHAUB LORENZ	015,056
SCHNEIDER	015,087,096
SEG	255,337
SEI	096
SELECO	056
SENTRA	035
SHARP	063
SHINTOM	087,119
SIEMENS	021,052,119,210
SILVA	052
SINGER	060
SINUDYNE	096
SOLAVOX	035
SONTEC	052
SONY	047,048,049
SUNSTAR	015
SUNTRONIC	015
TASHIKO	015
TATUNG	015,056,096
TEC	035
TECHNICS	177
TELEAVIA	056
TELEFUNKEN	056,202,335,399
TENOSAL	087
TENSAI	015,337
THOMSON	056,335,399
THORN	056,119
TOSHIBA	056,058,060,096,399
TOWADA	337
TRIUMPH	223
UHER	255
UNIVERSUM	015,021,052,096,121,210,255,340
YAMISHI	087
YOKAN	087
YOKO	035,255

## TV Set up codes

Maker	Set up codes
ACURA	024
ADMIRAL	102,178
ADYSON	232
AGB	531
AKAI	223,366,376
AKURA	233
ALBA	024,052,233,250
ALLOGRAN	309
AMPLIVISION	232
AMSTRAD	024,192,386,531
ANITECH	024
ARC EN CIEL	516
ARCAM	231,232
ASA	102,119
ASUKA	233
AUDIOSONIC	052,124
AUTOVOX	102
BAIRD	358
BANG&OLUFSEN	102
BASIC LINE	024,233
BAUR	025,052,376,520,569
BEKO	385
BEON	052
BINATONE	232
BLAUPUNKT	206,342,343,569
BLUE SKY	233
BLUE STAR	297
BONDSTEC	262
BOOTS	232
BPL	297
BRANDT	124,211,348,350
BRANDT ELECTRONIC	516
BRIONVEGA	102
BRITANNIA	231
BRUNS	102
BSR	309
BTC	233
BUSH	024,051,052,233,297, 370,386,389,539,558, 567
CARREFOUR	051
CASCADE	024
CATHAY	052
CENTURION	052
CENTURY	102
CGE	262,567
CIMLINE	024
CLARIVOX	052
CLATRONIC	262,385
CONDOR	335,385

Maker	Set up codes
CONTEC	024,051,231
CONTINENTAL EDISON	211,348,414,516
CROSLLEY	102
CROWN	024,385,433
CRYSTAL	446
CS ELECTRONICS	231
CTC	262
CYBERTRON	233
DAEWOO	024,052,389
DAINICHI	233
DANSAI	052
DAYTON	024
DE GRAAF	223,558
DECCA	052,087,264,531
DIXI	024,052
DUAL	367
DUAL TEC	232
DUMONT	085,102
ELBE	274
ELIN	052
ELITE	233,335
ELTA	024
EMERSON	102,376
ERRES	027,052
EUROPHON	531
FERGUSON	052,088,124,302,350,358
FIDELITY	231
FINLANDIA	223,361,374
FINLUX	052,085,087,102,119, 120,361,426,531
FIRSTLINE	024,231,232,262,309,336
FISHER	119,223,232,385
FLINT	470
FORMENTI	052,102,335,567
FRONTECH	178,262,279,446,558
FUJITSU	087
FUNAI	279,309
GBC	567
GEC	052,058,087,232,531,572
GELOSO	024
GENEXXA	178,233
GOLDSTAR	052,124,232,558
GOODMANS	051,052,087,250,358,386,389
GENEXXA	178,233
GORENJE	385
GPM	233
GRAETZ	178,362,376,572
GRANADA	052,087,223,232,366, 374,531,558
GRANDIN	297

Maker	Set up codes
GRUNDIG	085,206,569
HANSEATIC	052,335,376,443
HANTAREX	531
HCM	024,297
HIFIVOX	516
HINARI	024,051,052,233
HISAWA	297,470
HITACHI	051,058,059,120,124, 178,211,232,240, 362,371,558,572
HUANYU	231,389
HYPSON	052,279,297
ICE	232,279,386
IMPERIAL	262,385,433,539,567
INDIANA	052
INGELEN	178,572
INNO HIT	087,531
INTERFUNK	052,178,262,376,516,572
INTERVISION	117,232,279
ISUKAI	233
ITC	567
ITS	386
ITT	178,362,366,376,572
JEC	050
JVC	051,068,109
KAISUI	024,231,232,233,297
KAPSCH	178,572
KENNEDY	567
KINGSLEY	231
KNEISSEL	274
KORPEL	052
KORTING	102
KOYODA	024
LEYCO	052,087,279,309
LIESENK&TTER	052
LOEWE	102
LUXOR	371,372,376,558
M ELECTRONIC	024,119,120,178,361,389
M-ELECTRONIC	052,124,232,302
MAGNADYNE	102,117,262,531
MAGNAFON	117,531
MANESTH	232,250,279,335
MARANTZ	052
MARELLI	102
MARK	052
MATSUI	024,026,050,051,052, 087,192,250,309,370, 386,531,539,558
McMICHAEL	058
MEDIATOR	027,052
MEMOREX	024

52 **TV Set up codes**

Maker	Set up codes
MEMPHIS	352
METZ	102,254,382,403,462
MINERVA	085,569
MITSUBISHI	051,102,123,165
MIVAR	231,531
MULTITECH	024,117,231,558
NECKERMANN	052,102,206,520,569
NEI	052,352,446
NIKKAI	050,052,087,231,233,279,352
NOBLIKO	117
NOGAMATIC	516
NOKIA	376
NORDMENDE	124,211,302,358,516
OCEANIC	178,362,376
ORION	052,192,250,309,335,336,370,531
OSAKI	087,232,233,279
OSO	233
OSUME	087
OTTO VERSAND	051,052,206,232,335,520,567,569
OTTO-VERSAND	025,358
PALLADIUM	385
PANAMA	232,279
PANASONIC	141,178,241,265,362,382,572
PATHE CINEMA	231,335,567
PATHE MARCONI	211,348,516
PAUSA	024
PERDIO	335
PHILCO	102,262,567
PHILIPS	027,052,058,102,338,389,569
PHOENIX	102
PHONOLA	027,052,102
PIONEER	124,178,302
PRANDONI-PRIN	531
PROFEX	024,376
PROLINE	336
PROTECH	024,052,117,232,262,279,352,446,567
PYE	027
QUELLE	025,026,052,085,119,267,342,343,376,520,567,569
QUESTA	051
R-LINE	052
RADIOLA	027,052,338
RADIOMARELLI	102,531
RBM	085
RCA	105
REDIFFUSION	376

Maker	Set up codes
REX	178,274,279
RFT	102,443
ROADSTAR	024,233,279
SABA	102,124,178,211,302,350,358,362,516,572
SAISHO	024,026,192,250,279,531
SALORA	178,371,374,376,558
SAMBERS	117,531
SAMSUNG	024,052,232,279,385
SANDRA	231
SANYO	026,051,087,119,223
SBR	027,052,058
SCHAUB LORENZ	362,376,572
SCHNEIDER	052,233,262,338,367,386,409
SEG	051,232,279,567
SEI	102,117,192,309
SEI-SINUDYNE	025,531
SELECO	178,274,426
SENTRA	050
SHARP	051,108
SHORAI	309
SIAREM	102,117,531
SIEMENS	206,342,343,569
SILVER	051
SINGER	102
SINUDYNE	102,117,192,250,309
SKANTIC	371,372
SOLAVOX	178
SONITRON	223
SONOKO	024,052
SONOLOR	178,223
SONTEC	052
SONY	025,026,051,520
SOUNDWAVE	052
STANDARD	024,232,233
STERN	178,274
SUNKAI	309,336,370
SUSUMU	233
SYSLINE	052
TANDY	087,178,232,233
TASHIKO	051,058,232,558
TATUNG	052,087,232,264,531
TEC	232,262,567
TECHNEMA	335
TECHNICS	265
TELEAVIA	348,358,516
TELEFUNKEN	116,124,267,277,350,358,486,516
TELEMEISTER	335

Maker	Set up codes
TELETECH	024
TELETON	232
TENSAI	233,309,335
THOMSON	124,211,302,348,358,414,516
THORN	050,052,087,119,376,520
THORN-FERGUSON	358
TOMASHI	297
TOSHIBA	050,051,085
TOWADA	567
TRIUMPH	192,531
UHER	335
ULTRAVOX	117,366
UNIVERSUM	052,119,120,279,361,385,436,567
VESTEL	052
VIDEOSAT	262
VISION	335
VOXSON	102,178
WALTHAM	232,371
WATSON	052,335
WATT RADIO	117,567
WEGA	051,102
WHITE WESTINGHOUSE	052,231,335
YOKO	052,232,279,446

**LD Set up codes**

Maker	Set up codes
DENON	187
KENWOOD	273
MAGNAVOX	232
MARANTZ	079
PHILIPS	079
PIONEER	074
SALORA	079
SONY	208,216
TELEFUNKEN	074
YAMAHA	232

**Satellite Set up codes**

Maker	Set up codes
ALBA	106,269,377,436,470
ALDES	303
ALLANTIDE	348
AMSTRAD	095,228,267,360,476,524
ANKARO	232,235,303,384
ANTTRON	198,436
AST	336
ASTRA	123
ASTRO	188,373
AUDIOTON	379
AXIS	381,384,545
BARCOM	232
BEST	232,384
BLAUPUNKT	188
BRAIN WAVE	347
BUSH	082,106,269
CAMBRIDGE	271,359
CHANNEL MASTER	377
COMMLINK	303
CONNEXIONS	411,473
CONTEC	381
DDC	377
DISKXPRESS	232
DNT	215,411,473
ECHOSTAR	411
ELTA	379
EMANON	436
FERGUSON	082,198,351
FIDELITY	267
FINLUX	123,359,470
FREECOM	350,436
FTE	346
FUBA	187,232,312,313,384,411,436
G-SAT	198
GALAXIS	303,379,381
GALAXISAT	336
GOLDSTAR	350
GROTHUSEN	350
GRUNDIG	188,343
HARTING UND HELLING	348
HINARI	198
HIRSCHMANN	188,348,412,510
HUTH	235,303,361,379
IMPERIAL	269
INTERVISION	607
ITT	123,187
JOHANSSON	347
JSR	379
KATHREIN	107,188,215,346,373,409,457,519

Maker	Set up codes
KOSMOS	346,350
KREISELMEYER	188
KYOSTAR	436
LENCO	350,436
LUPUS	384
LUXOR	123,187
MANHATTAN	470,607
MARANTZ	215
MASPRO	107,343,351,510
MATSUI	359
MICRO TECHNOLOGY	348
MULTISTAR	346
MURATTO	350
NAVEX	347
NEUHAUS	235
NOKIA	123,187,343,412,470
NORDMENDE	377
ORBITECH	516
OXFORD	359
PACE	082,198,343,351,470
PALCOM	312,313
PANDA	470
PHILIPS	215,343,470
PHOENIX	381
PHONOTREND	303,607
POLYTRON	409
PROMAX	470
PROSAT	303
PTT-TELECOM	228
QUADRAL	377
RADIOLA	215
RADIX	411
RCA	581
RFT	215,235,303
SABA	269,351
SABRE	470
SAKURA	381
SALORA	123,187
SAT	336,476
SATCOM	228,361
SATEC	198,343
SATMASTER	361
SATPARTNER	347,350,436
SCHWAIGER	198,409,519
SEEMANN	411,545
SEG	384,436
SIEMENS	188
SKYMASTER	303
TANTEC	312,313,351,470
TECHNILAND	361

Maker	Set up codes
TECHNISAT	277,473,516
TELEFUNKEN	436
THOMSON	470
TONNA	361
TRIAD	336,348,350
UNISAT	381
UNITOR	232,347
UNIVERSUM	188
VECTOR	348
VENTANA	215
VORTEC	436
VTECH	336
WEVASAT	348
WINERSAT	347
WISI	188,336,411,470
ZEHNDER	336,346

**Cable Set up codes**

Maker	Set up codes
BRITISH TELECOM	120
CABLETIME	286
DECSAT	438
FILMNET	458
FRANCE TELECOM	466
JERROLD	018
PIONEER	159
PVP STEREO VISUAL MATRIX	018
SALORA	397
SATBOX	390
SCIENTIFIC ATLANTA	023,292
TELE+1	458
UNITED CABLE	018
WESTMINSTER	120

What appears to be a malfunction may not always be serious. If your unit should not perform as expected, consult the table below to see if the problem can corrected before seeking help from your dealer or service representative.







## How to reset the microcomputer

The microcomputer may malfunction (impossibility of operation, erroneous display, etc.) when the power cord is unplugged and plugged in again while the unit is in ON mode with the I/⏻ key pressed or due to other external causes. In this case, execute the procedure on the right to reset the microcomputer and return the unit to the normal condition.





- ① Unplug the power cord from the wall outlet.
- ② While holding the I/⏻ (ON/STANDBY) key depressed, plug the power cord into the wall outlet again.

- Resetting the microcomputer clears the memory you entered and returns it to the initial condition when the unit left the factory.

## Amplifier

Symptom	Cause	Remedy
Sound is not output or the volume level is low.	<ul style="list-style-type: none"> <li>● Connection cords are unplugged from the jacks.</li> <li>● MUTE is ON. (The MUTE ON indicator is blinking)</li> <li>● The <b>TAPE 2 (MONITOR)</b> key is set to ON.</li> </ul>	<ul style="list-style-type: none"> <li>● Connect them properly referring to "System connection".  </li> <li>● Press the <b>MUTE</b> key to OFF. </li> <li>● Set the <b>TAPE 2 (MONITOR)</b> key to OFF.</li> </ul>
"PROTECT" blinks and sound is not output.	<ul style="list-style-type: none"> <li>● Speaker cords are short-circuited.</li> </ul>	<ul style="list-style-type: none"> <li>● Unplug the AC cord, remove the short-circuiting and plug the AC cord again.</li> </ul>
Sound is not output from one of the speakers.	<ul style="list-style-type: none"> <li>● The BALANCE control is set to an extreme position.</li> </ul>	<ul style="list-style-type: none"> <li>● Adjust the Left/Right balance. </li> </ul>
Sound is not output from the surround speaker and/or center speaker, or their sound is very small.	<ul style="list-style-type: none"> <li>● The surround speaker cords and/or center speaker cord are disconnected.</li> <li>● The Surround play mode has not been engaged.</li> <li>● The surround and center speaker levels are set to the minimum positions.</li> </ul>	<ul style="list-style-type: none"> <li>● Connect them by referring to the power amplifier's instruction manual.</li> <li>● Set the presence mode. </li> <li>● Adjust the surround and center speaker levels.</li> </ul>
System control is not available when TAPE1 or MD is selected.	<ul style="list-style-type: none"> <li>● "TAPE1" or "MD" is not displayed.</li> </ul>	<ul style="list-style-type: none"> <li>● Switch the display to "TAPE 1" or "MD". </li> </ul>
System control is not available when LD or DVD is selected.	<ul style="list-style-type: none"> <li>● "LD" or "DVD" is not displayed.</li> </ul>	<ul style="list-style-type: none"> <li>● Switch the display to show "LD" or "DVD". </li> </ul>
System control is impossible.	<ul style="list-style-type: none"> <li>● System control cords are connected incorrectly.</li> </ul>	<ul style="list-style-type: none"> <li>● Connect them correctly by referring to "System connection".</li> </ul>

## Tuner

Symptom	Cause	Remedy
Radio stations cannot be received.	<ul style="list-style-type: none"> <li>● No antenna is connected.</li> <li>● The broadcast band is not set properly.</li> <li>● The frequency of the desired station is not tuned.</li> </ul>	<ul style="list-style-type: none"> <li>● Connect an antenna. </li> <li>● Set the broadcast band properly. </li> <li>● Tune the frequency of the desired station. </li> </ul>
Interference.	<ul style="list-style-type: none"> <li>● Noise due to ignition noise of an automobile.</li> <li>● Noise due to an influence from an electric appliance.</li> <li>● Noise due to a nearby TV set.</li> </ul>	<ul style="list-style-type: none"> <li>● Install the outdoor antenna away from the road.</li> <li>● Turn off the power to the appliance.</li> <li>● Install the system farther away from the TV set.</li> </ul>
A station which was preset cannot be received by pressing the corresponding numeric key.	<ul style="list-style-type: none"> <li>● The preset memory was cleared because the power cord had been unplugged for a long period of time.</li> <li>● The TUNER input is not selected.</li> </ul>	<ul style="list-style-type: none"> <li>● Preset the stations by auto memory again. </li> <li>● Select the TUNER input.</li> </ul>



Donot use contact cleaning agents because they could case a malfunction. Be specifically careful against using contact cleaning agents containing oil, since they may deform the plastic components.

**Remote control unit**

Symptom	Cause	Remedy
Remote control operation is not possible.	<ul style="list-style-type: none"> <li>Batteries are exhausted.</li> <li>The remote control unit is too far away from the main system, controlling angle is too large, or there is an obstacle in between.</li> <li>The audio cords and system control cords are not connected properly.</li> <li>The source component to be operated does not contain the tape(s) or disc.</li> </ul>	<ul style="list-style-type: none"> <li>Replace with new batteries. → 12 → 20</li> <li>Operate the remote control unit within the controllable range. → 11</li> <li>Connect properly referring to "System connection". → 5 → 7</li> <li>Place the tape(s) or disc in the source component to be played.</li> </ul>
The GRC screen is not displayed.	<ul style="list-style-type: none"> <li>Batteries are exhausted.</li> </ul>	<ul style="list-style-type: none"> <li>Replace with new batteries. → 12</li> </ul>
The GRC display is abnormal.	<ul style="list-style-type: none"> <li>Batteries are removed while something is displayed.</li> </ul>	<ul style="list-style-type: none"> <li>Remove and replace batteries after the information display has disappeared.</li> </ul>

**Set up code chart**

Although each setup code is designed to work with a number of different models, certain codes may not work with some models. (Also, certain codes may only operate some of the functions available on a given model.)

With some models, be sure to keep the ENTER key pressed for a while.

**Memory backup function**

Please note that the following items will be deleted from this unit's memory if the power cord is disconnected from the AC outlet for approximately three days.

- The input selection is cleared and the TUNER input is selected.
- The volume setting is cleared and the volume is set to -65 dB.
- The receiving band setting is cleared and the FM band is selected.
- The frequency setting is cleared and 87.5 MHz is selected.
- The preset station memory is cleared.
- The voice activation setting is cleared and the activation by non-specified person is set.
- The surround setting is cleared and reset to the initial condition.
- The clock and timer setup is cleared and the clock display shows AM 12:00 which is blinking.

# Specifications



Caution : Read this page carefully to ensure safe operation.

## Audio section

Total harmonic distortion (1 kHz, 1V)	0.01 %
Signal to noise ratio (IHF'66)	
CD	93 dB
Input sensitivity / impedance	
CD	200 mV / 47k $\Omega$
Tone controls	
BASS	$\pm 8$ dB (at 100 Hz)
TREBLE	$\pm 8$ dB (at 10 kHz)
Output level / impedance	
TAPE REC	200 mV / 1 k $\Omega$

## Video section

VIDEO inputs / outputs (composite)	1 V <sub>p-p</sub> /75 $\Omega$
---------------------------------------	---------------------------------

## FM Tuner section

Tuning frequency range	87.5 MHz~108 MHz
Usable sensitivity (DIN)	
MONO	1.2 $\mu$ V (at 75 $\Omega$ ) / 13.2 dBf (40 kHz dev., S/N 26 dB)
STEREO	35 $\mu$ V (at 75 $\Omega$ ) / 42 dBf (46 kHz dev., S/N 46 dB)
Signal to noise ratio (DIN weighted at 1 kHz, 40 kHz dev.)	
MONO	65 dB (65.2 dBf input)
STEREO	60 dB (65.2 dBf input)
Selectivity (DIN $\pm 300$ kHz)	64 dB
Stereo separation (DIN, 1 kHz)	36 dB
Frequency response	30 Hz~15 kHz, + 0.5 dB, - 3.0 dB

## MW Tuner section

Tuning frequency range	531 kHz ~ 1,602 kHz
Usable sensitivity (30% mod., S/N 20 dB)	20 $\mu$ V / (700 $\mu$ V / m)
Signal to noise ratio (at 30% mod. 1mV input)	48 dB

## LW Tuner section (U.K. only)

Tuning frequency range	153 kHz ~ 279 kHz
Usable sensitivity (30% mod., S/N 20 dB)	35 $\mu$ V
Signal to noise ratio (at 30% mod. 1mV input)	45 dB

## General

Power consumption	25 W
AC outlet UN SWITCHED	2: (Total 100 W max)
Dimensions	W:400 mm H:105 mm D:382 mm
Weight (net)	5.2 kg



1. KENWOOD follows a policy of continuous advancements in development. For this reason specifications may be changed without notice.
2. Full performance may not be exhibited in extremely cold locations (below 0 deg.C).

# KENWOOD

## For your records

Record the serial number, found on the back of the unit, in the spaces designated on the warranty card, and in the space provided below. Refer to the model and serial numbers whenever you call upon your dealer for information or service on this product.

Model \_\_\_\_\_ Serial Number \_\_\_\_\_



## Free Manuals Download Website

<http://myh66.com>

<http://usermanuals.us>

<http://www.somanuals.com>

<http://www.4manuals.cc>

<http://www.manual-lib.com>

<http://www.404manual.com>

<http://www.luxmanual.com>

<http://aubethermostatmanual.com>

Golf course search by state

<http://golfingnear.com>

Email search by domain

<http://emailbydomain.com>

Auto manuals search

<http://auto.somanuals.com>

TV manuals search

<http://tv.somanuals.com>