

KENWOOD

AV CONTROL CENTER

C-V751

INSTRUCTION MANUAL

KENWOOD CORPORATION

B60-4341-10 01 © (T, X) AP 9904

Before applying power

 **Caution : Read this page carefully to ensure safe operation.**

Units are designed for operation as follows.

- 2** Europe and U.K. AC 230 V only
Australia AC 240 V only

For the United Kingdom

Factory fitted moulded mains plug

1. The mains plug contains a fuse. For replacement, use only a 13-Amp ASTA-approved (BS1362) fuse.
2. The fuse cover must be refitted when replacing the fuse in the moulded plug.
3. Do not cut off the mains plug from this equipment. If the plug fitted is not suitable for the power points in your home or the cable is too short to reach a power point, then obtain an appropriate safety approved extension lead or adapter, or consult your dealer. If nonetheless the mains plug is cut off, remove the fuse and dispose of the plug immediately, to avoid a possible shock hazard by inadvertent connection to the mains supply.





IMPORTANT: The wires in the mains lead are coloured in accordance with the following code:

Blue : Neutral
Brown : Live

Do not connect those leads to the earth terminal of a three-pin plug.

Safety precautions

WARNING : TO PREVENT FIRE OR ELECTRIC SHOCK, DO NOT EXPOSE THIS APPLIANCE TO RAIN OR MOISTURE.

  	CAUTION: TO REDUCE THE RISK OF ELECTRIC SHOCK, DO NOT REMOVE COVER (OR BACK). NO USER-SERVICEABLE PARTS INSIDE. REFER SERVICING TO QUALIFIED SERVICE PERSONNEL.
	THE LIGHTNING FLASH WITH ARROWHEAD SYMBOL, WITHIN AN EQUILATERAL TRIANGLE, IS INTENDED TO ALERT THE USER TO THE PRESENCE OF UNINSULATED "DANGEROUS VOLTAGE" WITHIN THE PRODUCT'S ENCLOSURE THAT MAY BE OF SUFFICIENT MAGNITUDE TO CONSTITUTE A RISK OF ELECTRIC SHOCK TO PERSONS.
	THE EXCLAMATION POINT WITHIN AN EQUILATERAL TRIANGLE IS INTENDED TO ALERT THE USER TO THE PRESENCE OF IMPORTANT OPERATING AND MAINTENANCE (SERVICING) INSTRUCTIONS IN THE LITERATURE ACCOMPANYING THE APPLIANCE.

Unpacking



Unpack the unit carefully and make sure that all accessories are put aside so they will not be lost.

Examine the unit for any possibility of shipping damage. If your unit is damaged or fails to operate, notify your dealer immediately. If your unit was shipped to you directly, notify the shipping company without delay. Only the consignee (the person or company receiving the unit) can file a claim against the carrier for shipping damage.

We recommend that you retain the original carton and packing materials for use should you transport or ship the unit in the future.

Keep this manual handy for future reference.

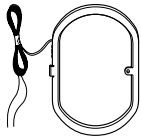
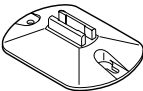

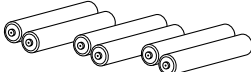

Accessories

FM indoor antenna (1)	AM loop antenna (1)	Loop antenna stand (1)	GRC-700 (1)	Batteries (R06/AA) (6)
				

Contents

Caution : Read the pages marked  carefully to ensure safe operation.

3

 Before applying power	2
 Safety precautions	2
Unpacking	2
Special features	4
How to use this manual	4
System connection	5
Connection of audio components (CD player, MD recorder, cassette deck, power amplifier)	5
Connection of video components (LD player, VCR, DVD)	6
Digital connections	7
About the system control connections	8
Connection of flat-cable connector	8
Connection of antenna	9
Using DVD 6ch INPUT	10
Controls and indicators	11
Setup of the Graphical Remote Control (GRC) unit	12
Controls and indicators	12
Operation of Graphical Remote Control	13
Setting up the GRC according to other components (Set Up)	15
Remote control of components from the GRC	18
Controlling the AV CONTROL CENTER	18
Controlling the components connected through system control cords	19
Convenient functions	22
One-touch operation features	22
Easy operation feature	22
Speaker settings	23
Setup for surround play (SET UP)	23
Playing music	27
Sound adjustment	29
Setup for surround play (SOUND)	29
Recording	31
Recording an analog input source	31
Recording a digital input source (CD, DVD)	33
Listening to radio broadcasts	38
Tuning radio stations	38
Functions of RDS	39
RDS DISPLAY key	39
Presetting RDS stations (AUTO MEMORY)	40
Storing radio stations manually in preset memory	41
Receiving all preset stations in order (P. CALL)	42
Receiving a preset station	42
Searching for a desired program type (PTY search)	43
Reserving the desired information (EON reservation)	45
Ambience effects	48
Surround modes	48
Surround play (LISTEN MODE)	50
To select the DSP mode (DSP)	52
Listen mode selection	53
Clock adjustment	54
Clock adjustment	54
Displaying the Time	54
Timer operation	55
Timer programming	55
Activating the timer	57
Sleep timer	58
Important Items	60
Maintenance	60
Reference	60
 In case of difficulty	61
 Specifications	63

4 Special features

True home theater sound

DTS

DTS (Digital Theater Systems) is a 5.1 channel digital audio format that provides five full-spectrum channels and one low-frequency (subwoofer) channel for unprecedented clarity, optimum channel separation and a (wide) dynamic range.

In the DTS mode, the 5.1 channel digital input from a DTS CD, LD or DVD disc (carrying the DTS marking) can be played in Digital Surround.

Important:

When a DTS disc is played on a CD, LD or DVD player, noise may be output from the analog output. It is recommended that you connect the digital output of the player to the digital input of this unit.

Dolby Digital (AC-3)

The DOLBY DIGITAL (AC-3) mode lets you enjoy full digital surround from software processed in the Dolby Digital (AC-3) format. Dolby Digital (AC-3) provides up to 5.1 channels of independent digital audio for better sound quality and more powerful presence than conventional Dolby Surround.

Dolby Pro Logic & Dolby 3 Stereo

This surround system reproduces theater-like surround sound from video software marked .

The PRO LOGIC mode uses the built-in adaptive matrix circuit to steer the Left, Center, Right and Surround channel audio signals.

The 3 STEREO mode will redirect the surround signal to the front left and right speakers when only the front and center speakers are used.

DSP surround modes

The DSP (Digital Signal Processor) used for this AV CONTROL CENTER incorporates a variety of high quality adjustable sound fields, like "ARENA", "THEATER", "JAZZ CLUB" to add the "presence" associated with an arena, theater, jazz club to the original signal. The DSP can process either PCM or analog sources.

Multi channel music (SRS Circle Surround)

SRS Circle surround enables you to listen to multi channel sound from the stereo source. We assume you have already enjoyed listening to Dolby digital sound / DTS multi channel sound with your multi speakers. Now, this time try listening to the stereo source (ex. Audio CD) using your multi speakers. You may discover a new type of "stereo" sound through SRS Circle Surround.

Graphical Remote Control unit "GRC"

The GRC unit incorporates a large-screen LCD which displays key icons and parameters. The LCD also shows information on the operating modes of the main unit. It incorporates sophisticated engineering and design to allow you to simply touch the screen to press buttons and operate controls. You can touch the screen with your finger or with the stylus stored at the top of the GRC.

To improve the operability, frequently used icons are located in the higher hierarchy in the LCD display and icons which are associated between each other are shown on the same screen.

The GRC unit is a multi-function remote control unit which can be programd to control AV components from other manufacturers than KENWOOD.

RDS (Radio Data System) tuner

The tuner of this AV CONTROL CENTER provides the RDS reception capability with wide functionality: The AUTO MEMORY automatically presets up to 40 RDS stations broadcasting different programs, the station name display shows you the name of the current broadcast station, and the PTY search lets you tune stations by program type.

ONE TOUCH OPERATION

Simply pressing the play key of the CD player or cassettedeck turns the system on and starts playback.

Low standby power consumption

The power consumption during standby is no more than 1.6 W.

How to use this manual

In this manual, the operating procedures are described on the left half of each page and the supplementary explanation, display information and other notes on each step are described on the right half.

(Example of instructions in this manual)

Operating procedure steps (Left half)

Supplementary explanation (Right half)

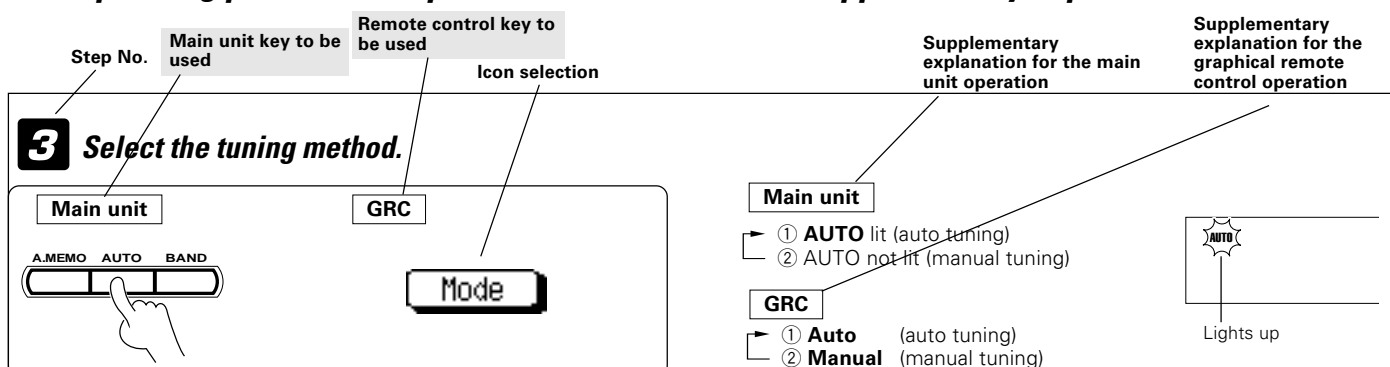

System connection

Connection of audio components (CD player, MD recorder, cassette deck, power amplifier)

Make connection as shown below.
When connecting the related system components, refer also to the instruction manuals of the related components.

⚠ Do not plug in the power lead until all connections are completed.

Malfunction of microcomputer
If operation is not possible or erroneous display appears even though all connections have been made properly, reset the microcomputer referring to "In case of difficulty". → 61

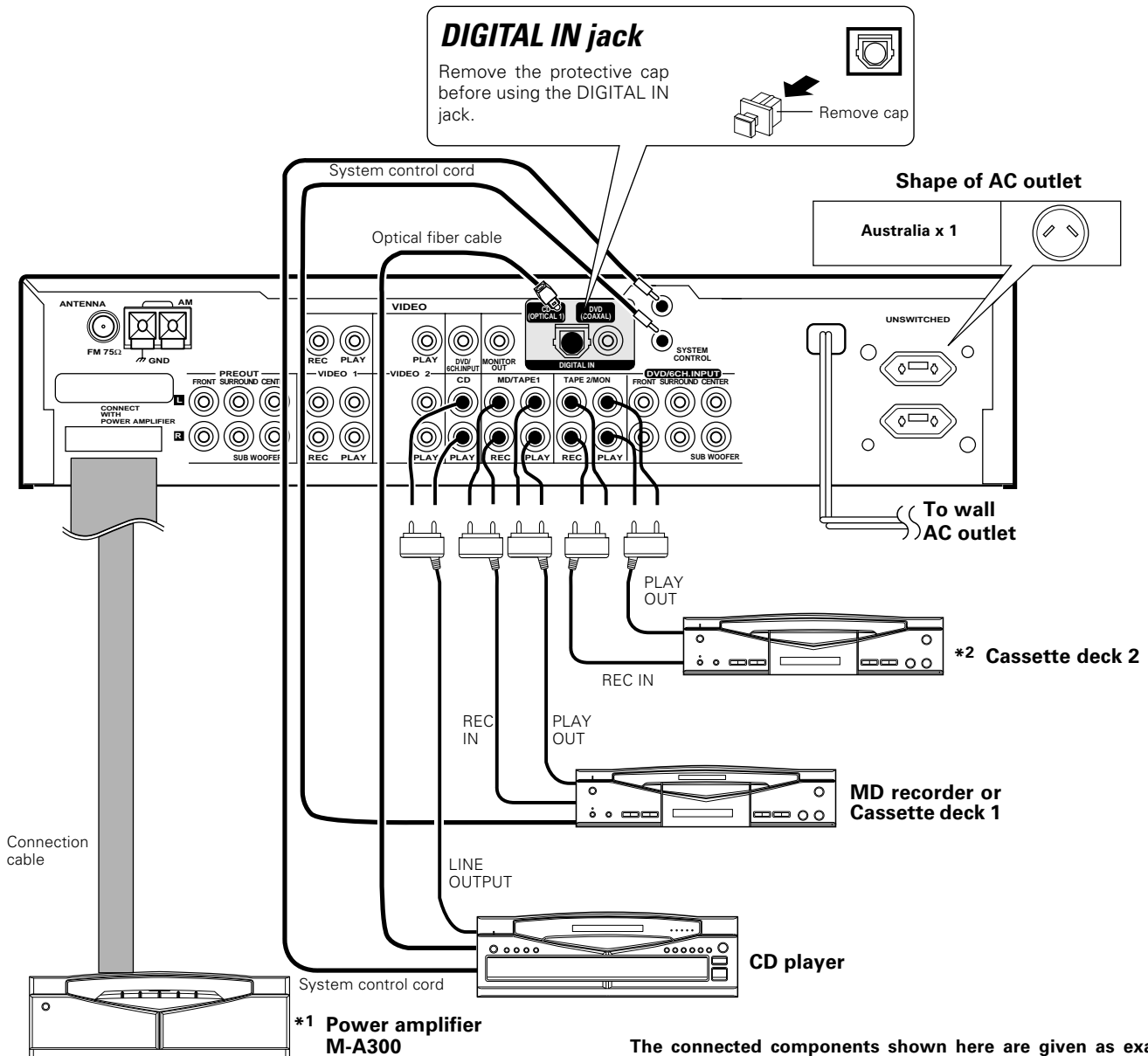

*1 For the connection and operation procedures of the power amplifier and speakers, refer to the instruction manual of the power amplifier (M-A300).

Also connect the system control cords when the KENWOOD Audio Component System "SERIES 21" is connected.

*2 Do not connect system control cord to the cassette deck connected to the TAPE 2/MONITOR jacks.

The connected components shown here are given as examples because the available models vary depending on marketing areas.

Caution regarding placement
Be sure to adhere followings. Or proper ventilation will be blocked causing damage or fire hazard.

- Do not place any objects impairing heat radiation onto the top of unit.
- Leave a space around the unit (from the largest outside dimension including projection) equal or greater than, shown below.
Top panel : 50 cm Side panel : 10 cm Back panel : 10 cm

Connection of video components (LD player, VCR, DVD)

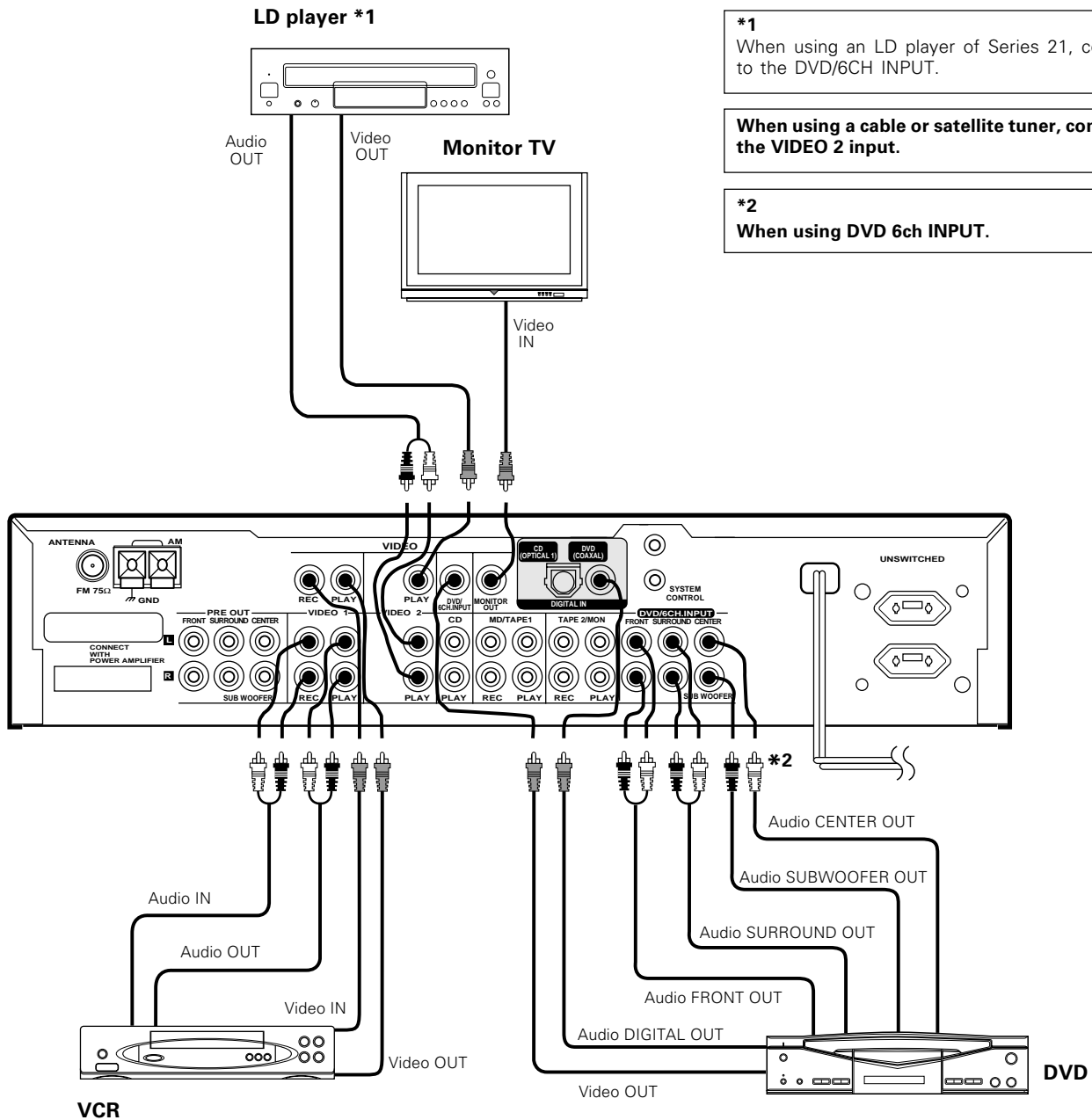

The connected components are given as examples because the available models vary depending on marketing areas.

DTS disclaimer clause

DTS Digital Surround™ is a discrete 5.1 channel digital audio format available on CD, LD, and DVD software which consequently cannot be decoded and played back inside most CD, LD, or DVD players. For this reason, when DTS-encoded software is played back through the analog outputs of the CD, LD, or DVD player, excessive noise will be exhibited. To avoid possible damage to the audio system, proper precautions should be taken by the consumer if the analog outputs are connected directly to an amplification system. To enjoy DTS Digital Surround™ playback, an external 5.1 channel DTS Digital Surround™ decoder system must be connected to the digital output (S/PDIF, AES/EBU, or TosLink) of the CD, LD or DVD player.

This unit is equipped with DTS Digital Surround™ decoder.

Digital connections

Make connections as shown below.

The digital in jacks can accept DTS, Dolby Digital (AC-3) or PCM signals. Connect components capable of outputting DTS, Dolby Digital (AC-3) or standard PCM (CD) format digital signals.

When connecting the related system components, be sure to also refer to the instruction manuals supplied with the components you are connecting.

Do not connect the power cord to a wall outlet until all connections are completed.

Connect components capable of outputting Dolby Digital (AC-3) or standard PCM format digital signals.

An LD player and DVD player cannot be connected simultaneously when an RF demodulator is used.

To connect an LD player with a DIGITAL RF OUT.

Connect the LD player to the KENWOOD RF digital demodulator (DEM-9991D). Then connect the demodulator to the AC-3 AUDIO INPUT DIGITAL IN.

Connect the video signal and analog audio signals to LD jacks (See "Connection of video components".) → 6

To connect an LD player with a DIGITAL OUT

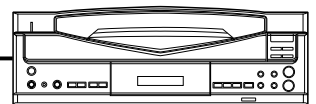

To connect a DVD player with a DIGITAL OUT

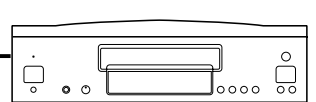

Connect the video signal and analog audio signals to the DVD jacks. (See "Connection of video components".)

→ 6

AC-3 RF Demodulator (DEM-9991D) (option)

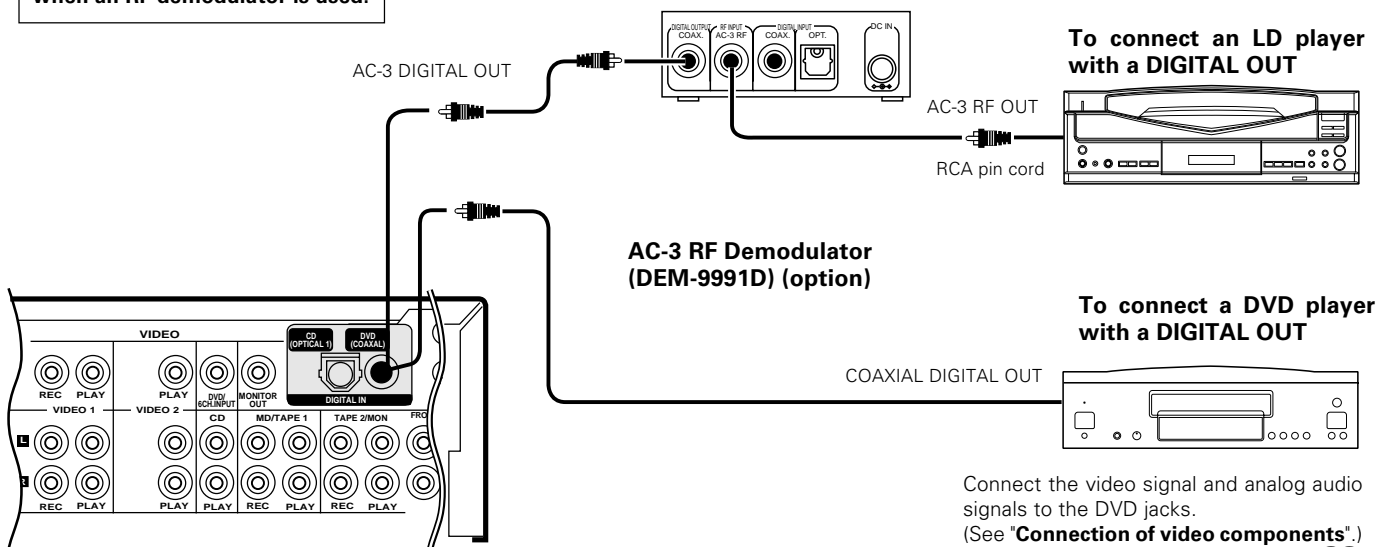

The connected components are given as examples because the available models vary depending on marketing areas.

8 About the system control connections

When this unit is connected to KENWOOD audio component system "SERIES 21", also connect them through the system control cords to allow system-control operations between components.

Connection example

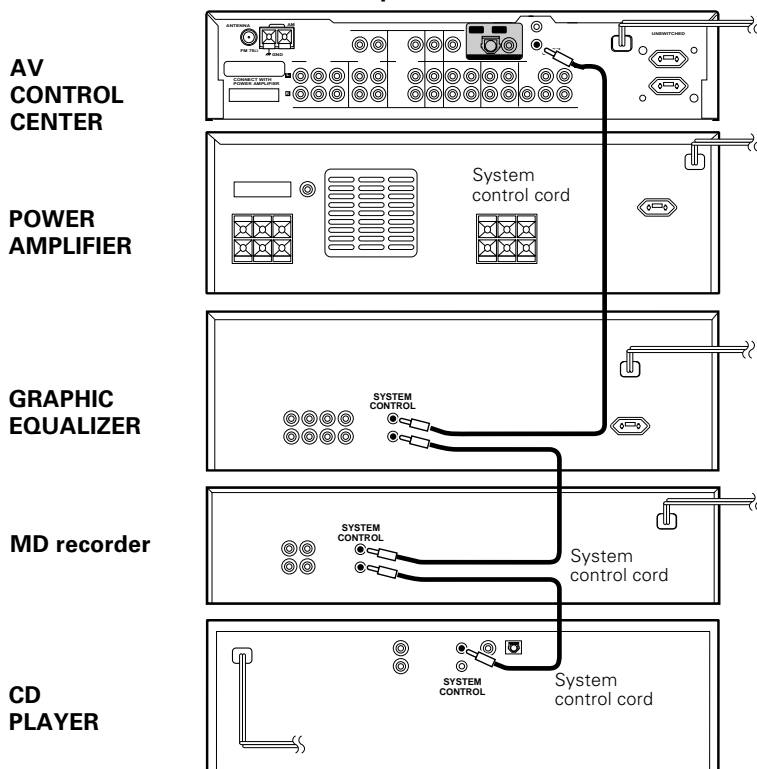

The SERIES 21 components which can be system-connected with this unit include the LD player, MD recorder and DVD player.



1. Do not connect the SERIES 21 components to other system components using system control cords.
2. Do not connect system control cords to any components other than those specified by KENWOOD. It may cause a malfunction and damage your equipment.
3. Be sure the system control plugs are inserted all the way in to the system control terminals.

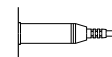

About the system control operations

(Available operations when SERIES 21 components are connected through system control cords)

Remote Control → 18

Lets you operate source components with the system remote supplied with this unit.

Automatic Operation → 22

When you start playback from a source component, the input selector on this unit switches to that component automatically. (Except TAPE 2)

Synchronized Recording → 31

Lets you synchronize recording with the start of playback when recording from CD etc.

Connection of flat-cable connector

Inserting the connector

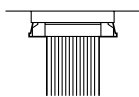

Push in the connector straight into the socket until it clicks to indicate the locking.

Removing the connector

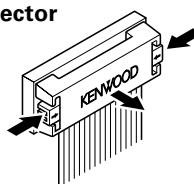

Push and hold the two ends of the connector, and pull it straight outward.



1. Connect all cords firmly. If connections are loose, there could be loss of sound or noise produced.
2. When plugging and unplugging connection cords, be sure to first remove the power cord from the AC outlet. Plugging / unplugging connection cords without removal of the power cord can cause malfunctions or damage to the unit.
3. Do not connect up a power source which is larger than that indicated on the socket at the rear of the unit.
4. If the system control cords or audio cords are not connected properly, the remote control or automatic operation between system components will not work properly.

Connection of antenna

Connection method to each antenna terminal

① Push lever.

② Insert cord.

③ Return lever.

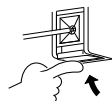
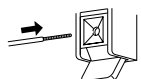

AM loop antenna connection

The supplied antenna is for indoor use. Place it as far as possible from the main system, TV set, speaker cords and power cord, and set it to a direction which provides the best reception.

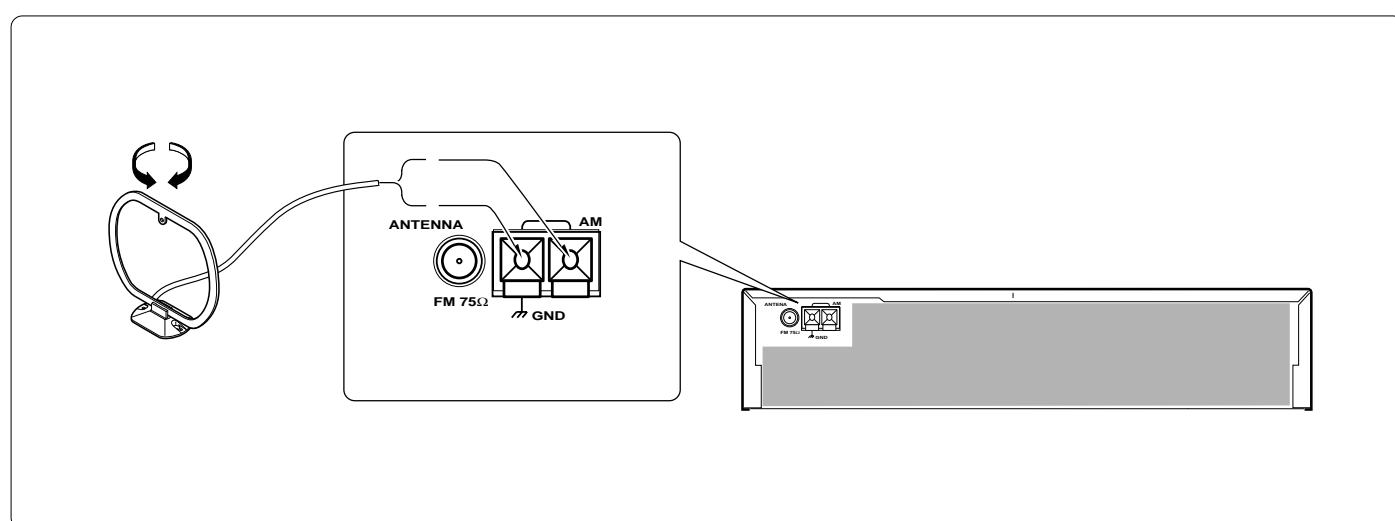

FM indoor antenna connection

The accessory antenna is for temporary indoor use only. For stable signal reception we recommend using an outdoor antenna. Remove the indoor antenna if you connect one outdoors.

FM outdoor antenna connection

Lead the 75 Ω coaxial cable connected to the FM outdoor antenna into the room and connect it to the FM 75 Ω terminal.

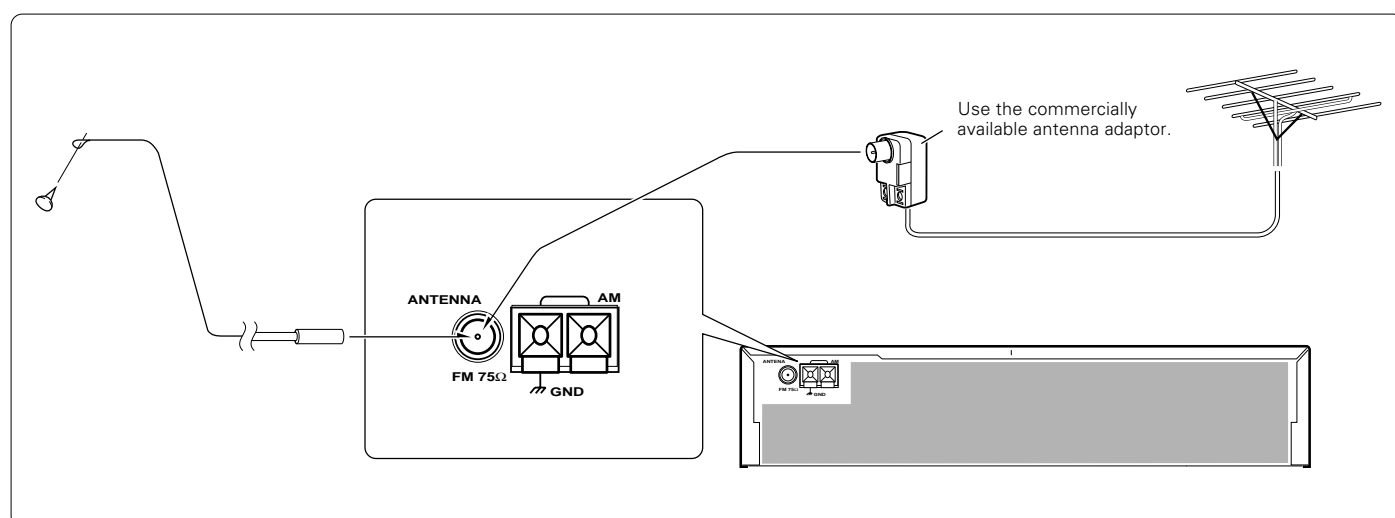

Using DVD 6ch INPUT

10

Opening/closing the door

① Press the ON/STANDBY key to ON.

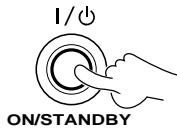

② Opening/closing the door

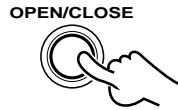

When opening or closing the door, be careful not to catch your finger in the door. Otherwise there is a risk of injury.

Changing the input selection display (AUTO key)

To make the system control operation, the input selection display should be switched according to the actually connected components. About the system control connections → 8

To change the DVD display into the DVD 6CH display or LD display.

Main unit

GRC

① Select "DVD" with the INPUT SELECTOR.

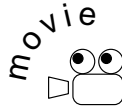
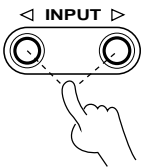

② Press the INPUT MODE key.

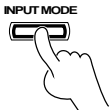

Select the "Input Analog" icon.

③ Press and hold the AUTO key for more than 2 seconds, until "DVD 6ch" is displayed. (Main unit only)

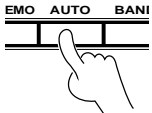

Analog input

Each press switches the indication.



Digital input

Each press switches the indication.

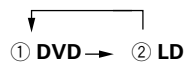

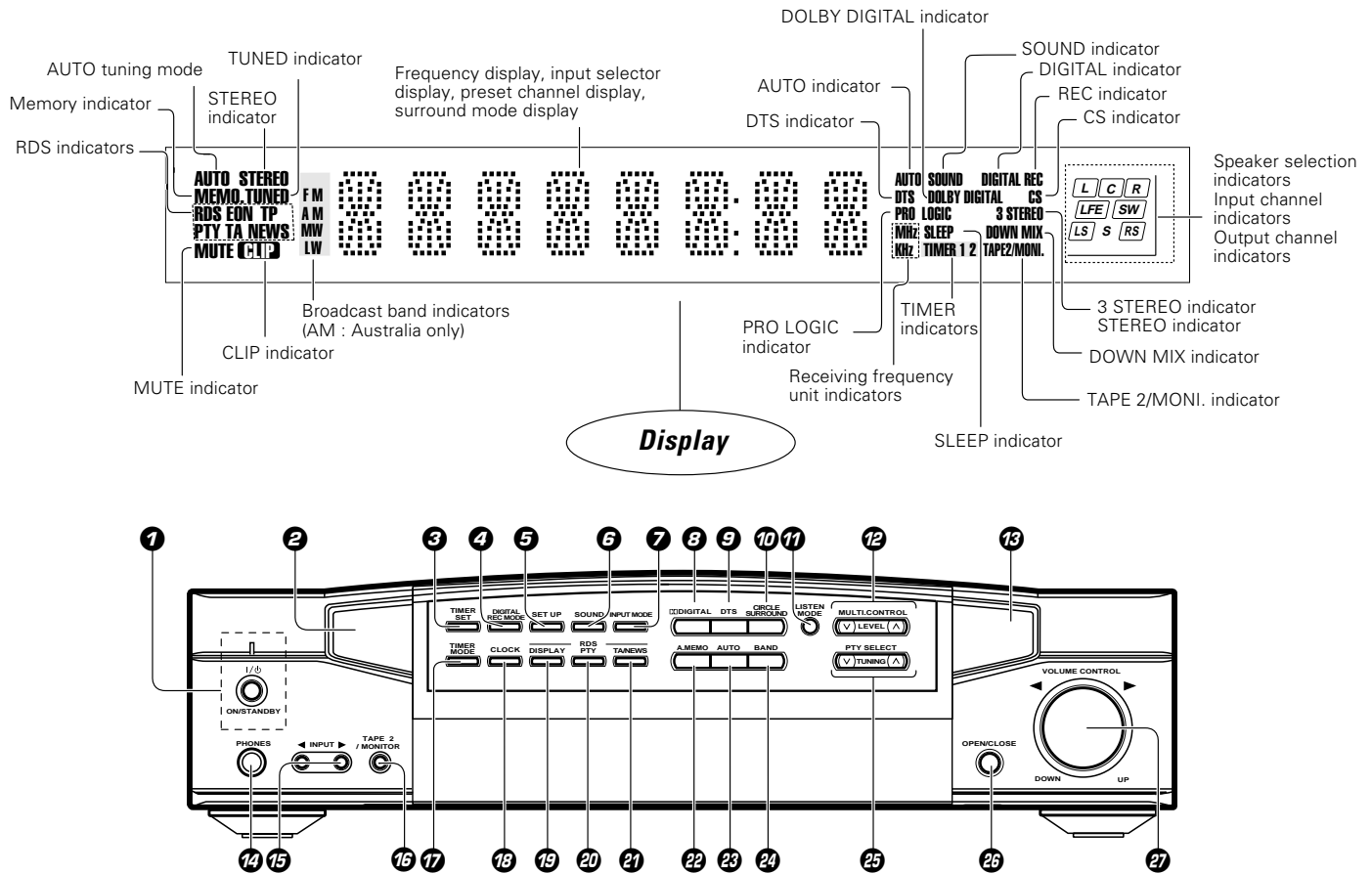

The keys which have the same names as the controls on the remote control unit provide the same functions as them.

- 1** I/⏻ (ON/STANDBY) key/indicator → 10
Press to switch between ON and STANDBY.
- 2** Remote sensor
- 3** TIMER SET key → 55
Press to set the timer function.
- 4** DIGITAL REC MODE key → 34
Use to select the DIGITAL REC mode.
- 5** SET UP key → 23
Use to select the surround sound settings.
- 6** SOUND key → 29
Use to adjust the sound quality and ambience effects.
- 7** INPUT MODE key → 18
Use to switch between the digital and analog inputs.
- 8** DIGITAL key → 50
Use to select the Dolby digital mode.
- 9** DTS key → 50
- 10** CIRCLE SURROUND key → 50
- 11** LISTEN MODE key → 50
Use to select the listening mode.
- 12** MULTI. CONTROL key → 54
Press to select various setting modes. These keys are also used in the clock adjustment and timer operations.
- 13** GRC transmitter
- 14** PHONES jack → 28
For use in headphones listening.
- 15** INPUT SELECTOR keys → 10
Press to select the input.
- 16** TAPE 2/MONITOR key → 28
For use in monitoring of recording, etc.
- 17** TIMER MODE key → 55
Press to switch the timer modes.
- 18** CLOCK key → 54
Press when setting the clock.
- 19** RDS DISPLAY key → 39
Press to switch the RDS display.
- 20** RDS PTY key → 43
For use during reception of RDS broadcasting.
- 21** MULTI. CONTROL key → 54
- 22** RDS TA/NEWS key → 46
For use during reception of RDS broadcasting.
- 23** A.MEMO key → 40
Press when using the auto memory function.
- 24** AUTO key → 10 → 38
Press to select the tuning mode. The auto tuning or manual tuning mode can be selected. Pressing and holding this key for more than 2 seconds changes the MD input display to TAPE 1 display or the DVD input display to DVD 6ch INPUT or LD display.
- 25** BAND key → 38
Press to switch the broadcasting band.
- 26** TUNING keys (∇, ▲) → 38
Press to select the radio station to be received.
- 27** OPEN/CLOSE key → 10
- 28** VOLUME CONTROL knob → 28

Standby mode

While the standby indicator of the unit is lit, a small amount of current is flowing into the unit's internal circuitry to back up the memory. This condition is referred to as the standby mode of the unit. While the unit is in the standby mode, it can be turned ON from the remote control unit.

Setup of the Graphical Remote Control (GRC) unit

12

Controls and indicators

The Graphical Remote Control (GRC) unit provided with the AV CONTROL CENTER can also control KENWOOD cassette decks, CD player, MD recorder and LD player which are connected to it through system control cords. For details of the controllable functions, refer to the instruction manuals of these components.

Model: GRC-700
Infrared system

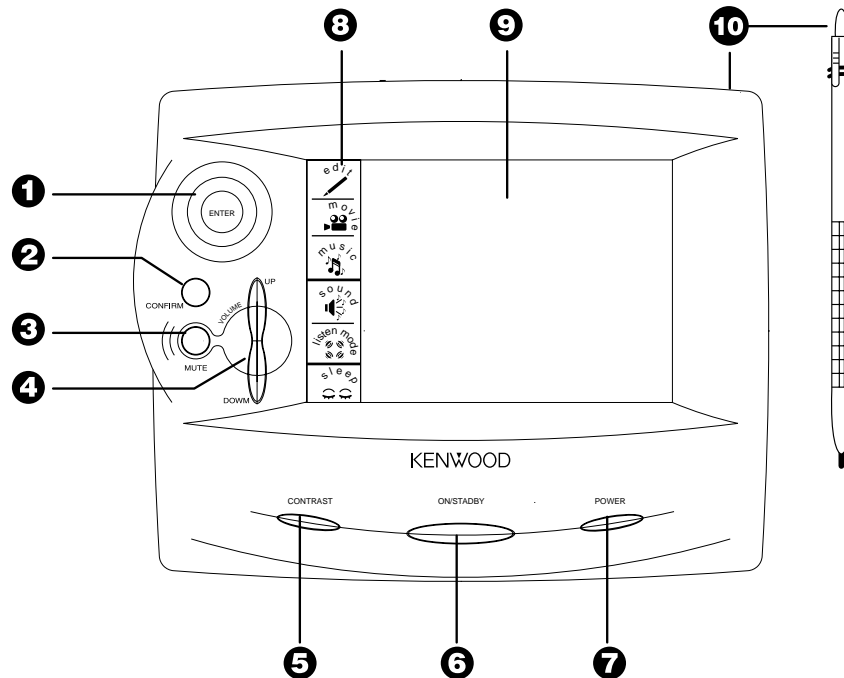

- 1 Joystick → 14
- 2 Confirm button → 14
- 3 Mute button → 28
- 4 Volume up/down button → 27
- 5 Contrast button → 14
- 6 On/Standby button → 27
- 7 Backlight button → 14

- 8 Quick Access menu → 18
 - edit** : Editing feature
 - movie** : Movie device controls such as DVD players or VCRs.
 - music** : Music device controls such as CD players or the radio tuner.
 - sound** : Sound controls, such as "midnight" mode.
 - listen mode** : Listen modes such as stereo, Dolby Digital.
 - sleep** : Sleep timer
- 9 Touch screen display → 13
- 10 Stylus (stored on top edge) → 13

Approximate operating range

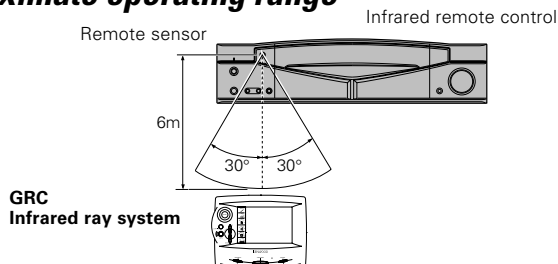

1. The supplied batteries are intended for use in operation check. Therefore, their lives may be shorter than ordinary batteries.
2. When the remote-controllable distance gets shorter than before, replace all 6 batteries with new ones.
3. Malfunction may occur if direct sunlight or the light of a high-frequency lighting fluorescent lamp enters the remote sensor. In such a case, change the system installation position to prevent the malfunction.
4. The GRC display may show erroneous information when the GRC unit is operated from outside the specified range.
5. The GRC unit may display incorrect information when the communication is not normal. In such a case, press the **CONFIRM** button.

Operation of Graphical Remote Control

Perform the following procedure after inserting batteries for the first time and every time after changing them.

Loading the batteries

Loading batteries

❶ Remove the cover.

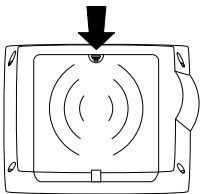

❷ Insert batteries.

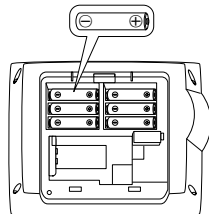

❸ Close the cover.

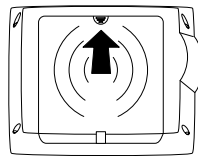

Caution in battery replacement

- Insert 6 AA-size batteries as indicated by the polarity marking.
- To maintain the memory of the settings you made before, complete the battery replacement operation within 30 seconds.

Remote control operation

❶ The touch screen responds to pressure from the included stylus or your finger.

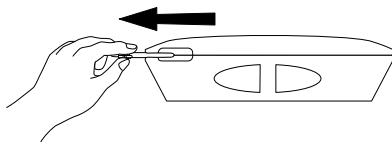

Calibrating the Touch screen

❶ To calibrate the touch screen, use the stylus to touch the center of each of the calibration points displayed.

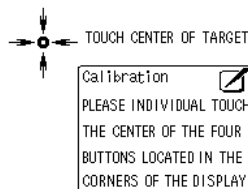

- When you touch each calibration point, you should hear a beep and see the next point, indicating that area of the screen is now calibrated. If you do not hear a beep, touch the calibration point until you do.
- The touch screen is sensitive to pressure, not to movement. Press firmly but gently on any touch screen element. The screen will not respond if you simply brush the stylus or your finger along the surface.
- If you are replacing batteries and complete the battery replacement within 3 minutes, you do not need to calibrate the screen; calibration is stored in memory.

To adjust the contrast

❶ Press the **CONTRAST** button until “Contrast” message appears on the screen.

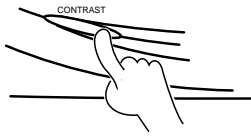

❷ While this message is displayed, move the joystick up or down to increase or decrease the contrast until you are satisfied.



❸ Press  the save the contrast setting and return to the control screen.

Backlight button

❶ To use GRC in the dark, press .

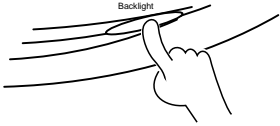

❷ To turn off the light and return to normal display, press  again.

- Backlight is automatically turned off when GRC goes to “sleep”—you will need to turn it on again when you reactivate GRC.



Keep the Back Light turned off during normal use to maximize the life of your batteries.

Resetting the GRC unit

❶ Open the cover.

❷ Use the stylus to press the blue button at the bottom of the battery case.

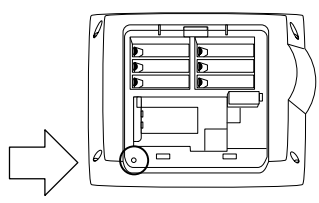

- If you are replacing batteries and complete the battery replacement within 3 minutes, you do not need to calibrate the screen; calibration is stored in memory.
- The setups made by the user are not cleared.

To reset to the factory setup

- While pressing and holding the **CONFIRM** and **VOLUME DOWN** button, use the stylus to press the blue button at the bottom of the battery case.

Icons

 Return to previous display

 Return to the main menu

 Quit the current display

 Go to the next hierarchy level

 Normal frame

Setting up the GRC according to other components (Set Up)

In the initial condition, the setup codes for CD, MD and DVD have already been pre-registered. The GRC can also be used to remote control other components which are not connected through system control cords.

In the operations of the GRC (Graphical Remote Control unit), proceed to each step within 10 seconds after the previous step. The display disappears in 10 seconds.



To resume GRC display, move the Joystick in any directions.

Registering setup codes for VIDEO 1

1 Enter the setup code.

- ① Select the "SET UP" icon.



- ② Select the "Preference" icon.



- ③ Press the "IR" icon.



- ④ Press the "Input" icon to open the list of available jack sets.



- ⑤ Press the "Device" icon to select the type of device you have connected to the jack set.



- ⑥ Press the "Brand" icon to select the device's brand.



Select the icon with or .

- ① CD
- ② MD/TAPE 1
- ③ VIDEO 1
- ④ VIDEO 2
- ⑤ DVD/DVD 6CH
- ⑥ TV 1
- ⑦ TV 2
- ⑧ TAPE 2/MONI.

Select the icon with or .

- ① CD
- ② TAPE
- ③ MD
- ④ VCR
- ⑤ CABLE
- ⑥ SATELLITE
- ⑦ TV
- ⑧ LD
- ⑨ DVD
- ⑩ Nothing

Continued to next page

- ➊ Press the "Code" icon. You can now choose from a list of all the codes available for the device. Select the first code on the list.



- ➋ Press the "Check" icon.



- ➌ Press the "Enter" icon.



Set up other components in the same way as above.

- When a code which is not shown in the setup code chart is entered, the entered code disappears automatically.
- Even when the system control code is connected, some models may not automatically display the "System" screen.
- With CD-Carrousel, select "Sys-carrousel".
- When CD, MD and TAPE are connected through system control cords, select "System".

Check the operation of the component.

- ➊ Display the operation screen of the component to be checked.
- ➋ Turn on the component from the GRC and confirm the actual component.
 - If there is more than one setup code, select the "Check" icon. This instructs GRC to send a "Power" test signal to the receiver. If your device turns on, the code you entered was correct. If it does not turn on, try the next code in the list. Continue until one of the codes works.



Although each setup code is designed to work with a number of different models, certain codes may not work with some models. (Also, certain codes may only operate some of the functions available on a given model.) With some models, be sure to keep the Check icon pressed for a while.

- If the device power cannot be turned ON/OFF, return to ➊ and select the net code in the list. Repeat ➊ and ➋ until the device power can be turned ON and OFF properly.

Programming remote control functions

Remote control functions of some components may not be available even after the setup codes have been registered. In this case, required functions can be programmed as if the GRC unit "learns" them.

To program STOP as a new control item

- ➊ Perform steps ➊ to ➌ in 1.
- ➋ Press the "Modify" icon.



- ➌ Select the function to be programmed.



- ➍ Aim the device's remote at GRC and press and hold the button on the device's remote that corresponds to the command you want GRC to learn.

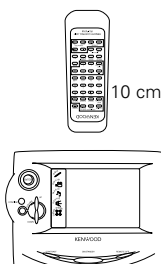

- This may take a few seconds; do not move GRC or the device's remote until GRC displays the the Function change menu again.
- Be sure to use the device's original remote. GRC will not learn commmands from other universal remotes.

Continued to next page

5 Repeat steps 2 through 4 until you have taught GRC all the commands you want it to know. If you need more lines, touch or to access more lines.

Programming an additional function which is not displayed in the screen

1 Repeat steps 1 and 2 in "To program STOP as a new control item". → 16
 2 Press the "Modify" icon.



3 Press the ▲ or ▼ icon to select one of "Empty 1 to 8".



4 Assign a name to the function.



5 Aim the device's remote at GRC and press and hold the button on the device's remote that corresponds to the command you want GRC to learn.

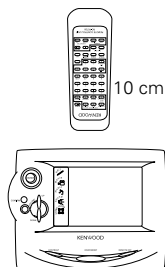

6 Repeat steps 2 through 5 until you have taught GRC all the commands you want it to know. If you need more lines, touch or to access more lines.

- The name can be composed using up to 8 characters.
- Touch **Char** to access to lowercase characters. Touch it again to access special characters (such as @, !, &, etc.). Touch it a third time to return to uppercase characters.
- Touch ◀ or ▶ to move back and forth between the characters.
- Touch **BS** (Backspace) to clear the last character you entered. Touch **ALL DEL** to delete all the characters in the line.

- This may take a few seconds; do not move GRC or the device's remote until GRC displays the Function change menu again.
- Be sure to use the device's original remote. GRC will not learn commands from other universal remotes.

- The additionally programmed function is registered in the **More** area.

Remote control of components from the GRC

18 Controlling the AV Control Center

The operations required to remote control the AV Control Center includes the INPUT SELECTOR selection, display mode selection, stereo selection and so on. The following procedures show how to remote control the basic operations of the GRC.

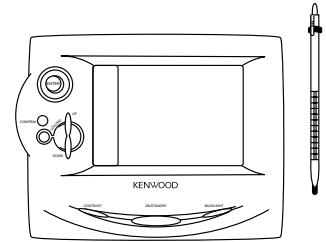

Operation examples

Switching the INPUT SELECTOR (Selecting the CD input)

- 1 Select the "music" icon in the Quick access menu.



- 2 Select the "CD" icon.

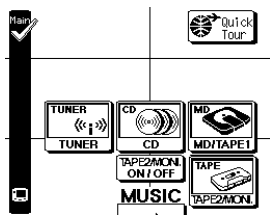

- 3 The input source is switched to "CD".

- Other input than CD can be selected in step 2.
- The icon of the registered component is displayed.

Selecting the listen mode (select STEREO)

- 1 Select the "listen mode" icon in the Quick access menu.



- 2 Select the "Stereo" icon.

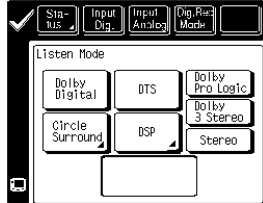

- It is also possible to select the Pro Logic, 3 STEREO icon in step 2.

Input mode settings

CD and DVD inputs each include jacks for digital audio input and analog audio input. You must select beforehand which type of input is to be used for each connected component. The initial factory setting is to use the digital audio signal for playback. To use the analog audio input for playback instead, you must set the input mode for the corresponding input to the analog mode. After completing connections and turning on the AV control center, follow the steps below.

Main unit

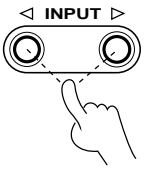

- 1 Use the INPUT SELECTOR key to select CD or DVD.

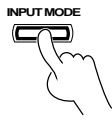

- 2 Press the INPUT MODE key.

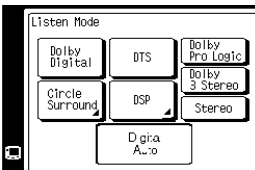

GRC

 or 

Digital input:
Select this setting to play digital signals from a DVD, CD, or LD player.

Analog input:
Select this setting to play analog signals from CD, DVD.

Auto sound:
In the auto sound mode (AUTO SOUND indicator lights), the AV control center selects the listening mode automatically during playback to match the type of input signal (Dolby Digital, PCM, DTS) and the speaker setting. The initial factory setting is auto sound on. To keep the receiver set to the currently selected listening mode, use the INPUT MODE key to select "DIGITAL MANUAL" (manual sound). However, even when this setting is selected, there may be cases in which the listening mode is selected automatically to match a Dolby Digital source signal depending on the combination of listening mode and source signal.

Each press switches the setting as follows:

In DTS play mode

- 1 DIGITAL AUTO (digital input, auto sound)
- 2 DIGITAL MANUAL (digital input, manual sound)

In other mode than DTS play mode

- 1 DIGITAL AUTO (digital input, auto sound)
- 2 DIGITAL MANUAL (digital input, manual sound)
- 3 ANALOG (analog input, manual sound)

- With DIGITAL MANUAL, the audio may sometimes be not output when the signal is switched.

Controlling the components connected through system control cords

When a CD player, MD recorder, cassette deck and/or DVD player are connected with the AV CONTROL CENTER through system control cords, their system control operations are possible from the GRC.

Preparations

- System control connection → 8
- Setup of source components → 15

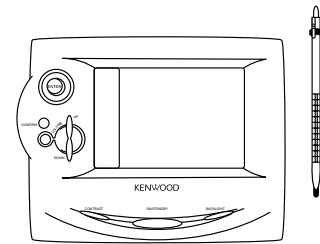

Select the "music" icon in the Quick access menu.

Operating the tuner

- 1 Select the "music" icon in the fixed segment screen.
(Select the icon)



- 2 Select the "TUNER" icon



Display the tuner operation menu.

- 3 Select the icon to be operated.

- Any of the keys which can control the tuner can be selected.

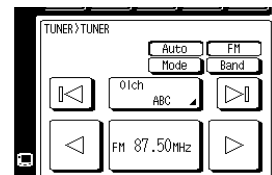

Operating the CD player

- 1 Select the "music" icon in the fixed segment screen.
(Select the icon)



- 2 Select the "CD" icon.



Display the CD operation menu.

- 3 Select the icon to be operated.

- The illustration shows the single CD operation menu.
- Any of the CD player operation keys can be selected.
- For the operation of the CD player, also read the instruction manual of the CD player.

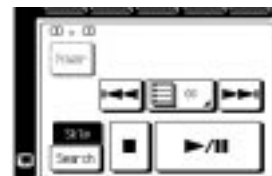

Operating the MD recorder

- 1 Select the "music" icon in the fixed segment screen.
(Select the icon)



- 2 Select the "MD/TAPE 1" icon.



Display the MD recorder operation menu.

- 3 Select the icon to be operated.

- Any of the MD recorder operation keys can be selected.
- For the operation of the MD recorder, also read the instruction manual of the MD recorder.

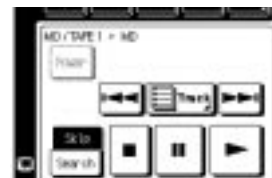

Operating the cassette deck

- 1 Select the "music" icon in the fixed segment screen.
(Select the icon)



- 2 Select the "MD/TAPE 1" icon.



Display the cassette deck operation menu.

- 3 Select the icon to be operated.

- Any of the cassette deck operation keys can be selected.
- For the operation of the cassette deck, also read the instruction manual of the cassette deck.



Select the "movie" icon in the Quick access menu.

Operating the DVD player

- 1 Select the "movie" icon in the fixed segment screen.
(Select the icon)



- 2 Select the "DVD/6CH." icon.



Display the DVD player operation menu.

- 3 Select the icon to be operated.

- Any of the DVD player operation keys can be selected.
- For the operation of the DVD player, also read the instruction manual of the DVD player.



Operating the LD player

- 1 Select the "movie" icon in the fixed segment screen.
(Select the icon)



- 2 Select the "LD" icon.



Display the LD player operation menu.

- 3 Select the icon to be operated.

- Any of the LD player operation keys can be selected.
- For the operation of the LD player, also read the instruction manual of the LD player.



Controlling the other components

Operating the Video cassette recorder

- 1 Select the "movie" icon in the fixed segment screen.

(Select the icon)



- 2 Select the "VIDEO 1" icon.



Display the Video cassette recorder operation menu.

- 3 Select the icon to be operated.

- Any of the Video operation keys can be selected.
- For the operation of the Video cassette recorder, also read the instruction manual of the Video cassette recorder.



Examples of component operation menus

The operation menus are variable depending on the connected components.

Operating the LD



Operating the TV



Operating the CABLE



Operating the SATELLITE



Operating the LD player (Non Kenwood)



One-touch operation features (Main unit only)

(CD player, cassette deck (Single deck only), DVD player)

When the system is in standby mode, the operations as described below are possible provided that the associated components are connected through system control cords.

Preparations

- 1 Ensure that system control cords are connected.
- 2 Load the source component with the software to be played.
- 3 Press the I/⏻ (ON/STANDBY) key of the AV CONTROL CENTER to put it to standby mode.

- The STANDBY indicator lights in the STANDBY mode.

Function available with the play key operation

- 1 Press the play key.
- 2 The system is switched from standby mode to ON mode.
- 3 The input selector is switched automatically.
- 4 Playback starts.

- CD player and cassette deck.

Easy operation feature

The operations as described below are possible provided that the associated components are connected through system control cords.

Operation available by switching the input selector

- 1 Select the desired input with the input selector.
- 2 The selected source component starts to play.

- Turn on the system before switching the input selector.
- Select the source component with the **INPUT SELECTOR**.

Setup for surround play (SET UP)

The feeling of presence in the surround effects can be improved by performing the following adjustment procedure according to the speaker system and listening room environment in use.

Once they are adjusted, re-adjustment is not necessary even after the surround mode is switched to other modes.

When the SERIES 21 speakers are used, the settings in steps 1 and 2 are not necessary.

Select the speaker setup mode

1 Select the speaker setup mode.

GRC

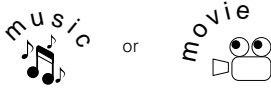

1 Select the "music" or "movie" icon in the fixed segment screen.



2 Select the "Main" icon.



3 Enter the setup mode.
(Select the icon)

4 Select "SP Selection" icon.



5 Select "Quick" or "Custom" icon.

 or 

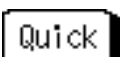
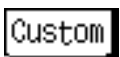
6 Select the item to be adjusted.
(Select the icon)

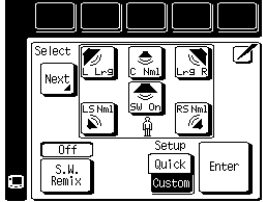

- ① **Quick Setup** : Use this method for a simplified setup where you identify whether a speaker is present and let the receiver automatically determine the appropriate speaker settings.
- ② **Custom Setup**: Use this method for a more customized setup where you determine more of the speaker settings, such as the bandwidth of the sound sent to each speaker.

Main unit

Each press of the **SETUP** key switches the adjustment items as shown below. Each press **MULTI CONTROL LEVEL** ∨ or ∧ key switches the indication.

- "SUBW" Sub-woofer ON/OFF setting.
 - "REMIX"*1 Sub-woofer remix ON/OFF setting.
 - "FRNT"*2 Front speaker setting.
 - "CNTR" Center speaker setting.
 - "SURR" Surround speaker setting.
 - TEST TONE Test tone output.
 - FRONT DISTANCE Front speaker distance.
 - CENTER DISTANCE Center speaker distance.
 - SURROUND DISTANCE Surround speaker distance.
- End of SET UP**

*1, *2 This setting is not available if "SW Off" is selected in the above.

● After adjusting the speaker size and ON/OFF setting, be sure to perform "Adjust the speaker level" → 25 using the test tone described in step 4.

2 Select a speaker system.

GRC

1 Set up the subwoofer. "SW"

(Select the icon)



2 Select On or Off.

Each press changes the setup.

3 Set up the subwoofer remix. "Remix"

(Select the icon)



4 Select On or Off.

Each press changes the setup.

5 Set up the front speaker size. "FRNT (L/R)"

(Select the icon)

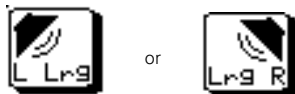

6 Select Nml or Lrg.

Each press changes the setup.

7 Set the center speaker size. "CNTR (C)"

(Select the icon)



8 Select Lrg, Nml or Off.

9 Set the surround speaker size. "SURR (LS/RS)"

(Select the icon)

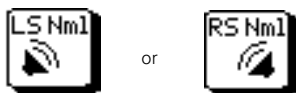

10 Select Lrg, Nml or Off.

11 Select the "Enter" icon.



12 Select the "Next" icon.



GRC

Quick setup

SW Yes : Subwoofer on

SW No : Subwoofer off

Custom setup

SW On : Subwoofer on

SW Off : Subwoofer off

- When the setting "**SW Off**" is selected, the front speakers automatically are set to "**Lrg**" and the procedure skips to step **7**.

SW Remix On : Subwoofer remix on

SW Remix Off : Subwoofer remix off

- This setting is not available if "**SW Off**" is selected in the above.
- Only the Custom setup can be set.
- If you selected "On" for the subwoofer, all of the bass below 80Hz is removed from other speakers in your system and is sent to the subwoofer in all listening modes.

L/R Nml (normal)

: Average size front speakers are connected to the AV control center.

L/R Lrg (large)

: Large front speakers are connected to the AV control center.

- When "**SW**" is set to ON and "**L/R**" is set to "**Nml**", "**C**" and "**LS/RS**" are set to automatically "**Nml**".

C Lrg : A large center speaker is connected to the AV control center.

C Nml : An average size center speaker is connected to the AV control center.

C Off : No center speaker is connected to the AV control center.

- When "**SW**" is set to ON and "**L/R**" is set to "**Nml**", "**C**" and "**LS/RS**" are set to automatically "**Nml**".

- When "**C**" is set to "**Nml**" or **Off**, "**LS/RS**" is automatically set to "**Nml**" or **Off**.

LS/RS Lrg : Large surround speakers are connected to the AV control center.

LS/RS Nml : Average size surround speakers are connected to the AV control center.

LS/RS Off : No surround speakers are connected to the AV control center.

3 Set the speaker distance.

GRC

- Measure the distance from the listening position to each of the speakers.
- Select a speaker distance.
(Select the icon)

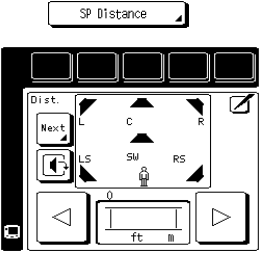

- Set "SP Distance".
(Select the icon)

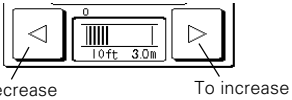

- Touch  to select the speaker.
- Repeat steps 3 and 4 for each speaker.
- Press the "Next" icon.
(Select the icon)



Jot down the distance from the listening position to each of the speakers

FRONT (L/R)	:	meter(s)
CENTER (C)	:	meter(s)
SURROUND (LS/RS)	:	meter(s)

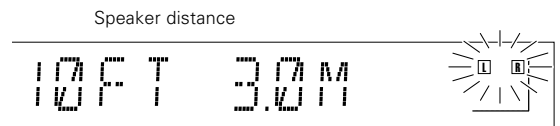

- The allowable setting range is 1 to 30 feet (0.3 to 9.0 m), adjustable in 1 foot (0.3 m) increments.
- The speakers you selected appear on the display. Confirm that all the speakers have been correctly selected.

4 Adjust the speaker level.

GRC

- Select a speaker level.
(Select the icon)







- Select "Test Tone" icon.
(Select the icon)



- The test tone which sounds like noise move across speakers in the following sequence about 2 seconds.

- ▶ **TEST Lch** (Front speaker, Left)
- TEST Cch** (Center speaker)
- TEST Rch** (Front speaker, Right)
- TEST RSch** (Surround speaker, Right)
- TEST LSch** (Surround speaker, Left)
- ▶ **TEST SWch** (Subwoofer)

- Even when "Test Tone" is "Off", it is possible to select the speaker with the  or  icon and adjust its level with the  or  icon.

Continued to next page

GRC

3 Adjust the levels of all the speakers than the front speakers (left, right).

While test tone is output from a speaker, adjust the volume level of the speaker.
(Select the icon)

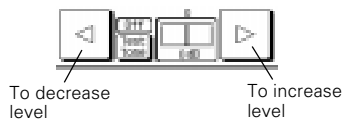

4 Repeat 3 until all the system's speakers (except the subwoofer) play at the same volume.

5 Press the "Test Tone" icon.
(Select the icon)



- The test tones is not output from the speaker which has been set to off. "Speaker settings" → 23



Display when test tone is output from a surround speaker

- Be sure to adjust from the listening position.
- Each press of the key increases or decrease the level by 1 dB.
- To set the subwoofer level, listen to familiar music or films that have strong bass content and adjust the subwoofer level until it sounds balanced with the rest of the speakers.
- When the volume level is increased during the "Test Tone" operation and it is finished while the volume level is high, the increased volume level will be maintained.

5 Adjust the input level. (analog sources only)

GRC

1 Select the "music" or "movie" icon in the fixed segment screen.

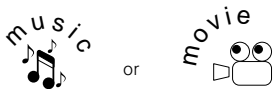

2 Select the "Main" icon.



3 Enter the SETUP mode.
(Select the icon)



4 Select the "Input" icon.
(Select the icon)

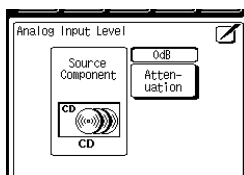

5 Select the "Attenuation" icon.
(Select the icon)



If the input level of an analog source signal is too high or the AV control center's CLIP indicator lights, adjust the input level.



If the CLIP indicator lights with analog input, set the input level to -3 or -6 dB to avoid sound distortion.

- This adjustment is not available with DVD 6ch INPUT.
- This adjustment is not available when the input mode is DIGITAL.
- The selected input level can be stored in memory on a per-selector basis.



Each press changes the level.

- ① 0 dB
- ② -3 dB
- ③ -6 dB

To quit the SETUP mode

GRC

Press the icon.

Playing music

The following procedure allows to play a MD, CD or cassette tape.

Preparations

- Connect components as described in "System connection". → 5
- Complete "Setup of the Graphical Remote Control (GRC) unit". → 12

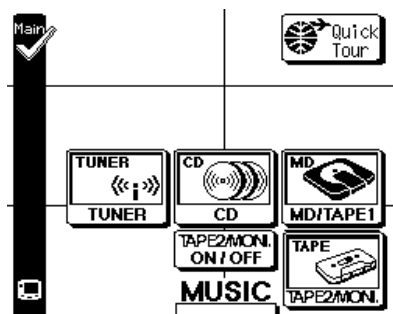

1 Press the ON/STANDBY key to ON.



- Load the CD player or cassette deck with the software to be played. → Read the instruction manuals of the associated components.

2 Select the input source.

Main unit INPUT (Select the icon)

GRC (Select the icon)

MUSIC

CD or MD/TAPE1

• Step 2 can be omitted if the easy operation feature is available. "Easy operation feature" → 22

With the main unit operation, the input sources are switched as shown below.

- ① TUNER (frequency display)
 - ② CD
 - ③ MD/TAPE 1
 - ④ DVD/DVD 6ch INPUT *1
 - ⑤ VIDEO 1
 - ⑥ VIDEO 2
- The selected source is displayed.
-

Pressing and holding the AUTO key for more than 2 seconds allows the source to be switched as shown below.

*1: To change the DVD display to DVD 6ch INPUT or LD display

To enable system-control operation, the displayed information should be set according to the actually connected components. → 10

3 Play the selected source.

Main unit (Select the icon)

GRC (Select the icon)

CD or MD

Operation on each source component

▶/|| or ▶

4 Adjust the volume.

Main unit VOLUME CONTROL

GRC

DOWN UP To decrease volume To increase volume

VOLUME UP DOWN To increase volume To decrease volume



- Rotating the VOLUME CONTROL at a higher speed increases the amount of volume change (AI VOLUME function).
- The sound of input source cannot be listened to while TAPE 2/MONITOR is ON. → 28

To listen through headphones

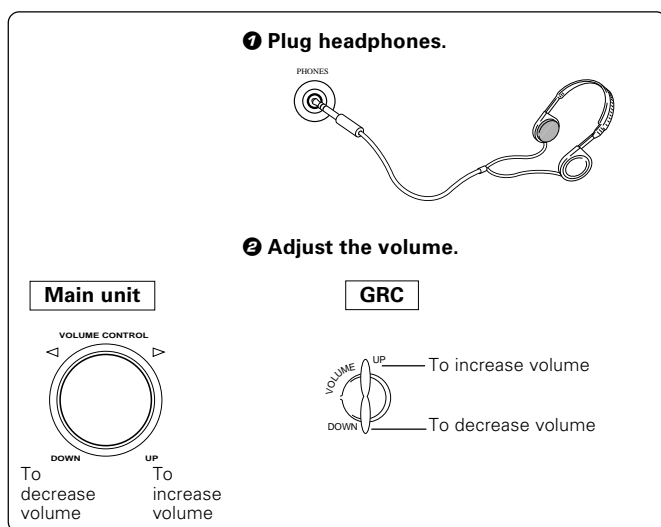

- The speaker sound is defeated at the moment headphones are inserted into the **PHONES** jack.
- If headphones are plugged in during surround play, its mode is automatically switched to the **STEREO** mode. If they are plugged in during **DVD 6ch INPUT** play, only the front L ch and R ch will be played. The previous status resumes at the moment headphones are unplugged.
- If headphones are plugged in during test tone output, the test tone output stops.

To mute sound temporarily

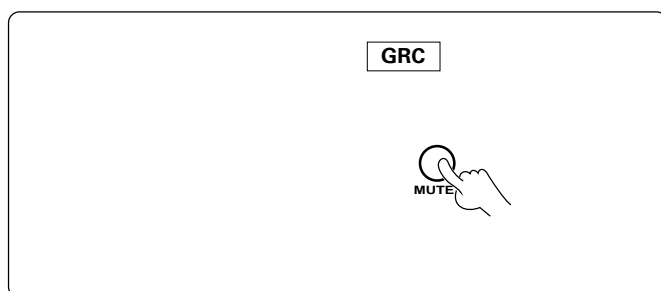

Main unit

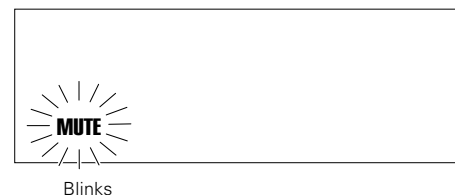

To cancel
Press the **MUTE** key again.

Notes for using the CD, DVD or DVD 6ch INPUT source

When **CD**, **DVD** or **DVD 6ch INPUT** is selected as the input source, the operation is subjected to the following restrictions.

Restrictions with CD and DVD:

1. When the input is a digital signal, the **TAPE2/MONITOR** function cannot be used.

Restrictions with DVD 6ch INPUT (except with the ANALOG input) :

1. The monitor function cannot be activated by pressing the **TAPE 2/MONITOR** key.
2. The Listen mode operations are not available.

- The speaker setting is not available with **DVD 6ch INPUT**.
- The sound adjustment is not available with **DVD 6ch INPUT**.
- When **DVD 6ch INPUT** is selected, all the speaker levels become 0 dB so the levels should be set on the source component.

Regarding TAPE 2/MONITOR

A cassette deck or graphic equalizer can be connected to this unit's **TAPE 2/MONITOR** terminals. If you connect a graphic equalizer, turn the **TAPE 2/MONITOR** key ON. If you connect a 3-head cassette deck, you can monitor the source sound, or the sound being recorded, while recording. Pressing the **TAPE 2/MONITOR** key lets you compare the recorded sound and the source sound. Refer to the operating manual for the component you connected for further details.

Adjustment for surround play (while listening to music) (SOUND)

1 Adjusting the tone (Stereo status only)

GRC

❶ Enter the **SOUND** adjustment mode.
(Select the icon)



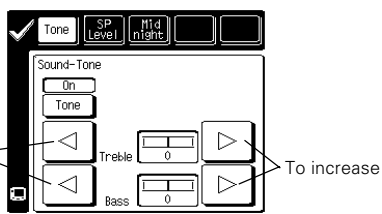

❷ Select the **"Tone"** icon.
(Select the icon)

Tone



❸ Touch **Tone** to turn the tone setting on or off.
This adjustment is possible only when the PCM or Analog input is used and the listen mode is set to STEREO.

❹ Touch the left  or right arrow  next to a tone setting (treble or bass) to adjust it. A readout  between the arrows shows the current setting.

Main unit

Each press of the **SOUND** key switches the indication.

- ❶ **BASS** : Tone, Bass
- ❷ **TREBLE** : Tone, Treble
- ❸ **C** : Center speaker
- ❹ **LS/RS** : Surround speaker, Left/Right
- ❺ **SW** : Sub woofer
- ❻ **MIDNIGHT**

- Adjustments ❶ and ❷ are not available in other modes than STEREO and "Tone" is set to "On".
- Adjustments ❸, ❹ and ❺ are available only when the corresponding speakers are set.
- The tone adjustment is not available with **DVD 6ch INPUT**. → 28
- With the GRC, the adjustment items shown in a single menu can be adjusted at once. (The adjustment steps ❶, ❷ are provided in a single menu so they can be adjusted successively without changing the menu screen.)
- ❻ is available only with the Digital input.



The display on the GRC disappears if no operation on the GRC has been pressed for about 7 seconds.

Bass tone level

BASS -2

- The level can be adjusted between -10 and +10 in step of 2.

Treble tone level

TREB +2

- The level can be adjusted between -10 and +10 in step of 2.

2 Adjust the volume levels for the speakers. (In other modes than stereo)

❶ Select the **"SP Level"** icon.
(Select the icon)

SP Level



- This adjustment is not available when **DVD 6ch INPUT** is selected.

Continued to next page

- 2 Adjust the center speaker level. "C"
(Select the icon)



- 3 Adjust to the desired level by pressing keys and

- 4 Adjust the surround speaker level. "LS/RS"
(Select the icon)

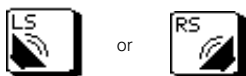

- 5 Adjust to the desired level by pressing keys and

- 6 Adjust the subwoofer level. "SW"
(Select the icon)



- 7 Adjust to the desired level by pressing keys and

Main unit

center speaker level

Cch +2

- The level can be adjusted between -10 and +10 in step of 1.

Surround speaker level

S + 1 / + 1

- The level can be adjusted between -10 and +10 in step of 1.

Sub woofer level

SW + 10

- The level can be adjusted between -10 and +10 in steps of 1.
- The volume levels adjusted here are just temporary; they return to the levels originally set in the setup operation when the power is turned off, the input selector is switched or the setup operation is started.

MIDNIGHT function

- 1 Select the "Midnight" icon.

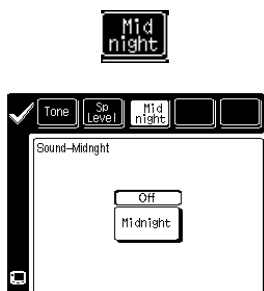

- 2 Select the MIDNIGHT mode.

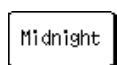

MIDNIGHT function

Any time you don't want to experience the loud and soft volume extremes of recorded sound (for example, late at night), use MIDNIGHT function to reduce volume extremes. This feature keeps loud, dramatic sound from being too loud (perhaps disturbing family members or neighbors) while ensuring that you can still hear whispered dialog or other soft sounds. Midnight function only works if you are listening to a Dolby Digital program that has been encoded with special compression data.

Each press changes the mode.

- 1 ... For quieter balancing.
- 2 ... For quietest balancing (the least difference between the loudest and quietest sound).
- 3 OFF

Recording

When recording sound with a recorder component of KENWOOD, synchro recording is possible by setting the INPUT SELECTOR to select MD or TAPE 1 according to the connected component.

Sound may not be reproduced when the input signal and LISTEN MODE are selected improperly.
How to select the digital input, analog input and LISTEN MODE. → 53

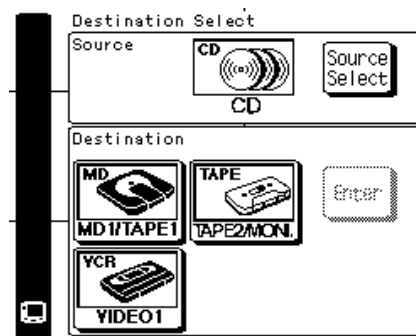

Recording an analog input source

1 To record a music source

Main unit

GRC

1 Select the "edit" icon in the fixed segment screen.
(Select the icon)

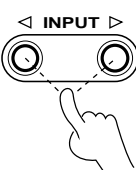
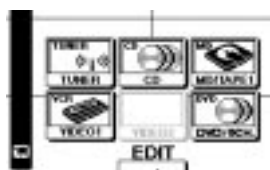

2 Select the source to be recorded.
Select an input source other than MD/TAPE 1.

3 Select the "Distination".

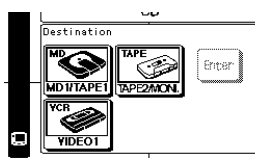

4 Press the "Src." icon.



- Main unit
- Each press switches the indication.
- ➔ ① TUNER (Frequency display)
 - ② CD
 - ③ MD/TAPE 1
 - ④ DVD/DVD 6ch INPUT
 - ⑤ VIDEO 1
 - ➔ ⑥ VIDEO 2

- GRC
- Select the icon of the source to be played.
- For the recording using a cassette deck or MD recorder, read the instruction manual of the cassette deck or MD recorder.

Continued to next page

2 Select the ANALOG input mode.

Main unit

GRC

1 Set the input mode to ANALOG.
(Select the icon)

INPUT MODE

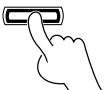



Main unit

Each press switches the indication.

- ① DIGITAL AUTO
- ② DIGITAL MANUAL
- ③ ANALOG

GRC

Select the icon of the source to be played.

- The switching is not available when the **DVD 6ch INPUT** is selected. → 28
- “③ ANALOG” cannot be selected when the input signal is the **DTS** signal.
- Each press of [Src.] or [Dst.] switches the display between “Source” and “Destination” alternately.
- The input mode cannot be changed during recording.
- Setting ① is not necessary unless when the **CD** or **DVD** source is selected.

3 Start recording.

Main unit

GRC

1 Play the source to be recorded.



2 Press the “Dst.” icon.





3 Press the record key to enter record-pause mode.

4 Press the “Src.” icon.



5 Pause the playing the source from beginning of the track being recorded.

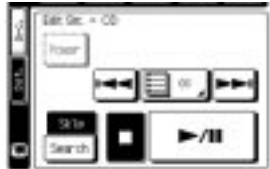

6 Play the source and start recording.

- The synchro recording function is not available when the playback source is the DVD player.

When recording sound with a recorder component of KENWOOD, synchro recording is possible by setting the INPUT SELECTOR to select MD or TAPE 1 according to the connected component.

Sound may not be reproduced when the input signal and LISTEN MODE are selected improperly.
How to select the digital input, analog input and LISTEN MODE. → 53

Recording a digital input source (CD, DVD)

1 To record a music source



Main unit

GRC



1 Select the "edit" icon in the fixed segment screen.
(Select the icon)



2 Select the source to be recorded.
Select an input source other than MD/TAPE 1.



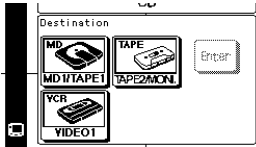

3 Select the "Destination".

Enter

4 Press the "Src." icon.



Main unit

Each press switches the indication.

- ① TUNER (Frequency display)
- ② CD
- ③ MD/TAPE 1
- ④ DVD/DVD 6ch
- ⑤ VIDEO 1
- ⑥ VIDEO 2

GRC

Select the icon of the source to be played.

- For the recording using a cassette deck or MD recorder, read the instruction manual of the MD recorder or cassette deck.

Continued to next page

2 Set the input mode to DIGITAL AUTO (MANUAL).

Main unit

GRC

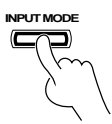

INPUT MODE

➊ Set the input mode to "DIGITAL AUTO (MANUAL)".
(Select the icon)



3 Select the DIGITAL REC mode.

AUTO REC MODE

Main unit



DIGITAL REC

➊ Set the REC mode to "AUTO REC MODE".

➋ Put the cassette deck (MD recorder) in record-pause mode.

MANUAL REC MODE

Main unit



DIGITAL REC

Method 1

➊ Play the source to be recorded.

➋ Set the input mode to "MANUAL REC MODE".

➌ Apply decoding that matches the input signal from the source selected and played in "➊" above.

Method 2

➊ Set the input mode to "MANUAL REC MODE".

➋ Play the source to be recorded.

➌ If audio is not output, switch the decoder by pressing the LISTEN MODE key.

Main unit

Each press switches the indication.

- ➊ **DIGITAL AUTO** Input signal is detected automatically.
- ➋ **DIGITAL MANUAL** Selected input signal is held.
- ➌ **ANALOG**

GRC

- ➊ **DIGITAL AUTO** Input signal is detected automatically.
- ➋ **DIGITAL MANUAL** Selected input signal is held.

- The switching is not available when the **DVD 6ch INPUT** is selected. → 28
- "➋ **ANALOG**" cannot be selected when the input signal is the **DTS** signal.
- Each press of **Src.** or **Dst.** switches the display between "Source" and "Destination" alternately.

Main unit

Each press switches the indication.

- ➊ **REC MODE OFF** Off
- ➋ **AUTO REC MODE**
- ➌ **MANUAL REC MODE**

Switch on the REC MODE to record a digital input source. Usually use the AUTO REC MODE to record audio input sources. When the digital mode changes during recording in the AUTO REC MODE, the audio may be interrupted momentarily. To record the audio from the beginning of the digital mode change, use the MANUAL REC MODE.

- The input is automatically down-mixed to 2 channels.
- Recording is not available when the **DVD 6ch INPUT** is selected. → 28
- The **EON** overriding does not occur during recording.
- For the recording using a cassette deck or MD recorder, read the instruction manual of the cassette deck or MD recorder.
- The **LISTEN MODE** key can be used to switch the decoder only when the **MANUAL REC MODE** is selected.
- Sound may not be reproduced when the input signal and LISTEN MODE are selected improperly.
How to select the digital input, analog input and LISTEN MODE. → 53

Continued to next page

GRC

- ❶ Select the "edit" icon in the fixed segment screen.

(Select the icon)



- ❷ Select the source to be recorded.

Select an input source other than MD/TAPE 1.

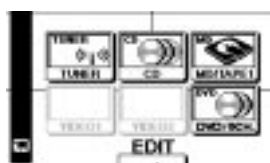

- ❸ Select the "Destination".

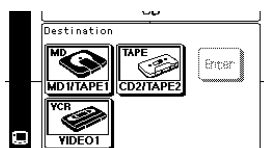

- ❹ Press the "Src." icon.



- ❺ Set the REC mode to "Dig. Rec Mode.".

(Select the icon)



- ❻ Play the source to be recorded.



- ❼ Press the "Dst." icon.



- ❽ Press the record key to enter record-pause mode.

GRC

Select the icon of the source to be played.

- For the recording using a cassette deck or MD recorder, read the instruction manual of the MD recorder or cassette deck.
- The input is automatically down-mixed to 2 channels.
- Recording is not available when the **DVD 6ch INPUT** is selected. → 28

GRC

- ❶ **REC MODE OFF** Off
- ❷ **AUTO REC MODE**
- ❸ **MANUAL REC MODE**

Switch on the REC MODE to record a digital input source. Usually use the AUTO REC MODE to record audio input sources. When the digital mode changes during recording in the AUTO REC MODE, the audio may be interrupted momentarily. To record the audio from the beginning of the digital mode change, use the MANUAL REC MODE.

- The switching is not available when the **DVD 6ch INPUT** is selected. → 28
- ❸ cannot be selected when the input signal is the **DTS** signal.
- Each press of [Src.] or [Dst.] switches the display between "Source" and "Destination" alternately.
- If audio is not output, switch the decoder by pressing the **LISTEN MODE** key.

Continued to next page

4 Start recording.

Main unit

GRC

- 1 Press the "Src." icon.



- 2 Pause the playing the source from beginning of the track being recorded.



- 3 Play the source and start recording.



Listening to radio broadcasts

Radio stations can be classified into RDS (Radio Data System) stations and other stations. For listening to RDS stations or storing RDS stations in preset memory, see section entitled "Functions of RDS". → 39

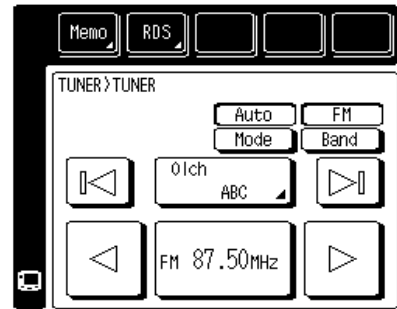

Tuning radio stations

1 Select the TUNER input.

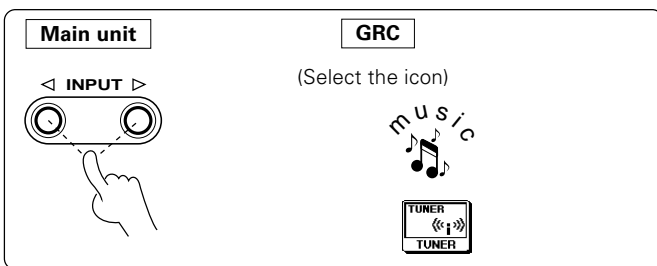

Main unit

Each press switches the indication.

- ① TUNER (Frequency display)
- ② CD
- ③ MD/TAPE 1
- ④ DVD/DVD 6ch
- ⑤ VIDEO 1
- ⑥ VIDEO 2

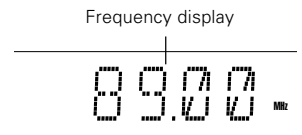

- The previously tuned frequency is displayed.

2 Select the broadcast band.

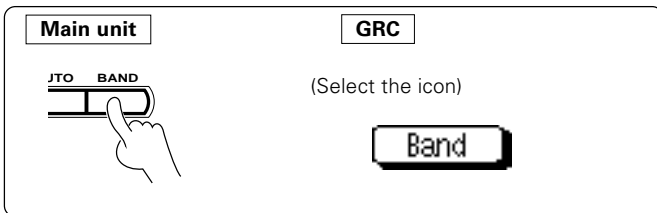

Main unit

Each press switches the indication.

- ① FM
- ② MW
- ③ LW
- ① FM (Australia only)
- ② AM (Australia only)

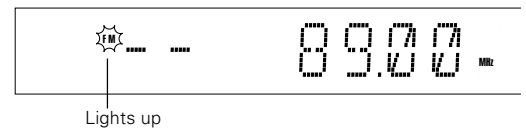

3 Select the tuning method.

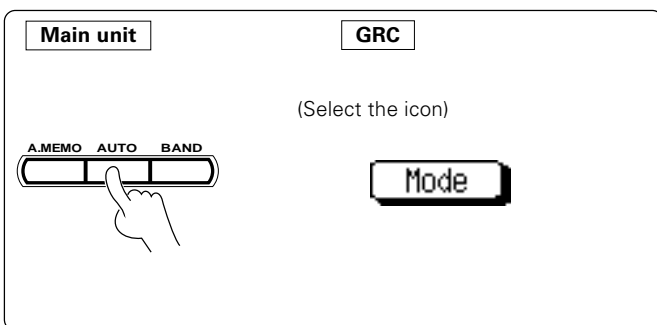

Main unit

- ① AUTO lit (auto tuning)
- ② AUTO not lit (manual tuning)

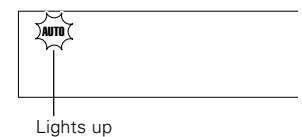

GRC

- ① Auto (auto tuning)
- ② Manual (manual tuning)

- Normally, set to "AUTO" (auto tuning). If the radio waves are weak and there is a lot of interference, switch to manual tuning. (With manual tuning, stereo broadcasts will be received in monaural.)

4 Select a station.

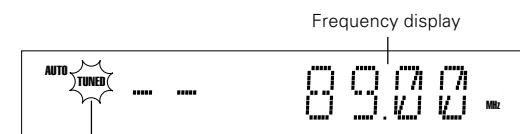
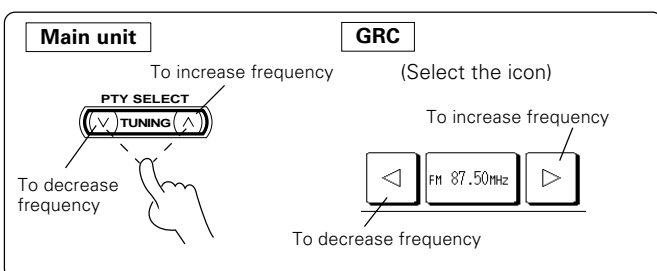

- Auto tuning : The next station found is tuned automatically.
- Manual tuning : Press and hold the key until the desired station is received.

Functions of RDS (Radio Data System)

RDS is a system which transmits useful information (digital data) for FM broadcasts together with the broadcast signal. Tuners and receivers designed for RDS reception can extract the information from the broadcast signal for use with various functions such as automatic display of the station name.

Functions made possible with RDS

PTY (Program Type Identification) Search :

The tuner automatically searches for a station which is currently broadcasting a specified program type (genre). → 43

EON (Enhanced Other Network) reservation

By selecting one of the two kinds of program previously, the tuner switches automatically to a station broadcasting that kind of program whenever it starts broadcasting. When the broadcasting completes, the tuner returns automatically to the originally-received station. → 45

PS (Program Service Name) display : See figure ① below.

When an RDS broadcast is received, the station name is automatically displayed.

RT (Radio Text) display :See figure ② below.

Some of the RDS stations also transmit text data. When the RT display is selected with the **RT** key, the broadcast text is scrolled on the display.

AUTO MEMORY

This function automatically selects the stations providing RDS and FM broadcasting and stores them in the preset memory (up to 40 stations can be preset). → 40

The **RDS** indicator lights up when an RDS broadcast (signal) is received.

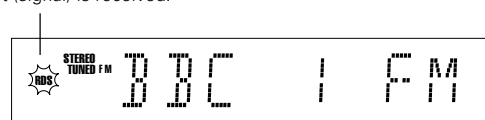

- Some functions may not be provided or be given different names depending on countries or areas.



Before using a function utilizing the RDS, be sure to perform the AUTO MEMORY operation by referring to the description in "Presetting RDS stations (AUTO MEMORY)". → 40

RDS DISPLAY key

Main unit

GRC
(Select the icon)

Pressing the **RDS DISPLAY** key changes the display contents.

Disp.

Display mode priority ranking

When an FM broadcast is received :

- ① **PS (Program Service Name) display**
- ② **RT (Radio Text) display**
- ③ **Frequency display**

① PS (Program Service Name) display :

When an RDS broadcast is received, the station name is automatically displayed.

If no PS data was sent, "**NO PS**" is displayed.

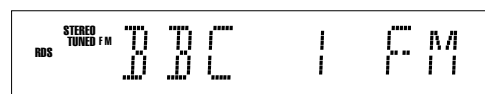

② RT (Radio Text) display:

Text accompanying RDS broadcast is scrolled on the display during reception. "**NO RT**" is displayed if the received RDS station is not accompanied with RT data.

Text is scrolled from the right to the left.

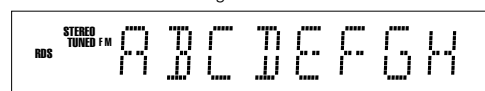

③ Frequency display :

The frequency of the current station is displayed.

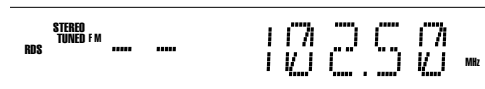

Use the operating procedure on this page to store RDS stations automatically in preset memory. Up to 40 RDS stations can be preset and received with a simple key operation.

This unit is compatible with the RDS so it can use convenient RDS functions including automatic tuning and EON reservation.

RDS stations should be stored in the preset memory following the procedure in "Presetting RDS stations" before listening to RDS stations.

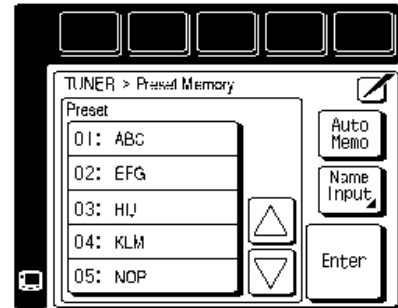

Presetting RDS stations (AUTO MEMORY)

The following procedure allows to select stations broadcasting RDS broadcast and store them in the preset memory (up to 40 stations can be preset).

1 Select the TUNER input.

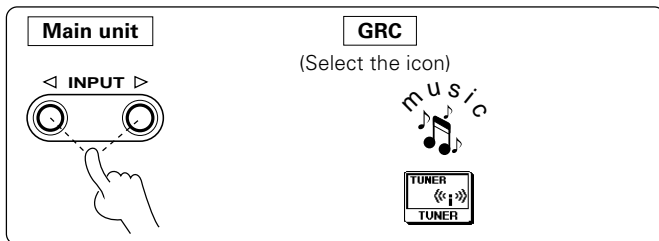

Main unit

Each press switches the indication.

- ① TUNER (Frequency display)
- ② CD
- ③ MD/TAPE 1
- ④ DVD/DVD 6ch INPUT
- ⑤ VIDEO 1
- ⑥ VIDEO 2

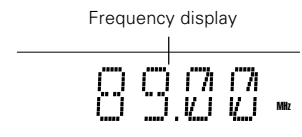

- The previously tuned frequency is displayed.

2 Select the broadcast band "FM".

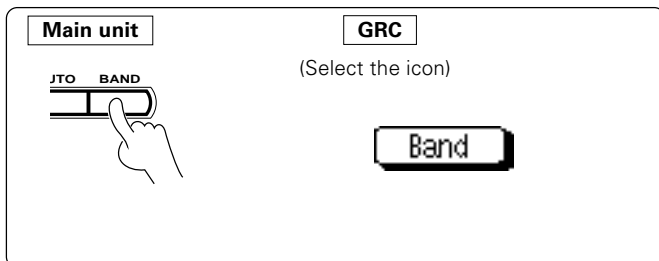

Main unit

Each press switches the indication.

- ① FM
- ② MW
- ③ LW

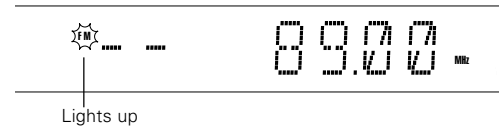

3 Preset radio stations by AUTO MEMORY.

Main unit

Press the A.MEMO key.

GRC

(Select the icon)

① Perform step 1~2 of "Tuning radio stations" → 38

② Press the "Memo" key during receiving a station.

③ Press the "Auto Memo" key.

(Select the icon)

In a few minutes, the stations with which RDS broadcast is received are stored in order beginning from preset channels "01" (up to 40 stations can be preset).

If the number of stations with RDS broadcasting is less than 40, non-RDS FM stations will be preset after the RDS stations.

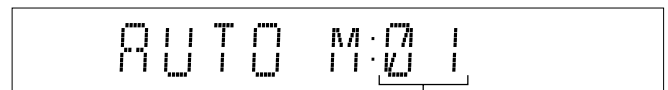

← Scroll display "AUTO MEMORY" Number of preset stations



- If stations have already been stored in preset channels, the same number of these preset channels as the number of stations are replaced with the data of the newly preset stations.

The AUTO MEMORY function gives precedence to RDS stations and assigns them from preset number 1. Therefore, when it is required to preset RDS stations as well as non-RDS stations, execute the AUTO MEMORY operation first then proceed to the manual memory operation of non-RDS stations.

Preparation

- Select the **TUNER** input. → 19
- Display the Tuner operation menu. → 19

Order of radio station presetting



Other stations than the RDS stations can be stored in the preset memory by presetting them after the RDS stations preset by AUTO MEMORY as shown below or overwriting the RDS stations preset in some preset numbers.

Preset number	
1 2	39 40
① AUTO MEMORY RDS stations (~ FM stations)	② Manual memory FM, MW or LW stations FM, AM stations (Australia only)

Storing radio stations manually in preset memory

GRC

① Perform step 1~2 of "Tuning radio stations" → 38

② Press the "Memo" icon during receiving a station.



③ Select the preset channel for use in pre-setting the station.

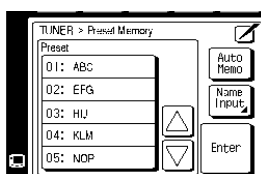

④ Press the "Enter" icon.
(Select the icon)



⑤ Assigning a name to preset memory.
(Select the icon)



⑥ Select the preset channel to be named by pressing or .

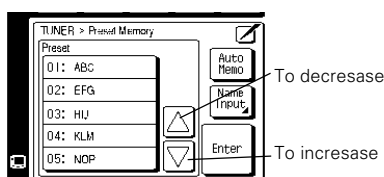

⑦ Press the "Name Input" icon to select the name input mode.
(Select the icon)



⑧ Compose a name.

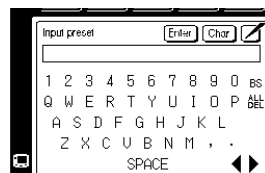

• Apart from the auto memory function, radio stations can also be stored manually in the preset memory.

- It is also possible to assign a station name to the manually preset station.
- Repeat steps ①, ②, ③, ④ for each of the stations to be stored in memory.
- If a station is stored in a preset number which has already stored a station memory under it, the previous memory is replaced by the new memory content.
- If RDS stations are stored manually in the preset memory, the PS may not be included in the memory depending on receiving conditions.

- The name can be composed using up to 8 characters.
- Touch to access to lowercase characters. Touch it again to access special characters (such as @, !, &, etc.). Touch it a third time to return to uppercase characters.
- Touch or to move back and forth between the characters.
- Touch **BS** (Backspace) to clear the last character you entered. Touch **ALL DEL** to delete all the characters in the line.

Continued to next page

GRC

- 9 Press the "Enter" icon to enter in memory.
(Select the icon)

Enter

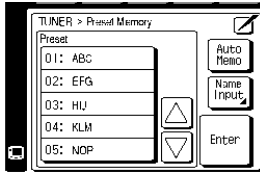

- 10 Press the "Enter" icon.

Enter

- To preset other stations, repeat 6 to 9 for each of them.

Receiving all preset stations in order (P. CALL)

GRC

- 1 Select the preset number of the desired station by pressing or .

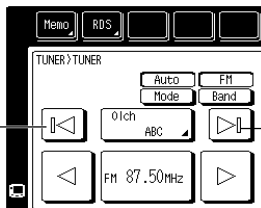

The preset number decreases.

The preset number increases.

- Every time the key is pressed, the next station in the order of the preset number is received.

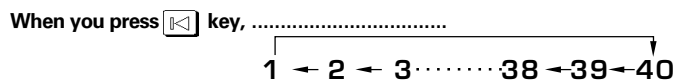
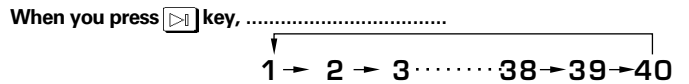

If the key is held pressed Preset stations will be received successively for about half a second each.

Receiving a preset station

GRC

- 1 Press the preset call icon.

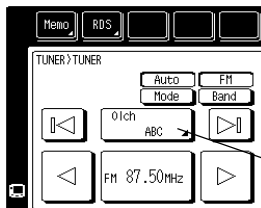

Preset call icon

- 2 Select the preset number of the desired station by pressing or .



To decrease

To increase

- 3 Press the "Enter" icon.
(Select the icon)

Enter

Preset number stored in memory

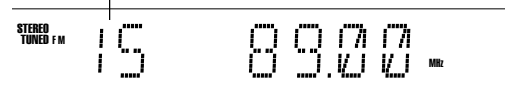

- Enter the preset number (max. 40) of the desired radio station.

By specifying the type of program (genre) you want to listen to, the tuner automatically searches for a station which is currently broadcasting a program of the specified type.

With certain receiving conditions, it may take more than 1 minute until the search completes.

- Preparation**
- Preset RDS stations with the **AUTO MEMORY** function. → 40
 - Select the **TUNER** input. → 40
 - Set the receiving band to **FM**. → 40

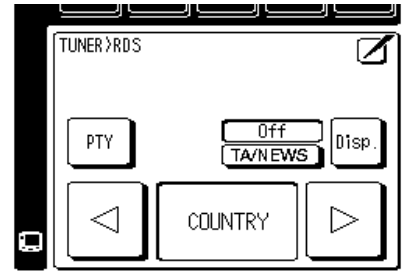

Note This step can be omitted if you have already executed the AUTO MEMORY procedure.

Searching for a desired program type (PTY search)

1 Select the PTY search mode.

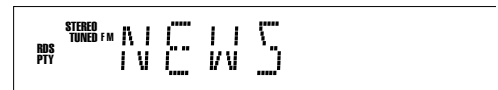
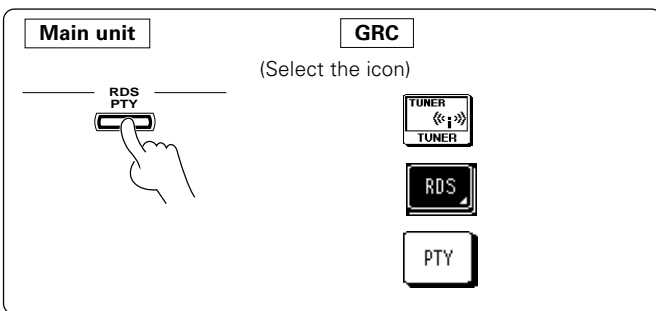

When an RDS broadcast is received, the program type is shown on the display. If no PTY data is available, or if the station is not an RDS station, "NONE" is displayed.

2 Select the desired program type.

Use program type table on the right for your convenience.

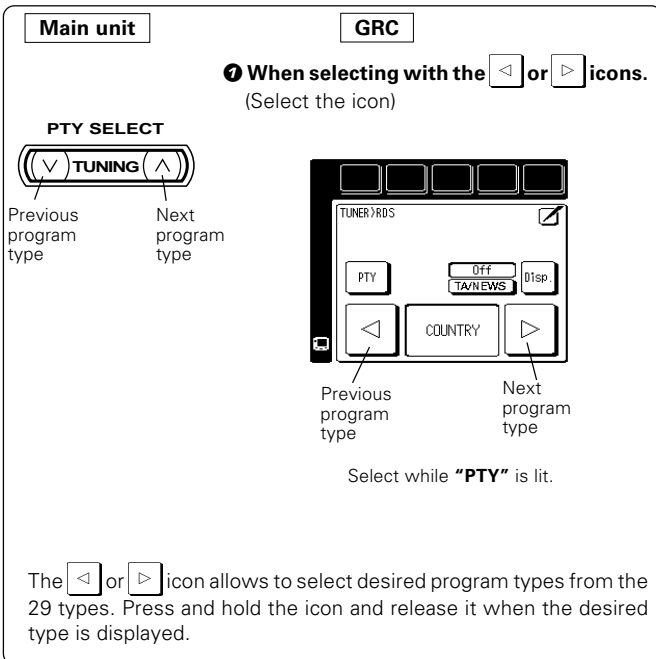

Program type table

	Program Type Name	Display
	No program type or undefined	NONE
(∨) DOWN ↑ DOWN ↑ (^) UP	Pop Music	POP M
	Rock Music	ROCK M
	Easy Listening Music	EASY M
	Light Classical	LIGHT M
	Serious Classical	CLASSICS
	Other Music	OTHER M
	News	NEWS
	Current Affairs	AFFAIRS
	Information	INFO
	Sport	SPORT
	Education	EDUCATE
	Drama	DRAMA
	Culture	CULTURE
	Science	SCIENCE
	Varied	VARIED
	Weather	WEATHER
	Finance	FINANCE
	Children's programs	CHILDREN
	Social affairs	SOCIAL
	Religion	RELIGION
	Phone in	PHONE IN
	Travel	TRAVEL
	Leisure	LEISURE
	Jazz Music	JAZZ
	Country Music	COUNTRY
	National Music	NATION M
	Oldies Music	OLDIES
	Folk Music	FOLK M
	Documentary	DOCUMENT

Continued to next page

3 Start the search.

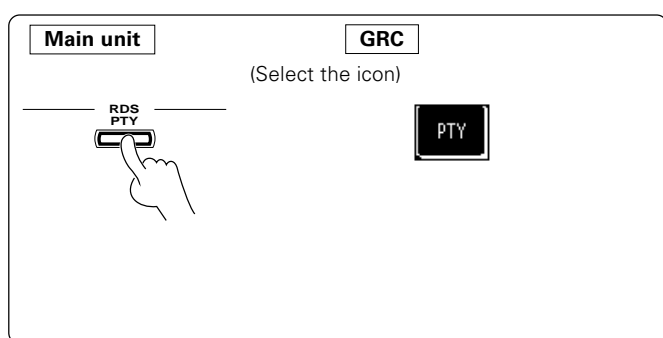

When searching for a Rock Music broadcast.

Display while the tuner is searching.



When a station is received.



To change to a different program type:

Repeat steps 1, 2, 3.

- If search is started while the program type is "NONE", it turns automatically into "POP M".
- No sound is heard while "PTY" is blinking.
- If a program of the desired type cannot be found, "NO PROG" is displayed, then after several seconds the display returns to the original display.
- When a station with the selected program type is searched, its reception starts and the type name display changes to the station name display.

To cancel search in the middle of it

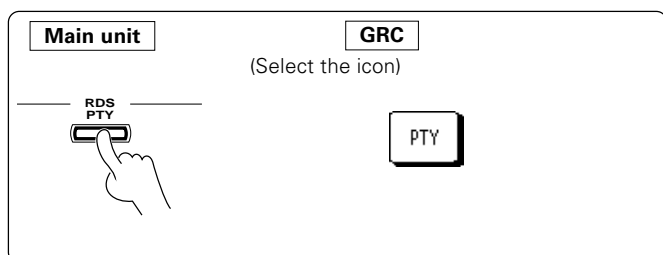

When the receiver is tuned to a RDS EON station (a station at which the EON indicator lights up), this function lets you set the receiver to automatically switch stations to receive news or traffic programs as they are broadcast. When the broadcast is over, the receiver returns to the original station automatically.

Preparation

Perform steps 1 to 3 of "Presetting RDS stations (AUTO MEMORY)". → 40



This step can be omitted if you have already executed the AUTO MEMORY procedure.

- The EON function cannot be used if all of the 40 preset stations have been stored using the procedure in "Storing radio stations manually in preset memory". Be sure to use the AUTO MEMORY function. → 41

Reserving the desired information (EON reservation)

1 Set the receiving band to FM.

Main unit

GRC

1 Select the Tuner input.
(Select the icon)

2 Display the Tuner operation menu.

3 Select the FM Band.
(Select the icon)

Main unit

Each press switches the indication.

- 1 TUNER (Frequency display)
- 2 CD
- 3 MD/TAPE 1
- 4 DVD/DVD 6ch INPUT
- 5 VIDEO 1
- 6 VIDEO 2

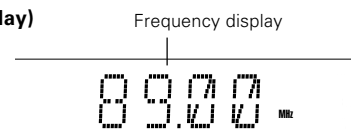

- The previously tuned frequency is displayed.

Each press switches the indication.

- 1 FM
 - 2 MW
 - 3 LW
- 1 FM (Australia only)
 - 2 AM (Australia only)



2 Tune to a preset RDS station.

Main unit

GRC

Select a station with which the EON and RDS indicators light.
(Select the icon)

- Radio stations can also be selected by pressing the [◀] or [▶] key.

Display when "TA" is selected

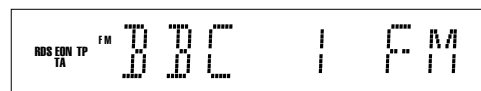

- If you want to reserve TA, receive a station with which the TP indicator lights.
- When "EON" does not light although an RDS station is received, that station is not transmitting EON data. Please select a different station.

TP (Traffic Program) indication

When the "TP" indicator is lit, this means that the presently-received station or a station in the same network is transmitting traffic information. When "TP" is displayed for the station being received, the traffic information of this station can be received without EON reservation.

Continued to next page

3 Select the desired kind of program.

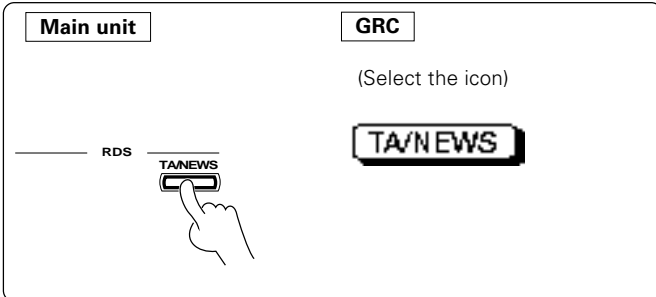

Display when "TA" is selected



"TP" lights for stations where TP (Traffic Program) can be received.

Each press switches the indication.

- ① TA (Traffic Announcement)
- ② NEWS (News)
- ③ TA/NEWS
- ④ OFF (EON reservation cancelled)

- "NO DATA" is displayed if this operation is attempted before performing the AUTO MEMORY operation. → 40

4 Wait for a reserved reception to start.

Leave the station with which the EON and RDS indicators light tuned in. The tuner stands by for the reception provided that the power is left ON.

To keep listening to a tuner station:

Receive a station with which the "EON" and "RDS" indicators light.

To listen to other source than tuner:

- ① While keeping the tuner tuned into a station with which the "EON" and "RDS" indicators light, select the desired source with the **INPUT SELECTOR**.
- ② Even when the **INPUT SELECTOR** is set to other source than **TUNER**, it is switched automatically to **TUNER** when EON-reserved broadcast starts.
In this period, the source pauses if the source selected in ① is **CD** or **MD**, or stops if it is **TAPE**.
- ③ When the EON-reserved reception completes, the **INPUT SELECTOR** returns to the previous input source.

- The EON overriding does not occur during recording.
- When the unit is in STANDBY mode, the EON function does not operate.
- When the transmission of the selected program contents ends in case of automatic reception with the EON function, return will be made to the status directly before operation of the EON function.

If the "EON" indicator does not light in steps 3 and 4 and the desired kind of information has already been selected, the information from only the station being received will be waited for.

To cancel EON reservation

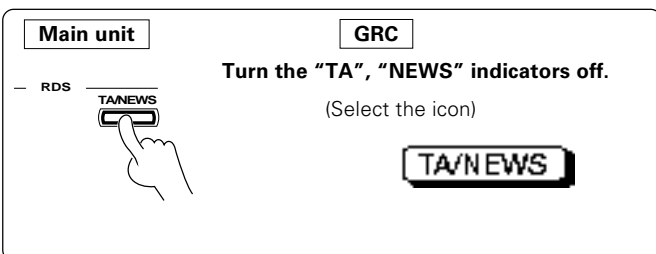

Each press switches the indication.

- ① TA
- ② NEWS
- ③ TA/NEWS
- ④ OFF



Should be OFF.

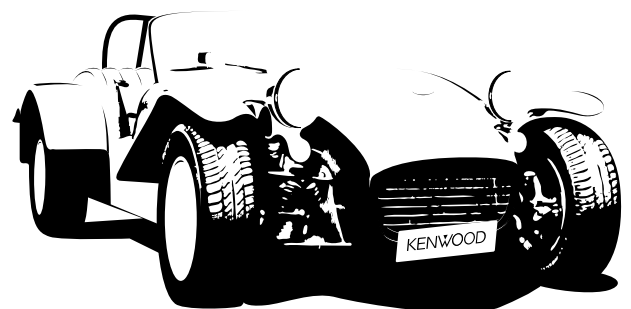

Ambience effects

48

This AV CONTROL CENTER incorporates 7 different sound modes to let you enjoy surround sound with a wide variety of program sources. The Dolby Digital (AC-3) and Dolby Pro Logic surround sound let you enjoy theater-like surround effects when you play Dolby Digital (AC-3) and Dolby Surround program sources (like Laserdiscs and DVDs). Dolby 3 Stereo creates a panoramic frontal sound field. The Digital Signal Processing (DSP) modes let you create a variety of different sonic environments from almost any type of program source.

To obtain the best possible surround sound, be sure to complete "Setup for surround play (SET UP)" before using the surround modes. → 23

Surround modes

DTS

The DTS multi-channel audio format is available on CD, LD and DVD software. DTS is a strictly digital format and can not be decoded inside most CD, LD or DVD players. For this reason, if you attempt to listen to DTS encoded software through the analog output of your CD, LD or DVD player, you will experience digital noise in most cases. This noise can be quite loud if the analog output is connected directly to a high power amplification system. Proper measures for playing the digital output as described below should be taken to avoid this situation. To enjoy DTS Digital Surround playback, an external 5.1 channel DTS Digital Surround decoder system or an amplifier with a built-in DTS Digital Surround decoder must be connected to the digital output (S/P DIF, AES/EBU or TosLink) of a CD, LD or DVD player.

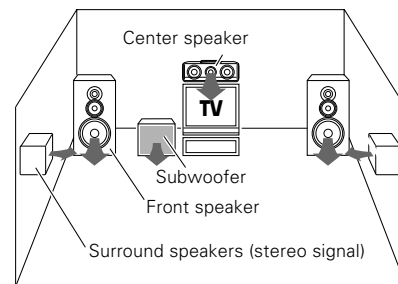

* Optional in this mode.

SRS Circle Surround

The Circle Surround System was developed to provide the highest level of sonic performance available in a Matrix system. Audio for music was not the focus for other multichannel formats and, as a result, there is a serious compromise in the performance of these systems. That is not to say that the Circle Surround system is only for music—other applications such as Cinema, Home Theater, multichannel broadcast, video tape and any other type of audio delivery can take advantage of the superior performance of Circle Surround. Since Circle Surround provides proper performance for music, the sonic impact for all other applications is also improved. Circle Surround 5.1 is capable of delivering true five-channel impact.

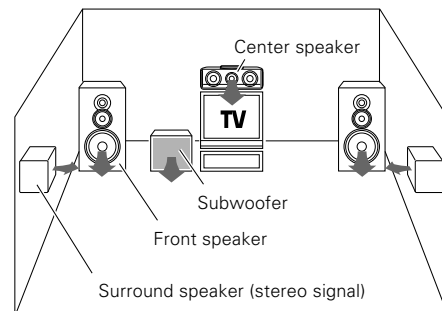

Dolby Digital (AC-3)

The Dolby Digital (AC-3) surround format lets you enjoy up to 5.1 channels of digital surround sound from Dolby Digital (AC-3) program sources (such as Laserdisc software marked ). Compared with previous Dolby surround, Dolby Digital (AC-3) provides even better sound quality, greater spatial accuracy, and improved dynamic range.

Note

Although a full set of speakers (front left, right, and center, Surround left and right, and a subwoofer) is required for true 5.1 channel Dolby Digital (AC-3) surround sound, this AV CONTROL CENTER lets you enjoy Dolby Digital (AC-3) (and Dolby Pro Logic) program sources, even if you connect only the front speakers.

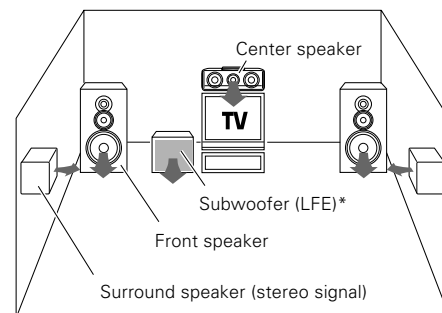

* LFE = Low Frequency Effects. This channel delivers separate non-directional bass signals to the subwoofer for more dynamic deep bass sound effects.

Although only Dolby Digital (AC-3) soundtracks incorporate a separate low frequency channel, connecting a subwoofer will also improve deep bass performance in the other surround modes.

Dolby Pro Logic

Dolby Pro Logic is a specially encoded 2 channel surround format designed to provide theater-like surround sound from Dolby Surround encoded sources (such as video and Laserdisc software marked ). This AV CONTROL CENTER is equipped with a Dolby Pro Logic surround decoder to let you enjoy the wide variety of currently available Dolby Surround home video software.

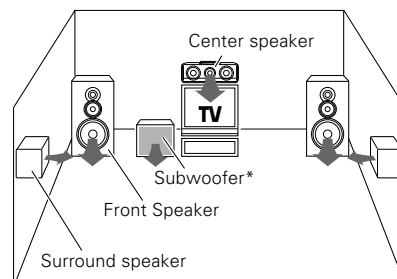

* Optional in this mode.

Dolby 3 Stereo

Dolby 3 Stereo is available for systems that do not have surround speakers. When in the Dolby 3 Stereo mode the surround information is redirected to the front left and right speakers. This mode is designed for use with Dolby Surround program sources, but can also improve sound field unity for programs that are not Dolby Surround encoded. Dialog positioning and sound image definition, however, may not be as accurate when used with programs that are not Dolby Surround encoded.

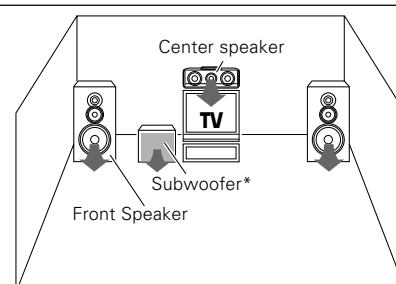

* Optional in this mode.

DSP mode

The **DSP** mode lets you add the atmosphere of a live concert or hall to PCM or analog of program source. These modes are particularly effective when used with stereo program sources, like CD, television, and FM radio. You might enjoy trying the **ARENA**, **THEATER**, **JAZZ CLUB** mode the next time you watch a concert or sporting event!

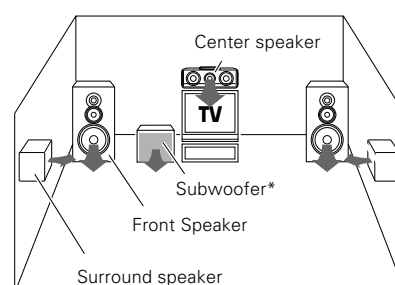

* Optional in this mode.

DVD 6-channel INPUT mode

Using a DVD player or the like equipped with six (5.1) output channels and the receiver, you can enjoy multi-channel encoded DVD source material in all its splendor. Since the source signals are digital and each channel is input independently, the resulting sound quality, sense of spaciousness, and dynamic range are superb.

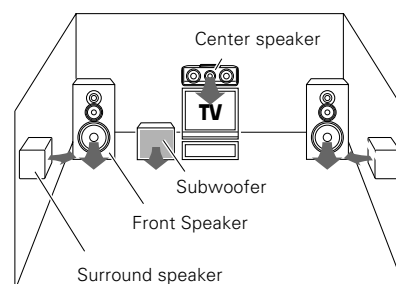

Recommended speaker installation



It is recommended that the surround speakers are installed straight to the left and right of the listening position or slightly behind, at a height of about 1 meter higher than the listener's ears.

The DTS compatible models can reproduce a CD, DVD or LD carrying the DTS mark. Dolby Digital (AC-3) can be used when playing DVD or LD software bearing the  mark and Dolby Digital (AC-3) format digital broadcasts (etc.). Dolby Pro Logic and Dolby 3 Stereo can be used when playing video, DVD, or LD software bearing the  mark. DSP modes can be used with any source except Dolby Digital and DTS.

Preparations

- Turn ON related components.
- Complete "Setup for surround play". → 23
- Set the **INPUT SELECTOR** to the component you wish to play back with surround sound.
- Use the **INPUT MODE** key to select the input mode (analog or digital) for the source you wish to play back. → 18

Sound may not be reproduced when the input signal and Listen mode are selected improperly.
How to select the digital input, analog input and LISTEN MODE. → 53

Surround play (LISTEN MODE)

1 Play video or music software.

2 Select the LISTEN MODE.

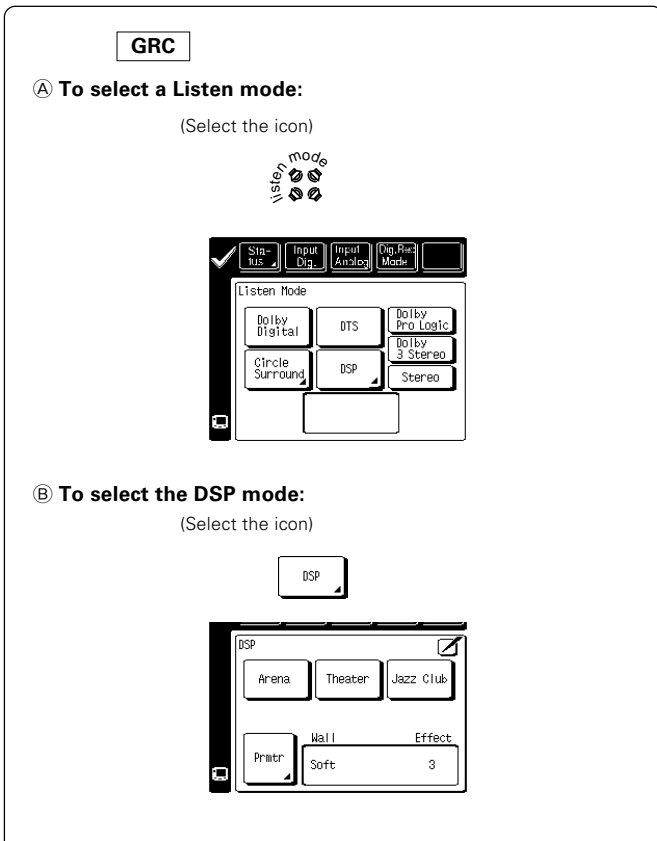
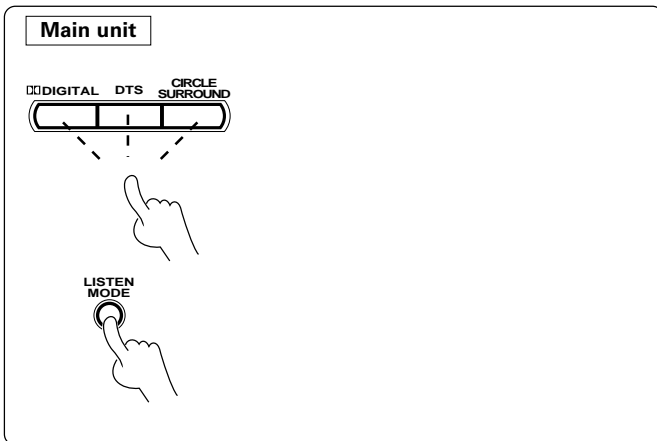

- The listening mode settings are stored separately for each input. If the input mode is set to digital auto ("AUTO SOUND" lights), the receiver selects the optimal listening mode automatically based on the type of input signal and the speaker settings.
- Note that the only listening mode settings that can be used for playback with the current input signal type and speaker settings are available.

When a Listen mode is selected:

- Select the Listen mode according to the software to be played.

Main unit

Display Listen mode

- DTS
- DOLBY DIGITAL
- CIRCLE SURROUND

Each press of the LISTEN MODE key switches the mode as follows.

- ➔ ① **PRO LOGIC** : Dolby Pro Logic
- ② **3 STEREO** : Dolby 3 Stereo
- ③ **CS CINEMA (Circle surround)** :
- ④ **CS MUSIC (Circle surround)** :
- ⑤ **ARENA (DSP)** : A lively feeling as felt in the frontmost seat in a concert arena.
- ⑥ **THEATER (DSP)** : A lively sound field like in a theater.
- ⑦ **JAZZ CLUB (DSP)** : Sound field of a jazz live house where cymbals sound sharply.
- ⑧ **STEREO** :

- ② cannot be selected when "C" has been set to Off in the Setup operation.
- ①, ③ and ④ cannot be selected when "LS/RS" has been set to Off in the Setup operation.
- The LISTEN MODE key is not accepted during headphone listening.
- Switching is not possible when the DVD 6ch INPUT is used.
- Noise will be produced when a DTS source is played by selecting the analog input.
- When playback is started, the sound may be cut or interrupted before the input source is confirmed as Dolby Digital.
- If a Dolby Digital signal having more channels than the maximum number of playback channels available using the receiver's current settings is input, the DOWNMIX indicator lights on the display and downmixing is performed to match the number of available channels.
 Example : If a Dolby Digital 5.1 signal is being input and the receiver is set to the stereo mode or if the center speaker channel is turned off.

Continued to next page

GRC

© To select the Circle surround mode:

(Select the icon)

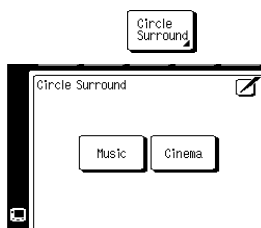

① Select the Circle surround type.

(Select the icon)

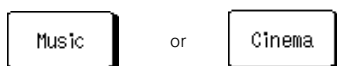

To end surround play

Main unit

GRC

① Select the "Stereo" icon.

(Select the icon)

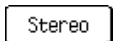
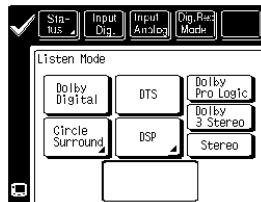

To select the DSP mode (DSP)

1 Select the DSP surround mode.

GRC

① **Select DSP.**
(Select the icon)

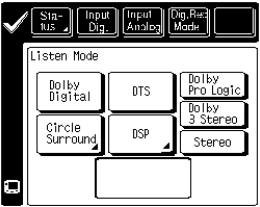

DSP

② **Select the "Arena" "Theater" "Jazz Club".**
(Select the icon)

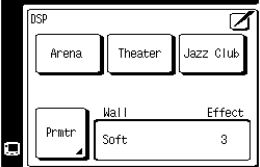

- This can be selected when the input signal is other than DTS, Dolby Digital (AC-3).

Main unit

Each press **LISTEN MODE** key switches the indication.

- ① **PRO LOGIC**
- ② **3 STEREO**
- ③ **CS CINEMA**
- ④ **CS MUSIC**
- ⑤ **ARENA**
- ⑥ **THEATER**
- ⑦ **JAZZ CLUB**
- ⑧ **STEREO**

- ② cannot be selected when "C" has been set to Off in the Setup operation.
- ①, ③ and ④ cannot be selected when "LS/RS" has been set to Off in the Setup operation.
- The **LISTEN MODE** key is not accepted during headphone listening.

- The effects of adjustments are applied equally to sound fields ⑤ to ⑦.
- Switching is not possible when the **DVD 6ch INPUT** is used. → 28

2 Select the adjustment parameter.

GRC

① **Display the setup screen.**

Prmr

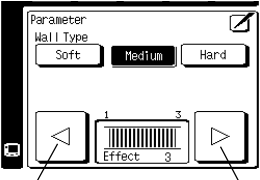

To decrease To increase

① **WALL TYPE**
Select "Soft", "Medium" or "Hard".

② **EFFECT LEVEL**
Adjust with keys ◀ and ▶.

- The EFFECT level can be adjusted between 1 and 3.

Listen mode selection

Surround play of digital input

INPUT selector	DVD (COAXIAL), CD (OPTICAL)		
Input signal	DTS	Dolby digital *1	PCM *1
Listen mode	① DTS ② STEREO	① DOLBY DIGITAL ② PRO LOGIC ③ 3 STEREO ④ STEREO	① PRO LOGIC ② 3 STEREO ③ CS CINEMA ④ CS MUSIC ⑤ ARENA (DSP) ⑥ THEATER (DSP) ⑦ JAZZ CLUB (DSP) ⑧ STEREO

Surround play of analog input

INPUT selector	DVD 6ch INPUT	MD/TAPE1, VIDEO1, 2, CD, TUNER
Input signal	Analog	Analog *1
Listen mode	The switching is not available when the DVD 6ch INPUT is selected. 	① PRO LOGIC ② 3 STEREO ③ CS CINEMA ④ CS MUSIC ⑤ ARENA (DSP) ⑥ THEATER (DSP) ⑦ JAZZ CLUB (DSP) ⑧ STEREO

*1: The possible selections may be limited depending on the played source and speaker setting.

Checking the current status (Status) (Remote control only)

GRC

① Select the "listen mode" icon.
(Select the icon)

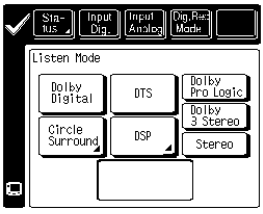
② Select the "Status" icon.
(Select the icon)

Input mode of the signal being input

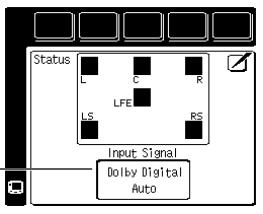
The encoding channel is displayed only during decoding of Dolby Digital/DTS. It is not displayed during Analog or PCM input operation.

Clock adjustment

54

This unit incorporates a clock function. Be sure to adjust the correct time before using the timer function.

The time display blinks after a power failure or when the power cord has been unplugged from the AC outlet and plugged in again. In such a case, adjust the clock again.

Clock adjustment (Main unit only)

1 Activate the clock adjustment mode.

Main unit

➊ Press the **CLOCK** key.

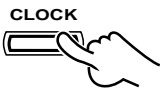

2 Enter the hour.

Main unit

➋ Press and hold the **CLOCK** key for more than 2 seconds. (The time display starts to blink.)

➌ Set the figure of hour.

➍ Press the **CLOCK** key.

MULTI CONTROL
LEVEL

To decrease the figure To increase the figure

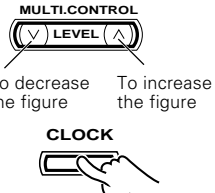

Example: Adjustment to 8:15

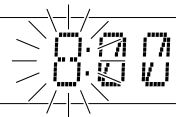

- Press the **CLOCK** key. The hour is entered and the minute display starts to blink.

3 Enter the minute.

Main unit

➎ Set the figure of minute.

➏ Press the **CLOCK** key.

MULTI CONTROL
LEVEL

To decrease the figure To increase the figure

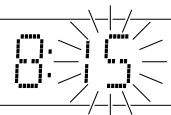
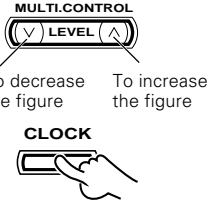

- If you make a mistake, restart from the beginning.
- To adjust correct time, press the **CLOCK** key at the same moment as a time announcement.

Displaying the Time

Each press of **DISPLAY** switches the displayed information alternately.

Main unit

CLOCK

GRC

SET UP

FL Disp.



To switch between the 12-hour/24-hour display (Main unit only)

Press and hold the **CLOCK** key

- ➊ 24-hour display
- ➋ 12-hour display

- From the second press, each press switches between 24h and 12h alternately.

Timer operation

Two 24-hour timer systems (TIMER 1, TIMER 2) (which can be used every day) and a sleep timer system (which works only once) are available.

In each of TIMER 1 and TIMER 2, the timer data including the operating period and played contents can be set and selected to be activated or not as required.

Timer reservation is possible for the two types TIMER 1 and TIMER 2 at the same time.

- Please make reservations with an interval of at least one minute, so that the operation times of TIMER 1 and TIMER 2 do not overlap.

Timer playback, timer recording (TIMER 1, TIMER 2)

With each of the two timer programs, a selected source can be played (or radio broadcast can be recorded) in the previously set time period.

Sleep timer

The unit is put to STANDBY mode automatically after the specified period has elapsed. → [58]

Timer programming

1 Make preparations for the play (recording).

- To listen to radio

The station should be preset before timer programming.

→ [40] → [41] → [42]

- To listen to CD

Insert a disc.
(Program playback is not possible.)

- To listen to MD

Insert a MD.

- To listen to DVD

Insert a disc.
(Program playback is not possible.)

- For broadcast recordings

Make preparations for recording. → [38]

2 Adjust the listening volume.

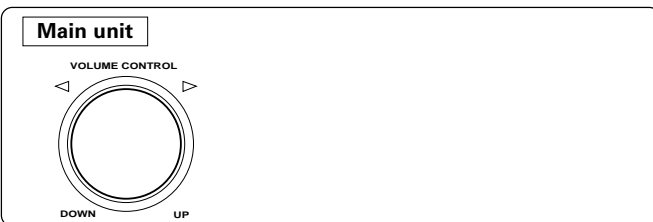

- The **VOLUME CONTROL** should be set to the desired volume while the unit is ON.
- The MUTE function is activated during timer recording.

3 Select a TIMER No.

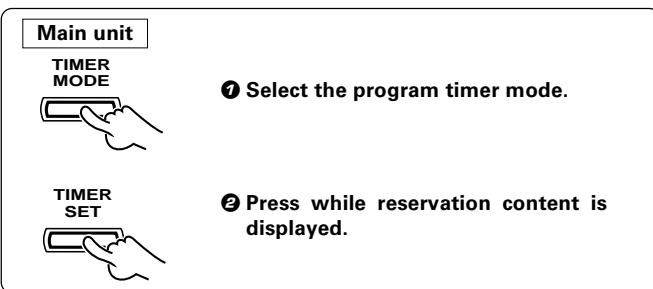

Each press of the key switches the **TIMER** numbers as follows.

- 1 **TIMER 1**
- 2 **TIMER 2**
- 3 **TIMER 1,2**
- 4 **OFF**

- The selected **TIMER No.** lights.
- If a previously programmed **TIMER No.** is selected, the contents will be replaced by the new contents programd.
- The timer programming operation is not possible when **TIMER 1,2** have already been selected.

4 Enter the ON time (Hour).

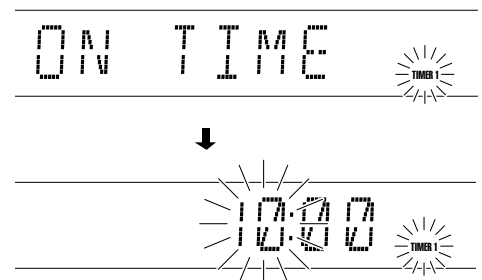
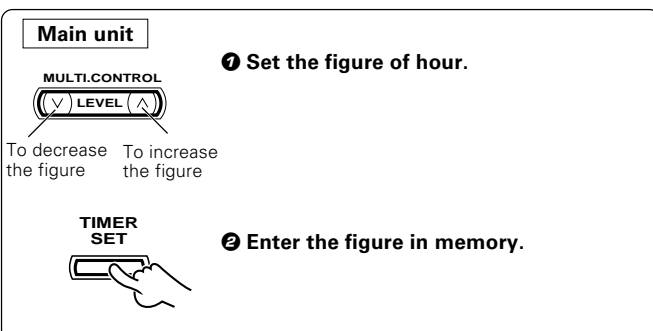

- If you make a mistake, restart from step 2.

5 Enter the On time (Minute).

Main unit

MULTI.CONTROL

 To decrease the figure To increase the figure

➊ Set the figure of minute.

TIMER SET

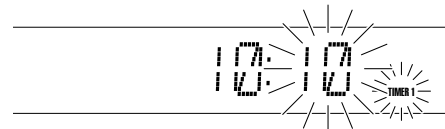
 ➋ Enter the figure in memory.

- After entering the figure of "hour" with the procedure in step 5, enter the figure of "minute" using the same procedure.



- If you make a mistake, restart from step 5.

6 Enter the OFF time (Hour).

Main unit

MULTI.CONTROL

 To decrease the figure To increase the figure

➊ Set the figure of hour.

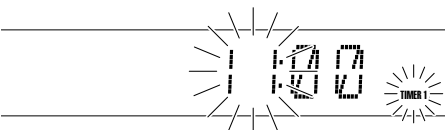
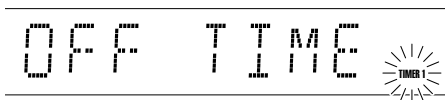
TIMER SET

 ➋ Enter the figure in memory.



- If you make a mistake, restart from step 6.

7 Enter the OFF time (Minute).

Main unit

MULTI.CONTROL

 To decrease the figure To increase the figure

➊ Set the figure of minute.

TIMER SET

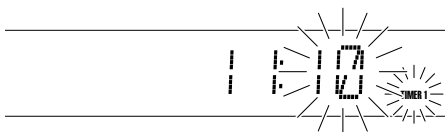
 ➋ Enter the figure in memory.

- After entering the figure of "hour" with the procedure in step 7, enter the figure of "minute" using the same procedure.



- If you make a mistake, restart from step 7.

Continued to next page

8 Make the desired reservation.

For timer playback

Main unit

1 Select the mode.

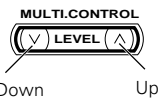

 ① **Select "PLAY"**
 (Each press alternates them.)
PLAY : At the ON time, playback starts.
REC

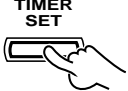

 ② **Enter it.**

PLAY

2 Select the input source.

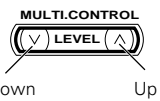

 ① **Select the source to be played.**
 (Each press switches the following.)
 ① **TUNER**
 ② **CD**
 ③ **MD/TAPE 1**
 ④ **DVD/DVD 6ch INPUT**

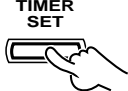

 ② **Enter it.**

Display when TUNER is selected

TUNER

3 Select the broadcast station (only when TUNER is selected above).

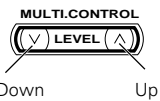

 ① **Select the preset station No.**

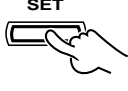

 ② **Enter it.**

FM 01 89.00

• The station to be received with timer must be preset beforehand.
 → 40 → 41 → 42

The reservation contents cannot be cleared. The contents are cleared only when they are changed.

Timer recording of broadcasts

Main unit

1 Select the mode.

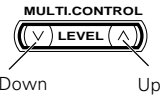

 ① **Select "REC".**
 (Each press alternates them.)
PLAY
REC



 ② **Enter it.**

2 Select the broadcast station.

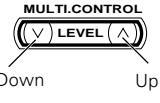

 ① **Select the preset station No.**

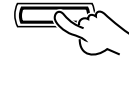

 ② **Enter it.**

Activating the timer

1 Activating the timer

Select the **TIMER No.** to be used.

Main unit

TIMER MODE



Each press of the key switches the **TIMER** numbers as follows.

- ① **TIMER 1** Execution of timer 1 only.
- ② **TIMER 2** Execution of timer 2 only.
- ③ **TIMER 1, 2** .. Execution of timers 1 and 2.
- ④ Off

- The selected **TIMER No.** lights.
- The timer will not function unless a **TIMER No.** is selected.

Continued to next page

Check the reservation content.

Main unit

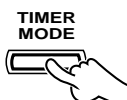

Select the TIMER number to be checked.

When timer operation is not required

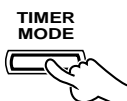

Press so that all TIMER No. indicators are OFF

To set the same timer program again

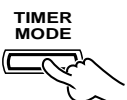

Press so that the desired TIMER No. indicators light.

Each press of the key switches the **TIMER** numbers as follows.

- ① **TIMER 1** (Contents of the timer 1 are displayed.)
- ② **TIMER 2** (Contents of the timer 2 are displayed.)
- ③ **TIMER 1, 2** .. (Contents of the timer 1 and timer 2 are displayed.)
- ④ Off

- The reserved contents will be displayed for 2 seconds per item. After this, the previous display content appears again.

To change the reserved contents

Restart the procedure of "Timer programming" from the beginning. → 55

Each press of the key switches the **TIMER** numbers as follows.

- ① **TIMER 1** (Only the timer 1 is carried out.)
- ② **TIMER 2** (Only the timer 2 is carried out.)
- ③ **TIMER 1,2** ... (Both timers 1 and 2 are carried out.)
- ④ Off (No timer operation is carried out.)

- The reservation contents are held in memory.

Each press of the key switches the **TIMER** numbers as follows.

- ① **TIMER 1** (Only the timer 1 is carried out.)
- ② **TIMER 2** (Only the timer 2 is carried out.)
- ③ **TIMER 1,2** ... (Both timers 1 and 2 are carried out.)
- ④ Off (No timer operation is carried out.)

- Also prepare the disc or tape and adjust the listening volume.

2 Set the I / ⏻ (ON/STANDBY) switch to **STANDBY**.

Main unit



Lights in green.

Sleep timer (Remote control only)

Setting the number of minutes until the unit is put to standby mode.

GRC

① Select the "sleep" icon

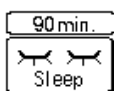

- This unit is turned STANDBY automatically after the set time has elapsed.
- While the **SLEEP** indicator is lit, the remaining sleep time is displayed in the Sleep area of the GRC display.

- Each press increases the time by 10 minutes. The maximum time that can be set is 90 minutes.

10→20→30...70→80→90→0→10→20...

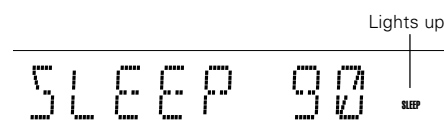

Duration for sleep timer.

To cancel

Turn **STANDBY** or select "Sleep" icon repeatedly until the sleep time is cancelled (0).



Maintenance

Maintenance of the unit

When the front panel or case becomes dirty, wipe with a soft, dry cloth. Do not use thinner, benzine, alcohol, etc. for these agents may cause discoloration.

In regard to contact cleaner

Do not use contact cleaners because it could cause a malfunction. Be specially careful not to use contact cleaners containing oil, for they may deform the plastic component.

Reference

Manufactured under license from Dolby Laboratories. "DOLBY", "Pro Logic" and the double-D symbol are trademarks of Dolby Laboratories. Confidential Unpublished Works. ©1992-1997 Dolby Laboratories. All rights reserved.

Manufactured under license from Digital Theater Systems, Inc. US Pat. No. 5,451,942 and other worldwide patents issues and pending. "DTS" and "DTS Digital Surround" are trademarks of Digital Theater Systems, Inc. © 1996 Digital Theater Systems, Inc. All rights reserved.



Circle Surround and the **CS** symbol are trademarks of SRS Labs, Inc. in the United States and selected foreign countries. Circle surround technology is incorporated under license from SRS Labs, Inc.

Memory backup function

Stored contents which are cleared immediately when power plug is unplugged from power outlet

Clock display

Stored contents which are cleared in at least a day after power plug is unplugged from power outlet

Amplifier section

ON/STANDBY status (ON or STANDBY)
 Input selection
 Video output
 Volume control value
 Tone bass level
 Tone treble level
 Input level
 Input selection mode

Surround section

LISTEN MODE
 Speaker setup
 Distance adjustment
 LEFT level
 RIGHT level
 CENTER level
 SURROUND level
 SUB WOOFER level
 MID NIGHT on/off

Tuner section

Receiving band
 Frequency
 Preset stations
 Program settings

In case of difficulty

What appears to be a malfunction may not always be serious. If your unit should not perform as expected, consult the table below to see if the problem can be corrected before seeking help from your dealer or service representative.

How to reset the microcomputer

The microcomputer may malfunction (impossibility of operation, erroneous display, etc.) when the power cord is unplugged and plugged in again while the unit is in ON mode with the I/⏻ key pressed or due to other external causes. In this case, execute the procedure on the right to reset the microcomputer and return the unit to the normal condition.

- ① Unplug the power cord from the wall outlet.
- ② While holding the I/⏻ (ON/STANDBY) key depressed, plug the power cord into the wall outlet again.

- Resetting the microcomputer clears the memory you entered and returns it to the initial condition when the unit left the factory.

Amplifier

Symptom	Cause	Remedy
Sound is not output or the volume level is low.	<ul style="list-style-type: none"> ● Connection cords are unplugged from the jacks. ● MUTE is ON. (The MUTE ON indicator is blinking) ● The TAPE 2/MONITOR is set to ON. ● The selected surround mode does not match the input signal. 	<ul style="list-style-type: none"> ● Connect them properly referring to "System connection". → 5 → 8 ● Press the MUTE key to OFF. → 28 ● Set the TAPE 2/MONITOR to OFF. ● Select the surround mode according to the input signal. → 53
Standby LED blinks and sound is not output.	<ul style="list-style-type: none"> ● Speaker cords are short-circuited. 	<ul style="list-style-type: none"> ● Unplug the AC cord, remove the short-circuiting and plug the AC cord again.
Sound is not output from the surround speaker and/or center speaker, or their sound is very small.	<ul style="list-style-type: none"> ● The surround speaker cords and/or center speaker cord are disconnected. ● The Surround play mode has not been engaged. ● The surround and center speaker levels are set to the minimum positions. 	<ul style="list-style-type: none"> ● Connect them by referring to the power amplifier's instruction manual. ● Set the presence mode. → 48 ● Adjust the surround and center speaker levels.
System control is not available when MD or TAPE 1 is selected.	<ul style="list-style-type: none"> ● "MD" or "TAPE 1" is not displayed. 	<ul style="list-style-type: none"> ● Set up the GRC unit properly. → 15
System control is not available when DVD or 6ch INPUT is selected.	<ul style="list-style-type: none"> ● "DVD" or "DVD 6ch INPUT" is not displayed. 	<ul style="list-style-type: none"> ● Switch the display to show "DVD" or "DVD 6ch INPUT". → 10 → 15
System control is impossible.	<ul style="list-style-type: none"> ● System control cords are connected incorrectly. 	<ul style="list-style-type: none"> ● Connect them correctly by referring to "System connection". → 5 → 8

Tuner

Symptom	Cause	Remedy
Radio stations cannot be received.	<ul style="list-style-type: none"> ● No antenna is connected. ● The broadcast band is not set properly. ● The frequency of the desired station is not tuned. 	<ul style="list-style-type: none"> ● Connect an antenna. → 9 ● Set the broadcast band properly. → 38 ● Tune the frequency of the desired station. → 38
Interference.	<ul style="list-style-type: none"> ● Noise due to ignition noise of an automobile. ● Noise due to an influence from an electric appliance. ● Noise due to a nearby TV set. 	<ul style="list-style-type: none"> ● Install the outdoor antenna away from the road. ● Turn off the power to the appliance. ● Install the system farther away from the TV set.
A station which was preset cannot be received by pressing the corresponding numeric key.	<ul style="list-style-type: none"> ● The preset memory was cleared because the power cord had been unplugged for a long period of time. ● The TUNER input is not selected. 	<ul style="list-style-type: none"> ● Preset the stations by auto memory again. → 40 ● Select the TUNER input.

Remote control unit

Symptom	Cause	Remedy
Remote control operation is not possible.	<ul style="list-style-type: none"> ● Batteries are exhausted. ● The remote control unit is too far away from the main system, controlling angle is too large, or there is an obstacle in between. ● The audio cords and system control cords are not connected properly. ● The source component to be operated does not contain the tape(s) or disc. 	<ul style="list-style-type: none"> ● Replace with new batteries. → 13 ● Operate the remote control unit within the controllable range. → 12 ● Connect properly referring to "System connection". → 5 → 8 ● Place the tape(s) or disc in the source component to be played.
The GRC screen is not displayed.	<ul style="list-style-type: none"> ● Batteries are exhausted. 	<ul style="list-style-type: none"> ● Replace with new batteries. → 13
Remote control operation is not available though the GRC screen is displayed.	<ul style="list-style-type: none"> ● The microcomputer is malfunctioning. 	<ul style="list-style-type: none"> ● Reset the GRC unit. → 14

Specifications

⚠ **Caution** : Read this page carefully to ensure safe operation.

For C-V751

Audio section

Total harmonic distortion (1 kHz, 1V)	0.01 %
Signal to noise ratio (IHF'66)	
CD	93 dB
Input sensitivity / impedance	
CD	200 mV / 47k Ω
Tone controls	
BASS	± 10 dB (at 100 Hz)
TREBLE	± 10 dB (at 10 kHz)
Output level / impedance	
TAPE REC	200 mV / 1 k Ω

Video section

VIDEO inputs / outputs (composite)	1 Vp-p/75 Ω
---------------------------------------	--------------------

Digital section

Sampling frequency	32 kHz, 44.1 kHz, 48 kHz
Digital input	
(coaxial)	0.5 Vp-p/75 Ω
(optical)	-15 dBm~21 dBm, 600 nm \pm 30 nm

FM Tuner section

Tuning frequency range	87.5 MHz~108 MHz
Usable sensitivity (DIN)	
MONO	1.2 μ V (at 75 Ω) / 13.2 dBf (40 kHz dev., S/N 26 dB)
STEREO	35 μ V (at 75 Ω) / 42 dBf (46 kHz dev., S/N 46 dB)
Signal to noise ratio (DIN weighted at 1 kHz, 40 kHz dev.)	
MONO	65 dB (65.2 dBf input)
STEREO	60 dB (65.2 dBf input)
Selectivity (DIN \pm 300 kHz)	64 dB
Stereo separation (DIN, 1 kHz)	36 dB
Frequency response	30 Hz~15 kHz, + 0.5 dB, - 3.0 dB

MW Tuner section

Tuning frequency range	531 kHz ~ 1,602 kHz
Usable sensitivity	
(30% mod., S/N 20 dB)	20 μ V / (700 μ V / m)
Signal to noise ratio	
(at 30% mod. 1mV input)	48 dB

LW Tuner section

Tuning frequency range	153 kHz ~ 279 kHz
Usable sensitivity	
(30% mod., S/N 20 dB)	35 μ V
Signal to noise ratio	
(at 30% mod. 1mV input)	45 dB

AM Tuner section (for Australia)

Tuning frequency range	531 kHz ~ 1,602 kHz
Usable sensitivity	
(30% mod., S/N 20 dB)	20 μ V / (700 μ V / m)
Signal to noise ratio	
(at 30% mod. 1mV input)	48 dB

General

⚠ Power consumption	35 W
AC outlet	
UN SWITCHED (for Australia)	1: (Total 100 W max)
UN SWITCHED (except Australia)	2: (Total 100 W max)
Dimensions	
W: 400 mm (15-3/4")	
H: 105 mm (4-1/8")	
D: 382 mm (15-1/16")	
Weight (net)	5.2 kg (11.4 lb)
Weight (net) (For Australia)	5.1 kg (11.2 lb)



1. KENWOOD follows a policy of continuous advancements in development. For reason specifications may be changed without notice.
2. The full performance may not be exhibited in an extremely cold location (under a water-freezing temperature).

KENWOOD

For your records

Record the serial number, found on the back of the unit, in the spaces designated on the warranty card, and in the space provided below. Refer to the model and serial numbers whenever you call upon your dealer for information or service on this product.

Model _____ Serial Number _____

Free Manuals Download Website

<http://myh66.com>

<http://usermanuals.us>

<http://www.somanuals.com>

<http://www.4manuals.cc>

<http://www.manual-lib.com>

<http://www.404manual.com>

<http://www.luxmanual.com>

<http://aubethermostatmanual.com>

Golf course search by state

<http://golfingnear.com>

Email search by domain

<http://emailbydomain.com>

Auto manuals search

<http://auto.somanuals.com>

TV manuals search

<http://tv.somanuals.com>