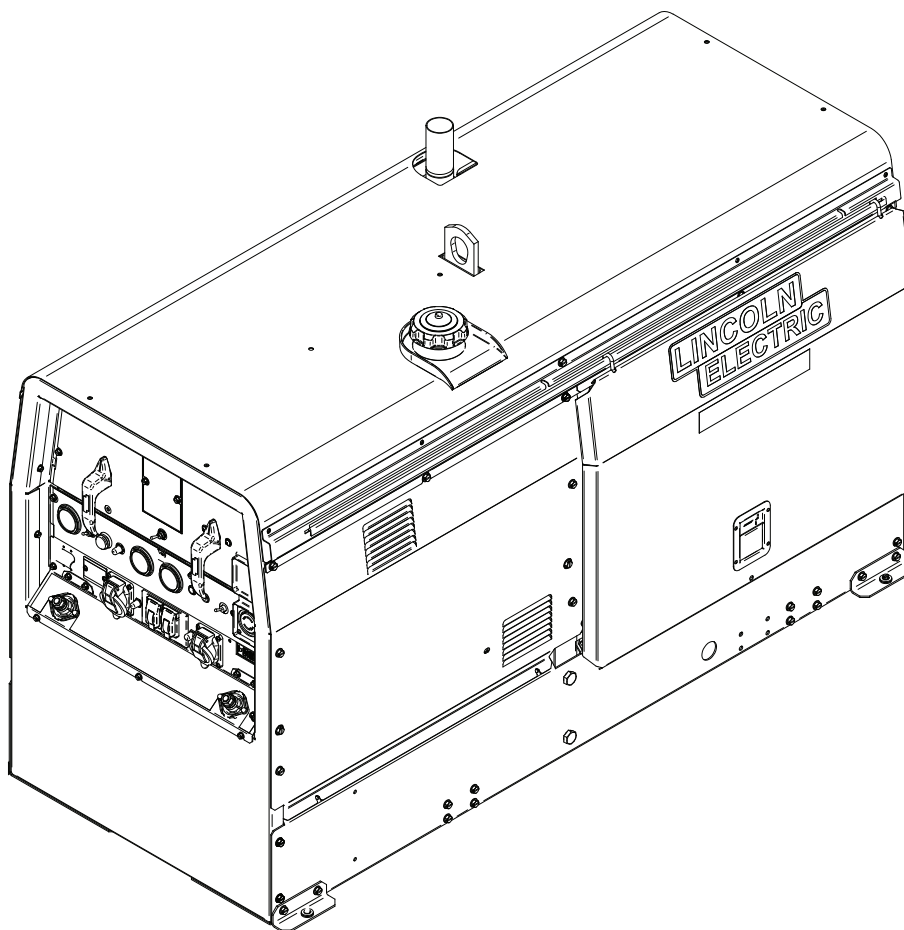

BIG RED™ 600For use with machines having Code Numbers: **11599****Safety Depends on You**

Lincoln arc welding and cutting equipment is designed and built with safety in mind. However, your overall safety can be increased by proper installation ... and thoughtful operation on your part. **DO NOT INSTALL, OPERATE OR REPAIR THIS EQUIPMENT WITHOUT READING THIS MANUAL AND THE SAFETY PRECAUTIONS CONTAINED THROUGHOUT.** And, most importantly, think before you act and be careful.

**OPERATOR'S MANUAL****LINCOLN®
ELECTRIC**

Copyright © Lincoln Global Inc.

- World's Leader in Welding and Cutting Products •
- Sales and Service through Subsidiaries and Distributors Worldwide •

Cleveland, Ohio 44117-1199 U.S.A. TEL: 216.481.8100 FAX: 216.486.1751 WEB SITE: www.lincolnelectric.comDownload from www.Somanuals.com. All Manuals Search And Download.

⚠ WARNING

⚠ CALIFORNIA PROPOSITION 65 WARNINGS ⚠

Diesel engine exhaust and some of its constituents are known to the State of California to cause cancer, birth defects, and other reproductive harm.

The Above For Diesel Engines

The engine exhaust from this product contains chemicals known to the State of California to cause cancer, birth defects, or other reproductive harm.

The Above For Gasoline Engines

ARC WELDING CAN BE HAZARDOUS. PROTECT YOURSELF AND OTHERS FROM POSSIBLE SERIOUS INJURY OR DEATH. KEEP CHILDREN AWAY. PACEMAKER WEARERS SHOULD CONSULT WITH THEIR DOCTOR BEFORE OPERATING.

Read and understand the following safety highlights. For additional safety information, it is strongly recommended that you purchase a copy of "Safety in Welding & Cutting - ANSI Standard Z49.1" from the American Welding Society, P.O. Box 351040, Miami, Florida 33135 or CSA Standard W117.2-1974. A Free copy of "Arc Welding Safety" booklet E205 is available from the Lincoln Electric Company, 22801 St. Clair Avenue, Cleveland, Ohio 44117-1199.

BE SURE THAT ALL INSTALLATION, OPERATION, MAINTENANCE AND REPAIR PROCEDURES ARE PERFORMED ONLY BY QUALIFIED INDIVIDUALS.



FOR ENGINE powered equipment.

1.a. Turn the engine off before troubleshooting and maintenance work unless the maintenance work requires it to be running.



1.b. Operate engines in open, well-ventilated areas or vent the engine exhaust fumes outdoors.



1.c. Do not add the fuel near an open flame welding arc or when the engine is running. Stop the engine and allow it to cool before refueling to prevent spilled fuel from vaporizing on contact with hot engine parts and igniting. Do not spill fuel when filling tank. If fuel is spilled, wipe it up and do not start engine until fumes have been eliminated.

1.d. Keep all equipment safety guards, covers and devices in position and in good repair. Keep hands, hair, clothing and tools away from V-belts, gears, fans and all other moving parts when starting, operating or repairing equipment.

1.e. In some cases it may be necessary to remove safety guards to perform required maintenance. Remove guards only when necessary and replace them when the maintenance requiring their removal is complete. Always use the greatest care when working near moving parts.



1.f. Do not put your hands near the engine fan. Do not attempt to override the governor or idler by pushing on the throttle control rods while the engine is running.

1.g. To prevent accidentally starting gasoline engines while turning the engine or welding generator during maintenance work, disconnect the spark plug wires, distributor cap or magneto wire as appropriate.



1.h. To avoid scalding, do not remove the radiator pressure cap when the engine is hot.



ELECTRIC AND MAGNETIC FIELDS may be dangerous

2.a. Electric current flowing through any conductor causes localized Electric and Magnetic Fields (EMF). Welding current creates EMF fields around welding cables and welding machines

2.b. EMF fields may interfere with some pacemakers, and welders having a pacemaker should consult their physician before welding.

2.c. Exposure to EMF fields in welding may have other health effects which are now not known.

2.d. All welders should use the following procedures in order to minimize exposure to EMF fields from the welding circuit:

2.d.1. Route the electrode and work cables together - Secure them with tape when possible.

2.d.2. Never coil the electrode lead around your body.

2.d.3. Do not place your body between the electrode and work cables. If the electrode cable is on your right side, the work cable should also be on your right side.

2.d.4. Connect the work cable to the workpiece as close as possible to the area being welded.

2.d.5. Do not work next to welding power source.

Mar '95



ELECTRIC SHOCK can kill.

3.a. The electrode and work (or ground) circuits are electrically "hot" when the welder is on. Do not touch these "hot" parts with your bare skin or wet clothing. Wear dry, hole-free gloves to insulate hands.

3.b. Insulate yourself from work and ground using dry insulation. Make certain the insulation is large enough to cover your full area of physical contact with work and ground.

In addition to the normal safety precautions, if welding must be performed under electrically hazardous conditions (in damp locations or while wearing wet clothing; on metal structures such as floors, gratings or scaffolds; when in cramped positions such as sitting, kneeling or lying, if there is a high risk of unavoidable or accidental contact with the workpiece or ground) use the following equipment:

- Semiautomatic DC Constant Voltage (Wire) Welder.
- DC Manual (Stick) Welder.
- AC Welder with Reduced Voltage Control.

3.c. In semiautomatic or automatic wire welding, the electrode, electrode reel, welding head, nozzle or semiautomatic welding gun are also electrically "hot".

3.d. Always be sure the work cable makes a good electrical connection with the metal being welded. The connection should be as close as possible to the area being welded.

3.e. Ground the work or metal to be welded to a good electrical (earth) ground.

3.f. Maintain the electrode holder, work clamp, welding cable and welding machine in good, safe operating condition. Replace damaged insulation.

3.g. Never dip the electrode in water for cooling.

3.h. Never simultaneously touch electrically "hot" parts of electrode holders connected to two welders because voltage between the two can be the total of the open circuit voltage of both welders.

3.i. When working above floor level, use a safety belt to protect yourself from a fall should you get a shock.

3.j. Also see Items 6.c. and 8.



ARC RAYS can burn.

4.a. Use a shield with the proper filter and cover plates to protect your eyes from sparks and the rays of the arc when welding or observing open arc welding. Headshield and filter lens should conform to ANSI Z87.1 standards.

4.b. Use suitable clothing made from durable flame-resistant material to protect your skin and that of your helpers from the arc rays.

4.c. Protect other nearby personnel with suitable, non-flammable screening and/or warn them not to watch the arc nor expose themselves to the arc rays or to hot spatter or metal.



FUMES AND GASES can be dangerous.

5.a. Welding may produce fumes and gases hazardous to health. Avoid breathing these fumes and gases. When welding, keep your head out of the fume. Use enough ventilation and/or exhaust at the arc to keep

fumes and gases away from the breathing zone. **When welding with electrodes which require special ventilation such as stainless or hard facing (see instructions on container or MSDS) or on lead or cadmium plated steel and other metals or coatings which produce highly toxic fumes, keep exposure as low as possible and within applicable OSHA PEL and ACGIH TLV limits using local exhaust or mechanical ventilation. In confined spaces or in some circumstances, outdoors, a respirator may be required. Additional precautions are also required when welding on galvanized steel.**

5. b. The operation of welding fume control equipment is affected by various factors including proper use and positioning of the equipment, maintenance of the equipment and the specific welding procedure and application involved. Worker exposure level should be checked upon installation and periodically thereafter to be certain it is within applicable OSHA PEL and ACGIH TLV limits.

5.c. Do not weld in locations near chlorinated hydrocarbon vapors coming from degreasing, cleaning or spraying operations. The heat and rays of the arc can react with solvent vapors to form phosgene, a highly toxic gas, and other irritating products.

5.d. Shielding gases used for arc welding can displace air and cause injury or death. Always use enough ventilation, especially in confined areas, to insure breathing air is safe.

5.e. Read and understand the manufacturer's instructions for this equipment and the consumables to be used, including the material safety data sheet (MSDS) and follow your employer's safety practices. MSDS forms are available from your welding distributor or from the manufacturer.

5.f. Also see item 1.b.

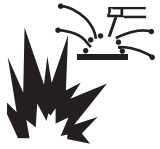

WELDING and CUTTING SPARKS can cause fire or explosion.

6.a. Remove fire hazards from the welding area. If this is not possible, cover them to prevent the welding sparks from starting a fire.

Remember that welding sparks and hot materials from welding can easily go through small cracks and openings to adjacent areas. Avoid welding near hydraulic lines. Have a fire extinguisher readily available.

- 6.b. Where compressed gases are to be used at the job site, special precautions should be used to prevent hazardous situations. Refer to "Safety in Welding and Cutting" (ANSI Standard Z49.1) and the operating information for the equipment being used.
- 6.c. When not welding, make certain no part of the electrode circuit is touching the work or ground. Accidental contact can cause overheating and create a fire hazard.
- 6.d. Do not heat, cut or weld tanks, drums or containers until the proper steps have been taken to insure that such procedures will not cause flammable or toxic vapors from substances inside. They can cause an explosion even though they have been "cleaned". For information, purchase "Recommended Safe Practices for the Preparation for Welding and Cutting of Containers and Piping That Have Held Hazardous Substances", AWS F4.1 from the American Welding Society (see address above).
- 6.e. Vent hollow castings or containers before heating, cutting or welding. They may explode.
- 6.f. Sparks and spatter are thrown from the welding arc. Wear oil free protective garments such as leather gloves, heavy shirt, cuffless trousers, high shoes and a cap over your hair. Wear ear plugs when welding out of position or in confined places. Always wear safety glasses with side shields when in a welding area.
- 6.g. Connect the work cable to the work as close to the welding area as practical. Work cables connected to the building framework or other locations away from the welding area increase the possibility of the welding current passing through lifting chains, crane cables or other alternate circuits. This can create fire hazards or overheat lifting chains or cables until they fail.
- 6.h. Also see item 1.c.
- 6.i. Read and follow NFPA 51B "Standard for Fire Prevention During Welding, Cutting and Other Hot Work", available from NFPA, 1 Batterymarch Park, PO box 9101, Quincy, Ma 022690-9101.
- 6.j. Do not use a welding power source for pipe thawing.



CYLINDER may explode if damaged.

7.a. Use only compressed gas cylinders containing the correct shielding gas for the process used and properly operating regulators designed for the gas and pressure used. All hoses, fittings, etc. should be suitable for the application and maintained in good condition.

- 7.b. Always keep cylinders in an upright position securely chained to an undercarriage or fixed support.
- 7.c. Cylinders should be located:
 - Away from areas where they may be struck or subjected to physical damage.
 - A safe distance from arc welding or cutting operations and any other source of heat, sparks, or flame.
- 7.d. Never allow the electrode, electrode holder or any other electrically "hot" parts to touch a cylinder.
- 7.e. Keep your head and face away from the cylinder valve outlet when opening the cylinder valve.
- 7.f. Valve protection caps should always be in place and hand tight except when the cylinder is in use or connected for use.
- 7.g. Read and follow the instructions on compressed gas cylinders, associated equipment, and CGA publication P-1, "Precautions for Safe Handling of Compressed Gases in Cylinders," available from the Compressed Gas Association 1235 Jefferson Davis Highway, Arlington, VA 22202.



FOR ELECTRICALLY powered equipment.

- 8.a. Turn off input power using the disconnect switch at the fuse box before working on the equipment.
- 8.b. Install equipment in accordance with the U.S. National Electrical Code, all local codes and the manufacturer's recommendations.
- 8.c. Ground the equipment in accordance with the U.S. National Electrical Code and the manufacturer's recommendations.

Refer to <http://www.lincolnelectric.com/safety> for additional safety information.

PRÉCAUTIONS DE SÛRETÉ

Pour votre propre protection lire et observer toutes les instructions et les précautions de sûreté spécifiques qui paraissent dans ce manuel aussi bien que les précautions de sûreté générales suivantes:

Sûreté Pour Soudage A L'Arc

1. Protégez-vous contre la secousse électrique:
 - a. Les circuits à l'électrode et à la pièce sont sous tension quand la machine à souder est en marche. Eviter toujours tout contact entre les parties sous tension et la peau nue ou les vêtements mouillés. Porter des gants secs et sans trous pour isoler les mains.
 - b. Faire très attention de bien s'isoler de la masse quand on soude dans des endroits humides, ou sur un plancher métallique ou des grilles métalliques, principalement dans les positions assis ou couché pour lesquelles une grande partie du corps peut être en contact avec la masse.
 - c. Maintenir le porte-électrode, la pince de masse, le câble de soudage et la machine à souder en bon et sûr état de fonctionnement.
 - d. Ne jamais plonger le porte-électrode dans l'eau pour le refroidir.
 - e. Ne jamais toucher simultanément les parties sous tension des porte-électrodes connectés à deux machines à souder parce que la tension entre les deux pinces peut être le total de la tension à vide des deux machines.
 - f. Si on utilise la machine à souder comme une source de courant pour soudage semi-automatique, ces précautions pour le porte-électrode s'appliquent aussi au pistolet de soudage.
2. Dans le cas de travail au dessus du niveau du sol, se protéger contre les chutes dans le cas où on recoit un choc. Ne jamais enrouler le câble-électrode autour de n'importe quelle partie du corps.
3. Un coup d'arc peut être plus sévère qu'un coup de soleil, donc:
 - a. Utiliser un bon masque avec un verre filtrant approprié ainsi qu'un verre blanc afin de se protéger les yeux du rayonnement de l'arc et des projections quand on soude ou quand on regarde l'arc.
 - b. Porter des vêtements convenables afin de protéger la peau de soudeur et des aides contre le rayonnement de l'arc.
 - c. Protéger l'autre personnel travaillant à proximité au soudage à l'aide d'écrans appropriés et non-inflammables.
4. Des gouttes de laitier en fusion sont émises de l'arc de soudage. Se protéger avec des vêtements de protection libres de l'huile, tels que les gants en cuir, chemise épaisse, pantalons sans revers, et chaussures montantes.
5. Toujours porter des lunettes de sécurité dans la zone de soudage. Utiliser des lunettes avec écrans latéraux dans les zones où l'on pique le laitier.
6. Eloigner les matériaux inflammables ou les recouvrir afin de prévenir tout risque d'incendie dû aux étincelles.
7. Quand on ne soude pas, poser la pince à un endroit isolé de la masse. Un court-circuit accidentel peut provoquer un échauffement et un risque d'incendie.
8. S'assurer que la masse est connectée le plus près possible de la zone de travail qu'il est pratique de le faire. Si on place la masse sur la charpente de la construction ou d'autres endroits éloignés de la zone de travail, on augmente le risque de voir passer le courant de soudage par les chaînes de levage, câbles de grue, ou autres circuits. Cela peut provoquer des risques d'incendie ou d'échauffement des chaînes et des câbles jusqu'à ce qu'ils se rompent.
9. Assurer une ventilation suffisante dans la zone de soudage. Ceci est particulièrement important pour le soudage de tôles galvanisées plombées, ou cadmiées ou tout autre métal qui produit des fumées toxiques.
10. Ne pas souder en présence de vapeurs de chlore provenant d'opérations de dégraissage, nettoyage ou pistolage. La chaleur ou les rayons de l'arc peuvent réagir avec les vapeurs du solvant pour produire du phosgène (gas fortement toxique) ou autres produits irritants.
11. Pour obtenir de plus amples renseignements sur la sûreté, voir le code "Code for safety in welding and cutting" CSA Standard W 117.2-1974.

PRÉCAUTIONS DE SÛRETÉ POUR LES MACHINES À SOUDER À TRANSFORMATEUR ET À REDRESSEUR

1. Relier à la terre le châssis du poste conformément au code de l'électricité et aux recommandations du fabricant. Le dispositif de montage ou la pièce à souder doit être branché à une bonne mise à la terre.
2. Autant que possible, l'installation et l'entretien du poste seront effectués par un électricien qualifié.
3. Avant de faire des travaux à l'intérieur de poste, la débrancher à l'interrupteur à la boîte de fusibles.
4. Garder tous les couvercles et dispositifs de sûreté à leur place.

Thank You

for selecting a **QUALITY** product by Lincoln Electric. We want you to take pride in operating this Lincoln Electric Company product
••• as much pride as we have in bringing this product to you!

CUSTOMER ASSISTANCE POLICY

The business of The Lincoln Electric Company is manufacturing and selling high quality welding equipment, consumables, and cutting equipment. Our challenge is to meet the needs of our customers and to exceed their expectations. On occasion, purchasers may ask Lincoln Electric for advice or information about their use of our products. We respond to our customers based on the best information in our possession at that time. Lincoln Electric is not in a position to warrant or guarantee such advice, and assumes no liability, with respect to such information or advice. We expressly disclaim any warranty of any kind, including any warranty of fitness for any customer's particular purpose, with respect to such information or advice. As a matter of practical consideration, we also cannot assume any responsibility for updating or correcting any such information or advice once it has been given, nor does the provision of information or advice create, expand or alter any warranty with respect to the sale of our products.

Lincoln Electric is a responsive manufacturer, but the selection and use of specific products sold by Lincoln Electric is solely within the control of, and remains the sole responsibility of the customer. Many variables beyond the control of Lincoln Electric affect the results obtained in applying these types of fabrication methods and service requirements.

Subject to Change – This information is accurate to the best of our knowledge at the time of printing. Please refer to www.lincolnelectric.com for any updated information.

Please Examine Carton and Equipment For Damage Immediately

When this equipment is shipped, title passes to the purchaser upon receipt by the carrier. Consequently, Claims for material damaged in shipment must be made by the purchaser against the transportation company at the time the shipment is received.

Please record your equipment identification information below for future reference. This information can be found on your machine nameplate.

Product _____

Model Number _____

Code Number or Date Code _____

Serial Number _____

Date Purchased _____

Where Purchased _____

Whenever you request replacement parts or information on this equipment, always supply the information you have recorded above. The code number is especially important when identifying the correct replacement parts.

On-Line Product Registration

- Register your machine with Lincoln Electric either via fax or over the Internet.
 - For faxing: Complete the form on the back of the warranty statement included in the literature packet accompanying this machine and fax the form per the instructions printed on it.
 - For On-Line Registration: Go to our **WEB SITE at www.lincolnelectric.com**. Choose "Quick Links" and then "Product Registration". Please complete the form and submit your registration.

Read this Operators Manual completely before attempting to use this equipment. Save this manual and keep it handy for quick reference. Pay particular attention to the safety instructions we have provided for your protection. The level of seriousness to be applied to each is explained below:

WARNING

This statement appears where the information **must** be followed **exactly** to avoid **serious personal injury** or **loss of life**.

CAUTION

This statement appears where the information **must** be followed to avoid **minor personal injury** or **damage to this equipment**.

Installation	Section A
Technical Specifications	A-1
Safety Precautions	A-2
Location and Ventilation	A-2
Storing	A-2
Stacking	A-2
Angle of Operation	A-2
Lifting.....	A-2
High Altitude Operation	A-2
High temperature Operation.....	A-2
Towing.....	A-3
Vehicle Mounting.....	A-3
Pre-Operation Engine Service.....	A-3
Oil	A-3
Fuel	A-3
Engine Break-In	A-4
Engine Coolant.....	A-4
Battery Connection.....	A-4
Muffler Outlet Pipe	A-5
Spark Arrester	A-5
Welding Output Cables	A-5
Auxiliary Power Receptacles, Residual Device Ready, Standby Power Connections	A-6
Connection of Lincoln Electric Wire Feeders	A-7
<hr/>	
Operation	Section B
Safety Instructions.....	B-1
General Description.....	B-1
Recommended Applications.....	B-1
Controls and Settings	B-2
Welder Controls	B-2
Engine Controls.....	B-3
Auxiliary.....	B-3
Engine Operation	B-4
Starting the Engine.....	B-4
Cold Weather Starting and Operation	B-4
Stopping the Engine.....	B-4
Welding Operation.....	B-5
Stick	B-5
Arc Gouging	B-5
TIG Welding	B-6
Constant Current Operation with Lincoln Wire Feeder	B-7
Auxiliary Power.....	B-8
Simultaneous Welding and Power Loads	B-8
<hr/>	
Accessories	Section C
Optional Features	C-1

	Page
Maintenance	Section D
Safety Precautions	D-1
Routine and Periodic Engine Maintenance	D-1
Oil Filter Change	D-2
Air Filter Change	D-2
Fuel and Bleeding the Fuel System	D-2
Fuel Filters	D-3
Fuel Pre-Filter/Water Separator Assembly	D-3
Water Separator Element	D-3
Second Fuel Filter	D-4
Cooling System	D-4
Cooling Blower Belt.....	D-4
Battery Handling	D-4 thru D-5
Servicing Optional Spark Arrestor	D-5
Nameplates / Warning Decals	D-5
Welder / Generator Maintenance	D-6
Storage	D-6
Cleaning	D-6
Brush Removal and Replacement	D-6
GFCI Module Testing and Resetting Procedure	D-6
<hr/>	
Troubleshooting	Section E
Safety Precautions.....	E-1
How to Use Troubleshooting Guide.....	E-1
Troubleshooting Guide.....	E-2, E-3
<hr/>	
Diagrams	Section F
Instructions for Installing a Residual Current Device.....	F-1, F-2
Wiring Diagram	F-3
Dimension Print.....	F-4
<hr/>	
Parts List.....	P-619 SERIES
<hr/>	

TECHNICAL SPECIFICATIONS - BIG RED™ 600 (K2811-1)

INPUT - DIESEL ENGINE					
Make/Model	Description	Speed (RPM)	Displacement	Starting System	Capacities
Deutz F3L 912 Diesel Engine	3 cylinder 44HP (33 kw) @ 1800 RPM	Idle 1890	173 cu. in (2.83L)	12VDC battery & Starter	Fuel (20 US gal) 75.7L Oil: 9.5 QTS. 9.0L
		Full Load 1800	Bore x Stroke 3.94" x 4.72" (100mm x 120mm)		
RATED OUTPUT @ 104° F (40° C) - WELDER					
Welding Process	Welding Output Current/Voltage/Duty Cycle		Output Range Amps	Max. Weld OCV Voltage @ 1800RPM	
DC Constant Current	500A / 40V / 100%		65A TO 600A	90 Volts	
	550A / 34V / 60%				
TIG	600A / 30V / 40%		65A TO 250A	75 Volts	
	250A / 20V / 100%				
RATED OUTPUT @ 104° F (40° C) - GENERATOR					
Auxiliary Power ¹ Single Phase 60 Hz AC					
OUTLETS	VOLTS	AMPS	POWER		
1	120	20	2400 Watts		
1	120	15	1800 Watts		
1	240	15	3600 Watts		
RECEPTACLES AND CIRCUIT BREAKERS					
RECEPTACLES	AUXILIARY POWER CIRCUIT BREAKER		OTHER CIRCUIT BREAKERS		
1 - 120VAC Duplex NEMA(5-20R) GFCI protected	1 - 20 AMP for 120 VAC Duplex (NEMA)		20AMP for Battery Charging Circuit		
1 - 120VAC European (IEC-309)-GFCI protected	1 - 15 AMP for 120 VAC European (IEC-309)				
1 - 240VAC European (IEC-309)	1 - 15 AMP for 240 VAC European (IEC-309)				
PHYSICAL DIMENSIONS					
HEIGHT	WIDTH	DEPTH	WEIGHT		
36.87(2) in. 916.5 mm	28.28 in 718.3 mm	65.1 in. 1653.5 mm	1657 lbs. (752 kg.)		

1. Output rating in watts is equivalent to volt-amperes at unity power factor. Output voltage is within $\pm 10\%$ at all loads up to rated capacity. When welding, available auxiliary power will be reduced.

2. To Top of enclosure, add 8.28"(210.1mm) to top of exhaust pipe.

BIG RED™ 600



SAFETY PRECAUTION

Read this entire installation section before you start installation.

⚠ WARNING



ELECTRIC SHOCK can kill.

- Do not touch electrically live parts or electrode with skin or wet clothing.
- Insulate yourself from work and ground
- Always wear dry insulating gloves.



ENGINE EXHAUST can kill.

- Use in open, well ventilated areas or vent exhaust outside.



MOVING PARTS can injure.

- Do not operate with doors open or guards off.
- Stop engine before servicing.
- Keep away from moving parts.

See additional warning information at front of this operator's manual.

LOCATION AND VENTILATION

The welder should be located to provide an unrestricted flow of clean, cool air to the cooling air inlets and to avoid restricting the cooling air outlets. Also, locate the welder so that the engine exhaust fumes are properly vented to an outside area.

STORING

1. Store the machine in a cool, dry place when it is not in use. Protect it from dust and dirt. Keep it where it can't be accidentally damaged from construction activities, moving vehicles, and other hazards.
2. Drain the engine oil and refill with fresh 10W30 oil. Run the engine for about five minutes to circulate oil to all the parts. See the MAINTENANCE section of this manual for details on changing oil.
3. Remove the battery, recharge it, and adjust the electrolyte level. Store the battery in a dry, dark place.

STACKING

BIG RED™ 600 machines cannot be stacked.

ANGLE OF OPERATION

To achieve optimum engine performance the BIG RED™ 600 should be run in a level position. The maximum angle of operation for the Deutz engine is 30 degrees fore and aft, 40 degrees right and 45 degrees left. If the engine is to be operated at an angle, provisions must be made for checking and maintaining the oil level at the normal (FULL) oil capacity in the crankcase. When operating the welder at an angle, the effective fuel capacity will be slightly less than the amount specified.

LIFTING

The BIG RED™ 600 weighs approximately 1772lbs. (804kg.) with a full tank of fuel 1657lbs.(752kg) less fuel. A lift bail is mounted to the machine and should always be used when lifting the machine.

⚠ WARNING



FALLING EQUIPMENT can cause injury.

- Lift only with equipment of adequate lifting capacity.

- Be sure machine is stable when lifting.
- Do not lift this machine using lift bail if it is equipped with a heavy accessory such as trailer or gas cylinder.

- Do not lift machine if lift bail is damaged.

- Do not operate machine while suspended from lift bail.

HIGH ALTITUDE OPERATION

At higher altitudes, output derating may be necessary. For maximum rating, derate the welder output 5% for every 300 meters (984 ft.) above 1500 meters (4920 ft.). For output of 500A and below, derate the welder output 5% for every 300 meters (984 ft.) above 2100 meters (6888 ft.).

Contact a Deutz Service Representative for any engine adjustments that may be required.

HIGH TEMPERATURE OPERATION

WELDER OUTPUT RATINGS AT TEMPERATURES ABOVE 40°C			
AMPS	DUTY CYCLE	VOLTS	TEMPERATURE
450 DC	30%	38	55°C
500 DC	30%	40	50°C
550 DC	30%	34	45°C

BIG RED™ 600



TOWING

Use a recommended trailer for use with this equipment for road, in-plant and yard towing by a vehicle(1). If the user adapts a non-Lincoln trailer, he must assume responsibility that the method of attachment and usage does not result in a safety hazard or damage the welding equipment. Some of the factors to be considered are as follows:

1. Design capacity of trailer vs. weight of Lincoln equipment and likely additional attachments.
2. Proper support of, and attachment to, the base of the welding equipment so there will be no undue stress to the framework.
3. Proper placement of the equipment on the trailer to insure stability side to side and front to back when being moved and when standing by itself while being operated or serviced.
4. Typical conditions of use, i.e., travel speed; roughness of surface on which the trailer will be operated; environmental conditions; like maintenance.
5. Conformance with federal, state and local laws.(1)

(1) Consult applicable federal, state and local laws regarding specific requirements for use on public highways.

VEHICLE MOUNTING

⚠ WARNING

Improperly mounted concentrated loads may cause unstable vehicle handling and tires or other components to fail.

- Only transport this Equipment on serviceable vehicles which are rated and designed for such loads.
- Distribute, balance and secure loads so vehicle is stable under conditions of use.
- Do not exceed maximum rated loads for components such as suspension, axles and tires.
- Mount equipment base to metal bed or frame of vehicle.
- Follow vehicle manufacture's instructions.

PRE-OPERATION ENGINE SERVICE

READ the engine operating and maintenance instructions supplied with this machine.

⚠ WARNING



DIESEL FUEL can cause fire.

- Stop engine while fueling.**
- Do not smoke when fueling.
 - Keep sparks and flame away from tank.
 - Do not leave unattended while fueling.
 - Wipe up spilled fuel and allow fumes to clear before starting engine.
 - Do not overfill tank, fuel expansion may cause overflow.

DIESEL FUEL ONLY

OIL



The BIG RED™ 600 is shipped with the engine crankcase filled with high quality SAE 10W-30 oil (API class CD or better). Check the oil level before starting the engine. If it is not up to the full mark on the dip stick, add oil as required. Check the oil level every four hours of running time during the first 35 running hours. Refer to the engine Operator's Manual for specific oil recommendations and break-in information. The oil change interval is dependent on the quality of the oil and the operating environment. Refer to the engine Operator's Manual for the proper service and maintenance intervals. The machine is equipped with an oil drain valve.

FUEL

USE DIESEL FUEL ONLY



⚠ WARNING

- Fill the fuel tank with clean, fresh fuel. The capacity of the tank is 20 gals. (75.7 ltrs). When the fuel gauge reads empty the tank contains approximately 2 gals. (7.6ltrs.) of reserve fuel.

⚠ WARNING

NOTE: A fuel shut off valve is located on the pre-filter/sediment filter. Which should be in the closed position when the welder is not used for extended periods of time.

BIG RED™ 600



ENGINE BREAK-IN

Lincoln Electric selects high quality, heavy-duty industrial engines for the portable welding machines we offer. While it is normal to see a small amount of crankcase oil consumption during initial operation, excessive oil use, wetstacking (oil or tar like substance at the exhaust port), or excessive smoke is not normal.

Larger machines with a capacity of 350 amperes and higher, which are operated at low or no-load conditions for extended periods of time are especially susceptible to the conditions described above. To accomplish successful engine break-in, most diesel-powered equipment needs only to be run at a reasonably heavy load within the rating of the welder for some period of time during the engine's early life. However, if the welder is subjected to extensive light loading, occasional moderate to heavy loading of the engine may sometimes be necessary. Caution must be observed in correctly loading a diesel/generator unit.

1. Connect the welder output studs to a suitable resistive load bank. Note that any attempt to short the output studs by connecting the welding leads together, direct shorting of the output studs, or connecting the output leads to a length of steel will result in catastrophic damage to the generator and voids the warranty.
2. Set the welder controls for an output current and voltage within the welder rating and duty cycle. Note that any attempt to exceed the welder rating or duty cycle for any period of time will result in catastrophic damage to the generator and voids the warranty.
3. Periodically shut off the engine and check the crankcase oil level.

ENGINE COOLING SYSTEM

The Deutz engine is air cooled by a belt driven axial blower. The oil cooler and engine cooling fins should be blown out with compressed air or steam to maintain proper cooling (See the engine Owners Manual for procedures and frequency).

BATTERY CONNECTION

WARNING



GASES FROM BATTERY can explode.

- Keep sparks, flame and cigarettes away from battery.

To prevent EXPLOSION when:

- **INSTALLING A NEW BATTERY** — disconnect negative cable from old battery first and connect to new battery last.
- **CONNECTING A BATTERY CHARGER** — remove battery from welder by disconnecting negative cable first, then positive cable and battery clamp. When reinstalling, connect negative cable last. Keep well ventilated.
- **USING A BOOSTER** — connect positive lead to battery first then connect negative lead to negative battery lead at engine foot.



BATTERY ACID can burn eyes and skin.

- Wear gloves and eye protection and be careful when working near battery.
- Follow instructions printed on battery.

IMPORTANT: To prevent ELECTRICAL DAMAGE WHEN:

- a) Installing new batteries.
- b) Using a booster.

Use correct polarity — Negative Ground.

The BIG RED™ 600 is shipped with the negative battery cable disconnected. Before you operate the machine, make sure the Engine Switch is in the OFF position and attach the disconnected cable securely to the negative (-) battery terminal.

Remove the insulating cap from the negative battery terminal. Replace and tighten negative battery cable terminal.

NOTE: This machine is furnished with a wet charged battery; if unused for several months, the battery may require a booster charge. Be sure to use the correct polarity when charging the battery.

BIG RED™ 600



MUFFLER OUTLET PIPE

Remove the plastic plug covering the muffler outlet tube. Using the clamp provided secure the outlet pipe to the outlet tube with the pipe positioned such that it will direct the exhaust in the desired position.

SPARK ARRESTOR

Some federal, state or local laws may require that petrol or diesel engines be equipped with exhaust spark arrestors when they are operated in certain locations where unarrested sparks may present a fire hazard. The standard muffler included with this welder does not qualify as a spark arrestor. When required by local regulations, a suitable spark arrestor, must be installed and properly maintained.

CAUTION

An incorrect arrestor may lead to damage to the engine or adversely affect performance.

WELDING OUTPUT CABLES

With the engine off, connect the electrode and work cables to the output studs. The welding process dictates the polarity of the electrode cable. These connections should be checked periodically and tightened if necessary.

Listed in Table A.1 are copper cable sizes recommended for the rated current and duty cycle. Lengths stipulated are the distance from the welder to work and back to the welder again. Cable sizes are increased for greater lengths primarily for the purpose of minimizing cable voltage drop.

Table A.1 Combined Length of Electrode and Work Cables.

AMPS @100% Duty Cycle	TOTAL COMBINED LENGTH OF ELECTRODE AND WORK CABLES		
	Up to 150 ft. (Up to 45m)	150-200 ft. (45-60m)	200-250 ft. (60-75m)
500	3/0 AWG 95mm ²	3/0 AWG 95mm ²	4/0 AWG 120mm ²

MACHINE GROUNDING

Because this portable engine driven welder creates its own power, it is not necessary to connect its frame to an earth ground, unless the machine is connected to premises wiring (home, shop, etc.).

To prevent dangerous electric shock, other equipment powered by this engine driven welder must:

a) be grounded to the frame of the welder using a grounding type plug,

or

b) be double insulated.

When this welder is mounted on a truck or trailer, its frame must be securely connected to the metal frame of the vehicle. When this engine driven welder is connected to premises wiring such as that in a home or shop, its frame must be connected to the system earth ground. See further connection instructions in the section entitled "Standby Power Connections" as well as the article on grounding in the latest National Electrical Code and the local codes.

In general, if the machine is to be grounded, it should be connected with a #8 or larger copper wire to a solid earth ground such as a metal ground stake going into the ground for at least 10 Feet or to the metal framework of a building which has been effectively grounded. The National Electric Code lists a number of alternate means of grounding electrical equipment. A machine grounding stud marked with the symbol is provided on the front of the welder.

AUXILIARY POWER RECEPTACLES

The auxiliary power of the BIG RED™ 600 consists of Single Phase 60Hz Power. Out put Voltage is within +/- 10% at loads up to rated capacity.

One 120VAC NEMA (5-20R) 20 amp duplex receptacle is protected by a 20 amp circuit breaker that provides 2400 watts Peak / 2400 watts Continuous power. Maximum current is 20 amps total.

One 120VAC European (IEC-309) 16 amp receptacle is protected by a 15 amp circuit breaker that provides 1800 watts Peak / 1800 watts Continuous power. Maximum current is 15 amps.

One 240VAC European (IEC-309) 16 amp receptacle is protected by a 15 amp 2-pole circuit breaker that provides 3600 watts Peak / 3600 watts Continuous power. The 2-pole circuit breaker disconnects both hot leads at the same time. Maximum current is 15 amps.

120 V RECEPTACLES

A GFCI module protects, the two 120V Auxiliary Power receptacles. A GFCI (Ground Fault Circuit Interrupter) electrical receptacle is a device to protect against electric shock should a piece of defective equipment connected to it develop a ground fault. If this situation should occur, the GFCI module will trip, removing voltage from the output of the receptacle. If a GFCI module is tripped see the MAINTENANCE section for detailed information on testing and resetting it. A GFCI module should be properly tested at least once every month.

The 120 V auxiliary power receptacles should only be used with three wire grounded type plugs or approved double insulated tools with two wire plugs. The current rating of any plug used with the system must be at least equal to the current capacity of the associated receptacle.

RESIDUAL CURRENT DEVICE READY

The BIG RED™ 600 is configured to allow for the addition of a Residual Current Device (RCD) to protect the 240V Single Phase Receptacle. The auxiliary power area on the front panel of the BIG RED™ 600 has a hole sized and shaped to accept a typical 2-pole (RCD) along with a protective rubber boot. A cover plate with a label "RCD READY" covers the hole and secures a mounting bracket on the backside of the panel.

Note: The (RCD) should be rated for at least 15 amps.

There are many suppliers of RCD's. One example is Allen Bradley, part number 1492-RCD2A40.

The protective boot can be obtained from: APM-Hexseal, part number HE-1035

See **Section F** Diagrams of this Operator's Manual for instructions on installing an RCD and protective rubber boot.

STANDBY POWER CONNECTIONS

The BIG RED™ 600 is suitable for temporary, standby or emergency power using the engine manufacturer's recommended maintenance schedule.

The BIG RED™ 600 can be permanently installed as a standby power unit for 240 VAC(60Hz). Connections must be made by a licensed electrician who can determine how the 120/240 VAC power can be adapted to the particular installation and comply with all applicable electrical codes.

Take necessary steps to assure load is limited to the capacity of the BIG RED™ 600

WARNING

- **Only a licensed, certified, trained electrician should install the machine to a premises or residential electrical system. Be certain that:**
- **The installation complies with the National Electrical Code and all other applicable electrical codes.**
- **The premises is isolated and no feedback into the utility system can occur. Certain state and local laws require the premises to be isolated before the generator is linked to the premises. Check your state and local requirements.**

BIG RED™ 600



CONNECTION OF LINCOLN ELECTRIC WIRE FEEDERS

⚠ WARNING

Shut off Welder before making any electrical connections.

The LN-15™ Across-the-Arc model, LN-25™ with or without an internal contactor, and LN-25™ PRO may be used with the BIG RED™ 600.

1. Shut the welder off.
2. For electrode Positive, connect the electrode cable from the wire feeder to the "+" terminal of the welder and work cable to the "-" terminal of the welder. For electrode Negative, connect the electrode cable from the wire feeder to the "-" terminal of the welder and work cable to the "+" terminal of the welder.
3. Set the CV/CC mode of the wire feeder to CC. (Refer to wire feeder operator manual for details on setting the wire feeder in the CC mode and for setting welding parameters).
4. Attach the single lead from the front of the wire feeder to work using the spring clip at the end of the lead. This is a sense lead to supply current to the wire feeder motor; it does not carry welding current.
5. When the gun trigger is closed, the current sensing circuit will cause the wire to begin to feed and the welding process is started.

NOTE: The LN-25™ (K444-1) Remote Control Module (K431) and Remote Cable (K432) cannot be used with the BIG RED™ 600 See the appropriate connection diagram in **Section F**.

⚠ WARNING

If you are using an LN-25™ without an internal contactor, the electrode will be energized when the BIG RED™ 600 is started.

The Wire Feeder sensor has full OCV potential between spring clip and work return. Turn machine off when attaching spring clip.

Lincoln Electric does NOT recommend constant current semiautomatic welding for applications which need to meet specified weld metal chemical or mechanical property requirements or weld quality requirements.

FIGURE A-1

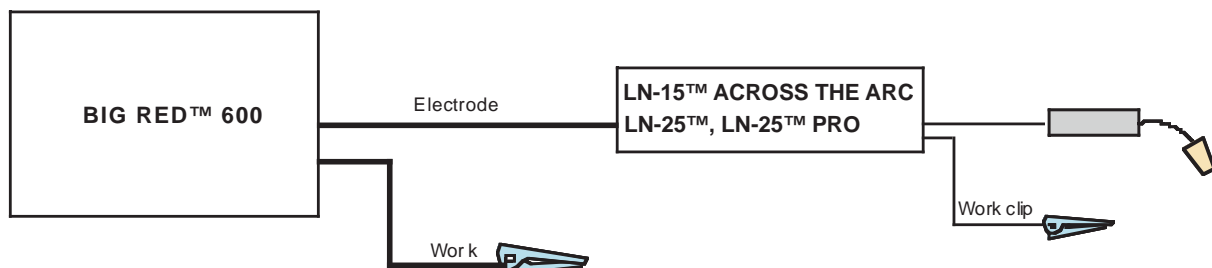

BIG RED™ 600



SAFETY INSTRUCTIONS

Read and understand this entire section before operating your BIG RED™ 600.

WARNING

Do not attempt to use this equipment until you have thoroughly read all operating and maintenance manuals supplied with your machine. They include important safety precautions, detailed engine starting, operating and maintenance instructions and parts lists.

ELECTRIC SHOCK can kill.



- Do not touch electrically live parts such as output terminals or internal wiring.
- Insulate yourself from the work and ground.

- Always wear dry insulating gloves.

ENGINE EXHAUST can kill.



- Use in open, well ventilated areas or vent exhaust outside
- Do not stack anything near the engine.

MOVING PARTS can injure.



- Do not operate with doors open or guards off.
- Stop engine before servicing.

- Keep away from moving parts

Only qualified personnel should operate this equipment.

ADDITIONAL SAFETY PRECAUTIONS

Always operate the welder with the hinged door closed and the side panels in place as these provide maximum protection from moving parts and insure proper cooling air flow.

GENERAL DESCRIPTION

The BIG RED™ 600 is a diesel engine driven welder, offering reliable DC arc welding performance, with outstanding arc characteristics for all welding applications. The BIG RED™ 600 is both a rugged three cylinder, diesel engine driven 600 amp DC arc welder and 3.6 KW AC power generator. This powerful generator can be used to provide electricity for lights, power tools, etc.

The BIG RED™ 600 delivers ideal DC arc characteristic for each welding process. Stick electrode welding, Scratch-Start TIG, or carbon arc gouging, to make the BIG RED™ 600 the ideal all purpose engine driven welder for on-site work.

The BIG RED™ 600 has “no PC Boards” and “no electronics”.

The BIG RED™ 600 is service friendly with a minimal number of major parts, simplifying in field servicing of the BIG RED™ 600. The generator is a dual stator and rotor design with two sealed bearings for maintenance free service. The rotors are copper wound design with two slip rings and brushes. The stators are wound entirely with heavy gauge copper wire and insulated with NEMA class F insulation material. The stator is then impregnated with three layers of high quality varnish. After the stator is assembled using tie bars, the entire assembly is covered with an environmentally protective coating. These measures insure trouble-free operation in the harshest environments.

RECOMMENDED APPLICATIONS

WELDER

The BIG RED™ 600 provides constant current DC welding output for stick (SMAW) and TIG (GTAW) welding (scratch start). In addition the Big Red can be used for Arc Gouging with carbons up to 9.5 mm (3/8”) diameter.

The BIG RED™ 600 is **not recommended** for pipe thawing.

GENERATOR

The BIG RED™ 600 provides smooth output for auxiliary power and emergency standby power. The auxiliary power is independent of the welding power and thus not effected by the weld control settings. Full power is available provided welding output is below 200 amps. Above 200 amps refer to the Simultaneous Welding and Auxiliary Power chart in the operation section of this manual.

BIG RED™ 600



CONTROLS AND SETTINGS

All welder and engine controls are located on the case front panel. Refer to Figure B.1 and the explanations that follow.

Figure B.1 Case Front Panel Controls

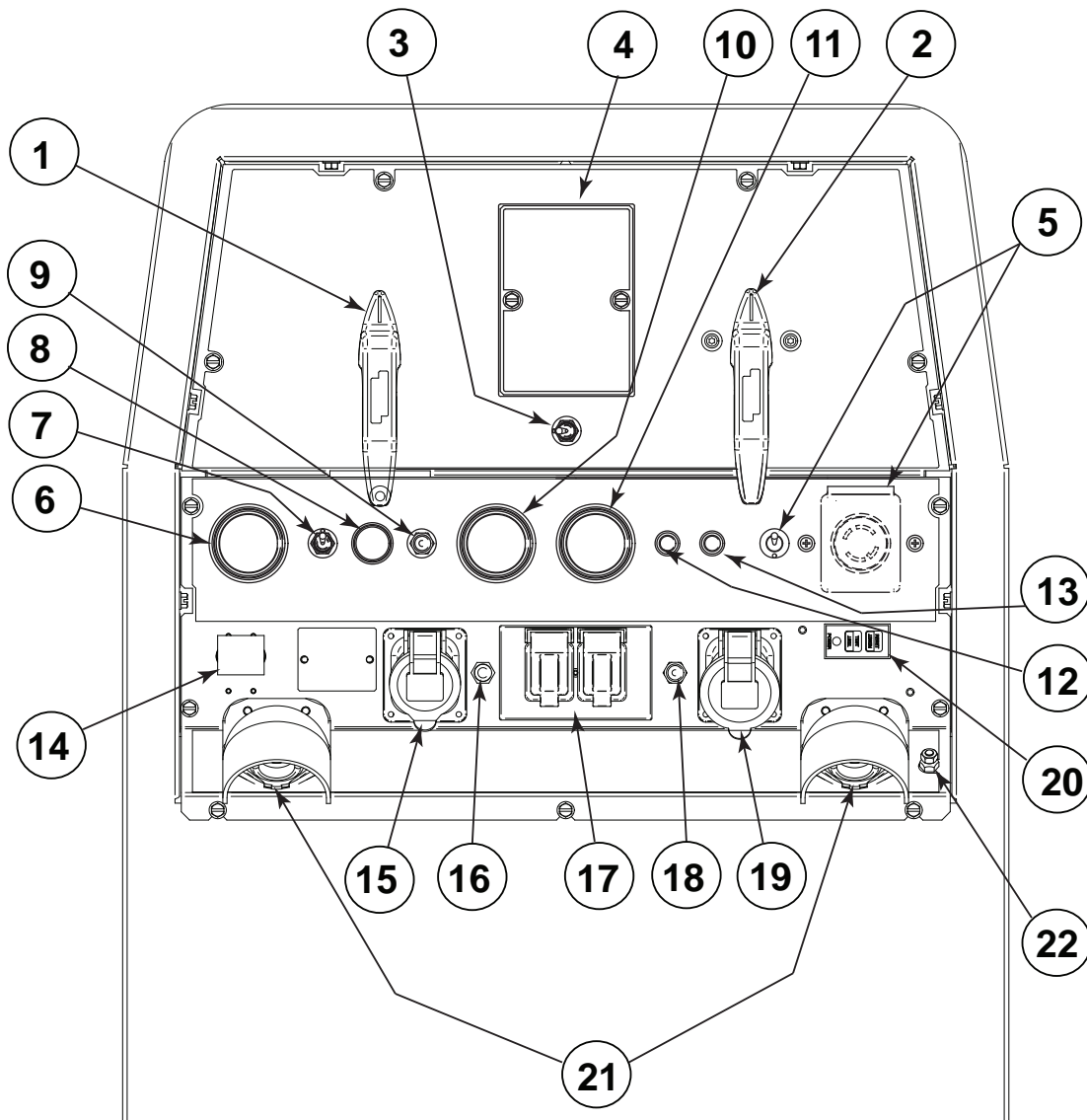

WELDING CONTROLS (Items 1-5)

1. OUTPUT RANGE SELECTOR SWITCH

A 5 position switch that provides 5 overlapping output current settings:

- 65 - 115
- 105 - 220
- 150 - 330
- 200 - 435
- 300 – Maximum

Note: Do not switch while welding

2. OUTPUT CONTROL

Provides fine adjustment of the current and open circuit voltage from minimum to maximum within each Range.

“1” is minimum and “10” is maximum.

3. WELD MODE SELECTOR SWITCH

Provides selection of either Stick / Arc Gouging Mode or TIG Mode.

4. VOLT/AMP METERS (optional)

Optional analog volt and amp meter kit available for easy installation into front panel.

(See Accessory Section For “K” number)

BIG RED™ 600



5. LOCAL / REMOTE CONTROL SWITCH and REMOTE RECEPTACLE

The toggle switch provides the option of controlling the welding output at the control panel or remotely. For control at the control panel set the switch in the "LOCAL" position. For remote control set the switch in the "REMOTE" position. The receptacle is for attaching an optional remote control equipment. (See Accessory Section For "K" number)

ENGINE CONTROLS (Items 6 Through to 13)

6. ENGINE HOUR METER / FUEL GAUGE



Combination hour meter fuel level gauge. The hour meter displays the total time that the engine has been running. This meter is a useful indicator for scheduling preventive maintenance. The fuel gauge displays the level of diesel fuel in the fuel tank. The operator must watch the fuel level closely to prevent running out of fuel and possibly having to bleed the system.

7. RUN STOP SWITCH

The RUN position energizes the hold coil of the fuel solenoid, hour meter, and rotor flashing circuit. The STOP position stops the engine.

Note: Do not leave switch in RUN position when the engine is not running. In the RUN position the battery will be discharged.

8. START PUSH BUTTON



Energizes the starter motor to crank the engine. With the RUN / STOP switch in the RUN position, push and hold the Start button to crank the engine; release as the engine starts. Do not press while engine is running as this can cause damage to the ring gear and/or starter motor.

9. CIRCUIT BREAKER



The battery circuit breaker protects the engine circuitry that powers the three gauges, fuel/hours, temperature and pressure. It also protects the engine shutdown relay, timer delay relay, hot start relay hold solenoid, and flashing circuitry. When the circuit breaker opens because of a fault, the engine will crank but will not start.

10. OIL TEMPERATURE GAUGE



An indicator of engine oil temperature.

11. OIL PRESSURE GAUGE



An indicator of engine oil pressure.

12. ENGINE PROTECTION

A warning indicator light for high oil temperature or low oil pressure. The light remains off with proper oil temperature and proper oil pressure. If a fault is detected the light will turn on and the engine protection system will stop the engine. The light will remain on when the engine has been shut down. In order to try and re-start the engine the engine protection system must be reset by returning the RUN-STOP switch to the STOP position.

Note: The light remains off when the RUN-STOP switch is in the RUN position prior to starting the engine. However if the engine is not started within 60 seconds the light will come on. When this happens the RUN-STOP switch must be returned to the STOP position to reset the engine protection system and light.

13. BATTERY CHARGING LIGHT



An indicator light for low/no battery charging. The light is off when the battery charging system is functioning normally. If light turns on, the alternator or the voltage regulator may not be operating correctly or the cooling blower belt may be broken. The light will remain on when the engine is stopped and the RUN / STOP switch is in the RUN position.

AUXILIARY POWER (14-22)

14. CIRCUIT BREAKER

2-pole 15A rated. Provides overload protection for the 240VAC European (IEC-309) receptacle.

15. 240 VAC RECEPTACLE

European (IEC-309) receptacle rated up to 15 amps and is IP44 rated.

Note: A space is provided on the panel for adding a 2-pole Residual Current Device (RCD) to protect the 240V receptacle. See Section F for instructions on installing an RCD.

16. CIRCUIT BREAKER

Single-pole 20A rated. Provides overload protection for the 120VAC (5-20R) NEMA Duplex Receptacle.

BIG RED™ 600



17. 120 VAC DUPLEX RECEPTACLE

Single-pole 20A rated. Provides overload protection for the 120VAC (5-20R) NEMA Duplex Receptacle.

18. CIRCUIT BREAKERS

Single pole 15A rated. Provides overload protection for the 120VAC European (IEC-309) receptacle.

19. 120 VAC RECEPTACLE

European (IEC-309) receptacle rated up to 15 amps and is IP44 rated. Receptacle is GFCI protected.

20. GFCI (Ground Fault Circuit Interrupter) Module

Protects both 120VAC Auxiliary Power receptacles.

If a GFCI Module is tripped, See the MAINTENANCE section for detailed information on testing and resetting the GFCI Module.

21. WELD OUTPUT TERMINALS + AND -

Covered terminals that provide welding connection points for the electrode and work cables.

22. GROUND STUD

Protects both 120VAC Auxiliary Power receptacles.

ENGINE OPERATION**STARTING THE ENGINE**

1. Open the engine compartment door and check that the fuel shut off valve located screwed into the fuel filter housing is in the open position (lever to be in line with the hose).
2. Check for proper oil level. Close engine compartment door.
3. Remove all plugs connected to the AC power receptacles.
4. Set the RUN/STOP switch to "RUN". Observe that the battery charging light is on and fuel is in the fuel tank (see fuel gauge).
5. Within 30 seconds, press and hold the engine START button until the engine starts.
6. Release the engine START button when the engine starts.
7. Check that the engine protection and battery charging lights are off. The engine protection light is on after starting, the engine will shutdown in a few seconds. Investigate any indicated problem.

8. Allow the engine to warm up for several minutes before applying a load. Allow a longer warm up time in cold weather.

COLD WEATHER STARTING

With a fully charged battery and the proper weight oil, the engine should start satisfactorily even down to about -15°C(5°F). If the engine must be frequently started below -15°C(5°F), it may be desirable to install additional starting aids. The use of No. 1D diesel fuel is recommended in place of No. 2D at temperatures below -5°C(23° F).

STOPPING THE ENGINE

Switch the RUN/STOP switch to "STOP". This turns off the voltage supplied to the shutdown solenoid. A backup shutdown can be accomplished by shutting off the fuel valve located on the fuel line.

Note: Also put Run/Stop switch in "Stop" position when engine is not running - battery will be discharged otherwise.

TABLE B.1

TYPICAL BIG RED™ 600 FUEL CONSUMPTION		
	Deutz F3L912 Engine 44HP (33Kw) @ 1800 RPM	Running Time for 75.7 L (20 Gal.)
High Idle - No Load 1890 R.P.M.	2.6 liters/hr (.69 gal/hr)	28.9 hrs
DC, CC Weld Output 500A/40V/100%	7.5 liters/hr (1.97 gal/hr)	10.1 hrs
DC, CC Weld Output 600A/30V/40%	4.4 liters/hr (1.16 gal/hr)	17.2 hrs
Auxiliary Power 3.6 Kw	3.0 liters/hr (.78 gal/hr)	25.5 hrs

NOTE: This data is for reference only. Fuel consumption is approximate and can be influenced by many factors, including engine maintenance, environmental conditions and fuel quality.

BIG RED™ 600

WELDER OPERATION

DUTY CYCLE

Duty Cycle is the percentage of time the load is being applied in a 10 minute period. For example a 60% duty cycle, represents 6 minutes of load and 4 minutes of no load in a 10 minute period.

ELECTRODE INFORMATION

The BIG RED™ 600 is designed for horizontal, vertical up, and overhead welding with all types of DC stick electrodes.

For any electrode the procedures should be kept within the rating of the machine. For information on electrodes and their proper application see (www.lincolnelectric.com) or the appropriate Lincoln publication.

WELDING MODE

Set the Welding mode switch for the desired process, either Stick / Gouging or TIG.

CONSTANT CURRENT STICK WELDING

⚠ CAUTION

DO NOT TURN THE “OUTPUT RANGE SELECTOR” WHILE WELDING because the current may arc between the contacts and damage the switch.

The “Output Range Selector” provides five overlapping current ranges. The “Output Current Adjustment” adjusts the current from minimum to maximum within each range. Open circuit voltage is also controlled by the “Output Current Adjustment” permitting control of the arc characteristics.

A high open circuit voltage setting provides the soft “buttering” arc with best resistance to pop-outs preferred for most welding. To get this characteristic, set the “Output Range Selector” to the lowest setting that still provides the current you need and set the “Output Current Adjustment” near maximum.

For example: to obtain 175 amps and a soft arc, set the “Output Range Selector” to the 105-220 position and then adjust the “Output Current Adjustment” to get 175 amps.

When a forceful “digging” arc is required, usually for vertical and overhead welding, use a higher “Output Range Selector” setting and lower open circuit voltage.

For example: to obtain 175 amps and a forceful arc, set the “Output Range Selector” to the 150-330 position and the “Output Current Adjustment” setting to get 175 amps.

Some arc instability may be experienced with EXX10 electrodes when trying to operate with long arc techniques at settings at the lower end of the open circuit voltage range.

⚠ CAUTION

DO NOT attempt to set the “Current Range Selector” between the five points designated on the nameplate.

ARC GOUGING

Using the “Output Range Selector” and “Output Control Adjustment” set the output to the desired level for the gouging electrode being used see table B.2.

TABLE B.2

Carbon Diameter	Current Range (DC, electrode positive)
1/8"(3.2mm)	60-90 Amps
5/32"(4.0mm)	90-150 Amps
3/16"(4.8mm)	200-250 Amps
1/4"(6.4mm)	300-400 Amps
5/16"(8.0mm)	350-450 Amps
3/8"(9.5mm)	450-600 Amps

BIG RED™ 600



TIG

The BIG RED™ 600 can be used for Scratch-Start of DC TIG welding applications.

Use the “Output Range Selector” and “Output Control Adjustments” to set the desired current. To initiate a weld, the tungsten electrode is then scratched on the work which establishes the arc. To stop the arc, simply lift the TIG torch away from the work piece. The tungsten may then be scratched on the work piece to restrike the arc.

If a high frequency start is desired, the K930-2 TIG Module can be used with the BIG RED™ 600. The BIG RED™ 600 and any high frequency generating equipment must be properly grounded. See the K930-2 TIG Module operating manuals for complete instructions on installation, operation, and maintenance.

When using the TIG Module, the OUTPUT control on the BIG RED™ 600 is used to set the maximum range of the CURRENT CONTROL on the TIG Module or an Amptrol if connected to the TIG Module.

TABLE B.3

TYPICAL CURRENT RANGES (1) FOR TUNGSTEN ELECTRODES(2)						
Tungsten Electrode Diameter in. (mm)	DCEN (-)	DCEP (+)	Approximate Argon Gas Flow Flow Rate C.F.H. (l /min.)		TIG TORCH Nozzle Size (4), (5)	
	1%, 2% Thoriated Tungsten	1%, 2% Thoriated Tungsten	Aluminum	Stainless Steel		
.010 (.25)	2-15	(3)	3-8 (2-4)	3-8 (2-4)	#4, #5, #6	
0.020 (.50)	5-20	(3)	5-10 (3-5)	5-10 (3-5)		
0.040 (1.0)	15-80	(3)	5-10 (3-5)	5-10 (3-5)		
1/16 (1.6)	70-150	10-20	5-10 (3-5)	9-13 (4-6)	#5, #6	
3/32 (2.4)	150-250	15-30	13-17 (6-8)	11-15 (5-7)	#6, #7, #8	
1/8 (3.2)	250-400	25-40	15-23 (7-11)	11-15 (5-7)		
5/32 (4.0)	400-500	40-55	21-25 (10-12)	13-17 (6-8)	#8, #10	
3/16 (4.8)	500-750	55-80	23-27 (11-13)	18-22 (8-10)		
1/4 (6.4)	750-1000	80-125	28-32 (13-15)	23-27 (11-13)		

(1) When used with argon gas. The current ranges shown must be reduced when using argon/helium or pure helium shielding gases.

(2) Tungsten electrodes are classified as follows by the American Welding Society (AWS):

Pure	EWP
1% Thoriated	EWTh-1
2% Thoriated	EWTh-2

Though not yet recognized by the AWS, Ceriated Tungsten is now widely accepted as a substitute for 2% Thoriated Tungsten in AC and DC applications.

(3) DCEP is not commonly used in these sizes.

(4) TIG torch nozzle "sizes" are in multiples of 1/16ths of an inch:

# 4 = 1/4 in.	(6 mm)
# 5 = 5/16 in.	(8 mm)
# 6 = 3/8 in.	(10 mm)
# 7 = 7/16 in.	(11 mm)
# 8 = 1/2 in.	(12.5 mm)
#10 = 5/8 in.	(16 mm)

(5) TIG torch nozzles are typically made from alumina ceramic. Special applications may require lava nozzles, which are less prone to breakage, but cannot withstand high temperatures and high duty cycles.

BIG RED™ 600



CONSTANT CURRENT OPERATION WITH A LINCOLN ELECTRIC WIRE FEEDER

Lincoln Electric does NOT recommend constant current semiautomatic welding for applications which need to meet specified weld metal chemical or mechanical property requirements or weld quality requirements.

Most semiautomatic welding processes perform better using constant voltage power sources. Welding codes usually do not address the power source selection or specifically, whether the welding process is to be operated in the constant voltage or constant current mode. Instead, codes typically specify limitations on the current, voltage, heat input and preheat temperature based on the material to be welded. The intention is to assure that proper weld material properties will develop. Welding is sometimes performed using constant current power sources. The operation can be more convenient because it may allow the use of an existing stick (SMAW) power source and the power source can be placed at a distant location without any provision for adjusting the output settings.

For constant current operation, the power source is set to deliver the specified current. The power source regulates this current regardless of changes in the welding circuit, including cable length, electrode diameter, wire feed speed, contact tip to work distance, etc.

Changes in the wire feed speed (WFS) or contact tip to work distance (CTWD) affect the arc voltage when constant current power sources are used. Lowering the wire feed speed raises the voltage, raising the wire feed speed lowers the voltage. Lengthening the contact tip to work distance raises the voltage, shortening the contact tip to work distance lowers the voltage. If the contact tip to work distance is properly maintained, a satisfactory operating voltage range may be achieved, and a sound weld may result. However, when a welder uses a longer contact tip to work distance, an arc-sensing wire feeder compensates by increasing the wire feed speed to regulate the voltage.

Even if the voltage and current remain unchanged, the increased wire feed speed may result in a deposition rate well beyond the specified range of the electrode. Under these conditions, the specified weld metal properties may not be achieved. Constant voltage power sources deliver large current surges to stabilize the arc when the electrode is shorted or the arc length is very short.

However, a constant current power source does not provide such a response to stabilize the arc. It may be difficult to achieve required weld metal properties, or to achieve the required quality of welds needed to pass nondestructive tests, when such welds are made under constant current operation.

AUXILIARY POWER:

The auxiliary power is independent of the welding power and thus not effected by the weld control settings.

Simultaneous Welding and Auxiliary Power Loads

The auxiliary power ratings are with no welding load. Simultaneous welding and power loads are specified in the following Table B.4.

TABLE B.4

BIG RED™ 600 Simultaneous Welding and Power Loads						
Weld Amps	PLUS	1 PHASE (120V)		OR	1 PHASE (240V)	
		WATTS	AMPS		WATTS	AMPS
0		2400	20		3600	15
100		2400	20		3600	15
200		2400	20		3600	15
300		2400	20		2400	10
400		1200	10		1200	5
500		0	0		0	0
600		0	0		0	0

TABLE B.5

BIG RED™ 600 Extension Cord Length Recommendations

(Use the shortest length extension cord possible sized per the following table.)

Current (Amps)	Voltage (Volts)	Load (Watts)	Maximum Allowable Cord Length in ft. (m) for Conductor Size											
			14 AWG		12 AWG		10 AWG		8 AWG		6 AWG		4 AWG	
15	120	1800	30	(9)	40	(12)	75	(23)	125	(38)	175	(53)	300	(91)
20	120	2400			30	(9)	50	(15)	88	(27)	138	(42)	225	(69)
15	240	3600	60	(18)	75	(23)	150	(46)	225	(69)	350	(107)	600	(183)

Conductor size is based on maximum 2.0% voltage drop.

BIG RED™ 600



OPTIONAL FEATURES

K2641-2 FOUR WHEELED STEERABLE YARD TRAILER

For in plant and yard towing. Comes standard with a Duo-Hitch™, a 2" Ball and Lunette Eye combination Hitch.

K2636-1 TRAILER - Two-wheeled trailer with optional fender and light package. For highway use, consult applicable federal, state, and local laws regarding possible additional requirements. Comes standard with a Duo-Hitch™, a 2" Ball and Lunette Eye combination hitch.

Order:

K2636-1 Trailer

K2639-1 Fender & Light Kit

K2640-1 Cable Storage Rack

K704 ACCESSORY SET - Includes 35 ft. (10m) of electrode cable and 30 ft. (9.1m) of work cable, head-shield, work clamp electrode holder. Cables are rated at 400 amps, 100% duty cycle.

K2861-1 REMOTE CONTROL - 100 ft. (30.4m)

Portable control provides same dial range as the output control on the welder. Has a convenient twist-lock plug for easy connection to the welder.

K2863-1 METER KIT

Easy-to-read analog meters for volts and amps. Easy to install.

K2864-1 SPARK ARRESTOR - Includes a heavy gage steel, approved spark arrestor, attaches to the muffler exhaust tube. Includes clamp.

SAFETY PRECAUTIONS

WARNING

Have qualified personnel do the maintenance work. Turn the engine off before working inside the machine. In some cases, it may be necessary to remove safety guards to perform required maintenance. Remove guards only when necessary and replace them when the maintenance requiring their removal is complete. Always use the greatest care when working near moving parts.

Do not put your hands near the engine cooling blower fan. If a problem cannot be corrected by following the instructions, take the machine to the nearest Lincoln Field Service Shop.



ELECTRIC SHOCK can kill.

- Do not touch electrically live parts or electrode with skin or wet clothing.
- Insulate yourself from work and ground
- Always wear dry insulating gloves.



ENGINE EXHAUST can kill.

- Use in open, well ventilated areas or vent exhaust outside.



MOVING PARTS can injure.

- Do not operate with doors open or guards off.
- Stop engine before servicing.
- Keep away from moving parts.

See additional warning information throughout this operator's manual and the Engine manual as well.

ROUTINE AND PERIODIC MAINTENANCE

DAILY

- Check the crankcase oil level .
- Refill the fuel tank to minimize moisture condensation in the tank.
- Open the water drain valve located on the bottom of the water separator element 1 or 2 turns and allow to drain into a container suitable for diesel fuel for 2 to 3 seconds. Repeat the above drainage procedure until diesel fuel is detected in the co

WEEKLY

Blow out the machine with low pressure air periodically. In particularly dirty locations, this may be required once a week.

ENGINE MAINTENANCE

Refer to the "Periodic Checks" section of the Engine Operator's Manual for the recommended maintenance schedule of the following:

- Engine Oil and Filter
- Air Cleaner
- Fuel Filter - and Delivery System
- Cooling Blower Belt
- Battery
- Cooling System

Refer to Table D.1 at the end of this section for various engine maintenance components.

ENGINE OIL CHANGE



Drain the engine oil while the engine is warm to assure rapid and complete draining. It is recommended that each time the oil is changed the oil filter be changed as well.

- Be sure the unit is off. Disconnect the negative battery cable to ensure safety.
- Locate oil drain hose and valve in bottom of base and pull through the hole in the case back or side of base on the welder.
- Remove the cap from the drain valve. Push valve in and twist counterclockwise. Pull to open and drain the oil into a suitable container for disposal.
- Close the drain valve by pushing in and twisting clockwise. Replace the cap.
- Re-fill the crankcase to the upper limit mark on the dipstick with the recommended oil (see engine operation manual OR engine service items decal OR below). Replace and tighten the oil filler cap securely.
- Push oil drain hose and valve back into unit, re-connect negative battery cable, and close doors and engine top cover before restarting unit. Wash your hands with soap and water after handling used motor oil. Please dispose of used motor oil in a manner that is compatible with the environment. We suggest you take it in a sealed container to your local service station or recycling center for reclamation. DO NOT throw it in the trash; pour it on the ground or down a drain.

Use motor oil designed for diesel engines that meets requirements for API service classification CC/CD/CE/CF/CF-4/CG-4 or CH-4.

ACEA E1/E2/E3. Always check the API service label on the oil container to be sure it includes the letters indicated. (Note: An S-grade oil must not be used in a diesel engine or damage may result. It IS permissible to use an oil that meets S and C grade service classifications.)

SAE 10W30 is recommended for general, all temperature use, 5F to 104F (-15C to 40C).

See engine owner's manual for more specific information on oil viscosity recommendations.

OIL FILTER CHANGE

- Drain the oil.
- Remove the oil filter with an oil filter wrench and drain the oil into a suitable container. Discard the used filter. Note: Care should be taken during filter removal to not disrupt or damage in any way the fuel lines.
- Clean the filter mounting base and coat the gasket of the new filter with clean engine oil.
- Screw the new filter on by hand until the gasket contacts the mounting base. Using an oil filter wrench, tighten the filter an additional 1/2 to 7/8 of a turn.
- Refill the crankcase with the specified amount of the recommended engine oil. Reinstall the oil filler cap and tighten securely.
- Start the engine and check for oil filter leaks.
- Stop the engine and check the oil level. If necessary, add oil to the upper limit mark on the dipstick.

AIR FILTER

CAUTION

EXCESSIVE AIR FILTER RESTRICTION WILL RESULT IN REDUCED ENGINE LIFE.

The air filter element is a dry cartridge type. It can be cleaned and reused; however, damaged elements should not be reused. Stop engine after 100 hours of running time and clean filter element, replace the filter if necessary. Service air cleaner regularly according to Engine Operator's Manual.

1. Locate the air filter canister located behind the engine door on the top of the engine.
2. Remove air filter element.

3. Remove loose dirt from element with compressed air or water hose directed from inside out.

Compressed Air: 100 psi maximum with nozzles at least one inch away from element.

Water Hose: 40 psi maximum without nozzle.

4. Soak element in a mild detergent solution for 15 minutes. Do not soak more than 24 hours. Swish element around in the solution to help remove dirt.
5. Rinse elements from inside out with a gentle stream of water (less than 40 psi) to remove all suds and dirt.
6. Dry element before reuse with warm air at less than 160°F (71°C). Do not use a light bulb to dry the element.
7. Inspect for holes and tears by looking through the element toward a bright light. Check for damaged gaskets or dented metal parts. Do not reuse damaged elements. Protect element from dust and damage during drying and storage.
8. Reinstall air filter element.

After six cleanings replace air filter. A cleaned filter will have approximately 70% of the life of a new filter element. A restricted filter element may not appear excessively dirty.

FUEL



At the end of each day's use, refill the fuel tank to minimize moisture condensation and dirt contamination in the fuel line. Do not overfill; leave room for the fuel to expand.

Use only fresh No. 2D diesel fuel, the use of No. 1D diesel fuel is recommended in place of No. 2D at temperatures below 23°F (-5°C). Do not use kerosene.

See the Engine Operator's Manual for instructions on replacing the fuel filter.

BLEEDING THE FUEL SYSTEM

You may need to bleed air from the fuel system if the fuel filter or fuel lines have been detached, the fuel tank has been ran empty or after periods of long storage. It is recommended that the fuel shutoff valve be closed during periods of non-use.

WARNING

To avoid personal injury, do not bleed a hot engine. This could cause fuel to spill onto a hot exhaust manifold, creating a danger of fire.

BIG RED™ 600



FUEL FILTERS

WARNING

When working on the fuel system



- Keep naked lights away, do not smoke !

- Do not spill fuel !

The BIG RED™ 600 is equipped with a **Fuel Pre-Filter/Water Separator Assembly** located before the lift pump and a **Secondary Fuel Filter** located after the lift pump and before the fuel injectors. The Fuel Pre-Filter/Water Separator is mounted to the engine block just below the lift pump. The Secondary Fuel Filter is mounted directly to the engine just above the oil filter.

FUEL PRE-FILTER/WATER SEPARATOR ASSEMBLY

The pre-filter is a 150 micron screen designed to protect against gross fuel contamination of the water separator element and the Secondary Fuel Filter. If the pre-filter becomes plugged it may be removed, inspected, cleaned and reinstalled. In general this only needs to be done with each water separator element change (about every 1,000 hrs.) However if at any time excessive fuel contamination is suspected or a sudden fall-off in engine performance is detected the pre-filter screen should be inspected and cleaned. Follow the following procedure:

1. Close the fuel shutoff valve (Lever should be perpendicular to the hose) located on the side of the Fuel Pre-Filter/Water Separator Assembly.
2. Unscrew the cap ring located on the top of the filter header and remove the plastic center cap and O-ring.
3. Remove the large white volume plug located directly under the center cap in the upper cavity of the filter header. Use a small screw driver (or similar device) to lift the plug part way out of the cavity to assist with its removal.

Be careful not to damage the pre-filter screen with the tool used to remove the plug.

4. Using a pair of pliers, gently tug on the pull tabs of the pre-filter screen in an alternating pattern to gradually remove the pre-filter screen.

5. Brush off any debris and rinse in diesel fuel.
6. Re-install the pre-filter screen into the upper cavity of the filter header making sure the four pull tabs are pointing up. Putting your fingers on the pull tabs, push down evenly until the lower body of the pre-filter screen contacts the floor of the upper cavity.
7. Re-insert the large white volume plug into the upper cavity.
8. Place the O-ring onto the angled seal surface of the filter header and re-install the plastic cap. Make sure its flange rests on the O-ring.
9. Screw on the cap ring and tighten hand tight.
10. Remember to open the fuel shutoff valve (Lever in line with the hose) before starting the engine.

WATER SEPARATOR ELEMENT

The water separator element is a two stage filter with a special filtration/water separating media, and an expanded water reservoir providing maximum protection against water in the fuel. The recommended change interval for the water separator element is 1,000 hours. The procedure for changing the element is as follows:

1. Close the fuel shutoff valve (Lever should be perpendicular to the hose) located on the side of the Fuel Pre-Filter/Water Separator Assembly.
2. Rotate the quick change ring (located just below filter header) clockwise approximately 1/2 turn and slide it down and off of the element.
3. Grasp the element and pull down with a slight rocking motion to remove the element from the grommet post on the bottom of the filter header.
4. Slide the new element onto the grommet post on the bottom of the filter header until the element no longer easily moves up into the filter header. Now rotate the element (may take almost 1 full turn) with a slight upward pressure until the element begins to further engage the header. With the proper orientation now established apply additional pressure to seat the element in the filter header. You should feel the element "pop" into place when properly seated.

Note: The element will only go on one way. Never use excessive force when mounting the element to the header.

BIG RED™ 600



5. Slide the quick change ring up over the element and rotate counter clockwise until an audible click or pop is heard. If you do not hear the click you have not rotated the ring far enough and the element is not in the locked position. Another indication that the ring is in the locked position is that one set (it doesn't matter which one) of arrows located on the outside of the ring should be located directly under the air vent valve.
6. Open the fuel shutoff valve (lever in line with the hose).
7. Open the air vent valve on the front of the filter header until fuel emerges free of air bubbles and then close the air vent valve.
Note: Consult your engine operation manual for information on air bleeding the entire fuel system.

SECONDARY FUEL FILTER

The Secondary Fuel Filter is a spin on cartridge type mount directly to the engine. Consult your engine operation manual for complete information on service intervals and element changing procedures.

COOLING SYSTEM

The cooling system of the Deutz engine needs to be checked and cleaned periodically. Consult the engine owners manual for the proper frequency and procedure.

COOLING BLOWER BELT

The following procedure should be followed to replace the cooling blower belt:

1. Allow the machine to cool.
2. Unfasten and slide the battery holder out from the welder.
3. Disconnect the negative battery cable.
4. Remove engine case side.
5. Loosen air cleaner hose clamp and detach hose.
6. Remove screws securing the engine end panel with air box and air cleaner attached to the base and roof. Pull this assembly away from roof and base. This will provide access for removing the belt from the blower pulley in step 8.
7. Loosen the alternator mounting bolts and rotate the alternator towards the engine.
8. Remove the old cooling blower belt and install a new one.
9. Adjust the cold belt tension to 63-73 lbs. midway between any two pulleys.
10. Reinstall the air cleaner hose, engine case side and end panel. Reattach the negative battery cable. Slide in and refasten the battery holder.
11. Check the cooling blower belt tension after 100 hours of operation. (Follow steps 1,2,3,4,,9 & 10)

BATTERY HANDLING

GASES FROM BATTERY can explode.



- Keep sparks, flame and cigarettes away from battery.

To prevent **EXPLOSION** when:



- **INSTALLING A NEW BATTERY** - disconnect negative cable from old battery first and connect to new battery last.

- **CONNECTING A BATTERY CHARGER** - Remove battery from welder by disconnecting negative cable first, then positive cable and battery clamp. When reinstalling, connect negative cable last. Keep well ventilated.



- **USING A BOOSTER** - connect positive lead to battery first then connect negative lead to engine foot.

BATTERY ACID CAN BURN EYES AND SKIN.

- Wear gloves and eye protection and be careful when working near battery. Follow instructions printed on battery.

PREVENTING ELECTRICAL DAMAGE

1. When replacing, jumping, or otherwise connecting the battery to the battery cables, the proper polarity must be observed. Failure to observe the proper polarity could result in damage to the charging circuit. The positive (+) battery cable has a red terminal cover.
2. If the battery requires charging from an external charger, disconnect the negative battery cable first and then the positive battery cable before attaching the charger leads. Failure to do so can result in damage to the internal charger components. When reconnecting the cables, connect the positive cable first and the negative cable last.

PREVENTING BATTERY DISCHARGE

Turn off the RUN/STOP to stop when engine is not running.

BIG RED™ 600



PREVENTING BATTERY BUCKLING

Tighten nuts on battery clamp until snug.

CHARGING THE BATTERY

When you charge, jump, replace, or otherwise connect battery cables to the battery, be sure the polarity is correct. Improper polarity can damage the charging circuit. The Vantage positive (+) battery terminal has a red terminal cover.

If you need to charge the battery with an external charger, disconnect the negative cable first, then the positive cable before you attach the charger leads. After the battery is charged, reconnect the positive battery cable first and the negative cable last. Failure to do so can result in damage to the internal charger components.

Follow the instructions of the battery charger manufacturer for proper charger settings and charging time.

SERVICING OPTIONAL SPARK ARRESTOR

Clean every 100 hours.

⚠ WARNING

- **MUFFLER MAY BE HOT**
- **ALLOW ENGINE TO COOL BEFORE INSTALLING THE SPARK ARRESTER!**
- **DO NOT OPERATE ENGINE WHILE INSTALLING THE SPARK ARRESTER!**

NAMEPLATES / WARNING DECALS MAINTENANCE

Whenever routine maintenance is performed on this machine - or at least yearly - inspect all nameplates and labels for legibility. Replace those which are no longer clear. Refer to the parts list for the replacement item number.

Table D.1 Engine Maintenance Components

ITEM	MAKE	PART NUMBER	SERVICE INTERVAL
Air Cleaner Element	DONALDSON FLEETGUARD	P822768 AF25436	CLEAN AS NEEDED REPLACE EVERY 200 HOURS
Cooling Blower Belt	DEUTZ GATES	223-5256 7580	SEE
Oil Filter Element	DEUTZ PUROLATOR NAPA FRAM	117-4418 PER2168 1820 PH3776	DEUTZ MAINTENANCE
Fuel Filter Element	DEUTZ PUROLATOR NAPA FRAM	117-4423 PC42 3358 P4102	DECAL
Water Separator Element	LINCOLN STANADYNE	M16890-C 31572	REPLACE EVERY 1000 HOURS
Fuel Pre-Filter Screen	LINCOLN STANADYNE	M16890-B 29575	INSPECT EVERY 1000 HOURS
Battery	-----	BCI Group 34	INSPECT EVERY 500 HOURS

BIG RED™ 600



WELDER / GENERATOR MAINTENANCE

STORAGE

Store the BIG RED™ 600 in clean, dry protected areas.

CLEANING

Blow out the generator and controls periodically with low pressure air. Do this at least once a week in particularly dirty areas.

BRUSH REMOVAL AND REPLACEMENT

It is normal for the brushes and slip rings to wear and darken slightly. Inspect the brushes when a generator overhaul is necessary.

WARNING

Do not attempt to polish slip rings while the engine is running.

GFCI MODULE TESTING AND RESETTING PROCEDURE

The GFCI module should be properly tested at least once every month or whenever it is tripped. To properly test and reset the GFCI module:

- If the module has tripped, first carefully remove any load and check it for damage.
- If the equipment has been shut down, it must be restarted.
- The equipment needs to be operating at high idle speed and any necessary adjustments made on the control panel so that the equipment is providing at least 80 volts to the receptacle input terminals.
- The circuit breaker for this receptacle must not be tripped. Reset if necessary.
- Push the "Reset" button located on the GFCI module. This will assure normal GFCI operation.
- Plug a night-light (with an "ON/OFF" switch) or other product (such as a lamp) into the Duplex receptacle and turn the product "ON".
- Push the "Test" button located on the GFCI module. The night-light or other product should go "OFF".
- Push the "Reset" button, again. The light or other product should go "ON" again.

If the light or other product remains "ON" when the "Test" button is pushed, the GFCI module is not working properly or has been incorrectly installed (mis-wired). If your GFCI module is not working properly, contact a qualified, certified electrician who can assess the situation, rewire the GFCI module if necessary or replace the device.

BIG RED™ 600



HOW TO USE TROUBLESHOOTING GUIDE

WARNING

Service and Repair should only be performed by Lincoln Electric Factory Trained Personnel. Unauthorized repairs performed on this equipment may result in danger to the technician and machine operator and will invalidate your factory warranty. For your safety and to avoid Electrical Shock, please observe all safety notes and precautions detailed throughout this manual.

This Troubleshooting Guide is provided to help you locate and repair possible machine malfunctions. Simply follow the three-step procedure listed below.

Step 1. LOCATE PROBLEM (SYMPTOM).

Look under the column labeled "PROBLEM (SYMPTOMS)". This column describes possible symptoms that the machine may exhibit. Find the listing that best describes the symptom that the machine is exhibiting.

Step 2. POSSIBLE CAUSE.

The second column labeled "POSSIBLE CAUSE" lists the obvious external possibilities that may contribute to the machine symptom.

Step 3. RECOMMENDED COURSE OF ACTION

This column provides a course of action for the Possible Cause, generally it states to contact your local Lincoln Authorized Field Service Facility.

If you do not understand or are unable to perform the Recommended Course of Action safely, contact your local Lincoln Authorized Field Service Facility.

CAUTION

If for any reason you do not understand the test procedures or are unable to perform the tests/repairs safely, contact your **Local Lincoln Authorized Field Service Facility** for technical troubleshooting assistance before you proceed.

Observe all Safety Guidelines detailed throughout this manual

PROBLEMS (SYMPTOMS)	POSSIBLE CAUSE	RECOMMENDED COURSE OF ACTION
Major Physical or Electrical Damage is Evident.	1. Contact your Local Lincoln Authorized Field Service Facility.	If all recommended possible areas of misadjustment have been checked and the problem persists, Contact your local Lincoln Authorized Field Service Facility.
Engine will not crank	<ol style="list-style-type: none"> 1. Battery low. 2. Loose battery cable connections which may need Inspected, cleaned or tighten. 3. Faulty wiring in engine starting circuit. 4. Faulty engine starter. Contact authorized local Engine Service Shop. 	
Engine will crank but not start.	<ol style="list-style-type: none"> 1. Out of fuel. 2. Fuel shut off valve is in the off position make sure the valve lever is in a vertical direction. 3. Engine shut down solenoid not pulling in. 4. On/Off switch on for more than 60 sec. before starting, the On/Off switch will need to be switch off and turned back on. Defective CR3. Replace CR3. 5. Fuel Filters dirty/clogged, gelled (Colder Climates), for gelled fuel, remove and replace filters. Run a diesel fuel treatment that dissolves the wax crystals until full power has been revolved. Main filter element and/or Inline Fuel Filter may need to be replaced. 6. High oil temperature or low oil pressure. (engine protection light lit) 	
Engine shuts down shortly after starting.	<ol style="list-style-type: none"> 1. Low oil pressure (engine protection light lit). Check oil level (Consult engine service dealer). 2. High oil temperature. (engine protection light lit). 3. Faulty oil pressure switch. 4. Faulty oil temperature switch. Contact authorized local Engine Service Shop. 5. Low output of battery charging alternator (battery charging light lit). 	

 **CAUTION**

If for any reason you do not understand the test procedures or are unable to perform the tests/repairs safely, contact your **Local Lincoln Authorized Field Service Facility** for technical troubleshooting assistance before you proceed.

BIG RED™ 600



Observe all Safety Guidelines detailed throughout this manual

PROBLEMS (SYMPTOMS)	POSSIBLE CAUSE	RECOMMENDED COURSE OF ACTION
Engine shuts down while under a load.	1. High oil temperature.	If all recommended possible areas of misadjustment have been checked and the problem persists, Contact your local Lincoln Authorized Field Service Facility.
Engine runs rough.	1. Dirty fuel or air filters may need cleaned/replaced. 2. Water in fuel. 3. Fuel injector clogged or malfunctioning.	
Engine will not shut off	1. Fuel Shutdown solenoid not functioning properly / linkage binding.	
Battery does not stay charged.	1. Faulty battery . 2. Faulty engine alternator. 3. Loose or broken lead in charging circuit. 4. Loose fan belt may need tightening.	
No welding output.	1. Broken lead in weld rotor circuits. 2. Faulty field diode module. 3. Faulty weld rotor. 4. Open Breaker. 5. Check that selector switch is in position.	
Welder has some/ no output and no control. Auxiliary output OK	1. Faulty remote kit. 2. Faulty output control Rheostat. 3. Faulty output control wiring.	
No auxiliary power.	1. Open breakers. 2. Faulty receptacle. 3. Faulty auxiliary circuit wiring. 4. GFCI Module tripped. (See Maintenance Section) 5. Broken Lead in Auxiliary rotor circuit. 6. Faulty Auxiliary Rotor field Diode module. 7. Faulty weld rotor.	

 **CAUTION**

If for any reason you do not understand the test procedures or are unable to perform the tests/repairs safely, contact your **Local Lincoln Authorized Field Service Facility** for technical troubleshooting assistance before you proceed.

BIG RED™ 600



INSTRUCTIONS FOR INSTALLING A 2-POLE RESIDUAL CURRENT DEVICE TO PROTECT THE 240V SINGLE PHASE RECEPTACLE

WARNING	<ul style="list-style-type: none">• Do not operate with covers removed• Disconnect input power before servicing• Do not touch electrically live parts• Only qualified persons should install, use or service this equipment
	
ELECTRIC SHOCK CAN KILL	

1. TURN OFF THE ENGINE AND DISCONNECT THE NEGATIVE BATTERY CABLE.
2. REMOVE THE SCREWS THAT SECURE THE LOWER CONTROL PANEL AND OPEN THE PANEL.
3. WHILE HOLDING THE RCD MOUNTING BRACKET REMOVE THE TWO SCREWS SECURING THE COVER PLATE AND RCD MOUNTING BRACKET. SET THE RCD MOUNTING BRACKET AND SCREWS ASIDE AND DISCARD COVER PLATE. (SEE FIGURE 1).

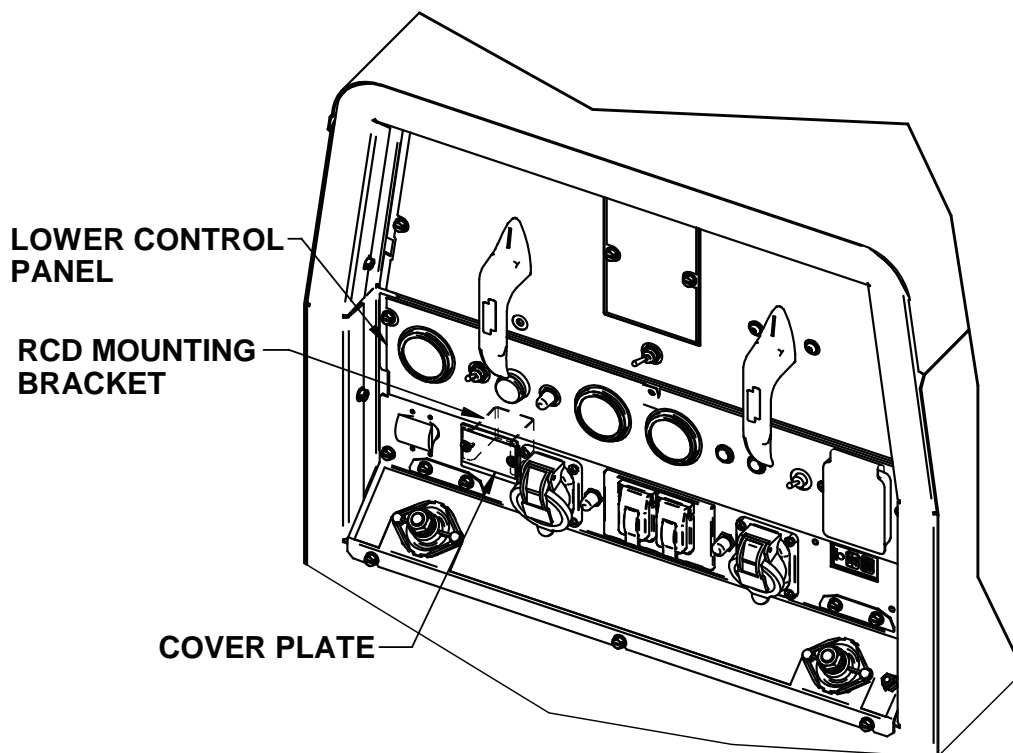

FIGURE 1

A

M22253

BIG RED™ 600



4. LOCATE LEADS 3D & 6J. (SEE FIGURE 2). CUT BOTH LEADS AS SHOWN.
5. STRIP ALL FOUR LEADS 13MM (.50 in.)

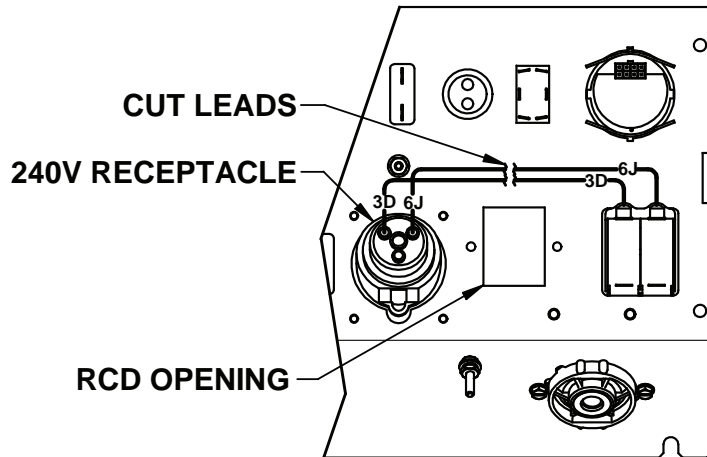

FIGURE 2

6. CONNECT LEADS FROM CIRCUIT BREAKER & RECEPTACLE TO RCD AS SHOWN & TIGHTEN LEADS TO 2.4NM (21 in-lb). (SEE FIGURE 3). NOTE LEAD CONFIGURATION. COAT AREA WHERE LEADS CONNECT TO RCD WITH A SILICONE RUBBER RTV SEALANT.
7. MOUNT RCD & PROTECTIVE BOOT TO PANEL USING MOUNTING BRACKET & SCREWS SET ASIDE IN STEP 3.

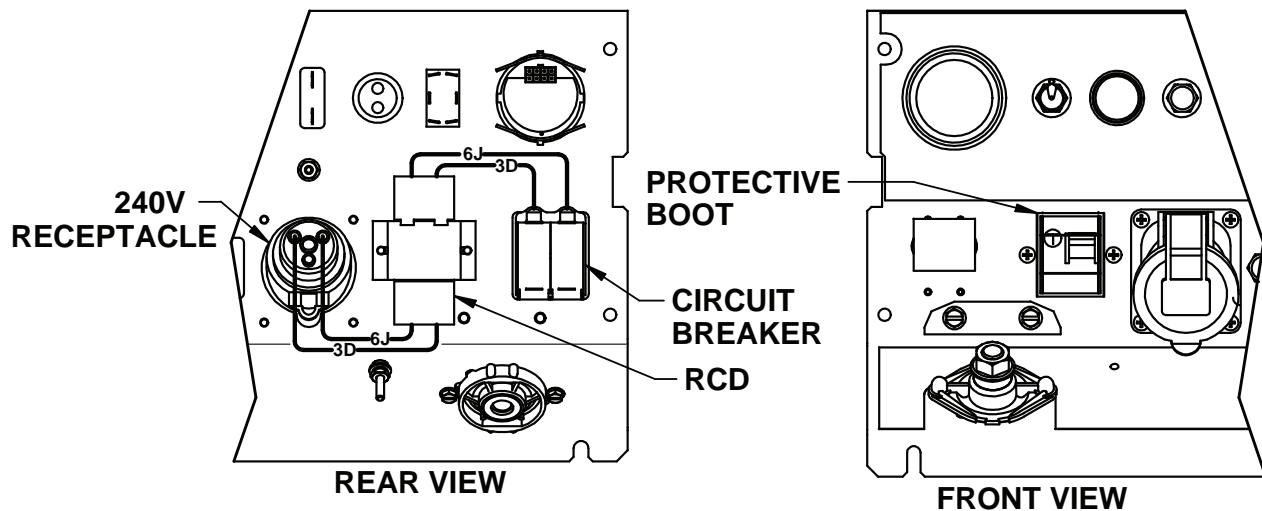

FIGURE 3

8. SECURE LOWER CONTROL PANEL IN PLACE.
9. RECONNECT NEGATIVE BATTERY CABLE.

THE UNIT IS NOW READY FOR OPERATION

A

M22253

BIG RED™ 600

BIG RED 600 (K2811-1) WIRING DIAGRAM

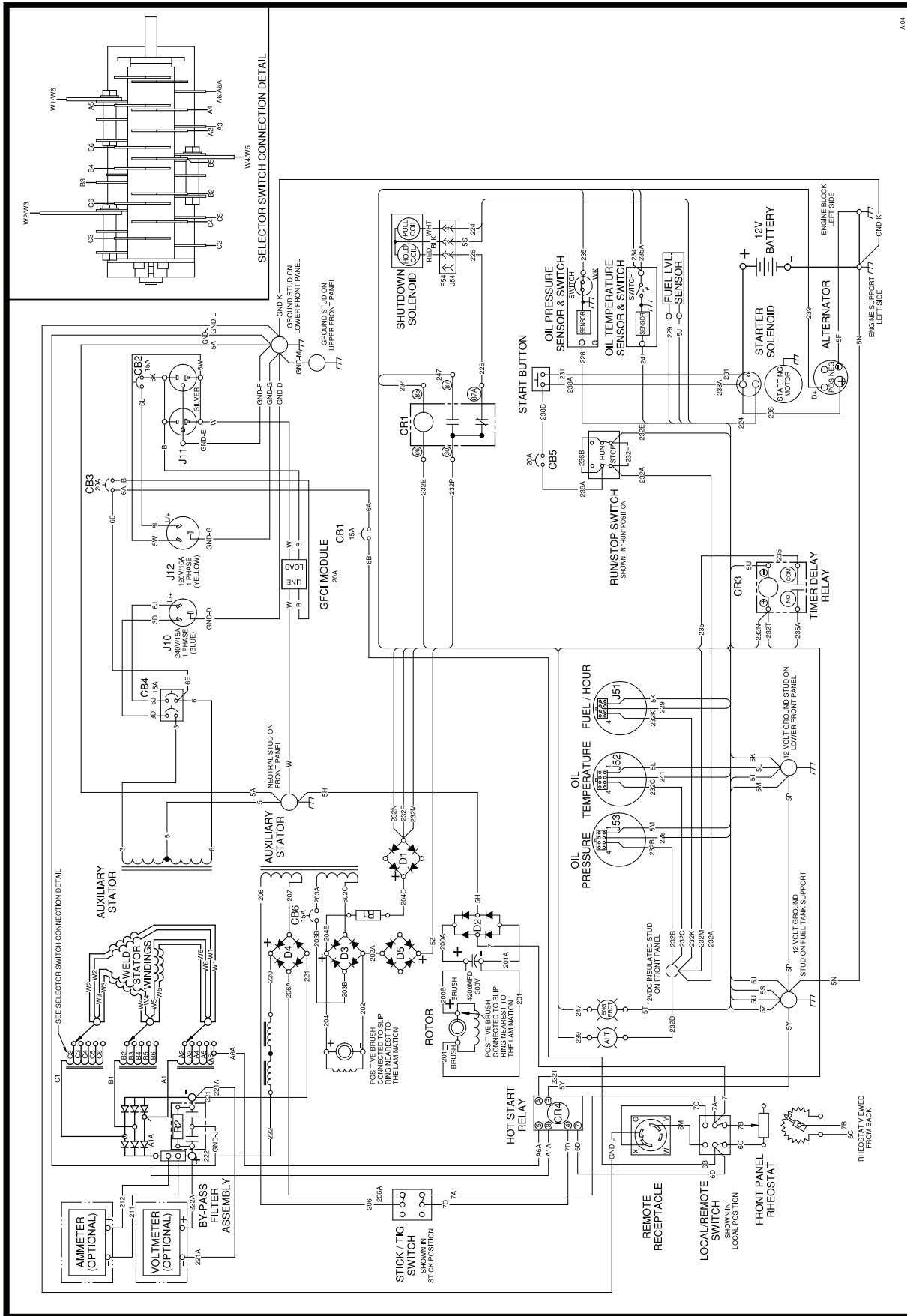

G6574

NOTE: This diagram is for reference only. It may not be accurate for all machines covered by this manual. The specific diagram for a particular code is pasted inside the machine on one of the enclosure panels. If the diagram is illegible, write to the Service Department for a replacement. Give the equipment code number.

BIG RED™ 600



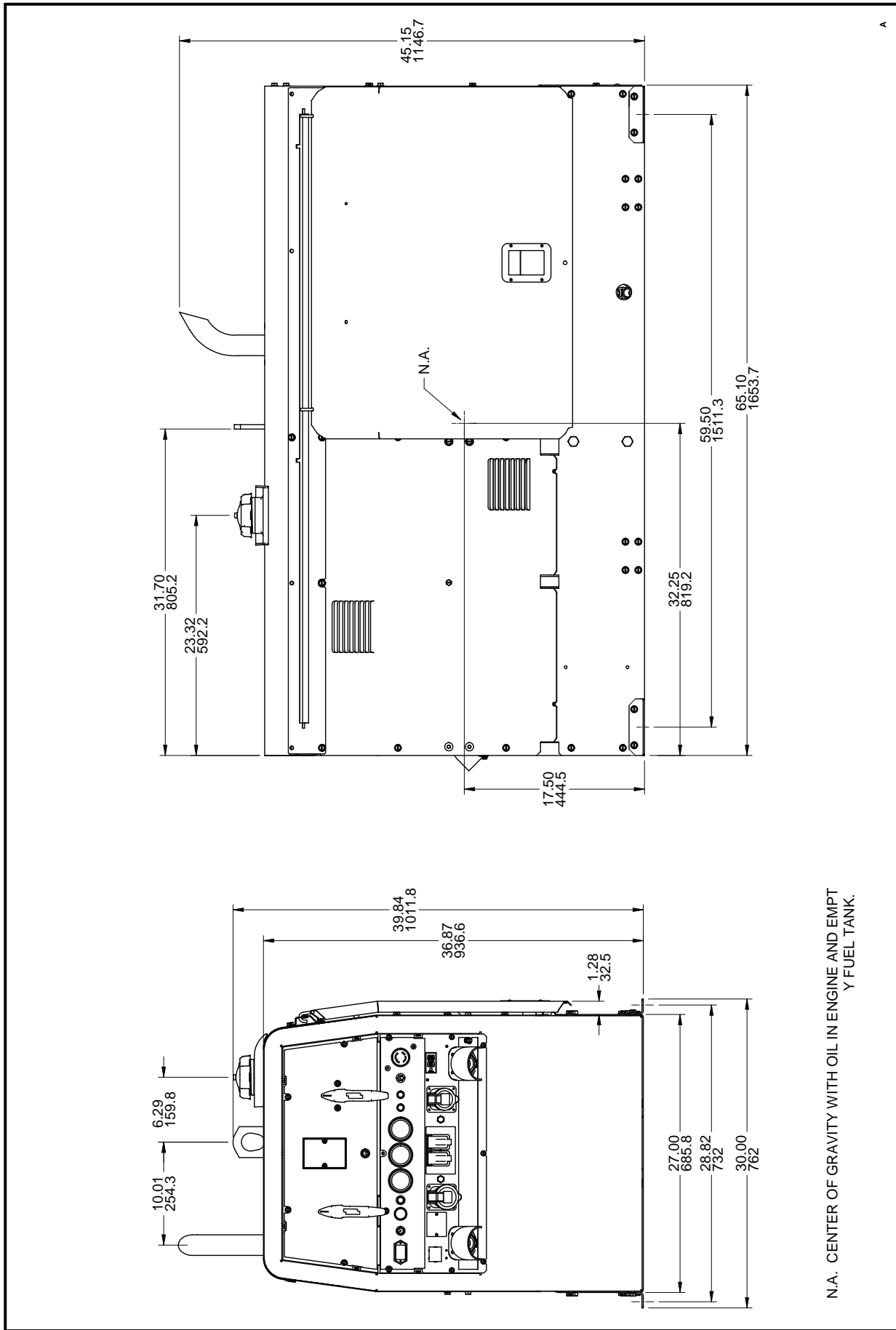

M22223

N.A. CENTER OF GRAVITY WITH OIL IN ENGINE AND EMPTY FUEL TANK.

NOTE: This diagram is for reference only. It may not be accurate for all machines covered by this manual. The specific diagram for a particular code is pasted inside the machine on one of the enclosure panels. If the diagram is illegible, write to the Service Department for a replacement. Give the equipment code number.

BIG RED™ 600



NOTES

BIG RED™ 600



			
WARNING	<ul style="list-style-type: none"> Do not touch electrically live parts or electrode with skin or wet clothing. Insulate yourself from work and ground. 	<ul style="list-style-type: none"> Keep flammable materials away. 	<ul style="list-style-type: none"> Wear eye, ear and body protection.
Spanish AVISO DE PRECAUCION	<ul style="list-style-type: none"> No toque las partes o los electrodos bajo carga con la piel o ropa mojada. Aíslese del trabajo y de la tierra. 	<ul style="list-style-type: none"> Mantenga el material combustible fuera del área de trabajo. 	<ul style="list-style-type: none"> Protéjase los ojos, los oídos y el cuerpo.
French ATTENTION	<ul style="list-style-type: none"> Ne laissez ni la peau ni des vêtements mouillés entrer en contact avec des pièces sous tension. Isolez-vous du travail et de la terre. 	<ul style="list-style-type: none"> Gardez à l'écart de tout matériel inflammable. 	<ul style="list-style-type: none"> Protégez vos yeux, vos oreilles et votre corps.
German WARNUNG	<ul style="list-style-type: none"> Berühren Sie keine stromführenden Teile oder Elektroden mit Ihrem Körper oder feuchter Kleidung! Isolieren Sie sich von den Elektroden und dem Erdboden! 	<ul style="list-style-type: none"> Entfernen Sie brennbares Material! 	<ul style="list-style-type: none"> Tragen Sie Augen-, Ohren- und Körperschutz!
Portuguese ATENÇÃO	<ul style="list-style-type: none"> Não toque partes elétricas e electrodos com a pele ou roupa molhada. Isole-se da peça e terra. 	<ul style="list-style-type: none"> Mantenha inflamáveis bem guardados. 	<ul style="list-style-type: none"> Use proteção para a vista, ouvido e corpo.
Japanese 注意事項	<ul style="list-style-type: none"> ● 通電中の電気部品、又は溶材にヒブやぬれた布で触れないこと。 ● 施工物やアースから身体が絶縁されている様にして下さい。 	<ul style="list-style-type: none"> ● 燃えやすいものの側での溶接作業は絶対にしてはなりません。 	<ul style="list-style-type: none"> ● 目、耳及び身体に保護具をして下さい。
Chinese 警告	<ul style="list-style-type: none"> ● 皮肤或湿衣物切勿接触带电部件及焊缝。 ● 使你自己与地面和工件绝缘。 	<ul style="list-style-type: none"> ● 把一切易燃物品移离工作场所。 	<ul style="list-style-type: none"> ● 佩戴眼、耳及身体劳动保护用具。
Korean 위험	<ul style="list-style-type: none"> ● 전도체나 용접봉을 젖은 헝겍 또는 피부로 절대 접촉치 마십시오. ● 모재와 접지를 접촉치 마십시오. 	<ul style="list-style-type: none"> ● 인화성 물질을 접근시키지 마십시오. 	<ul style="list-style-type: none"> ● 눈, 귀와 몸에 보호장구를 착용하십시오.
Arabic تحذير	<ul style="list-style-type: none"> ● لا تلمس الاجزاء التي يسري فيها التيار الكهربائي أو الألكترود بجلك الجسم أو بالملابس المبللة بالماء. ● ضع عازلا على جسمك خلال العمل. 	<ul style="list-style-type: none"> ● ضع المواد القابلة للاشتعال في مكان بعيد. 	<ul style="list-style-type: none"> ● ضع أدوات وملابس واقية على عينيك وأذنيك وجسمك.

READ AND UNDERSTAND THE MANUFACTURER'S INSTRUCTION FOR THIS EQUIPMENT AND THE CONSUMABLES TO BE USED AND FOLLOW YOUR EMPLOYER'S SAFETY PRACTICES.

SE RECOMIENDA LEER Y ENTENDER LAS INSTRUCCIONES DEL FABRICANTE PARA EL USO DE ESTE EQUIPO Y LOS CONSUMIBLES QUE VA A UTILIZAR, SIGA LAS MEDIDAS DE SEGURIDAD DE SU SUPERVISOR.

LISEZ ET COMPRENEZ LES INSTRUCTIONS DU FABRICANT EN CE QUI REGARDE CET EQUIPMENT ET LES PRODUITS A ETRE EMPLOYES ET SUIVEZ LES PROCEDURES DE SECURITE DE VOTRE EMPLOYEUR.

LESEN SIE UND BEFOLGEN SIE DIE BETRIEBSANLEITUNG DER ANLAGE UND DEN ELEKTRODENEINSATZ DES HERSTELLERS. DIE UNFALLVERHÜTUNGSVORSCHRIFTEN DES ARBEITGEBERS SIND EBENFALLS ZU BEACHTEN.

			
<ul style="list-style-type: none"> • Keep your head out of fumes. • Use ventilation or exhaust to remove fumes from breathing zone. 	<ul style="list-style-type: none"> • Turn power off before servicing. 	<ul style="list-style-type: none"> • Do not operate with panel open or guards off. 	WARNING
<ul style="list-style-type: none"> • Los humos fuera de la zona de respiración. • Mantenga la cabeza fuera de los humos. Utilice ventilación o aspiración para gases. 	<ul style="list-style-type: none"> • Desconectar el cable de alimentación de poder de la máquina antes de iniciar cualquier servicio. 	<ul style="list-style-type: none"> • No operar con panel abierto o guardas quitadas. 	Spanish AVISO DE PRECAUCION
<ul style="list-style-type: none"> • Gardez la tête à l'écart des fumées. • Utilisez un ventilateur ou un aspirateur pour ôter les fumées des zones de travail. 	<ul style="list-style-type: none"> • Débranchez le courant avant l'entretien. 	<ul style="list-style-type: none"> • N'opérez pas avec les panneaux ouverts ou avec les dispositifs de protection enlevés. 	French ATTENTION
<ul style="list-style-type: none"> • Vermeiden Sie das Einatmen von Schweißrauch! • Sorgen Sie für gute Be- und Entlüftung des Arbeitsplatzes! 	<ul style="list-style-type: none"> • Strom vor Wartungsarbeiten abschalten! (Netzstrom völlig öffnen; Maschine anhalten!) 	<ul style="list-style-type: none"> • Anlage nie ohne Schutzgehäuse oder Innenschutzverkleidung in Betrieb setzen! 	German WARNUNG
<ul style="list-style-type: none"> • Mantenha seu rosto da fumaça. • Use ventilação e exaustão para remover fumo da zona respiratória. 	<ul style="list-style-type: none"> • Não opere com as tampas removidas. • Desligue a corrente antes de fazer serviço. • Não toque as partes elétricas nuas. 	<ul style="list-style-type: none"> • Mantenha-se afastado das partes moventes. • Não opere com os painéis abertos ou guardas removidas. 	Portuguese ATENÇÃO
<ul style="list-style-type: none"> ● ヒュームから頭を離すようにして下さい。 ● 換気や排煙に十分留意して下さい。 	<ul style="list-style-type: none"> ● メンテナンス・サービスに取りかかる際には、まず電源スイッチを必ず切して下さい。 	<ul style="list-style-type: none"> ● パネルやカバーを取り外したまま機械操作をしないで下さい。 	Japanese 注意事項
<ul style="list-style-type: none"> ● 頭部遠離煙霧。 ● 在呼吸區使用通風或排風器除煙。 	<ul style="list-style-type: none"> ● 維修前切斷電源。 	<ul style="list-style-type: none"> ● 儀表板打開或沒有安全罩時不準作業。 	Chinese 警告
<ul style="list-style-type: none"> ● 얼굴로부터 용접가스를 멀리하십시오. ● 호흡지역으로부터 용접가스를 제거하기 위해 가스제거기나 통풍기를 사용하십시오. 	<ul style="list-style-type: none"> ● 보수전에 전원을 차단하십시오. 	<ul style="list-style-type: none"> ● 판넬이 열린 상태로 작동치 마십시오. 	Korean 위험
<ul style="list-style-type: none"> ● ابعء رأسك بعيداً عن الدخان. ● استعمل التهوية أو جهاز ضغط الدخان للخارج لكي تبعد الدخان عن المنطقة التي تتنفس فيها. 	<ul style="list-style-type: none"> ● اقطع التيار الكهربائي قبل القيام بأية صيانة. 	<ul style="list-style-type: none"> ● لا تشغيل هذا الجهاز اذا كانت الاغطية الحديدية الواقية ليست عليه. 	Arabic تحذير

LEIA E COMPREENDA AS INSTRUÇÕES DO FABRICANTE PARA ESTE EQUIPAMENTO E AS PARTES DE USO, E SIGA AS PRÁTICAS DE SEGURANÇA DO EMPREGADOR.

使う機械や溶材のメーカーの指示書をよく読み、まず理解して下さい。そして貴社の安全規定に従って下さい。

請詳細閱讀並理解製造廠提供的說明以及應該使用的銀焊材料，並請遵守貴方的有閣勞動保護規定。

이 제품에 동봉된 작업지침서를 숙지하시고 귀사의 작업자 안전수칙을 준수하시기 바랍니다.

اقرأ بتعمن وأفهم تعليمات المصنع المنتج لهذه المعدات والمواد قبل استعمالها واتبع تعليمات الوقاية لصاحب العمل.



• World's Leader in Welding and Cutting Products •

• Sales and Service through Subsidiaries and Distributors Worldwide •

Cleveland, Ohio 44117-1199 U.S.A. TEL: 216.481.8100 FAX: 216.486.1751 WEB SITE: www.lincolnelectric.com

Download from Www.Somanuals.com. All Manuals Search And Download.

Free Manuals Download Website

<http://myh66.com>

<http://usermanuals.us>

<http://www.somanuals.com>

<http://www.4manuals.cc>

<http://www.manual-lib.com>

<http://www.404manual.com>

<http://www.luxmanual.com>

<http://aubethermostatmanual.com>

Golf course search by state

<http://golfingnear.com>

Email search by domain

<http://emailbydomain.com>

Auto manuals search

<http://auto.somanuals.com>

TV manuals search

<http://tv.somanuals.com>