

SQUARE WAVE TIG 355

For use with machines having Code Numbers: 9951
9952
9953
9954
9955

Safety Depends on You

Lincoln arc welding and cutting equipment is designed and built with safety in mind. However, your overall safety can be increased by proper installation . . . and thoughtful operation on your part. **DO NOT INSTALL, OPERATE OR REPAIR THIS EQUIPMENT WITHOUT READING THIS MANUAL AND THE SAFETY PRECAUTIONS CONTAINED THROUGHOUT.** And, most importantly, think before you act and be careful.

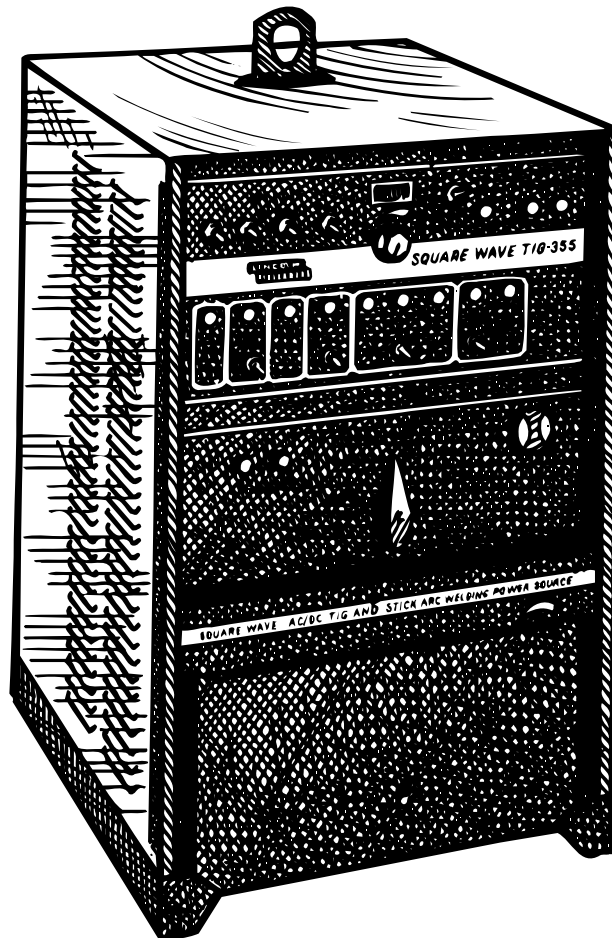

SERVICE MANUAL



World's Leader in Welding and Cutting Products

Premier Manufacturer of Industrial Motors

Sales and Service through subsidiaries and Distributors Worldwide
22801 St. Clair Ave. Cleveland, Ohio 44117-1199 U.S.A. Tel. (216) 481-8100

⚠ WARNING

ARC WELDING can be hazardous.

PROTECT YOURSELF AND OTHERS FROM POSSIBLE SERIOUS INJURY OR DEATH. KEEP CHILDREN AWAY. PACEMAKER WEARERS SHOULD CONSULT WITH THEIR DOCTOR BEFORE OPERATING.

Read and understand the following safety highlights. For additional safety information, it is strongly recommended that you purchase a copy of "Safety in Welding & Cutting - ANSI Standard Z49.1" from the American Welding Society, P.O. Box 351040, Miami, Florida 33135 or CSA Standard W117.2-1974. A Free copy of "Arc Welding Safety" booklet E205 is available from the Lincoln Electric Company, 22801 St. Clair Avenue, Cleveland, Ohio 44117-1199.

BE SURE THAT ALL INSTALLATION, OPERATION, MAINTENANCE AND REPAIR PROCEDURES ARE PERFORMED ONLY BY QUALIFIED INDIVIDUALS.

ELECTRIC SHOCK can kill.

1.a. The electrode and work (or ground) circuits are electrically "hot" when the welder is on. Do not touch these "hot" parts with your bare skin or wet clothing. Wear dry, hole-free gloves to insulate hands.

1.b. Insulate yourself from work and ground using dry insulation. Make certain the insulation is large enough to cover your full area of physical contact with work and ground.

In addition to the normal safety precautions, if welding must be performed under electrically hazardous conditions (in damp locations or while wearing wet clothing; on metal structures such as floors, gratings or scaffolds; when in cramped positions such as sitting, kneeling or lying, if there is a high risk of unavoidable or accidental contact with the workpiece or ground) use the following equipment:

- Semiautomatic DC Constant Voltage (Wire Welder).
- DC Manual (Stick) Welder.
- AC Welder with Reduce Voltage Control.

1.c. In semiautomatic or automatic wire welding, the electrode, electrode reel, welding head, nozzle or semiautomatic welding gun are also electrically "hot".

1.d. Always be sure the work cable makes a good electrical connection with the metal being welded. The connection should be as close as possible to the area being welded.

1.e. Ground the work or metal to be welded to a good electrical (earth) ground.

1.f. Maintain the electrode holder, work clamp, welding cable and welding machine in good, safe operating condition. Replace damaged insulation.

1.g. Never dip the electrode in water for cooling.

1.h. Never simultaneously touch electrically "hot" parts of electrode holders connected to two welders because voltage between the two can be the total of the open circuit voltage of both welders.

1.i. When working above floor level, use a safety belt to protect yourself from a fall should you get a shock.

1.j. Also see items 4.c. and 6.

ARC RAYS can burn.

2.a. Use a shield with the proper filter and cover plates to protect your eyes from sparks and the rays of the arc when welding or observing open arc welding. Headshield and filter lens should conform to ANSI Z87.1 standards.

2.b. Use suitable clothing made from durable flame-resistant material to protect your skin and that of your helpers from the arc rays.

2.c. Protect other nearby personnel with suitable, non-flammable screening and/or warn them not to watch the arc nor expose themselves to the arc rays or to hot spatter or metal.

FUMES AND GASES can be dangerous.

3.a. Welding may produce flames and gases hazardous to health. Avoid breathing these fumes and gases.

When welding, keep your head

out of the fume. Use enough ventilation and/or exhaust at the arc to keep fumes and gases away from the breathing zone. When welding with electrodes which require special ventilation such as stainless or hard facing (see instructions on container or MSDS) or on lead or cadmium plated steel and other metals or coatings which produce highly toxic fumes, keep exposure as low as possible and below Threshold Limit Values (TLV) using local exhaust or mechanical ventilation. In confined spaces or in some circumstances, outdoors, a respirator may be required. Additional precautions are also required when welding on galvanized steel.

3.b. Do not weld in locations near chlorinated hydrocarbon vapors coming from degreasing, cleaning or spraying operations. The heat and rays of the arc can react with solvent vapors to form phosgene, a highly toxic gas, and other irritating products.

3.c. Shielding gases used for arc welding can displace air and cause injury or death. Always use enough ventilation, especially in confined areas, to insure breathing air is safe.

3.d. Read and understand the manufacturer's instructions for this equipment and the consumables to be used, including the material safety data sheet (MSDS) and follow your employer's safety practices. MSDS forms are available from your welding distributor or from the manufacturer.

3.e. Also see item 7b.

SQUARE WAVE TIG 355





WELDING SPARKS can cause fire or explosion.

- 4.a. Remove fire hazards from the welding area. If this is not possible, cover them to prevent the welding sparks from starting a fire. Remember that welding

sparks and hot materials from welding can easily go through small cracks and openings to adjacent areas. Avoid welding near hydraulic lines. Have a fire extinguisher readily available.

- 4.b. Where compressed gases are to be used at the job site, special precautions should be used to prevent hazardous situations. Refer to "Safety in Welding and Cutting" (ANSI Standard Z49.1) and the operating information for the equipment being used.

- 4.c. When not welding, make certain no part of the electrode circuit is touching the work or ground. Accidental contact can cause overheating and create a fire hazard.

- 4.d. Do not heat, cut or weld tanks, drums or containers until the proper steps have been taken to insure that such procedures will not cause flammable or toxic vapors from substances inside. They can cause an explosion even though they have been "cleaned". For information, purchase "Recommended Safe Practices for the Preparation for Welding and Cutting of Containers and Piping That Have Held Hazardous Substances," AWS F4.1 from the American Welding Society (see address above).

- 4.e. Vent hollow castings or containers before heating, cutting or welding. They may explode.

- 4.f. Sparks and spatter are thrown from the welding arc. Wear oil free protective garments such as leather gloves, heavy shirt, cuffless trousers, high shoes and a cap over your hair. Wear ear plugs when welding out of position or in confined places. Always wear safety glasses with side shields when in a welding area.

- 4.g. Connect the work cable to the work as close to the welding area as practical. Work cables connected to the building framework or other locations away from the welding area increase the possibility of the welding current passing through lifting chains, crane cables or other alternate circuits. This can create fire hazards or overheat lifting chains or cables until they fail.

- 4.h. Also see item 7c.



CYLINDER may explode if damaged.

- 5.a. Use only compressed gas cylinders containing the correct shielding gas for the process used and properly operating regulators designed for the gas and

pressure used. All hoses, fittings, etc. should be suitable for the application and maintained in good condition.

- 5.b. Always keep cylinders in an upright position securely chained to an undercarriage or fixed support.

- 5.c. Cylinders should be located:
- Away from areas where they may be struck or subjected to physical damage.
 - A safe distance from arc welding or cutting operations and any other source of heat, sparks, or flame.

- 5.d. Never allow the electrode, electrode holder or any other electrically "hot" parts to touch a cylinder.

- 5.e. Keep your head and face away from the cylinder valve outlet when opening the cylinder valve.

- 5.f. Valve protection caps should always be in place and hand tight except when the cylinder is in use or connected for use.

- 5.g. Read and follow the instructions on compressed gas cylinders, associated equipment, and CGA publication P-1, "Precautions for Safe Handling of Compressed Gases in Cylinders," available from the Compressed Gas Association 1235 Jefferson Davis Highway, Arlington, VA 22202.



FOR ELECTRICALLY powered equipment.

- 6.a. Turn off input power using the disconnect switch at the fuse box before working on the equipment.

- 6.b. Install equipment in accordance with the U.S. National Electrical Code, all local codes and the manufacturer's recommendations.

- 6.c. Ground the equipment in accordance with the U.S. National Electrical Code and the manufacturer's recommendations.



FOR ENGINE powered equipment.

- 7.a. Turn the engine off before troubleshooting and maintenance work unless the maintenance work requires it to be running.



- 7.b. Operate engines in open, well-ventilated areas or vent the engine exhaust fumes outdoors.



- 7.c. Do not add the fuel near an open flame welding arc or when the engine is running. Stop the engine and allow it to cool before refueling to prevent spilled fuel from vaporizing on contact with hot engine parts and igniting. Do not spill fuel when filling tank. If fuel is spilled, wipe it up and do not start engine until fumes have been eliminated.



- 7.d. Keep all equipment safety guards, covers and devices in position and in good repair. Keep hands, air, clothing and tools away from V-belts, gears, fans and all other moving parts when starting, operating, or repairing equipment.

- 7.e. In some cases it may be necessary to remove safety guards to perform required maintenance. Remove guards only when necessary and replace them when the maintenance requiring their removal is complete. Always use the greatest care when working near moving parts.

- 7.f. Do not put your hands near the engine fan. Do not attempt to override the governor or idler by pushing on the throttle control rods while the engine is running.

- 7.g. To prevent accidentally starting gasoline engines while turning the engine or welding generator during maintenance work, disconnect the spark plug wires, distributor cap or magneto wire as appropriate.



- 7.h. To avoid scalding, do not remove the radiator pressure cap when the engine is hot.



ELECTRIC AND MAGNETIC FIELDS may be dangerous

- 8.a. Electric current flowing through any conductor causes localized Electric and Magnetic Fields (EMF). Welding current creates EMF fields around welding cables and welding machines.
- 8.b. EMF fields may interfere with some pacemakers, and welders have a pacemaker should consult their physician before welding.
- 8.c. Exposure to EMF fields in welding may have other health effects which are now not known.
- 8.d. All welders should use the following procedures in order to minimize exposure to EMF fields from the welding circuit:
- 8.d.1. Route the electrode and work cables together - Secure them with tape when possible.
 - 8.d.2. Never coil the electrode lead around your body.
 - 8.d.3. Do not place your body between the electrode and work cables. If the electrode cable is on your right side, the work cable should also be on your right side.
 - 8.d.4. Connect the work cable to the workpiece as close as possible to the area being welded.
 - 8.d.5. Do not work next to welding power source.

PRÉCAUTIONS DE SÛRETÉ

Pour votre propre protection lire et observer toutes les instructions et les précautions de sûreté spécifiques qui paraissent dans ce manuel aussi bien que les précautions de sûreté générales suivantes:

Sûreté Pour Soudage A L'Arc

1. Protégez-vous contre la secousse électrique:
 - a. Les circuits à l'électrode et à la pièce sont sous tension quand la machine à souder est en marche. Éviter toujours tout contact entre les parties sous tension et la peau nue ou les vêtements mouillés. Porter des gants secs et sans trous pour isoler les mains.
 - b. Faire très attention de bien s'isoler de la masse quand on soude dans des endroits humides, ou sur un plancher métallique ou des grilles métalliques, principalement dans les positions assis ou couché pour lesquelles une grande partie du corps peut être en contact avec la masse.
 - c. Maintenir le porte-électrode, la pince de masse, le câble de soudage et la machine à souder en bon et sûr état de fonctionnement.
 - d. Ne jamais plonger le porte-électrode dans l'eau pour le refroidir.
 - e. Ne jamais toucher simultanément les parties sous tension des porte-électrodes connectés à deux machines à souder parce que la tension entre les deux pinces peut être le total de la tension à vide des deux machines.
2. Dans le cas de travail au dessus du niveau du sol, se protéger contre les chutes dans le cas où on recoit un choc. Ne jamais enrouler le câble-électrode autour de n'importe quelle partie du corps.
3. Un coup d'arc peut être plus sévère qu'un coup de soliel, donc:
 - a. Utiliser un bon masque avec un verre filtrant approprié ainsi qu'un verre blanc afin de se protéger les yeux du rayonnement de l'arc et des projections quand on soude ou quand on regarde l'arc.
 - b. Porter des vêtements convenables afin de protéger la peau de soudeur et des aides contre le rayonnement de l'arc.
 - c. Protéger l'autre personnel travaillant à proximité au soudage à l'aide d'écrans appropriés et non-inflammables.
4. Des gouttes de laitier en fusion sont émises de l'arc de soudage. Se protéger avec des vêtements de protection libres de l'huile, tels que les gants en cuir, chemise épaisse, pantalons sans revers, et chaussures montantes.
5. Toujours porter des lunettes de sécurité dans la zone de soudage. Utiliser des lunettes avec écrans latéraux dans les zones où l'on pique le laitier.
6. Eloigner les matériaux inflammables ou les recouvrir afin de prévenir tout risque d'incendie dû étincelles.

7. Quand on ne soude pas, poser la pince à une endroit isolé de la masse. Un court-circuit accidentel peut provoquer un échauffement et un risque d'incendie.
8. S'assurer que la masse est connectée le plus près possible de la zone de travail qu'il est pratique de la faire. Si on place la masse sur la charpente de la construction ou d'autres endroits éloignés de la zone de travail, on augmente le risque de voir passer le courant de soudage par les chaînes de levage, câbles de grue, ou autres circuits. Cela peut provoquer des risques d'incendie ou d'échauffement des chaînes et des câbles jusqu'à ce qu'ils se rompent.
9. Assurer une ventilation suffisante dans la zone de soudage. Ceci est particulièrement important pour le soudage de tôles galvanisées plombées, ou cadmiées ou tout autre métal qui produit des fumées toxiques.
10. Ne pas souder en présence de vapeurs de chlore provenant d'opérations de dégraissage, nettoyage ou pistolage. La chaleur ou les rayons de l'arc peuvent réagir avec les vapeurs du solvant pour produire du phosgène (gaz fortement toxique) ou autres produits irritants.

PRÉCAUTIONS DE SÛRETÉ POUR LES MACHINES À SOUDER À TRANSFORMATEUR ET À REDRESSEUR

1. Relier à la terre le chassis du poste conformément au code de l'électricité et aux recommandations du fabricant. Le dispositif de montage ou la pièce à souder doit être branché à une bonne mise à la terre.
2. Autant que possible, l'installation et l'entretien du poste seront effectués par un électricien qualifié.
3. Avant de faire des travaux à l'intérieur de poste, la débrancher à l'interrupteur à la boîte de fusibles.
4. Garder tous les couvercles et dispositifs de sûreté à leur place.

RETURN TO MAIN INDEX

	Page
Safety	i-iv
<hr/>	
Installation	Section A
Installation Section Table of Contents	A-1
Technical Specifications	A-2
Safety Precautions	A-3
Select Suitable Location (Stacking, Tilting, Lifting)	A-3
High Frequency Interference Protection	A-3
Input Connections	A-4
Reconnect Procedure	A-5
Output Connections	A-7
<hr/>	
Operation	Section B
Safety Instructions	B-2
General Description	B-3
Recommended Processes	B-3
Operational Features and Controls	B-3
Design Features and Advantages	B-3
Welding Capability	B-4
Limitations	B-4
Controls and Settings (Upper and Lower Case Front Controls)	B-5
Welding Operation	B-15
Overload Protection	B-21
Auxiliary Power	B-21
<hr/>	
Accessories	Section C
<hr/>	
Maintenance	Section D
Safety Precautions	D-2
Input Power Factor Capacitor Discharge Procedure	D-2
Routine and Periodic Maintenance	D-3
General Component Locations	D-4
<hr/>	
Theory of Operation	Section E
<hr/>	
Troubleshooting and Repair	Section F
How To Use Troubleshooting Guide	F-2
Troubleshooting Guide	F-4
<hr/>	
Electrical Diagrams	Section G
<hr/>	
Parts Manual	P-196

TABLE OF CONTENTS

- INSTALLATION SECTION -

Installation

Technical Specifications Square Wave TIG 355	A-2
Input and Output Specifications	A-2
Cable and Fuse Sizes.....	A-2
Physical Dimensions	A-2
Safety Precautions	A-3
Select Suitable Location	A-3
Stacking.....	A-3
Lifting	A-3
Tilting	A-3
High Frequency Precautions.....	A-3
Input Connections.....	A-4
Ground Connection	A-4
Input Supply Connections.....	A-4
Reconnect Procedure	A-5
Output Connections.....	A-7
TIG Torch Connection	A-7
Stick Electrode Cable Connection	A-8

INSTALLATION

TECHNICAL SPECIFICATIONS - SQUARE WAVE TIG 355

INPUT - SINGLE PHASE ONLY

<u>Input Voltages:</u> Input Currents @ 350A/34 VDC	<u>208</u> 110	<u>230</u> 100	<u>460</u> 50	<u>575</u> 40
--	------------------------------	------------------------------	-----------------------------	-----------------------------

RATED OUTPUT

<u>Duty Cycle</u> 40% Duty Cycle 60% Duty Cycle 100% Duty Cycle	<u>Amps</u> 350 300 220	<u>Volts at Rated Amperes</u> 34 v 32 v 29 v
---	---	--

OUTPUT

<u>Maximum Open Circuit Voltage</u> 80 Volts Max.	<u>Continuous Current Range</u> 2-400 Amps AC and DC	<u>Auxiliary Power</u> 115 VAC 15 Amps Continuous
---	--	--

RECOMMENDED INPUT WIRE AND FUSE SIZES

		For all Stick, DC TIG, and Balanced AC TIG Welding at 350A/34V/40% Duty Cycle Based on the 1990 U.S. National Electrical Code			For Unbalanced AC TIG Welding Above 230 Amps, 300/32V/60% Duty Cycle, Unbalance Based on the 1990 U.S. National Electrical Code			
Input Voltage / Frequency	Fuse (Super Lag) or Breaker Size	Input Ampere Rating on Nameplate	Type 75°C Copper Wire in Conduit AWG (IEC) Sizes	Type 75°C Copper Ground Wire in Conduit AWG (IEC) Sizes	Input Amperes	Type 75°C Copper Wire in Conduit AWG (IEC) Sizes	Type 75°C Copper Ground Wire in Conduit AWG (IEC) Sizes	Fuse (Super LAG) or Breaker Size
208/60	150	110	4 (25mm ²)	6 (16mm ²)	148	2 (35mm ²)	6 (16mm ²)	200
230/60	125	100	6 (16mm ²)	6 (16mm ²)	134	2 (35mm ²)	6 (16mm ²)	175
460/60	60	50	8 (10mm ²)	10 (6mm ²)	67	6 (16mm ²)	8 (10mm ²)	80
575/60	50	40	8 (10mm ²)	10 (6mm ²)	54	6 (16mm ²)	8 (10mm ²)	70

PHYSICAL DIMENSIONS

<u>Height</u> 884 mm 34.84 in.	<u>Width</u> 565 mm 22.25 in.	<u>Depth</u> 660 mm 26.00 in.	<u>Weight</u> 232 kg 510 lbs.
---	--	--	--

OPERATING TEMPERATURE RANGE STORAGE TEMPERATURE RANGE

0° to 40°C	-50° to 85°C
------------	--------------

SQUARE WAVE TIG 355



Read this entire installation section before you start installation.

SAFETY PRECAUTIONS

⚠ WARNING



ELECTRIC SHOCK can kill.

- Do not touch electrically live parts or electrodes with your skin or wet clothing.
- Insulate yourself from the work and ground.
- Always wear dry insulating gloves.

Only qualified personnel should install, use, or service this equipment.

SELECT SUITABLE LOCATION

Place the Square Wave TIG 355 where clean, cooling air can flow freely in through the side louvers and out through the rear louvers. Keep dust, dirt, and other foreign materials that can be drawn into the machine to a minimum. Failure to observe these precautions can lead to excessive operating temperatures and nuisance shut-downs. Read the section, "High Frequency Interference Protection" before planning the installation.

STACKING

Square Wave TIG 355s may be stacked two high. The bottom machine must be on a stable, hard, level surface. Be sure that the two pins in the roof of the bottom machine fit into the holes in the base of the top machine.

LIFTING

⚠ WARNING

CYLINDER MAY EXPLODE if damaged.

- Do not lift the welder with a cylinder attached.

The Square Wave TIG 355 weighs 510 lbs. (232 kg) without a gas cylinder. Lift the machine by the lift bail only. **Never lift the machine with a cylinder attached.**

TILTING

Place the machine on a secure, level surface or on a recommended undercarriage. Any surfaces you place it on other than the ground must be firm, non-skid, and structurally sound.

HIGH FREQUENCY INTERFERENCE PROTECTION

The spark gap oscillator in the high frequency generator, being similar to a radio transmitter, can be blamed for many radio, TV and electronic equipment interference problems. These problems may be the result of radiated interference. Proper grounding methods can reduce or eliminate radiated interference.

The Square Wave TIG 355 has been field tested under recommended installation conditions. It complies with FCC allowable limits for radiation. For convenience, a certificate of compliance is packed with the welder. It can be used to prove FCC RF Energy Radiation Limits compliance if necessary. (It is the owner's responsibility to obtain this certification.) The Square Wave TIG 355 also complies with NEMA standards for high frequency stabilized power sources.

Radiated interference can develop in the following four ways:

1. Direct interference radiated from the welder.
2. Direct interference radiated from the welding leads.
3. Direct interference radiated from feedback into the power lines.
4. Interference from re-radiation of "pickup" by ungrounded metallic objects.

Keeping these contributing factors in mind, installing equipment per the following instructions should minimize problems.

1. Keep the welder power supply lines as short as possible and completely enclose them in rigid metallic conduit or equivalent shielding for a minimum distance of 50 feet (15.2m). There should be good electrical contact between this conduit and the welder. Both ends of the conduit should be connected to a driven ground and the entire length should be continuous.
2. Keep the work and electrode leads as short as possible and as close together as possible. Lengths should not exceed 25 ft (7.6m). Tape the leads together when practical.

SQUARE WAVE TIG 355



3. Be sure the torch and work cable rubber coverings are free of cuts and cracks that allow high frequency leakage. Cables with high natural rubber content, such as Lincoln Stable-Arc® better resist high frequency leakage than neoprene and other synthetic rubber insulated cables.
4. Keep the torch in good repair and all connections tight to reduce high frequency leakage.
5. The work terminal must be connected to a ground within ten feet of the welder, using one of the following methods.
 - a) A metal underground water pipe in direct contact with the earth for ten feet or more.
 - b) A 3/4" (19mm) galvanized pipe or a 5/8" (16mm) solid galvanized iron, steel or copper rod driven at least eight feet into the ground.

The ground should be securely made and the grounding cable should be as short as possible using cable of the same size as the work cable, or larger. Grounding to the building frame electrical conduit or a long pipe system can result in re-radiation, effectively making these members radiating antennas.

6. Keep all access panels and covers securely in place.
7. All electrical conductors within 50 ft (15.2m) of the welder should be enclosed in grounded, rigid metallic conduit or equivalent shielding. Flexible metallic conduit is generally not suitable.
8. When the welder is enclosed in a metal building, several good earth driven electrical grounds (as in 5 (b) above) around the periphery of the building are recommended.

Failure to observe these recommended installation procedures can cause radio or TV interference problems and result in unsatisfactory welding performance resulting from lost high frequency power.

INPUT CONNECTIONS

Be sure the voltage, phase, and frequency of the input power is as specified on the rating plate, located on the front of the machine.

Welder supply line entry provision is in the case rear panel with a removable cover over the input connection panel area. See Figure A.1.

FIGURE A.1 – REAR PANEL

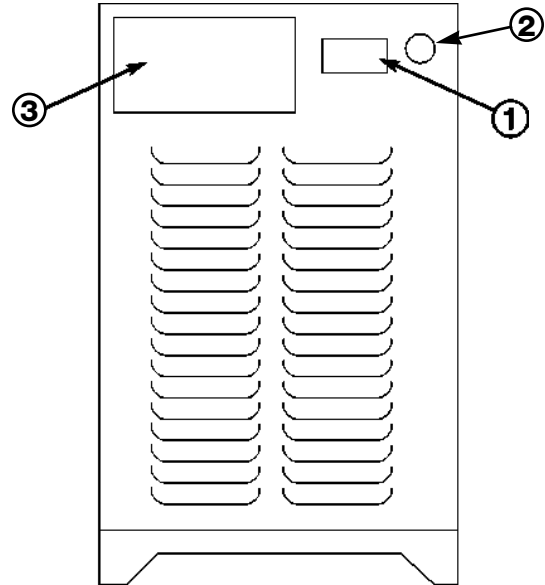

1. WARNING DECAL
2. INPUT POWER ENTRY
3. RECONNECT PANEL COVER

GROUND CONNECTION

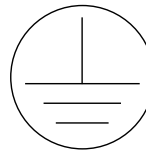

The frame of the welder must be grounded. A ground terminal marked with the symbol is located at the bottom of the input box for this purpose. See your local and national electrical codes for proper grounding methods.

Also follow other grounding instructions given in the section "High Frequency Interference Protection."

INPUT SUPPLY CONNECTION

Be sure the voltage, phase, and frequency of the input power is as specified on the welder nameplate.

⚠ WARNING

ELECTRIC SHOCK can kill.



- Have a qualified electrician install and service this equipment.
- Turn the input power off at the fuse box before working on this equipment.
- Do not touch electrically hot parts.

Have a qualified electrician connect the input power leads to L1 and L2 of the input contactor in accordance with all local codes and national electrical codes. Use a single phase line or one phase of a two or three phase line. Refer to the connection diagram located on the inside of the cover of the Reconnect Panel. Also see Figure A.2.

SQUARE WAVE TIG 355



INSTALLATION

FIGURE A.2 – INPUT SUPPLY CONNECTIONS

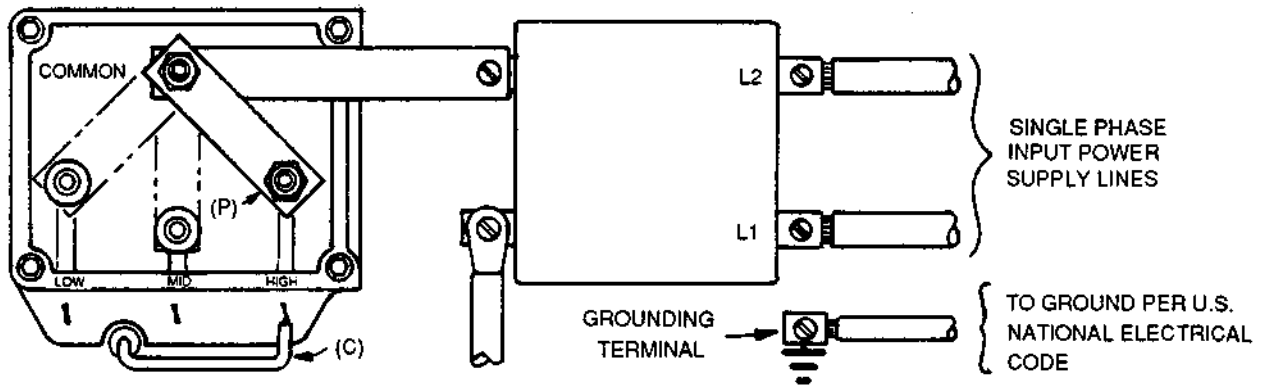

⚠ WARNING



ELECTRIC SHOCK can kill.

- Do not touch electrically live parts or electrodes with your skin or wet clothing.
- Insulate yourself from the work and ground.
- Always wear dry insulating gloves.

Refer to Figure A.2 for the following procedure. Welders are shipped connected for the highest input voltage listed on the rating plate. To change this connection for a different input voltage, reconnect both the power strap (P) and control lead (C) to their respective terminals corresponding to the input voltage used. Designations on reconnect panel, LOW, MID and HIGH, correspond to the nameplate input voltages of a triple voltage welder. Dual voltage welders use only LOW and HIGH. Single voltage welders use only HIGH.

EXAMPLE: On a 208/230/460 volt welder, LOW is 208V, MID is 230V, and HIGH is 460V.

RECONNECT PROCEDURE

On multiple input voltage welders, be sure the reconnect panel is connected according to the following instructions for the voltage being supplied to the welder.

⚠ CAUTION

Failure to follow these instructions can cause immediate failure of components within the welder.

Fuse the input circuit with the recommended super lag fuses or delay type¹ circuit breakers. Choose an input and grounding wire size according to local or national codes or refer to Tables A.1 and A.2. Using fuses or circuit breakers smaller than recommended may result in "nuisance" shut-offs from welder inrush currents even if not welding at high currents.

Unbalanced AC TIG welding draws higher input currents than those for stick, DC TIG, or Balanced AC TIG welding. The welder is designed for these higher input currents. However, where unbalanced AC TIG welding above 230 amps is planned, the higher input currents require larger input wire sizes and fuses. See Table A.2.

¹Also called "inverse time" or "thermal/magnetic" circuit breakers. These circuit breakers have a delay in tripping action that decreases as the magnitude of the current increases.

SQUARE WAVE TIG 355



INSTALLATION

The Square Wave TIG 355 should be permanently wired into the power system. Plugs or connectors are not recommended.

TABLE A.1
RECOMMENDED INPUT WIRE AND FUSE SIZES
 For all Stick, DC TIG, and Balanced AC TIG Welding

Based on the 1990 U.S. National Electrical Code⁽²⁾

40% Duty Cycle

Input Volt/Freq.	Input Ampere Rating on Nameplate	Type 75°C Wire in Conduit AWG Copper Cond.	Grounding Wire AWG Copper Cond.	Fuse Size (Super Lag)
208/60	110	4	6	150
230/60	100	6	6	125
460/60	50	8	10	60
200/50	115	4	6	150
220/50	104	4	6	125
440/50	52	8	10	60

TABLE A.2
RECOMMENDED INPUT WIRE AND FUSE SIZES
 For Unbalanced AC TIG Welding Above 230 AMPS

Based on the 1990 U.S. National Electrical Code⁽²⁾

60% Duty Cycle

Input Volt/Freq.	Input Amperes at 300 Amp Unbalanced AC Output	Type 75°C Wire in Conduit AWG Copper Cond.	Grounding Wire AWG Copper Cond.	Fuse Size (Super Lag)
208/60	148	2	6	200
230/60	134	2	6	175
460/60	67	6	8	80
200/50	154	1	6	200
220/50	140	2	6	200
440/50	70	6	8	90

⁽²⁾ Article 630 of the 1990 U.S. National Electrical Code allows the rated ampacity of the supply conductors to be determined by multiplying the nameplate rating by the appropriate multiplier, depending on the duty cycle of the welder.

SQUARE WAVE TIG 355



Return to Section TOC
 Return to Master TOC
 Return to Section TOC
 Return to Master TOC
 Return to Section TOC
 Return to Master TOC
 Return to Section TOC
 Return to Master TOC

INSTALLATION

OUTPUT CONNECTIONS

⚠ WARNING

ELECTRIC SHOCK can kill.



- Keep the electrode holder, TIG torch and cables insulation in good condition and in place.
- Do not touch electrically live parts or electrode with skin or wet clothing.

- Insulate yourself from work and ground.
- Turn the power off pushbutton on the Square Wave TIG 355 "off" before connecting or disconnecting output cables or other equipment.

See Figure A.3 for the location of the work and electrode terminals, the gas and optional water solenoids, and the Remote Receptacle.

TIG TORCH CONNECTION

TIG welding torches come with 15 ft (4.6m) and 25 ft (7.6m) cables. Use the shorter length whenever possible to minimize possible radio interference problems. With power source off, connect the torch cable to the "Electrode" terminal on the welder. Connect a separate work cable to the "Work" terminal of the welder. See Table A.3 for recommended work cable sizes. Both work and electrode cables should be routed through the cable strain relief holes provided in the base directly below the welding output terminals.

Connect the TIG torch gas and water fittings to the welder fittings. any torch with fittings that conform to Compressed Gas Association (CGA) standards can be used.

The welder fittings have the following threads: Gas Inlet and Outlet: 5/8"-18 right-hand female; Water inlet and Outlet: 5/8"-18 left-hand female. The cylinder of inert shielding gas must be equipped with a pressure regulator and flow meter. Install a hose between the flow meter and gas inlet on the welder.

⚠ WARNING

Observe the safety precautions necessary for handling and using compressed gas containers. Contact your supplier for specific information.

FIGURE A.3 – FRONT PANEL

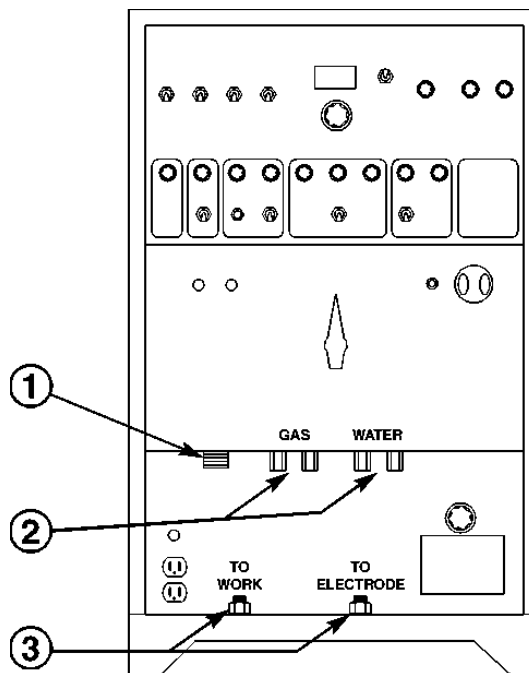

1. REMOTE RECEPTACLE
2. WATER AND GAS SOLENOIDS
3. WORK (LEFT) AND ELECTRODE TERMINALS

TABLE A.3
CABLE SIZES FOR COMBINED LENGTHS OF COPPER ELECTRODE AND WORK CABLE

Machine Size	Lengths up to 100 ft (30 m)	100 to 200 ft (30 to 61 m)	200 to 250 ft (61 to 76 m)
350 Amp 40% Duty Cycle	#1 (45mm ²)	1/0 (55mm ²)	2/0 (70mm ²)

SQUARE WAVE TIG 355



INSTALLATION

DO NOT operate a water-cooled torch unless water is flowing. Water doesn't flow until the solenoid is actuated.

If using a water-cooled torch with a Magnum water cooler, connect the cooler water outlet to the "Water Valve In" fitting. Connect the TIG torch inlet to the "Water Valve Out" fitting.

If using a water-cooled torch with a free-running water supply, install a water line between the welder "Water Inlet" and the supply. Include a strainer in the water supply line to prevent dirt particles from obstructing water flow in the valve and cooling chamber of the TIG torch. Failure to do so could result in water valve malfunction and overheating of the water-cooled torch. Connect the torch water line to the welder "Water Out" fitting. Use a nonmetallic drain line from the electrode connection to the drain or water recirculating pump.

For other water coolers or torches, consult the manufacturer's instructions for the water cooler or TIG torch being used.

STICK ELECTRODE CABLE CONNECTION

Turn the Power switch Off. Run the electrode and work cables through the strain relief holes below the welding output terminals and connect the cables to the proper terminals. This strain relief prevents damage to the welding output terminals if the cables are pulled excessively. Select cable size according to Table A.3

⚠ WARNING

Do not connect a TIG torch and stick electrode cable at the same time. They will both be electrically HOT whenever the output terminals are energized.

Return to Section TOC
Return to Master TOC
Return to Section TOC
Return to Master TOC
Return to Section TOC
Return to Master TOC
Return to Section TOC
Return to Master TOC

SQUARE WAVE TIG 355



TABLE OF CONTENTS - OPERATION SECTION -

Operation.....	Section B
Safety Instructions	B-2
General Description	B-3
Recommended Processes	B-3
Operational Features and Controls	B-3
Design Features and Advantages	B-3
Welding Capability.....	B-4
Limitations	B-4
Controls and Settings	B-5
Upper Case Front Controls	B-5
Lower Case Front Controls	B-11
Hand and Foot Amptrol™ Operation	B-13
Welding Operation	B-15
Initial Start-up.....	B-15
Stick Welding	B-15
TIG Welding Guidelines.....	B-15
TIG Welding Sequence of Operation (2-Step Mode)	B-20
TIG Welding Sequence of Operation (4-Step Mode)	B-20
Overload Protection	B-21
Auxiliary Power	B-21

Return to Master TOC

Return to Master TOC

Return to Master TOC

Return to Master TOC

SQUARE WAVE TIG 355



OPERATION

OPERATING INSTRUCTIONS

Read and understand this entire section of operating instructions before operating the machine.

SAFETY INSTRUCTIONS

WARNING



ELECTRIC SHOCK can kill.

- Do not touch electrically live parts or electrodes with your skin or wet clothing.
- Insulate yourself from the work and ground.
- Always wear dry insulating gloves.



FUMES AND GASES can be dangerous.

- Keep your head out of fumes.
- Use ventilation or exhaust to remove fumes from breathing zone.



WELDING SPARKS can cause fire or explosion.

- Keep flammable material away.
- Do not weld on containers that have held combustibles.



ARC RAYS can burn.

- Wear eye, ear, and body protection.

Observe additional Safety Guidelines detailed in the beginning of this manual.

SQUARE WAVE TIG 355



OPERATION

GENERAL DESCRIPTION

The Square Wave TIG 355 is a constant current, single range square wave AC/DC TIG (GTAW) arc welding power source with built-in high frequency stabilization. It also has stick (SMAW) capability. The Square Wave TIG 355 gives the operator full control of the welding current plus the ability to preset weld and start currents. Preflow and postflow timers are included for shielding gas and cooling water control. Altogether the many features of the machine allow part or all of a weld cycle to be preset or "programmed," which simplifies the TIG welding process.

The Square Wave TIG 355 includes advanced features such as Auto-Balance™ 2-Step/4-Step Arc Start Switch Operation, start controls, crater controls, spot timer, and status LEDs. Preflow and postflow timers allow control of shielding gas and cooling water.

RECOMMENDED PROCESSES

The Square Wave TIG 355 is recommended for TIG (GTAW) and stick (SMAW) welding processes within its output capability of 2 to 400 amps on both AC and DC polarity. It is compatible with all Magnum TIG accessories as well as many industry standard TIG torches, hoses, and water coolers. (See the **Accessories** section of this manual.)

OPERATIONAL FEATURES AND CONTROLS

The following operational controls are standard on the Square Wave TIG 355: Local/Remote current control switch, Stick/TIG mode selection switch, TIG 2-Step/TIG 4-Step mode selection switch, High Frequency Continuous/Start/Off switch, Peak Current control, Volts/Amps switch for the digital ammeter reading, AC Wave Balance control, Afterflow timer for shielding gas and water flow, Arc Force current control for stick welding, Preflow timer for shielding gas and water flow, Spot Time Controls, Start current/time controls, Pulse controls (pulses per second, background % peak current, pulse % on), and Crater Fill controls (fade-out, % peak current).

The following additional features are also standard: Digital ammeter selectable for either volts or amps; Status Indicator LEDs for gas and water, high frequency, arc established, start, peak, background, crater fill.

DESIGN FEATURES AND ADVANTAGES

- Designed to NEMA EW-1 and International IEC-974 Standards.
- Single output range of 2-400 amps covers the majority of TIG welding applications.
- Solid State Output Contactor: no noise, no parts to wear.
- Digital Ammeter and Voltmeter for precise readings from 2-400 amps welding.
- Welding current limit can be preset from 2-400 amps and is displayed on the ammeter when not welding.
- Auto Balance™ circuitry automatically provides the proper amount of cleaning and penetration when AC TIG welding. Manual AC wave balance adjustment is also possible.
- 2-Step/4-Step Arc Start switch capability.
- Spot control for 2-Step Arc Start switch mode.
- TIG Pulsar with On/Off selection, and Pulses Per Second adjustment. Background current and duty cycle are automatically adjusted according to the peak welding current.
- Crater Fill control for current fade-out at the end of a weld.
- Adjustable preflow time from 0 to 10 seconds. Preflow time is eliminated if welding restarts during gas afterflow of previous weld. This avoids unnecessary delays when making repeated welds.
- Adjustable afterflow time control.
- Locate/Remote current selection.
- Stick/TIG selection.
- Arc Force control of added current when electrode shorts to the work in stick mode.
- Continuous/Start/Off High Frequency selection.
- DC+/AC/DC- Polarity switch.
- Power Factor Correction for lower input currents and smaller input wire sizes.
- Remote Receptacle for Amptrol™ or Arc Start switch.
- Low Voltage Arc Start switch circuit (24 VAC) for maximum operator safety.
- Gas and optional water valves: Inlet and outlet fittings conform to Compressed Gas Association (CGA) standards.
- Built-In High Frequency Generator.

SQUARE WAVE TIG 355



OPERATION

- 115 Volt receptacle with 15 amp circuit breaker.
- 220 Volt European (Schuko) type receptacle with 2 amp circuit breaker for water coolers (50/60Hz machines only).
- Excellent arc starting and stability up through 400 amps.
- High resistance to AC arc rectification.
- No tungsten spitting within current range of electrode.
- Compact size, requires only a 22.25 in x 26 in (565 mm 660 mm) footprint.
- Strain relief holes in base for welding cables, gas and water hoses and control cables.
- Easy access for input connections. Connections are simple strip and clamp of input wires (no lugs required).
- Low fan noise at idle.
- Modular construction for easy servicing.
- Unused controls are automatically locked out to simplify setup. Examples: the AC Wave Balance control has no effect in DC; the High Frequency and gas and water valves do not operate in Stick mode; TIG Pulser is locked out in the Stick mode.
- Recessed panels protect controls, output terminals, gas and water fittings.
- Large safety margins and protective circuits protect rectifiers from transient voltages and high currents.
- Line voltage compensated.
- Thermostatically protected.
- Electronic over current protection.

WELDING CAPABILITY

The Square Wave TIG 355 is NEMA Class II (40) Power Source rated 350 amps at 34 volts, 40% duty cycle. The duty cycle is based upon a 10 minute time period. (For 40% duty cycle, it is 4 minutes on and 6 minutes off.) The overload capacity is 375 amps at 35 volts, 30% duty cycle.

The "Lincoln Plus" rating of 300 amps at 40 volts provides additional voltage to overcome voltage drops in long cables when stick welding at high currents.

LIMITATIONS

- The Square Wave TIG 355 is not recommended for arc gouging. The machine's output capacity is too limited.
- The Square Wave TIG 355 is not recommended for AC TIG welding with high concentrations of helium shielding gas. Starting problems and arc rectification may occur.
- The Square Wave TIG 355 is not recommended for pipe thawing.

SQUARE WAVE TIG 355



[Return to Section TOC](#) [Return to Master TOC](#)

OPERATION

CONTROLS AND SETTINGS

UPPER CASE FRONT CONTROLS

Controls on the upper case front control panel are used for manual TIG and stick welding. Their functions are described below. Some controls are active in both TIG and stick welding, while others are active in TIG only. Refer to Figure B.1 for control locations.

FIGURE B.1 - UPPER CASE FRONT CONTROLS

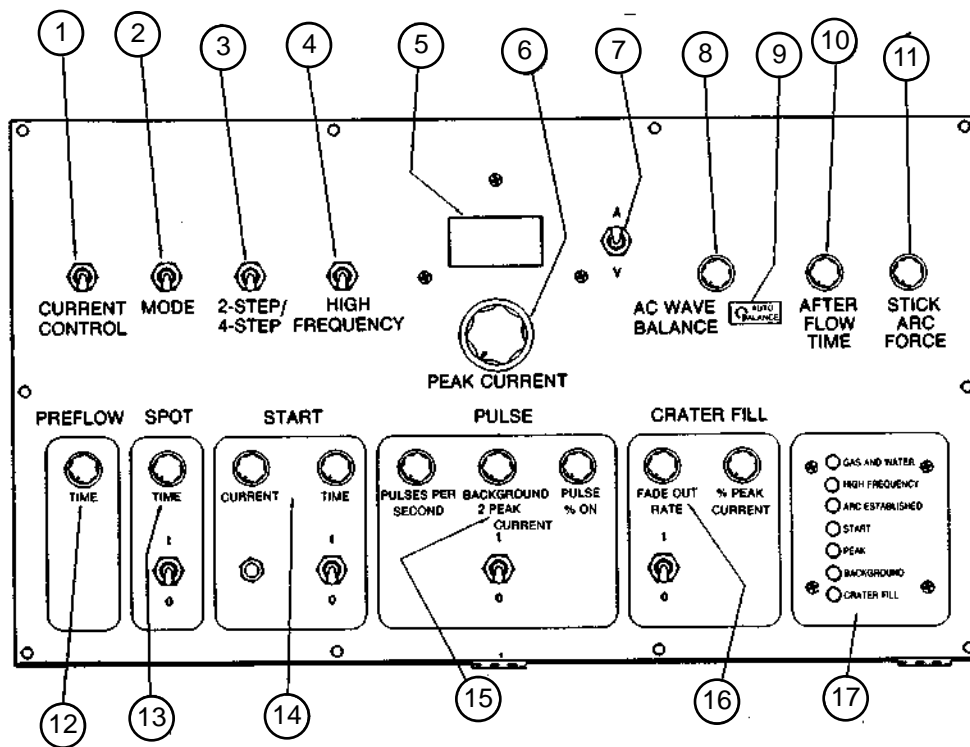

- | | | |
|--|----------------------------|---------------------------|
| 1. REMOTE/LOCAL CURRENT CONTROL SWITCH | 7. VOLTS/AMPS METER SWITCH | 12. PREFLOW TIMER |
| 2. MODE SWITCH (STICK/TIG) | 8. AC WAVE BALANCE | 13. SPOT CONTROLS |
| 3. 2-STEP/4-STEP SWITCH | 9. AUTO-BALANCE™ LED | 14. START CONTROLS |
| 4. HIGH FREQUENCY SWITCH | 10. AFTERFLOW | 15. PULSE CONTROLS |
| 5. DIGITAL VOLTMETER/AMMETER | 11. STICK ARC FORCE | 16. CRATER FILL CONTROLS |
| 6. PEAK CURRENT CONTROL | | 17. STATUS INDICATOR LEDS |

SQUARE WAVE TIG 355



OPERATION

UPPER CASE FRONT CONTROL PANEL

The upper case front panel controls are used for manual TIG and stick welding.

1. CURRENT CONTROL SWITCH

A two-position toggle switch:

LOCAL (PANEL): Current is controlled by the machine settings; remote Amptrol has no effect on current.

REMOTE: Current is controlled by a remote Amptrol up to the current set on the machine.

2. MODE SWITCH

A two-position toggle switch:

STICK: For stick electrode welding (SMAW), this position makes the Stick Arc Force control active. This switch locks out high frequency, the gas and water valves, and the AC Wave Balance control. The STICK position also locks out the Spot Time, Start Time and Crater Fill controls. The Pulse controls are locked out except when an Arc Start switch connected to the Remote receptacle is closed.

TIG: For TIG welding (GTAW), this position locks out the Stick Arc Force control. It makes all other controls active. To start and stop the welding sequence and to get output current, an Amptrol or Arc Start switch must be used when this switch is in the TIG position.

3. 2-STEP/4-STEP SWITCH

A two-position toggle switch: (Locked out in the STICK mode.)

2-STEP: For use with an Arc Start switch or an Amptrol remote current control. The Arc Start switch must be held down during the entire weld cycle. Pressing the Arc Start switch starts the Preflow cycle, and releasing the switch ends the weld cycle.

NOTE: If the Crater Fill switch (Item 16) is ON, welding will continue after the Arc Start switch is released. (See Crater Fill controls.)

4-STEP: For use with an Arc Start switch only. The Arc Start switch must be pressed and released to start the weld cycle. Pressing and releasing the Arc Start switch a second time ends the weld cycle. This eliminates the need to continuously hold down the Arc Start switch during a weld. If the Preflow timer (Item 12) is being used, the Arc Start switch must be held down during the Preflow time. The Arc switch can be released once an arc is established.

NOTE: If the Crater Fill switch (Item 16) is ON, welding will continue after the Arc Start switch is pressed and released the second time. (See Crater Fill Controls.)

NOTE: If the arc goes out while welding in the 4-Step mode, the machine will try to re-establish an arc for a period of two seconds. The output contactor will remain closed, and the High Frequency, if in the Start Only or continuous mode, will be activated. If an arc does not re-establish within two seconds, the weld cycle is automatically ended.

4. HIGH FREQUENCY SWITCH

A three-position toggle switch: (Locked out in STICK mode).

CONTINUOUS: High frequency will come on after the gas Preflow time and remain on until the weld is stopped.

START : High Frequency will come on for 1-2 seconds after an arc is established, then go off. (When AC TIG welding, the high frequency will stay on until after the Start period and come on again during the Crater Fill period.)

OFF: No high frequency.

5. DIGITAL VOLTMETER/AMMETER

Displays the output voltage of the welder when the VOLTS/AMPS switch (Item 7) is held in the "VOLTS" position.

When the VOLTS/AMPS SWITCH IS IN THE "AMPS" position, this display functions as an ammeter.

When you are not welding, the ammeter displays the value preset by the Peak Current control.

When you are not welding and the Start Current Display pushbutton is pressed, the ammeter will display the preset Start (Item 14). (See Start Controls)

NOTE: The ammeter display is an indicator of the preset current. Actual welding current will be slightly different.

While you are welding, the ammeter displays the actual welding current. The ammeter is accurate within $\pm 3\%$ of its reading or ± 2 amps, whichever is greatest. The ammeter displays RMS current. (RMS current is the actual "heating value" of the arc.) NOTE: Some types of ammeters will not accurately read true RMS currents, particularly when AC TIG welding aluminum. AC only ammeters may read as much as 40% low when measuring AC TIG welding currents.

SQUARE WAVE TIG 355



OPERATION

6. PEAK CURRENT CONTROL

Presets the maximum welding current the machine will produce, from 2 through 400 amps. The preset current is displayed on the digital ammeter when you are not welding.

NOTE: The ammeter display is an indicator of the preset current. Actual welding current will be slightly different.

If you use an Amptrol, it will control the current from 2 amps up to the current preset by the Peak Current control. See the section, "Hand and Foot Amptrol Operation" for proper use of hand and foot Amptrols.

If pulsing, the peak current is the current set and controlled by the Peak Current control (Item 6) and the Amptrol.

7. VOLTS/AMPS SWITCH

A two-position, spring-loaded toggle switch for selecting either arc voltage or welding current/preset current to be displayed on the digital meter.

To read the arc voltage, you must hold the switch in the "Volts" position. This spring-loaded switch always returns to the "AMPS" position when released.

8. AC WAVE BALANCE

This control is active only in AC TIG mode. It controls the amounts of positive and negative current in the AC output. It has no effect on stick or DC TIG welding.

AUTO BALANCE™: This setting provides automatic adjustment of the AC wave balance, and it is the preferred balance setting for most welding conditions. This setting gives the ideal amount of cleaning and penetration, based on the welding current output. When the control is set to the Auto Balance position, the Auto Balance LED (Item 9) will light. This feature operates only in the AC TIG mode.

For those procedures when manual adjustment of the Wave Balance control is necessary, use the following as a guide:

BALANCED: The amounts of positive and negative are the same.

CLEANING (Below "3" on the dial): Provides more positive current than negative current. Since the positive current produces the "cleaning" or oxide removal on aluminum, this setting is used for heavily oxidized aluminum.

⚠ CAUTION

Use only the amount of "cleaning" required. Greater amounts of positive current will heat the tungsten more and possibly cause it to melt or "spit." Also, the arc is usually more flared and less stable with more positive "cleaning" current.

PENETRATION (Above "3" on the dial): Provides more negative current than positive current. The "cleaning" effect will be reduced, but the arc plasma will be more concentrated and more easily directed to where the heat is needed. The reduced amount of positive current allows the tungsten to run cooler at a given current than when set balanced.

In general, use just enough "cleaning" to remove oxides and to give good wetting of the puddle.

9. AUTO BALANCE™ LED

Illuminates only when the Auto Balance function is active. The welder must be in the AC TIG mode, with the AC Wave Balance control fully clockwise.

10. AFTERFLOW

This control adjusts the amount of time the gas and water valves stay open after the end of a weld. Minimum time is approximately 5 seconds; maximum is approximately 55 seconds. Use enough Afterflow time to protect the hot tungsten with gas shielding until it cools. Too short of a time will cause the tungsten to oxidize and become contaminated. When in doubt, set a longer time, then reduce it to a time that still gives good protection.

PREFLOW

All machines have an adjustable Prewflow time.

If a new weld is started during the Afterflow time of a previous weld, the Prewflow time is bypassed, since gas shielding is already present. This allows new welds to start immediately, with no preflow delay.

11. ARC FORCE

This control is active only in Stick mode. It controls the amount of current added to the welding current when the electrode shorts to the work.

At Minimum, no extra short circuit current is added. The arc will be softer and will have less spatter but may be more prone to sticking.

SQUARE WAVE TIG 355



OPERATION

At Maximum, the arc will be more forceful and less prone to sticking but will produce more spatter.

12. PREFLOW

This control adjusts the amount of time the gas and water valves are open before the arc starts. It is adjustable from 0 to 10 seconds.

The Prewflow time occurs only if the valves were closed (no gas flow) when the Arc Start switch or Amptrol was pressed. If a new weld is started while the gas valve is still on during the Afterflow time of a previous weld, the Prewflow time is bypassed since gas shielding is already present. This allows new welds to start immediately with no preflow delay.

Note that since the arc cannot start during the Prewflow time, a long Prewflow setting can cause complaints about arc starting. In general, a Prewflow time of 0.5 seconds is satisfactory for most applications.

13. SPOT CONTROLS

Spot Switch — A two-position toggle switch:

Recommended for use in the 2-step Arc Start Switch mode only.

ON: Spot Time control is active. Once the arc is established, the Spot time begins. At the end of the Spot time (or if the Arc Start switch/Amptrol is released sooner), the arc stops. (If Crater Fill [Item 16] is on, downslope begins.)

OFF: Locks out the Spot Time control.

Spot Time Control: Not active if the Spot switch is off. Adjusts weld time from 0.1 to 5 seconds. Weld time is the time from when the arc is fully established until the arc is turned off (or when Crater Fill downslope is started). The Arc Start switch or Amptrol must be held down during the Spot time; if it is released before the end of the Spot time, the arc will be turned off (or Crater Fill started).

14. START CONTROLS

Start Switch — A two-position toggle switch:

ON: Start Current control is active. At the beginning of the weld, current will be the value preset by the Start Current control. The position of the Amptrol has no effect on this current.

OFF: Locks out Start Current and Time controls.

Start Current Display Pushbutton

Press and hold in this pushbutton to display the Start Current preset by the Start Current control. (The Volts/Amps switch (Item 7) must be in the "AMPS" position to read preset current.)

Start Current Control

Locked out if the Start switch is off.

Presets the current that will be provided at the start of the weld. The current can be preset from 2 to 400 amps. The position of the amptrol has no effect on the initial current. The present Start Current is displayed on the Ammeter when the pushbutton is pressed before welding.

A "hot" start is used to quickly heat the tungsten and work, usually on DC TIG welding. Set the Start Current higher than what the welding current will be. After the time is set on the Start Time control, the current will step down to the current set and controlled by the Peak Current control (Item 6) and the Amptrol.

A "soft" start is used to preheat the tungsten and work, usually on AC TIG welding. Set the Start Current lower than what the welding current will be. The arc will establish at the Start Current and then ramp up to the current set and controlled by the Peak Current control (Item 6) and the Amptrol. The time to get up to welding current is set by the Start Time control. During the ramp up, the Amptrol will affect the current that the ramp is going toward and therefore the rate at which the current increases.

Start Time Control

Locked out if the Start switch is off. Adjusts the Start Time from approximately 0.1 to 10 seconds.

15. PULSE CONTROLS

Pulse Switch — A two-position toggle switch:

ON: Pulsing will begin as soon as an arc is established and will continue until the weld is completed. If you are using Start Controls, pulsing begins after the Start Current. If you are using Crater Fill, pulsing will continue during the downslope period.

OFF: Locks out Pulse controls.

Pulses per Second Control — Controls the number of pulses per second from approximately 0.1 to 10 pps. 0.1 pulses per second is slow pulsing (one pulse every 10 seconds); 10 pulses per second is fast pulsing.

Background % Peak Current Control — Controls the background (low pulse) current from zero to 100% of the peak current set and controlled by the Peak Current control (Item 6) and the Amptrol.

SQUARE WAVE TIG 355



OPERATION

Example: The Peak Current control is preset at 50 amps and the Amptrol is partially down, giving a peak current of 30 amps. If the Background Current control is set at 50%, the Background (low pulse) current will be 15 amps.

The Amptrol raises and lowers the Peak current. Since Background current is always a percentage of Peak current, the Amptrol also raises and lowers the Background current.

Pulse % On — Controls the percentage of the pulse cycle that is at the Peak current.

Example: You are pulsing at 1 Pulse per second with a 30% Pulse % On setting. The welding current would be at the Peak current for 0.3 seconds and at the Background current for the remainder of the cycle, 0.7 seconds.

16. CRATER FILL CONTROLS

Use the Crater Fill controls to automatically control current fade-out at the end of a weld. LOCAL current control (Item 1) MUST be used when Crater Fill is used.

Crater Fill Switch — A two-position toggle switch.

ON: Crater Fill Fade-out will begin when the Arc Start Switch or Amptrol is released (2-Step mode) or pressed and released a second time (4-Step mode). If used with Spot Time (item 13), Crater Fill begins at the end of the Spot Time. The current control (item 1) switch must be in LOCAL when using Crater Fill.

OFF: Locks out Crater Fill controls.

Fade-out Control — Controls how slowly the current fades out. The FAST setting will cause current to ramp down from the welding current toward 2 amps in approximately 1/2 second; the SLOW setting, in approximately 20 seconds. The time for downslope to the Crater Fill Current level depends on the difference between the weld current and the Crater Fill Current.

Crater Fill % Peak Current Control — Controls the final Crater Fill current from zero to 100% of the weld current preset on the Peak Current control.

Example: With a Crater Fill % Current setting of 20% and a weld current preset at 100 amps, the current will fade from 100 amps to 20 amps and then dwell at 20 amps for about 1-1/2 seconds before the arc goes out.

The final Crater Fill current dwell time is approximately 1-1/2 seconds, regardless of Crater Fill control settings.

17. STATUS INDICATOR LEDs — Seven Light Emitting Diodes (LEDs) which light when their function is active.

- GAS & WATER LED is on when the solenoid valves are open, from the beginning of Prewflow to the end of Afterflow.
- HIGH FREQUENCY LED is on when the high frequency circuit is on.

FIGURE B.2 – STATUS INDICATOR LIGHT SEQUENCE
SQUARE WAVE TIG 355

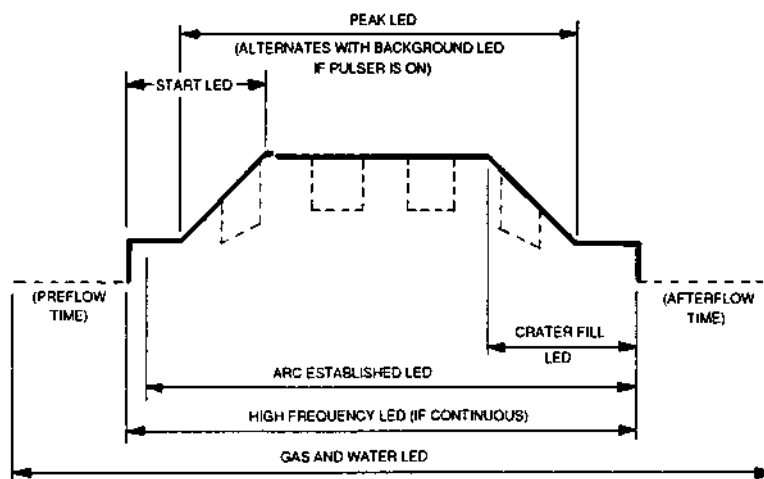

SQUARE WAVE TIG 355



OPERATION

- ARC ESTABLISHED LED goes on when the arc is fully established and goes out if the arc goes out.
- START LED is on from the time the arc is established until current begins to go up (soft start) or down (hot start). Note that the Start LED is off during upslope if a soft start is used.
- PEAK LED goes on after the Start period. If the Pulse switch is on, the Peak LED goes off during the Background periods. The Peak LED and Background LED will alternate when pulsing.
- BACKGROUND LED is on during the Background (low pulse) period of pulsing.
- CRATER FILL LED is on during the Fade-Out downslope and final current periods.

NOTE: An LED will light in response to the control circuit command, even if other components do not work. For example, if the gas supply is turned off or the gas solenoid valve malfunctions or the fuse is blown, the gas will not flow even though the Gas and Water LED lights up. Another example is the High Frequency LED which can light, yet there will not be high frequency due to a blown fuse or defective high frequency circuit or spark gaps set too large.

The Status Indicator LEDs are useful for understanding which functions are active during a weld sequence and for how long. They are useful for setting times of the controls on the Function Panel. See Figure B.2.

The Status Indicator LED circuit board includes a receptacle for plugging in the circuit board included with the Optional Interface Kit.

Return to Section TOC

Return to Section TOC

Return to Section TOC

Return to Section TOC

Return to Master TOC

Return to Master TOC

Return to Master TOC

Return to Master TOC

SQUARE WAVE TIG 355



OPERATION

LOWER CASE FRONT CONTROLS

Refer to Figure B.3 for the location of the following controls.

FIGURE B.3 - LOWER CASE FRONT CONTROLS

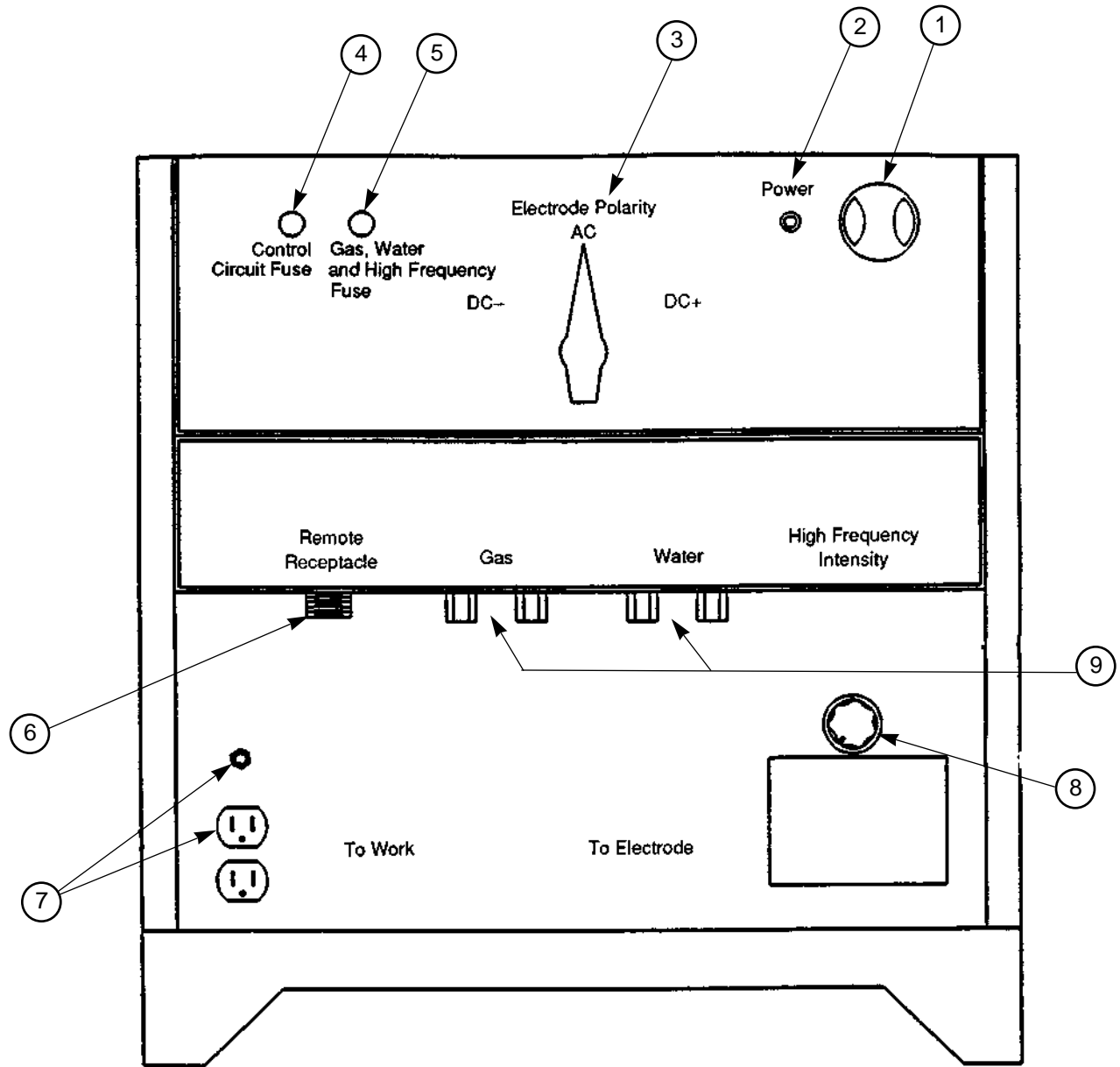

SQUARE WAVE TIG 355



Return to Section TOC

Return to Section TOC

Return to Section TOC

Return to Section TOC

Return to Master TOC

Return to Master TOC

Return to Master TOC

Return to Master TOC

OPERATION

1. **POWER ON/OFF** — A momentary start/stop pushbutton, which controls the input contactor. If the input power supply goes off or if the thermostat in the welder trips, the start pushbutton must be pressed to restart the welder.
2. **PILOT LIGHT** — Indicates when the input contactor is energized (power is on).

⚠ CAUTION

Do not switch polarity under load.

3. **POLARITY SWITCH** — Selects DC-/AC/DC+
4. **FUSE F1** — 0.5 amp control circuit fuse protects the control transformer from overloads. Input overvoltage protection circuitry will blow this fuse to protect electronic components if the input voltage to the welder is too high (more than 40% over rated voltage). If this fuse blows, the digital meters will not light and the input contactor will not latch when the Power On/Off Start pushbutton is pressed and released.
5. **FUSE F2** — 1.5 amp gas, water, and high frequency fuse protects the circuitry that drives the gas and water valves and the high frequency supply transformer. If this fuse blows, the valves and high frequency will not work. However, the LEDs for Gas and Water and High Frequency will still light.
6. **REMOTE RECEPTACLE** — A six-pin circular connector for an Arc Start switch or an Amptrol remote current control.
7. **115 VOLT RECEPTACLE AND CIRCUIT BREAKER** — A duplex 15 amp grounded NEMA 5-15R receptacle and 15 amp circuit breaker. Fifteen amps of 115 volt AC power is available continuously whenever the power is on. The circuit breaker button will pop out if it trips. Reset by pushing it in after the circuit breaker cools and the overload has been removed.
8. **HIGH FREQUENCY INTENSITY CONTROL AND SPARK GAP** — This control changes the high frequency intensity. Use the lowest intensity which still gives good arc starting to minimize Radio Frequency Interference (RFI). The spark gap is set at the factory to the normal setting marked on the cover plate. Instructions for larger or smaller gap settings are also on the cover plate.
9. **GAS AND OPTIONAL WATER VALVES** — Solenoid valves that open at the beginning of the Preflow time and close at the end of the Afterflow time.
The gas valve inlet and outlet are standard 5/8-18 right-hand female fittings. The water valve inlet and outlet are standard 5/8-18 left-hand female fittings. The fittings conform to CGA (Compressed Gas Association) standards. Use a water line strainer to prevent particles from jamming the water valve.

SQUARE WAVE TIG 355



OPERATION

HAND AND FOOT AMPCTRL OPERATION

Both the Hand and Foot Ampctrl (optional kits K870 or K812) work in a similar manner. They are meant to be used for remote current control when Remote Current control is selected. The TIG 2-Step mode must be selected when using an Ampctrl for remote current control. As explained below, Ampctrls can also be used as arc start switches if Local Current control is selected.

For simplicity, the following explanation will refer only to "Ampctrls," meaning both Foot and Hand models. The term "minimum" refers to a Foot pedal in the "up" position, as it would be with no foot pressure, or a Hand Ampctrl in the relaxed position, with no thumb pressure. "Maximum" refers to a fully depressed Foot Ampctrl, or a fully extended Hand Ampctrl.

The Ampctrl is capable of controlling the output current from 2 amps to whatever current is preset on the ammeter. For example, if the ammeter is preset for 200 amps and the Current Control switch is in the Remote position, the Ampctrl, when depressed just past its minimum position, will cause the Square Wave TIG 355 to weld at 2 amps. At the Ampctrl's maximum position, the output would be near 200 amps. See Figure B.4.

▲ CAUTION

Since the full output of the current setting is available when the Ampctrl is fully depressed, care must be taken not to set a current which will exceed the current carrying capacity of the tungsten. When in doubt, use a lower current setting first, then increase.

It is important to note that, for many applications, the tungsten will not start an arc at only 2 amps. To start an arc reliably, it is important to depress the Ampctrl far enough so that the machine output current is near the tungsten operating range. (See Table B.2 for recommended tungsten currents.) In the example above, a 3/32" (2.4 mm) tungsten may be used on DC- to weld near 200 amps. To start the weld, the operator may have to depress the Ampctrl approximately 1/4 of the way down, or to nearly 70 amps, in order to start the arc. Merely depressing the Ampctrl to its 2 amp minimum position will not start the arc.

A similar situation occurs when the Start controls are used. For example, a 3/32" (2.4 mm) tungsten is again used for welding DC- up to 200 amps (preset on the ammeter). A Start current of 50 amps is set on the Start Level control. When you depress the Ampctrl, the start circuitry sets the output current to 50 amps. If the Ampctrl is kept near the minimum position, at the end of the start period the output current will drop to 2 amps, causing the arc to go out in most cases. Depress the Ampctrl at least 1/4 of the way down, or to around 70 amps, so that the tungsten remains lit when the start period ends.

The same holds true for a "hot" start, or one in which the Start current is set to a current higher than the current preset on the ammeter. Again, at the end of the start period, the Ampctrl must be depressed far enough so that the machine output will be high enough to keep the arc lit.

The best technique when using the start controls and an Ampctrl is to press the Ampctrl to maximum at the beginning of the weld, wait until the end of the start period, and then back off on the ampctrl only if the current is too high.

If the Current Control switch is set to the Local position, an Ampctrl can be used as an arc start switch. Depressing the ampctrl just past minimum will cause the Ampctrl's built-in arc start switch to close, and backing off completely causes the built-in start switch to open. The Ampctrl will have no effect on the welding current when used as an arc start switch. See Figure B.5.

SQUARE WAVE TIG 355



OPERATION

FIGURE B.4 - AMPTROLS USED WITH CURRENT CONTROL IN THE LOCAL POSITION

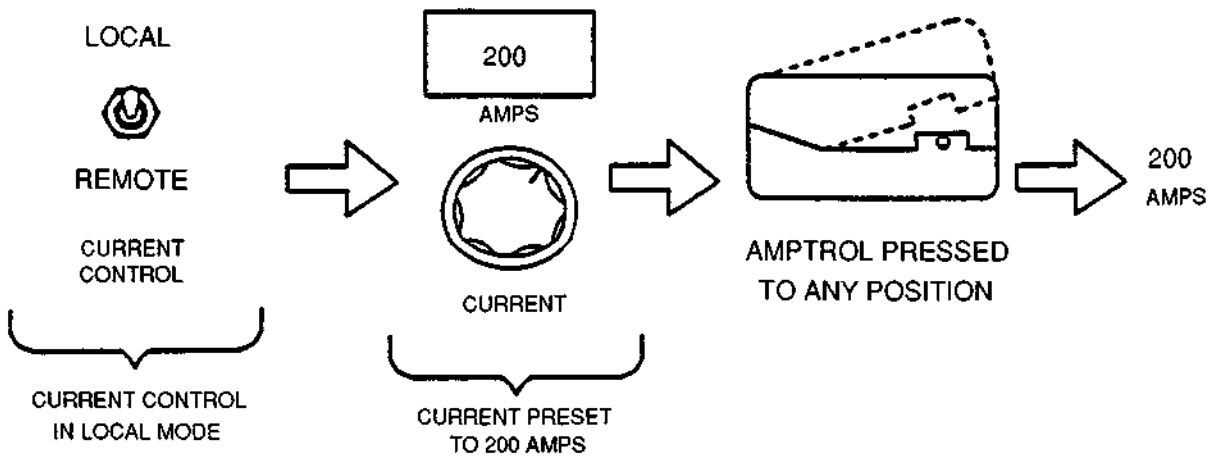
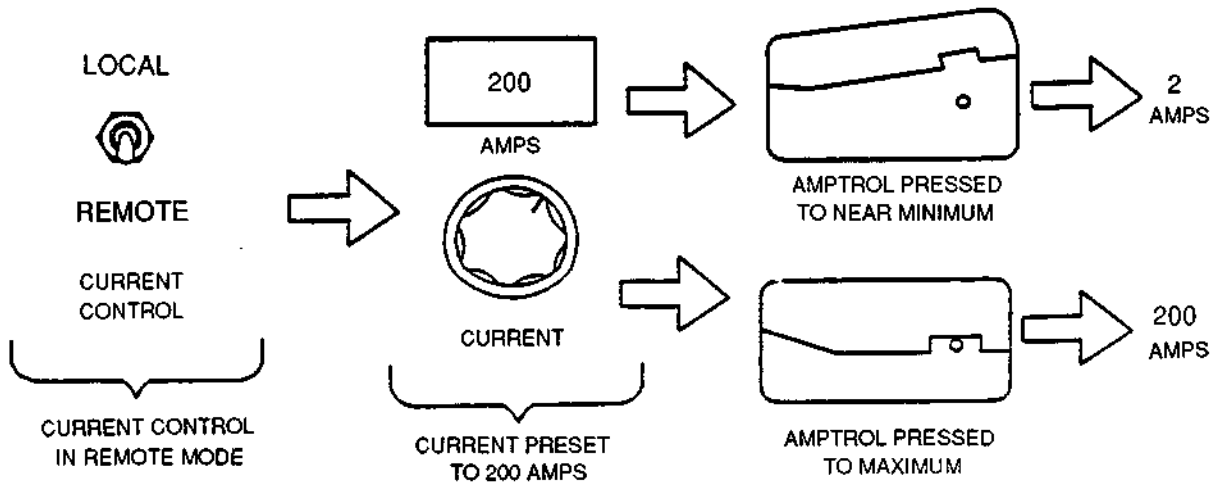

FIGURE B.5 - AMPTROLS USED WITH CURRENT CONTROL IN REMOTE POSITION



SQUARE WAVE TIG 355



Return to Section TOC

Return to Section TOC

Return to Section TOC

Return to Section TOC

Return to Master TOC

Return to Master TOC

Return to Master TOC

Return to Master TOC

OPERATION

WELDING OPERATION

INITIAL START-UP

Be sure the Square Wave TIG 355 has been installed correctly with respect to location, high frequency protection, input power, and output connections.

If you are TIG welding, connect a K870 or K812 Amptrol or a K814 Arc Start switch to the Remote Receptacle. Check that the gas supply is on. Check for the correct type and size of tungsten electrode, gas cone size and torch size. If you are using a water cooled torch, check that the water supply is on.

Press the Start (green) Power pushbutton. The input contactor will pull in, the pilot light will come on, the meter displays will light up, and the fans will start. In TIG mode, the gas and water valves will open for one Afterflow period to purge the lines. The ammeter will display the preset current (if there is no load on the welder output terminals). The voltmeter will read zero in TIG mode, or from 60 to 70 in STICK mode.

Select the Electrode Polarity needed (DC-/AC/DC+).

Set the controls by going from left to right across the top row and then the bottom row, choosing the correct setting for each. Note that the bottom row of controls includes on/off switches to easily lock out the controls within blocks (Spot, Start, Pulse, or Crater Fill) without changing the settings. Also, note that some of the controls are automatically locked out internally if they do not apply in STICK mode or do not apply in TIG mode. This reduces the number of controls which must be set. See Table B.1 for examples of the effects of the Function controls on TIG welding.

STICK WELDING

1. Remove the Amptrol or Arc Start switch from the Remote Receptacle.
2. Turn the welder on. The pilot light on the front panel indicates when the power is on.
3. Select LOCAL current control;

Select STICK mode. (High Frequency switch has no effect in STICK mode.)

4. Preset the current with the Current control and the Ammeter.
5. Set the desired Arc Force. (See CONTROLS AND SETTINGS, item 11, "Arc Force.") (The Wave Balance and Afterflow controls have no effect in STICK mode.)
6. Turn the Start switch OFF, or set the START controls for a hot start if needed. (See CONTROLS AND SETTINGS, item 14, "Start Controls.")
7. Strike an arc and weld. (There will be a buzzing sound from the arc if you are AC welding, due to the faster rate of current reversal of the Square Wave.

TIG WELDING GUIDELINES

Recommended tungsten electrode sizes, stickouts, currents, cup or nozzle sizes and gas flow are shown in Table B.2. SINCE TIG APPLICATIONS CAN VARY, THIS TABLE IS INTENDED AS A GUIDE ONLY.

Aluminum Welding: Set the Electrode Polarity switch to AC, the High Frequency switch to CONTINUOUS, and the Mode switch to TIG. Make all other control settings to suit the size tungsten and current. In general, pure or zirconiated tungsten electrode is best for aluminum and should have a "balled" end not exceeding the diameter of the tungsten. A buzzing sound will occur in the arc when AC TIG welding aluminum. We recommend that you set the AC Wave Balance control to the Auto Balance position. For more information see CONTROLS AND SETTINGS, item 8, "AC Wave Balance."

Stainless or Mild Steel Welding: Set the Electrode Polarity switch to DC-, the High Frequency switch to START, and the Mode switch to TIG. In general, 1% or 2% thoriated tungsten electrode is best for stainless or mild steel and should have the end ground to a point. If there is difficulty starting the arc, the tungsten may be contaminated, or it may be too large to get up to operating temperature.

Note: Starting difficulties may often be due to not pressing the Amptrol far enough. When the Amptrol is just "cracked," the minimum current (2 amps) is produced. Pressing the Amptrol more at the start of the weld will often solve starting problems.

SQUARE WAVE TIG 355



OPERATION

TABLE B.1
SPECIFIC EFFECTS OF CONTROLS
 (illustrated in the 2-Step Mode for clarity)

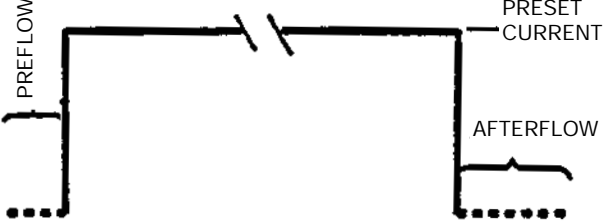
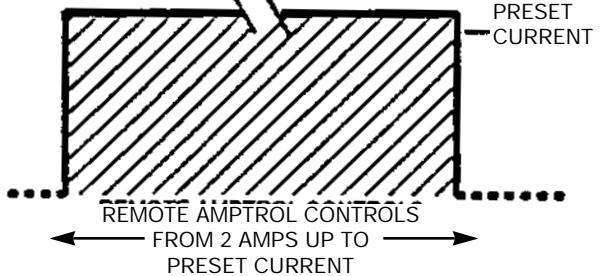
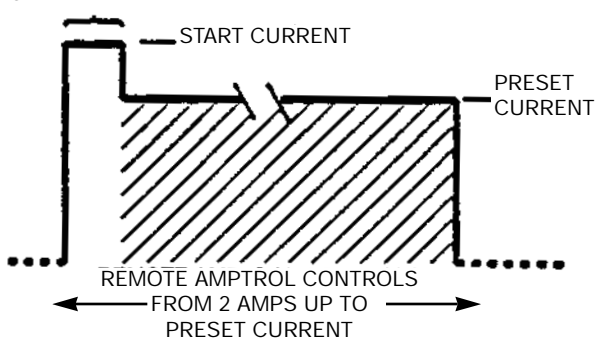
<p>CLOSE ARC START SWITCH</p> <p>WELD BEGINS</p> <p>OPEN ARC START SWITCH</p>	<p>EFFECT OF CONTROLS ON TIG WELDING</p>
	<p>LOCAL CURRENT CONTROL ALL LOWER PANEL SWITCHES OFF</p>
	<p>REMOTE CURRENT CONTROL ALL LOWER PANEL SWITCHES OFF</p>
	<p>LOCAL OR REMOTE CURRENT CONTROL START SWITCH ON START CURRENT SET HIGHER THAN PRESET CURRENT (HOT START) START TIME: VARIABLE ALL OTHER PANEL SWITCHES OFF</p>

HOT START

Return to Section TOC

Return to Section TOC

Return to Section TOC

Return to Section TOC

Return to Master TOC

Return to Master TOC

Return to Master TOC

Return to Master TOC

OPERATION

Return to Section TOC
Return to Master TOC

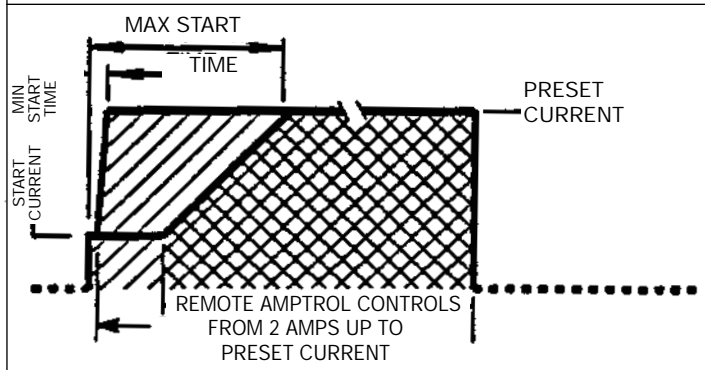
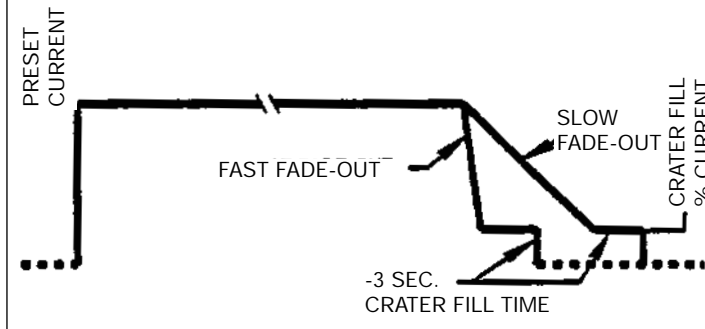
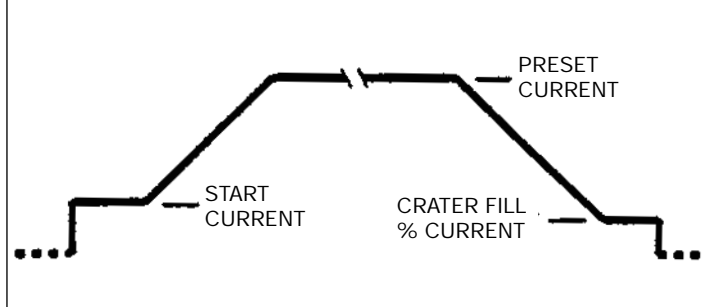
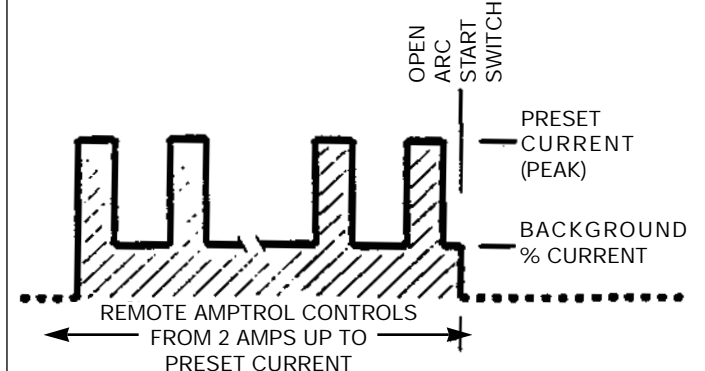
<div style="display: flex; justify-content: space-between;"> CLOSE ARC START SWITCH WELD BEGINS OPEN ARC START SWITCH </div>	EFFECT OF CONTROLS ON TIG WELDING	
	<p>LOCAL OR REMOTE CURRENT CONTROL START SWITCH ON START CURRENT SET LOWER THAN PRESET CURRENT (SOFT START) START TIME: VARIABLE ALL OTHER PANEL SWITCHES OFF</p>	SOFT START
	<p>LOCAL CURRENT CONTROL CRATER FILL SWITCH ON CRATER FILL % CURRENT VARIABLE FADE-OUT VARIABLE ALL OTHER LOWER PANEL SWITCHES OFF</p>	CRATER FILL
	<p>LOCAL CURRENT CONTROL START SWITCH ON (SOFT START SHOWN; MAY HAVE HOT START) CRATER FILL SWITCH ON ALL OTHER PANEL SWITCHES OFF</p>	START & CRATER FILL
	<p>LOCAL OR REMOTE CURRENT CONTROL PULSE SWITCH ON PULSES PER SECOND BACKGROUND % DUTY CYCLE PULSE % ON ALL OTHER LOWER PANEL SWITCHES OFF</p>	PULSE

SQUARE WAVE TIG 355



OPERATION

Return to Section TOC
Return to Master TOC

<p>CLOSE ARC START SWITCH</p> <p>WELD BEGINS</p> <p>OPEN ARC START SWITCH</p>	<p>EFFECT OF CONTROLS ON TIG WELDING</p>	
	<p>LOCAL CURRENT CONTROL START SWITCH ON (SHORT HOT START SHOWN) PULSE SWITCH ON CRATER FILL SWITCH ON (SLOW FADE-OUT SHOWN) SPOT SWITCH OFF</p>	<p>START & PULSE & CRATER FILL</p>
	<p>LOCAL OR REMOTE SPOT SWITCH ON ALL OTHER LOWER PANEL SWITCHES OFF</p> <p>(SPOT TIME IS CUT SHORT IF ARC START SWITCH IS OPENED BEFORE END OF SPOT TIME)</p>	<p>SPOT</p>
<p>THE SPOT TIMER CAN BE USED TO TIME A PROGRAMMED SEQUENCE OF START AND/OR PULSE UP TO 5 SECONDS LONG, OPTIONALLY FOLLOWED BY CRATER FILL. IF CRATER FILL IS USED, FADE-OUT BEGINS AT THE END OF THE SPOT TIME.</p>		<p>SPOT & START PULSE & CRATER FILL</p>

SQUARE WAVE TIG 355



OPERATION

**TABLE B.2
TYPICAL CURRENT RANGES⁽¹⁾ FOR TUNGSTEN ELECTRODES⁽²⁾**

Tungsten Electrode Diameter in. (mm)	DCEN (-)	DCEP (+)	AC				Approximate Argon Gas Flow Rate C.F.H. (l/min)		TIG Torch Nozzle Size ^{(4), (5)}
			Unbalanced Wave		Balanced Wave		Aluminum	Stainless Steel	
			Pure Tungsten	1%, 2% Thoriated Tungsten Zirconated	Pure Tungsten	1%, 2% Thoriated Tungsten Zirconated			
.010 (.25)	2-15	⁽³⁾	2-15	2-15	2-15	—	3-8 (2-4)	3-8 (2-4)	4,5,6
0.020 (.50)	5-20	⁽³⁾	5-15	5-20	10-20	5-20	5-10 (3-5)	5-10 (3-5)	
0.040 (1.0)	15-80	⁽³⁾	10-60	15-80	20-30	20-60	5-10 (3-5)	5-10 (3-5)	
1/16 (1.6)	70-150	10-20	50-100	70-150	30-80	60-120	5-10 (3-5)	9-13 (4-6)	5,6
3/32 (2.4)	150-250	15-30	100-160	140-235	60-130	100-180	13-17 (6-8)	11-15 (5-7)	6,7,8
1/8 (3.2)	250-400	25-40	150-210	225-325	100-180	160-250	15-23 (7-11)	11-15 (5-7)	
5/32 (4.0)	400-500	40-55	200-275	300-400	100-240	200-320	21-25 (10-12)	13-17 (6-8)	8,10
3/16 (4.8)	500-750	55-80	250-350	400-500	190-300	290-390	23-27 (11-13)	18-22 (8-10)	
1/4 (6.4)	750-1000	80-125	325-450	500-630	250-400	340-525	28-32 (13-15)	23-27 (11-13)	

(1) When used with argon gas. The current ranges shown must be reduced when using argon/helium or pure helium shielding gases.

(2) Tungsten electrodes are classified as follows by the American Welding Society (AWS):

- PureEWP
- 1% ThoriatedEWTh-1
- 2% ThoriatedEWTh-2

Though not yet recognized by the AWS, Ceriated Tungsten is now widely accepted as a substitute for 2% Thoriated Tungsten in AC and DC applications.

(3) DCEP is not commonly used in these sizes.

(4) TIG torch nozzle "sizes" are in multiples of 1/16ths of an inch:

- # 4 = 1/4 in. (6mm)
- # 5 = 5/16 in. (8mm)
- # 6 = 3/8 in. (10mm)
- # 7 = 7/16 in. (11mm)
- #8 = 1/2 in. (12.5mm)
- #10 = 5/8 in. (16mm)

(5) TIG torch nozzles are typically made from alumina ceramic. Special applications may require lava nozzles, which are less prone to breakage, but cannot withstand high temperatures and high duty cycles. Currents above 350 amps require metal nozzles on water cooled torches.

Return to Section TOC
Return to Master TOC

OPERATION

TIG WELDING SEQUENCE OF OPERATION (2-STEP MODE)

⚠ WARNING

Do not leave stick electrode welding cable connected. It will be electrically "hot" when TIG welding.

1. Connect an Amptrol or Arc Start switch to the Remote Receptacle.
2. Turn the welder, water supply (if equipped) and gas supply on. The pilot light on the front panel indicates when the power is on.
3. Select REMOTE or LOCAL current control (REMOTE requires an Amptrol).

Select TIG mode.

Select CONTINUOUS or START high frequency.

Select AC or DC- electrode polarity. See Table B.3 for recommended polarity settings.

**TABLE B.3
RECOMMENDED SETTINGS FOR TIG WELDING**

Type of Welding	Electrode Polarity	High Frequency Switch
Stainless Steel	DC-	Start
Aluminum and Magnesium	AC	Continuous
Other Metals	DC-	Start

4. Preset the maximum current with the Current control and the Ammeter.
5. (Arc Force control has no effect in TIG mode.)
6. If in AC, set AC Wave Balance control. (See CONTROLS AND SETTINGS, item 8, "AC Wave Balance." This control has no effect in DC.)
7. Set Afterflow time.
8. Set Function Panel controls as needed. (See CONTROLS AND SETTINGS.)
9. Press the Arc Start switch or Amptrol and set the gas flowmeter. The welder is now ready for welding.
10. Position the tungsten electrode at the start of the weld at a 65° to 75° angle with the horizontal so that the electrode is approximately 1/8" (3.2 mm) above the workpiece. Press the Arc Start switch or operate the Amptrol. This opens the gas and water valves to automatically purge air from the

hose and torch. After a time determined by the Preflow control setting, the high frequency becomes available to strike the arc.

11. Hold the Arc Start Switch down or operate the Amptrol until the weld is completed. Release the Arc Start switch or the Amptrol to stop the arc. When the Afterflow timer completes the cycle, the gas and water valves close. To make another weld, repeat steps 10 and 11.

TIG WELDING SEQUENCE OF OPERATION (4-STEP MODE)

⚠ WARNING

Do not leave stick electrode welding cable connected. It will be electrically "hot" when TIG welding.

1. Connect an Arc Start switch to the Remote Receptacle.
2. Turn the welder, water supply (if so equipped) and gas supply on. The pilot light on the front panel indicates when the power is on.
3. Select LOCAL current control. Select TIG mode. Select CONTINUOUS or START high frequency. Select AC or DC- electrode polarity (See Table B.3 for recommended polarity settings).
4. Preset the maximum current with the Peak Current control and the Ammeter.
5. (Arc Force Control has no effect in TIG mode.)
6. If in AC, set AC Wave Balance control. (See CONTROLS AND SETTINGS, item 8, "AC Wave Balance. This control has no effect in DC.)
7. Set Afterflow time.
8. Set Function Panel controls as needed. (See CONTROLS AND SETTINGS, "Lower Case Front Controls")
9. Press the Arc Start switch and set the gas flowmeter. The welder is now ready for welding.
10. Position the tungsten electrode at the start of the weld at a 65° to 75° angle with the horizontal so that the electrode is approximately 1/8" (4 mm) above the workpiece. Press the Arc Start switch. This opens the gas and water valves to automatically purge air from the hose and torch. After a time determined by the Preflow control setting, the high frequency becomes available to strike the arc.

SQUARE WAVE TIG 355



Return to Section TOC
Return to Master TOC
Return to Section TOC
Return to Master TOC
Return to Section TOC
Return to Master TOC
Return to Section TOC
Return to Master TOC

OPERATION

11. Hold the Arc Start switch down until an arc is established. At this point, the Arc Start Switch can be released, and the weld will continue. Press and release the Arc Start switch a second time to stop the arc. When the Afterflow timer completes the cycle, the gas and water valves close. To make another weld, repeat steps 10 and 11.

Note: Starting difficulties may often be due to not pressing the Amptrol far enough. When the Amptrol is just "cracked," the minimum current (2 amps) is produced. Pressing the Amptrol more at the start of the weld will often solve starting problems.

OVERLOAD PROTECTION

The Square Wave TIG 355 has thermostatic protection from overloads, loss of cooling, and high ambient temperatures. When the welder is subjected to an overload or loss of cooling, a thermostat will open.

If the *secondary* thermostat opens, the effect will be the same as pushing the Stop power pushbutton: the power will go off, the pilot light and meters will go out, and the fans will stop. Pressing the Start power pushbutton after the thermostat cools and resets will restart the welder.

If the *primary* thermostat opens, the power will stay on (pilot light and meters on and fans running), but no more than 5 amps DC output current will be available. This allows the fans to cool the machine. Depending on the amount of welder overload, the thermostat should reset within five minutes with the fan motors running. When the primary thermostat cools and resets, normal output current will be available.

AUXILIARY POWER

ALL MACHINES

The Square Wave TIG 355 provides 15 amps of 115 volt AC power at a standard NEMA 5-15R receptacle, located on the lower case back of the machine. This circuit is protected from shorts and overloading by a 15 amp circuit breaker, located next to the receptacle. The auxiliary circuit is intended for running water coolers and small power tools, whose current draw is within the 15 amp rating.

50/60Hz MACHINES

Square Wave TIG 355 machines rated for 50/60Hz operation provide 2 amps of 220 volt AC power at a continental European (Schuko) type receptacle, located on the lower case back of the machine. This circuit is protected from shorts and overloading by a 2 amp circuit breaker, located above the receptacle. The auxiliary circuit is intended for running water coolers whose current draw is within the 2 amp rating of the receptacle.

CAUTION

Note that some types of equipment, especially pumps and motors, have starting currents significantly higher than their running currents. These higher starting currents may cause the circuit breaker to open. If this situation occurs, the user should avoid using the Square Wave TIG 355 auxiliary for that equipment.

TABLE OF CONTENTS - ACCESSORIES -

Accessories.....Section C
Options/Accessories.....C-2

Return to Master TOC
Return to Master TOC
Return to Master TOC
Return to Master TOC



ACCESSORIES

OPTIONS/ACCESSORIES

The following options/accessories are available for your Square Wave TIG 355 from your local Lincoln Electric Distributor.

Undercarriage (K841) – Includes a platform, wheels, and brackets for supporting the welder and two gas cylinders.

Pump Mounting Platform (K827) – Mounts on top of the welder to provide a mounting surface suitable for water recirculating pumps.

Arc Start Switch (K814) – Starts the welding sequence if remote control for TIG welding is not desired. Plugs into the Remote Receptacle. The Current Control switch must be in the LOCAL position when using the Arc Start switch; only a minimum current (2 amp) is available in REMOTE. Includes 25 ft. (7.6 m) cable.

Interface Kit (K846) – Mounts to the back of the LED status PC board. Provides six isolated circuits that can be closed to provide status indication when each of the following functions is active: High Frequency, Arc Established, Start, Pulse Peak, Pulse Background, and Crater Fill. Each circuit occupies two positions on a terminal strip and consists of a fuse, fuse holder, and sockets for an industry standard, optically isolated Solid State Relay (SSR) module (purchased separately, see below).

Solid State Relays (SSRs):

K847-DC – Can switch up to 40VDC, 2 amps maximum load. Package of two.

K847-AC – Can switch up to 130VAC, 2 amp maximum load. Package of two.

Amptrol™ (K870 or K812) – Provides a remote current control for most TIG welding applications. Model K870 is a foot operated control; model 812 is hand operated. Both models plug into the remote control receptacle. A separate switch on the Amptrol starts the welding sequence. When the Current Control switch on the welder is set in the LOCAL position, the Amptrol works as an arc start switch only; it does not control current. (Current is controlled by the rheostat on the front panel.) When the Current Control switch on the welder is set to the REMOTE position, current is controlled by the Amptrol, in a range from 2 amps up to the current set on the control panel. For a more detailed explanation of Amptrol operation, see the Operation Section of this manual.

¹Use of the Synergic 7 wire feeder requires appropriate input cable assembly, wire stand, and drive roll kit. Refer to Synergic 7 Operator's Manual for available options.

TABLE OF CONTENTS -MAINTENANCE-

MaintenanceSection D

 Safety Precautions.....D-2

 Input Filter Capacitor Discharge ProcedureD-2

 Routine and Periodic MaintenanceD-3

 General Component Locations.....D-4

Return to Master TOC

Return to Master TOC

Return to Master TOC

Return to Master TOC



MAINTENANCE

SAFETY PRECAUTIONS

WARNING



- Only Qualified personnel should perform this maintenance.
- Turn the input power OFF at the disconnect switch or fuse box before working on this equipment.
- Do not touch electrically hot parts.

INPUT POWER FACTOR CAPACITOR DISCHARGE PROCEDURE

This procedure ensures that the power factor capacitors are discharged, for greater safety when you are working on the Square Wave TIG 355 with INPUT POWER REMOVED.

1. Remove input power to the machine.
2. With a 5/16" nut driver, remove the sheet metal screws that hold the right case side in place. Remove the right case side.
3. With a volt/ohmmeter, carefully check the voltage across the input power factor capacitors. When input power is removed, the voltage across each capacitor should be zero. (Normally, the capacitors discharge through the primary winding in the main transformer.)
4. If capacitor voltage is zero, you may begin working on the Square Wave TIG 355.

5. If any voltage is present, DISCHARGE EACH INDIVIDUAL CAPACITOR as follows:
 - a. Obtain a 500 Ohm resistor. Grip the 500 ohm resistor with insulated gloves and insulated gripping pliers and hold the resistor across the terminals on each capacitor for 20 seconds. See Figure D.1.
 - b. With the volt/ohmmeter, recheck each capacitor for voltage.
 6. After all the capacitors are discharged completely, check for broken capacitor leads or an open primary winding on the main transformer, which would have prevented the capacitors from discharging normally.
2. Periodically blow out dust and dirt from the inside of the machine with a low pressure air system. Be sure to clean the following components thoroughly. See Figure D.2 for their location.
 - Main transformer
 - Output terminals (located on case front)
 - Polarity switch (located on case front)
 - Rectifier assembly
 - Control box assembly
 - Spark gap assembly
 - Protection PC board
 3. Inspect the welder output terminals and control cables for fraying, cuts, and bare spots.
 4. Inspect the spark gap spacing at regular intervals. To access the spark gap, remove the nameplate located on the lower right section of the output panel. **Maintain the gap marked on the machine cover plate.** Please note the following:
 - If more intensity is needed than is available with the "High Frequency" set to MAXIMUM, increase the spark gap according to the intervals on the cover plate. (To minimize RFI problems, use the smallest possible spark gap setting that still provides good welding.)
 - Do not dress or refinish the spark gap contacts. Replace the electrodes if the contact surfaces become irregular or completely eroded.

ROUTINE AND PERIODIC MAINTENANCE

⚠ WARNING

To avoid receiving a high frequency shock, keep electrode holders, TIG torches and cable insulation in good condition.

1. Disconnect power supply lines to the machine before performing periodic maintenance.
5. The fan motors have sealed ball bearings and require no maintenance.

FIGURE D.1 - POWER FACTOR CAPACITOR DISCHARGE DETAILS

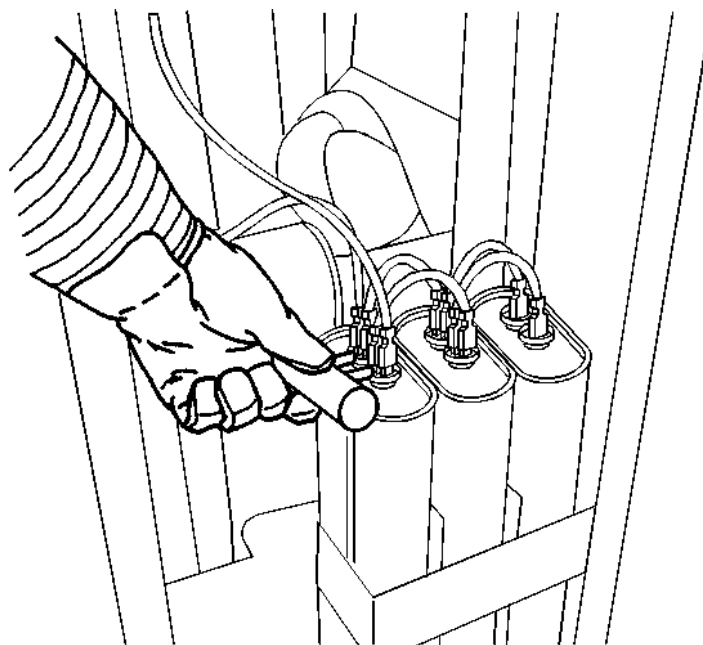
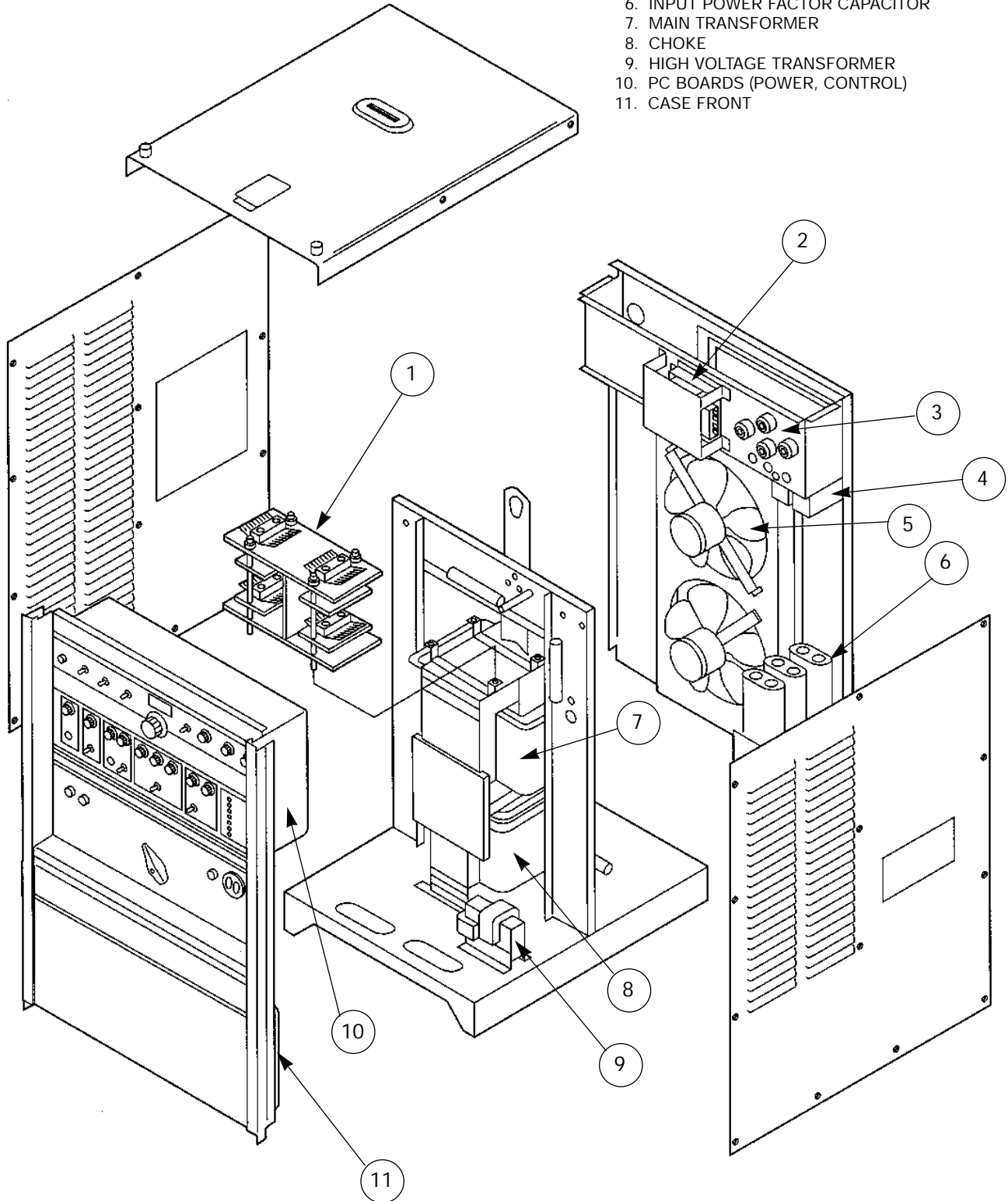

FIGURE D.2 - GENERAL COMPONENT LOCATIONS

1. OUTPUT RECTIFIER/SCR BRIDGE ASSEMBLY
2. INPUT CONTACTOR
3. RECONNECT PANEL
4. PILOT TRANSFORMER
5. FAN AND FAN MOTOR
6. INPUT POWER FACTOR CAPACITOR
7. MAIN TRANSFORMER
8. CHOKE
9. HIGH VOLTAGE TRANSFORMER
10. PC BOARDS (POWER, CONTROL)
11. CASE FRONT



SQUARE WAVE TIG 355
LINCOLN
ELECTRIC

TABLE OF CONTENTS -THEORY OF OPERATION SECTION-

Theory of Operation	Section E
General Description	E-2
Input Power Circuit: Input Voltage, Contactor, Reconnect Panel, Pilot Transformer, Control Transformer, Power Factor Capacitors, and Main Transformer.....	E-2
Output Rectification and Feedback Control	E-3
High Voltage/High Frequency Circuit.....	E-4
DC Welding Output	E-5
AC Welding Output	E-6
SCR Operation	E-7
Protective Circuits.....	E-8
Thermal Protection	E-8
Overload Protection.....	E-8

FIGURE E.1 – SQUARE WAVE TIG BLOCK LOGIC DIAGRAM

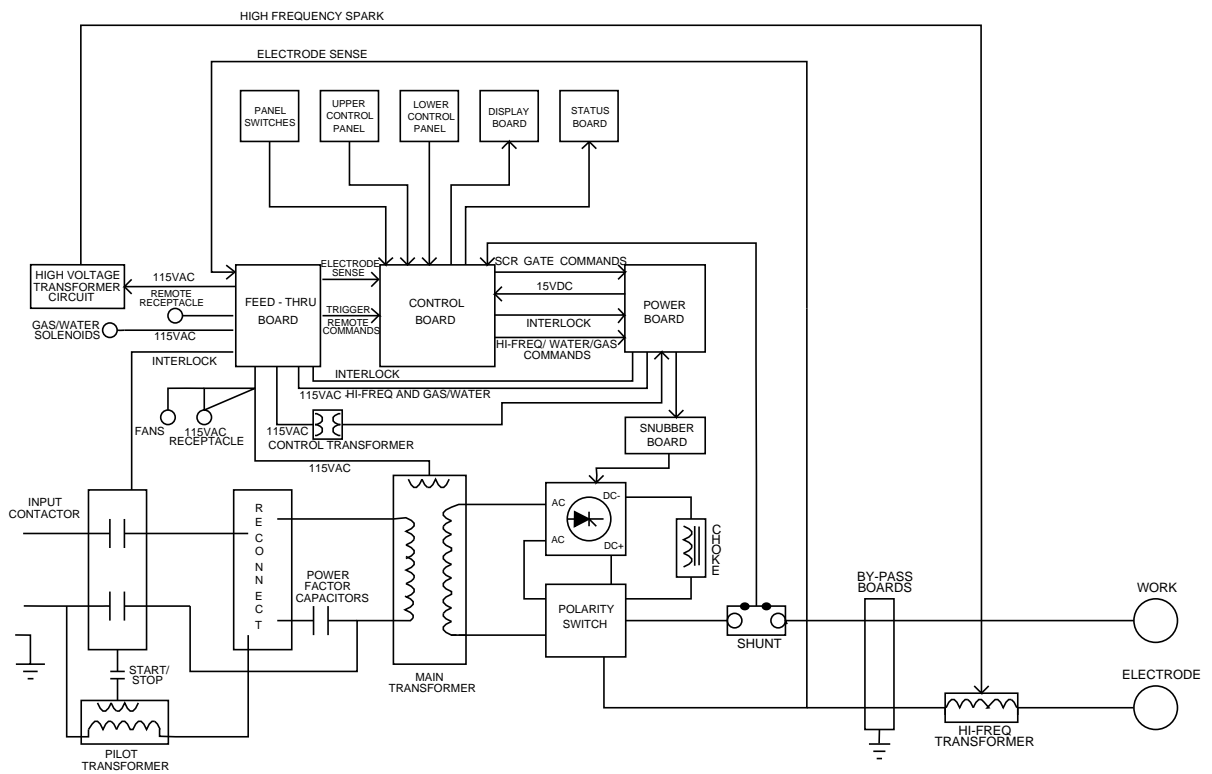

THEORY OF OPERATION

FIGURE E.2 – INPUT VOLTAGE, CONTACTOR, RECONNECT PANEL, PILOT TRANSFORMER, CONTROL TRANSFORMER, POWER FACTOR CAPACITORS AND MAIN TRANSFORMER

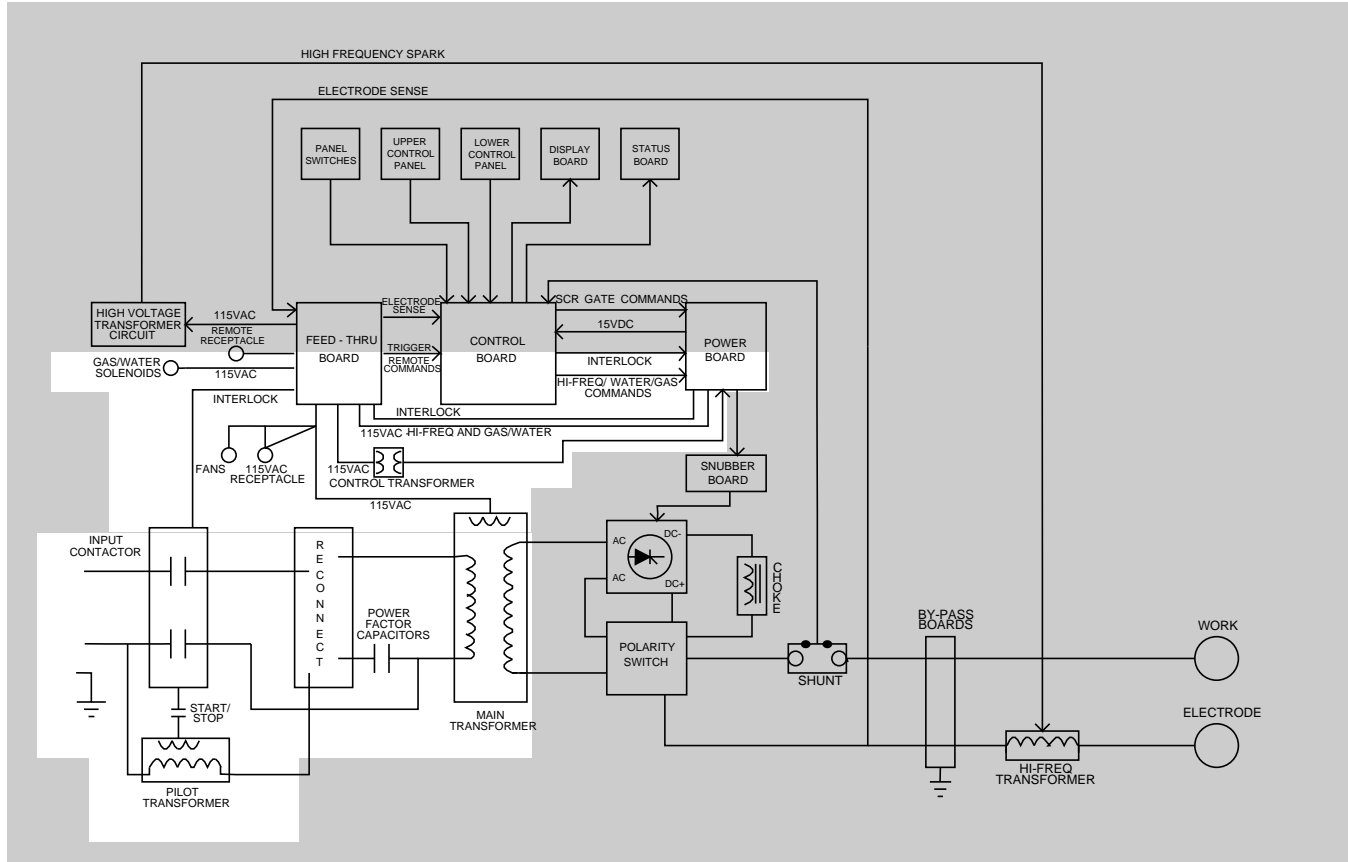

GENERAL DESCRIPTION

The Square Wave TIG 355 is a constant current, single range square wave AC/DC TIG (GTAW) arc welding power source with built-in high frequency stabilization. It also has stick (SMAW) capability. The Square Wave TIG 355 gives the operator full control of the welding current plus the ability to preset weld and start currents. Preweld and postflow timers are included for shielding gas and cooling water control. Altogether the many features of the machine allow part or all of a weld cycle to be preset or "programmed," which simplifies the TIG welding process.

INPUT POWER CIRCUIT

The desired single-phase input power is connected to the TIG 355 through an input contactor located in the rear of the machine. The input power is also connected directly to the pilot transformer, which supplies 115VAC for the input contactor interlock and start/stop circuits.

A reconnect panel allows the user to configure the pilot transformer, the power factor capacitors, and the main transformer for the desired input voltage. This AC input voltage is applied, through the input contactor, to the primary of the main transformer. The power factor correction capacitors are incorporated in the primary circuit of the main transformer to help balance the inductive nature of the TIG 355. The main transformer changes the high voltage, low current input power to a low voltage, high current output.

In addition, the main transformer also has an isolated 115VAC auxiliary winding that supplies power to operate the cooling fans and offers 15 amps of auxiliary power at the 115VAC receptacle. This 115VAC is also applied, through the feed-thru board, to the power board for high voltage and gas/water solenoid operation.

The control transformer primary is also powered by the 115VAC winding in the main transformer. The secondary voltages that are developed in the control transformer supply power to the control and power boards.

NOTE: Unshaded areas of Block Logic Diagram are the subject of discussion.

FIGURE E.3 – OUTPUT RECTIFICATION AND FEEDBACK CONTROL

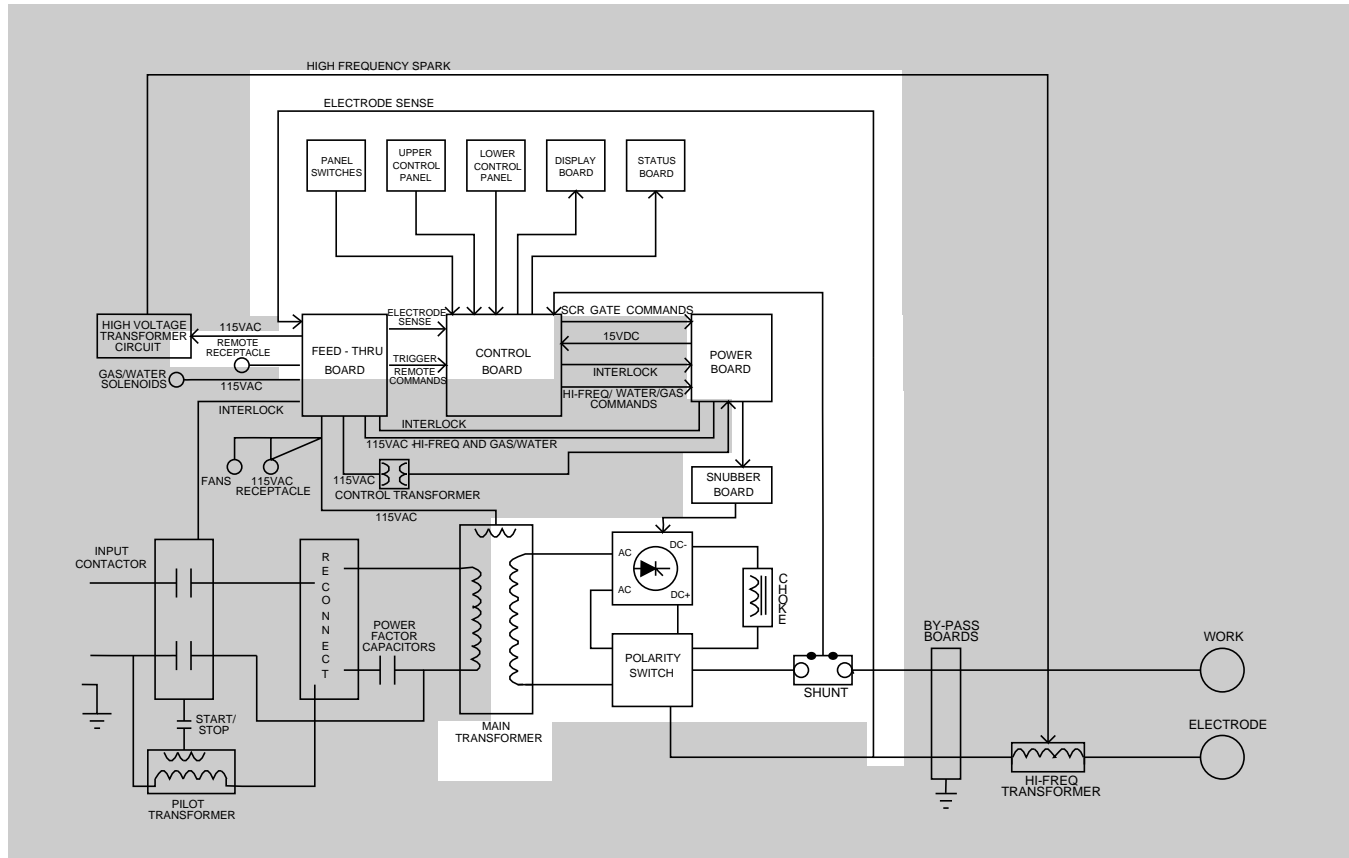

OUTPUT RECTIFICATION AND FEEDBACK CONTROL

The AC output from the main transformer secondary is rectified and controlled through the SCR bridge. Output current is sensed at the shunt as a low voltage signal and fed back to the control board. The control board compares the commands of the control panels, panel switches, and/or remote control with the shunt feedback signal and electrode sense lead. The appropriate SCR gate firing commands are created by the control board and sent to the power board where the gate firing pulses are generated and applied through the snubber board to the SCR bridge. The control board controls the firing of the SCRs, which controls the output of the machine. See SCR Operation. The control board also powers and commands the display board and the status board.

The electrode sense, the remote control and the trigger signals are applied through the feed – thru board to the control board.

NOTE: Unshaded areas of Block Logic Diagram are the subject of discussion.

THEORY OF OPERATION

FIGURE E.4 – HIGH VOLTAGE/HIGH FREQUENCY CIRCUIT

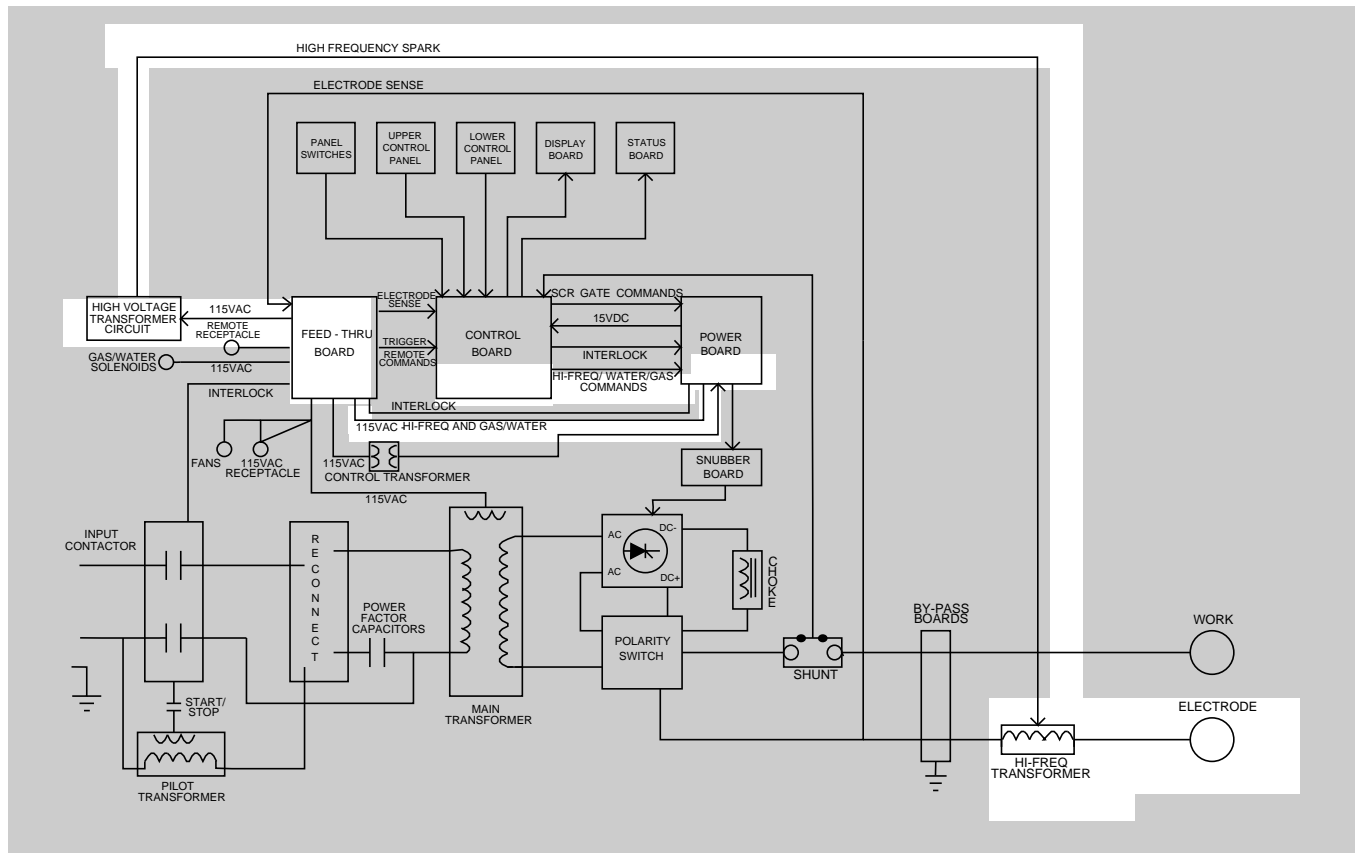

HIGH VOLTAGE/ HIGH FREQUENCY CIRCUIT

The control board signals the power board to pass the 115VAC voltage through the feed – thru board to the primary of the high voltage transformer. The secondary of the high voltage transformer is coupled to a spark gap generator and also to the high frequency transformer. The high frequency transformer transfers the high frequency “spark” to the electrode terminal.

NOTE: Unshaded areas of Block Logic Diagram are the subject of discussion.

THEORY OF OPERATION

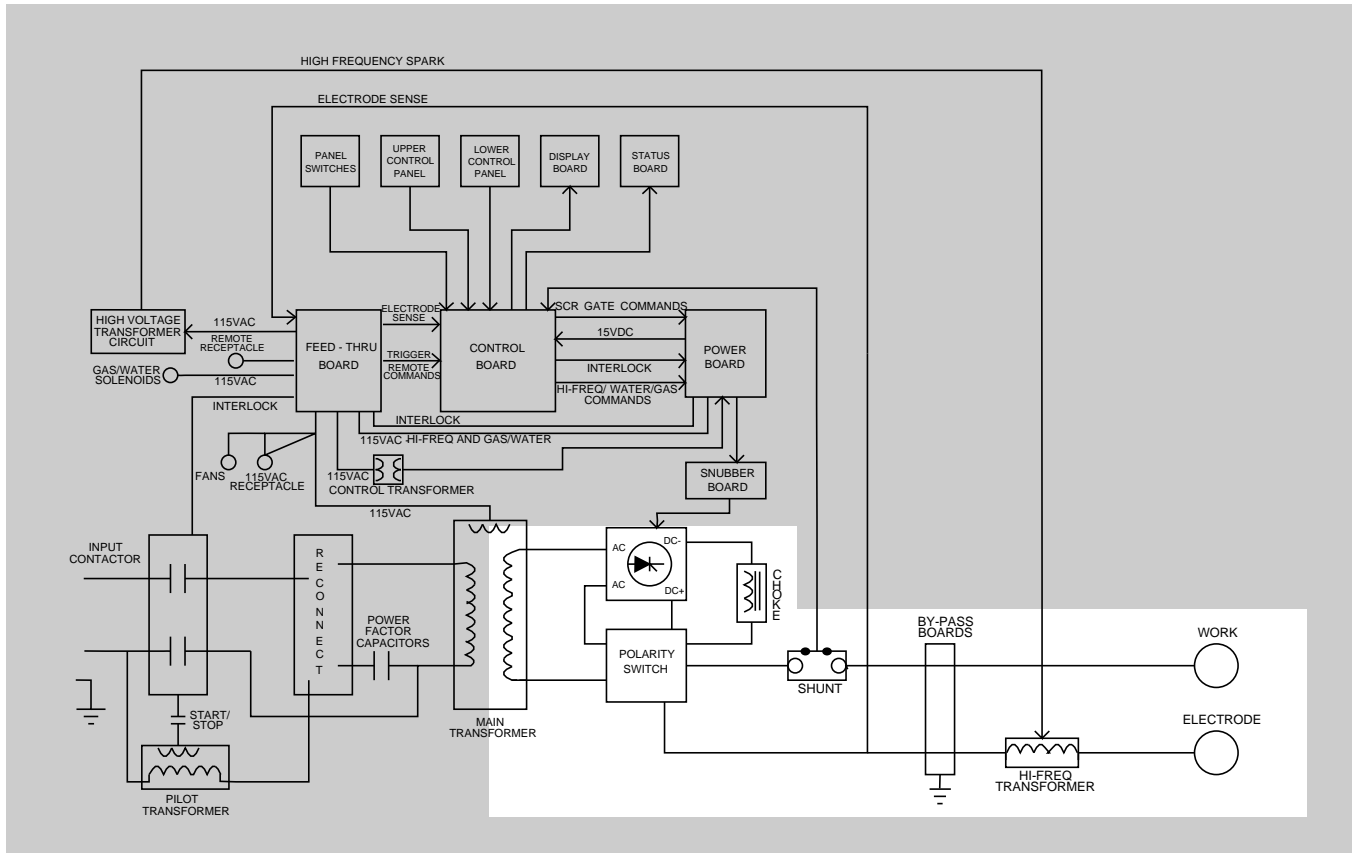
FIGURE E.5 - DC WELDING OUTPUT CIRCUIT

DC WELDING OUTPUT

When the polarity switch is placed in either DC position, the AC voltage from the main transformer secondary is applied to the SCR bridge. The SCR bridge and choke circuits are connected in a conventional full wave bridge and filter configuration, resulting in a controlled DC output. Since the choke is in series with the negative leg of the bridge and also in series with the welding load, a filtered DC is applied to the machine output terminals.

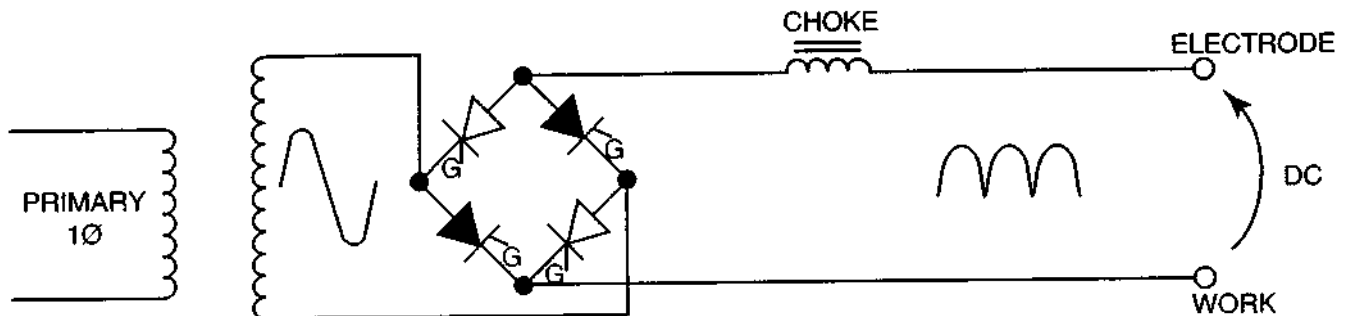
FIGURE E.5a - SCR BRIDGE AND CHOKE CONFIGURATION FOR DC WELDING

NOTE: Unshaded areas of Block Logic Diagram are the subject of discussion.

SQUARE WAVE TIG 355
LINCOLN ELECTRIC

THEORY OF OPERATION

FIGURE E.6 – AC WELDING OUTPUT CIRCUIT

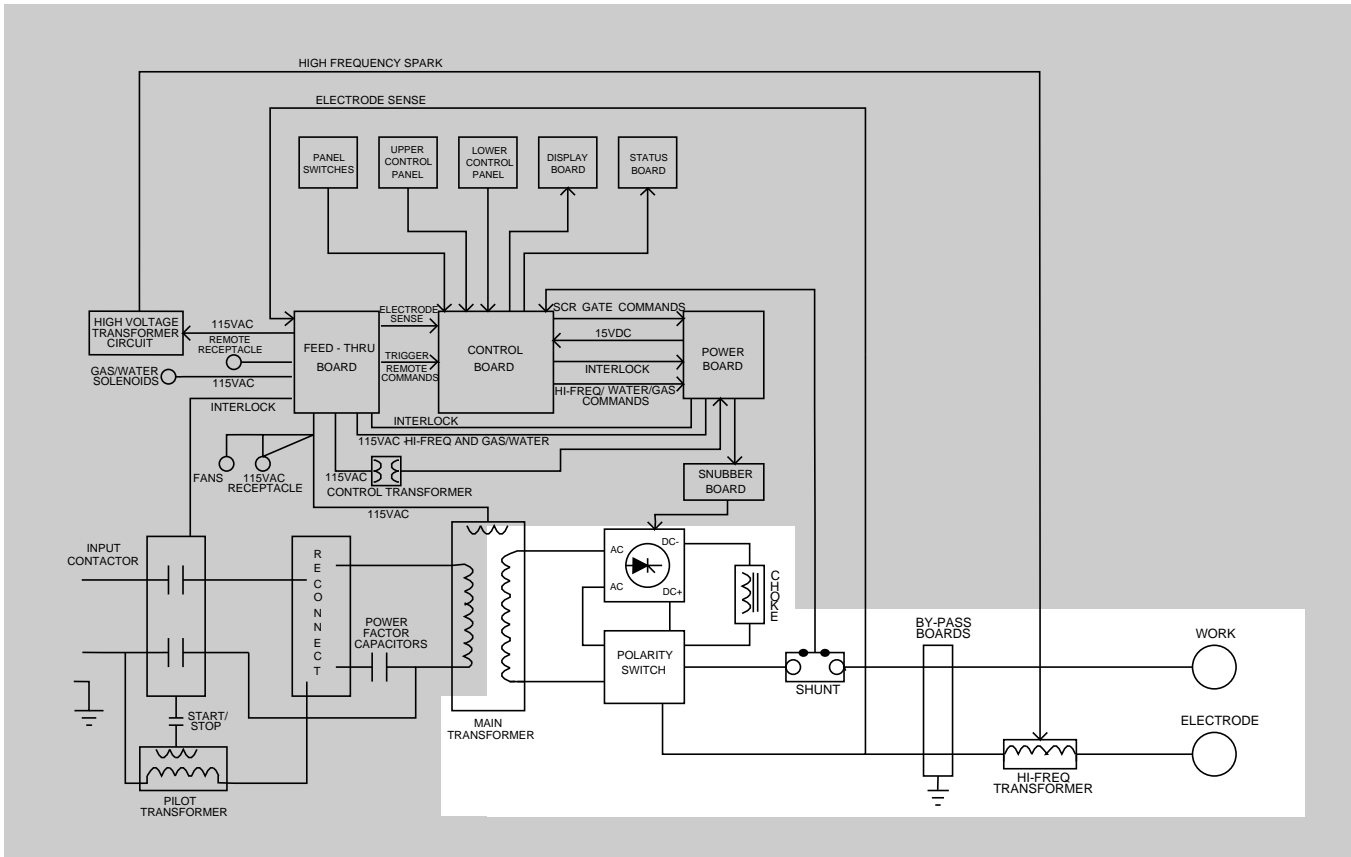

AC WELDING OUTPUT

Rotating the polarity switch to the AC position changes the welding power circuit. One lead (X2) of the main transformer secondary is connected to the machine output work terminal. The other secondary lead (X1) is connected to one of the AC connections on the SCR bridge. The electrode terminal is con-

nected to the other AC side of the bridge. The choke is now electrically across the negative and positive SCR bridge connections. With the ability of the choke to store energy and the SCRs to turn on at the appropriate times, an AC square wave is developed and applied to the output terminals.

FIGURE E.6a – SCR BRIDGE AND CHOKE CONFIGURATION FOR AC WELDING

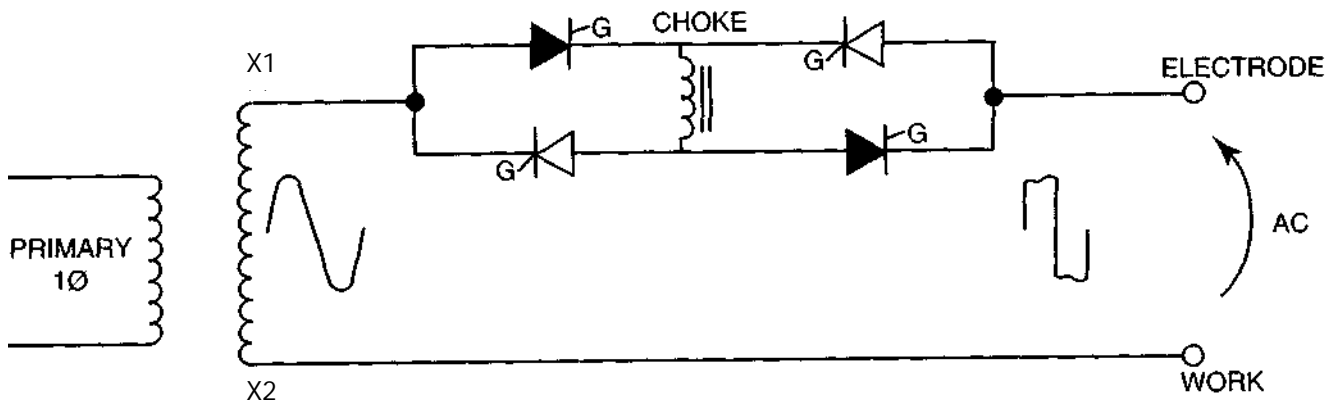

NOTE: Unshaded areas of Block Logic Diagram are the subject of discussion.

Return to Section TOC | Return to Master TOC

FIGURE E.7 - SCR OPERATION

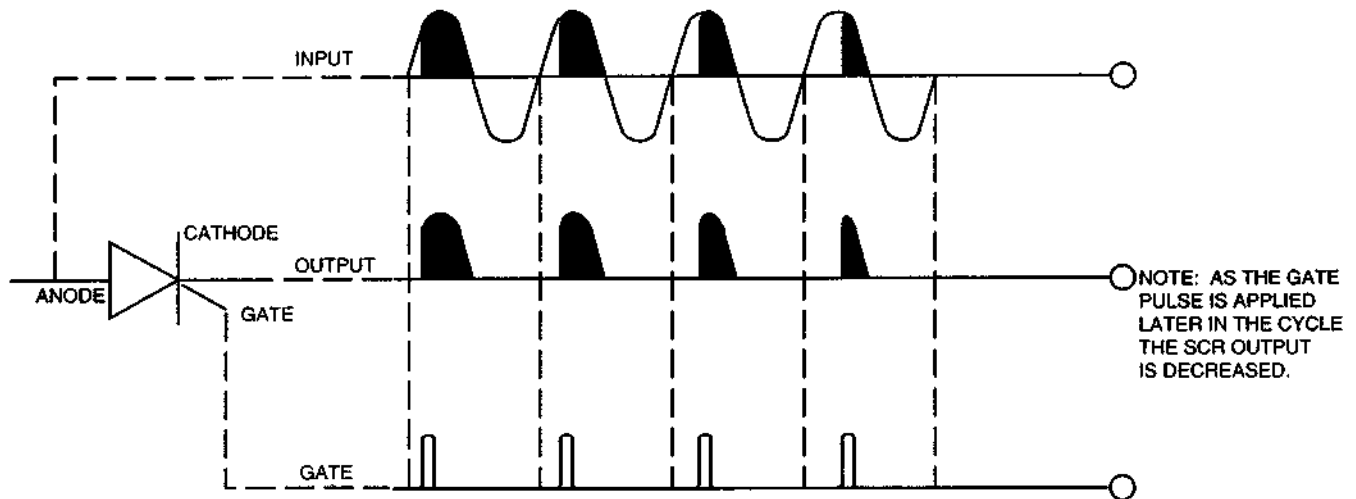

SCR OPERATION

A silicon controlled rectifier (SCR) is a three-terminal device used to control rather large currents to a load. An SCR acts very much like a switch. When a gate signal is applied to the SCR, it is turned ON and there is current flow from anode to cathode. In the ON state the SCR acts like a closed switch. When the SCR is turned OFF, there is no current flow from anode to cathode; thus the device acts like an open switch. As the name suggests, the SCR is a rectifier, so it passes current only during positive half cycles of the AC supply. The positive half cycle is the portion of the sine wave in which the anode of the SCR is more positive than the cathode.

When an AC supply voltage is applied to the SCR, the device spends a certain portion of the AC cycle time in the ON state and the remainder of the time in the OFF state. The amount of time spent in the ON state is controlled by the gate.

An SCR is fired by a short burst of current into the gate. This gate pulse must be more positive than the cathode voltage. Since there is a standard PN junction between gate and cathode, the voltage between these terminals must be slightly greater than 0.6V. Once the SCR has fired it is not necessary to continue the flow of gate current. As long as current continues to flow from anode to cathode, the SCR will remain ON. When the anode to cathode current drops below a minimum value, called holding current, the SCR will shut OFF. This normally occurs as the AC supply voltage passes through zero into the negative portion of the sine wave. If the SCR is turned ON early in the positive half cycle, the conduction time is longer, resulting in greater SCR output. If the gate firing occurs later in the cycle, the conduction time is less, resulting in lower SCR output.

NOTE: Unshaded areas of Block Logic Diagram are the subject of discussion.

PROTECTIVE CIRCUITS

Protective circuits are designed into the Square Wave TIG 355 to sense trouble and shut down the machine before the trouble damages the internal machine components. Both thermal protection and current overload are included.

THERMAL PROTECTION

Thermostats protect the machine from excessive operating temperatures. Excessive operating temperatures may be caused by a lack of cooling air or by operating the machine beyond the duty cycle and output rating. If excessive operating temperature should occur, causing the secondary thermostat to open, the input contactor will shut the machine off. If the primary thermostat opens, the machine will stay on (pilot light, meters and fans running), but output current will be limited to no more than 5 amps.

Once the machine cools sufficiently the thermostats are self-resetting. If the thermostat shutdown is caused by excessive output or duty cycle and the fan is operating normally, the power may be left on, and the reset should occur within a 15 minute period. If the fan is not functioning properly or the air intake louvers are obstructed, then the input power must be removed and the fan problem or air obstruction corrected.

OVERLOAD PROTECTION

The machine is electronically protected from producing excessively high output currents. Should the output current exceed approximately 400 amps, an electronic circuit will reduce and limit the output current. The machine will continue to limit the output current until the overload is removed.

TABLE OF CONTENTS

-TROUBLESHOOTING & REPAIR SECTION-

Troubleshooting & Repair Section.....	Section F
How to Use Troubleshooting Guide.....	F-2
PC Board Troubleshooting Procedures and Replacement.....	F-3
Troubleshooting Guide	F-4
Test Procedures	F-20
Input Power Factor Capacitor Voltage Check and Discharge Procedure.....	F-20
ARC Start Trigger Circuit Test.....	F-22
Power Board Test	F-25
Input Contactor Test.....	F-28
Pilot Transformer Test.....	F-32
Feed-Thru PC Board Test.....	F-34
Protection PC Board Test.....	F-38
Main Transformer Test	F-41
Control Transformer (T5) Voltage Test	F-44
Control Board Test.....	F-47
Static SCR Test.....	F-51
Active SCR Test	F-54
Oscilloscope Waveforms	F-58
Normal Open Circuit Voltage Waveform (DC Stick Mode).....	F-58
Normal Open Circuit Voltage Waveform (AC Stick Mode)	F-59
Normal Open Circuit Voltage Waveform (DC TIG Mode)	F-60
Normal Open Circuit Voltage Waveform (AC TIG Mode).....	F-61
Typical Output Voltage Waveform – Machine Loaded (DC TIG Mode)	F-62
AC TIG Mode (Balanced Waveform)	F-63
Abnormal Open Circuit Voltage – (DC TIG Mode, One Output SCR Not Functioning).....	F-64
Abnormal Open Circuit Voltage – (AC TIG Mode, One Output SCR Not Functioning).....	F-65
Replacement Procedures.....	F-66
Control PC Board Removal and Replacement.....	F-66
Power PC Board Removal and Replacement	F-68
Input Contactor (C1) Removal and Replacement	F-70
Fan Motor and Blade Removal and Replacement	F-73
Output Rectifier Removal and Replacement.....	F-75
SCR Removal and Replacement	F-78
Rest after Repair	F-84

TROUBLESHOOTING & REPAIR

HOW TO USE TROUBLESHOOTING GUIDE

⚠ WARNING

Service and repair should be performed by only Lincoln Electric Factory Trained Personnel. Unauthorized repairs performed on this equipment may result in danger to the technician and machine operator and will invalidate your factory warranty. For your safety and to avoid Electrical Shock, please observe all safety notes and precautions detailed throughout this manual.

This Troubleshooting Guide is provided to help you locate and repair possible machine malfunctions. Simply follow the three-step procedure listed below.

Step 1. LOCATE PROBLEM (SYMPTOM). Look under the column labeled "PROBLEM (SYMPTOMS)". This column describes possible symptoms that the machine may exhibit. Find the listing that best describes the symptom that the machine is exhibiting. Symptoms are grouped into three main categories: Output Problems, Function Problems, and Welding Problems.

Step 2. PERFORM EXTERNAL TESTS. The second column, labeled "POSSIBLE AREAS OF MISADJUSTMENT(S)," lists the obvious external possibilities that may contribute to the machine symptom. Perform these tests/checks in the order listed. In general, these tests can be conducted without removing the case wrap-around cover.

Step 3. PERFORM COMPONENT TESTS. The last column, labeled "Recommended Course of Action," lists the most likely components that may have failed in your machine. It also specifies the appropriate test procedure to verify that the subject component is either good or bad. If there are a number of possible components, check the components in the order listed to eliminate one possibility at a time until you locate the cause of your problem.

All of the referenced test procedures referred to in the Troubleshooting Guide are described in detail at the end of this chapter. Refer to the Troubleshooting and Repair Table of Contents to locate each specific Test Procedure. All of the referred to test points, components, terminal strips, etc., can be found on the referenced electrical wiring diagrams and schematics. Refer to the Electrical Diagrams Section Table of Contents to locate the appropriate diagram.

⚠ CAUTION

If for any reason you do not understand the test procedures or are unable to perform the test/repairs safely, contact the Lincoln Electric Service Department for electrical troubleshooting assistance before you proceed. Call 216-383-2531 or 1-800-833-9353.

PC BOARD TROUBLESHOOTING PROCEDURES AND REPLACEMENT

⚠ WARNING**ELECTRIC SHOCK can kill.**

Have an electrician install and service this equipment. Turn the machine OFF before working on equipment. Do not touch electrically hot parts.

Sometimes machine failures appear to be due to PC board failures. These problems can sometimes be traced to poor electrical connections. To avoid problems when troubleshooting and replacing PC boards, please use the following procedure:

1. Determine to the best of your technical ability that the PC board is the most likely component causing the failure symptom.
2. Check for loose connections at the PC board to assure that the PC board is properly connected.
3. If the problem persists, replace the suspect PC board using standard practices to avoid static electrical damage and electrical shock. Read the warning inside the static resistant bag and perform the following procedures.



ATTENTION
Static-Sensitive
Devices
Handle only at
Static-Safe
Workstations

Resuable
Container
Do Not Destroy

PC Board can be damaged by static electricity.

- Remove your body's static charge before opening the static-shielding bag. Wear an anti-static wrist strap. For safety, use a 1 Meg ohm resistive cord connected to a grounded part of the equipment frame.
 - If you don't have a wrist strap, touch an unpainted, grounded part of the equipment frame. Keep touching the frame to prevent static build-up. Be sure not to touch any electrically live parts at the same time.
- Tools which come in contact with the PC Board must be either conductive, anti-static or static-dissipative.

- Remove the PC Board from the static-shielding bag and place it directly into the equipment. Don't set the PC Board on or near paper, plastic or cloth which could have a static charge. If the PC Board can't be installed immediately, put it back in the static-shielding bag.
 - If the PC Board uses protective shorting jumpers, don't remove them until installation is complete.
 - If you return a PC Board to The Lincoln Electric Company for credit, it must be in the static-shielding bag. This will prevent further damage and allow proper failure analysis.
4. Test the machine to determine if the failure symptom has been corrected by the replacement PC board.

NOTE: Allow the machine to heat up so that all electrical components can reach their operating temperature.

5. Remove the replacement PC board and substitute it with the original PC board to recreate the original problem.
 - a. If the original problem does not reappear by substituting the original board, then the PC board was not the problem. Continue to look for bad connections in the control wiring harness, junction blocks, and terminal strips.
 - b. If the original problem is recreated by the substitution of the original board, then the PC board was the problem. Reinstall the replacement PC board and test the machine.
6. Always indicate that this procedure was followed when warranty reports are to be submitted.

NOTE: Following this procedure and writing on the warranty report, "INSTALLED AND SWITCHED PC BOARDS TO VERIFY PROBLEM," will help avoid denial of legitimate PC board warranty claims.

TROUBLESHOOTING & REPAIR

TROUBLESHOOTING GUIDE

Observe Safety Guidelines detailed in the beginning of this manual.

PROBLEMS (SYMPTOMS)	POSSIBLE AREAS OF MISADJUSTMENT(S)	RECOMMENDED COURSE OF ACTION
OUTPUT PROBLEMS		
Major physical or electrical damage is evident when the sheet metal cover(s) are removed.	<ol style="list-style-type: none"> Contact your local authorized Lincoln Electric Field Service Facility for technical assistance. 	<ol style="list-style-type: none"> Contact the Lincoln Electric Service Department, 216-383-2531 or 1-800-833-9353 (WELD).
Machine is dead – no output – no fans – no displays.	<ol style="list-style-type: none"> Check the input voltage at the machine. Input voltage must match the rating plate and the reconnect panel. Check for blown or missing fuses in the input lines. Check for a blown or missing control circuit fuse F1. The machine secondary thermostat may be open. Allow machine to cool. 	<ol style="list-style-type: none"> If when the “start” button is pushed the pilot light is lit and the input contactor (CR1) activates, check the wiring at the reconnect panel and also to the main transformer primary coils. Perform the Input Contactor Test. Perform the Main Transformer Test. If when the “start” button is pushed the pilot light does NOT light and the input contactor does NOT activate, check the start/stop button for proper operation. Perform the Pilot Transformer Test. If when the “start” button is pushed the pilot light is lit and the input contactor does NOT activate, perform the Input Contactor Test.

⚠ **CAUTION**

If for any reason you do not understand the test procedures or are unable to perform the test/repairs safely, contact the Lincoln Electric Service Department for electrical troubleshooting assistance before you proceed. Call 216-383-2531 or 1-800-833-9353.



Return to Section TOC
Return to Master TOC
Return to Section TOC
Return to Master TOC
Return to Section TOC
Return to Master TOC
Return to Section TOC
Return to Master TOC

TROUBLESHOOTING & REPAIR

TROUBLESHOOTING GUIDE

Observe Safety Guidelines detailed in the beginning of this manual.

PROBLEMS (SYMPTOMS)	POSSIBLE AREAS OF MISADJUSTMENT(S)	RECOMMENDED COURSE OF ACTION
OUTPUT PROBLEMS		
<p>The input contactor activates when "start" button is pushed but will NOT stay closed. Machine shuts off when "start" button is released.</p>	<ol style="list-style-type: none"> 1. Check the input voltage at the machine. Input voltage must match the rating plate and the reconnect panel. 2. Blown or missing control circuit fuse (F1). 	<ol style="list-style-type: none"> 1. Perform the <i>Input Contactor Test.</i> 2. Perform the <i>Control Transformer Test.</i> 3. Perform the <i>Feed - Thru PC Board Test.</i> 4. Perform the <i>Control Board Interlock Test.</i> 5. The power board may be faulty. Replace.
<p>The machine shuts off and the control fuse (F1) repeatedly fails.</p>	<ol style="list-style-type: none"> 1. Check the input voltage at the machine. Input voltage must match the rating plate and the reconnect panel. 2. Make sure the fuse is the correct rating (1/2 amp). 3. The input voltage may be too high (more than 10% over rated). 	<ol style="list-style-type: none"> 1. Perform the <i>Control Transformer Test.</i> 2. Perform the <i>Power Board Test.</i> 3. The control board may be faulty. Replace.

⚠ **CAUTION**

If for any reason you do not understand the test procedures or are unable to perform the test/repairs safely, contact the Lincoln Electric Service Department for electrical troubleshooting assistance before you proceed. Call 216-383-2531 or 1-800-833-9353.

Return to Section TOC
Return to Master TOC

TROUBLESHOOTING & REPAIR

TROUBLESHOOTING GUIDE

Observe Safety Guidelines detailed in the beginning of this manual.

PROBLEMS (SYMPTOMS)	POSSIBLE AREAS OF MISADJUSTMENT(S)	RECOMMENDED COURSE OF ACTION
OUTPUT PROBLEMS		
<p>Fans and display are functional. No output from machine in either Stick or TIG modes.</p>	<ol style="list-style-type: none"> 1. The primary thermostat may be open. Allow machine to cool. 2. If the machine is in Remote control mode, make sure a Lincoln remote control device is connected to the amphenol. 3. If the machine works properly in the Local control mode, check or replace the remote control device. 	<ol style="list-style-type: none"> 1. If the machine works properly in Local control mode but not in Remote control, then perform the Protection Board Test. 2. If the machine does NOT have output in either mode, Local or Remote, check the primary thermostat for proper operation. It is normally closed. 3. Perform the Arc Start Trigger Circuit Test. 4. Perform the SCR Bridge Test. 5. Perform the Control Transformer Test. 6. Perform the Power Board Test. 7. The control board may be faulty. Replace.

⚠ CAUTION

If for any reason you do not understand the test procedures or are unable to perform the test/repairs safely, contact the Lincoln Electric Service Department for electrical troubleshooting assistance before you proceed. Call 216-383-2531 or 1-800-833-9353.



Return to Section TOC
Return to Master TOC

TROUBLESHOOTING & REPAIR

TROUBLESHOOTING GUIDE

Observe Safety Guidelines detailed in the beginning of this manual.

PROBLEMS (SYMPTOMS)	POSSIBLE AREAS OF MISADJUSTMENT(S)	RECOMMENDED COURSE OF ACTION
OUTPUT PROBLEMS		
<p>The machine shuts off (pilot light goes out and the fans stop) when the Arc Start Switch or Amptrol is activated.</p>	<ol style="list-style-type: none"> The input voltage may be too high (more than 10% over rated). The Arc Start switch may be faulty. Check or replace. 	<ol style="list-style-type: none"> Perform the SCR Bridge Test. Perform the Power Board Test. Perform the Control Board Test. Shunt may be faulty or overheated. Check for loose connections and replace shunt if necessary.
<p>The 115VAC receptacle does not work. The machine operates normally.</p>	<ol style="list-style-type: none"> The circuit breaker CB1 may have opened. Reset if necessary. Check for the presence of 115VAC at the receptacle. 	<ol style="list-style-type: none"> The circuit breaker may be faulty. Test or replace. If the fans are running, check the receptacle and the associated wiring.

⚠ CAUTION

If for any reason you do not understand the test procedures or are unable to perform the test/repairs safely, contact the Lincoln Electric Service Department for electrical troubleshooting assistance before you proceed. Call 216-383-2531 or 1-800-833-9353.



Return to Section TOC
Return to Master TOC

TROUBLESHOOTING & REPAIR

TROUBLESHOOTING GUIDE

Observe Safety Guidelines detailed in the beginning of this manual.

PROBLEMS (SYMPTOMS)	POSSIBLE AREAS OF MISADJUSTMENT(S)	RECOMMENDED COURSE OF ACTION
FUNCTION PROBLEMS		
Digital display does not light. Machine turns on and operates normally.	1. Contact your local authorized Lincoln Electric Field Service Facility.	1. Check for 5VDC from 2J7+ to 4J7- on the display board. If the voltage is present and the display does NOT light, the display board may be faulty. Replace. 2. The control board may be faulty. Replace.
The display lights but a current cannot be preset.	1. Contact your local authorized Lincoln Electric Field Service Facility.	1. Set the Peak Current control (R10) to the 12 o'clock position. Position the Start Current switch (S13) to the off position. The machine should weld at approximately 80 amps. If the machine welds properly but does NOT display the actual welding current, the meter board may be defective. Replace. 1a. The control board may be defective. Replace. 2. If the machine does NOT weld properly, check or replace the Peak Current control potentiometer (R10). 2a. The control board may be faulty. Replace.

CAUTION

If for any reason you do not understand the test procedures or are unable to perform the test/repairs safely, contact the Lincoln Electric Service Department for electrical troubleshooting assistance before you proceed. Call 216-383-2531 or 1-800-833-9353.

SQUARE WAVE TIG 355



TROUBLESHOOTING & REPAIR

TROUBLESHOOTING GUIDE

Observe Safety Guidelines detailed in the beginning of this manual.

PROBLEMS (SYMPTOMS)	POSSIBLE AREAS OF MISADJUSTMENT(S)	RECOMMENDED COURSE OF ACTION
FUNCTION PROBLEMS		
1. In Stick mode the machine welds at a very low output, regardless of the peak current control setting.	1. If the machine is in the Remote control mode, make sure a Lincoln remote control device is connected to the amphenol. 2. The Start Current may be set too low for the electrode size being used. 3. If the machine works properly in Local control mode, check or replace the remote control device. 4. If the machine works properly in TIG mode, contact your local authorized Lincoln Electric Field Service Facility.	1. If the machine works properly in Local control mode but not in Remote mode, perform the Protection Board Test . 2. If the machine operates properly in TIG mode but not in Stick mode, the control board may be faulty. Replace. 3. If the output is low in all modes, perform the SCR Bridge Test . 4. The power board may be faulty. Replace. 5. The control board may be faulty. Replace.

⚠ CAUTION

If for any reason you do not understand the test procedures or are unable to perform the test/repairs safely, contact the Lincoln Electric Service Department for electrical troubleshooting assistance before you proceed. Call 216-383-2531 or 1-800-833-9353.



Return to Section TOC
Return to Master TOC

TROUBLESHOOTING & REPAIR

TROUBLESHOOTING GUIDE

Observe Safety Guidelines detailed in the beginning of this manual.

PROBLEMS (SYMPTOMS)	POSSIBLE AREAS OF MISADJUSTMENT(S)	RECOMMENDED COURSE OF ACTION
FUNCTION PROBLEMS		
<p>The machine welds at very high outputs, regardless of the Peak Current control setting.</p>	<ol style="list-style-type: none"> 1. Make sure the start controls are set correctly for the process being used. 2. If the machine is in Remote control mode, change modes to Local control. If the problem is resolved, the remote control unit may be defective. 	<ol style="list-style-type: none"> 1. Perform the SCR Bridge Test. 2. The power board may be faulty. Replace. 3. The control board may be faulty. Replace.
<p>The Arc Force control has no effect on the arc.</p>	<ol style="list-style-type: none"> 1. The Arc Force control is active only in the Stick mode. 2. The effect of the Arc Force control will be less noticeable at high welding currents. Weld at low currents (less than 150 amps) and check the Arc Force control function. 	<ol style="list-style-type: none"> 1. Check the Arc Force control potentiometer for correct resistance and proper operation. 2. Check the continuity of leads #441 and #445. See Wiring Diagram. 3. The control board may be faulty. Replace.

⚠ CAUTION

If for any reason you do not understand the test procedures or are unable to perform the test/repairs safely, contact the Lincoln Electric Service Department for electrical troubleshooting assistance before you proceed. Call 216-383-2531 or 1-800-833-9353.



Return to Section TOC
Return to Master TOC

TROUBLESHOOTING & REPAIR

TROUBLESHOOTING GUIDE

Observe Safety Guidelines detailed in the beginning of this manual.

PROBLEMS (SYMPTOMS)	POSSIBLE AREAS OF MISADJUSTMENT(S)	RECOMMENDED COURSE OF ACTION
TIG MODE PROBLEMS		
Gas and/or water do not flow, even though the gas and/or water LEDs are lit.	<ol style="list-style-type: none"> 1. The machine must be in TIG mode. The gas, water and high frequency circuits do NOT function in Stick mode. 2. Check the gas and/or water supplies for adequate pressure or kinked or broken hoses. 	<ol style="list-style-type: none"> 1. Check for proper operation of the gas and/or water solenoids. 2. If 115VAC is applied to the solenoids, they should activate and allow gas or water to flow. 3. If 115VAC is applied to the solenoids and they do NOT activate, the solenoids may be faulty. Replace. 4. Perform the Control Board Test.

⚠ CAUTION

If for any reason you do not understand the test procedures or are unable to perform the test/repairs safely, contact the Lincoln Electric Service Department for electrical troubleshooting assistance before you proceed. Call 216-383-2531 or 1-800-833-9353.



Return to Section TOC

Return to Master TOC

TROUBLESHOOTING & REPAIR

TROUBLESHOOTING GUIDE

Observe Safety Guidelines detailed in the beginning of this manual.

PROBLEMS (SYMPTOMS)	POSSIBLE AREAS OF MISADJUSTMENT(S)	RECOMMENDED COURSE OF ACTION
TIG MODE PROBLEMS		
<p>No high frequency. Machine is in TIG Mode and has normal output.</p>	<ol style="list-style-type: none"> 1. In order for the high frequency to operate, the machine must be either in Start Only mode or Continuous High Frequency mode. 2. The high frequency spark gap may be too large or shorted. Check the gap per maintenance instructions. 	<ol style="list-style-type: none"> 1. Check the high voltage transformer (T3). The normal resistance of the secondary winding is 12.5 k-ohms. 115VAC is applied to the primary of T3. A very high voltage is developed on the secondary winding. For assistance call the Lincoln Electric Service Dept., (216) 383-2531 or 1-800-833-9353 (WELD). 2. Check the values of R6 and C6. Replace if necessary. 3. Check the continuity of coils L4 and L5. Normal resistance is approximately 10 ohms. 4. Perform the Feed - Thru Board Test. 5. Perform the Control Board High Frequency Signal Test. 6. The power board may be faulty. Replace.

⚠ CAUTION

If for any reason you do not understand the test procedures or are unable to perform the test/repairs safely, contact the Lincoln Electric Service Department for electrical troubleshooting assistance before you proceed. Call 216-383-2531 or 1-800-833-9353.



Return to Section TOC
Return to Master TOC

TROUBLESHOOTING & REPAIR

TROUBLESHOOTING GUIDE

Observe Safety Guidelines detailed in the beginning of this manual.

PROBLEMS (SYMPTOMS)	POSSIBLE AREAS OF MISADJUSTMENT(S)	RECOMMENDED COURSE OF ACTION
TIG MODE PROBLEMS		
Weak high frequency – machine has normal welding output.	<ol style="list-style-type: none"> 1. The spark gap may be misadjusted. Check and reset per maintenance instructions. 2. Improper shielding gas flow. Adjust for a flow of 10 to 30 CFH (4.7 to 14.1 l/min.) for most applications. 3. Work and electrode cables may be in poor condition, allowing the high frequency to “leak off.” Use good quality cables with a high natural rubber content, such as Lincoln Stable Arc Cable. Cables should be as short as possible. 	<ol style="list-style-type: none"> 1. Make sure that 115VAC is being applied to the primary of the high voltage transformer (T3). See Wiring Diagram. 2. Check for an open or arcing high frequency component. Replace as required. (Examples: R6, C6, C3, R4) 3. If spark is weak at the spark gap, check or replace the high frequency circuit. (Examples: T3, L4, L5).
Lack of penetration in AC TIG welding.	<ol style="list-style-type: none"> 1. The AC Wave Balance control may be set improperly – settings above 3 give increased penetration. 	<ol style="list-style-type: none"> 1. Check the AC Wave Balance control potentiometer (R12) for correct resistance and proper operation. See Wiring Diagram. 2. Check leads #443 and #444 for continuity from the AC Wave Balance control potentiometer to the lower control panel. See Wiring Diagram. 3. Perform the SCR Rectifier Bridge Tests. 4. The control board may be faulty. Replace.

⚠ CAUTION

If for any reason you do not understand the test procedures or are unable to perform the test/repairs safely, contact the Lincoln Electric Service Department for electrical troubleshooting assistance before you proceed. Call 216-383-2531 or 1-800-833-9353.



Return to Section TOC

Return to Master TOC

TROUBLESHOOTING & REPAIR

TROUBLESHOOTING GUIDE

Observe Safety Guidelines detailed in the beginning of this manual.

PROBLEMS (SYMPTOMS)	POSSIBLE AREAS OF MISADJUSTMENT(S)	RECOMMENDED COURSE OF ACTION
TIG MODE PROBLEMS		
Black areas along weld bead.	<ol style="list-style-type: none"> 1. The tungsten electrode may be contaminated. Replace or sharpen. 2. Shielding gas flow may be insufficient. 3. Contaminated gas or faulty gas line or torch. 	<ol style="list-style-type: none"> 1. This may be a welding procedure problem. <p>Contact The Lincoln Electric Service Department, (216) 383-2531 or 1-800-833-9353 (WELD).</p>
Black areas along weld bead at or near end of weld.	<ol style="list-style-type: none"> 1. Increase the gas post flow time. 	<ol style="list-style-type: none"> 1. This may be a welding procedure problem. <p>Contact The Lincoln Electric Service Department, (216) 383-2531 or 1-800-833-9353 (WELD).</p>
The machine has low output when in TIG 4-Step mode.	<ol style="list-style-type: none"> 1. The machine must be in Local control mode when 4-Step is used. 2. The machine output control may be set incorrectly. 	<ol style="list-style-type: none"> 1. Contact The Lincoln Electric Service Department, (216) 383-2531 or 1-800-833-9353 (WELD).

⚠ **CAUTION**

If for any reason you do not understand the test procedures or are unable to perform the test/repairs safely, contact the Lincoln Electric Service Department for electrical troubleshooting assistance before you proceed. Call 216-383-2531 or 1-800-833-9353.



Return to Section TOC
Return to Master TOC

TROUBLESHOOTING & REPAIR

TROUBLESHOOTING GUIDE

Observe Safety Guidelines detailed in the beginning of this manual.

PROBLEMS (SYMPTOMS)	POSSIBLE AREAS OF MISADJUSTMENT(S)	RECOMMENDED COURSE OF ACTION
TIG MODE PROBLEMS		
Open circuit voltage is present at the output terminals even when the Arc Start switch or Amptrol is NOT actuated.	<ol style="list-style-type: none"> 1. The Arc Start switch or Amptrol may be defective. There should not be any continuity between pins "D" and "E" on the Arc Start cable connector, unless the unit is actuated. 	<ol style="list-style-type: none"> 1. Check the trigger circuit. Perform the Arc Start Trigger Circuit Test. 2. The control board may be faulty. Replace. 3. The power board may be faulty. Replace.
Arc rectification when AC TIG welding.	<ol style="list-style-type: none"> 1. The tungsten electrode may be too small for the process. 2. The AC Wave Balance control may be misadjusted. Adjust for more penetration. 3. If helium shielding gas is being used, reduce the percentage of helium. 	<ol style="list-style-type: none"> 1. Check components R6 and C6 in the high voltage transformer primary circuit. Replace if necessary. 2. Perform the SCR Rectifier Bridge Tests. 3. The control board may be faulty. Replace.

⚠ CAUTION

If for any reason you do not understand the test procedures or are unable to perform the test/repairs safely, contact the Lincoln Electric Service Department for electrical troubleshooting assistance before you proceed. Call 216-383-2531 or 1-800-833-9353.



Return to Section TOC
Return to Master TOC

TROUBLESHOOTING & REPAIR

TROUBLESHOOTING GUIDE

Observe Safety Guidelines detailed in the beginning of this manual.

PROBLEMS (SYMPTOMS)	POSSIBLE AREAS OF MISADJUSTMENT(S)	RECOMMENDED COURSE OF ACTION
TIG MODE PROBLEMS		
The machine output is intermittently lost. Gas flow and high frequency are also interrupted.	<ol style="list-style-type: none"> 1. The problem may be caused by high frequency interference. Make sure that the machine is grounded properly according to the installation instructions. If there are other high frequency sources in the area, make certain they are grounded properly. 2. Check the Arc Start switch or Ampctrl for proper operation and loose connections. 	<ol style="list-style-type: none"> 1. The machine internal ground connections may be loose. Check the mounting screws on the protection board, the bypass boards, and the feed-thru board. 2. The protection or bypass boards may be faulty. Check or replace. 3. Perform the Arc Start Trigger Circuit Test.
The arc "flutters" when TIG welding.	<ol style="list-style-type: none"> 1. The tungsten electrode may be too large in diameter. 2. The tungsten electrode may need sharpening. 3. If helium shielding gas is used, reduce the percentage of helium. 4. Adjust the gas flow rate to the proper level for the process being used. 5. Check gas hoses and connections for leaks. 	<ol style="list-style-type: none"> 1. Check for loose shunt connections, leads #222 and #221. See Wiring Diagram. 2. Check polarity switch for loose or faulty connections. 3. Perform the SCR Rectifier Bridge Tests. 4. Check components R6 and C6 in the high voltage transformer primary circuit. Replace if necessary. 5. The control board may be faulty. Replace. 6. The power board may be faulty. Replace.

CAUTION

If for any reason you do not understand the test procedures or are unable to perform the test/repairs safely, contact the Lincoln Electric Service Department for electrical troubleshooting assistance before you proceed. Call 216-383-2531 or 1-800-833-9353.

SQUARE WAVE TIG 355

TROUBLESHOOTING & REPAIR

TROUBLESHOOTING GUIDE

Observe Safety Guidelines detailed in the beginning of this manual.

PROBLEMS (SYMPTOMS)	POSSIBLE AREAS OF MISADJUSTMENT(S)	RECOMMENDED COURSE OF ACTION
FUNCTION PROBLEMS		
<p>The Pulsar does not seem to operate.</p>	<ol style="list-style-type: none"> 1. If the Start controls are used, pulsing does not begin until the end of the "start" time, which can be as much as 10 seconds. 2. Check the Pulses Per Second control. If it is set near minimum, each pulse may be as long as ten seconds. Set all three of the pulse controls near the midpoints to see the pulser's effects. 3. The Pulse % On control may be set at either extreme. If that is the case, the pulses may be too short to be seen. 	<ol style="list-style-type: none"> 1. Check the Pulse controls (R18, R19 and R20) for correct resistance and proper operation. See Wiring Diagram. 2. The control board may be faulty. Replace.
<p>The Spot Timer does not last as long as the nameplate setting.</p>	<ol style="list-style-type: none"> 1. When in the 2-Step trigger mode, be sure to keep the Arc Start switch or Amptrol pressed until the spot time is completed. Releasing the Arc Start switch before the Spot Timer has timed out will cause the arc to go out. 	<ol style="list-style-type: none"> 1. Check the Spot Timer control potentiometer (R16) for correct resistance and proper operation. 2. The control board may be faulty. Replace.
<p>The Spot Timer lasts much longer than the nameplate setting.</p>	<ol style="list-style-type: none"> 1. Make sure the Crater Fill switch is turned off. If it is on, the actual weld time will be the spot time plus the crater fill time. 	<ol style="list-style-type: none"> 1. Check the Spot Timer control potentiometer (R16) for correct resistance and proper operation. 2. The control board may be faulty. Replace.

⚠ CAUTION

If for any reason you do not understand the test procedures or are unable to perform the test/repairs safely, contact the Lincoln Electric Service Department for electrical troubleshooting assistance before you proceed. Call 216-383-2531 or 1-800-833-9353.



Return to Section TOC
Return to Master TOC

TROUBLESHOOTING & REPAIR

TROUBLESHOOTING GUIDE

Observe Safety Guidelines detailed in the beginning of this manual.

PROBLEMS (SYMPTOMS)	POSSIBLE AREAS OF MISADJUSTMENT(S)	RECOMMENDED COURSE OF ACTION
FUNCTION PROBLEMS		
<p>When using Crater Fill the arc goes out before the final crater fill current level is reached.</p>	<ol style="list-style-type: none"> 1. The Crater Fill % Peak Current control may be set too low for the tungsten being used. Increase the Crater Fill % Peak Current control until the final crater fill current is within the tungsten's operating range. 2. If using the Pulser in conjunction with the Crater Fill, the Background % Peak Current may be too low for the tungsten as the current is downsloping in crater fill. The best solution is to increase the Background % Peak Current level. 3. If welding with AC, use "Continuous" high frequency. The high frequency will stabilize the arc as the current goes down. 	<ol style="list-style-type: none"> 1. Check the Crater Fill Fade Out control potentiometer for correct resistance and proper operation. 2. The control board may be faulty. Replace.

⚠ CAUTION

If for any reason you do not understand the test procedures or are unable to perform the test/repairs safely, contact the Lincoln Electric Service Department for electrical troubleshooting assistance before you proceed. Call 216-383-2531 or 1-800-833-9353.



Return to Section TOC
Return to Master TOC

TROUBLESHOOTING & REPAIR

TROUBLESHOOTING GUIDE

Observe Safety Guidelines detailed in the beginning of this manual.

PROBLEMS (SYMPTOMS)	POSSIBLE AREAS OF MISADJUSTMENT(S)	RECOMMENDED COURSE OF ACTION
STICK WELDING PROBLEMS		
Stick electrode "blasts off" when touched to workpiece. The machine operates properly in the TIG mode.	<ol style="list-style-type: none"> 1. The weld current is set too high for electrode size. 2. If the Start switch is ON, the start current may be set too high for electrode size. 3. The Arc Force control may be set too high. 	<ol style="list-style-type: none"> 1. The control board may be faulty. Replace.
The arc seems too hot, and reducing the Peak Current control does not help. The machine operates properly in the TIG mode.	<ol style="list-style-type: none"> 1. The Arc Force control may be set too high. 2. If the Start switch is ON, the start current may be set too high or the start time may be set too long. 	<ol style="list-style-type: none"> 1. The control board may be faulty. Replace.

⚠ **CAUTION**

If for any reason you do not understand the test procedures or are unable to perform the test/repairs safely, contact the Lincoln Electric Service Department for electrical troubleshooting assistance before you proceed. Call 216-383-2531 or 1-800-833-9353.



Return to Section TOC
Return to Master TOC

TROUBLESHOOTING & REPAIR

INPUT POWER FACTOR CAPACITOR VOLTAGE CHECK AND DISCHARGE PROCEDURE

WARNING

Service and repair should be performed by only Lincoln Electric factory trained personnel. Unauthorized repairs performed on this equipment may result in danger to the technician or machine operator and will invalidate your factory warranty. For your safety and to avoid electrical shock, please observe all safety notes and precautions detailed throughout this manual.

If for any reason you do not understand the test procedures or are unable to perform the test/repairs safely, contact the Lincoln Electric Service Department for electrical troubleshooting assistance before you proceed. Call 216-383-2531 or 1-800-833-9353 (WELD).

PURPOSE FOR THE PROCEDURE

This procedure ensures that the power factor capacitors are discharged, for greater safety when you are working on the Square Wave TIG 355 with **INPUT POWER REMOVED**.

MATERIALS NEEDED

- Volt/Ohmmeter capable of testing 600 VAC
- 5/16" Nut driver
- Resistor (500 ohms, 25 watts minimum)

SQUARE WAVE TIG 355



TROUBLESHOOTING & REPAIR

INPUT POWER FACTOR CAPACITOR VOLTAGE CHECK AND DISCHARGE PROCEDURE *(continued)*

FIGURE F.1 – POWER FACTOR CAPACITOR DISCHARGE DETAILS

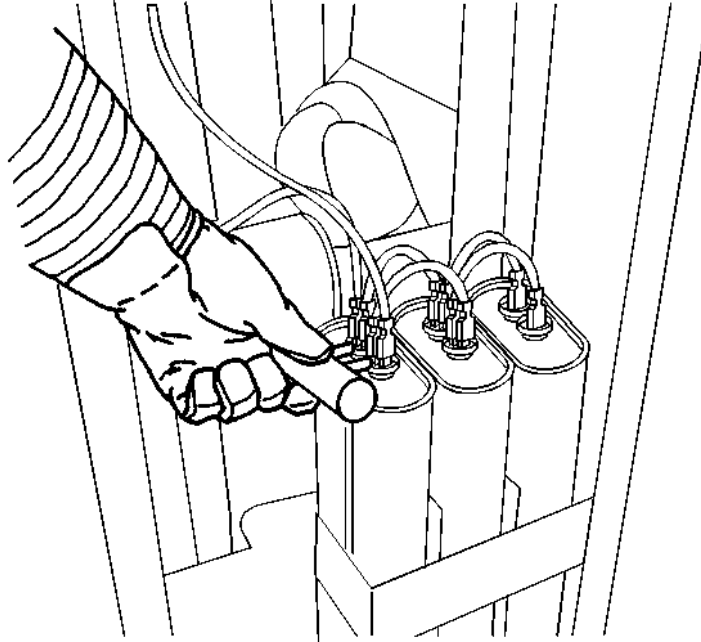

TEST PROCEDURE

1. Remove input power to the machine.
2. With the 5/16" nut driver, remove the sheet metal screws that hold the right case side in place. Remove the right case side.
3. With the volt/ohmmeter, carefully check the voltage across the input power factor capacitors. When input power is removed, the voltage across each capacitor should be zero. (Normally, the capacitors discharge through the primary winding in the main transformer.)
4. If capacitor voltage is zero, you may begin working on the Square Wave TIG 355.
5. If any voltage is present, DISCHARGE EACH INDIVIDUAL CAPACITOR as follows:
 - a. Grip the 500 ohm resistor with insulated gloves and insulated gripping pliers.
 - b. Hold the resistor across the terminals on each capacitor for 20 seconds. See Figure F.1.
 - c. With the volt/ohmmeter, recheck each capacitor for voltage.
6. After all the capacitors are discharged completely, check for broken capacitor leads or an open primary winding on the main transformer, which would have prevented the capacitors from discharging normally.

SQUARE WAVE TIG 355



TROUBLESHOOTING & REPAIR

ARC START TRIGGER CIRCUIT TEST

⚠ WARNING

Service and repair should be performed by only Lincoln Electric factory trained personnel. Unauthorized repairs performed on this equipment may result in danger to the technician or machine operator and will invalidate your factory warranty. For your safety and to avoid electrical shock, please observe all safety notes and precautions detailed throughout this manual.

If for any reason you do not understand the test procedures or are unable to perform the test/repairs safely, contact the Lincoln Electric Service Department for electrical troubleshooting assistance before you proceed. Call 216-383-2531 or 1-800-833-9353 (WELD).

TEST DESCRIPTION

This test will determine if the wiring and connections are good between the 6-pin amphenol receptacle and the protection board, and also between the protection board and the feed-thru board. It will also determine if 24 VAC is being supplied to the trigger circuit.

MATERIALS NEEDED

- Volt/Ohmmeter (Multimeter)
- 5/16" Nut driver
- Arc Start Trigger Circuit, Figure F.3
- Square Wave TIG Wiring Diagram (located in the Electrical Diagrams section of this manual)

SQUARE WAVE TIG 355



TROUBLESHOOTING & REPAIR

ARC START TRIGGER CIRCUIT TEST *(continued)*

FIGURE F.2 – 6-PIN AMPHENOL RECEPTACLE

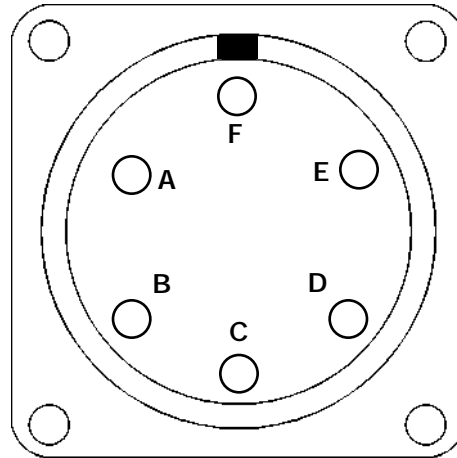

TEST PROCEDURE

1. Remove input power to the machine.
2. With the 5/16" nut driver, remove the screws and carefully lower the front control panel.
3. Locate plug J9 on the control PC board.

⚠ WARNING



ELECTRIC SHOCK can kill.

- With input power ON, there are high voltages inside the machine. Do not reach into the machine or touch any internal part of the machine while power is on.

4. Turn on input power to the machine.
5. Close the Arc Start switch or jumper pins "D" to "E" at the 6-pin amphenol receptacle. See Figure F.2.
6. With the volt/ohmmeter, check for 24 VAC at pins 1J9 to 3J9.
 - If 24 VAC is present, the control PC board may be faulty. NOTE: 24 VAC should be present at pins 1J9 to 3J9 only when the Arc Start switch is closed.
 - If 24 VAC is missing or low, check for 24 VAC at the T5 transformer. See the Wiring Diagram. If 24 VAC is missing or low at the transformer leads, perform the Control Transformer Test.
 - If 24 VAC is present at the transformer leads, remove input power to the machine and check the continuity and resistance of the leads and coils on and between the feed-thru board and the protection board. See Figure F.3.
7. Also check the continuity of the leads from the protection board to the 14-pin amphenol receptacle. It should be zero ohms. See the Wiring Diagram.
8. After the tests are complete, install the front control panel, using the 5/16" nut driver.

SQUARE WAVE TIG 355



TROUBLESHOOTING & REPAIR

ARC START TRIGGER CIRCUIT TEST *(continued)*

FIGURE F.3 – ARC START TRIGGER CIRCUIT

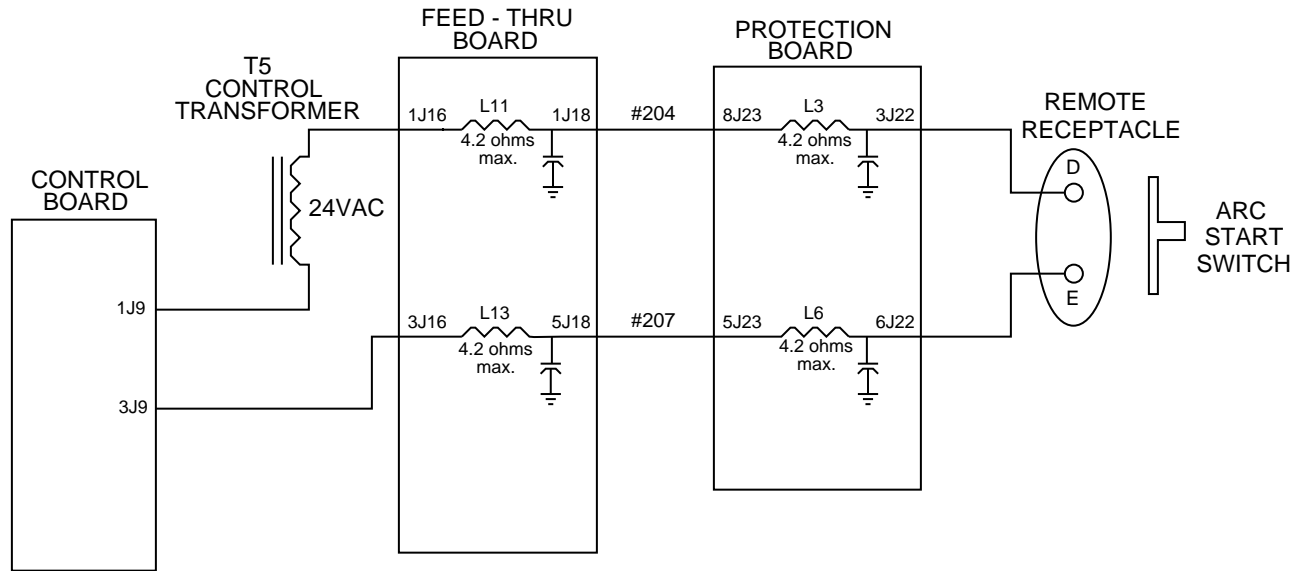

Return to Section TOC
 Return to Section TOC
 Return to Section TOC
 Return to Section TOC
 Return to Master TOC
 Return to Master TOC
 Return to Master TOC
 Return to Master TOC

SQUARE WAVE TIG 355



TROUBLESHOOTING & REPAIR

POWER BOARD TEST

WARNING

Service and repair should be performed by only Lincoln Electric factory trained personnel. Unauthorized repairs performed on this equipment may result in danger to the technician or machine operator and will invalidate your factory warranty. For your safety and to avoid electrical shock, please observe all safety notes and precautions detailed throughout this manual.

If for any reason you do not understand the test procedures or are unable to perform the test/repairs safely, contact the Lincoln Electric Service Department for electrical troubleshooting assistance before you proceed. Call 216-383-2531 or 1-800-833-9353 (WELD).

TEST DESCRIPTION

This test will determine if the correct input voltages are being supplied to the power board and also if the proper voltages are being generated by the power board.

MATERIALS NEEDED

- Volt/Ohmmeter (Multimeter)
- 5/16" Nut driver
- Power Board Voltage Test Chart
- Square Wave TIG Wiring Diagram (located in the Electrical Diagrams section of this manual)

SQUARE WAVE TIG 355



TROUBLESHOOTING & REPAIR

POWER BOARD TEST (continued)

FIGURE F.4 - POWER BOARD TEST POINTS

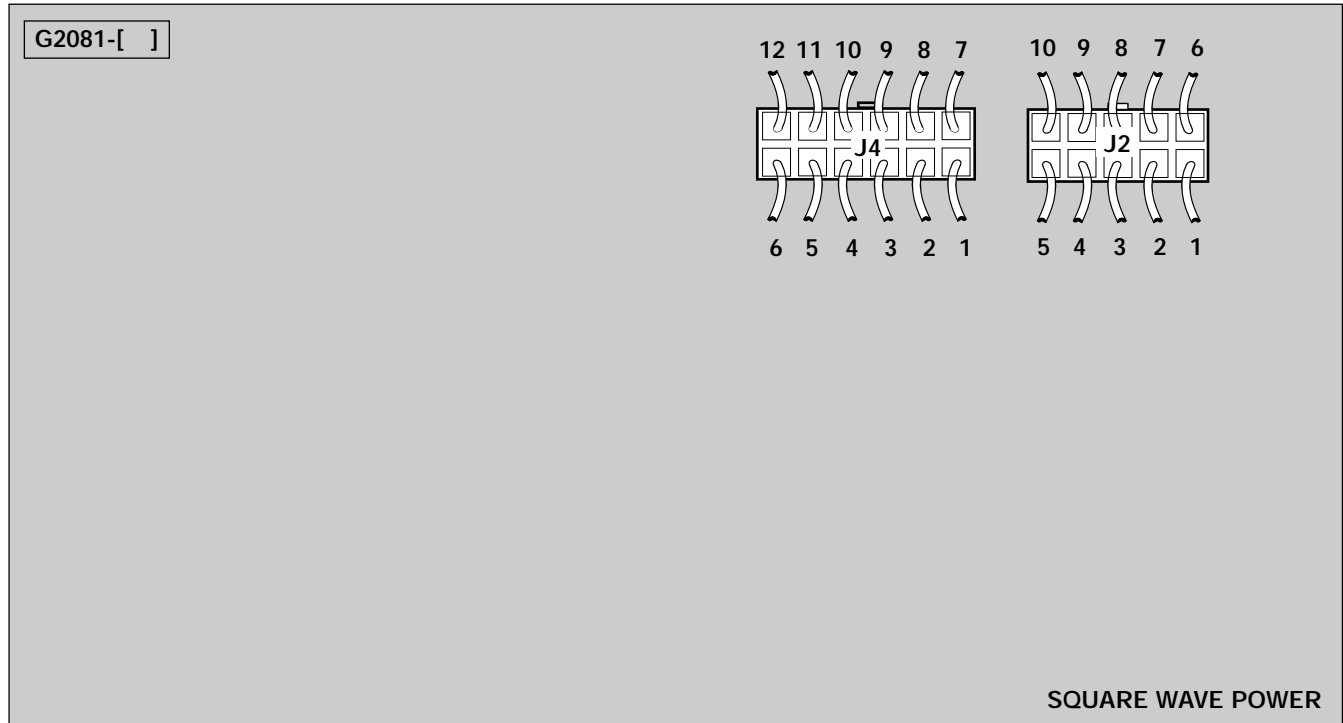

TEST PROCEDURE

1. Remove input power to the machine.
 2. With the 5/16" nut driver, remove the screws and carefully lower the front control panel.
 3. On the power board, locate the test points that are called out in the following Power Board Voltage Test Chart. See Figure F.4.
 4. Connect the volt/ohmmeter to each set of test points and compare your reading to the expected reading from the chart.
 5. After the tests are completed and the problem repaired, install the front control panel, using the 5/16" nut driver.
- Apply power and press the start button.
 - If the correct voltages are being applied to the power board but NOT generated by the power board, the power board may be faulty.
 - If the background voltages are NOT being applied to the power board, the control transformer, the background rectifier, or the associated wiring may be faulty.

⚠ WARNING



ELECTRIC SHOCK can kill.

- With input power ON, there are high voltages inside the machine. Do not reach into the machine or touch any internal part of the machine while power is on.

SQUARE WAVE TIG 355



TROUBLESHOOTING & REPAIR

POWER BOARD VOLTAGE TEST CHART

Check Points	Signals Being Checked	Expected Reading	Special Conditions for Test
IJ4 to 2J4	AC supply voltage from T5 transformer	10VAC	None
4J4 to 6J4	AC supply voltage from T5 transformer	32VAC	None
4J4 to 5J4	AC supply voltage from T5 transformer	16VAC	None
10J4 to 12J4	AC supply voltage from T5 transformer	36VAC	None
3J2(+) to 5J2	Regulated +15VDC	+15VDC	LED 1 ON
4J2(-) to 5J2	Regulated -15VDC	-15VDC	LED 2 ON
IJ2(+) to 2J2	Unregulated DC	+14VDC	None

Note: LED 3 should be ON when gate signal is applied to SCR 1.
LED 4 should be ON when gate signal is applied to SCR 4.

SQUARE WAVE TIG 355



TROUBLESHOOTING & REPAIR

INPUT CONTACTOR TEST

⚠ WARNING

Service and repair should be performed by only Lincoln Electric factory trained personnel. Unauthorized repairs performed on this equipment may result in danger to the technician or machine operator and will invalidate your factory warranty. For your safety and to avoid electrical shock, please observe all safety notes and precautions detailed throughout this manual.

If for any reason you do not understand the test procedures or are unable to perform the test/repairs safely, contact the Lincoln Electric Service Department for electrical troubleshooting assistance before you proceed. Call 216-383-2531 or 1-800-833-9353 (WELD).

TEST DESCRIPTION

This test will determine if the input contactor is receiving the correct coil voltage and if the contacts are functioning correctly.

MATERIALS NEEDED

- Volt/Ohmmeter (Multimeter)
- 5/16" Nut driver
- External 120 VAC supply
- Input Contactor (CR1) Simplified Control Circuit, Figure F.6
- Square Wave TIG Wiring Diagram (located in the Electrical Diagrams section of this manual)

SQUARE WAVE TIG 355



TROUBLESHOOTING & REPAIR

INPUT CONTACTOR TEST *(continued)*

FIGURE F.5 - INPUT CONTACTOR TEST POINTS

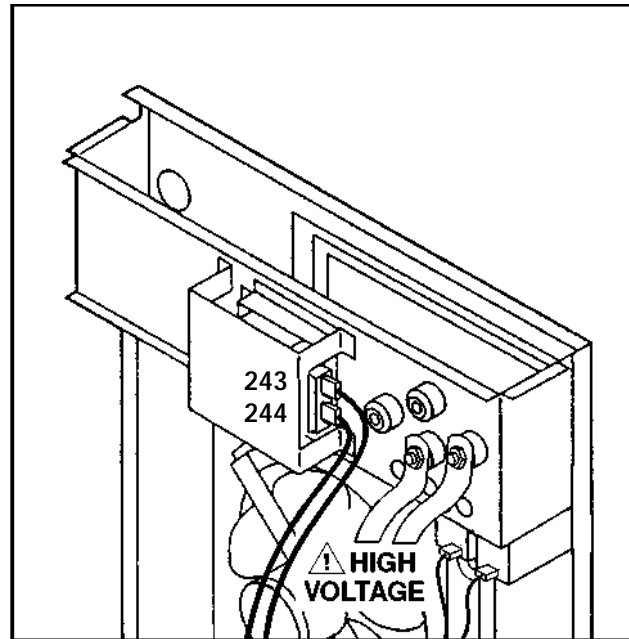

TEST PROCEDURE

1. Remove input power to the machine.
2. With the 5/16" nut driver, remove the machine top and sides.
3. Locate the two leads, #243 and #244, connected to the input contactor coil. See Figure F5.
4. Connect the volt/ohmmeter to the leads.

⚠ WARNING



ELECTRIC SHOCK can kill.

- With input power ON, there are high voltages inside the machine. Do not reach into the machine or touch any internal part of the machine while power is on.

⚠ WARNING

ELECTRICAL ARCING can injure.

- Never mechanically close the contactor with input power (line voltage) applied and the machine contactor cover removed.

5. Turn on input power to the machine and press the Start button.
6. Check for 120 VAC at the contactor coil leads.
 - If 120 VAC is NOT present when the Start button is pressed, check the normally closed (NC) secondary thermostat, the power Start/Stop pushbutton and associated circuitry. See Figure F.6, Input Contactor (CR1) Simplified Control Circuit. Also perform the Pilot Transformer Test.
 - If 120 VAC is present and the contactor does not activate, the input contactor is faulty. Replace.

SQUARE WAVE TIG 355



TROUBLESHOOTING & REPAIR

INPUT CONTACTOR TEST *(continued)*

- If 120 VAC is present when the Start button is held in but the contactor does not stay activated when the button is released, check the CR1 interlock, the power Start/Stop pushbutton, and associated circuitry. See Figure F.6, Input Contactor (CR1) Simplified Control Circuit. Also perform the Control Board Test.

Test for Contact Continuity

1. Remove ALL input power to the machine.
2. Perform the power factor capacitor discharge procedure.
3. Locate the two leads, #243 and #244, connected to the input contactor coil. See Figure F.6.
4. Use the external 120 VAC supply to apply power to the input contactor coil.
 - If the contactor does NOT activate, it is faulty. Replace.
 - If the contactor does activate, check the continuity across the contacts. A normal reading should be zero ohms or very low ohms.
 - If the resistance is high, the contactor is faulty. Replace.
5. With the contactor NOT activated, check the continuity across the contacts. See Figure F.6.
 - If the resistance is infinite or very high across the contacts, the contactor is good.
 - If the resistance is low, the contactor is faulty. Replace.
6. After the tests are completed and the problem repaired, install the machine sides and top, using the 5/16" nut driver.

SQUARE WAVE TIG 355



TROUBLESHOOTING & REPAIR

INPUT CONTACTOR TEST *(continued)*

FIGURE F.6 - INPUT CONTACTOR (CR1) SIMPLIFIED CONTROL CIRCUIT

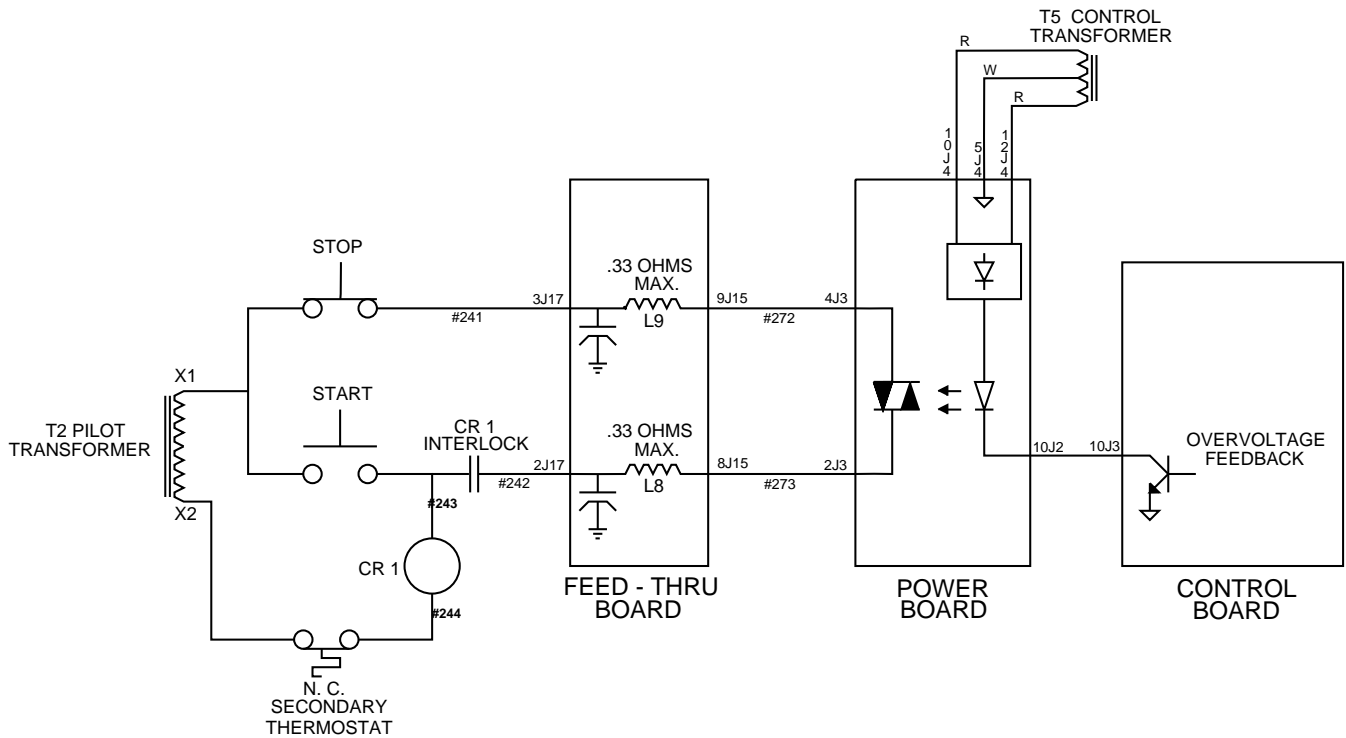

SQUARE WAVE TIG 355



Return to Section TOC

Return to Section TOC

Return to Section TOC

Return to Section TOC

Return to Master TOC

Return to Master TOC

Return to Master TOC

Return to Master TOC

TROUBLESHOOTING & REPAIR

PILOT TRANSFORMER TEST

⚠ WARNING

Service and repair should be performed by only Lincoln Electric factory trained personnel. Unauthorized repairs performed on this equipment may result in danger to the technician or machine operator and will invalidate your factory warranty. For your safety and to avoid electrical shock, please observe all safety notes and precautions detailed throughout this manual.

If for any reason you do not understand the test procedures or are unable to perform the test/repairs safely, contact the Lincoln Electric Service Department for electrical troubleshooting assistance before you proceed. Call 216-383-2531 or 1-800-833-9353 (WELD).

TEST DESCRIPTION

This test will determine if the correct voltage is being applied to the primary of the pilot transformer and induced on the secondary.

MATERIALS NEEDED

Volt/Ohmmeter (Multimeter)
5/16" Nut driver
Square Wave TIG Wiring Diagram (located in the Electrical Diagrams section of this manual)

SQUARE WAVE TIG 355



TROUBLESHOOTING & REPAIR

PILOT TRANSFORMER TEST *(continued)*

FIGURE F.7 - PILOT TRANSFORMER CONNECTIONS

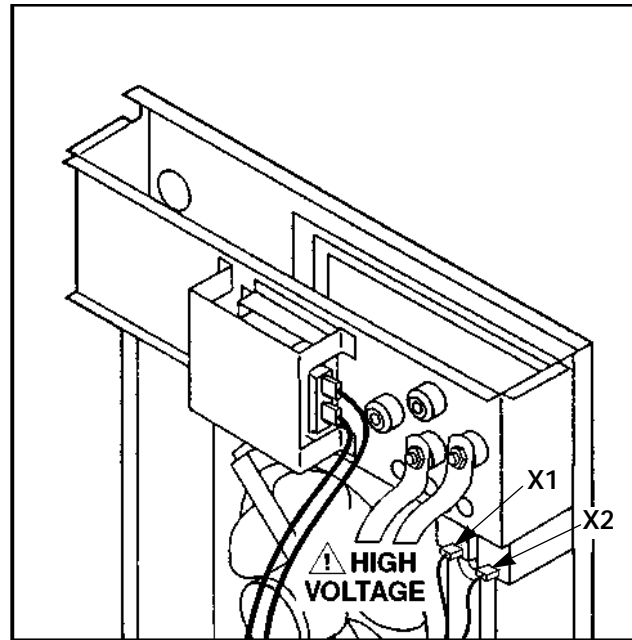

TEST PROCEDURE

1. Remove input power to the machine.
2. With the 5/16" nut driver, remove the machine top and sides.
3. Locate terminals X1 and X2 connected to the pilot transformer secondary. See Figure F.7.
4. Connect the volt/ohmmeter to X1 and X2.
6. Check for 120 VAC at the X1 and X2 terminals.
 - If 120 VAC is present at X1 and X2, the pilot transformer is good.
 - If 120 VAC is NOT present at X1 and X2, check for the correct primary voltage at leads H1 to HX, depending on the input voltage being applied to the machine. See the machine Wiring Diagram.

⚠ WARNING

ELECTRIC SHOCK can kill.



- With input power ON, there are high voltages inside the machine. Do not reach into the machine or touch any internal part of the machine while power is on.

NOTE: H1 is located at L1 on the input side of CR1 input contactor.

If the correct voltage is being applied to the primary of the pilot transformer and 120 VAC is not present at terminals X1 and X2 of the secondary winding, the pilot transformer may be faulty. Replace.

NOTE: The secondary voltage will vary with fluctuations in the input line voltage.

5. Turn on input power to the machine.
7. After the tests are completed and the problem repaired, install the machine sides and top, using the 5/16" nut driver.

SQUARE WAVE TIG 355



TROUBLESHOOTING & REPAIR

FEED-THRU PC BOARD TEST

⚠ WARNING

Service and repair should be performed by only Lincoln Electric factory trained personnel. Unauthorized repairs performed on this equipment may result in danger to the technician or machine operator and will invalidate your factory warranty. For your safety and to avoid electrical shock, please observe all safety notes and precautions detailed throughout this manual.

If for any reason you do not understand the test procedures or are unable to perform the test/repairs safely, contact the Lincoln Electric Service Department for electrical troubleshooting assistance before you proceed. Call 216-383-2531 or 1-800-833-9353 (WELD).

TEST DESCRIPTION

This test will determine if the feed-thru PC board circuitry is intact and capable of passing signal currents.

MATERIALS NEEDED

- Volt/Ohmmeter (Multimeter)
- 5/16" Nut driver
- Phillips head screw driver
- Square Wave TIG Wiring Diagram (located in the Electrical Diagrams section of this manual)
- Feed-Thru PC Board Schematic
- Feed-Thru PC Board Resistance Test Points Chart

SQUARE WAVE TIG 355



TROUBLESHOOTING & REPAIR

FEED-THRU PC BOARD TEST *(continued)*

FIGURE F.8 - FEED-THRU PC BOARD LOCATION

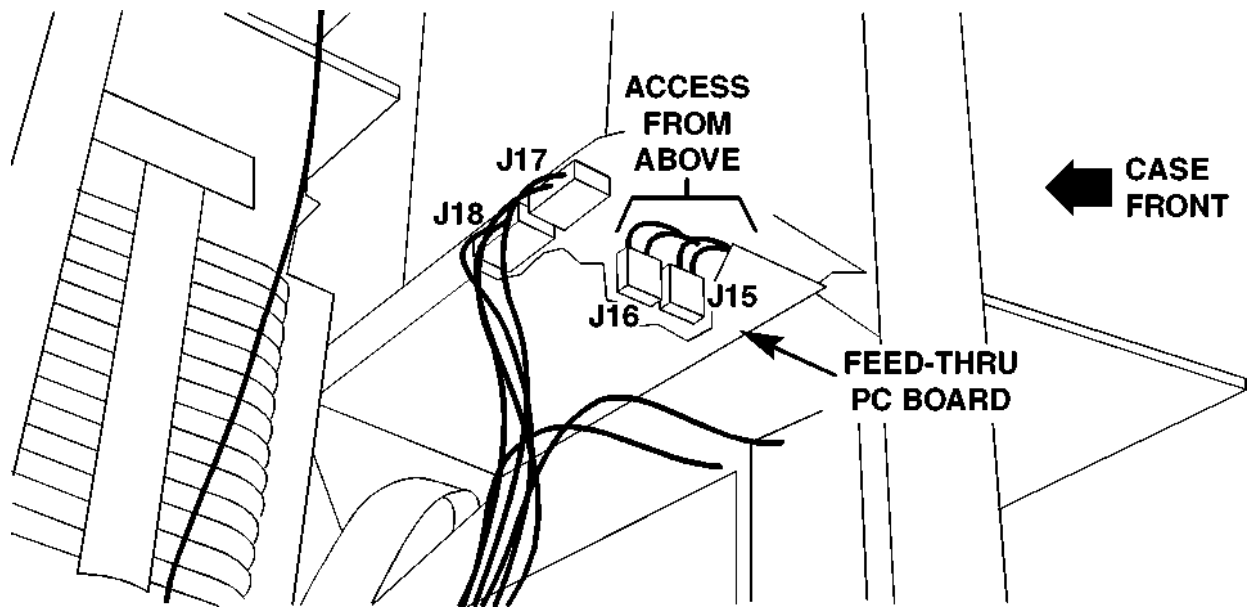

TEST PROCEDURE

1. Remove input power to the machine.
2. With the 5/16" nut driver, remove the machine top and sides.
3. Perform the power factor capacitor discharge procedure.
4. Remove plugs J15, J16, J17, and J18 from the feed-thru PC board. See Figure F.8 for location.
5. Remove the 4 phillips head screws mounting the feed-thru PC board to the floor of the control box. See Figure F.8.
6. Carefully remove the feed-thru PC board.
7. Test for the resistances between the check points listed on the Feed-Thru PC Board Resistance Test Points Chart. See Figures F.9 and F.10.
8. After the tests are completed and the problem repaired, install and connect the feed-thru PC board:
 - Carefully mount the board to the floor of the control box using the 4 phillips head screws.
 - Connect plugs J15, J16, J17, and J18 to the board.
9. With the 5/16" nut driver, install the machine sides and top.
- If any of the resistances are out of specification, replace the feed-thru PC board.

SQUARE WAVE TIG 355



TROUBLESHOOTING & REPAIR

FEED-THRU PC BOARD TEST (continued)

FIGURE F.9 - FEED-THRU PC BOARD PLUG DETAILS - PLUGS J15 AND J16

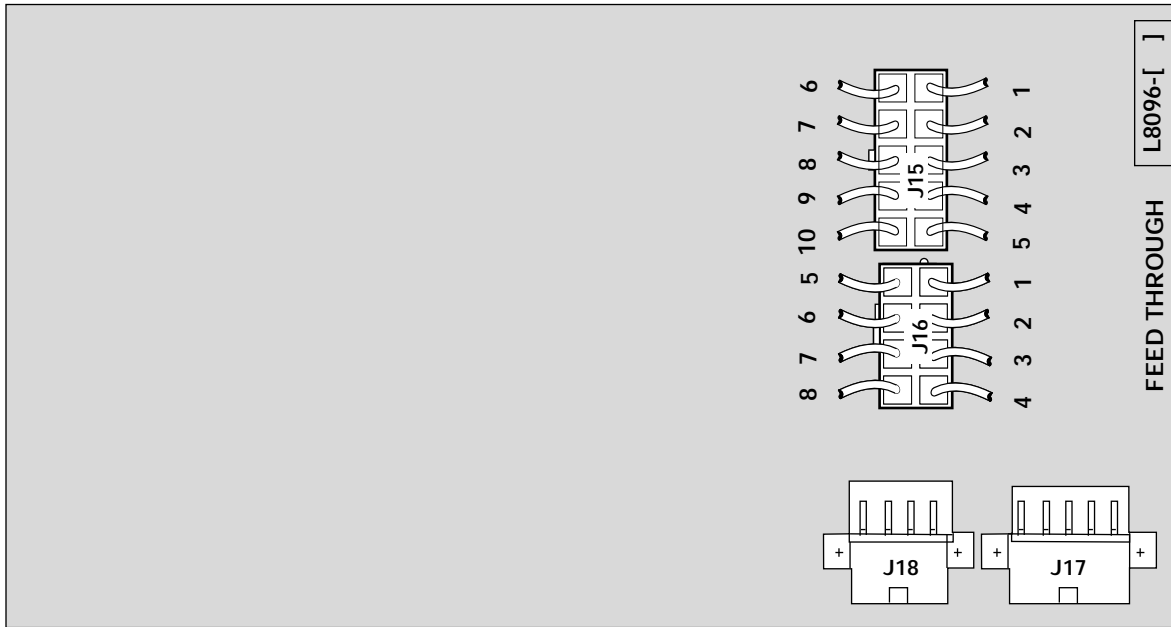
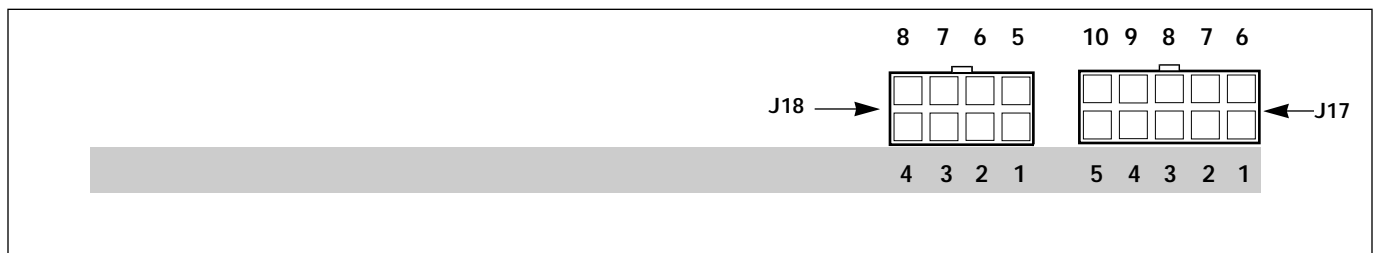

FIGURE F.10 - FEED-THRU PC BOARD PLUG DETAILS - PLUGS J17 AND J18



VIEW FROM EDGE OF BOARD

SQUARE WAVE TIG 355



Return to Section TOC

Return to Section TOC

Return to Section TOC

Return to Section TOC

Return to Master TOC

Return to Master TOC

Return to Master TOC

Return to Master TOC

TROUBLESHOOTING & REPAIR

FEED-THRU PC BOARD TEST *(continued)*

FEED THRU PC BOARD RESISTANCE TEST POINTS

Check Points	Component(s) Being Checked	Maximum Allowable Resistance
5J15 to 7J17	L1 and Board Trace	4.2 OHMS (3.9 Typical)
4J15 to 6J17	L2 and Board Trace	4.2 OHMS (3.9 Typical)
6J15 to 10J17	L4 and Board Trace	.60 OHMS (.50 Typical)
7J15 to 9J17	L5 and Board Trace	.60 OHMS (.50 Typical)
10J15 to 4J17	L6 and Board Trace	.60 OHMS (.50 Typical)
2J15 to 1J17	L7 and Board Trace	.60 OHMS (.50 Typical)
8J15 to 2J17	L8 and Board Trace	.60 OHMS (.50 Typical)
9J15 to 3J17	L9 and Board Trace	.60 OHMS (.50 Typical)
1J15 to 5J17	L10 and Board Trace	.60 OHMS (.50 Typical)
1J16 to 1J18	L11 and Board Trace	4.2 OHMS (3.9 Typical)
2J16 to 8J17	L12 and Board Trace	4.2 OHMS (3.9 Typical)
3J16 to 5J18	L13 and Board Trace	4.2 OHMS (3.9 Typical)
5J16 to 4J18	L15 and Board Trace	4.2 OHMS (3.9 Typical)
6J16 to 8J18	L16 and Board Trace	4.2 OHMS (3.9 Typical)
7J16 to 7J18	L17 and Board Trace	4.2 OHMS (3.9 Typical)
8J16 to 6J18	L18 and Board Trace	4.2 OHMS (3.9 Typical)

SQUARE WAVE TIG 355



TROUBLESHOOTING & REPAIR

PROTECTION PC BOARD TEST

WARNING

Service and repair should be performed by only Lincoln Electric factory trained personnel. Unauthorized repairs performed on this equipment may result in danger to the technician or machine operator and will invalidate your factory warranty. For your safety and to avoid electrical shock, please observe all safety notes and precautions detailed throughout this manual.

If for any reason you do not understand the test procedures or are unable to perform the test/repairs safely, contact the Lincoln Electric Service Department for electrical troubleshooting assistance before you proceed. Call 216-383-2531 or 1-800-833-9353 (WELD).

TEST DESCRIPTION

This test will determine if the protection PC board circuitry is intact and capable of passing signal currents.

MATERIALS NEEDED

- Volt/Ohmmeter (Multimeter)
- 5/16" Nut driver
- Phillips head screw driver
- Square Wave TIG Wiring Diagram (located in the Electrical Diagrams section of this manual)
- Protection PC Board Schematic
- Protection PC Board Resistance Test Points Chart

SQUARE WAVE TIG 355



Return to Section TOC
Return to Master TOC
Return to Section TOC
Return to Master TOC
Return to Section TOC
Return to Master TOC
Return to Section TOC
Return to Master TOC

TROUBLESHOOTING & REPAIR

PROTECTION PC BOARD TEST *(continued)*

FIGURE F.11- PROTECTION PC BOARD LOCATION AND MOUNTING DETAILS

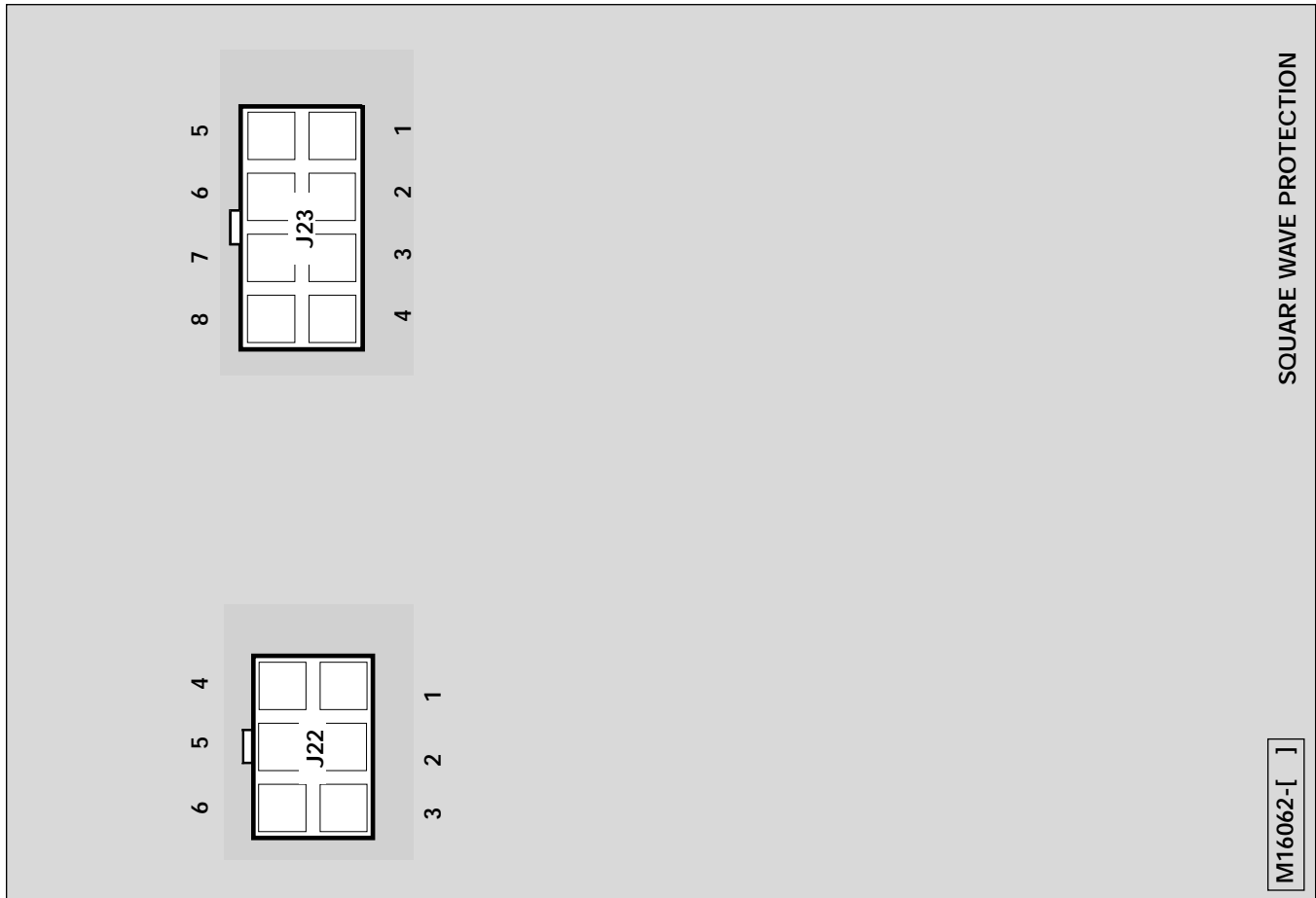

TEST PROCEDURE

1. Remove input power to the machine.
2. With the 5/16" nut driver, remove the screws and carefully lower the front control panel.
3. Remove plugs J22 and J23 from the protection PC board. See Figure F.11 for location.
4. With the phillips head screw driver, remove the three screws mounting the protection PC board to the front panel. Note washer placement.
5. Carefully remove the protection PC board.
6. Test for the resistances between the check points listed on the Protection PC Board Resistance Test Points Chart.
 - If any of the resistances are out of specification, replace the protection PC board.
7. After the tests are complete and the problem repaired, install and connect the protection PC board.
 - Carefully mount the protection PC board to the front panel. Take note of the washer placement; the washers must be replaced correctly to be sure that the protection PC board is grounded properly. See Figure F.11.
 - Connect plugs J22 and J23.
8. Install the front control panel, using the 5/16" nut driver.

SQUARE WAVE TIG 355



TROUBLESHOOTING & REPAIR

PROTECTION PC BOARD TEST *(continued)*

PROTECTION PC BOARD RESISTANCE TEST POINTS CHART

Test Points	Component(s) Being Tested	Maximum Allowable Resistance
1J22 to 3J23	L1 and Board Trace	4.2 OHMS (3.9 Typical)
2J22 to 4J23	L2 and Board Trace	4.2 OHMS (3.9 Typical)
3J22 to 7J23	L3 and Board Trace	4.2 OHMS (3.9 Typical)
5J22 to 1J23	L4 and Board Trace	4.2 OHMS (3.9 Typical)
4J22 to 2J23	L5 and Board Trace	4.2 OHMS (3.9 Typical)
6J22 to 5J23	L6 and Board Trace	4.2 OHMS (3.9 Typical)
3J22 to 8J23	L3 and Board Trace	4.2 OHMS (3.9 Typical)
7J23 to 8J23	Board Trace	Zero (0) Ohms

SQUARE WAVE TIG 355



TROUBLESHOOTING & REPAIR

MAIN TRANSFORMER TEST

⚠ WARNING

Service and repair should be performed by only Lincoln Electric factory trained personnel. Unauthorized repairs performed on this equipment may result in danger to the technician or machine operator and will invalidate your factory warranty. For your safety and to avoid electrical shock, please observe all safety notes and precautions detailed throughout this manual.

If for any reason you do not understand the test procedures or are unable to perform the test/repairs safely, contact the Lincoln Electric Service Department for electrical troubleshooting assistance before you proceed. Call 216-383-2531 or 1-800-833-9353 (WELD).

TEST DESCRIPTION

This test will determine if the correct voltage is being applied to the primary of the main transformer and induced on the secondary and auxiliary windings.

MATERIALS NEEDED

- Volt/Ohmmeter (Multimeter)
- 5/16" Nut driver
- Square Wave TIG Wiring Diagram (located in the Electrical Diagrams section of this manual)
- Main Transformer Voltage and Test Points Chart

SQUARE WAVE TIG 355



TROUBLESHOOTING & REPAIR

MAIN TRANSFORMER TEST *(continued)*

FIGURE F.12 - MAIN TRANSFORMER LOCATION AND WIRING DETAILS

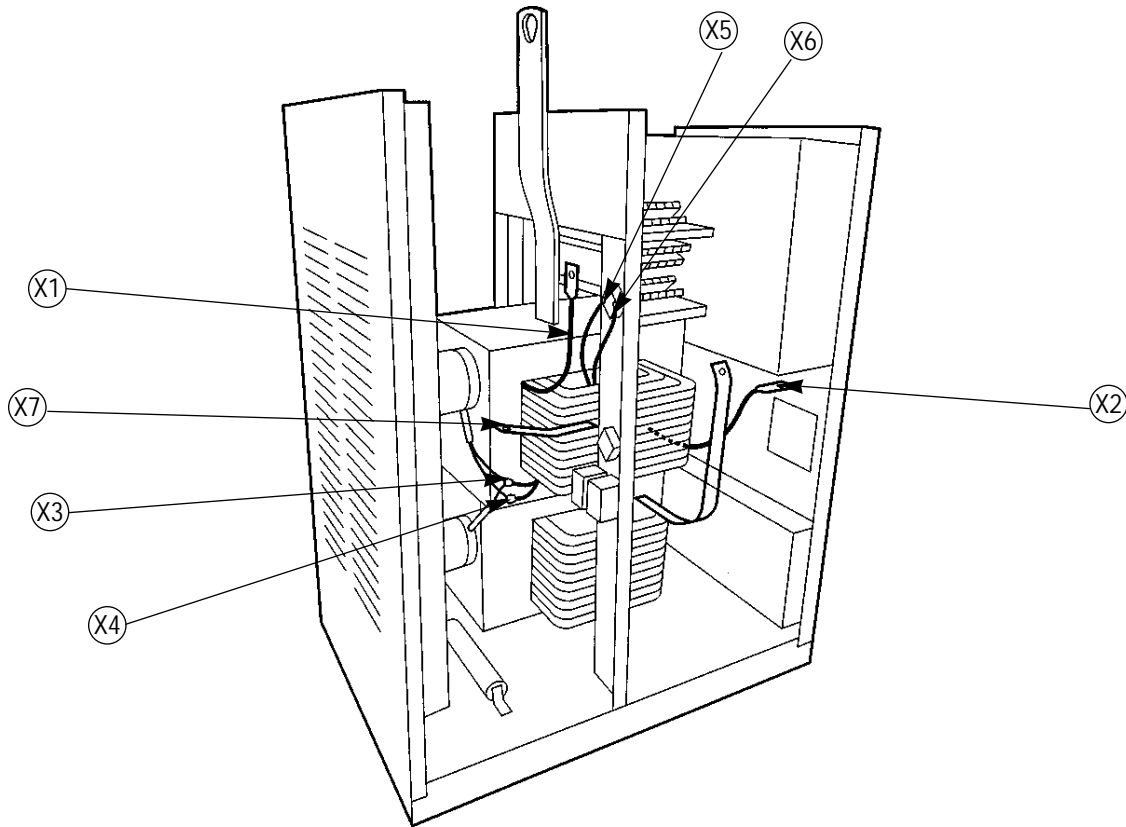

TEST PROCEDURE

1. Remove input power to the machine.
2. With the 5/16" nut driver, remove the machine top and sides.
3. Perform the power factor capacitor discharge procedure.
4. Inspect the input contactor, reconnect panel, and primary leads to the main transformer for loose or faulty connections.
5. Check the reconnect panel to make sure that the single phase AC power supplied to the machine is properly connected.
6. Locate leads X1 through X7. See Figure F.12.



WARNING

ELECTRIC SHOCK can kill.

- With input power ON, there are high voltages inside the machine. Do not reach into the machine or touch any internal part of the machine while power is on.



7. Turn on input power to the machine.

SQUARE WAVE TIG 355



TROUBLESHOOTING & REPAIR

MAIN TRANSFORMER TEST *(continued)*

7. Check the voltages at the test points listed on the Main Transformer Voltage Test Points Chart.

NOTE: Readings will fluctuate if line voltages fluctuate.

- If any of the secondary or auxiliary voltages is missing or out of specification and the correct input voltage is applied to the primary winding, the main transformer may be faulty.

- If all the secondary or auxiliary voltages are low or missing and the correct input voltage is applied to the main transformer, then the primary winding is faulty.

8. After the tests are completed and the problem repaired, install the machine sides and top, using the 5/16" nut driver.

MAIN TRANSFORMER VOLTAGE TEST POINTS CHART

Secondary and Auxiliary Leads	Test Point Location	Approximate Voltages
X1 to X2	Aluminum secondary leads	84 to 89VAC
X3 to X4	120VAC receptacle	117 to 125VAC
X5 to X6	Background rectifier	22 to 24VAC
X2 to X7	Aluminum secondary leads	77 to 81VAC

NOTE: Readings will fluctuate if line voltages are unusually high or low.

SQUARE WAVE TIG 355



TROUBLESHOOTING & REPAIR

CONTROL TRANSFORMER (T5) VOLTAGE TEST

⚠ WARNING

Service and repair should be performed by only Lincoln Electric factory trained personnel. Unauthorized repairs performed on this equipment may result in danger to the technician or machine operator and will invalidate your factory warranty. For your safety and to avoid electrical shock, please observe all safety notes and precautions detailed throughout this manual.

If for any reason you do not understand the test procedures or are unable to perform the test/repairs safely, contact the Lincoln Electric Service Department for electrical troubleshooting assistance before you proceed. Call 216-383-2531 or 1-800-833-9353 (WELD).

TEST DESCRIPTION

The following procedure will determine if the correct voltage is being applied to the primary of the control transformer and induced on the secondary.

MATERIALS NEEDED

- Volt/Ohmmeter (Multimeter)
- 5/16" Nut Driver
- Machine Wiring Diagrams (See the Electrical Diagram Section of this manual.)
- Control Transformer (T5) Voltage Test Chart and drawing of transformer and molex plug (P4), Figure F.14.

SQUARE WAVE TIG 355



TROUBLESHOOTING & REPAIR

CONTROL TRANSFORMER (T5) VOLTAGE TEST *(continued)*

FIGURE F.13 - LOCATION OF CONTROL BOARD AND CONTROL TRANSFORMER

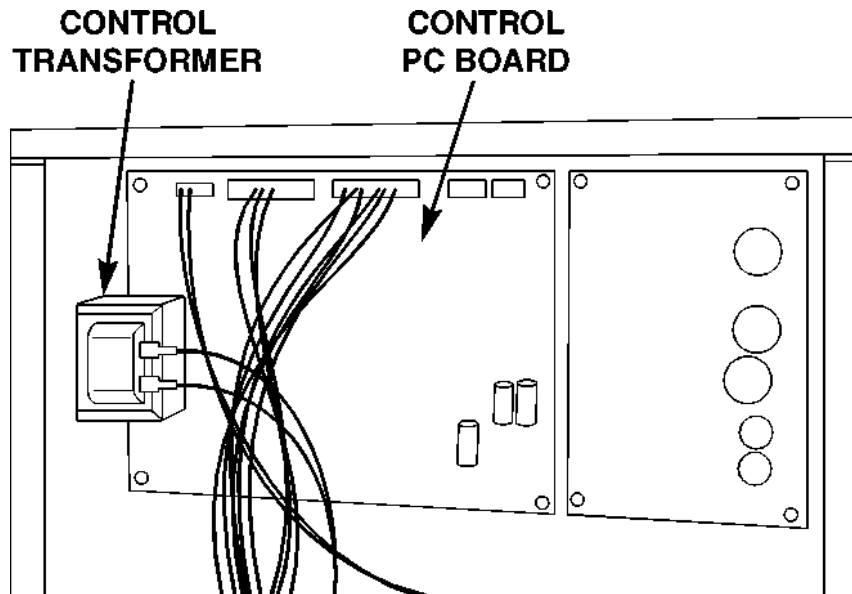
**TEST PROCEDURE**

1. Remove input power to the machine.
2. With the 5/16" nut driver, remove the machine case top and sides.
3. Locate plug J4 on the power board. (Do not remove.) Also locate the two black secondary leads. See Figure F.13.
4. Check for 120VAC at the primary leads #265 to #266.
 - A. If 120VAC is present at leads #265 to #266, go to Step 7.
 - B. If a very low or zero voltage is shown at leads #265 to #266, go to Step 5.
5. Remove input power to machine.

Note: If input voltage varies, the control transformer voltages will vary accordingly.

⚠ WARNING

ELECTRIC SHOCK can kill.



- With input power ON, there are high voltages inside the machine. Do not reach into the machine or touch any internal part of the machine while power is on.

3. Turn input power ON.

SQUARE WAVE TIG 355



TROUBLESHOOTING & REPAIR

CONTROL TRANSFORMER (T5) VOLTAGE TEST *(continued)*

FIGURE F.14 – PLUG P4 DETAILS

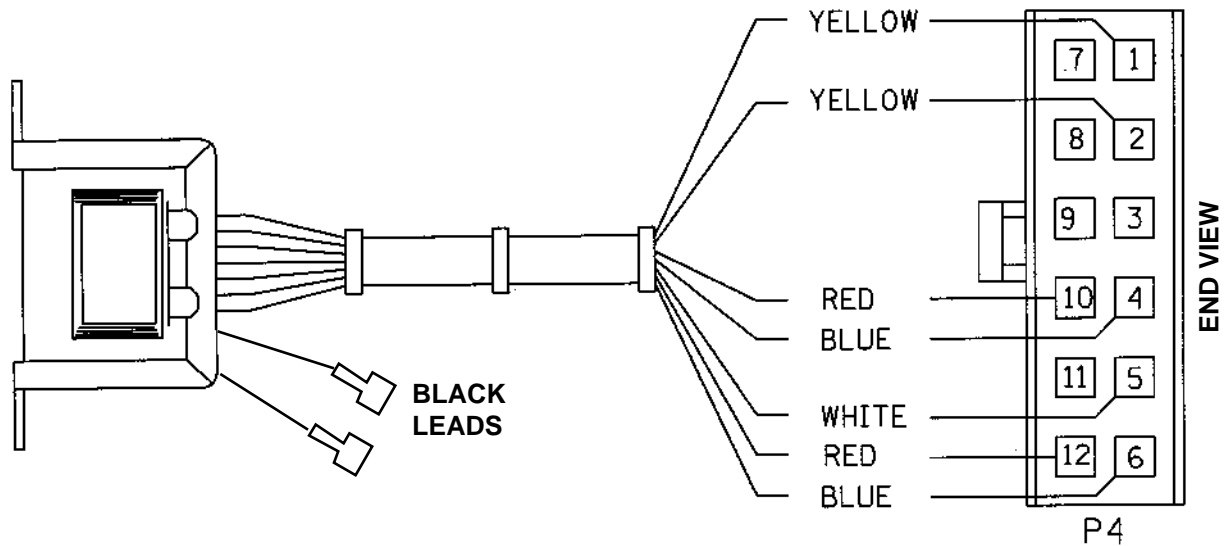

6. Check fuse F1 (0.5 amp). Test the resistance from 6J15, on the feed-thru PC board, to the #265 lead at the control transformer. Also check the resistance from 7J15, on the feed-thru PC board, to the #266 lead at the control transformer.
 - A. If zero ohms resistance is shown, the test is OK. Proceed to the feed-thru PC board continuity test.
 - B. If resistance of any value is shown, check wires and connections.
7. Test for the correct AC voltages at Plug P4. See Figure F.14.
 - A. If one or more voltages are missing or incorrect, the control transformer is faulty. Replace.
 - B. Also check for 24VAC at the two black leads going to 1J16 on the feed-thru PC board and 1J9 on the control PC board.

IMPORTANT: If the control transformer is replaced, refer to the label on the new transformer for correct primary lead connections. If connected wrong, the machine will have no OCV output. If no OCV occurs, reverse the control transformer primary connections and recheck machine OCV.

NOTE: If input voltage varies, control transformer voltages will vary accordingly.

CONTROL TRANSFORMER (T5) VOLTAGE TEST CHART

Secondary Lead Colors	Plug P4 Pins	Approximate Voltages
Yellow to Yellow	1 to 2	10VAC
Blue to Blue	4 to 6	32VAC
White to Blue	5 to 6	16VAC
Red to White	10 to 5	18VAC
Red to Red	10 to 12	36VAC

SQUARE WAVE TIG 355



Return to Section TOC

Return to Section TOC

Return to Section TOC

Return to Section TOC

Return to Master TOC

Return to Master TOC

Return to Master TOC

Return to Master TOC

TROUBLESHOOTING & REPAIR

CONTROL PC BOARD TEST

⚠ WARNING

Service and repair should be performed by only Lincoln Electric factory trained personnel. Unauthorized repairs performed on this equipment may result in danger to the technician or machine operator and will invalidate your factory warranty. For your safety and to avoid electrical shock, please observe all safety notes and precautions detailed throughout this manual.

If for any reason you do not understand the test procedures or are unable to perform the test/repairs safely, contact the Lincoln Electric Service Department for electrical troubleshooting assistance before you proceed. Call 216-383-2531 or 1-800-833-9353 (WELD).

TEST DESCRIPTION

This test will determine if the correct voltages are being supplied to the control PC board and if the board is generating the proper signals.

MATERIALS NEEDED

- Volt/Ohmmeter (Analog meter recommended)
- 5/16" Nut driver
- Control PC Board Schematic [G2512] (located in the Electrical Diagrams section of this manual)
- Control PC Board Voltage Test Points Chart

SQUARE WAVE TIG 355



Return to Section TOC
Return to Master TOC
Return to Section TOC
Return to Master TOC
Return to Section TOC
Return to Master TOC
Return to Section TOC
Return to Master TOC

TROUBLESHOOTING & REPAIR

CONTROL PC BOARD TEST *(continued)*

FIGURE F.15 – CONTROL PC BOARD LOCATION

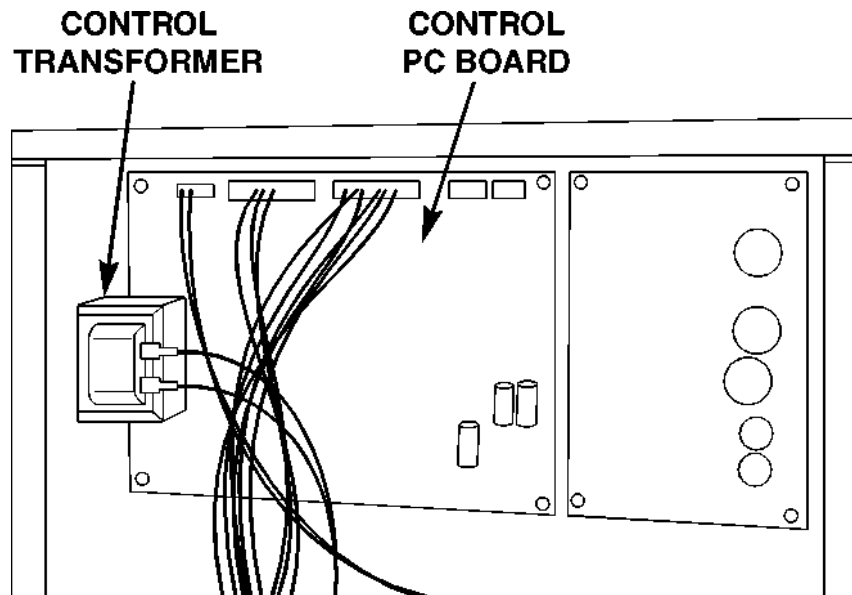

TEST PROCEDURE

1. Remove input power to the machine.
2. With the 5/16" nut driver, remove the screws and carefully lower the case front control panel.
3. Locate the test points on the control PC board that are called out in the Control PC Board Voltage Test Points Chart. See Figure F.15 and the Control PC Board Schematic.
4. Connect the DC voltmeter to the test points.



WARNING

ELECTRIC SHOCK can kill.



- With input power ON, there are high voltages inside the machine. Do not reach into the machine or touch any internal part of the machine while power is on.

5. Turn on input power to the machine.

SQUARE WAVE TIG 355



TROUBLESHOOTING & REPAIR

CONTROL PC BOARD TEST (continued)

FIGURE F.16 – CONTROL PC BOARD PLUG DETAILS

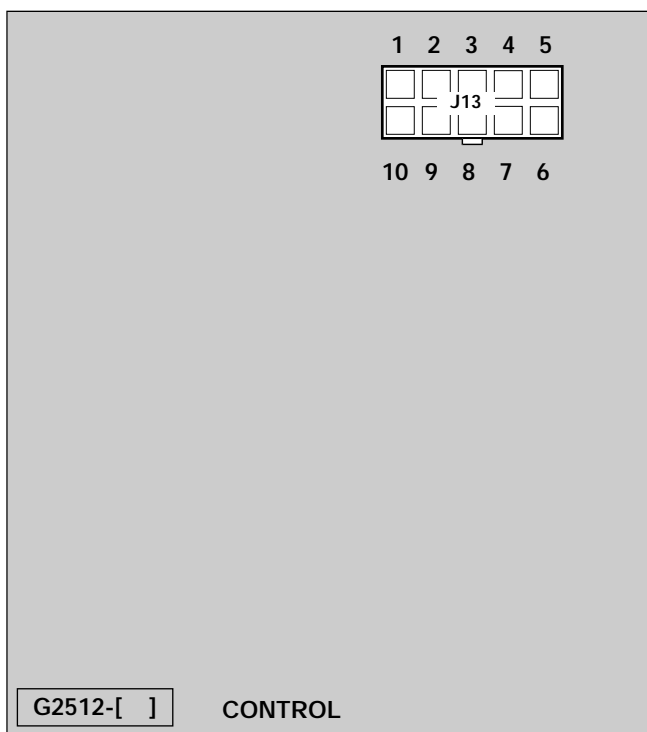

PLUG J13 LOCATION

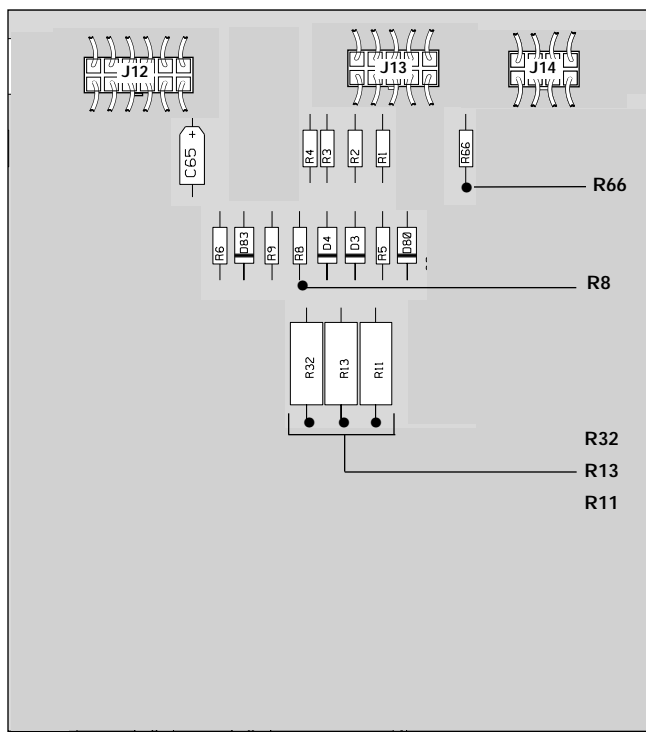

RESISTOR TEST POINTS
(Control Board Area Enlarged)

6. Check the test points for the appropriate voltages. See Figure F.16.
 - If the correct voltages are applied to the control PC board and the correct voltage signals are NOT being generated by the control PC board, the control PC board may be faulty.
 - If the correct voltages are NOT being applied to the control PC board, the power PC board or the control transformer may be faulty.
7. After the tests are completed and the problem repaired, install the front control panel, using the 5/16" nut driver.

SQUARE WAVE TIG 355



Return to Section TOC
Return to Master TOC
Return to Section TOC
Return to Master TOC
Return to Section TOC
Return to Master TOC
Return to Section TOC
Return to Master TOC

TROUBLESHOOTING & REPAIR

CONTROL PC BOARD TEST (continued)

CONTROL PC BOARD VOLTAGE TEST POINTS CHART

Test Points	Signals Being Checked	Expected Reading	Special Conditions for Test
3J13 to 5J13	Regulated +15VDC supply to control board	+15VDC	None
4J13 to 5J13	Regulated -15VDC supply to control board	-15VDC	None
1J13 to 2J13	Unregulated DC supply to control board	+12VDC	None
R11 to 5J13	Low logic signal for gas/water valve	0 - 2 VDC	TIG Mode Arc Start Switch or Amptrol must be activated
R32 to 5J13	Low logic signal for interlock control	0 - 2 VDC	If input contactor is staying closed signal will normally be low.
R13 to 5J13	Low logic signal for high frequency	0 - 2 VDC	CAUTION: High frequency may damage test equipment. Use analog volt/ohmmeter TIG Mode High frequency is active after gas preflow time.
R66 to 5J13	Low logic signal for DC OCV Boost (CR3) relay	0 - 2 VDC	StickMode DC Mode
R8 to 5J13	Low logic signal for AC OCV Boost (CR2) relay	0 - 2 VDC	Stick Mode AC Mode

SQUARE WAVE TIG 355



TROUBLESHOOTING & REPAIR

STATIC SCR TEST

WARNING

Service and repair should be performed by only Lincoln Electric factory trained personnel. Unauthorized repairs performed on this equipment may result in danger to the technician or machine operator and will invalidate your factory warranty. For your safety and to avoid electrical shock, please observe all safety notes and precautions detailed throughout this manual.

If for any reason you do not understand the test procedures or are unable to perform the test/repairs safely, contact the Lincoln Electric Service Department for electrical troubleshooting assistance before you proceed. Call 216-383-2531 or 1-800-833-9353 (WELD).

TEST DESCRIPTION

The Static SCR Test is a quick check to determine if an SCR is shorted or "leaky." See the machine waveform section for normal and abnormal SCR waveforms.

MATERIALS NEEDED

- Analog ohmmeter (Multimeter)
- 5/16" Nut driver
- Machine Wiring Diagrams (See the Electrical Diagrams section of this manual.)
- SCR Test Points drawing, Figure F.18.

SQUARE WAVE TIG 355



TROUBLESHOOTING & REPAIR

STATIC SCR TEST (continued)

FIGURE F.17 – POWER PC BOARD PLUG LOCATIONS

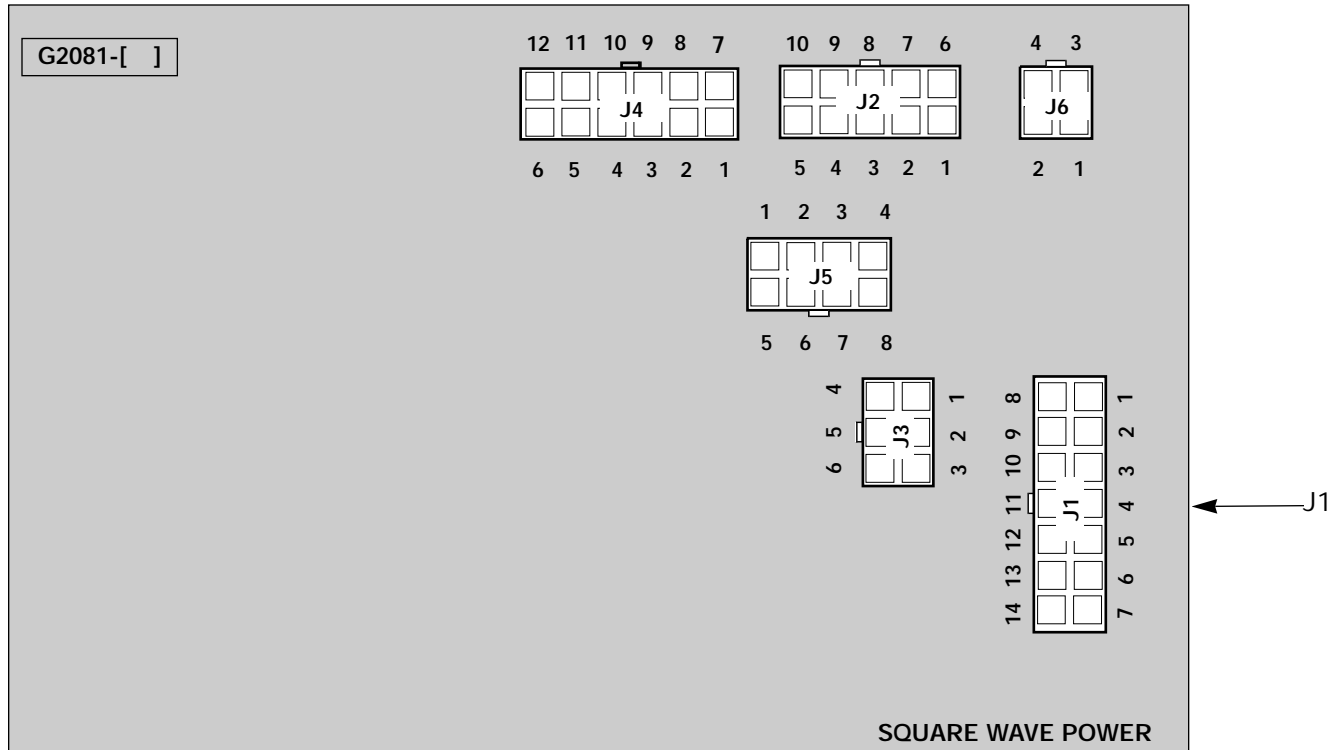

TEST PROCEDURE

1. Remove the input power to the machine.
 2. With the 5/16" nut driver, remove the machine case top and sides.
 3. Perform the Input Power Factor Capacitor Voltage Check and Discharge procedure.
 4. Remove the output welding cables from the machine.
 5. Remove plug J1 from the power PC board. Refer to Figure F.17.
 6. Place the polarity switch (S1) in a "DC" position.
 7. Remove the red insulating paint from heat sink test points. See Figure F.18. DO NOT DISASSEMBLE THE HEAT SINKS.
 8. With the 1/2" wrench, remove the choke lead from the negative plate (top).
 9. With the analog ohmmeter, test the resistance from anode to cathode of SCR1. Reverse the meter leads and check from cathode to anode of SCR1.
 - A. If a low resistance is indicated in either direction, SCR1 is faulty. Replace the SCR.
 10. Repeat Step 9 testing SCR2, SCR3, and SCR4.
- To further check SCR functions, use an SCR tester and proceed to the Active SCR test.

SQUARE WAVE TIG 355



TROUBLESHOOTING & REPAIR

STATIC SCR TEST (continued)

FIGURE F.18 - SCR TEST POINTS

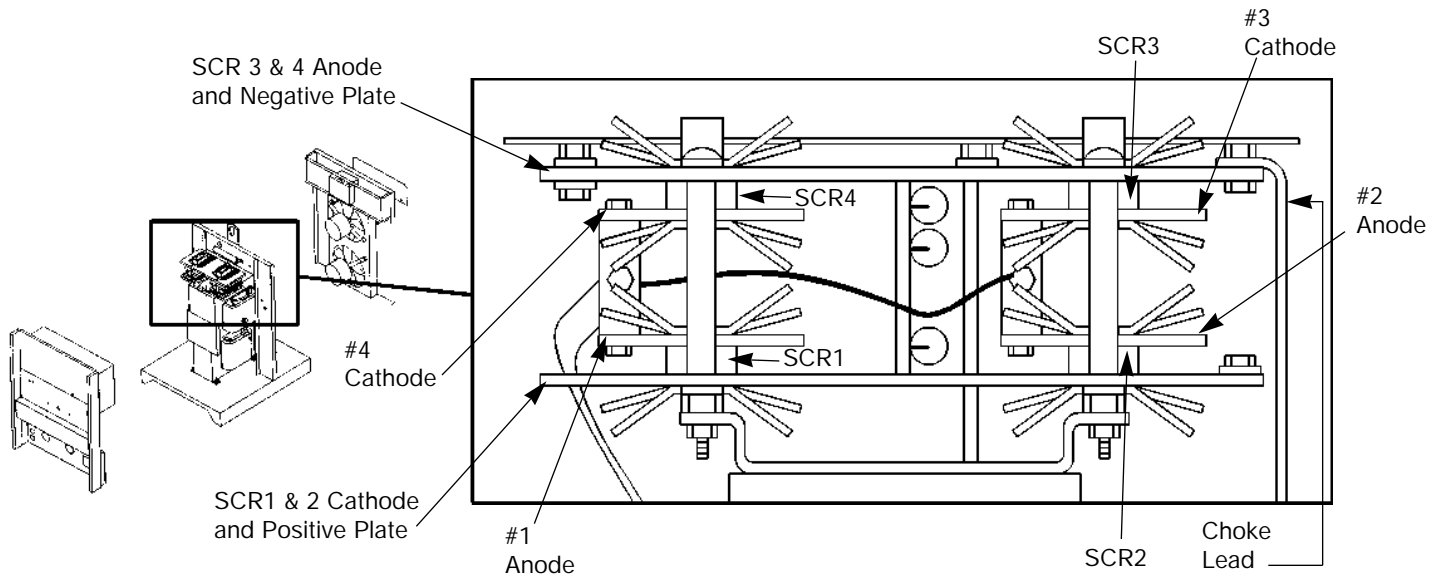

SQUARE WAVE TIG 355



Return to Section TOC

Return to Master TOC

Return to Section TOC

Return to Master TOC

Return to Section TOC

Return to Master TOC

Return to Section TOC

Return to Master TOC

TROUBLESHOOTING & REPAIR

ACTIVE SCR TEST

WARNING

Service and repair should be performed by only Lincoln Electric factory trained personnel. Unauthorized repairs performed on this equipment may result in danger to the technician or machine operator and will invalidate your factory warranty. For your safety and to avoid electrical shock, please observe all safety notes and precautions detailed throughout this manual.

If for any reason you do not understand the test procedures or are unable to perform the test/repairs safely, contact the Lincoln Electric Service Department for electrical troubleshooting assistance before you proceed. Call 216-383-2531 or 1-800-833-9353 (WELD).

TEST DESCRIPTION

The Active SCR Test will determine if the device is able to be gated "ON" and conduct current from anode to cathode.

MATERIALS NEEDED

- An SCR tester as outlined in this procedure
- 5/16" Nut driver
- Machine Wiring Diagrams (See Electrical Diagrams section of this manual.)
- SCR Test Points drawing, Figure F.20.

SQUARE WAVE TIG 355



TROUBLESHOOTING & REPAIR

ACTIVE SCR TEST (continued)

FIGURE F.19 - POWER BOARD PLUG LOCATIONS

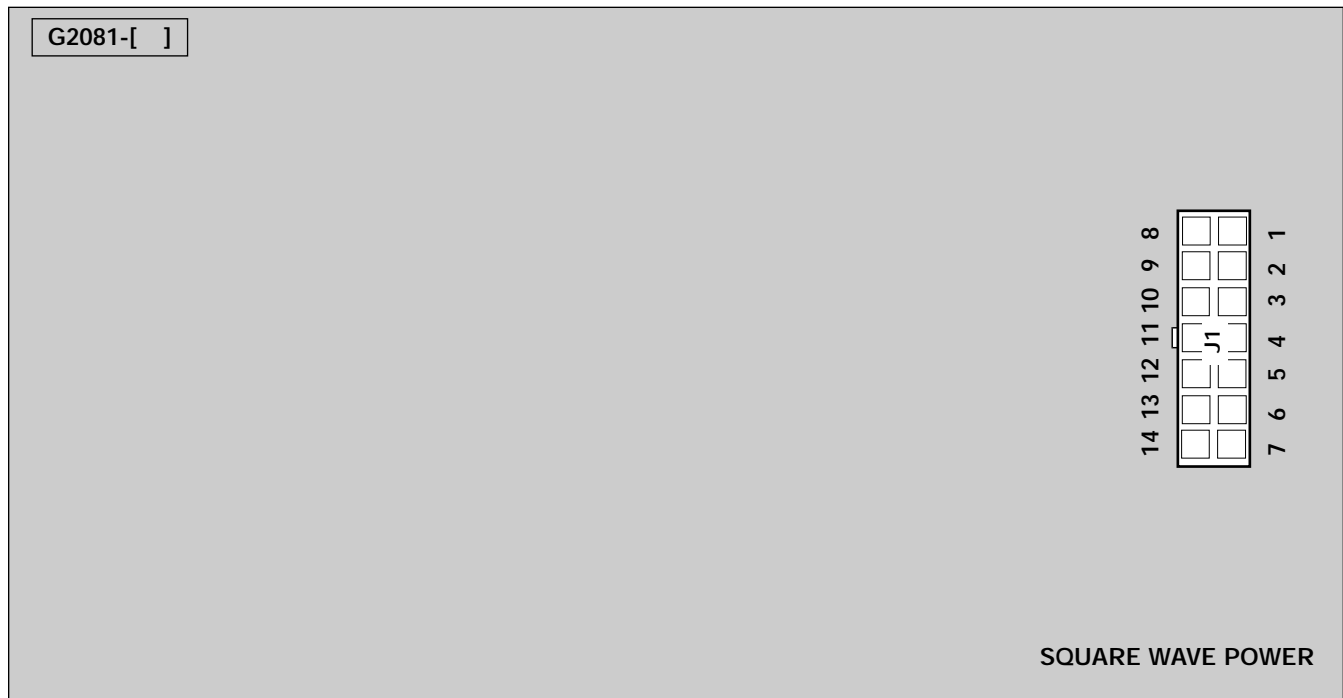

TEST PROCEDURE

1. Remove the input power to the machine.
2. With the 5/16" nut driver, remove the machine case top and sides.
3. Perform the Input Power Factor Capacitor Voltage Check and Discharge procedure.
4. Remove the output welding cables from the machine.
5. Remove plug J1 from the power PC board. See Figure F.19.
6. Place the polarity switch (S1) in a "DC" position.
7. Remove the red insulating paint from heat sink test points. See Figure F.20. DO NOT DISASSEMBLE THE HEAT SINKS.
8. With the 1/2" wrench, remove the choke lead from the negative plate (top).
9. Perform the test procedure as outlined in Figure F.21. Repeat the test for all four SCRs.
10. Replace any SCR or SCR assembly that does not pass the test in Step 9.

SQUARE WAVE TIG 355



TROUBLESHOOTING & REPAIR

ACTIVE SCR TEST (continued)

FIGURE F.20 - SCR TEST POINTS

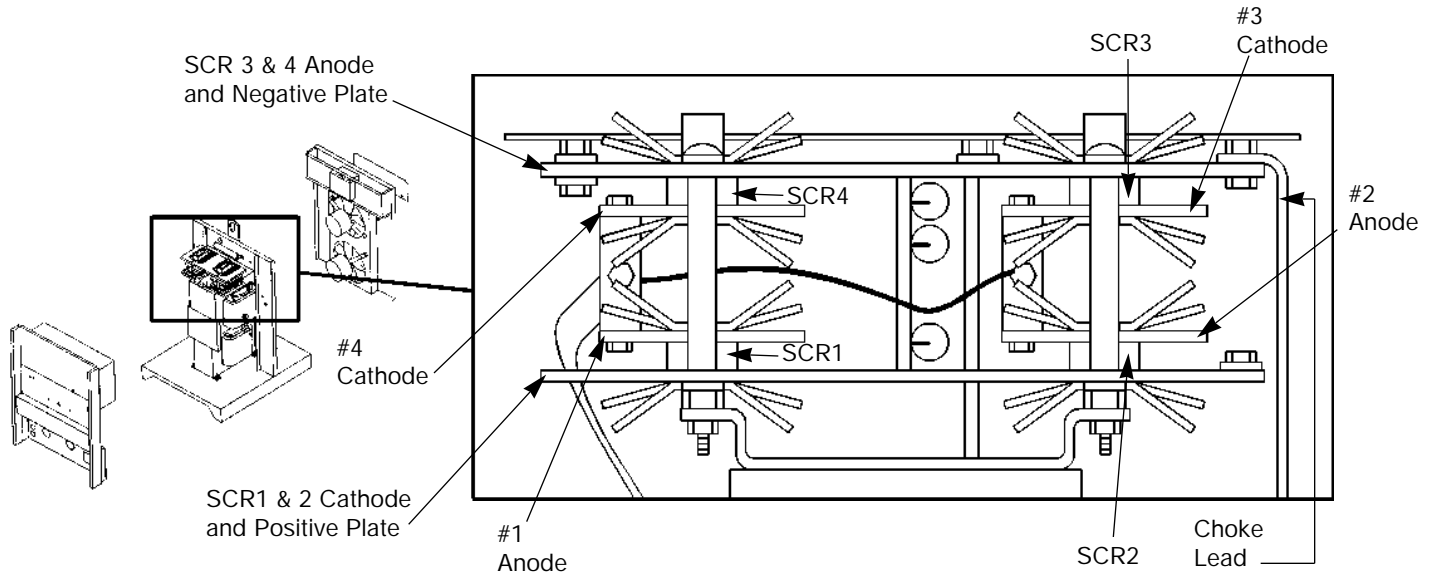

Return to Section TOC
 Return to Master TOC
 Return to Section TOC
 Return to Master TOC
 Return to Section TOC
 Return to Master TOC
 Return to Section TOC
 Return to Master TOC

SQUARE WAVE TIG 355



TROUBLESHOOTING & REPAIR

ACTIVE SCR TEST (continued)

FIGURE F.21 - SILICON CONTROLLED RECTIFIER TEST SETUP.

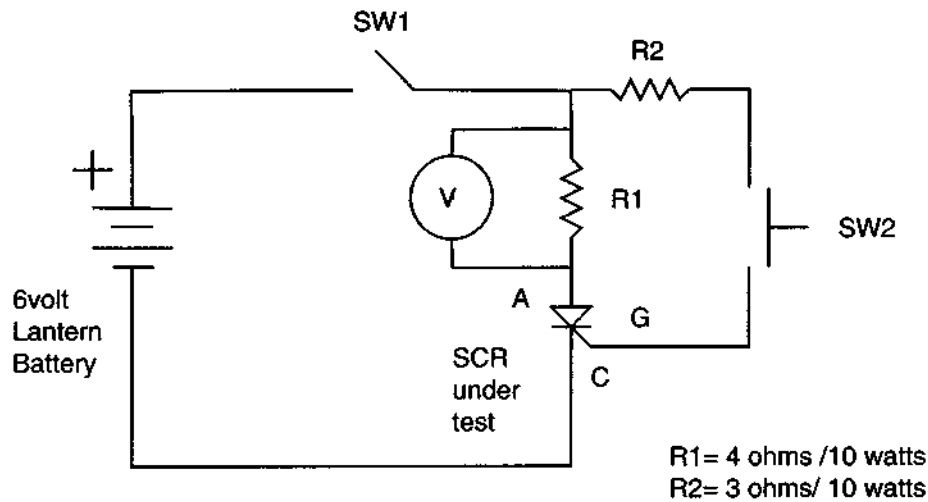

To test SCRs construct the circuit outlined above. Resistor values are plus or minus ten percent. The voltmeter scale should be low, approximately 0-5 or 0-10 volts DC.

SILICON CONTROLLED RECTIFIER TEST

(Heat Sink Mounted Units)

To test the SCRs, construct the circuit outlined in Figure F.21. One 6V lantern battery can be used. Resistor tolerances are 10%. The voltmeter scale should be low, approximately 0-5 or 0-10 volts.

BATTERY TEST

Check the battery by shorting leads (A) and (C) and then close switch SW-1. Replace the battery if the voltage is less than 4.5 volts.

1. Connect the SCR into the test circuit as shown: (A) lead to anode, (C) lead to cathode, and (G) lead to the gate. NOTE: the gate leads are located in plug J1.
2. Close switch SW-1 (switch SW-2 should be open). The voltmeter should read zero. If the voltmeter reads higher than zero, the SCR is shorted.
3. With switch SW-1 closed, close switch SW-2 for two seconds and release. The voltmeter should read 3 to 6 volts before and after switch SW-2 is released. If the voltmeter does not read, or reads only while SW-2 is depressed, the SCR or battery is defective. (Repeat Battery Test Procedure)
4. Open switch SW-1, disconnect the gate lead (G), and reverse the (A) and (C) leads on the SCR. Close switch SW-1. The voltmeter should read zero. If the voltage is higher than zero, the SCR is shorted.

SQUARE WAVE TIG 355



TROUBLESHOOTING & REPAIR

NORMAL OPEN CIRCUIT VOLTAGE WAVEFORM

DC STICK MODE

⚠ CAUTION

- HIGH VOLTAGE / HIGH FREQUENCY can damage test equipment.**
- Perform all voltage and waveform checks with high frequency circuit OFF.

CH1

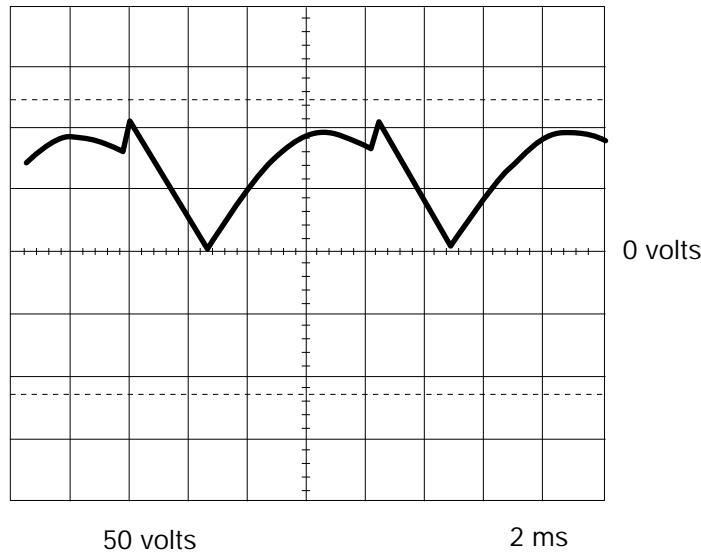

This is the typical DC (+) output voltage waveform generated from a properly operating machine. Note that each vertical division represents 50 volts and that each horizontal division represents 2 milliseconds in time.

Note: Scope probes connected at machine output terminals: (+) probe to electrode terminal, (-) probe to work terminal.

SCOPE SETTINGS

Volts/Div.....	50V/Div.
Horizontal Sweep.....	2 ms/Div.
Coupling	DC
Trigger	Internal

SQUARE WAVE TIG 355



TROUBLESHOOTING & REPAIR

NORMAL OPEN CIRCUIT VOLTAGE WAVEFORM

AC STICK MODE

⚠ CAUTION

- HIGH VOLTAGE / HIGH FREQUENCY can damage test equipment.**
- Perform all voltage and waveform checks with high frequency circuit OFF.

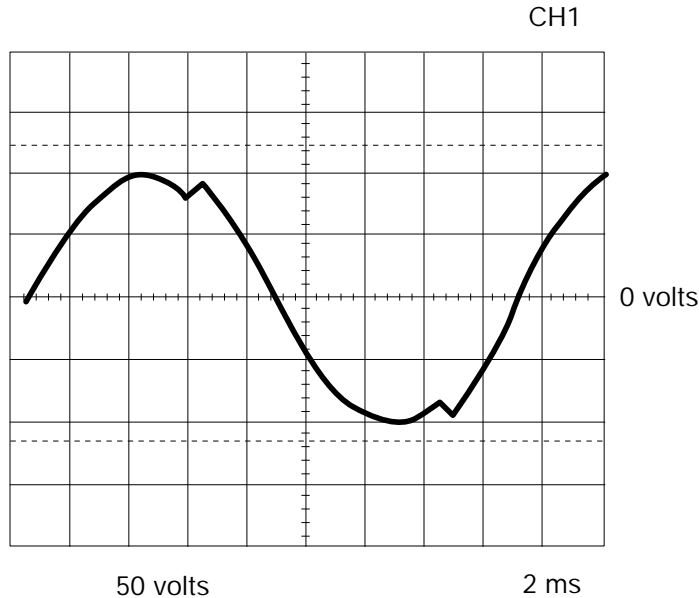

This is the typical AC output voltage waveform generated from a properly operating machine. Note that each vertical division represents 50 volts and that each horizontal division represents 2 milliseconds in time.

Note: Scope probes connected at machine output terminals: (+) probe to electrode terminal, (-) probe to work terminal.

SCOPE SETTINGS

Volts/Div.....	50V/Div.
Horizontal Sweep.....	2 ms/Div.
Coupling	DC
Trigger	Internal

SQUARE WAVE TIG 355



Return to Section TOC

Return to Section TOC

Return to Section TOC

Return to Section TOC

Return to Master TOC

Return to Master TOC

Return to Master TOC

Return to Master TOC

TROUBLESHOOTING & REPAIR

NORMAL OPEN CIRCUIT VOLTAGE WAVEFORM

AC TIG MODE

⚠ CAUTION

HIGH VOLTAGE / HIGH FREQUENCY can damage test equipment.

- Perform all voltage and waveform checks with high frequency circuit OFF.

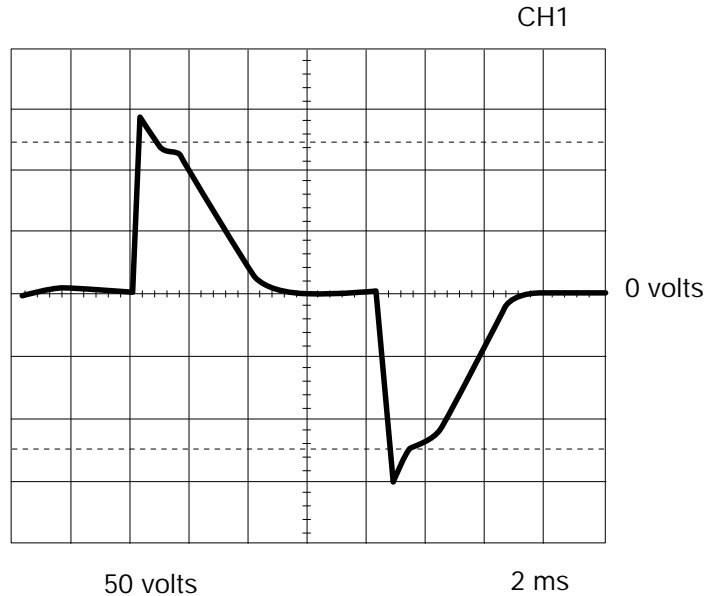

This is the typical AC output voltage waveform generated from a properly operating machine. Note that each vertical division represents 50 volts and that each horizontal division represents 2 milliseconds in time.

Note: Scope probes connected at machine output terminals: (+) probe to electrode terminal, (-) probe to work terminal.

SCOPE SETTINGS

Volts/Div	50V/Div.
Horizontal Sweep	2 ms/Div.
Coupling	DC
Trigger	Internal

SQUARE WAVE TIG 355



TROUBLESHOOTING & REPAIR

TYPICAL OUTPUT VOLTAGE WAVEFORM – MACHINE LOADED

DC TIG MODE

⚠ CAUTION

- HIGH VOLTAGE / HIGH FREQUENCY** can damage test equipment.
- Perform all voltage and waveform checks with high frequency circuit OFF.

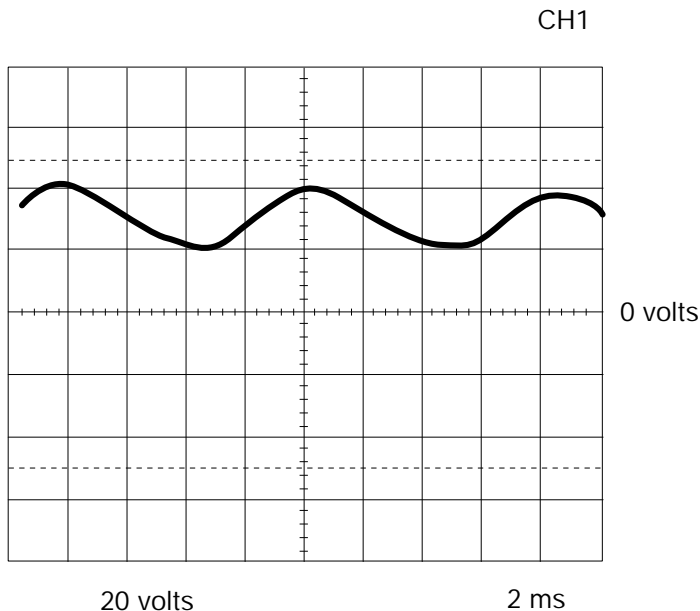

MACHINE LOADED TO 350 AMPS AT 34VDC

This is a typical DC (+) output voltage waveform generated from a properly operating machine. Note that each vertical division represents 20 volts and that each horizontal division represents 2 milliseconds in time. The machine was loaded with a resistance grid bank. The TIG 355 display read 350 amps at 34 VDC.

Note: Scope probes connected at machine output terminals: (+) probe to electrode terminal, (-) probe to work terminal.

SCOPE SETTINGS

Volts/Div	20V/Div.
Horizontal Sweep.....	2 ms/Div.
Coupling	DC
Trigger	Internal

SQUARE WAVE TIG 355



Return to Section TOC
Return to Master TOC

Return to Section TOC
Return to Master TOC

Return to Section TOC
Return to Master TOC

Return to Section TOC
Return to Master TOC

TROUBLESHOOTING & REPAIR

AC TIG MODE (BALANCED WAVEFORM)

⚠ CAUTION

- HIGH VOLTAGE / HIGH FREQUENCY** can damage test equipment.
- Perform all voltage and waveform checks with high frequency circuit OFF.

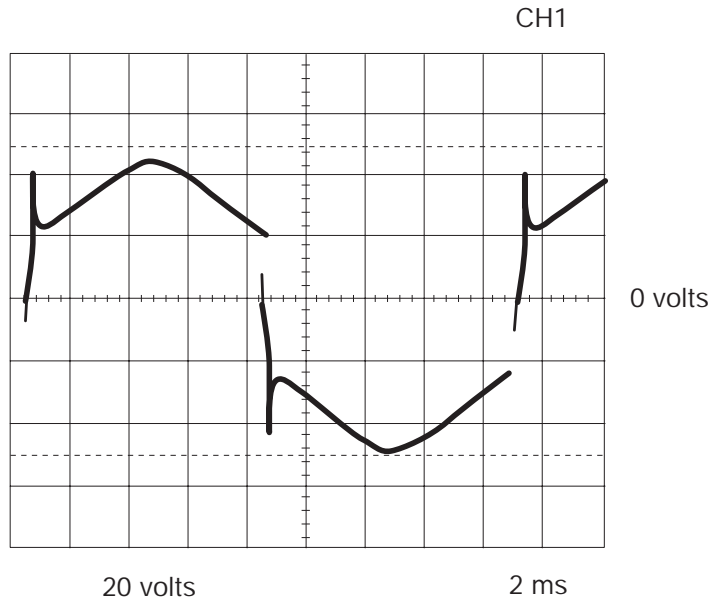

MACHINE LOADED TO 350 AMPS AT 34VAC

This is a typical AC output voltage waveform generated from a properly operating machine. Note that each vertical division represents 20 volts and that each horizontal division represents 2 milliseconds in time. The machine was loaded with a resistance grid bank. The TIG 355 display read 350 amps at 34 VAC.

Note: Scope probes connected at machine output terminals: (+) probe to electrode terminal, (-) probe to work terminal.

SCOPE SETTINGS

Volts/Div20V/Div.
 Horizontal Sweep.....2 ms/Div.
 CouplingDC
 TriggerInternal

SQUARE WAVE TIG 355



Return to Section TOC

Return to Section TOC

Return to Section TOC

Return to Section TOC

Return to Master TOC

Return to Master TOC

Return to Master TOC

Return to Master TOC

TROUBLESHOOTING & REPAIR

ABNORMAL OPEN CIRCUIT VOLTAGE – DC TIG MODE ONE OUTPUT SCR NOT FUNCTIONING

⚠ CAUTION

- HIGH VOLTAGE / HIGH FREQUENCY can damage test equipment.
- Perform all voltage and waveform checks with high frequency circuit OFF.

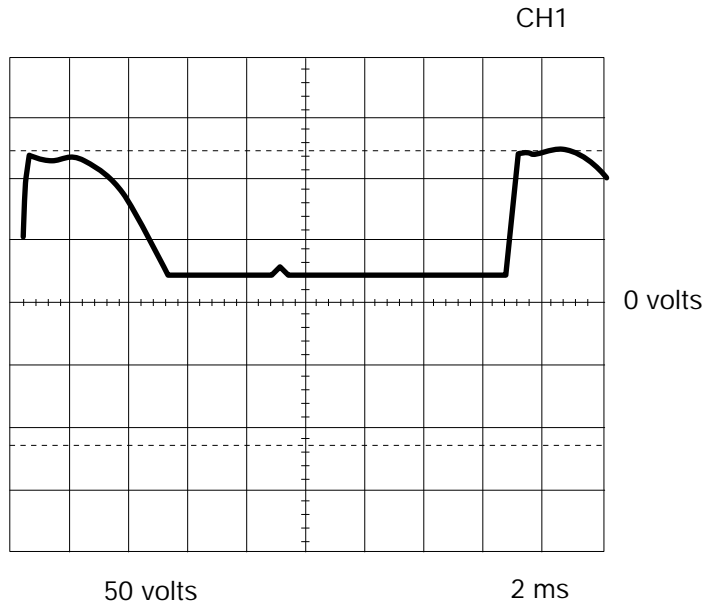

This is NOT the typical DC (+) output voltage waveform. One output SCR is not functioning. Note the “gap” in the waveform. One SCR gate was disconnected to simulate an open or non-functioning output SCR. Each vertical division represents 50 volts and each horizontal division represents 2 milliseconds in time.

Note: Scope probes connected at machine output terminals: (+) probe to electrode terminal, (-) probe to work terminal.

SCOPE SETTINGS

Volts/Div.....	50V/Div.
Horizontal Sweep.....	2 ms/Div.
Coupling	DC
Trigger	Internal

SQUARE WAVE TIG 355



Return to Section TOC
Return to Section TOC
Return to Section TOC
Return to Section TOC
Return to Section TOC

Return to Master TOC
Return to Master TOC
Return to Master TOC
Return to Master TOC
Return to Master TOC

TROUBLESHOOTING & REPAIR

ABNORMAL OPEN CIRCUIT VOLTAGE – AC TIG MODE

ONE OUTPUT SCR NOT FUNCTIONING

⚠ CAUTION

HIGH VOLTAGE / HIGH FREQUENCY can damage test equipment.

- Perform all voltage and waveform checks with high frequency circuit OFF.

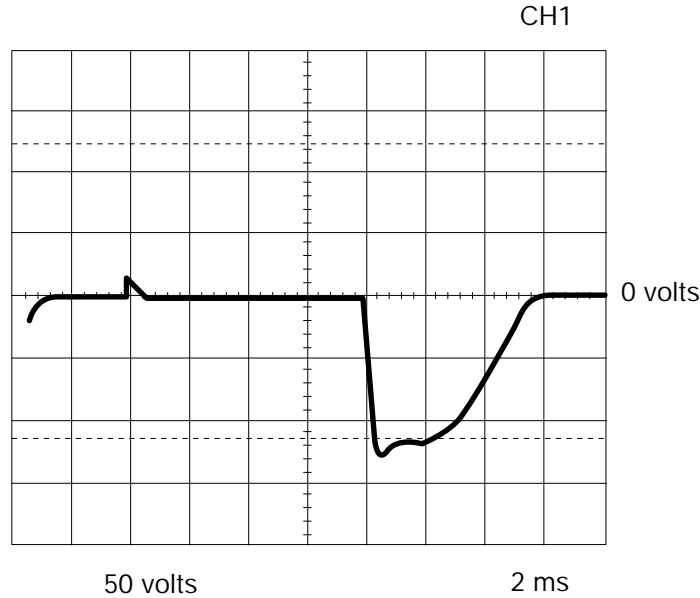

This is NOT the typical AC output voltage waveform. One output SCR is not functioning. Note the “gap” in the waveform. One SCR gate was disconnected to simulate an open or non-functioning output SCR. Each vertical division represents 50 volts and each horizontal division represents 2 milliseconds in time.

Note: Scope probes connected at machine output terminals: (+) probe to electrode terminal, (-) probe to work terminal.

SCOPE SETTINGS

Volts/Div.....50V/Div.
 Horizontal Sweep.....2 ms/Div.
 CouplingDC
 TriggerInternal

SQUARE WAVE TIG 355



Return to Section TOC

Return to Section TOC

Return to Section TOC

Return to Section TOC

Return to Master TOC

Return to Master TOC

Return to Master TOC

Return to Master TOC

TROUBLESHOOTING & REPAIR

CONTROL PC BOARD REMOVAL AND REPLACEMENT

⚠ WARNING

Service and repair should be performed by only Lincoln Electric factory trained personnel. Unauthorized repairs performed on this equipment may result in danger to the technician or machine operator and will invalidate your factory warranty. For your safety and to avoid electrical shock, please observe all safety notes and precautions detailed throughout this manual.

If for any reason you do not understand the test procedures or are unable to perform the test/repairs safely, contact the Lincoln Electric Service Department for electrical troubleshooting assistance before you proceed. Call 216-383-2531 or 1-800-833-9353 (WELD).

DESCRIPTION

The following procedure will aid the technician in removing the control PC board.

MATERIALS NEEDED

- 5/16" Nut driver
- Phillips head screw driver
- Static grounding wrist strap

SQUARE WAVE TIG 355



Return to Section TOC
Return to Master TOC
Return to Section TOC
Return to Master TOC
Return to Section TOC
Return to Master TOC
Return to Section TOC
Return to Master TOC

TROUBLESHOOTING & REPAIR

CONTROL PC BOARD REMOVAL AND REPLACEMENT *(continued)*

FIGURE F.22 - CONTROL PC BOARD

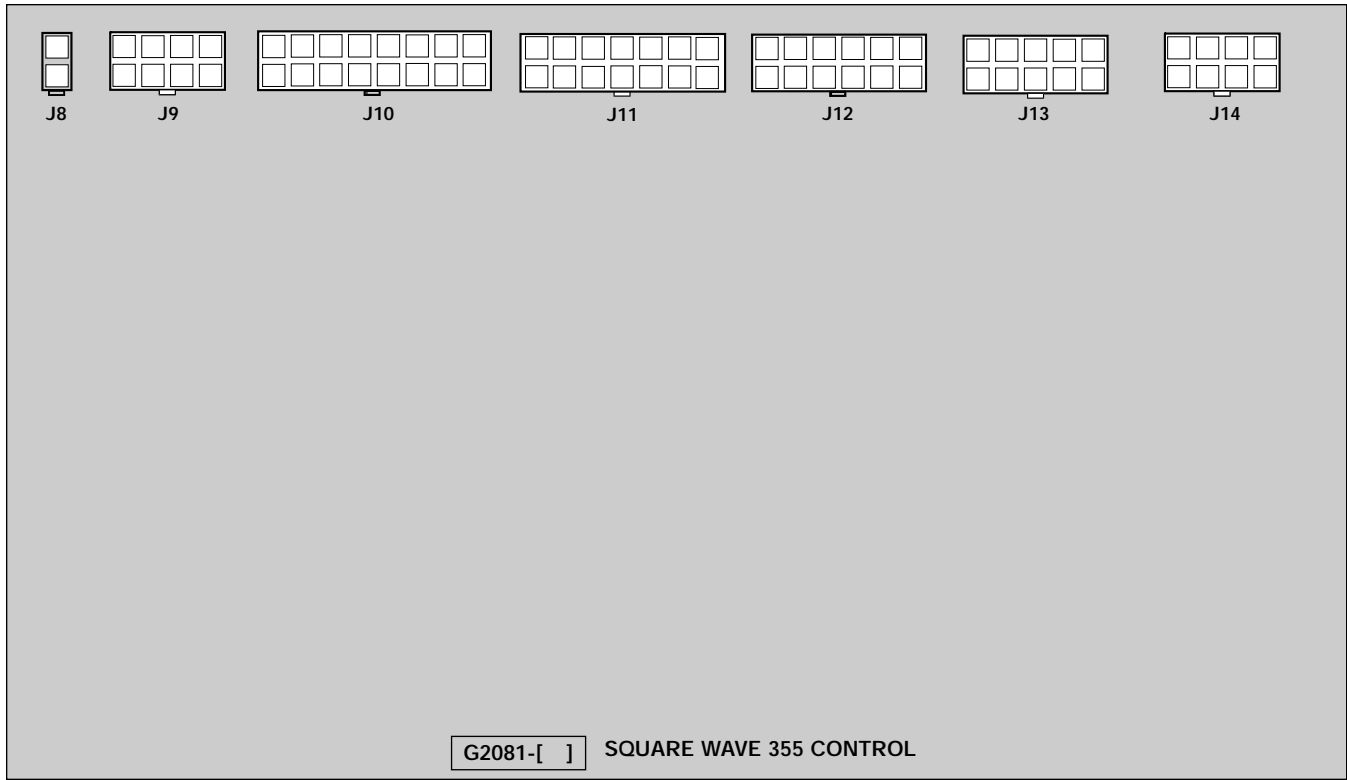

TEST PROCEDURE

Before starting the following procedure, refer to the topic "PC Board Troubleshooting Procedures" at the beginning of this section.

1. Remove input power to the machine.
2. With the 5/16" nut driver, remove the sheet metal screws that hold the front control panel in place. Carefully lower the panel.
3. Carefully remove the molex type plugs connected to the control PC board. See Figure F.22.
4. With the phillips head screw driver, remove the mounting screws from the control PC board.
5. Carefully remove the control PC board. Be sure to observe static electricity cautions.



CAUTION

Be sure to follow the recommended static-free methods for handling printed circuit boards. Failure to do so can result in permanent damage to the equipment.

6. Replace the old control PC board. Mount the board with the mounting screws and phillips head screw driver.
7. Carefully install the molex plugs that connect to the control PC board.
8. Replace the front control panel and tighten the sheet metal screws with the 5/16" nut driver.

SQUARE WAVE TIG 355



TROUBLESHOOTING & REPAIR

POWER PC BOARD REMOVAL AND REPLACEMENT

⚠ WARNING

Service and repair should be performed by only Lincoln Electric factory trained personnel. Unauthorized repairs performed on this equipment may result in danger to the technician or machine operator and will invalidate your factory warranty. For your safety and to avoid electrical shock, please observe all safety notes and precautions detailed throughout this manual.

If for any reason you do not understand the test procedures or are unable to perform the test/repairs safely, contact the Lincoln Electric Service Department for electrical troubleshooting assistance before you proceed. Call 216-383-2531 or 1-800-833-9353 (WELD).

DESCRIPTION

The following procedure will aid the technician in removing the power PC board.

MATERIALS NEEDED

- 5/16" Nut driver
- Phillips head screw driver
- Static grounding wrist strap

SQUARE WAVE TIG 355



TROUBLESHOOTING & REPAIR

POWER PC BOARD REMOVAL AND REPLACEMENT (continued)

FIGURE F.23 - POWER PC BOARD

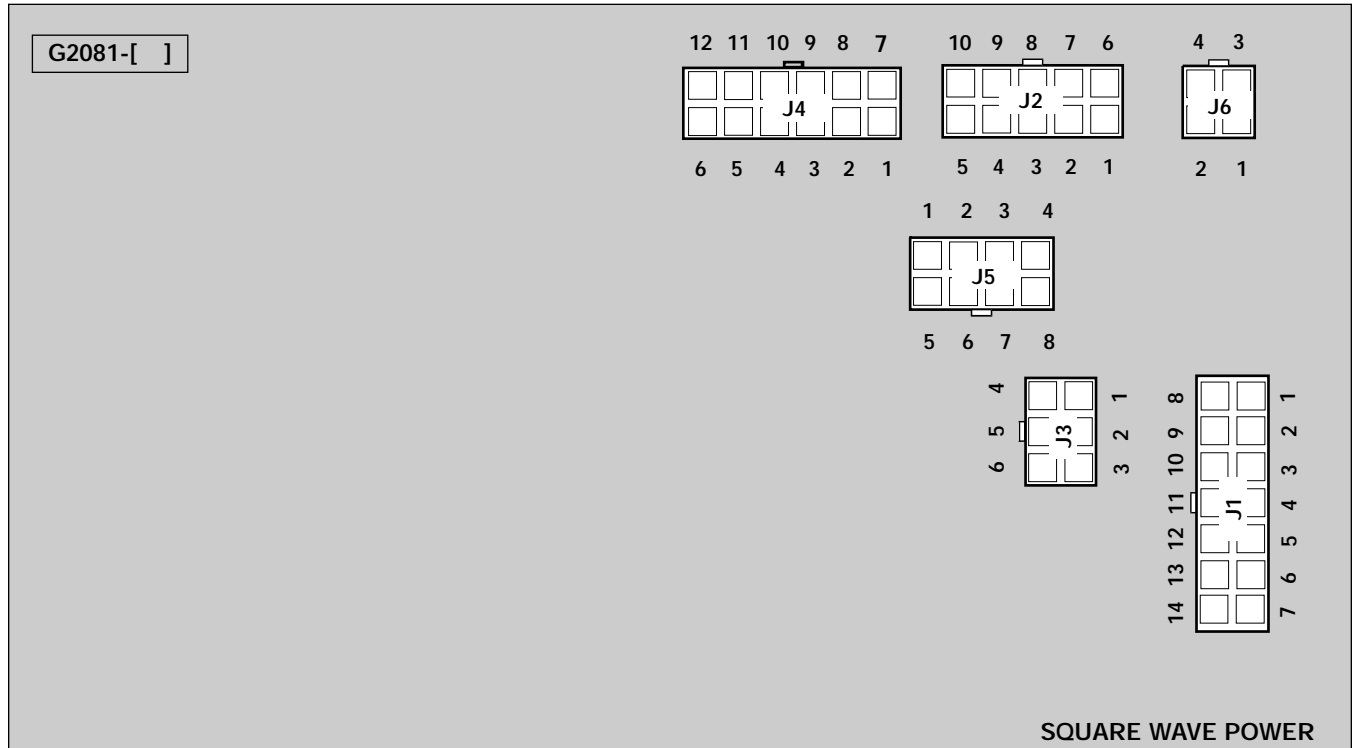

PROCEDURE

Before starting the following procedure, refer to the topic "PC Board Troubleshooting Procedures" at the beginning of this section.

1. Remove input power to the machine.
2. With the 5/16" nut driver, remove the sheet metal screws that hold the front control panel in place. Carefully lower the panel.
3. Carefully remove the 6 molex type plugs connected to the power PC board. See Figure F.23.
4. With the phillips head screw driver, remove the 6 mounting screws from the power PC board.
5. Carefully remove the power PC board. Be sure to observe static electricity cautions.

⚠ CAUTION

Be sure to follow the recommended static-free methods for handling printed circuit boards. Failure to do so can result in permanent damage to the equipment.

6. Replace the old power PC board. Mount the board with the 6 mounting screws and phillips head screw driver.
7. Carefully install the 6 molex plugs that connect to the power PC board.
8. Replace the front control panel and tighten the sheet metal screws with the 5/16" nut driver.

SQUARE WAVE TIG 355



TROUBLESHOOTING & REPAIR

INPUT CONTACTOR REMOVAL AND REPLACEMENT

⚠ WARNING

Service and repair should be performed by only Lincoln Electric factory trained personnel. Unauthorized repairs performed on this equipment may result in danger to the technician or machine operator and will invalidate your factory warranty. For your safety and to avoid electrical shock, please observe all safety notes and precautions detailed throughout this manual.

If for any reason you do not understand the test procedures or are unable to perform the test/repairs safely, contact the Lincoln Electric Service Department for electrical troubleshooting assistance before you proceed. Call 216-383-2531 or 1-800-833-9353 (WELD).

DESCRIPTION

The following procedure will aid the technician in removing the input contactor (C1) for maintenance or replacement.

MATERIALS NEEDED

- 5/16" Nut driver
- Slot head screw driver

SQUARE WAVE TIG 355



TROUBLESHOOTING & REPAIR

INPUT CONTACTOR REMOVAL AND REPLACEMENT *(continued)*

FIGURE F.24 – INPUT CONTACTOR CONNECTIONS

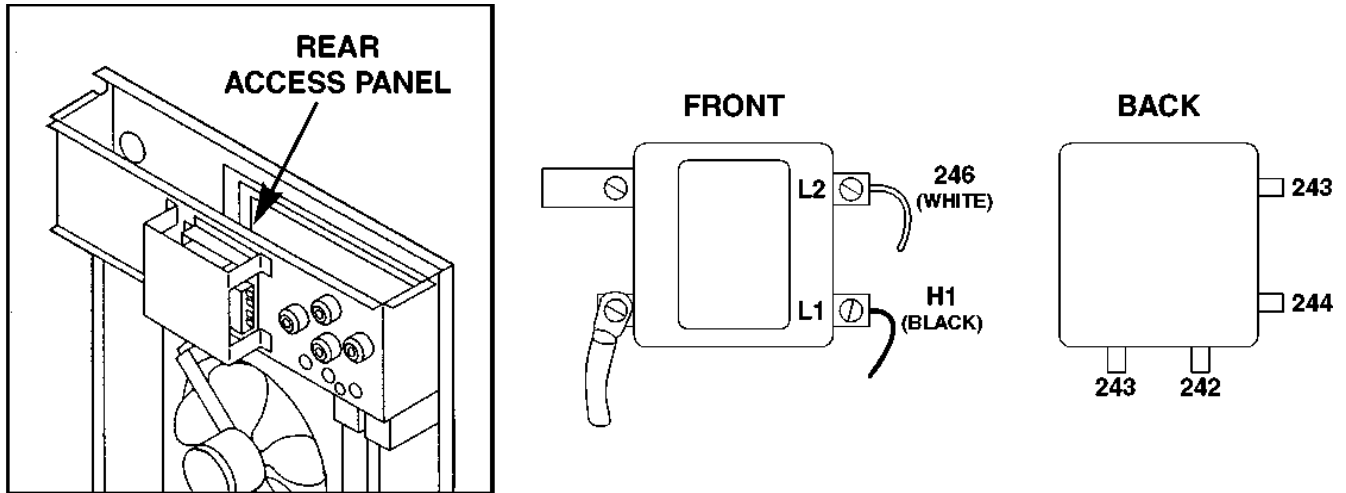

PROCEDURE

1. Remove input power to the machine.
 2. With the 5/16" nut driver, remove the case top and sides.
 3. Perform the Input Power Factor Capacitor Voltage Check.
 4. With the 5/16" nut driver, remove the rear access panel.
- For Steps 5-20, refer to Figure F.24.
5. With the slot head screw driver, remove the input leads from the L1 and L2 terminals on the input contactor.
 6. With the slot head screw driver, remove the copper strap, the heavy lead, and the small capacitors from the output side of the contactor.
 7. Remove small lead H1 from the L1 terminal.
 8. Remove small lead #246 from the L2 terminal.
 9. Remove leads #243 and #244 from the contactor coil tabs.
 10. Remove leads #243 and #242 from the contactor interlock located on the bottom of the contactor.
 11. With the 5/16" nut driver, remove the 4 screws mounting the contactor bracket to the case back.
 12. Carefully remove the contactor and the bracket assembly from the case back.

SQUARE WAVE TIG 355



TROUBLESHOOTING & REPAIR

INPUT CONTACTOR REMOVAL AND REPLACEMENT *(continued)*

13. Replacement: Mount the contactor bracket assembly to the case back and attach it with the 4 mounting screws. Use the 5/16" nut driver.
14. Attach leads #243 and #242 to the contactor interlock located on the bottom of the contactor.
15. Attach leads #243 and #244 to the contactor coil tabs.
16. Attach small lead #246 to the L2 terminal.
17. Attach small lead H1 to the L1 terminal.
18. With the slot head screw driver, attach the copper strap, the heavy lead, and the small capacitors to the output side of the contactor.
19. With the slot head screw driver, attach the input leads to the L1 and L2 terminals on the input contactor.
20. With the 5/16" nut driver, install the rear access panel, case sides and top.

Return to Section TOC
Return to Master TOC

Return to Section TOC
Return to Master TOC

Return to Section TOC
Return to Master TOC

Return to Section TOC
Return to Master TOC

SQUARE WAVE TIG 355



TROUBLESHOOTING & REPAIR

FAN MOTOR AND BLADE REMOVAL AND REPLACEMENT

⚠ WARNING

Service and repair should be performed by only Lincoln Electric factory trained personnel. Unauthorized repairs performed on this equipment may result in danger to the technician or machine operator and will invalidate your factory warranty. For your safety and to avoid electrical shock, please observe all safety notes and precautions detailed throughout this manual.

If for any reason you do not understand the test procedures or are unable to perform the test/repairs safely, contact the Lincoln Electric Service Department for electrical troubleshooting assistance before you proceed. Call 216-383-2531 or 1-800-833-9353 (WELD).

DESCRIPTION

The following procedure will aid the technician in accessing and removing the fan motors and blades for maintenance or replacement.

MATERIALS NEEDED

- 5/16" Nut driver
- 1/4" Nut driver
- 11/32" Wrench
- Diagonal cutters

SQUARE WAVE TIG 355



Return to Section TOC
Return to Master TOC
Return to Section TOC
Return to Master TOC
Return to Section TOC
Return to Master TOC
Return to Section TOC
Return to Master TOC

TROUBLESHOOTING & REPAIR

FAN MOTOR AND BLADE REMOVAL AND REPLACEMENT *(continued)*

FIGURE F.25- FAN MOTOR AND BLADE MOUNTING DETAILS

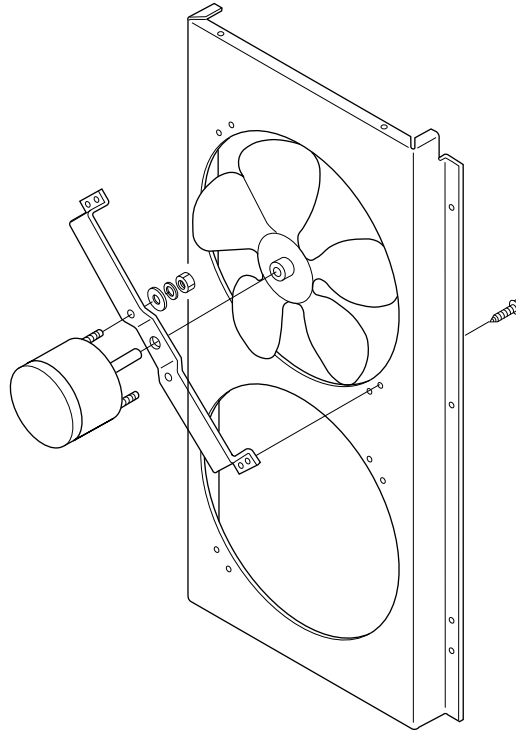

PROCEDURE

The following procedure allows you to remove and replace either of the two fans on the Square Wave TIG 355.

1. Remove the input power to the machine.
 2. With the 5/16" nut driver, remove the case top and sides.
 3. Perform the Input Power Factor Capacitor Voltage Check.
- For Steps 4-11, refer to Figure F.25.
4. With the 1/4" nut driver, loosen the fan blade clamp and slide the blade from the motor shaft. Note blade placement on the shaft for reassembly.
 5. With the 11/32" wrench, remove the nuts, lock washers, and flat washers that mount the fan motor to the fan bracket.
 6. Cut any cable ties or wire leads.
 7. Carefully remove the fan motor from the fan bracket.

NOTE: You may have to loosen or remove the bottom case back screws to gain enough clearance to remove the motor.

8. Replacement: Mount the fan motor to the fan bracket with the flat washers, lock washers, and nuts removed earlier. Use the 11/32" wrench.
9. Slide the fan blade onto the fan motor shaft. Note its proper placement. With the 1/4" nut driver, tighten the fan blade clamp.
10. Splice or resolder any wires cut during removal. Insulate connectors. Replace cable ties as necessary.
11. With the 5/16" nut driver, install the case top and sides.

SQUARE WAVE TIG 355



[Return to Section TOC](#) [Return to Master TOC](#)

TROUBLESHOOTING & REPAIR

OUTPUT RECTIFIER REMOVAL AND REPLACEMENT

⚠ WARNING

Service and repair should be performed by only Lincoln Electric factory trained personnel. Unauthorized repairs performed on this equipment may result in danger to the technician or machine operator and will invalidate your factory warranty. For your safety and to avoid electrical shock, please observe all safety notes and precautions detailed throughout this manual.

If for any reason you do not understand the test procedures or are unable to perform the test/repairs safely, contact the Lincoln Electric Service Department for electrical troubleshooting assistance before you proceed. Call 216-383-2531 or 1-800-833-9353 (WELD).

DESCRIPTION

The following procedure will aid the technician in removing the output rectifier for maintenance or replacement.

MATERIALS NEEDED

- 5/16" Nut driver
- 1/2" Wrench
- 7/16" Wrench
- Diagonal cutters

SQUARE WAVE TIG 355



TROUBLESHOOTING & REPAIR

OUTPUT RECTIFIER REMOVAL AND REPLACEMENT (continued)

FIGURE F.26 - OUTPUT RECTIFIER CONNECTION DETAILS

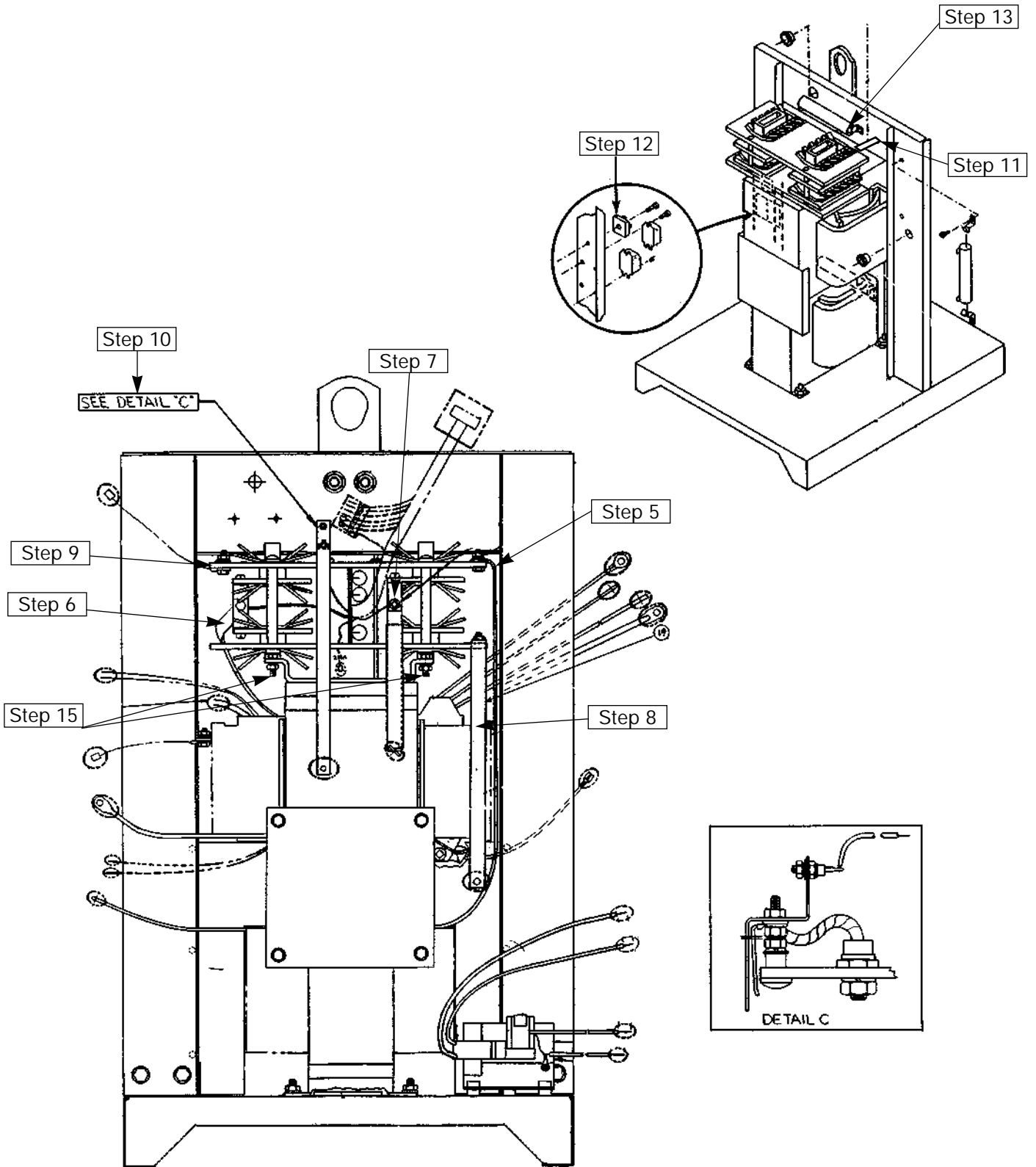

SQUARE WAVE TIG 355



Return to Section TOC
Return to Master TOC
Return to Section TOC
Return to Master TOC
Return to Section TOC
Return to Master TOC
Return to Section TOC
Return to Master TOC

TROUBLESHOOTING & REPAIR

OUTPUT RECTIFIER REMOVAL AND REPLACEMENT *(continued)*

PROCEDURE

1. Remove input power to the machine.
 2. With the 5/16" nut driver, remove the case top and sides.
 3. Perform the Input Power Factor Capacitor Voltage Check.
- For Steps 4-27, refer to Figure F.26.
4. Remove plug J1 from the power PC board.
 5. With the 1/2" wrench, remove the choke lead from the negative plate.
 6. With the 1/2" wrench, remove the X1 lead from SCR1 - SCR4 junction. Note lead placement for reassembly: X1 is sandwiched between the two leads from the output rectifier bridge.
 7. With the 1/2" wrench, remove the lead at the SCR2 - SCR3 junction leading to the polarity switch (S1). Note lead placement for reassembly.
 8. With the 1/2" wrench, remove the lead from the positive plate leading to the polarity switch (S1).
 9. With the 7/16" wrench, remove the small lead from the negative plate leading to CR3 relay.
 10. With the 7/16" wrench, remove D1, D2 and the copper strap lead assembly from the insulated stud on the negative plate.
 11. Remove leads #215 and #264 from the R7 resistor.
 12. Remove leads #213 and #214/214A from the background rectifier. Separate leads #214 and #214A and pull them through. Cut any necessary cable ties.
 13. Remove (cut or unsolder) lead #212 from the R3 resistor.
 14. Remove leads #210 and #211 from plug J1 (Located at power board. See wiring diagram). Use a molex pin extractor. Note lead placement for reassembly.
 15. With the 7/16" wrench, remove the four nuts, lock washers, and two flat washers mounting the rectifier assembly to the main transformer iron. NOTE: The two flat washers are located on the right hand mounting screws.
 16. Carefully remove the rectifier, snubber, and torriod assembly.
 17. Reassembly: carefully mount the rectifier, snubber, and torriod assembly onto the main transformer iron. With the 7/16" wrench, fasten the assembly down with the flat washers, lock washers, and nuts. Note that the two flat washers are located on the the right hand mounting screws.
 18. Attach lead #212 to the R3 resistor. (Splice or solder the connection.)
 19. Route leads #213 and #214/214A and attach them to the background rectifier. Replace any necessary cable ties.
 20. Attach leads #215 and #264 to the R7 resistor.
 21. With the 7/16" wrench, attach D1, D2 and the copper strap lead assembly to the insulated stud on the negative plate. Attach the small lead from the CR3 relay to the negative plate.
 22. With the 1/2" wrench, attach the lead from the polarity switch (S1) to the positive plate.
 23. With the 1/2" wrench, attach the lead from the polarity switch (S1) at the SCR2 - SCR3 junction.
 24. With the 1/2" wrench, attach the X1 lead to the SCR1 - SCR4 junction. X1 is sandwiched between the two leads from the output rectifier bridge.
 25. With the 1/2" wrench, attach the choke lead to the negative plate.
 26. Attach plug J1 to the power PC board.
 27. With the 5/16" nut driver, install the case top and sides.

SQUARE WAVE TIG 355



TROUBLESHOOTING & REPAIR

SCR REMOVAL AND AND REPLACEMENT

⚠ WARNING

Service and repair should be performed by only Lincoln Electric factory trained personnel. Unauthorized repairs performed on this equipment may result in danger to the technician or machine operator and will invalidate your factory warranty. For your safety and to avoid electrical shock, please observe all safety notes and precautions detailed throughout this manual.

If for any reason you do not understand the test procedures or are unable to perform the test/repairs safely, contact the Lincoln Electric Service Department for electrical troubleshooting assistance before you proceed. Call 216-383-2531 or 1-800-833-9353 (WELD).

DESCRIPTION

The following procedure will aid the technician in removing the SCRs from the output rectifier heat sink assembly for maintenance or replacement.

MATERIALS NEEDED

- 5/16" nut driver
- 1/2" Wrench
- 7/16" Wrench
- Diagonal cutters
- 1/4" socket or box end wrench
- Putty knife
- Fine steel wool (No. 000)
- Heat sink compound, Lincoln Electric #E2529 (Penetrox A-13 or Penetrox A)

SQUARE WAVE TIG 355



TROUBLESHOOTING & REPAIR

SCR REMOVAL AND AND REPLACEMENT *(continued)*

SPECIAL INSTRUCTIONS

Before disassembling the output rectifier, note which heat sink the outer metal ring of the power SCR is mounted toward. Also note the positioning of the gate lead of the SCR. Failure

to reinstall the new SCR in the same orientation as the original may result in subsequent damage to the new SCR and other components of the welder. See Figure F.27.

FIGURE F.27 - SCR DETAILS

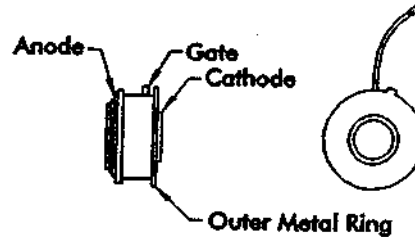

⚠ CAUTION

The unclamping and clamping procedure outlined below is critical for the prevention of internal SCR damage. Failure to follow this procedure may result in subsequent damage of the SCR. Handle all SCRs with care.

PROCEDURE

1. Perform the **Output Rectifier Removal and Replacement** procedure.
2. With the 1/2" wrench, alternately loosen the heat sink nuts 1/2 turn each until the heat sinks are loose. Remove the nuts and leaf spring. **IT IS RECOMMENDED THAT NEW HARDWARE, LEAF SPRING AND HOUSING BE USED FOR REASSEMBLY.**
3. Remove the old SCR.
4. With a puffy knife or similar tool, clean the area on the heat sink around the SCR mounting surface. **DO NOT SCRATCH THE SCR MOUNTING SURFACE.**
5. Polish each heat sink's mounting surface using No. 000 fine steel wool. Wipe the surface clean with a lint-free cloth or paper towel.
6. Inspect the mounting surfaces of each new SCR. Remove all burrs and wipe clean. Do not use steel wool or any abrasive cleanser on the SCR mounting surfaces.
7. Apply a thin (0.001" to 0.003") layer of PENETROX A-13 (Lincoln Electric #E2529) or PENETROX A, heat sink compound, to each heat sink's SCR mounting surface. Use care to prevent foreign material contamination of the SCR-to-heat sink junction.

SQUARE WAVE TIG 355



TROUBLESHOOTING & REPAIR

SCR REMOVAL AND AND REPLACEMENT *(continued)*

8. Place the new SCR between the heat sinks. Be sure that the outer metal ring of the SCR is facing toward the same heat sink as the old SCR's metal ring. Be sure that the roll pin of the heat sink engages the "hole" in the SCR. The SCR contact surfaces must sit flat against both heat sink surfaces.
9. Clamp the SCRs to the output rectifier heat sink assembly.
10. Two different designs of leaf springs and housings have been used to clamp the SCR to the rectifier. The two different designs can be identified by the size of the leaf spring. One design uses a 1/2" wide leaf spring and the other uses a 5/8" wide leaf spring. Follow procedure A below for 1/2" springs. Follow procedure B for 5/8" springs.
11. The different designs require different assembly and clamping procedures, depending upon the thread on the cap screws. A 1/4-28 thread requires a different tightening procedure than a 1/4-20 thread. NOTE WHICH THREAD IS ON YOUR CAP SCREWS BEFORE PERFORMING THE ASSEMBLY PROCEDURE.
 - A. PROCEDURE FOR THE 1/2 INCH WIDE SPRING:
 - 1) Place a piece of sleeving around each cap screw.
 - 2) Insert the cap screws through the leaf spring. Orient the leaf spring so that its ends are curved upward toward the cap screw heads. See Figure F.28. Pressing on the cap screw heads should produce a "rocking" motion of the spring in its housing. If the spring does NOT rock, it is installed upside down. Remove the spring and turn it over. Check for "rocking" motion.
 - 3) Insert the cap screws and leaf spring into the plastic housing.
 - 4) Insert clamp assembly through the heat sinks. Install the nuts. Tighten the clamp nuts equally on the cap screws until finger tight. (See Figure F.29.)

FIGURE F.28 - 1/2" WIDE LEAF SPRING

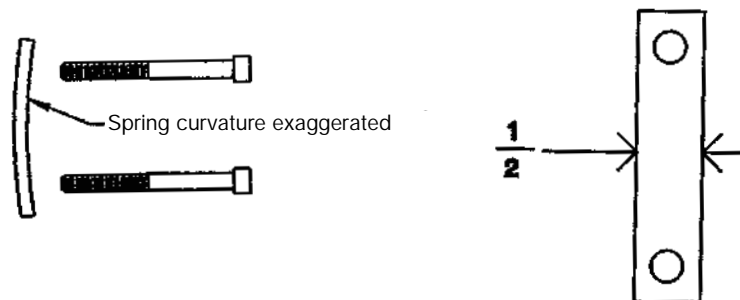

SQUARE WAVE TIG 355



SCR REMOVAL AND AND REPLACEMENT *(continued)*

FIGURE F.29 – SCR CLAMP ASSEMBLY DETAILS – 1/2" WIDE SPRING

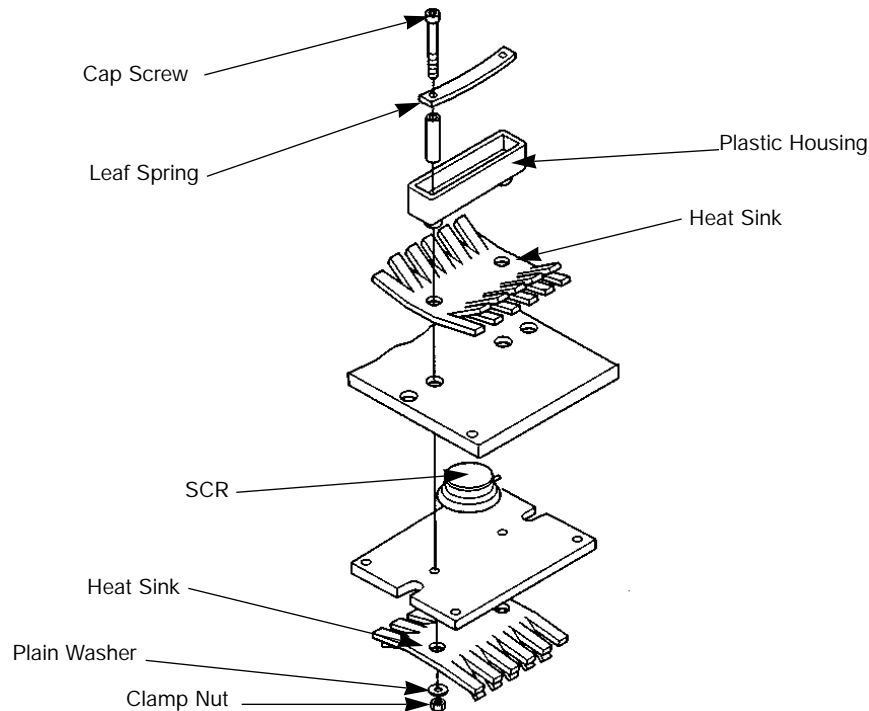

- 5) Re-inspect the SCR for proper seating.
- 6) Clamp the cap screws. Use the procedure for 1/4-28 cap screws or 1/4-20 bolts, depending on which you have.

Clamping procedure for 1/4-28 cap screws.

NOTE: This procedure can only be used with 1/4-28 bolts. Do not use bolts with any other type thread, or the new SCR will be damaged. Do not overtighten the cap screws. The leaf spring will apply the required clamping force to the SCR.

- a. Do not turn the nuts. While holding the nuts stationary, turn the bolts only with the following procedure.
- b. Tighten first cap screw 1/4 turn.
- c. Tighten second cap screw 1/2 turn.
- d. Tighten first cap screw 1/2 turn.
- e. Tighten second cap screw 1/2 turn.

- f. Tighten first cap screw 1/4 turn. Stop. The assembly now has proper clamping force.

Clamping procedure for 1/4-20 cap screws.

NOTE: This procedure can only be used with 1/4-20 cap screws. Do not use cap screws with any other type thread, or the new SCR will be damaged. Do not overtighten the cap screws. The leaf spring will apply the required clamping force to the SCR.

- a. Do not turn the nuts. While holding the nuts stationary, turn the cap screws only with the following procedure.
- b. Tighten first cap screw 1/4 turn.
- c. Tighten second cap screw 1/2 turn.
- d. Tighten first cap screw 1/2 turn.
- e. Tighten second cap screw 1/4 turn. Stop. The assembly now has the proper clamping force.

- 7) Perform the Active SCR Test.

SQUARE WAVE TIG 355



SCR REMOVAL AND AND REPLACEMENT *(continued)*

FIGURE F.30 – HOUSING AND PRESSURE PAD FOR 5/8" WIDE LEAF SPRING

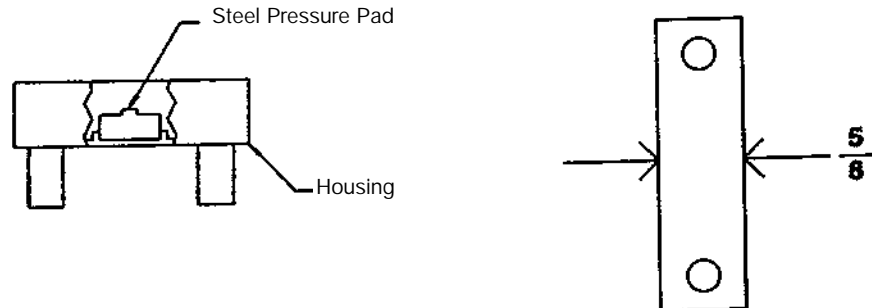

B. PROCEDURE FOR THE 5/8 INCH WIDE SPRING:

- 1) Place a piece of sleeving around each cap screw.
- 2) Insert the cap screws through the leaf spring. The leaf spring is flat so the orientation of the leaf spring does not matter.
- 3) Place the steel pressure pad in the housing with the 1/8" wide standoff facing up. See Figure 30.
- 4) Insert the cap screws and leaf spring into the plastic housing. Be sure that the steel pressure pad remains in position. Pressing on the cap screw heads should produce a rocking action of the spring in its housing.
- 5) Insert the clamp assembly through the heat sinks. Install the nuts. Tighten the clamp nuts equally on the cap screws until finger tight. Be sure that the leaf spring is not cocked in the housing. See Figure 31.
- 6) Re-inspect the SCR for proper seating.
- 7) Clamp the cap screws. Use the procedure for 1/4-28 cap screws or 1/4-20 cap screws, depending on which you have.

Clamping procedure for 1/4-28 cap screws. Note: This procedure can only be used with 1/4-28 cap screws. Do not use cap screws with any other type thread, or the new SCR will be damaged. Do not overtighten the cap screws. The leaf spring will apply the required clamping force to the SCR.

- a. Do not turn the nuts. While holding the nuts stationary, turn the cap screws only with the following procedure.
- b. Tighten first cap screw 1/4 turn.
- c. Tighten second cap screw 1/2 turn.
- d. Tighten first cap screw 1/2 turn.
- e. Tighten second cap screw 1/2 turn.
- f. Tighten first cap screw 1/2 turn.
- g. Tighten second cap screw 1/4 turn. Stop. The assembly now has the proper clamping force.

SCR REMOVAL AND AND REPLACEMENT (continued)

FIGURE F.31 – SCR CLAMP ASSEMBLY DETAILS – 5/8" WIDE SPRING

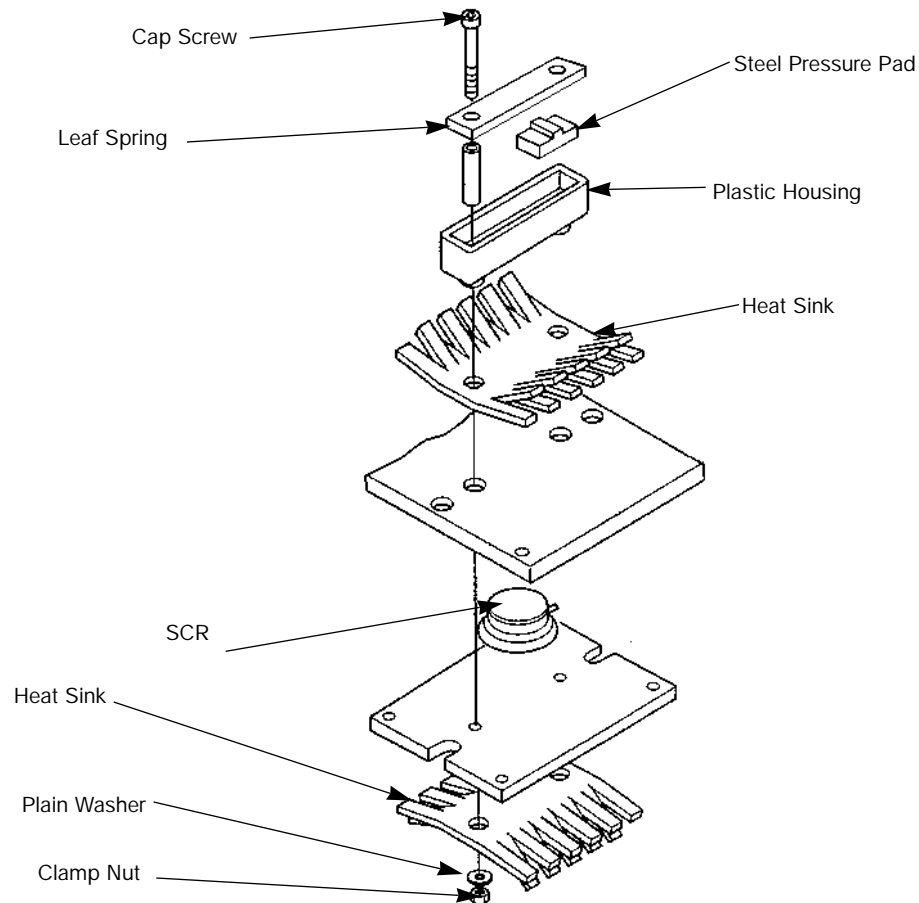

Clamping procedure for 1/4-20 cap screws. Note: This procedure can only be used with 1/4-20 cap screws. Do not use cap screws with any other type thread, or the new SCR will be damaged. Do not overtighten the cap screws. The leaf spring will apply the required clamping force to the SCR.

- a. Do not turn the nuts. While holding the nuts stationary, turn the cap screws only with the following procedure.
- b. Tighten first cap screw 1/4 turn.
- c. Tighten second cap screw 1/2 turn.
- d. Tighten the first cap screw 1/2 turn.

- e. Tighten the second cap screw 1/4 turn.
- f. Tighten the first cap screw 1/8 turn.
- g. Tighten the second cap screw 1/8 turn. Stop. The assembly now has the proper clamping force.

8) Perform the Active SCR Test.

10. Install the output rectifier heat sink assembly back into the machine. See **Output Rectifier Removal and Replacement** in this section of the manual.

SQUARE WAVE TIG 355



TROUBLESHOOTING & REPAIR

RETEST AFTER REPAIR

Retest a machine:

- If it is rejected under test for any reason that requires you to remove any mechanical part which could affect the machine's electrical characteristics.

OR

- If you repair or replace any electrical components.

NOTE: 50 Hz machines may be tested using 60 Hz power.

INPUT AMPS AT RATED MACHINE OUTPUT

Input Volts/Hertz	Load Amps
208/60	110
230/60	100
460/60	50
575/60	40
200/50	115
220/50	104
380/50	61
440/50	52

INPUT IDLE AMPS

Input Volts/Hertz	Maximum Idle Amps
230/60	62
220/50	50

NOTE: Power factor correction capacitors are standard on all models. The capacitors cause high idle currents, but idle power is low.

OPEN CIRCUIT VOLTAGES

Stick Mode OCV	AC 60-70 DC 60-70
TIG Mode OCV	AC 60-70 DC 60-70

SQUARE WAVE TIG 355



TROUBLESHOOTING & REPAIR

RETEST AFTER REPAIR *(continued)*

OUTPUT CURRENT RANGE

2 - 400 Amps AC and DC

RECOMMENDED METERS FOR MACHINE OUTPUT TESTS

- VOLTMETER: AC and DC True RMS Meter – Fluke 8922A or equivalent
 AMMETER: Columbia Type AX AC or DC Tong Ammeter

IMPORTANT: IF OTHER TYPE METERS ARE USED RESULTS MAY NOT BE ACCURATE

FIGURE F32. – TRANSFORMER LEAD TEST POINTS

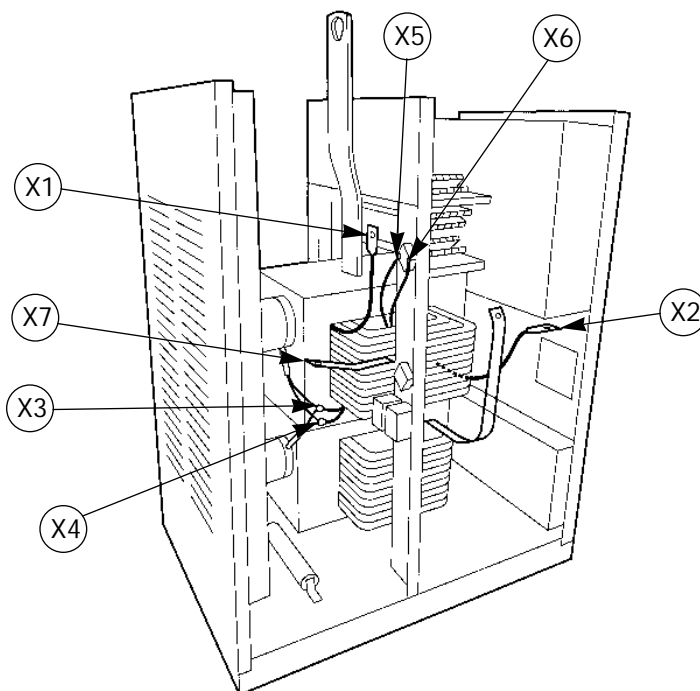

MAIN TRANSFORMER SECONDARY VOLTAGES (SEE FIGURE F32)

Test Points	Voltages
X1 to X2	84 to 89VAC
X3 to X4	117 to 125VAC
X5 to X6	22 to 24VAC
X2 to X7	77 to 81VAC

SQUARE WAVE TIG 355



Return to Section TOC
Return to Master TOC
Return to Section TOC
Return to Master TOC
Return to Section TOC
Return to Master TOC
Return to Section TOC
Return to Master TOC

TABLE OF CONTENTS - ELECTRICAL DIAGRAMS SECTION -

Electrical Diagram Section Section G

Wiring Diagram G-2

Machine Schematic G-3

Meter PC Board (M15893) Schematic G-4

Feed Through PC Board (L8096) Schematic G-5

Protection PC Board (M16062) Schematic G-6

Power PC Board (G2081) Schematic G-7

Control PC Board (G2512) Schematic G-8

Protection PC Board (M16062) Layout G-9

Power PC Board (G2081) Layout G-10

Bypass PC Board (M15299) Layout G-11

Feed Through PC Board (L8096) Layout G-12

Control PC Board (G2512) Layout G-13

Meter PC Board (M15893) Layout G-14

Return to Master TOC

Return to Master TOC

Return to Master TOC

Return to Master TOC

SQUARE WAVE TIG 355



NOTES

Return to Section TOC

Return to Section TOC

Return to Section TOC

Return to Section TOC

Return to Master TOC

Return to Master TOC

Return to Master TOC

Return to Master TOC

SQUARE WAVE TIG 355



Wiring Diagram

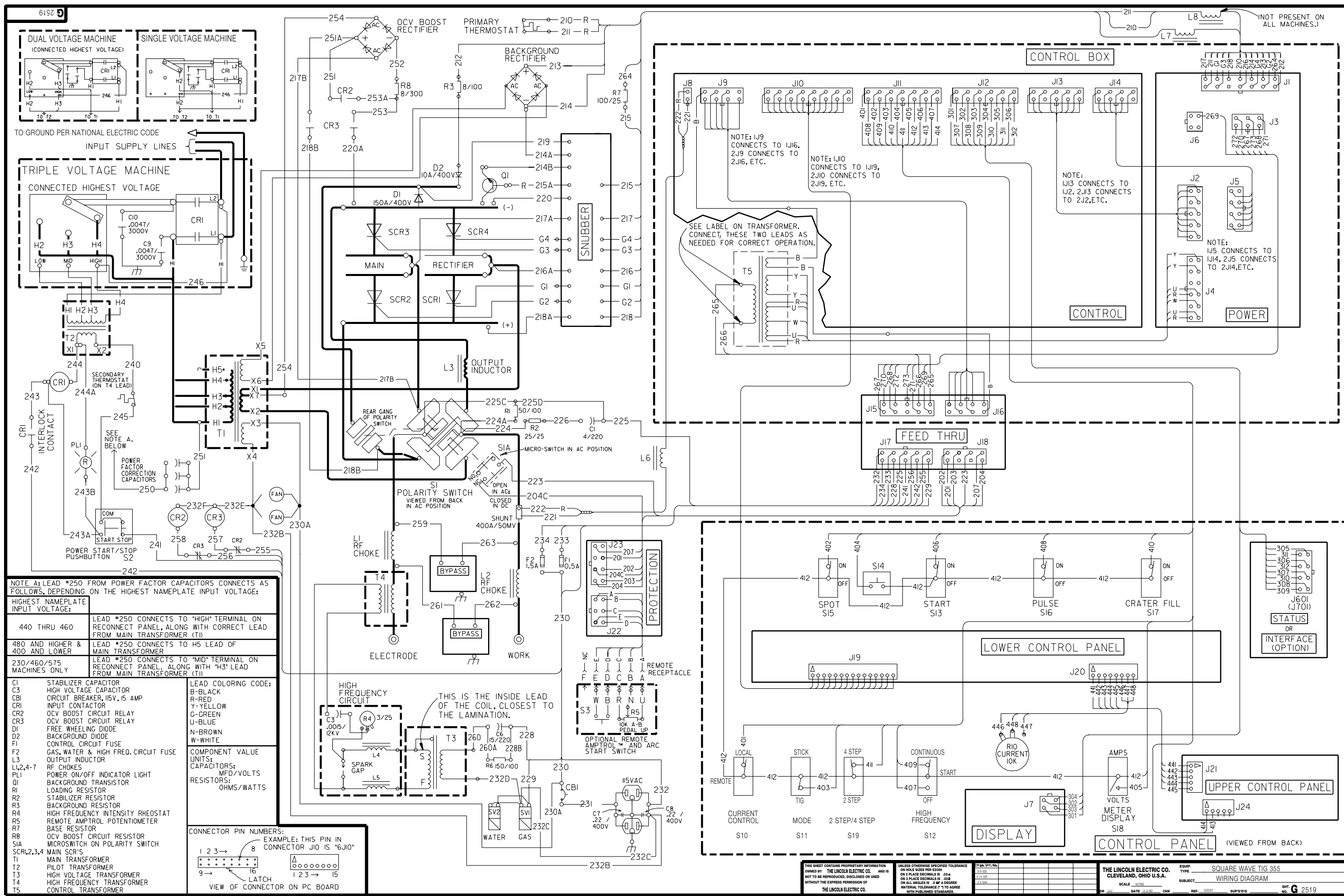

NOTE: This diagram is for reference only. It may not be accurate for all machines covered by this manual. The specific diagram for a particular code is pasted inside the machine on one of the enclosure panels.



Return to Section TOC
Return to Master TOC
Return to Section TOC
Return to Master TOC
Return to Section TOC
Return to Master TOC
Return to Section TOC
Return to Master TOC

Machine Schematic

Return to Section TOC

Return to Section TOC

Return to Section TOC

Return to Section TOC

Return to Master TOC

Return to Master TOC

Return to Master TOC

Return to Master TOC

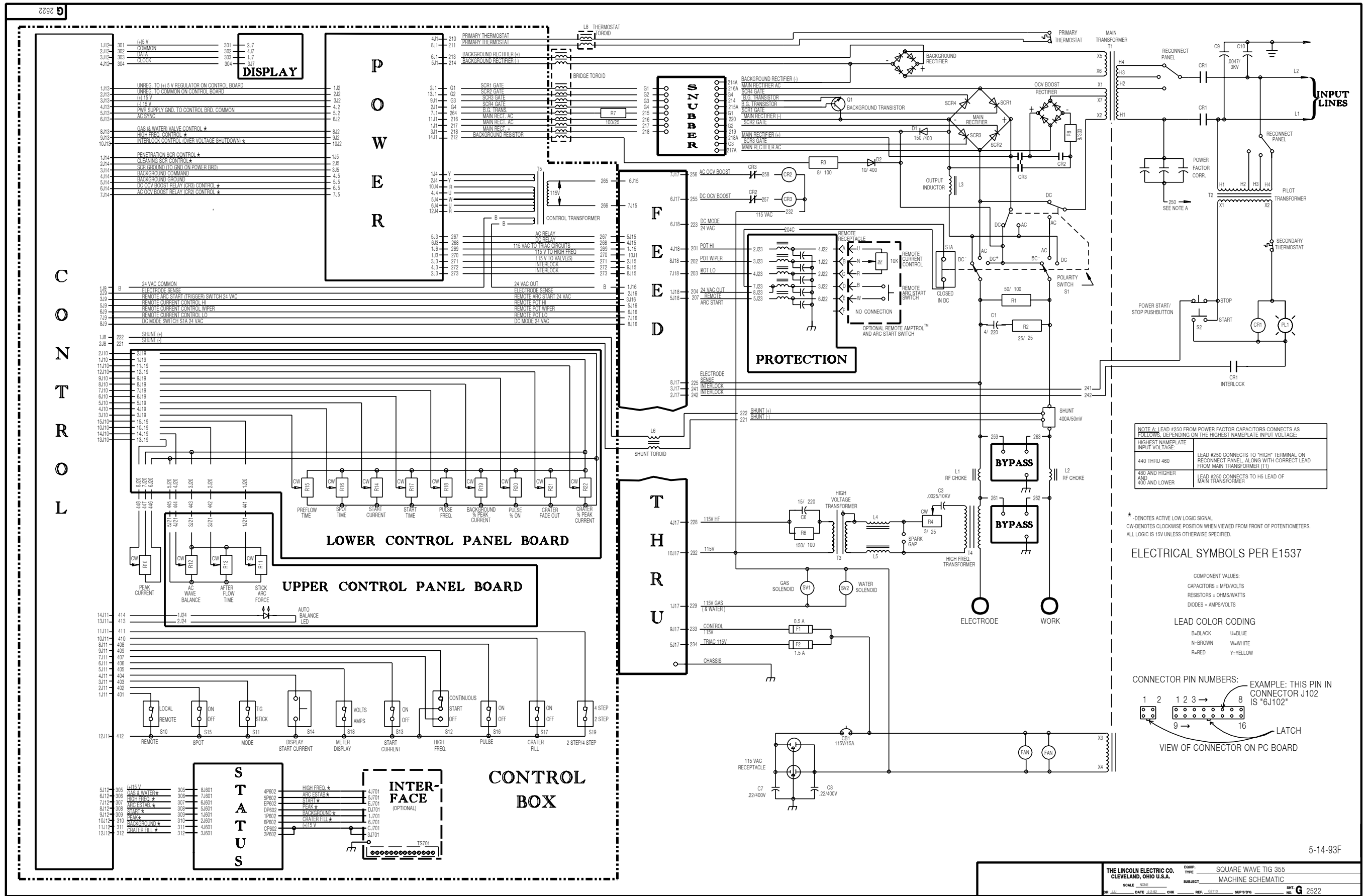

NOTE A: LEAD #250 FROM POWER FACTOR CAPACITORS CONNECTS AS FOLLOWS, DEPENDING ON THE HIGHEST NAMEPLATE INPUT VOLTAGE:

HIGHEST NAMEPLATE INPUT VOLTAGE:	LEAD #250 CONNECTS TO "HIGH" TERMINAL ON RECONNECT PANEL, ALONG WITH CORRECT LEAD FROM MAIN TRANSFORMER (T1)
440 THRU 460	
480 AND HIGHER AND 400 AND LOWER	LEAD #250 CONNECTS TO H5 LEAD OF MAIN TRANSFORMER

* - DENOTES ACTIVE LOW LOGIC SIGNAL
 CW - DENOTES CLOCKWISE POSITION WHEN VIEWED FROM FRONT OF POTENTIOMETERS.
 ALL LOGIC IS 15V UNLESS OTHERWISE SPECIFIED.

ELECTRICAL SYMBOLS PER E1537

- COMPONENT VALUES:
 CAPACITORS = MFD/VOLTS
 RESISTORS = OHMS/WATTS
 DIODES = AMPS/VOLTS
- LEAD COLOR CODING
 B-BLACK U-BLUE
 N-BROWN W-WHITE
 R-RED Y-YELLOW

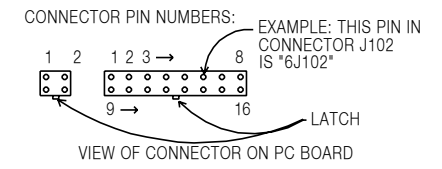

NOTE: This diagram is for reference only. It may not be totally applicable to every code covered by this manual.



THE LINCOLN ELECTRIC CO. CLEVELAND, OHIO U.S.A.
 EQUIP. TYPE: SQUARE WAVE TIG 355
 SUBJECT: MACHINE SCHEMATIC
 SCALE: NONE
 DATE: 4-2-93
 CHK: REF: 50113
 SUPP'D TO: SHIP. NO. G 2522

Meter PC Board (M15893) Schematic

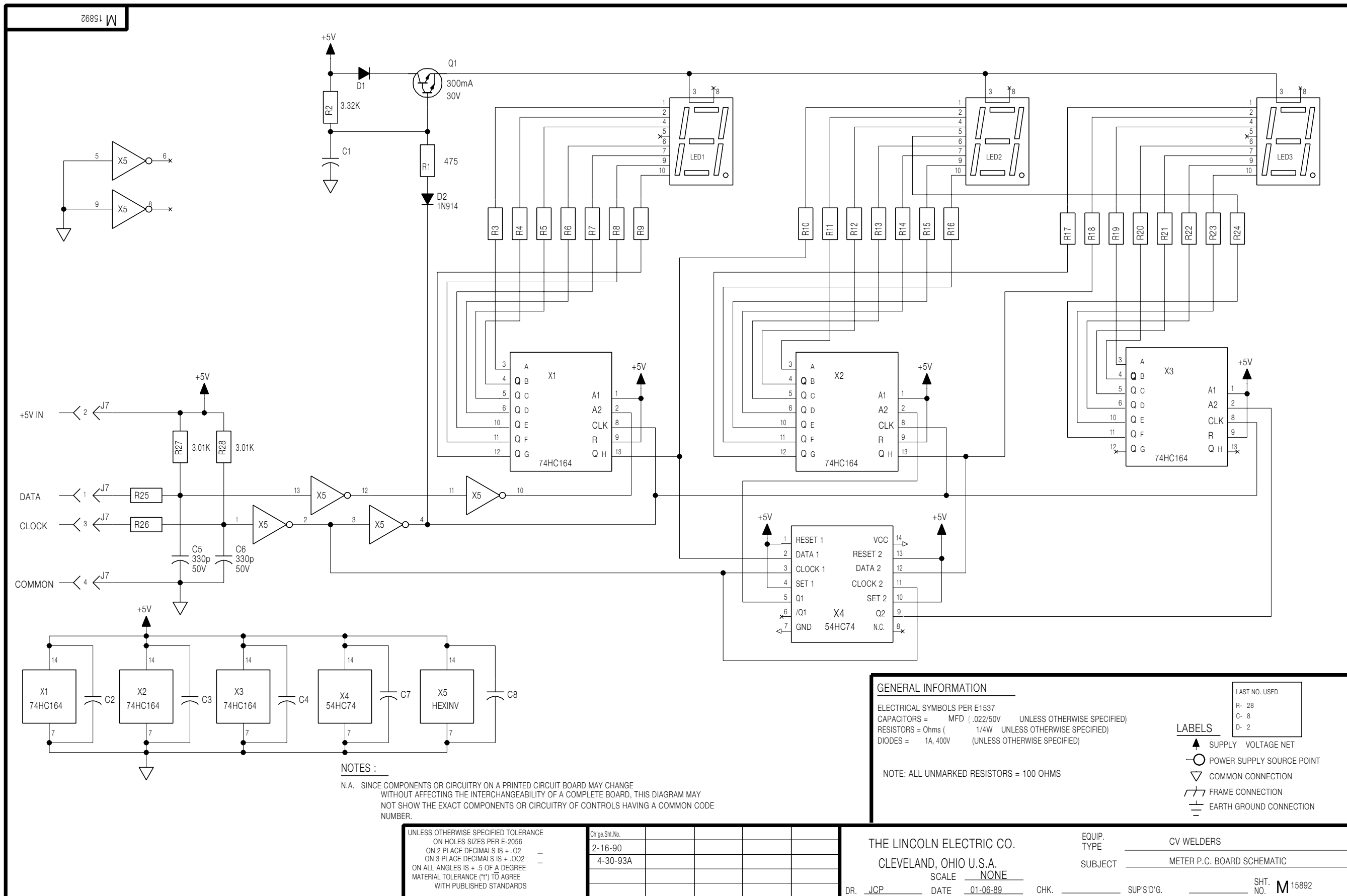

GENERAL INFORMATION

ELECTRICAL SYMBOLS PER E1537
 CAPACITORS = MFD | .022/50V UNLESS OTHERWISE SPECIFIED)
 RESISTORS = Ohms (1/4W UNLESS OTHERWISE SPECIFIED)
 DIODES = 1A, 400V (UNLESS OTHERWISE SPECIFIED)

NOTE: ALL UNMARKED RESISTORS = 100 OHMS

LABELS

▲ SUPPLY VOLTAGE NET
 ○ POWER SUPPLY SOURCE POINT
 ▽ COMMON CONNECTION
 □ FRAME CONNECTION
 ⊥ EARTH GROUND CONNECTION

LAST NO. USED
 R- 28
 C- 8
 D- 2

NOTES :
 N.A. SINCE COMPONENTS OR CIRCUITRY ON A PRINTED CIRCUIT BOARD MAY CHANGE WITHOUT AFFECTING THE INTERCHANGEABILITY OF A COMPLETE BOARD, THIS DIAGRAM MAY NOT SHOW THE EXACT COMPONENTS OR CIRCUITRY OF CONTROLS HAVING A COMMON CODE NUMBER.

UNLESS OTHERWISE SPECIFIED TOLERANCE ON HOLES SIZES PER E-2056 ON 2 PLACE DECIMALS IS + .02 ON 3 PLACE DECIMALS IS + .002 ON ALL ANGLES IS + .5 OF A DEGREE MATERIAL TOLERANCE ("I") TO AGREE WITH PUBLISHED STANDARDS	Ch'ge. Sht. No. 2-16-90 4-30-93A			
--	--	--	--	--

THE LINCOLN ELECTRIC CO. CLEVELAND, OHIO U.S.A. SCALE NONE	EQUIP. TYPE CV WELDERS SUBJECT METER P.C. BOARD SCHEMATIC
DR. JCP DATE 01-06-89 CHK. SUP'S'D'G. SHT. NO. M15892	

NOTE: Lincoln Electric assumes no responsibility for liabilities resulting from board level troubleshooting. PC Board repairs will invalidate your factory warranty. **Individual Printed Circuit Board Components are not available from Lincoln Electric.** This information is provided for reference only. Lincoln Electric discourages board level troubleshooting and repair since it may compromise the quality of the design and may result in danger to the Machine Operator or Technician. Improper PC board repairs could result in damage to the machine.



Return to Section TOC

Feed Through PC Board (L8096) Schematic

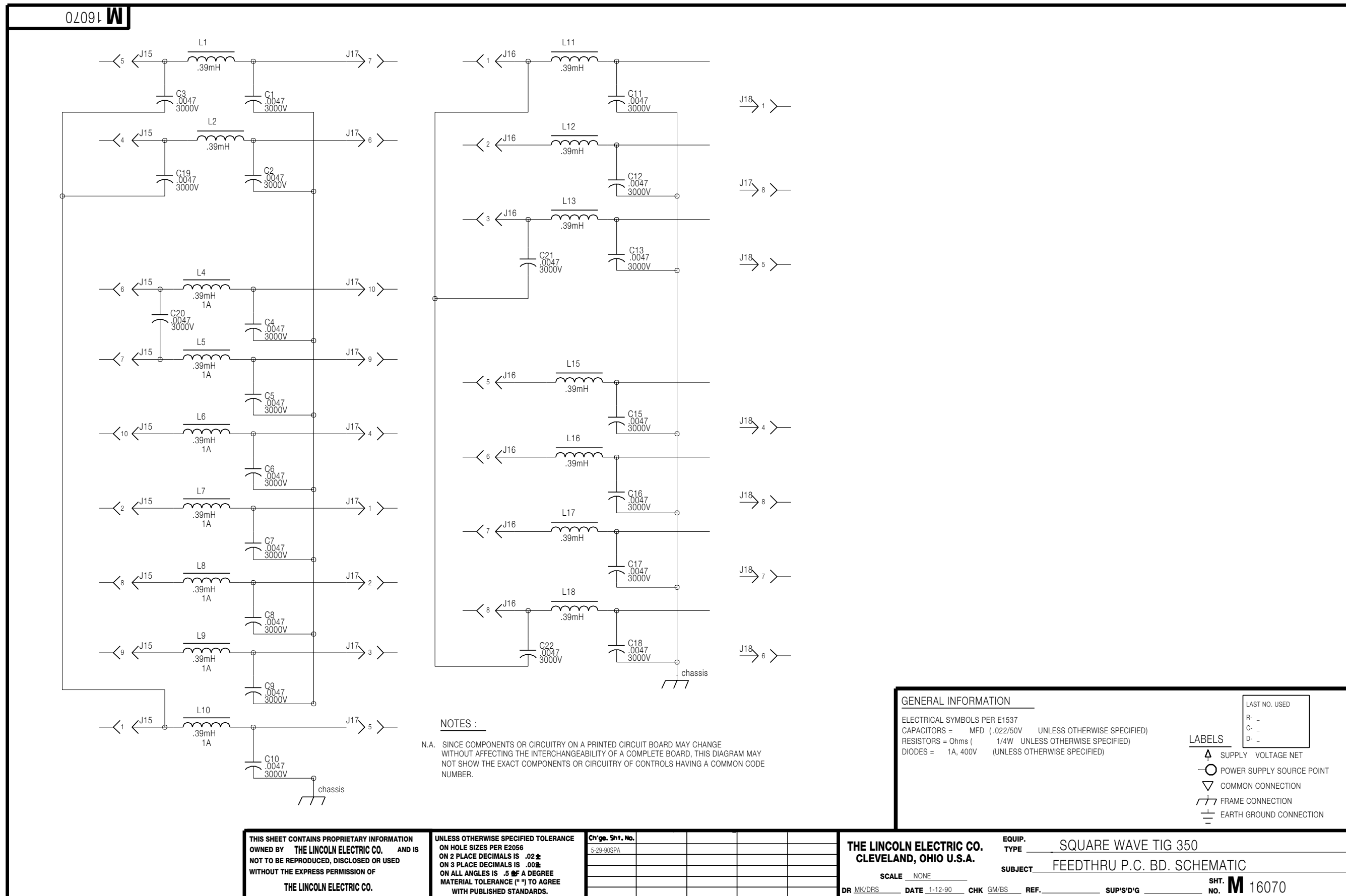

NOTE: Lincoln Electric assumes no responsibility for liabilities resulting from board level troubleshooting. PC Board repairs will invalidate your factory warranty. **Individual Printed Circuit Board Components are not available from Lincoln Electric.** This information is provided for reference only. Lincoln Electric discourages board level troubleshooting and repair since it may compromise the quality of the design and may result in danger to the Machine Operator or Technician. Improper PC board repairs could result in damage to the machine.



Return to Section TOC

Return to Master TOC

Return to Section TOC

Return to Master TOC

Return to Section TOC

Return to Master TOC

Return to Section TOC

Return to Master TOC

Protection PC Board (M16062) Schematic

M 16115

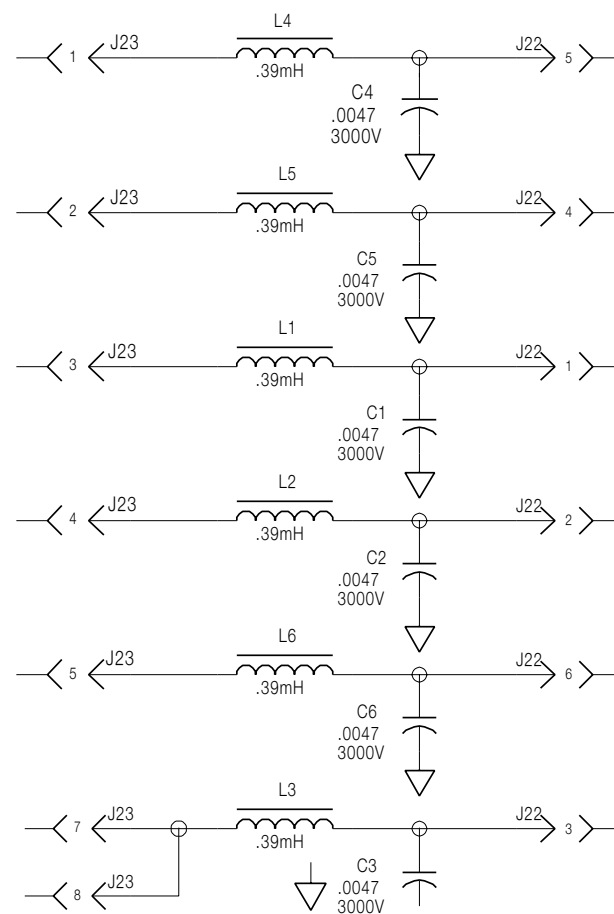

NOTES :

N.A. SINCE COMPONENTS OR CIRCUITRY ON A PRINTED CIRCUIT BOARD MAY CHANGE WITHOUT AFFECTING THE INTERCHANGEABILITY OF A COMPLETE BOARD, THIS DIAGRAM MAY NOT SHOW THE EXACT COMPONENTS OR CIRCUITRY OF CONTROLS HAVING A COMMON CODE NUMBER.

THIS SHEET CONTAINS PROPRIETARY INFORMATION OWNED BY THE LINCOLN ELECTRIC CO. AND IS NOT TO BE REPRODUCED, DISCLOSED OR USED WITHOUT THE EXPRESS PERMISSION OF THE LINCOLN ELECTRIC CO.

UNLESS OTHERWISE SPECIFIED TOLERANCE ON HOLE SIZES PER E2056 ON 2 PLACE DECIMALS IS .02 ON 3 PLACE DECIMALS IS .005 ON ALL ANGLES IS .5 OF A DEGREE MATERIAL TOLERANCE (" ") TO AGREE WITH PUBLISHED STANDARDS.

Chg. Sht. No.					
5-29-90SPA					

GENERAL INFORMATION

ELECTRICAL SYMBOLS PER E1537
 CAPACITORS = MFD (.022/50V UNLESS OTHERWISE SPECIFIED)
 RESISTORS = Ohms (1/4W UNLESS OTHERWISE SPECIFIED)
 DIODES = 1A, 400V (UNLESS OTHERWISE SPECIFIED)

LAST NO. USED	
R-	-
C-	-
D-	-

LABELS

- ▲ SUPPLY VOLTAGE NET
- POWER SUPPLY SOURCE POINT
- ▽ COMMON CONNECTION
- ⚡ FRAME CONNECTION
- ⊥ EARTH GROUND CONNECTION

THE LINCOLN ELECTRIC CO.
 CLEVELAND, OHIO U.S.A.

EQUIP. TYPE SQUARE WAVE TIG 350
 SUBJECT PROTECTION P.C. BOARD SCHEMATIC

SCALE NONE
 DR MK/DRS DATE 1-12-90 CHK GM/BS REF. SUP'S'D'G SHT. NO. M 16115

NOTE: Lincoln Electric assumes no responsibility for liabilities resulting from board level troubleshooting. PC Board repairs will invalidate your factory warranty. **Individual Printed Circuit Board Components are not available from Lincoln Electric.** This information is provided for reference only. Lincoln Electric discourages board level troubleshooting and repair since it may compromise the quality of the design and may result in danger to the Machine Operator or Technician. Improper PC board repairs could result in damage to the machine.



Return to Section TOC

Return to Section TOC

Return to Section TOC

Return to Section TOC

Return to Master TOC

Return to Master TOC

Return to Master TOC

Return to Master TOC

Control PC Board (G2512) Schematic

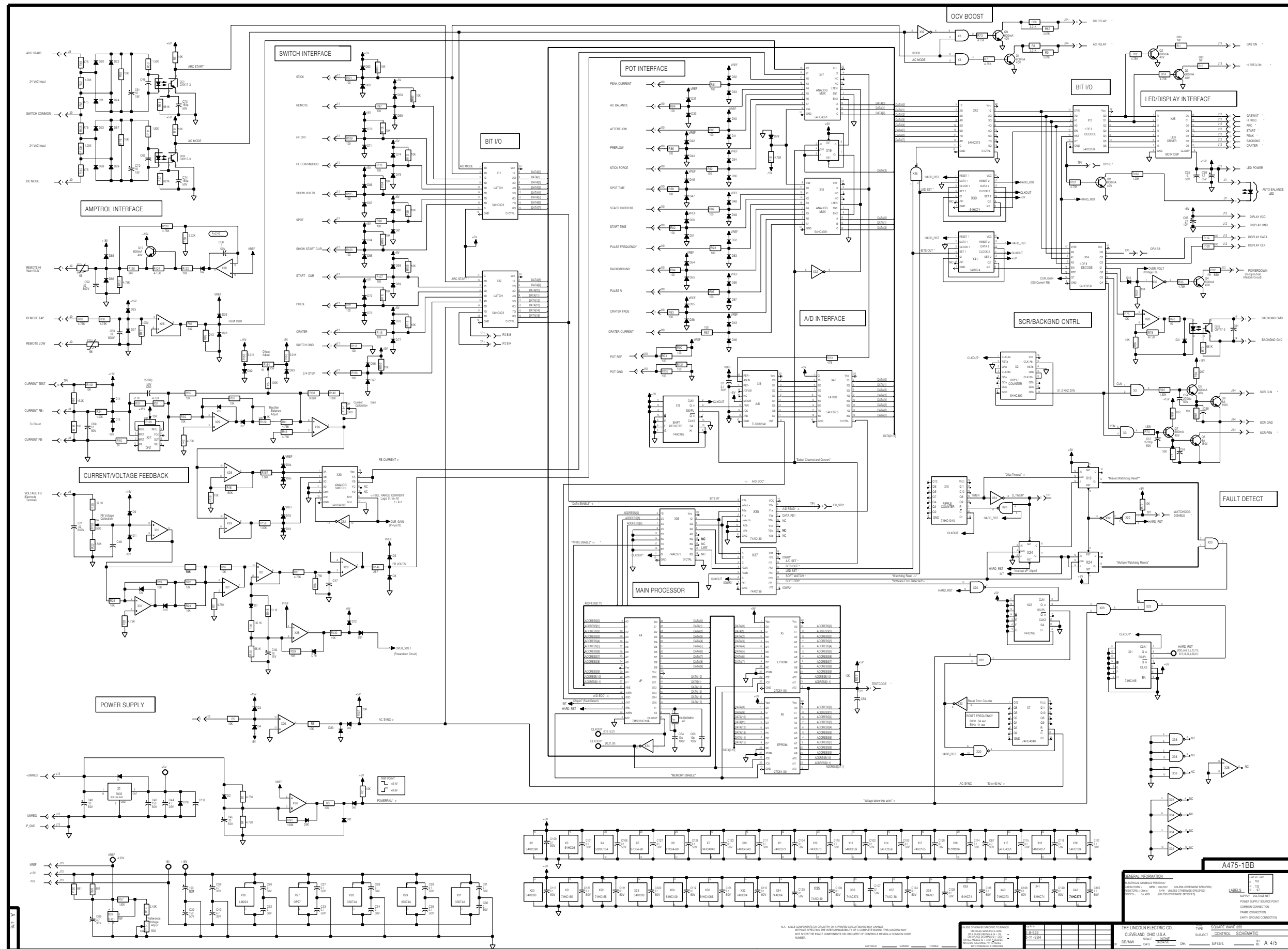

NOTE: Lincoln Electric assumes no responsibility for liabilities resulting from board level troubleshooting. PC Board repairs will invalidate your factory warranty. **Individual Printed Circuit Board Components are not available from Lincoln Electric.** This information is provided for reference only. Lincoln Electric discourages board level troubleshooting and repair since it may compromise the quality of the design and may result in danger to the Machine Operator or Technician. Improper PC board repairs could result in damage to the machine.



Return to Section TOC

Return to Master TOC

Return to Section TOC

Return to Master TOC

Return to Section TOC

Return to Master TOC

Return to Section TOC

Return to Master TOC

GENERAL INFORMATION

ELECTRICAL SYMBOLS FOR THIS BOARD ARE SUBJECT TO CHANGE WITHOUT NOTICE UNLESS OTHERWISE SPECIFIED.

REVISIONS: 1 - REV. 02/05 (UNLESS OTHERWISE SPECIFIED)

DESIGNED BY: J. W. BROWN

DRAWN BY: J. W. BROWN

DATE: 02/05

SCALE: AS SHOWN

PROJECT: CONTROL SCHEMATIC

WORK CENTER: 4475

APP'D: [Signature]

CHK: [Signature]

REV: A 475

Protection PC Board (M16062) Layout

M16062

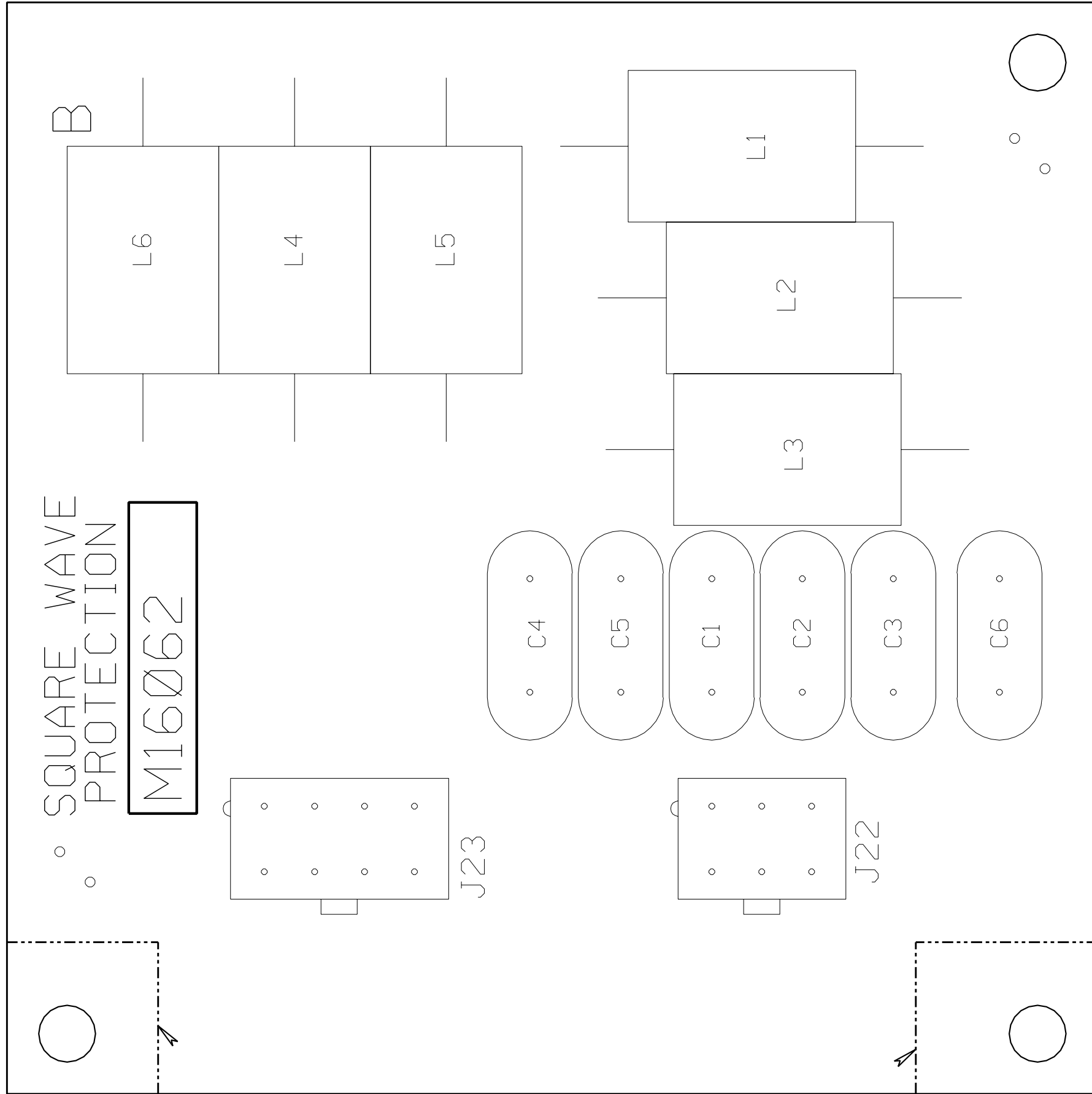

ITEM	REQ'D	PART NO.	IDENTIFICATION
C1, C2, C3, C4, C5, C6	6	T11577-58	.0047/3000 V
L1, L2, L3, L4, L5, L6	6	T12218-9F	.39 mH
J22	1	S18248-6	HEADER
J23	1	S18248-8	HEADER
1	1	L8081-B	P.C. BD BLANK

CAPACITORS = MFD/VOLTS

NOTE: Lincoln Electric assumes no responsibility for liabilities resulting from board level troubleshooting. PC Board repairs will invalidate your factory warranty. **Individual Printed Circuit Board Components are not available from Lincoln Electric.** This information is provided for reference only. Lincoln Electric discourages board level troubleshooting and repair since it may compromise the quality of the design and may result in danger to the Machine Operator or Technician. Improper PC board repairs could result in damage to the machine.



Return to Section TOC

Return to Section TOC

Return to Section TOC

Return to Section TOC

Return to Master TOC

Return to Master TOC

Return to Master TOC

Return to Master TOC

Power PC Board (G2081) Layout

G2081

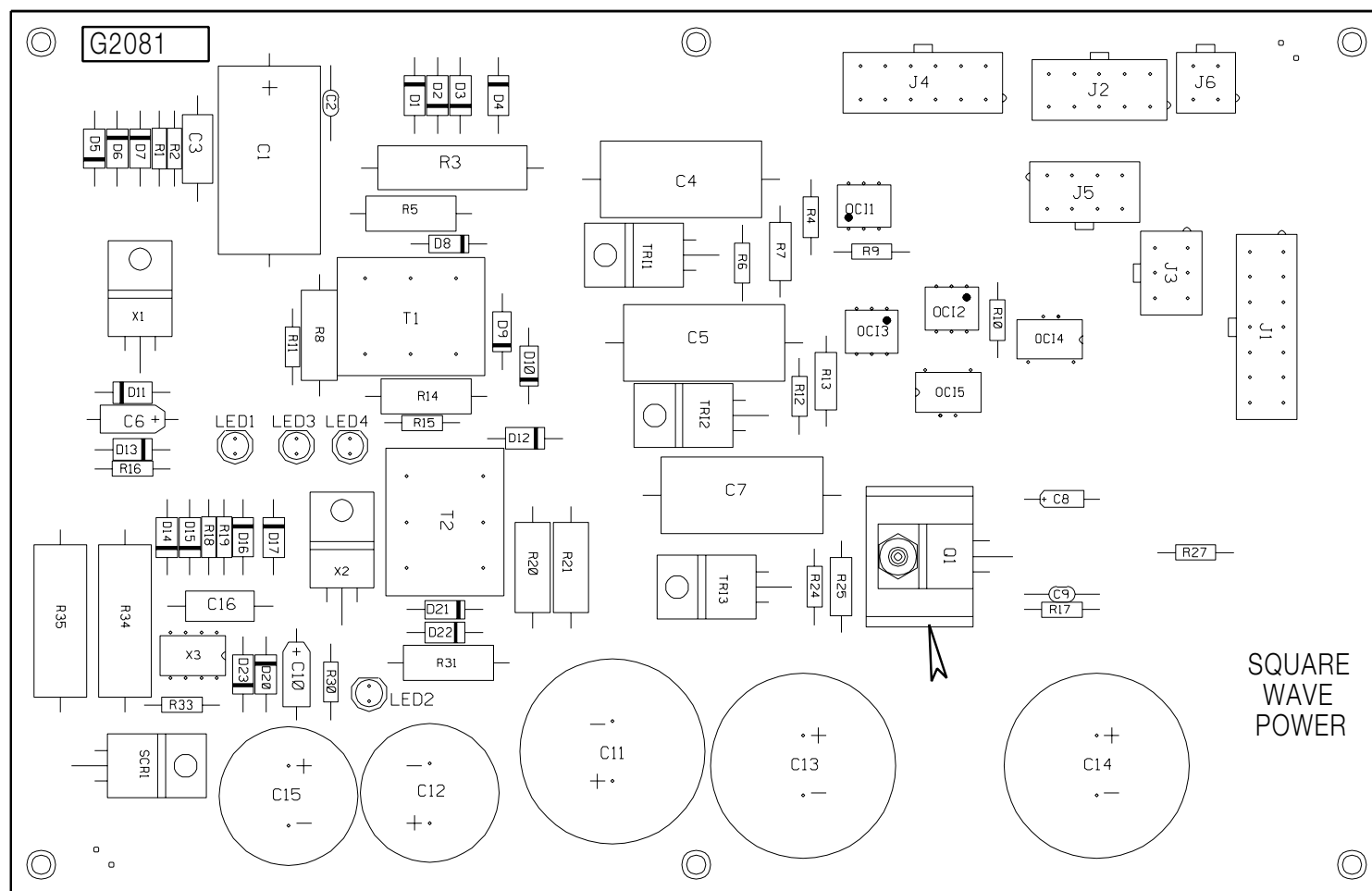

CAPACITORS = MFD/VOLTS
 RESISTORS = OHMS/ 1/4 WATT UNLESS OTHERWISE SPECIFIED.
 INDUCTANCE = HENRY'S

ITEM	REQ'D.	IDENTIFICATION
C1	1	150/50
C2,C9	2	.022/50
C3,C16	2	.047/100
C4, C5, C7	3	.1/400
C6, C10	2	2.7/50
C8	1	.47/50
C11, C13, C14	3	3300/50
C12, C15	2	1000/35
D1 thru D7, D11 thru D17, D20,D22,D23	17	1N4004
D8,D9,D10,D21	4	1N4936
J1	1	HEADER
J2	1	HEADER
J3	1	HEADER
J4	1	HEADER
J5	1	HEADER
J6	1	HEADER
LED1, LED2, LED3, LED4	4	RED LED
OCI1, OCI2, OCI3	3	3043
OCI4, OCI5	2	CS5010
Q1	1	TRANS-P T220 3 A, 100V, TIP32C
R1, R2, R6, R12, R24	5	15K 1/4W
R3	1	1.0 5W
R4, R9, R10	3	200 1/4W
R5, R8, R14, R20	4	15 1W
R7, R13, R25	3	27 1/2W
R11, R15	2	10 1/4W
R16, R30	2	2.21K 1/4W
R17	1	47.5K
R18	1	3.01K 1/4W
R19	1	68.1K 1/4W
R21, R31	2	2.7 1W
R27	1	4.75K 1/4W
R33	1	150 1/4W
R34,R35	2	1/ 2 5W
SCR1	1	2N6508
T1, T2	2	1:1:1
TRI1, TRI2, TRI3	3	T2500D
X1	1	VOLT-REG, FIXED 3-ft (+), 1A,15V
X2	1	VOLT-REG, FIXED 3-T (-), 1A,15V
X3	1	OVER VOLTAGE SENSING 3523

NOTE: Lincoln Electric assumes no responsibility for liabilities resulting from board level troubleshooting. PC Board repairs will invalidate your factory warranty. **Individual Printed Circuit Board Components are not available from Lincoln Electric.** This information is provided for reference only. Lincoln Electric discourages board level troubleshooting and repair since it may compromise the quality of the design and may result in danger to the Machine Operator or Technician. Improper PC board repairs could result in damage to the machine.



Return to Section TOC

Return to Master TOC

Return to Section TOC

Return to Master TOC

Return to Section TOC

Return to Master TOC

Return to Section TOC

Return to Master TOC

Bypass PC Board (M15299) Layout

Return to Section TOC
Return to Master TOC
Return to Section TOC
Return to Master TOC
Return to Section TOC
Return to Master TOC
Return to Section TOC
Return to Master TOC

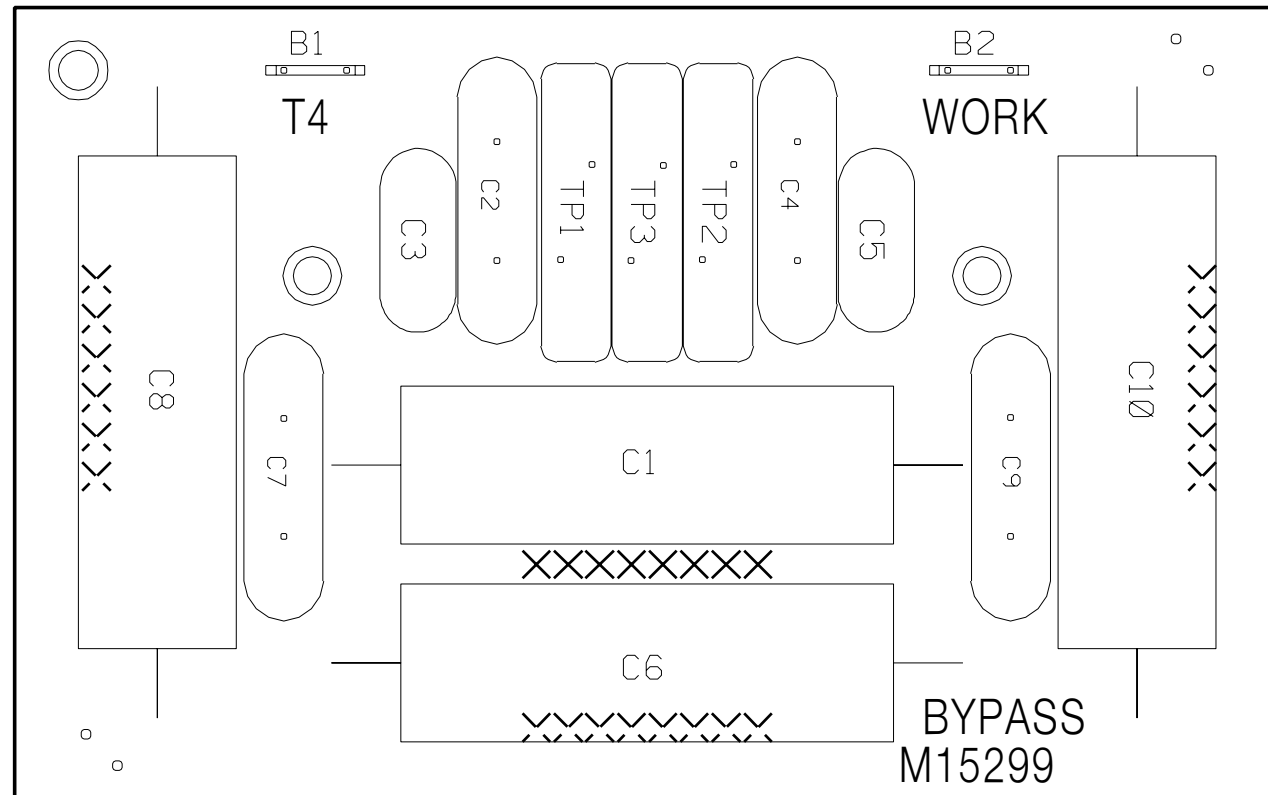

M15299

ITEM	REQD	IDENTIFICATION
B 1, B2	2	TAB TERMINAL
C 1, C 6, C 8, C 10	4	. 047/ 1000
C 2, C 4, C 7, C 9	4	. 05/600V
C 3, C 5	2	. 0047 or . 005/ 1400
TP 1, TP 2, TP 3	3	80J

CAPACITORS = MFD/VOLTS

NOTE: Lincoln Electric assumes no responsibility for liabilities resulting from board level troubleshooting. PC Board repairs will invalidate your factory warranty. **Individual Printed Circuit Board Components are not available from Lincoln Electric.** This information is provided for reference only. Lincoln Electric discourages board level troubleshooting and repair since it may compromise the quality of the design and may result in danger to the Machine Operator or Technician. Improper PC board repairs could result in damage to the machine.



Feed Through PC Board (L9096) Layout

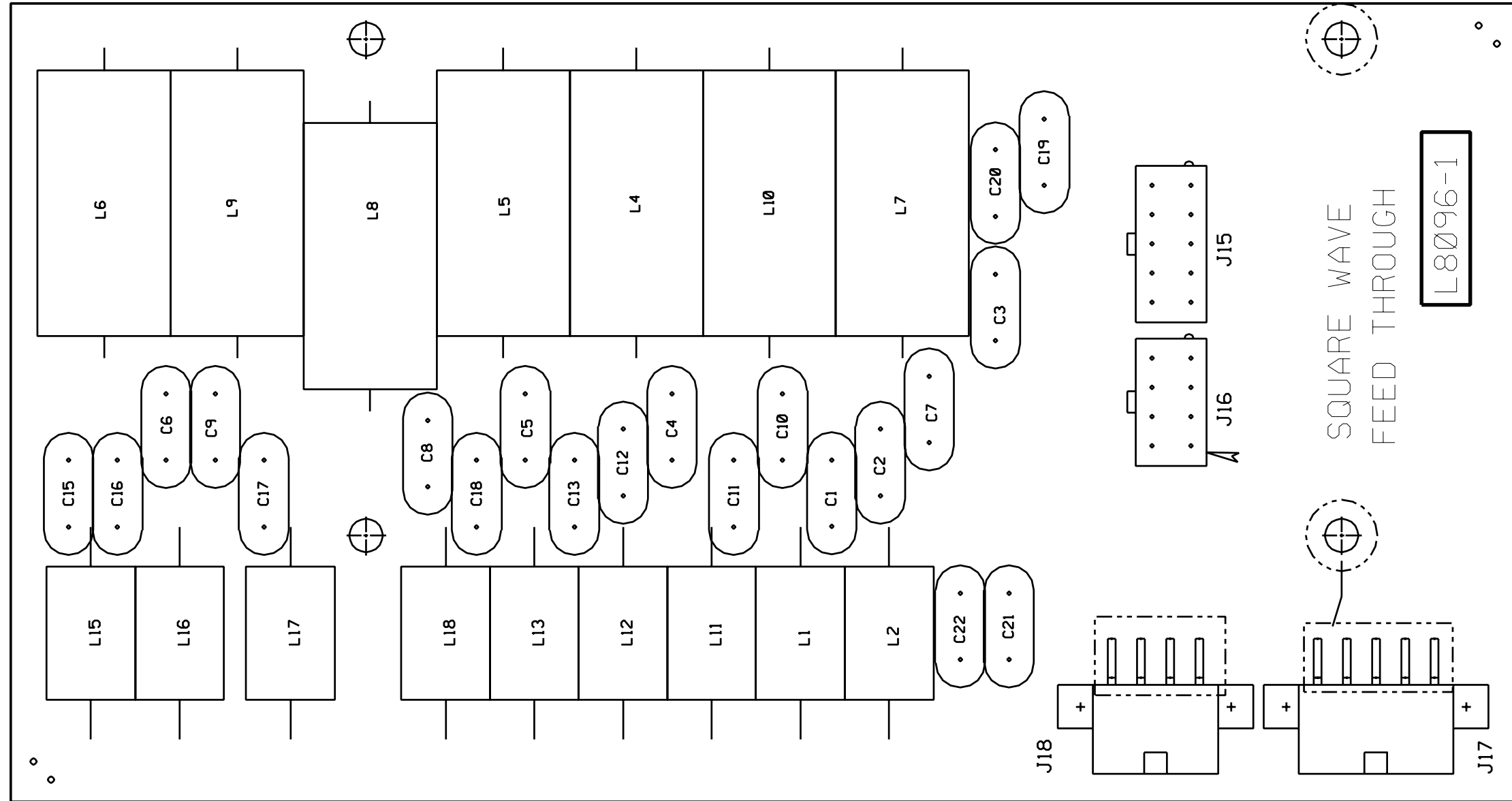

ITEM	REQ'D	IDENTIFICATION
C1,C2,C3,C4,C5,C6,C7,C8,C9,C10,C11,C12,C13,C15,C16,C17,C18,C19,C20,C21,C22	21	.0047/3000 V
L1,L2,L11,L12,L13,L15,L16,L17,L18	9	0.39mH, 225mA
L4,L5,L6,L7,L8,L9,L10	7	0.39mH, 1A

CAPACITORS = MFD/VOLTS
INDUCTANCE = HENRYS

L8096

NOTE: Lincoln Electric assumes no responsibility for liabilities resulting from board level troubleshooting. PC Board repairs will invalidate your factory warranty. **Individual Printed Circuit Board Components are not available from Lincoln Electric.** This information is provided for reference only. Lincoln Electric discourages board level troubleshooting and repair since it may compromise the quality of the design and may result in danger to the Machine Operator or Technician. Improper PC board repairs could result in damage to the machine.



Return to Section TOC

Return to Section TOC

Return to Section TOC

Return to Section TOC

Return to Master TOC

Return to Master TOC

Return to Master TOC

Return to Master TOC

Control PC Board (G2512) Layout

G2512

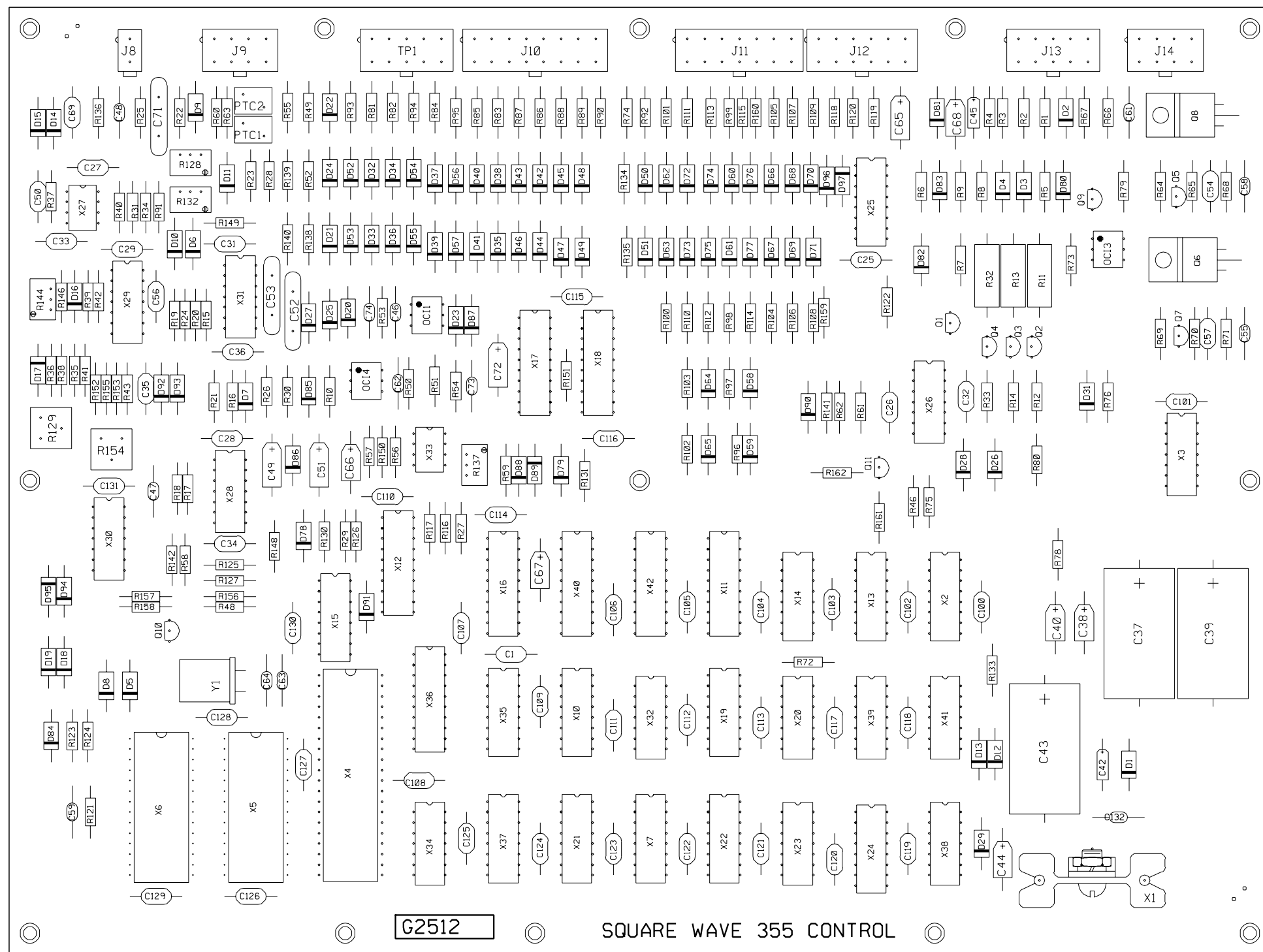

ITEM	REQ'D.	IDENTIFICATION
C1,C25-C29,C31-C36,C56,C69,C100-C131	46	0.1 / 50
C37,C39,C43	3	150 / 50
C38,C40,C44,C66,C67,C68	6	4.7 / 35
C42,C45	2	.33 / 50
C46,C47,C48,C55,C58,C59,C61,C62,C132	9	.022 / 50
C49,C51,C72	3	18 / 15
C50,C54,C57	3	2700pf / 50
C52,C53,C71	3	.02 / 600
C63,C64	2	10pf / 100
C65	1	27 / 10
C73,C74	2	150pf / 100
D1 thru D29, D31 thru D37	96	1N4004
OC11,OC13,OC14	3	
Q1 thru Q5,Q7,Q9,Q10,Q11	9	
Q6,Q8	2	
PTC1,PTC2	2	56, 20%
R1,R4,R7,R12,R14,R17,R18,R21, R28,R31,R33,R41,R42,R43,R60, R63,R73,R126,R127,R131,R161	21	4.75 K 1/4W
R2,R3,R5,R6,R10,R15,R16,R19, R20,R23,R24,R29,R35,R36,R39, R51,R53,R68,R71,R72,R75,R80, R96,R98,R100,R102,R104,R106,R108, R110,R112,R114,R116,R121,R122,R123, R130,R133,R149,R156,R159	41	10K 1/4 W
R8,R9,R66,R67,R152,R153	6	3.01 K 1/4W
R11,R13,R32	3	680 1W
R22,R50,R65,R70,R117	5	1.5 K 1/4W
R25	1	22.1 K 1/4W
R26	1	30.1 K 1/4W
R27,R54,R79	3	681 K 1/4W
R30	1	68.1 K 1/4W
R34,R40,R52,R76,R139,R146,R157,R158,R162	9	1 K 1/4W
R37,R148	2	51.1 K 1/4W
R38	1	9.09 K 1/4W
R46	1	1 M 1/4W
R48	1	150 K 1/4W
R49,R55,R138,R140,R151	5	475 1/4W
R56,R150	2	681 1/4W
R57	1	1.82 K 1/4W
R58	1	3.32 K 1/4W
R59	1	2.43 K 1/4W
R61	1	332 1/4W
R62	1	243 1/4W
R64,R69,R125,R142	4	267 1/4W
R74,R81,R82,R83,R84,R85,R86, R87,R88,R89,R90,R92,R93,R94, R95,R97,R99,R101,R103,R105, R107,R109,R111,R113,R115,R118, R119,R120,R134,R135,R136,R160	32	100 1/4W
R78,R124	2	47.5 K 1/4W
R91	1	16.2 K 1/4W
R128	1	10K 10T
R129,R154	2	1K 1T
R132,R137,R144	3	500 10T
R141,R155	2	100 K 1/4W
X1	1	VOLTAGE REG
X2	1	BINARY COUNTER, 4 STAGE
X3,X23	2	HC08A AND GATE
X4	1	IC-CMOS,MCU,DSP,320
X5	1	ROM ASBLY
X6	1	ROM ASBLY
X7,X10	2	12 STAGE BINARY COUNTER
X11,X12,X40,X42	4	HC373A LATCH 3 STATE
X13,X14	2	HC259 DECODER
X15,X21,X22	3	8 BIT SHIFT REG
X16	1	8-BIT MPU D/A
X17,X18	2	HC4351 8 CHAN ANALOG MUX
X19,X24	2	HC109 FLIP FLOP
X20,X38	2	2 INPUT NAND GATE QUAD
X25	1	NPN DARLINGTON ARRAY
X26	1	224N QUAD OP AMP
X27	1	OP-27GZ OP AMP
X28,X29,X31	3	33074A OP AMP
X30	1	HC4066
X32	1	HC04A INVERTER
X33	1	431 I VOLT REF
X34	1	AC04 INVERTER
X35	1	AC139 DECODER
X36	1	AC373 3 STATE LATCH
X37	1	AC138 DECODER
X39,X41	2	HC74 FLIP FLOP
Y1	1	19.66 mHz.

CAPACITORS = MFD/VOLTS
 RESISTORS = OHMS/1/4 WATT UNLESS OTHERWISE SPECIFIED.
 INDUCTANCE = HENRYS

NOTE: Lincoln Electric assumes no responsibility for liabilities resulting from board level troubleshooting. PC Board repairs will invalidate your factory warranty. **Individual Printed Circuit Board Components are not available from Lincoln Electric.** This information is provided for reference only. Lincoln Electric discourages board level troubleshooting and repair since it may compromise the quality of the design and may result in danger to the Machine Operator or Technician. Improper PC board repairs could result in damage to the machine.



Return to Section TOC

Return to Master TOC

Return to Section TOC

Return to Master TOC

Return to Section TOC

Return to Master TOC

Return to Section TOC

Return to Master TOC

Meter PC Board (M15893) Layout

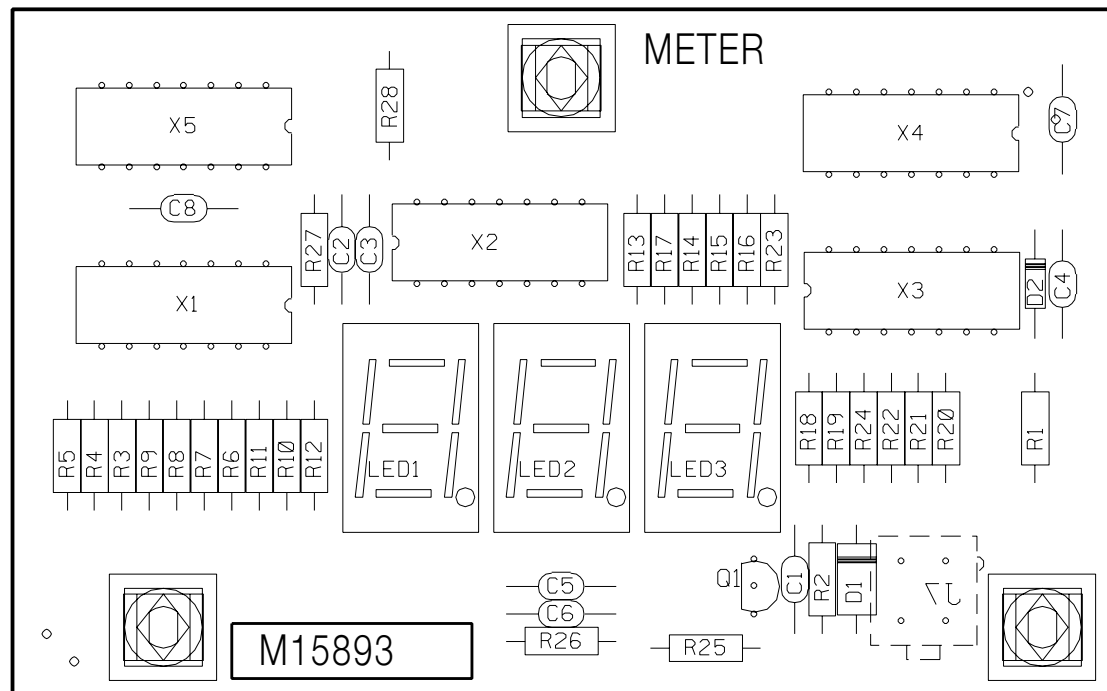

ITEM	REQ'D	IDENTIFICATION
C1,C2,C3,C4,C7,C8	6	.022/50
C5,C6	2	330pf/100
D1	1	1N4004
D2	1	1N914
J7	1	HEADER
LED1,LED2,LED3	3	LED DISPLAY
Q1	1	
R1	1	475 1/4W
R2	1	3.32K 1/4W
R3,R4,R5,R6,R7,R8,R9, R10,R11,R12,R13,R14,R15, R16,R17,R18,R19,R20,R21, R22,R23,R24,R25,R26	24	100 1/4W
R27,R28	2	3.01 1/4W
X1,X2,X3	3	S.S.
X4	1	S.S.
X5	1	S.S.

M15893

NOTE: Lincoln Electric assumes no responsibility for liabilities resulting from board level troubleshooting. PC Board repairs will invalidate your factory warranty. **Individual Printed Circuit Board Components are not available from Lincoln Electric.** This information is provided for reference only. Lincoln Electric discourages board level troubleshooting and repair since it may compromise the quality of the design and may result in danger to the Machine Operator or Technician. Improper PC board repairs could result in damage to the machine.



Return to Section TOC Return to Master TOC

Free Manuals Download Website

<http://myh66.com>

<http://usermanuals.us>

<http://www.somanuals.com>

<http://www.4manuals.cc>

<http://www.manual-lib.com>

<http://www.404manual.com>

<http://www.luxmanual.com>

<http://aubethermostatmanual.com>

Golf course search by state

<http://golfingnear.com>

Email search by domain

<http://emailbydomain.com>

Auto manuals search

<http://auto.somanuals.com>

TV manuals search

<http://tv.somanuals.com>