

POWER MIG 255C

For use with machines having Code Number : 11192, 11218

Safety Depends on You

Lincoln arc welding and cutting equipment is designed and built with safety in mind. However, your overall safety can be increased by proper installation . . . and thoughtful operation on your part. **DO NOT INSTALL, OPERATE OR REPAIR THIS EQUIPMENT WITHOUT READING THIS MANUAL AND THE SAFETY PRECAUTIONS CONTAINED THROUGHOUT.** And, most importantly, think before you act and be careful.

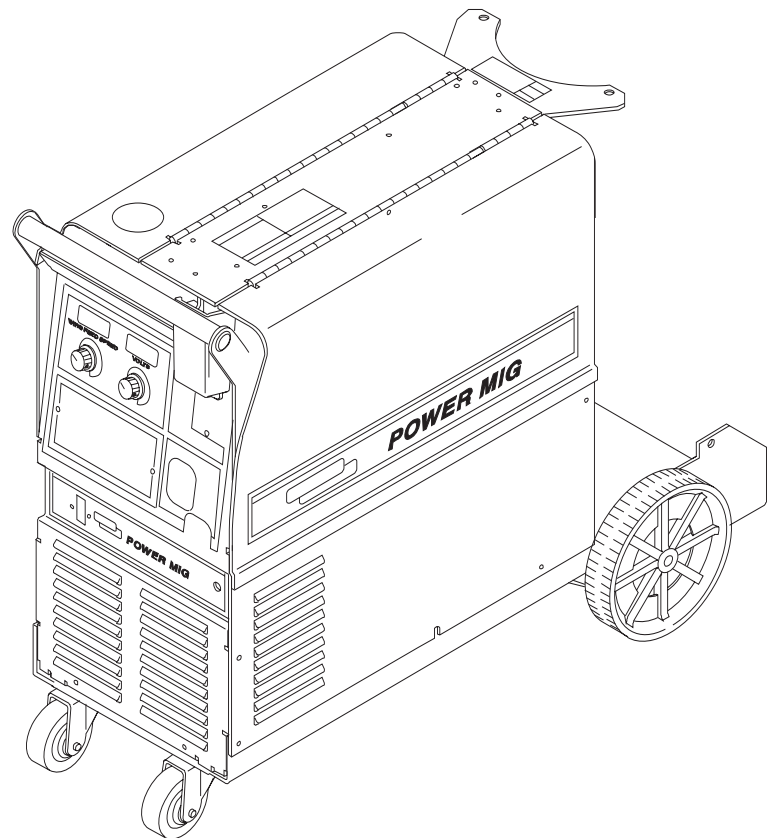

SERVICE MANUAL

LINCOLN[®]
ELECTRIC

Copyright © 2006 Lincoln Global Inc.

• World's Leader in Welding and Cutting Products •

• Sales and Service through Subsidiaries and Distributors Worldwide •

Cleveland, Ohio 44117-1199 U.S.A. TEL: 216.481.8100 FAX: 216.486.1751 WEB SITE: www.lincolnelectric.com

Download from Www.Somanuals.com. All Manuals Search And Download.

⚠ WARNING

⚠ CALIFORNIA PROPOSITION 65 WARNINGS ⚠

Diesel engine exhaust and some of its constituents are known to the State of California to cause cancer, birth defects, and other reproductive harm.

The Above For Diesel Engines

The engine exhaust from this product contains chemicals known to the State of California to cause cancer, birth defects, or other reproductive harm.

The Above For Gasoline Engines

ARC WELDING CAN BE HAZARDOUS. PROTECT YOURSELF AND OTHERS FROM POSSIBLE SERIOUS INJURY OR DEATH. KEEP CHILDREN AWAY. PACEMAKER WEARERS SHOULD CONSULT WITH THEIR DOCTOR BEFORE OPERATING.

Read and understand the following safety highlights. For additional safety information, it is strongly recommended that you purchase a copy of "Safety in Welding & Cutting - ANSI Standard Z49.1" from the American Welding Society, P.O. Box 351040, Miami, Florida 33135 or CSA Standard W117.2-1974. A Free copy of "Arc Welding Safety" booklet E205 is available from the Lincoln Electric Company, 22801 St. Clair Avenue, Cleveland, Ohio 44117-1199.

BE SURE THAT ALL INSTALLATION, OPERATION, MAINTENANCE AND REPAIR PROCEDURES ARE PERFORMED ONLY BY QUALIFIED INDIVIDUALS.



FOR ENGINE powered equipment.

1.a. Turn the engine off before troubleshooting and maintenance work unless the maintenance work requires it to be running.



1.b. Operate engines in open, well-ventilated areas or vent the engine exhaust fumes outdoors.



1.c. Do not add the fuel near an open flame welding arc or when the engine is running. Stop the engine and allow it to cool before refueling to prevent spilled fuel from vaporizing on contact with hot engine parts and igniting. Do not spill fuel when filling tank. If fuel is spilled, wipe it up and do not start engine until fumes have been eliminated.

1.d. Keep all equipment safety guards, covers and devices in position and in good repair. Keep hands, hair, clothing and tools away from V-belts, gears, fans and all other moving parts when starting, operating or repairing equipment.

1.e. In some cases it may be necessary to remove safety guards to perform required maintenance. Remove guards only when necessary and replace them when the maintenance requiring their removal is complete. Always use the greatest care when working near moving parts.



1.f. Do not put your hands near the engine fan. Do not attempt to override the governor or idler by pushing on the throttle control rods while the engine is running.

1.g. To prevent accidentally starting gasoline engines while turning the engine or welding generator during maintenance work, disconnect the spark plug wires, distributor cap or magneto wire as appropriate.



1.h. To avoid scalding, do not remove the radiator pressure cap when the engine is hot.



ELECTRIC AND MAGNETIC FIELDS may be dangerous

2.a. Electric current flowing through any conductor causes localized Electric and Magnetic Fields (EMF). Welding current creates EMF fields around welding cables and welding machines

2.b. EMF fields may interfere with some pacemakers, and welders having a pacemaker should consult their physician before welding.

2.c. Exposure to EMF fields in welding may have other health effects which are now not known.

2.d. All welders should use the following procedures in order to minimize exposure to EMF fields from the welding circuit:

2.d.1. Route the electrode and work cables together - Secure them with tape when possible.

2.d.2. Never coil the electrode lead around your body.

2.d.3. Do not place your body between the electrode and work cables. If the electrode cable is on your right side, the work cable should also be on your right side.

2.d.4. Connect the work cable to the workpiece as close as possible to the area being welded.

2.d.5. Do not work next to welding power source.

Mar '95



ELECTRIC SHOCK can kill.

3.a. The electrode and work (or ground) circuits are electrically "hot" when the welder is on. Do not touch these "hot" parts with your bare skin or wet clothing. Wear dry, hole-free gloves to insulate hands.

3.b. Insulate yourself from work and ground using dry insulation. Make certain the insulation is large enough to cover your full area of physical contact with work and ground.

In addition to the normal safety precautions, if welding must be performed under electrically hazardous conditions (in damp locations or while wearing wet clothing; on metal structures such as floors, gratings or scaffolds; when in cramped positions such as sitting, kneeling or lying, if there is a high risk of unavoidable or accidental contact with the workpiece or ground) use the following equipment:

- Semiautomatic DC Constant Voltage (Wire) Welder.
- DC Manual (Stick) Welder.
- AC Welder with Reduced Voltage Control.

3.c. In semiautomatic or automatic wire welding, the electrode, electrode reel, welding head, nozzle or semiautomatic welding gun are also electrically "hot".

3.d. Always be sure the work cable makes a good electrical connection with the metal being welded. The connection should be as close as possible to the area being welded.

3.e. Ground the work or metal to be welded to a good electrical (earth) ground.

3.f. Maintain the electrode holder, work clamp, welding cable and welding machine in good, safe operating condition. Replace damaged insulation.

3.g. Never dip the electrode in water for cooling.

3.h. Never simultaneously touch electrically "hot" parts of electrode holders connected to two welders because voltage between the two can be the total of the open circuit voltage of both welders.

3.i. When working above floor level, use a safety belt to protect yourself from a fall should you get a shock.

3.j. Also see Items 6.c. and 8.



ARC RAYS can burn.

4.a. Use a shield with the proper filter and cover plates to protect your eyes from sparks and the rays of the arc when welding or observing open arc welding. Headshield and filter lens should conform to ANSI Z87.1 standards.

4.b. Use suitable clothing made from durable flame-resistant material to protect your skin and that of your helpers from the arc rays.

4.c. Protect other nearby personnel with suitable, non-flammable screening and/or warn them not to watch the arc nor expose themselves to the arc rays or to hot spatter or metal.



FUMES AND GASES can be dangerous.

5.a. Welding may produce fumes and gases hazardous to health. Avoid breathing these fumes and gases. When welding, keep your head out of the fume. Use enough ventilation and/or exhaust at the arc to keep

fumes and gases away from the breathing zone. **When welding with electrodes which require special ventilation such as stainless or hard facing (see instructions on container or MSDS) or on lead or cadmium plated steel and other metals or coatings which produce highly toxic fumes, keep exposure as low as possible and below Threshold Limit Values (TLV) using local exhaust or mechanical ventilation. In confined spaces or in some circumstances, outdoors, a respirator may be required. Additional precautions are also required when welding on galvanized steel.**

5. b. The operation of welding fume control equipment is affected by various factors including proper use and positioning of the equipment, maintenance of the equipment and the specific welding procedure and application involved. Worker exposure level should be checked upon installation and periodically thereafter to be certain it is within applicable OSHA PEL and ACGIH TLV limits.

5.c. Do not weld in locations near chlorinated hydrocarbon vapors coming from degreasing, cleaning or spraying operations. The heat and rays of the arc can react with solvent vapors to form phosgene, a highly toxic gas, and other irritating products.

5.d. Shielding gases used for arc welding can displace air and cause injury or death. Always use enough ventilation, especially in confined areas, to insure breathing air is safe.

5.e. Read and understand the manufacturer's instructions for this equipment and the consumables to be used, including the material safety data sheet (MSDS) and follow your employer's safety practices. MSDS forms are available from your welding distributor or from the manufacturer.

5.f. Also see item 1.b.

AUG 06

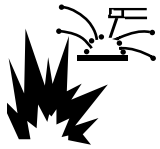

WELDING SPARKS can cause fire or explosion.

6.a. Remove fire hazards from the welding area. If this is not possible, cover them to prevent the welding sparks from starting a fire.

Remember that welding sparks and hot materials from welding can easily go through small cracks and openings to adjacent areas. Avoid welding near hydraulic lines. Have a fire extinguisher readily available.

- 6.b. Where compressed gases are to be used at the job site, special precautions should be used to prevent hazardous situations. Refer to "Safety in Welding and Cutting" (ANSI Standard Z49.1) and the operating information for the equipment being used.
- 6.c. When not welding, make certain no part of the electrode circuit is touching the work or ground. Accidental contact can cause overheating and create a fire hazard.
- 6.d. Do not heat, cut or weld tanks, drums or containers until the proper steps have been taken to insure that such procedures will not cause flammable or toxic vapors from substances inside. They can cause an explosion even though they have been "cleaned". For information, purchase "Recommended Safe Practices for the Preparation for Welding and Cutting of Containers and Piping That Have Held Hazardous Substances", AWS F4.1 from the American Welding Society (see address above).
- 6.e. Vent hollow castings or containers before heating, cutting or welding. They may explode.
- 6.f. Sparks and spatter are thrown from the welding arc. Wear oil free protective garments such as leather gloves, heavy shirt, cuffless trousers, high shoes and a cap over your hair. Wear ear plugs when welding out of position or in confined places. Always wear safety glasses with side shields when in a welding area.
- 6.g. Connect the work cable to the work as close to the welding area as practical. Work cables connected to the building framework or other locations away from the welding area increase the possibility of the welding current passing through lifting chains, crane cables or other alternate circuits. This can create fire hazards or overheat lifting chains or cables until they fail.
- 6.h. Also see item 1.c.

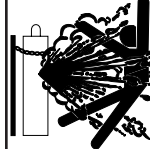

CYLINDER may explode if damaged.

7.a. Use only compressed gas cylinders containing the correct shielding gas for the process used and properly operating regulators designed for the gas and pressure used. All hoses, fittings, etc. should be suitable for the application and maintained in good condition.

- 7.b. Always keep cylinders in an upright position securely chained to an undercarriage or fixed support.
- 7.c. Cylinders should be located:
 - Away from areas where they may be struck or subjected to physical damage.
 - A safe distance from arc welding or cutting operations and any other source of heat, sparks, or flame.
- 7.d. Never allow the electrode, electrode holder or any other electrically "hot" parts to touch a cylinder.
- 7.e. Keep your head and face away from the cylinder valve outlet when opening the cylinder valve.
- 7.f. Valve protection caps should always be in place and hand tight except when the cylinder is in use or connected for use.
- 7.g. Read and follow the instructions on compressed gas cylinders, associated equipment, and CGA publication P-1, "Precautions for Safe Handling of Compressed Gases in Cylinders," available from the Compressed Gas Association 1235 Jefferson Davis Highway, Arlington, VA 22202.



FOR ELECTRICALLY powered equipment.

- 8.a. Turn off input power using the disconnect switch at the fuse box before working on the equipment.
- 8.b. Install equipment in accordance with the U.S. National Electrical Code, all local codes and the manufacturer's recommendations.
- 8.c. Ground the equipment in accordance with the U.S. National Electrical Code and the manufacturer's recommendations.

Mar '95

PRÉCAUTIONS DE SÛRETÉ

Pour votre propre protection lire et observer toutes les instructions et les précautions de sûreté spécifiques qui paraissent dans ce manuel aussi bien que les précautions de sûreté générales suivantes:

Sûreté Pour Soudage A L'Arc

1. Protégez-vous contre la secousse électrique:
 - a. Les circuits à l'électrode et à la pièce sont sous tension quand la machine à souder est en marche. Eviter toujours tout contact entre les parties sous tension et la peau nue ou les vêtements mouillés. Porter des gants secs et sans trous pour isoler les mains.
 - b. Faire très attention de bien s'isoler de la masse quand on soude dans des endroits humides, ou sur un plancher métallique ou des grilles métalliques, principalement dans les positions assis ou couché pour lesquelles une grande partie du corps peut être en contact avec la masse.
 - c. Maintenir le porte-électrode, la pince de masse, le câble de soudage et la machine à souder en bon et sûr état de fonctionnement.
 - d. Ne jamais plonger le porte-électrode dans l'eau pour le refroidir.
 - e. Ne jamais toucher simultanément les parties sous tension des porte-électrodes connectés à deux machines à souder parce que la tension entre les deux pinces peut être le total de la tension à vide des deux machines.
 - f. Si on utilise la machine à souder comme une source de courant pour soudage semi-automatique, ces précautions pour le porte-électrode s'appliquent aussi au pistolet de soudage.
2. Dans le cas de travail au dessus du niveau du sol, se protéger contre les chutes dans le cas où on reçoit un choc. Ne jamais enrouler le câble-électrode autour de n'importe quelle partie du corps.
3. Un coup d'arc peut être plus sévère qu'un coup de soliel, donc:
 - a. Utiliser un bon masque avec un verre filtrant approprié ainsi qu'un verre blanc afin de se protéger les yeux du rayonnement de l'arc et des projections quand on soude ou quand on regarde l'arc.
 - b. Porter des vêtements convenables afin de protéger la peau de soudeur et des aides contre le rayonnement de l'arc.
 - c. Protéger l'autre personnel travaillant à proximité au soudage à l'aide d'écrans appropriés et non-inflammables.
4. Des gouttes de laitier en fusion sont émises de l'arc de soudage. Se protéger avec des vêtements de protection libres de l'huile, tels que les gants en cuir, chemise épaisse, pantalons sans revers, et chaussures montantes.
5. Toujours porter des lunettes de sécurité dans la zone de soudage. Utiliser des lunettes avec écrans latéraux dans les

zones où l'on pique le laitier.

6. Eloigner les matériaux inflammables ou les recouvrir afin de prévenir tout risque d'incendie dû aux étincelles.
7. Quand on ne soude pas, poser la pince à un endroit isolé de la masse. Un court-circuit accidentel peut provoquer un échauffement et un risque d'incendie.
8. S'assurer que la masse est connectée le plus près possible de la zone de travail qu'il est pratique de le faire. Si on place la masse sur la charpente de la construction ou d'autres endroits éloignés de la zone de travail, on augmente le risque de voir passer le courant de soudage par les chaînes de levage, câbles de grue, ou autres circuits. Cela peut provoquer des risques d'incendie ou d'échauffement des chaînes et des câbles jusqu'à ce qu'ils se rompent.
9. Assurer une ventilation suffisante dans la zone de soudage. Ceci est particulièrement important pour le soudage de tôles galvanisées plombées, ou cadmiées ou tout autre métal qui produit des fumées toxiques.
10. Ne pas souder en présence de vapeurs de chlore provenant d'opérations de dégraissage, nettoyage ou pistologie. La chaleur ou les rayons de l'arc peuvent réagir avec les vapeurs du solvant pour produire du phosgène (gas fortement toxique) ou autres produits irritants.
11. Pour obtenir de plus amples renseignements sur la sûreté, voir le code "Code for safety in welding and cutting" CSA Standard W 117.2-1974.

PRÉCAUTIONS DE SÛRETÉ POUR LES MACHINES À SOUDER À TRANSFORMATEUR ET À REDRESSEUR

1. Relier à la terre le châssis du poste conformément au code de l'électricité et aux recommandations du fabricant. Le dispositif de montage ou la pièce à souder doit être branché à une bonne mise à la terre.
2. Autant que possible, l'installation et l'entretien du poste seront effectués par un électricien qualifié.
3. Avant de faire des travaux à l'intérieur de poste, la débrancher à l'interrupteur à la boîte de fusibles.
4. Garder tous les couvercles et dispositifs de sûreté à leur place.

MASTER TABLE OF CONTENTS FOR ALL SECTIONS

	Page
Safety	i-iv
Installation	Section A
Operation	Section B
Accessories	Section C
Maintenance	Section D
Theory of Operation	Section E
Troubleshooting and Repair	Section F
Electrical Diagrams	Section G
Parts Manual	P-514

TABLE OF CONTENTS
-INSTALLATION SECTION-

Installation	Section A
Technical Specifications — POWER MIG 255C	A-2
Safety Precautions	A-3
Uncrating the POWER MIG 255C	A-3
Location	A-3
Input Power, Grounding and Connection Diagrams	A-3
Dual Voltage Machine Input Connections	A-4
Triple Voltage Machine Input Connections	A-5
Output Polarity Connections	A-5
Gun and Cable Installation	A-6
Shielding Gas	A-6
Auxiliary Power Receptacles	A-6

Return to Master TOC

Return to Master TOC

Return to Master TOC

Return to Master TOC

POWER MIG 255C



TECHNICAL SPECIFICATIONS – POWER MIG 255C

INPUT – SINGLE PHASE ONLY

<u>Standard Voltage/Frequency</u>	<u>Input Current @ 200 Amp Rated Output</u>	<u>Input Current @ 250 Amp Rated Output</u>
208/230/60 Hz	*47/44 Amps	56/52
230/460/575/60 Hz	41/20/16 Amps	50/24/19

RATED OUTPUT

<u>Duty Cycle</u>	<u>Amps</u>	<u>Volts at Rated Amperes</u>
40%	250 Amps	26 Volts
60%	200 Amps	28 Volts
100%	145 Amps	26 Volts

OUTPUT

<u>Welding Current Range (Continuous)</u>	<u>Maximum Open Circuit Voltage</u>	<u>Welding Voltage Range</u>
30 – 300 Amps	40 Volts	10-28 Volts

RECOMMENDED INPUT WIRE AND FUSE SIZES

<u>Input Voltage/ Frequency (Hz)</u>	<u>Fuse or Breaker Size (Super Lag)</u>	<u>Input Ampere Rating On Nameplate</u>	<u>75°C Copper Wire in Conduit AWG (IEC) Sizes (For lengths up to 100 ft)</u>	<u>75°C Copper Wire in Conduit AWG (IEC) Sizes (For lengths exceeding 100 ft)</u>
208/60	60	56	8 (10 mm ²)	6 (16 mm ²)
230/60	60	52	10 (6 mm ²)	8 (10 mm ²)
460/60	30	24	14 (2.5 mm ²)	12 (4 mm ²)
575/60	25	19	14 (2.5 mm ²)	12 (4 mm ²)

NOTE: Use #10 AWG Grounding Wire

PHYSICAL DIMENSIONS

<u>Height</u>	<u>Width</u>	<u>Depth</u>	<u>Weight</u>
31.79 in.	18.88 in.	38.78 in.	220 lbs
808 mm	480 mm	985 mm	100 kg

WIRE SPEED RANGE

<u>Wire Speed</u>	50 – 700 IPM (1.27 – 17.8 m/minute)
-------------------	-------------------------------------

POWER MIG 255C



Read entire installation section before starting installation.

SAFETY PRECAUTIONS

⚠ WARNING



ELECTRIC SHOCK can kill.

- Only qualified personnel should perform this installation.
- Only personnel that have read and understood the POWER MIG 255C Operating Manual should install and operate this equipment.
- Machine must be grounded per any national, local or other applicable electrical codes.
- The POWER MIG power switch is to be in the OFF position when installing work cable and gun and when connecting other equipment.

UNCRATING THE POWER MIG 255C

Cut banding and lift off cardboard carton. Cut banding holding the machine to the skid. Remove foam and corrugated packing material. Untape accessories from Gas Bottle Platform. Unscrew the two wood screws (at the Gas Bottle Platform) holding the machine to the skid. Roll the machine off the skid assembly.

LOCATION

Locate the welder in a dry location where there is free circulation of clean air into the louvers in the back and out the front. A location that minimizes the amount of smoke and dirt drawn into the rear louvers reduces the chance of dirt accumulation that can block air passages and cause overheating.

INPUT POWER, GROUNDING AND CONNECTION DIAGRAMS

⚠ WARNING



ELECTRIC SHOCK can kill.

- Do not touch electrically live parts such as output terminals or internal wiring.
- All input power must be electrically disconnected before proceeding.

1. Before starting the installation, check with the local power company if there is any question about whether your power supply is adequate for the voltage, amperes, phase, and frequency specified on the welder nameplate. Also be sure the planned installation will meet the U.S. National Electrical Code and local code requirements. This welder may be operated from a single phase line or from one phase of a two or three phase line.
2. Models that have multiple input voltages specified on the nameplate (e.g. 208/230) are shipped connected for the highest voltage. If the welder is to be operated on lower voltage, it must be reconnected according to the instructions in *Figure A.1* for dual voltage machines and *Figure A.2* for triple voltage machines.

⚠ WARNING

Make certain that the input power is electrically disconnected before removing the screw on the reconnect panel access cover.

FIGURE A.1 — DUAL VOLTAGE MACHINE INPUT CONNECTIONS.

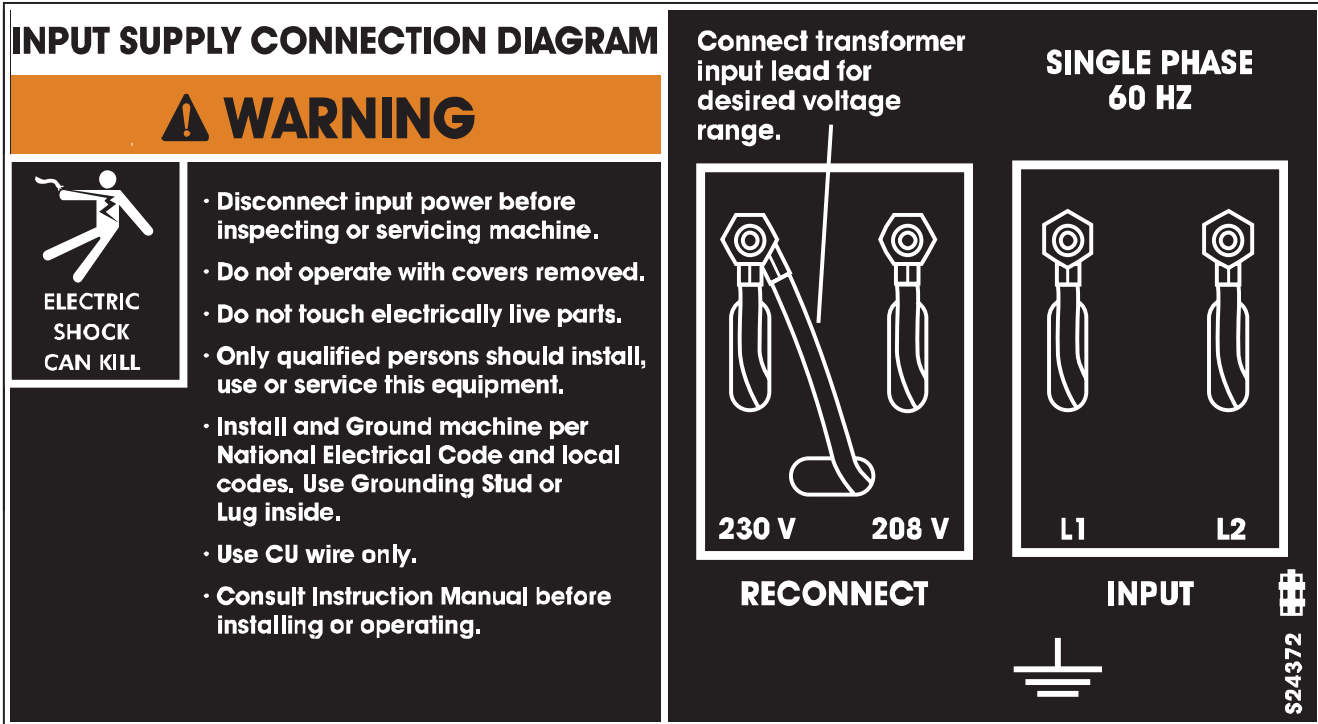

3. The 208/230 volt 60 Hz model POWER MIG is shipped with a 10 ft. input cable and plug connected to the welder. A matching receptacle is supplied with the machine. Mount the receptacle in a suitable location using the screws provided. Be sure it can be reached by the plug on the input cable attached to the welder. Mount with the grounding terminal at the top to allow the power cable to hang down without bending.

The 230/460/575 volt 60 Hz model is not equipped with a plug, an input cable, or a receptacle.

4. Using the instructions in **Figure A.3**, have a qualified electrician connect the receptacle or cable to the input power lines and the system ground per the U.S. National Electrical Code and any applicable local codes. See **Technical Specifications** at the beginning of this chapter for proper wire sizes. For long runs over 100 feet, larger copper wires should be used. Fuse the two hot lines with super lag type fuses as shown in the following diagram. The center contact in the receptacle is for the grounding connection. A green wire in the input cable connects this contact to the frame of the welder. This ensures proper grounding of the welder frame when the welder plug is inserted into the receptacle.

FIGURE A.2 — TRIPLE VOLTAGE MACHINE INPUT CONNECTIONS.

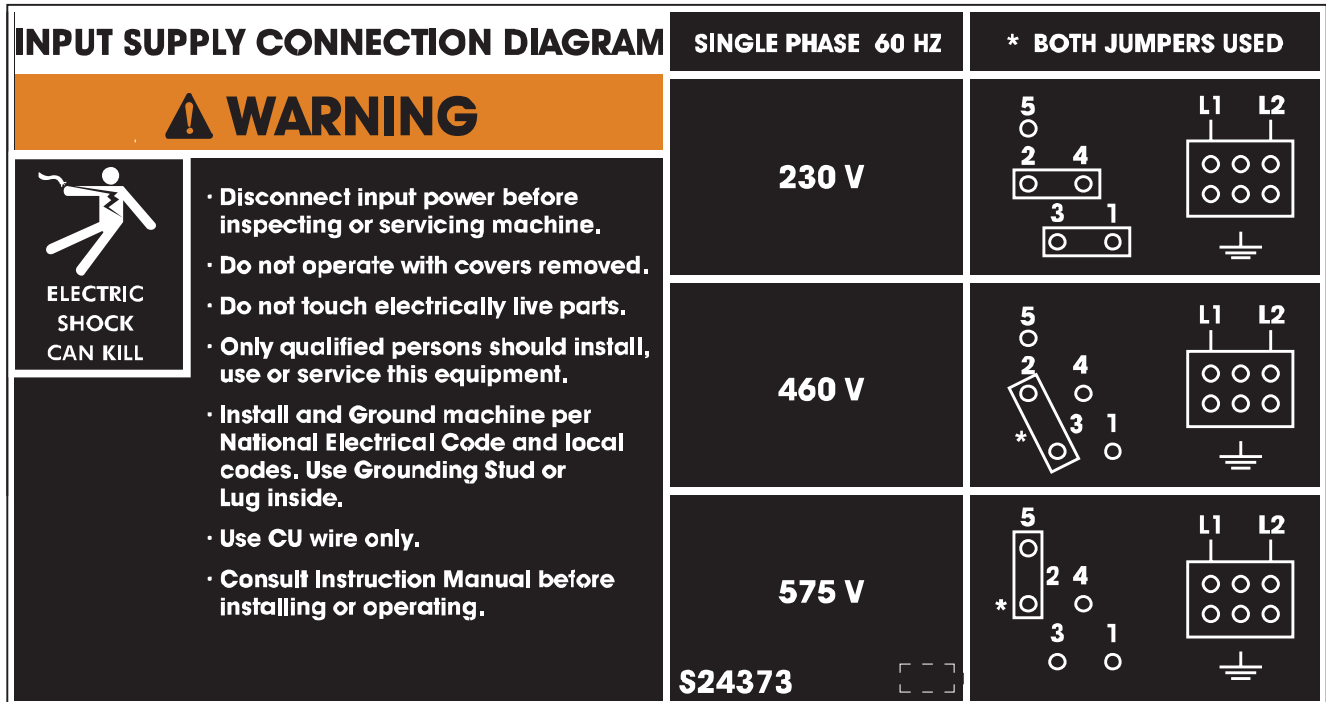
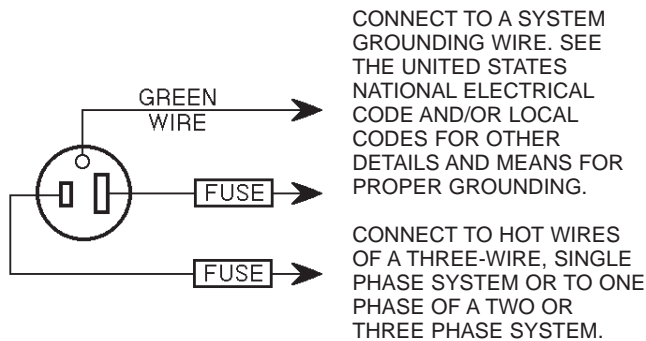

FIGURE A.3 — RECEPTACLE DIAGRAM.



OUTPUT POLARITY CONNECTIONS

The welder, as shipped from the factory, is connected for electrode positive (+) polarity. This is the normal polarity for GMA welding.

If negative (-) polarity is required, interchange the connection of the two cables located in the wire drive compartment near the front panel. The electrode cable, which is attached to the wire drive, is to be connected to the negative (-) labeled terminal. The work lead, which is attached to the work clamp, is to be connected to the positive (+) labeled terminal.

Return to Section TOC

Return to Section TOC

Return to Section TOC

Return to Section TOC

Return to Master TOC

Return to Master TOC

Return to Master TOC

Return to Master TOC

GUN AND CABLE INSTALLATION

The Magnum 250L gun and cable provided with the POWER MIG 255C is factory installed with a liner for 0.035-0.045 in. (0.9-1.2 mm) electrode and an 0.035 in. (0.9 mm) contact tip. Install the 0.045 tip (also provided) if this wire size is being used.

WARNING

Turn the welder power switch off before installing gun and cable.

1. Lay the cable out straight.
2. Unscrew knurled screw on the drive unit front end (inside wire feed compartment) until tip of screw no longer protrudes into gun opening as seen from front of machine.
3. Insert the male end of gun cable into the female casting through opening in front panel. Make sure connector is fully inserted and tighten knurled screw.
4. Connect the gun trigger connector from the gun and cable to the mating receptacle inside the compartment located above the gun connection made in item 3 above. Make sure that the keyways are aligned, insert and tighten retaining ring.

SHIELDING GAS

(For Gas Metal Arc Welding Processes)

Customer must provide cylinder of appropriate type shielding gas for the process being used.

A gas flow regulator, for CO₂ or Argon blend gas, and an inlet gas hose are factory provided with the POWER MIG 255C. Install the shielding gas supply as follows:

1. Set gas cylinder on rear platform of POWER MIG 255C. Hook chain in place to secure cylinder to rear of welder.
2. Remove the cylinder cap. Inspect the cylinder valves and regulator for damaged threads, dirt, dust, oil or grease. Remove dust and dirt with a clean cloth.

DO NOT ATTACH THE REGULATOR IF OIL, GREASE OR DAMAGE IS PRESENT! Inform your gas supplier of this condition. Oil or grease in the presence of high pressure oxygen is explosive.

WARNING

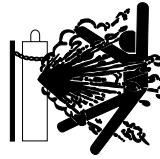

CYLINDER may explode if damaged.

- Gas under pressure is explosive. Always keep gas cylinders in an upright position and always keep chained to undercarriage or stationary support. See American National Standard Z-49.1, "Safety in Welding and Cutting" published by the American Welding Society.

3. Stand to one side away from the outlet and open the cylinder valve for an instant. This blows away any dust or dirt which may have accumulated in the valve outlet.

WARNING

Be sure to keep your face away from the valve outlet when "cracking" the valve.

4. Attach the flow regulator to the cylinder valve and tighten the union nut(s) securely with a wrench.

NOTE: If connecting to 100% CO₂ cylinder, insert regulator adapter between regulator and cylinder valve. If adapter is equipped with a plastic washer, be sure it is seated for connection to the CO₂ cylinder.

5. Attach one end of the inlet gas hose to the outlet fitting of the flow regulator, the other end to the POWER MIG 255C rear fitting, and tighten the union nuts securely with a wrench.
6. Before opening the cylinder valve, turn the regulator adjusting knob counterclockwise until the adjusting spring pressure is released.
7. Standing to one side, open the cylinder valve slowly a fraction of a turn. When the cylinder pressure gauge pointer stops moving, open the valve fully.

WARNING

Never stand directly in front of or behind the flow regulator when opening the cylinder valve. Always stand to one side.

8. The flow regulator is adjustable. Adjust it to the flow rate recommended for the procedure and process being used before making the weld.

AUXILIARY POWER RECEPTACLES

(For 208/230V Models only)

This machine is equipped with 15Amp 120V receptacle with 15Amp Circuit Breaker. The receptacle is UL and CSA approved.

POWER MIG 255C



TABLE OF CONTENTS -OPERATION SECTION-

Operation	Section B
Product Description	B-3
Recommended Processes and Equipment	B-3
Description of Controls	B-4
Wire Drive Roll	B-4
Wire Size Conversion Parts	B-4
Procedure for Changing Drive and Idle Roll Sets	B-5
Wire Reel Loading - Readi-Reels, Spools, or Coils	B-5
To Mount a 30 lb (14 kg) Readi-Reel Package (Using the Molded Plastic K363-P Readi-Reel Adapter)	B-5
To Mount 10 to 44 lb (4.5-20 kg) Spools (12 in./300 mm Diameter) or 14 lb (6 kg) Innershield Coils	B-5
To Start the Welder	B-6
Feeding Wire Electrode	B-6
Idle Roll Pressure Setting	B-6
Wire Drive Configuration	B-6/B-7
Setting Run-In Speed on Standard Power MIG Feeder	B-8
Fast or Slow Run-In Mode Selection (When Timer Option is not Installed)	B-8
Instructions to Enter Slow Run-In	B-8
Instructions to Enter Fast Run-In	B-8
Making a Weld	B-8
Avoiding Wire Feeding Problems	B-9
Fan Control	B-9
Input Line Voltage Protection	B-9
Wire Feed Overload Protection	B-9
Welding Thermal Overload Protection	B-10
Overcurrent Protection	B-10

Return to Master TOC

Return to Master TOC

Return to Master TOC

Return to Master TOC

POWER MIG 255C



Read entire Operation section before operating the POWER MIG 255C.

WARNING



ELECTRIC SHOCK can kill.

- Do not touch electrically live parts or electrode with skin or wet clothing. Insulate yourself from work and ground.
- Always wear dry insulating gloves.



FUMES AND GASES can be dangerous.

- Keep your head out of fumes.
- Use ventilation or exhaust to remove fumes from breathing zone.



WELDING SPARKS can cause fire or explosion.

- Keep flammable material away.
- Do not weld on closed containers.



ARC RAYS can burn eyes and skin.

- Wear eye, ear and body protection.

Observe all safety information throughout this manual.

POWER MIG 255C



PRODUCT DESCRIPTION

The POWER MIG™ 255C is a complete semiautomatic constant voltage DC arc welding machine built to meet NEMA specifications. It combines a constant voltage power source and a constant speed wire feeder with a microcomputer-based controller to form a reliable high-performance welding system. A simple control scheme, consisting of continuous full range voltage and wire feed speed controls, provides versatility with ease of use and accuracy. The POWER MIG™ 255C is Spool Gun ready and includes a second Gas Solenoid for Spool Gun use. Refer to **Accessories Section** for Applicable Spool Guns.

Other features include a 2" (51 mm) O.D. wire reel spindle with adjustable brake, an integral gas cylinder mounting undercarriage, an adjustable CO₂ or Argon blend flow regulator with cylinder pressure gauge and inlet hose, a 15 ft. (4.6 m) Magnum 250L GMAW gun and cable with fixed (flush) nozzle, a 10 ft. (3.0 m) power cable with plug and mating receptacle, and a 10 ft. (3.0 m) work cable with clamp.

An Optional Timer kit provides variable burnback control, a spot function, a selectable 4-step trigger interlock and adjustable "Run In" for wire starting optimization. Also optional are a Dual Cylinder Mounting kit and an Aluminum Feeding Kit for push feeding with standard built in feeder.

RECOMMENDED PROCESSES AND EQUIPMENT

The POWER MIG 255C is recommended for GMA welding processes using 10 to 44 lb (4.5 to 20 kg) 2" (51 mm) I.D. spools or Readi-Reel® coils (with optional adapter) of .025" through .045" (0.6 – 1.2 mm) solid steel, .035" (0.9 mm) stainless, 3/64" (1.2 mm) aluminum and .045" (1.2 mm) Outershield®; as well as .035" (0.9 mm) and .045" (1.2 mm) Innershield® self-shielding electrodes.

The POWER MIG 255C is factory equipped to feed .035" (0.9 mm) and .045(1.2mm) electrode. It also includes a 200A, 60% duty cycle (or 250A, 40% duty cycle) rated, 15 ft. (4.6 m) GMAW gun and cable assembly equipped for these wire sizes. Use of GMAW processes requires a supply of shielding gas.

WARNING

WELDING CAPABILITY

The POWER MIG 255C is rated at 250 amps @ 26 volts, at a 40% duty cycle based on a ten minute cycle time. It is capable of higher duty cycles at lower output currents and capable of up to 300 Amps at lower duty cycles.

LIMITATIONS

The POWER MIG 255C **WILL NOT operate** satisfactorily if powered with a portable or in-plant generating system.

POWER MIG 255C



DESCRIPTION OF CONTROLS

Power ON/OFF Switch — Place the lever in the "ON" position to energize the POWER MIG 255C. When the power is on, the red LED display lights illuminate.

Voltage Control — This is a continuous control that gives full range adjustment of power source output voltage. It can be adjusted while welding over its 10 to 28 volt range.

Wire Speed Control — This controls the wire feed speed from 50 – 700 inches per minute (1.2 – 17.8 m/min). The control can be preset on the dial to the setting specified on the Procedure Decal on the inside of the wire compartment door. Wire speed is not affected when changes are made in the voltage control.

WIRE DRIVE ROLL

The drive rolls installed with the POWER MIG 255C have two grooves one for .035(0.9mm) wire Solid Steel electrode and the other for .045(1.2mm) wire. Drive roll size is stenciled on each side of the drive roll. If feeding problems occur, check to make sure that the wire size and the drive roll size matches. See "**Procedure for Changing Drive Roll**" in this section. This infor-

mation also appears on the Procedure Decal on the door inside the wire compartment.

WIRE SIZE CONVERSION PARTS

The POWER MIG 255C is rated to feed .025 through .045" (0.6-1.2 mm) solid or cored electrode sizes.

The drive roll kits and Magnum 250L gun and cable parts are available to feed different sizes and types of electrodes. See **Accessories** section.

FIGURE B.1— OPERATOR CONTROLS

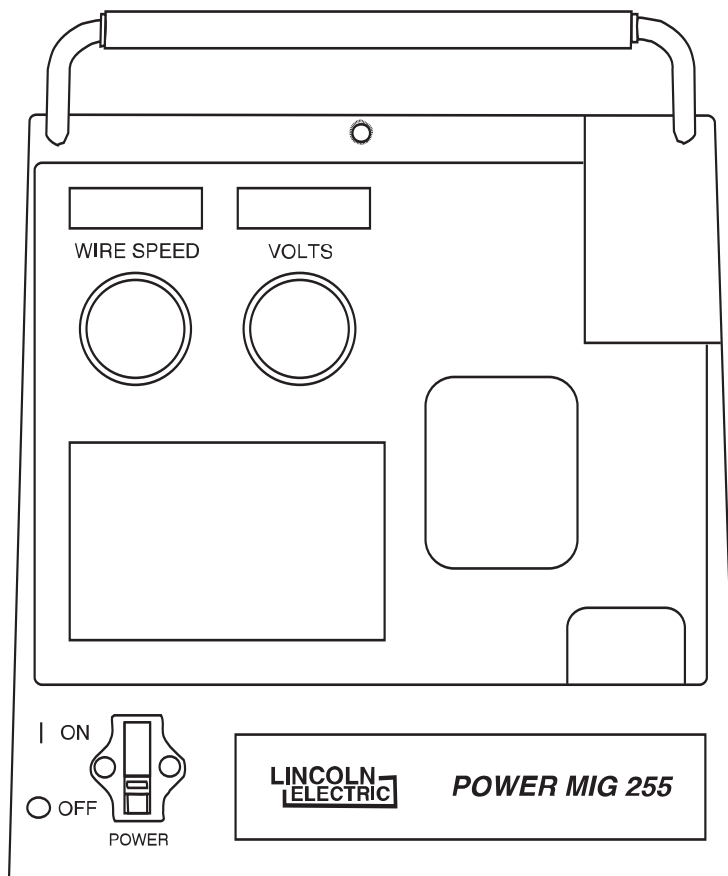

POWER MIG 255C



PROCEDURE FOR CHANGING DRIVE AND IDLE ROLL SETS

1. Turn off the power source.
2. Release the pressure on the idle roll by swinging the adjustable pressure arm down toward the back of the machine. Lift the cast idle roll assembly and allow it to sit in an upright position.
3. Remove the outside wire guide retaining plate by loosening the two large knurled screws.
4. Twist the drive roll retaining mechanism to the unlocked position as shown below and remove the drive roll. (See Figure B.2)

FIGURE B.2

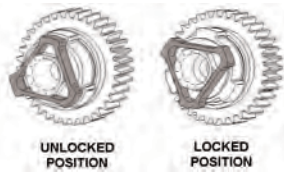

5. Remove the inside wire guide plate.
6. Replace the drive and idle rolls and inside wire guide with a set marked for the new wire size. **NOTE:** Be sure that the gun liner and contact tip are also sized to match the selected wire size.
7. Manually feed the wire from the wire reel, over the drive roll groove and through the wire guide and then into the brass bushing of the gun and cable assembly.
8. Replace the outside wire guide retaining plate by tightening the two large knurled screws. Reposition the adjustable pressure arm to its original position to apply pressure. Adjust pressure as necessary.

WIRE REEL LOADING - READI REELS, SPOOLS OR COILS

To Mount a 30 Lb. (14 kg) Read-Reel Package (Using the Molded Plastic K363-P Read-Reel Adapter:)

1. Open the Wire Drive Compartment Door
2. Depress the Release Bar on the Retaining Collar and remove it from the spindle.
3. Place the Optional Adapter on the spindle
4. Re-install the Retaining Collar. Make sure that the Release Bar "pops up" and that the collar retainers fully engage the retaining ring groove on the spindle.

5. Rotate the spindle and adapter so the retaining spring is at the 12 o'clock position.
6. Position the Read-Reel so that it will rotate in a direction when feeding so as to be de-reeled from top of the coil.
7. Set one of the Read-Reel inside cage wires on the slot in the retaining spring tab.
8. Lower the Read-Reel to depress the retaining spring and align the other inside cage wires with the grooves in the molded adapter.
9. Slide cage all the way onto the adapter until the retaining spring "pops up" fully.

⚠ WARNING

CHECK TO BE SURE THE RETAINING SPRING HAS FULLY RETURNED TO THE LOCKING POSITION AND HAS SECURELY LOCKED THE READI-REEL CAGE IN PLACE. RETAINING SPRING MUST REST ON THE CAGE, NOT THE WELDING ELECTRODE.

10. To remove Read-Reel from Adapter, depress retaining spring tab with thumb while pulling the Read-Reel cage from the molded adapter with both hands. Do not remove adapter from spindle.

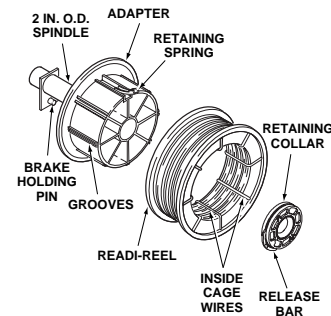

To Mount 10 to 44 Lb. (4.5-20 kg) Spools (12"/300 mm Diameter) or 14Lb.(6 Kg) Innershield Coils:

(For 13-14 lb. (6 Kg) Innershield coils, a K435 Coil Adapter must be used).

(For 10 lb.(4.5 Kg) 8 inch(203mm) diameter spools, a K468 spindle adapter must be used).

1. Open the Wire Drive Compartment Door
2. Depress the Release Bar on the Retaining Collar and remove it from the spindle.
3. Place the spool on the spindle making certain the spindle brake pin enters one of the holes in the back side of the spool (Note: an arrow mark on the spindle lines up with the brake holding pin to assist in lining up a hole). Be certain the wire comes off the reel in a direction so as to de-reel from the top of the coil.
4. Re-install the Retaining Collar. Make sure that the Release Bar "pops up" and that the collar retainers fully engage the retaining ring groove on the spindle.

POWER MIG 255C



TO START THE WELDER

Turn the Power Switch switch to ON. This lights the red LED display lights. With the desired voltage and wire speed selected, operate the gun trigger for welder output and to energize the wire feed motor.

FEEDING WIRE ELECTRODE

WARNING

When triggering, the electrode and drive mechanism are electrically "hot" relative to work and ground and remain "hot" several seconds after the gun trigger is released.

NOTE: Check that drive rolls, guide plates, and gun parts are proper for the wire size and type being used. Refer to **Table C.1** in **Accessories** section.

1. Turn the Readi-Reel or spool until the free end of the electrode is accessible.
2. While securely holding the electrode, cut off the bent end and straighten the first six inches. (If the electrode is not properly straightened, it may not feed properly through the wire drive system.)
3. Release the pressure on the idle roll by swinging the adjustable pressure arm down toward the back of the machine. Lift the cast idle roll assembly and allow it to sit in an upright position. Leave the outer wire guide plate installed. Manually feed the wire through the incoming guide bushing and through the guide plates (over the drive roll groove). Push a sufficient wire length to assure that the wire has fed into the gun and cable assembly without restriction. Reposition the adjustable pressure arm to its original position to apply pressure to the wire.
4. Press gun trigger to feed the electrode wire through the gun.

IDLE ROLL PRESSURE SETTING

WARNING

ELECTRIC SHOCK can kill.



- Turn the input power OFF at the welding power source before installation or changing drive rolls and/or guides.
- Do not touch electrically live parts.
- When inching with the gun trigger, electrode and drive mechanism are "hot" to work and ground and could remain energized several seconds after the gun trigger is released.
- Only qualified personnel should perform maintenance work.

The pressure arm controls the amount of force the drive rolls exert on the wire. Proper adjustment of both pressure arm gives the best welding performance. For best results, set both pressure arms to the same value.

Set the pressure arm as follows (See Figure B.3):

Aluminum wires	between 1 and 3
Cored wires	between 3 and 4
Steel, Stainless wires	between 4 and 6

FIGURE B.3

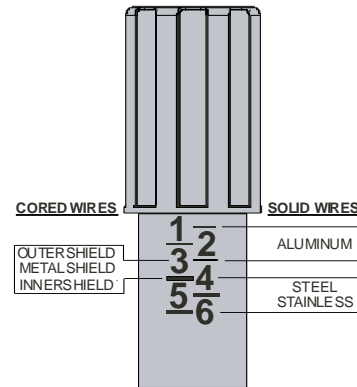

WIRE DRIVE CONFIGURATION

(See Figure B.4)

Changing the Gun Receiver Bushing

ELECTRIC SHOCK can kill.

- Turn the input power OFF at the welding power source before installation or changing drive rolls and/or guides.
- Do not touch electrically live parts.
- When inching with the gun trigger, electrode and drive mechanism are "hot" to work and ground and could remain energized several seconds after the gun trigger is released.
- Only qualified personnel should perform maintenance work.

Tools required:

- 1/4" hex key wrench.

Note: Some gun bushings do not require the use of the thumb screw.

1. Turn power off at the welding power source.
2. Remove the welding wire from the wire drive.
3. Remove the thumb screw from the wire drive.
4. Remove the welding gun from the wire drive.

POWER MIG 255C



5. Loosen the socket head cap screw that holds the connector bar against the gun bushing.
Important: Do not attempt to completely remove the socket head cap screw.
6. Remove the outer wire guide, and push the gun bushing out of the wire drive. Because of the precision fit, light tapping may be required to remove the gun bushing.
7. Disconnect the shielding gas hose from the gun bushing, if required.
8. Connect the shielding gas hose to the new gun bushing, if required.
9. Rotate the gun bushing until the thumb screw hole aligns with the thumb screw hole in the feed plate. Slide the gun receiver bushing into the wire drive and verify the thumb screw holes are aligned.
10. Tighten the socket head cap screw.
11. Insert the welding gun into the gun bushing and tighten the thumb screw.

FIGURE B.4

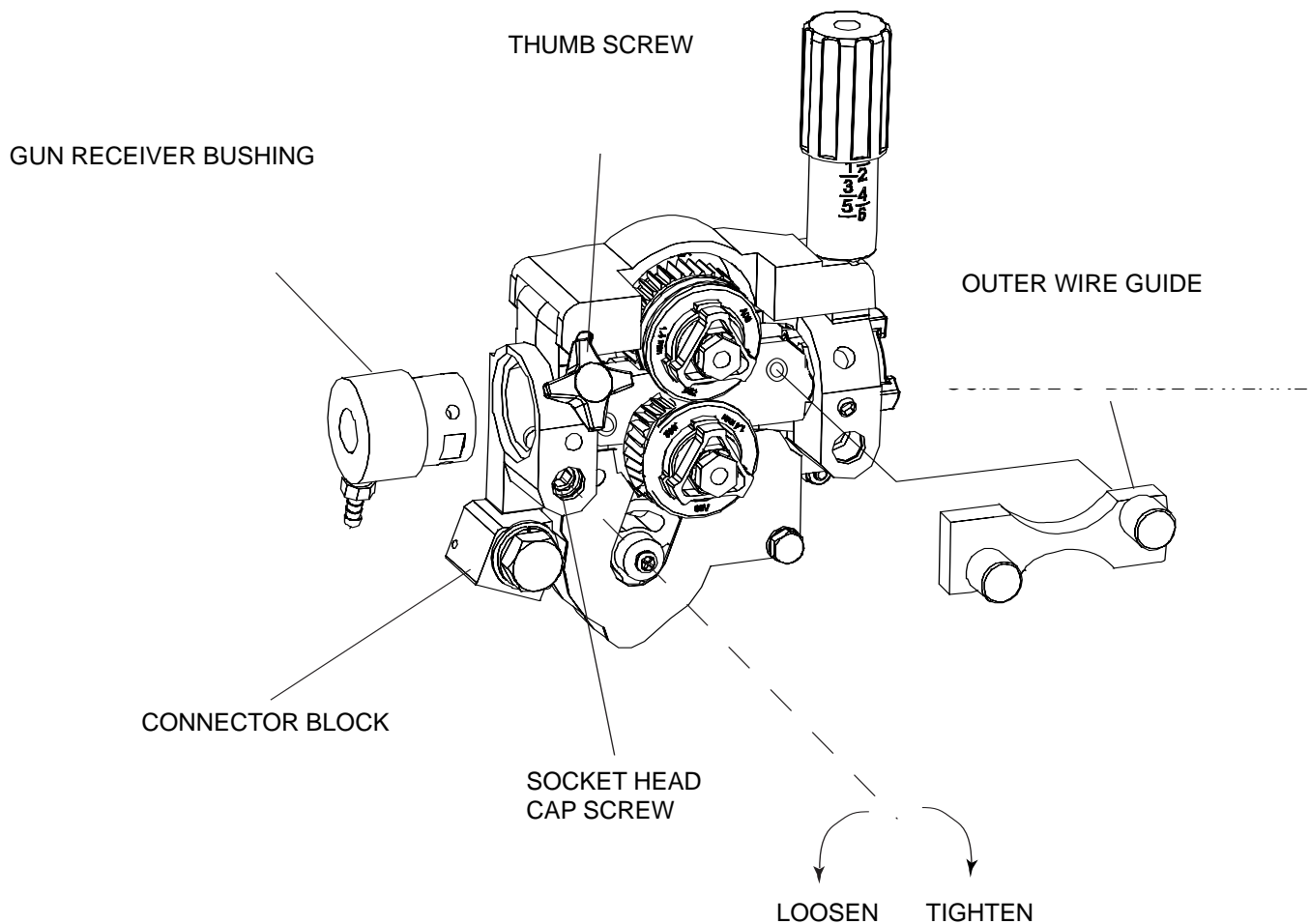

POWER MIG 255C

SETTING RUN-IN SPEED ON STANDARD POWER MIG FEEDER

FAST OR SLOW RUN-IN MODE SELECTION, (When Timer Option is not installed)

The POWER MIG 255C is factory set for fast run-in mode where the wire feed will accelerate directly to the preset wire feed speed when the gun trigger is closed.

Slow run-in mode may also be selected, where it will initially feed wire at 50 IPM until output current is sensed or for 1.0 seconds, whichever occurs first. After which it will accelerate to the preset wire feed speed.

Note: See operating instructions for Timer Option Kit if it is installed, as it provides its own Run-in operation.

INSTRUCTIONS TO ENTER SLOW RUN-IN

1. Turn power OFF on front panel of POWER MIG 255C.
2. Turn the wire feed speed dial to minimum, fully counterclockwise.
3. With the gun trigger closed, turn the power ON at the front panel of the POWER MIG 255C.
4. The display will read "SLO run".

INSTRUCTIONS TO ENTER FAST RUN-IN

1. Turn power OFF on front panel of POWER MIG 255C.
2. Turn the wire feed speed dial to maximum, fully clockwise.
3. With the gun trigger closed, turn the power ON at the front panel of the POWER MIG 255C.
4. The display will read "FAS run".

NOTE: Arc starting characteristics may be effected when using the fast run-in mode since optimum starting processes are being overridden.

On the initial trigger closure at power up, no output power or wire feed will be available until the trigger is opened and reclosed, regardless of wire feed speed dial setting.

It is not necessary to repeat either of the above procedures each time the unit is powered up. The unit will remember the run-in mode from the previous

power down and return you to that same state upon your next power up. Thus, you need only perform one of the above procedures when you want to change the run-in mode.

MAKING A WELD

1. Check that the electrode polarity is correct for the process being used, then turn the power switch ON.
2. Set desired arc voltage and wire speed for the particular electrode wire, material type and thickness, and gas (for GMAW) being used. Use the Application Chart on the door inside the wire compartment as a quick reference for some common welding procedures.
3. If Timer Kit is installed, select the desired mode as described in "Operating Instructions for Timer Kit" in the Accessories section. Refer to the **Accessories** section for additional welding information pertaining to Spot mode. That chart is also in this manual as **Figure B.5**.
4. Press the trigger to feed the wire electrode through the gun and cable and then cut the electrode within approximately 3/8" (10 mm) of the end of the contact tip [3/4" (20 mm) Outershield®].

NOTE: If set for slow run-in when the trigger is pulled, the wire feeder feeds wire at low speed regardless of the set wire feed speed until the welding arc starts or 1 second has elapsed. This feature enhances starting and makes it easier to set the stickout. The 1 second limit permits high speed loading of the gun and cable. To change run-in mode, see "Setting Run-In Speed" in this section, if the Timer Kit is not installed, or Timer Kit Operation section if installed.

5. If welding gas is to be used, turn on the gas supply and set the required flow rate (typically 25-35 CFH; 12-16 liters/min).
6. When using Innershield electrode, the gas nozzle may be removed from the insulation on the end of the gun and replaced with the gasless nozzle. This will give improved visibility and eliminate the possibility of the gas nozzle overheating.
7. Connect work cable to metal to be welded. Work clamp must make good electrical contact to the work. The work must also be grounded as stated in "Arc Welding Safety Precautions".

POWER MIG 255C



⚠ WARNING

When using an open arc process, it is necessary to use correct eye, head, and body protection.

8. Position electrode over joint. End of electrode may be lightly touching the work.
9. Lower welding helmet, close gun trigger, and begin welding. Hold the gun so the contact tip to work distance is about 3/8" (10 mm) [3/4" (20 mm) for Outershield].
10. To stop welding, release the gun trigger and then pull the gun away from the work after the arc goes out.
11. When no more welding is to be done, close valve on gas cylinder (if used), momentarily operate gun trigger to release gas pressure, and turn off POWER MIG 255C.

AVOIDING WIRE FEEDING PROBLEMS

Wire feeding problems can be avoided by observing the following gun handling procedures:

- a. Do not kink or pull cable around sharp corners.
- b. Keep the gun cable as straight as possible when welding or loading electrode through cable.
- c. Do not allow dolly wheels or trucks to run over cables.
- d. Keep cable clean by following maintenance instructions.
- e. Use only clean, rust-free electrode. The Lincoln electrodes have proper surface lubrication.
- f. Replace contact tip when the arc starts to become unstable or the contact tip end is fused or deformed.

- g. Keep wire reel spindle brake tension to minimum required to prevent excess reel over-travel which may cause wire "loop-offs" from coil.
- h. Use proper drive rolls and wire drive idle roll pressure for wire size and type being used.

FAN CONTROL

The fan is designed to come on automatically when a weld arc is established. The fan will stay on for a minimum of 6 minutes after the weld arc is terminated. The fan will also stay on when the machine's welding and feeding are disabled during thermostatic over temperature protection. (See *Welding Thermal Overload Protection*)

INPUT LINE VOLTAGE PROTECTION

High Line Voltage — If the line voltage exceeds 125% of rated input voltage, the output will be reduced to the lower level to protect voltage rating of the capacitor bank.

Low Line Voltage — You may not be able to get maximum output from the machine if the line voltage is less than rated input. The unit will continue to weld, but the output may be less than what is set.

WIRE FEED OVERLOAD PROTECTION

The POWER MIG 255C has solid state overload protection of the wire drive motor. If the motor becomes overloaded, the protection circuitry turns off the wire feed speed weld output and gas solenoid. Check for proper size tip, liner, and drive rolls, for any obstructions or bends in the gun cable, and any other factors that would impede the wire feeding.

To resume welding, simply pull the trigger. There is no circuit breaker to reset, as the protection is done with reliable solid state electronics.

TABLE OF CONTENTS
-ACCESSORIES SECTION-

Accessories	Section C
Drive Roll Kits	C-2
3/64 in. (1.2 mm) Aluminum Feeding Kit (K1703-1)	C-2
K363P Readi-Reel Adapter	C-2
Dual Cylinder Mounting Kit (K1702-1)	C-2
Alternative Magnum GMAW Gun and Cable Assemblies	C-2
Magnum Gun Connection Kit (Optional K466-6)	C-2
Timer Kit Installation (Optional K1701-1)	C-2
Operating Instructions for Timer Kit	C-3
Connecting Spool Gun Adapter Kit	C-3
Making a Weld with the Spool Gun	C-4

Return to Master TOC

Return to Master TOC

Return to Master TOC

Return to Master TOC

DRIVE ROLL KITS

Refer to Table C.1 for various drive roll kits that are available for the POWER MIG. All items in **Bold** are supplied standard with the POWER MIG.

TABLE C.1 — AVAILABLE DRIVE ROLL KITS.

Electrode Type	Wire Size	Drive Roll Kit
Solid Steel (Includes Stainless Steel)	.023"-.030" (0.6-0.8 mm)	KP1696-030S
	.035" (0.9 mm)	KP1696-035S
	.045" (1.2 mm)	KP1696-045S
	.035-.045 (0.9-1.2mm)	KP1696-1
	.040 (1.01)	KP1696-2
Cored	.035" (0.9 mm)	KP1697-035C
	.045" (1.2 mm)	KP1697-045C
Aluminum	3/64" (1.2 mm)	KP1695-3/64A

3/64" (1.2 mm) ALUMINUM FEEDING KIT (K1703-1)

This kit helps push feeding aluminum through standard machine feeder and gun. It provides gun and wire drive conversion parts to weld with 3/64" (1.2 mm) aluminum wire. 5356 alloy aluminum wire is recommended for best push feeding performance.

Kit includes drive rolls and wire guide plate for the wire drive, liner and two contact tips for the gun, along with installation instructions.

K2378-1 Canvas Cover

K468 Spindle Adapter - for 8" (203.2mm) O.D. spool.

K363P READI-REEL ADAPTER

The K363P Readi-Reel Adapter mounts to the 2" spindle. It is needed to mount the 22-30 lb. Readi-Reels.

DUAL CYLINDER MOUNTING KIT (K1702-1)

Permits stable side-by-side mounting of two full size (9" dia. x 5' high) gas cylinders with "no lift" loading. Simple installation and easy instructions provided. Includes upper and lower cylinder supports, wheel axles and mounting hardware.

ALTERNATIVE MAGNUM GMAW GUN AND CABLE ASSEMBLIES

The following Magnum 250L gun and cable assemblies are separately available for use with the POWER MIG 255C. Each is rated 200 amps 60% duty cycle (or 250 amps 40% duty) and is equipped with the integrated connector, twist-lock trigger connector, fixed nozzle and insulator, and includes a liner, diffuser, and contact tips for the wire sizes specified:

Length	Part No.	English Wire Size ¹	Metric Wire Size
12' (3.6 m)	K533-7	.035 - .045"	0.9 - 1.2 mm
15' (4.5 m)	K533-3		

MAGNUM GUN CONNECTION KIT (Optional K466-6)

Using the optional K466-6 Magnum Connection kit for the POWER MIG permits use of standard Magnum 200, 300 or 400 gun and cable assemblies.

TIMER KIT INSTALLATION (Optional K1701-1)

The timer kit adds selectable 4-step trigger interlock, spot and Run-In functions and manual adjustment of burnback time. Install as follows, or per the instructions included with the kit:

WARNING

Remove all input power to the POWER MIG 255C before proceeding.

- Verify that the following items have been included in the kit:
 - Timer board/with harness and panel assembly .
 - Two screws.
- Prepare for kit installation by turning the power switch off and disconnecting power from the machine.
- Remove the lower cover panel from the front of the machine by removing the two screws which secure
- Attach the black rectangular 10-pin plug connector on the timer kit wiring harness to the black mating receptacle connector located on the P.C. board. Be sure that the latch on the connector is aligned with the one on the board and insert it until the latch engages.
- Align the timer panel for installation and carefully insert the printed circuit board and wiring harness through the opening. Make sure the wiring harness is not pinched between panels or between printed circuit board and front panel cover.
- Secure the timer assembly with either the two supplied screws or with the original screws. The installation is now complete. Refer to the following section for operating instructions.

POWER MIG 255C



OPERATING INSTRUCTIONS FOR TIMER KIT

If the optional Timer Kit (K1701-1) is installed, select the desired mode with the selector switch:

- A. **Normal Welding mode** provides weld power only while the trigger switch is depressed. This is the same operation as when the Timer Kit is not installed.
- B. **4-Step Trigger interlock mode** eliminates the need to hold the gun trigger while welding. It operates in 4 steps:
1. Close trigger and establish welding arc.
 2. Release trigger and continue welding.
 3. Reclose trigger near end of weld.
 4. Release trigger again to stop welding.

If the arc is broken while using this feature, the machine will reset to the "trigger off" condition automatically.

Note: 4 Step Trigger interlock mode does not function with a Spool Gun.

- C. **Spot Weld Mode** is used for tack welding parts into position or for spot plug welds to hold thin sheet metal together prior to manual stitch or continuous welding. To use this feature, adjust the On-Time (0-5 seconds) as appropriate to obtain the desired results. Closing the trigger initiates a single timed spot weld cycle.

Plug welds are made by using a punch to make a 3/16" (5 mm) diameter hole in the top sheet and arc welding through the hole into the back sheet.

To make spot plug welds, punch 3/16" (5 mm) holes in the top sheet. Set the Spot Time control to approximately 1.2 seconds and set the procedure for the metal thickness to be welded. Install spot weld nozzle (if available) on gun and press it against the top sheet so the top and bottom sheets are tight together. Close trigger and hold it closed until the arc goes out. If a spot weld nozzle is not used, smoother welds will result by moving the welding wire in a small circle during the weld.

- D. **Burnback Time** control provides manual adjustment of the burnback time (0-250 milliseconds) for any selected welding mode. This control should be set as low as possible without the wire "sticking" in the puddle after each weld. Too long of a burnback time may form a "ball" on the end of the wire, or may "flash back" to the gun tip.

- E. **Run-In Mode** is used to adjust the starting wire feed speed. Starting conditions for certain welding applications can be improved with adjustment to the Run-In speed. The control allows for initial starting speeds from 50 - 150 IPM. After the arc is started, the set point on the wire feed speed control will dominate. Note that the Run-in is not functional with the spool gun. Also note that if Run-in is set fully counter clockwise to "OFF", Run-in speed will equal the preset WFS on the machine.

SPOOL GUN

Remove all input power to the POWER MIG 255C before proceeding.

⚠ WARNING

The POWER MIG 255C provides direct connection and use of the Spool Gun (with remote speed control).

It also provides gun trigger switch transfer between the machine's use with its feeder gun or the spool gun for same polarity welding with different wire and gas processes.

K2297-2	Prince® XL Spool Gun
K487-25	Magnum® SG Spool Gun (requires K2445-1 Cable Adapter)

K2445-1 Magnum SG Spool gun Control Cable Adapter

Allows the K487-25 Magnum SG spool gun's 6-pin control cable plug to connect to the Power MIG 255C's 7-pin spool gun control cable receptacle.

K1738-1 Spool Gun Hanger Accessory

CONNECTING THE SPOOL GUN TO THE POWER MIG 255C

(See Figure C.1)

1. Connect the Spool Gun control cable to the mating 7-pin receptacle in the Power MIG wire drive compartment. K487-25 Magnum SG Spool Gun requires K2445-1 cable 7-pin to 6-pin adapter.
2. Connect the Spool Gun electrode lead to the (+)positive stud with the Spool Gun electrode lead sandwiched between the (+)positive power source electrode lead and the (+)positive stud. Tighten and be careful not to strip the threads.
3. Attach the Spool Gun gas line to the 5/8 Gas fitting on the front of the machine.
4. Attach a Gas hose from the Gas supply to the rear inlet gas fitting on the Power MIG 255C.

POWER MIG 255C



FIGURE C.1

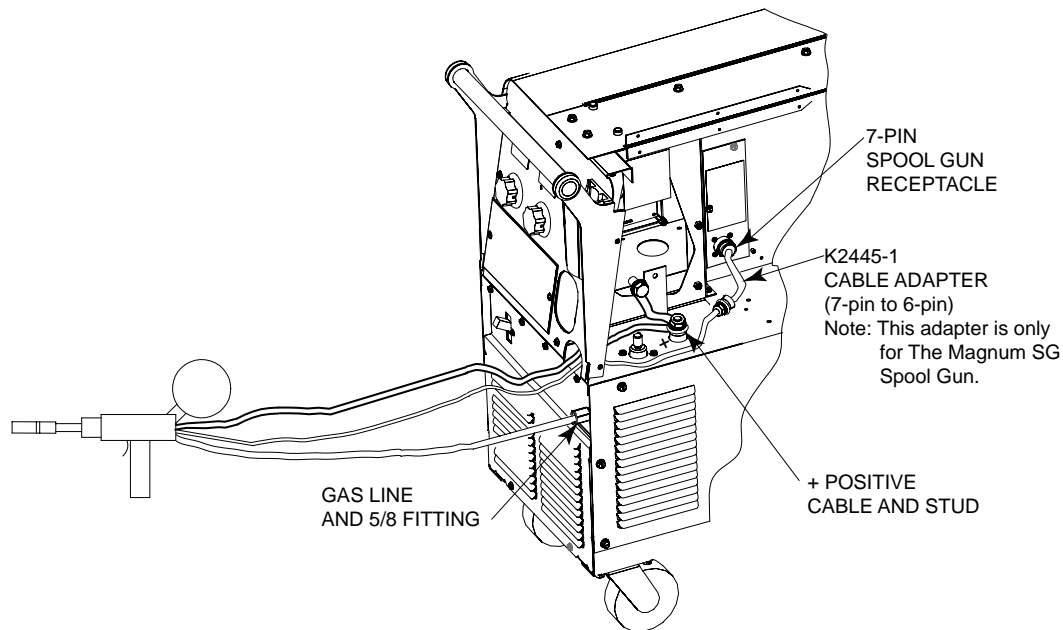

MAKING A WELD WITH THE PRINCE XL SPOOL GUN

The POWER MIG control circuitry is designed to sense either the spool gun or (built in) wire feeder trigger circuitry. The spool gun can easily be plugged in and will be ready to use.

CAUTION

Closing either gun trigger will cause the electrode of both guns to be electrically "HOT". Be sure unused gun is positioned so electrode or tip will not contact metal case or other metal common to work.

1. Pulling the trigger for the built-in feeder gun:
 - a. Disables spool gun operation.
 - b. Closing feeder gun trigger starts feeder gun welding and makes both electrodes electrically "HOT".
2. Pulling SPOOL GUN Trigger:
 - a. Disables built-in feeder gun operation.
 - b. Closing spool gun trigger starts spool gun welding and makes both electrodes electrically "HOT".
3. Operation with POWER MIG 255C:
 - a. Turn the POWER MIG 255C input power ON.
 - b. Adjusting the voltage control will increase or decrease your welding voltage.

- c. Adjusting the wire speed control on the spool gun will increase or decrease the spool gun wire feed speed.
 - d. To aid in set-up, the POWER MIG 255C wire feed speed(WFS) meter will display the approximate WFS of the gun. Actual WFS at the gun may vary from the displayed value due to tension setting, liner condition or gun variation.
4. The following procedure settings for Aluminum 4043 can be used as initial settings for making test welds to determine final settings:

Wire Diameter In. (mm)	Wire Feed Speed Display	Arc voltage Setting
.030" (.8mm)	270	15V
.035" (.9mm)	250	16V
3/64" (1.2mm)	240	20V

5. To return to normal POWER MIG 255C welding, release the spool gun trigger and reset feeder gun voltage procedure setting if necessary.

MAKING A WELD WITH THE MAGNUM SG SPOOL GUN

The POWER MIG control circuitry is designed to sense either the spool gun or (built in) wire feeder trigger circuitry. The spool gun can easily be plugged in and will be ready to use.

POWER MIG 255C



⚠ CAUTION

Closing either gun trigger will cause the electrode of both guns to be electrically "HOT". Be sure unused gun is positioned so electrode or tip will not contact metal case or other metal common to work.

1. Pulling the trigger for the built-in feeder gun:
 - a. Disables spool gun operation.
 - b. Closing feeder gun trigger starts feeder gun welding and makes both electrodes electrically "HOT".
2. Pulling SPOOL GUN Trigger:
 - a. Disables built-in feeder gun operation.
 - b. Closing spool gun trigger starts spool gun weld-ing and makes both electrodes electrically "HOT".
3. Operation with POWER MIG 255C:
 - a. Turn the POWER MIG 255C input power ON.
 - b. Adjusting the voltage control will increase or decrease your welding voltage.
 - c. Adjusting the wire speed control on the spool gun will increase or decrease the spool gun wire feed speed.
 - d. For the Magnum SG Spool Gun, the wire feed speed is controlled by combination of the wire feed speed displayed on the POWER MIG 255C and the wire speed control on the spool gun.

See the following procedure for setting the Wire Speed Feed using the Magnum SG Spool Gun:

Wire Feed Speed Display	SG Spool Gun Wire Feed Speed Approximate Range
50	50-200
300	200-400
700	300-600

To determine spool gun wire feed speed use a hand tachometer, or calculate the speed using the following equation:

$$\text{IPM} = \text{Length of wire fed (inches)} \times 60$$

$$\text{Time fed (seconds)}$$

4. To return to normal POWER MIG 255C welding, release the spool gun trigger and reset feeder gun welding procedures.

POWER MIG 255C



Return to Section TOC
Return to Master TOC
Return to Section TOC
Return to Master TOC
Return to Section TOC
Return to Master TOC
Return to Section TOC
Return to Master TOC
Return to Section TOC
Return to Master TOC

POWER MIG 255



TABLE OF CONTENTS
-MAINTENANCE SECTION-

Maintenance	Section D
Safety Precautions	D-2
General Maintenance	D-2
Drive Rolls and Guide Plates	D-2
Contact Tip & Gas Nozzle Installation	D-2
Gun Tubes and Nozzles	D-2
Gun Cable Cleaning	D-2
Liner Removal and Replacement	D-2
Liner Removal, Installation, and Trimming Instructions for Magnum 250L	D-3
Accessories and Expendable Replacement Parts for Magnum 250L Gun and Cable Assemblies .	D-4

Return to Master TOC

Return to Master TOC

Return to Master TOC

Return to Master TOC

SAFETY PRECAUTIONS

⚠ WARNING



- Have a qualified electrician do the maintenance and troubleshooting work.
 - Disconnect the input power off using the disconnect switch at the main input supply before working inside machine.
- Unplug the power cable if it is connected to a receptacle.

GENERAL MAINTENANCE

In extremely dusty locations, dirt may clog the air passages causing the welder to run hot. Blow dirt out of the welder with low-pressure air at regular intervals to eliminate excessive dirt and dust build-up on internal parts.

The fan motors have sealed ball bearings which require no service.

DRIVE ROLLS AND GUIDE PLATES

After every coil of wire, inspect the wire drive mechanism. Clean it as necessary by blowing with low pressure compressed air. Do not use solvents for cleaning the idle roll because it may wash the lubricant out of the bearing.

All drive rolls are stamped with the wire sizes they will feed. If a wire size other than that stamped on the roll is used, the drive roll must be changed.

For instructions on replacing or changing drive roll, see "Wire Drive Rolls" in Operation section.

CONTACT TIP AND GAS NOZZLE INSTALLATION

- Choose the correct size contact tip for the electrode being used (wire size is stenciled on the side of the contact tip) and screw it snugly into the gas diffuser.
- Screw the appropriate fixed gas nozzle fully onto the diffuser. Either the standard .50" (12.7 mm) flush nozzle or other optional flush or recessed (spray arc) nozzle sizes may be used. (See **Table D.2** in this section.)
- If using optional adjustable slip-on nozzles, see **Table D.2** in this section.

1. Be sure the nozzle insulator is fully screwed onto the gun tube and does not block the gas holes in the diffuser.

2. Slip the appropriate gas nozzle onto the nozzle insulator. Either a standard .50" (12.7 mm) or optional .62" (15.9 mm) I.D. slip-on gas nozzle may be used and should be selected based on the welding application.

Adjust the gas nozzle as appropriate for the GMAW process to be used. Typically, the contact tip end should be flush to .12" (3.2 mm) extended for the short-circuiting transfer process and .12" (3.2 mm) recessed for spray transfer.

GUN TUBES AND NOZZLES

- a. Replace worn contact tips as required.
- b. Remove spatter from inside of gas nozzle and from tip after each 10 minutes of arc time or as required.

GUN CABLE CLEANING

To help prevent feeding problems, clean cable liner after using approximately 300 pounds (136 kg) of electrode. Remove the cable from the wire feeder and lay it out straight on the floor. Remove the contact tip from the gun. Using an air hose and only partial pressure, gently blow out the cable liner from the gas diffuser end.

⚠ CAUTION

Excessive pressure at the start may cause the dirt to form a plug.

Flex the cable over its entire length and again blow out the cable. Repeat this procedure until no further dirt comes out. If this has been done and feed problems are experienced, try liner replacement, and refer to trouble shooting section on rough wire feeding.

LINER REMOVAL AND REPLACEMENT

NOTE: Changing the liner for a **different** wire size requires replacement of the gas diffuser per **Table D.1** to properly secure the different liner.

TABLE D.1

Diameter of Electrode Used	Replace ment Line Part Number	Size Stencilled on End of liner Bushing	Fixed Nozzle Gas Diffuser Part No. (and stencil)	Adjustable nozzle Gas Diffuser Part No. (and Stencil)
.025-.030" Steel (0.6-0.8 mm)	KP1934-2	.030 (0.8 mm)	KP2026-3	KP2026-2
.035-.045" Steel (0.9-1.2 mm)	KP1934-1	.045 (1.2 mm)	KP2026-3	KP2026-1B1
3/64" Aluminum (1.2 mm)	KP1955-1	3/64" (1.2 mm)	KP2026-3	KP2026-1B1

LINER REMOVAL, INSTALLATION AND TRIMMING INSTRUCTIONS FOR MAGNUM 250L

NOTE: The variation in cable lengths prevents the interchangeability of liners between guns. Once a liner has been cut for a particular gun, it should not be installed in another gun unless it can meet the liner cutoff length requirement. Liners are shipped with the jacket of the liner extended the proper amount.

1. Remove the gas nozzle and nozzle insulator, if used, to locate the set screw in the gas diffuser which is used to hold the old liner in place. Loosen the set screw with a 5/64" (2.0 mm) Allen wrench.
2. Remove the gas diffuser from the gun tube.
3. Lay the gun and cable out straight on a flat surface. Loosen the set screw located in the brass connector at the feeder end of the cable and pull the liner out of the cable.
4. Insert a new untrimmed liner into the connector end of the cable. Be sure the liner bushing is stencilled appropriately for the wire size being used.

Note: For liners KP1950-7, KP1950-8, KP1955-1 and KP1599-2

Before fully seating the liner bushing, it will be necessary to trim the liner's inner tube flush with the liner bushing using a sharp blade. After trimming, remove any burrs from inner tube and insure that the opening is fully open.

5. Fully seat the liner bushing into the connector. tighten the set screw on the brass cable connector. The gas diffuser, at this time, should not be installed onto the end of the gun tube.

6. With the gas diffuser still removed from the gun tube, be sure the cable is straight, and then trim the liner to the length shown in Figure D.1. Remove any burrs from the end of the liner.
7. Screw the gas diffuser onto the end of the gun tube and securely tighten. Be sure the gas diffuser is correct for the liner being used. (See table and diffuser stencil.)
8. Tighten the set screw in the side of the gas diffuser against the cable liner using a 5/64" (2.0 mm) Allen wrench.

FIGURE D.1

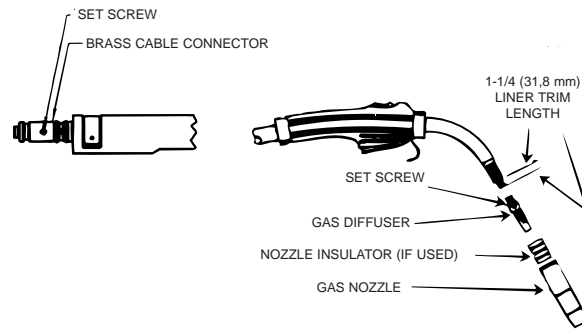

⚠ WARNING

This screw should only be gently tightened. Overtightening will split or collapse the liner and cause poor wire feeding.

GUN HANDLE DISASSEMBLY

The internal parts of the gun handle may be inspected or serviced if necessary.

The gun handle consists of two halves that are held together with a collar on each end. To open up the handle, turn the collars approximately 60 degrees counterclockwise (the same direction as removing a right hand thread) until the collar reaches a stop. Then pull the collar off the gun handle. If the collars are difficult to turn, position the gun handle against a corner, place a screwdriver against the tab on the collar and give the screwdriver a sharp blow to turn the collar past an internal locking rib.

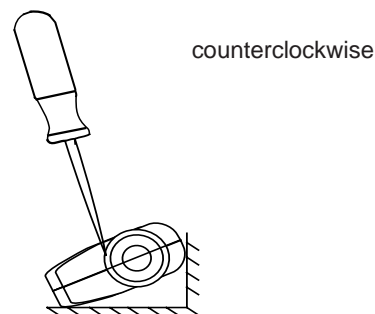

POWER MIG 255C

LINCOLN
ELECTRIC

**TABLE D.2
ACCESSORIES AND EXPENDABLE REPLACE-
MENT PARTS FOR MAGNUM 250L GUN AND
CABLE ASSEMBLIES**

Description	Part No.	English Size	Metric Size	
CABLE LINER For 15' (4.5 m) or shorter cable	KP1934-2	.025 – .030"	0.6 – 0.8 mm	
	KP1934-1	.035 – .045"	0.9 – 1.2 mm	
	KP1955-1	3/64" (Alum. wire)	1.2 mm (Alum. wire)	
CONTACTS TIPS Standard Duty	KP2020-6B1	.025"	0.6 mm	
	KP2020-7B1	.030"	0.8 mm	
	KP2020-1B1*	.035"	0.9 mm	
	KP2020-2B1*	.045"	1.2 mm	
	Heavy Duty	KP2021-1B1	.035"	0.9 mm
		KP2021-2B1	.045"	1.2 mm
	Tapered	KP2021-5B1	.025"	0.6 mm
		KP2021-6B1	.030"	0.8 mm
		KP2022-1B1	.035"	0.9 mm
	Notched (For Alum.)	KP2022-2B1	.045"	1.2 mm
KP2010-5B1		3/64" (Alum. Wire)	1.2 mm (Alum. Wire.)	
GAS NOZZLES Fixed (Flush)	KP1931-1	3/8"	9.5 mm	
	KP1931-2*	1/2"	12.7 mm	
	KP1931-3	5/8"	15.9 mm	
	(Recessed)	KP1930-1	3/8"	9.5 mm
		KP1930-2	1/2"	12.7 mm
		KP1930-3	5/8"	15.9 mm
	Requires: Gas Diffuser as'bly	KP2026-3 *	.025 – .045"	0.6 – 1.2 mm
	Adjustable Slip On	KP1935-2	1/2"	12.7 mm
		KP1935-1	5/8"	15.9 mm
	Requires: Nozzle Insulator	KP2025-1		
	Requires: Gas diffuser As'bly	KP2026-2	.025 – .030"	0.6 – 0.8 mm
		KP2026-1	.035 – .045"	0.9 – 1.2 mm
	Gasless nozzle (For Innershield)	KP1947-1Δ		
GUN TUBE ASSEMBLIES Standard (60°) 45°	KP2015-1 *			
	KP2041-1			

*Included with POWER MIG 255C

Δ Requires KP2026-1 Gas Diffuser

POWER MIG 255C



TABLE OF CONTENTS
-THEORY OF OPERATION SECTION-

Theory of Operation	Section E
Input Line Voltage and Main Transformer	E-2
Output Rectification and Feedback Control	E-3
Constant Voltage Output	E-4
Wire Drive Motor and Feedback	E-5
Thermal and Overload Protection	E-6
Overcurrent Protection	E-6
Wire Feed Overload Protection	E-6
SCR Operation	E-7

FIGURE E.1 — BLOCK LOGIC DIAGRAM.

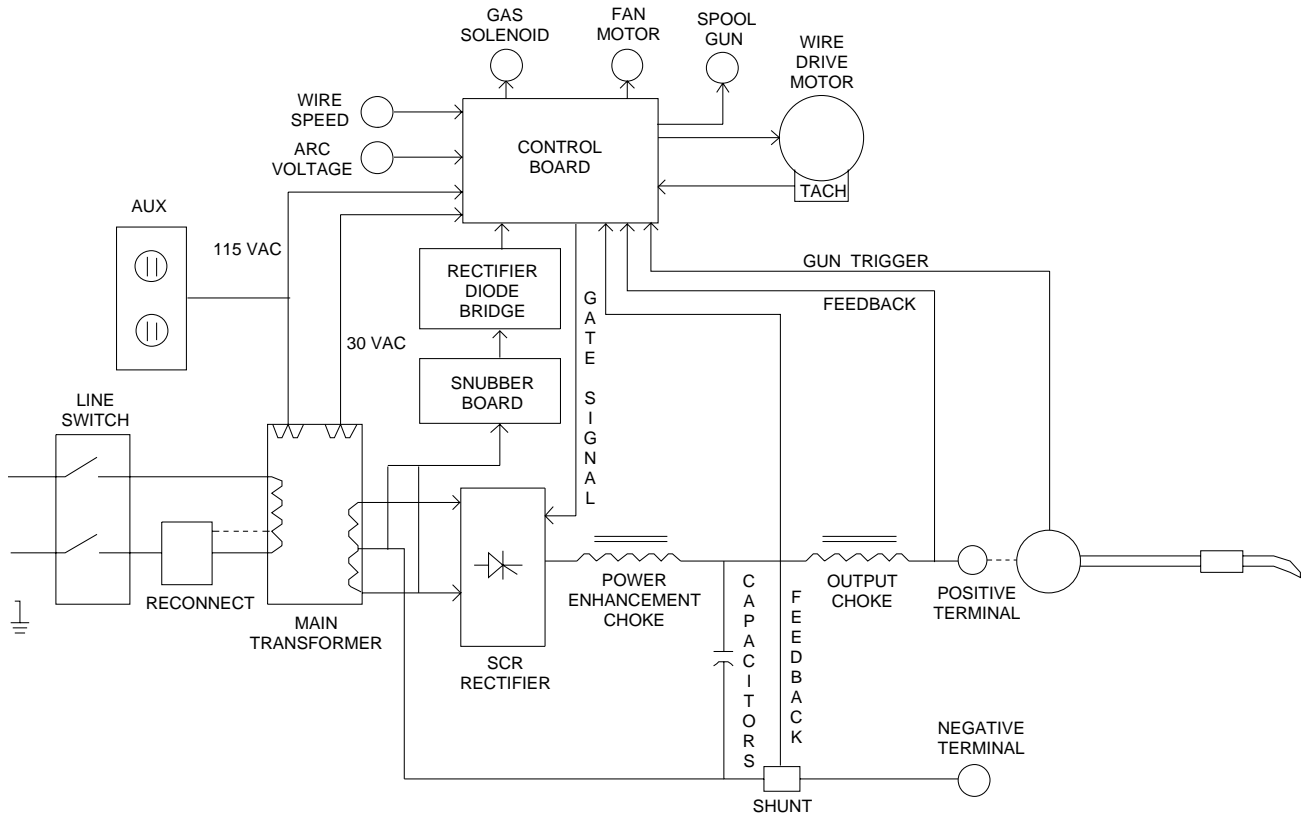

NOTE: Unshaded areas of Block Logic Diagram are the subject of discussion

POWER MIG 255C



Return to Master TOC

Return to Master TOC

Return to Master TOC

Return to Master TOC

FIGURE E.2 — INPUT LINE VOLTAGE AND MAIN TRANSFORMER.

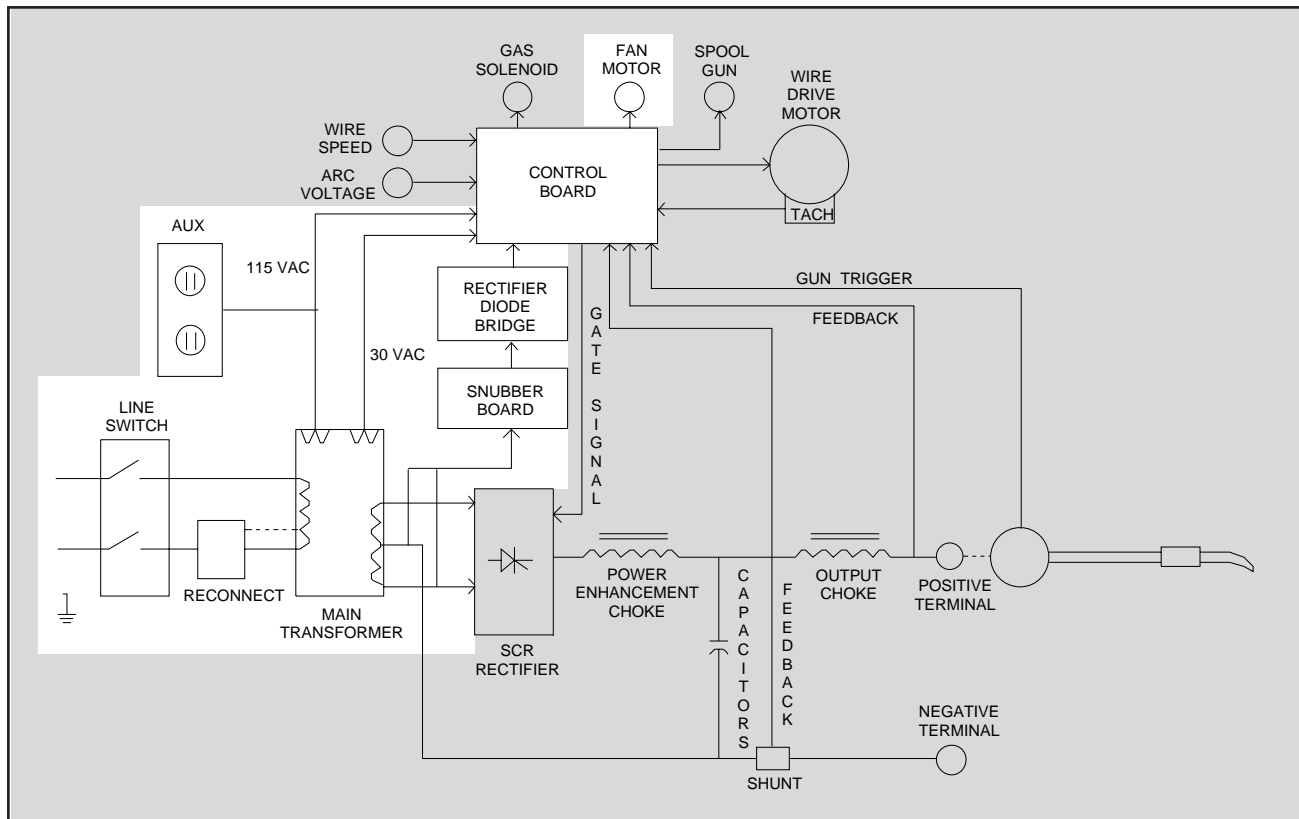

INPUT LINE VOLTAGE AND MAIN TRANSFORMER

The desired single phase input power is connected to the POWER MIG 255C through a line switch located on the front panel.

A reconnect panel allows the user to configure the machine for the desired input voltage. This AC input voltage is applied to the primary of the main transformer. The main transformer converts the high voltage, low current input power to a low voltage, high current output. In addition, the main transformer also has an isolated center tapped 30 VAC auxiliary winding that supplies power to the Control Board for the SCR

gate drive circuitry. The weld power windings connect to the main SCR Rectifier and via the Snubber Board to the Rectifier Diode Bridge. This AC voltage is rectified and then regulated by the control board. The resultant +15 VDC and +5 VDC voltages supply power to the control board circuitry. The 115 VAC winding supplies power, through the control board, to the thermostatically controlled fan motor and also provides voltage for the auxiliary receptacle

The fan is designed to come on automatically when weld arc is established. The fan will stay on for a minimum of six minutes after the weld arc is terminated. The fan will also stay on when the machine's welding and feeding are disabled during thermostatic over-temperature protection. (See **Thermal and Overload Protection**.)

NOTE: Unshaded areas of Block Logic Diagram are the subject of discussion

POWER MIG 255C

LINCOLN
ELECTRIC

FIGURE E.3 — OUTPUT RECTIFICATION AND FEEDBACK.

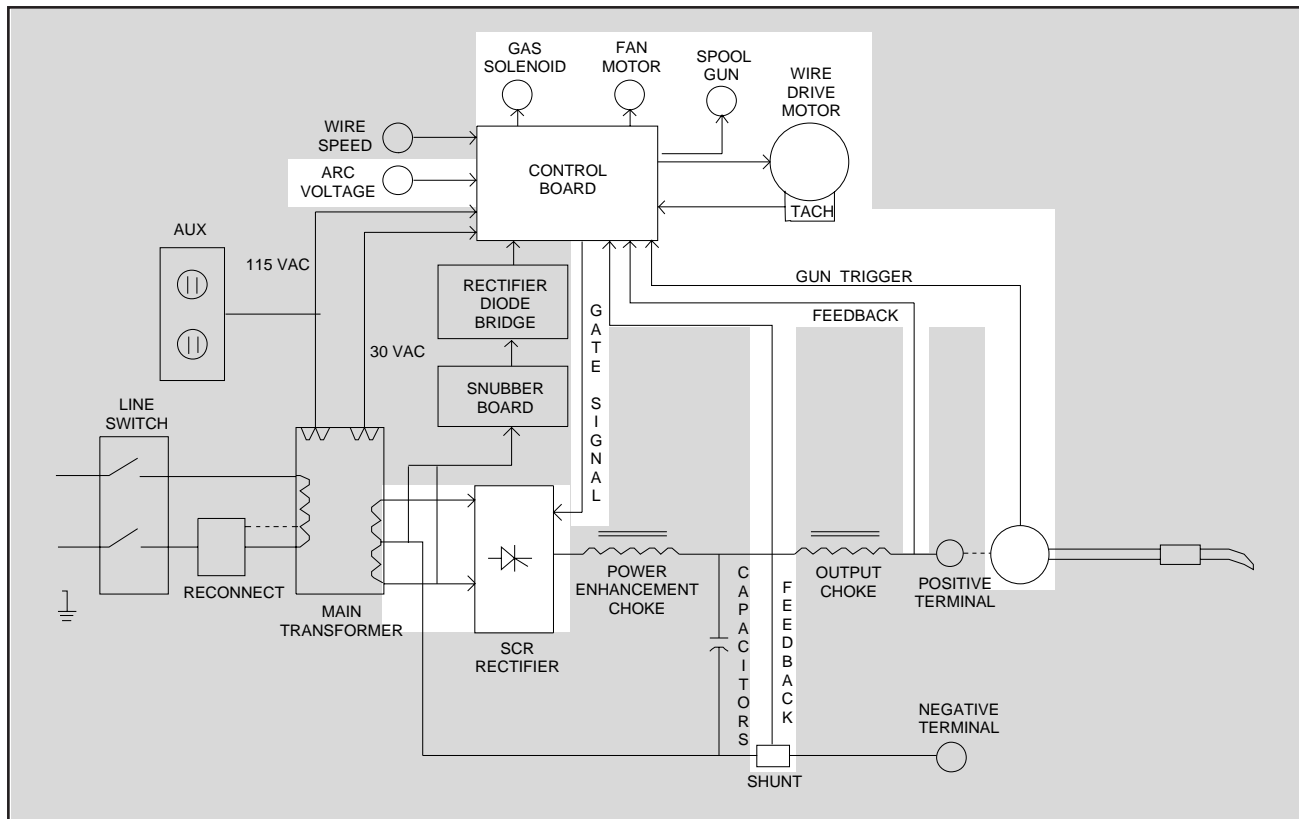

OUTPUT RECTIFICATION AND FEEDBACK CONTROL

The AC output from the main transformer secondary weld winding is rectified and controlled through the SCR rectifier assembly. Output voltage and current are sensed at the shunt and output terminals and are fed back to the control board. The control board compares

the commands of the ARC Voltage Control potentiometer with the feedback signals. The appropriate gate firing pulses are generated by the control board and applied to the SCR rectifier assembly. The control board controls the firing of the SCRs, thus controlling the output of the machine. See **SCR Operation**. The control board also powers and commands the gas solenoid, fan motor, the wire drive motor, and spool gun receptacle.

NOTE: Unshaded areas of Block Logic Diagram are the subject of discussion

POWER MIG 255C

LINCOLN
ELECTRIC

FIGURE E.4 — CONSTANT VOLTAGE OUTPUT.

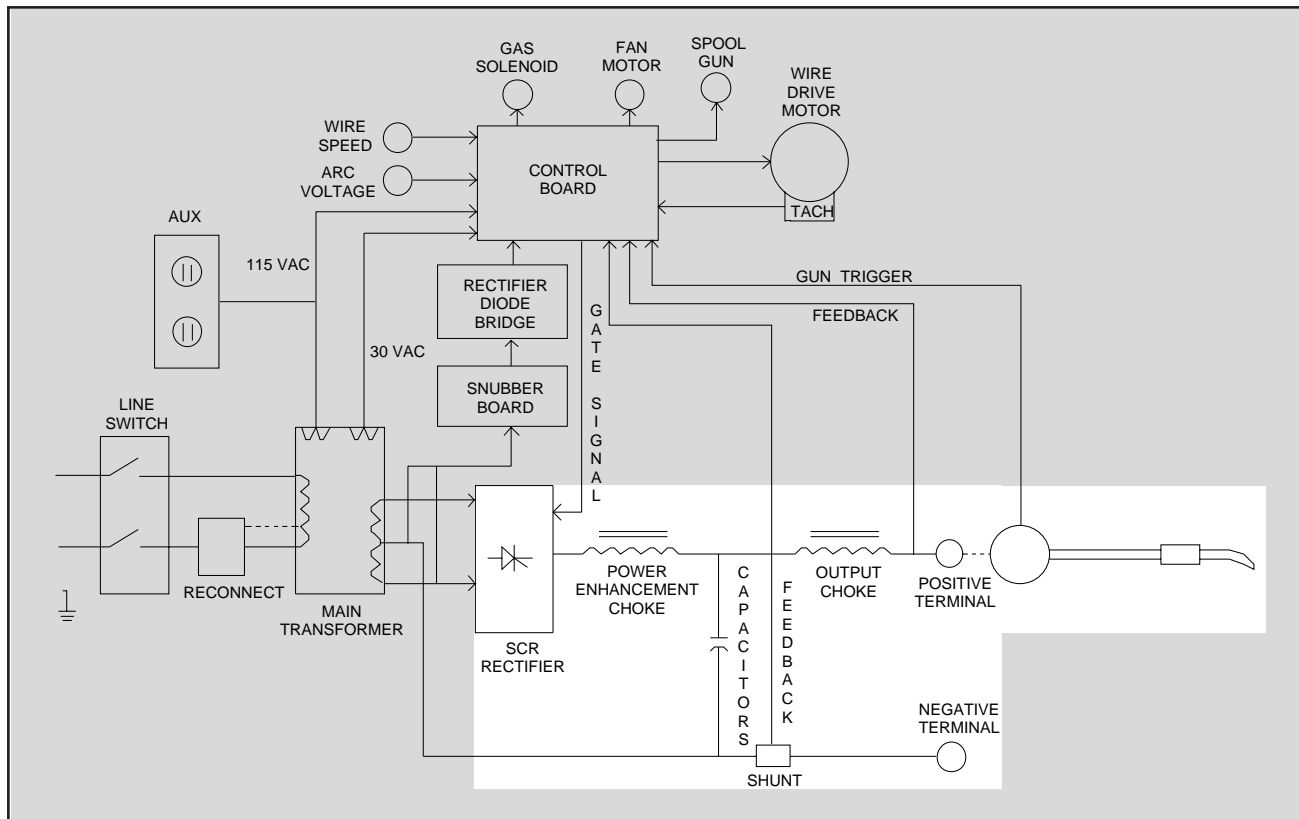

CONSTANT VOLTAGE OUTPUT

The controlled DC output from the SCR rectifier assembly is supplied to the power factor enhancement choke which limits the rate at which the supply current rises through the capacitors. The DC output from the

power factor enhancement choke is filtered by the capacitor bank resulting in a constant voltage DC output. Since the output choke is in series with the positive leg of the rectifier and also in series with the gun and welding load, a filtered constant voltage output is applied to the output terminals of the machine.

NOTE: Unshaded areas of Block Logic Diagram are the subject of discussion

POWER MIG 255C

LINCOLN
ELECTRIC

FIGURE E.5 — WIRE DRIVE MOTOR AND FEEDBACK.

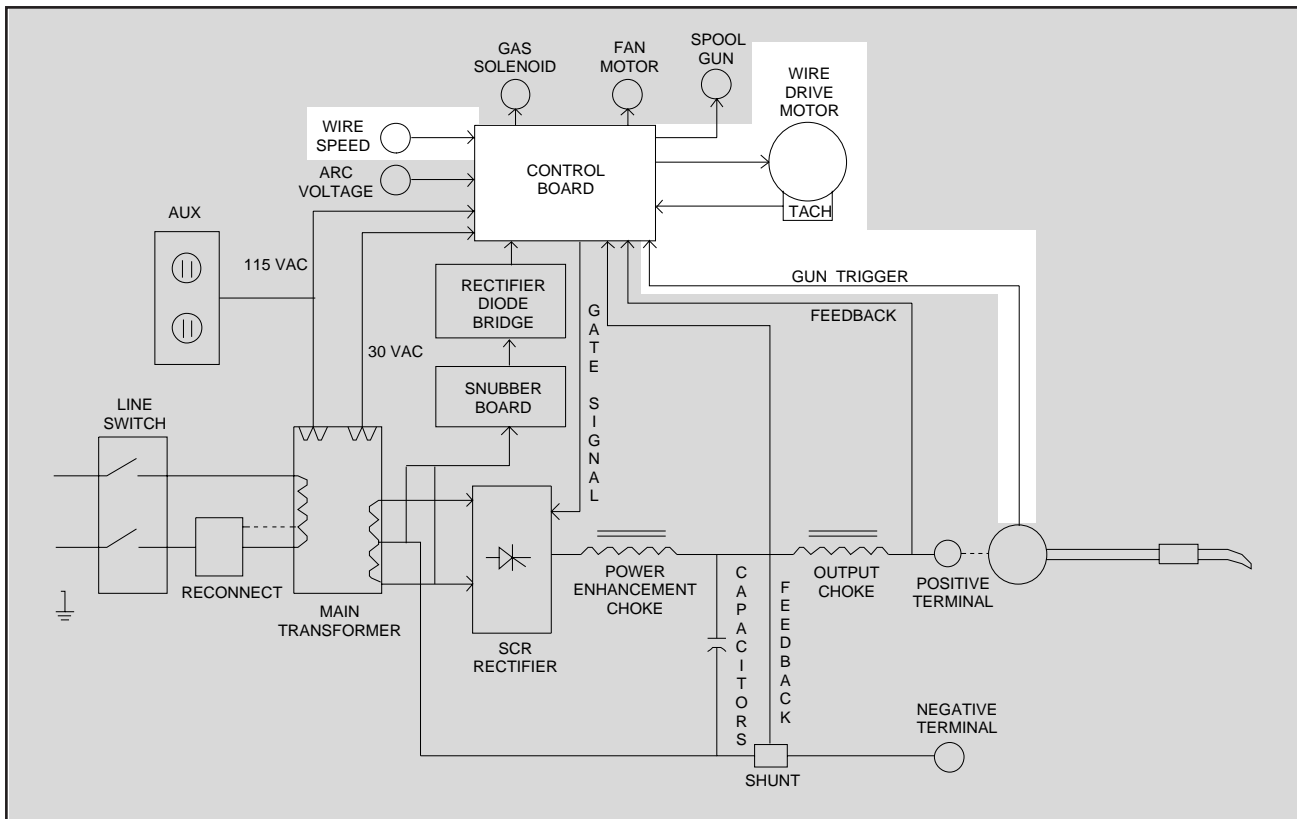

WIRE DRIVE MOTOR AND FEEDBACK

The wire drive motor is controlled by the control board. A motor speed feedback signal is generated at the motor tach and sent to the control board. The control board compares this feedback signal with the commands set forth by the Wire Speed Control potentiometer and sends the appropriate armature voltage to

the wire drive motor. The drive motor speed is thus controlled which in turn regulates the electrode wire feed speed through the gun.

The control board also provides a 3-24 VDC operating voltage for the optional spool gun. To achieve full WFS control at the spool gun, the WFS knob on front of the PM-255C must be set at max.

NOTE: Unshaded areas of Block Logic Diagram are the subject of discussion

POWER MIG 255C

LINCOLN
ELECTRIC

THERMAL AND OVERLOAD PROTECTION

The POWER MIG 255C has built-in protective thermostats that respond to excessive temperatures. One is located on the output choke. The other thermostat is located on the SCR heat sink assembly. They open the wire feed and welder output circuits if the machine exceeds the maximum safe operating temperature. This can be caused by a frequent overload, or high ambient temperature.

The thermostats are self-resetting once the machine cools sufficiently. If the thermostat shutdown is caused by excessive output or duty cycle and the fan is operating normally, the power switch may be left on and the reset should occur within a 15 minute period. If the fan is not turning or the air intake louvers are obstructed, then the input power must be removed and the fan problem or air obstruction be corrected.

OVERCURRENT PROTECTION

The machine will automatically reduce the output if the load on the machine exceeds 300 to 320 amperes. This protects the welding power SCR's from excessive short circuit currents and from exceeding their temperature rating before the thermostats can react.

WIRE FEED OVERLOAD PROTECTION

The POWER MIG has solid state overload protection of the wire drive motor. If the motor becomes overloaded, the protection circuitry turns off the wire feed speed and gas solenoid. Check for proper size tip liner, and drive rolls, for any obstructions or bends in the gun cable, and any other factors that would impede the wire feeding. To resume welding, simply pull the trigger. There is no circuit breaker to reset, as the protection is done with reliable solid state electronics.

Return to Section TOC

Return to Master TOC

Return to Section TOC

Return to Master TOC

Return to Section TOC

Return to Master TOC

Return to Section TOC

Return to Master TOC

POWER MIG 255C



FIGURE E.6 — SCR OPERATION.

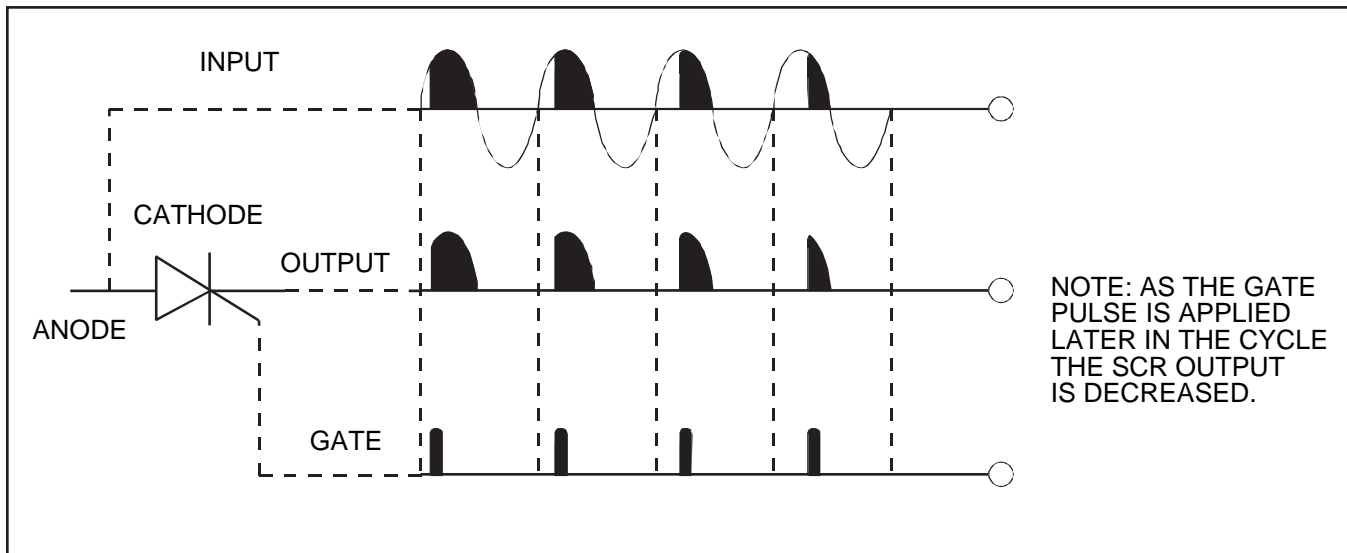

SCR OPERATION

A silicon controlled rectifier (SCR) is a three terminal device used to control rather large currents to a load. An SCR acts very much like a switch. See Figure E.6 for a graphical representation of SCR operation. When a gate signal is applied to the SCR it is turned ON and there is current flow from anode to cathode. In the ON state the SCR acts like a closed switch. When the SCR is turned OFF there is no current flow from anode to cathode thus the device acts like an open switch. As the name suggests, the SCR is a rectifier, so it passes current only during positive half cycles of the AC supply. The positive half cycle is the portion of the sine wave in which the anode of the SCR is more positive than the cathode.

When an AC supply voltage is applied to the SCR, the device spends a certain portion of the AC cycle time in

the off state and the remainder of the time in the on state. The amount of time spent in the ON state is controlled by the gate.

An SCR is fired by a short burst of current into the gate. This gate pulse must be more positive than the cathode voltage. Since there is a standard PN junction between gate and cathode, the voltage between these terminals must be slightly greater than 0.6V. Once the SCR has fired it is not necessary to continue the flow of gate current. As long as current continues to flow from anode to cathode the SCR will remain on. When the anode to cathode current drops below a minimum value, called holding current, the SCR will shut off. This normally occurs as the AC supply voltage passes through zero into the negative portion of the sine wave. If the SCR is turned on early in the positive half cycle, the conduction time is longer resulting in greater SCR output. If the gate firing occurs later in the cycle the conduction time is less resulting in lower SCR output.

Return to Section TOC
Return to Master TOC
Return to Section TOC
Return to Master TOC
Return to Section TOC
Return to Master TOC
Return to Section TOC
Return to Master TOC

POWER MIG 255C



TABLE OF CONTENTS -TROUBLESHOOTING AND REPAIR SECTION-

Troubleshooting and Repair	Section F
How to Use Troubleshooting Guide	F-2
PC Board Troubleshooting Procedures	F-3
Troubleshooting Guide	F-4
Test Procedures	F-11
Main Transformer Test	F-11
Rectifier Diode Bridge Test	F-15
Static SCR Rectifier Assembly Test	F-19
Active SCR Rectifier Assembly Test	F-23
Wire Drive Motor and Tachometer Feedback Test	F-27
Oscilloscope Waveforms	
Normal Open Circuit Voltage Waveform	F-31
Typical Output Voltage Waveform - Machine Loaded	F-32
Abnormal Output Voltage Waveform - Machine Loaded One Output SCR Not Functioning	F-33
Abnormal Open Circuit Voltage Output Capacitor Bank Not Functioning	F-34
Typical SCR Gate Voltage Waveform	F-35
Component Replacement Procedures	F-37
Control PC Board Removal and Replacement	F-37
Wire Drive Assembly Removal and Replacement	F-41
SCR Output Rectifier Removal and Replacement	F-45
Capacitor Bank Removal and Replacement	F-49
Main Transformer and Output Choke Removal and Replacement	F-51
Fan Motor and Fan Removal and Replacement	F-55
Retest After Repair	F-57

HOW TO USE TROUBLESHOOTING GUIDE

⚠ WARNING

Service and Repair should only be performed by Lincoln Electric Factory Trained Personnel. Unauthorized repairs performed on this equipment may result in danger to the technician and machine operator and will invalidate your factory warranty. For your safety and to avoid Electrical Shock, please observe all safety notes and precautions detailed throughout this manual.

This Troubleshooting Guide is provided to help you locate and repair possible machine malfunctions. Simply follow the three-step procedure listed below.

Step 1. LOCATE PROBLEM (SYMPTOM).

Look under the column labeled "PROBLEM (SYMPTOMS)". This column describes possible symptoms that the machine may exhibit. Find the listing that best describes the symptom that the machine is exhibiting. Symptoms are grouped into the following categories: output problems, function problems, wire feeding problems, and welding problems.

Step 2. PERFORM EXTERNAL TESTS.

The second column labeled "POSSIBLE AREAS OF MISADJUSTMENT(S)" lists the obvious external possibilities that may contribute to the machine symptom. Perform these tests/checks in the order listed. In general, these tests can be conducted without removing the case wrap-around cover.

Step 3. RECOMMENDED COURSE OF ACTION

The last column labeled "Recommended Course of Action" lists the most likely components that may have failed in your machine. It also specifies the appropriate test procedure to verify that the subject component is either good or bad. If there are a number of possible components, check the components in the order listed to eliminate one possibility at a time until you locate the cause of your problem.

All of the referenced test procedures referred to in the Troubleshooting Guide are described in detail at the end of this chapter. Refer to the Troubleshooting and Repair Table of Contents to locate each specific Test Procedure. All of the specified test points, components, terminal strips, etc. can be found on the referenced electrical wiring diagrams and schematics. Refer to the Electrical Diagrams Section Table of Contents to locate the appropriate diagram.

⚠ CAUTION

If for any reason you do not understand the test procedures or are unable to perform the tests/repairs safely, contact the Lincoln Electric Service Department for technical troubleshooting assistance before you proceed. Call 1-888-935-3877.

TROUBLESHOOTING & REPAIR

PC BOARD TROUBLESHOOTING PROCEDURES

WARNING



**ELECTRIC SHOCK
can kill.**

- Have an electrician install and service this equipment. Turn the input power OFF at the fuse box before working on equipment. Do not touch electrically hot parts.

CAUTION

Sometimes machine failures appear to be due to PC board failures. These problems can sometimes be traced to poor electrical connections. To avoid problems when troubleshooting and replacing PC boards, please use the following procedure:

1. Determine to the best of your technical ability that the PC board is the most likely component causing the failure symptom.
2. Check for loose connections at the PC board to assure that the PC board is properly connected.
3. If the problem persists, replace the suspect PC board using standard practices to avoid static electrical damage and electrical shock. Read the warning inside the static resistant bag and perform the following procedures:

PC board can be damaged by static electricity.



**ATTENTION
Static-Sensitive
Devices
Handle only at
Static-Safe
Workstations**

- Remove your body's static charge before opening the static-shielding bag. Wear an anti-static wrist strap. For safety, use a 1 Meg ohm resistive cord connected to a grounded part of the equipment frame.

- If you don't have a wrist strap, touch an un-painted, grounded, part of the equipment frame. Keep touching the frame to prevent static build-up. Be sure not to touch any electrically live parts at the same time.

- Tools which come in contact with the PC board must be either conductive, anti-static or static-dissipative.

- Remove the PC board from the static-shielding bag and place it directly into the equipment. Don't set the PC board on or near paper, plastic or cloth which could have a static charge. If the PC board can't be installed immediately, put it back in the static-shielding bag.

- If the PC board uses protective shorting jumpers, don't remove them until installation is complete.

- If you return a PC board to The Lincoln Electric Company for credit, it must be in the static-shielding bag. This will prevent further damage and allow proper failure analysis.

4. Test the machine to determine if the failure symptom has been corrected by the replacement PC board.

NOTE: It is desirable to have a spare (known good) PC board available for PC board troubleshooting.

NOTE: Allow the machine to heat up so that all electrical components can reach their operating temperature.

5. Remove the replacement PC board and substitute it with the original PC board to recreate the original problem.

a. If the original problem does not reappear by substituting the original board, then the PC board was not the problem. Continue to look for bad connections in the control wiring harness, junction blocks, and terminal strips.

b. If the original problem is recreated by the substitution of the original board, then the PC board was the problem. Reinstall the replacement PC board and test the machine.

6. Always indicate that this procedure was followed when warranty reports are to be submitted.

NOTE: Following this procedure and writing on the warranty report, "INSTALLED AND SWITCHED PC BOARDS TO VERIFY PROBLEM," will help avoid denial of legitimate PC board warranty claims.

TROUBLESHOOTING GUIDE

Observe all Safety Guidelines detailed throughout this manual.

PROBLEMS (SYMPTOMS)	POSSIBLE AREAS OF MISADJUSTMENT(S)	RECOMMENDED COURSE OF ACTION
OUTPUT PROBLEMS		
Major Physical or Electrical Damage is Evident	1. Contact your local Lincoln Electric Authorized Field Service Facility.	1. Contact The Lincoln Electric Service Dept. 1-888-935-3877
Machine is dead — no open circuit voltage output and no wire feed when gun trigger is pulled. The machine display may be lit.	<ol style="list-style-type: none"> 1. Make certain that the input power switch is in the "ON" position. 2. Check the input voltage at the machine. Input voltage must match the rating plate and the reconnect panel. 3. Blown or missing fuses in the input line. 4. The thermostats may be open due to machine overheating. If machine operates normally after a cooling off period then check for proper fan operation and ventilation. Make certain that the machine's duty cycle is not being exceeded. 5. Check the trigger circuit. Leads #324 to #325 should have continuity (zero ohms) when the gun trigger is pulled. If not then the gun may be faulty — replace. 6. Make sure the machine is not connected to a portable generator. 	<ol style="list-style-type: none"> 1. Check input power switch (S1). It may be faulty. 2. Check for loose or broken wires at the reconnect panel. 3. Perform Main Transformer Test. 4. Perform Rectifier Diode Bridge Test. 5. Check the thermostats and associated leads for loose or broken connections. See wiring diagram. 6. The control board may be faulty. Replace.

CAUTION

If for any reason you do not understand the test procedures or are unable to perform the tests/repairs safely, contact the Lincoln Electric Service Department for technical troubleshooting assistance before you proceed. Call 1-888-935-3877.

POWER MIG 255C



Observe all Safety Guidelines detailed throughout this manual.

PROBLEMS (SYMPTOMS)	POSSIBLE AREAS OF MISADJUSTMENT(S)	RECOMMENDED COURSE OF ACTION
OUTPUT PROBLEMS (Continued)		
No open circuit voltage output but wire feeds normally when gun trigger is pulled.	<ol style="list-style-type: none"> 1. Check the input voltage at the machine. Input voltage must match the rating plate and the reconnect panel. 2. The gun may be faulty. Check or replace. 	<ol style="list-style-type: none"> 1. Check for loose or broken connections at the output terminals, the chokes, the capacitor bank and all heavy current carrying leads. See Wiring Diagram. 2. Make sure that the transformer secondary leads are securely connected to the SCR rectifier assembly. 3. Perform the SCR Rectifier Assembly Tests. 4. Perform Main Transformer Test. 5. The control board may be faulty. Replace.
Wire feeds but welding output is low causing wire to "stub". Welds are "cold". Machine cannot obtain full rated output of 200 amps at 28 volts.	<ol style="list-style-type: none"> 1. Make sure that the proper wire and procedures are being used. 2. Check gun and work cable for loose or faulty connections. 	<ol style="list-style-type: none"> 1. Check for loose or faulty connections of the heavy current carrying leads. 2. The output capacitor bank may be faulty. Check for loose connections at the capacitors. Also check for leaky capacitors. Replace if necessary. WARNING: The liquid electrolyte in these capacitors is toxic. Avoid contact with any portion of your body. 3. Perform the SCR Rectifier Assembly Tests. 4. Perform the Main Transformer Test. 5. The control board may be faulty. Replace.

⚠ CAUTION

If for any reason you do not understand the test procedures or are unable to perform the tests/repairs safely, contact the Lincoln Electric Service Department for technical troubleshooting assistance before you proceed. Call 1-888-935-3877.

POWER MIG 255C



Observe all Safety Guidelines detailed throughout this manual.

PROBLEMS (SYMPTOMS)	POSSIBLE AREAS OF MISADJUSTMENT(S)	RECOMMENDED COURSE OF ACTION
OUTPUT PROBLEMS (Continued)		
The output voltage and wire feed is present continuously or pulsing when gun trigger is NOT activated.	<ol style="list-style-type: none"> 1. Remove the gun. If the problem is resolved the gun trigger circuit is faulty. Repair or replace. 2. If problem persists when gun assembly is removed from machine, then the problem is within the POWER MIG 255C. 	<ol style="list-style-type: none"> 1. Check the machine's internal trigger leads for grounds or shorts. See Wiring Diagram. 2. The control board may be faulty. Replace.
The output voltage is present continuously when gun trigger is NOT activated.	Contact your local Lincoln Electric Authorized Field Service Facility.	<ol style="list-style-type: none"> 1. Perform the SCR Rectifier Assembly Tests. 2. The control board may be faulty. Replace.

⚠ CAUTION

If for any reason you do not understand the test procedures or are unable to perform the tests/repairs safely, contact the Lincoln Electric Service Department for technical troubleshooting assistance before you proceed. Call 1-888-935-3877.

POWER MIG 255C



Observe all Safety Guidelines detailed throughout this manual.

PROBLEMS (SYMPTOMS)	POSSIBLE AREAS OF MISADJUSTMENT(S)	RECOMMENDED COURSE OF ACTION
FUNCTION PROBLEMS		
No control of arc voltage. Wire feeding is normal.	<ol style="list-style-type: none"> 1. The arc voltage control potentiometer may be dirty. Rotate several times and check if problem is resolved. 	<ol style="list-style-type: none"> 1. The arc voltage control potentiometer may be faulty. Check or replace. See Wiring Diagram. 2. Perform the SCR Rectifier Assembly Tests. 3. The control board may be faulty. Replace.
There is no gas flow when gun trigger is pulled. Wire feeds and weld voltage is present.	<ol style="list-style-type: none"> 1. Check gas source and hoses for leaks or kinks. 	<ol style="list-style-type: none"> 1. Check the gas solenoid by disconnecting it from the control board (Plug J8) and applying a 12 VDC external supply to the gas solenoid. If the solenoid does NOT activate then it may be faulty. Replace. 2. The control board may be faulty. Replace.
The machine stops feeding wire while welding.	<ol style="list-style-type: none"> 1. Check for adequate wire supply. 2. Check for mechanical restrictions in the wire feeding path. The gun may be clogged. 3. Check gun liner and tip are correct for wire size being used. 4. Check spindle for ease of rotation. 5. If Timer Option Kit is installed, make sure spot timer knob is set to OFF. 	<ol style="list-style-type: none"> 1. Check the motor armature current. Normal armature current is 2.0 to 2.7 amps maximum. If the motor armature current is normal the control board may be faulty. Replace. 2. If the motor armature current is high (over 2.7 amps) and there are NO restrictions in the wire feeding path then the motor or gear box may be defective. Replace.

CAUTION

If for any reason you do not understand the test procedures or are unable to perform the tests/repairs safely, contact the Lincoln Electric Service Department for technical troubleshooting assistance before you proceed. Call 1-888-935-3877.

POWER MIG 255C



Observe all Safety Guidelines detailed throughout this manual.

PROBLEMS (SYMPTOMS)	POSSIBLE AREAS OF MISADJUSTMENT(S)	RECOMMENDED COURSE OF ACTION
WIRE FEEDING PROBLEMS		
No control of wire feed speed. Other machine functions are normal	<ol style="list-style-type: none"> 1. The wire feed speed control may be dirty. Rotate several times and check if problem is resolved. 	<ol style="list-style-type: none"> 1. The Wire Speed Control potentiometer may be faulty. Check or replace. See Wiring Diagram. 2. Perform the Wire Drive Motor and Tachometer Feedback Test. 3. The control board may be faulty. Replace.
There is no wire feed when gun trigger is pulled. Normal open circuit voltage is present.	<ol style="list-style-type: none"> 1. Check for adequate wire supply. 2. If the drive rolls are turning then check for a mechanical restriction in the wire feed path. 3. The gun liner may be clogged. Check or replace. 4. If the drive rolls are NOT turning when the gun trigger is pulled then contact your local Lincoln Electric Authorized Field Service Facility. 	<ol style="list-style-type: none"> 1. Perform the Wire Drive Motor and Tachometer Feedback Test. 2. The Wire Feed Control potentiometer may be faulty. Check or replace. See Wiring Diagram. 3. The control board may be faulty. Replace.

⚠ CAUTION

If for any reason you do not understand the test procedures or are unable to perform the tests/repairs safely, contact the Lincoln Electric Service Department for technical troubleshooting assistance before you proceed. Call 1-888-935-3877.

POWER MIG 255C



Observe all Safety Guidelines detailed throughout this manual.

PROBLEMS (SYMPTOMS)	POSSIBLE AREAS OF MISADJUSTMENT(S)	RECOMMENDED COURSE OF ACTION
WELDING PROBLEMS		
The arc is unstable and or "hunting".	<ol style="list-style-type: none"> 1. Check for worn or melted contact tip. 2. Check for loose or faulty connections on the work and electrode cables. 3. Make sure electrode polarity or welding process being used, is correct. 4. Check for rusty or dirty wire. 5. Make sure machine settings and gas are correct for process being used. 	<ol style="list-style-type: none"> 1. Check for loose connections at the output terminals, the chokes, the capacitor bank and all heavy current carrying leads. See Wiring Diagram. 2. Make sure that the transformer secondary leads are securely connected to the SCR rectifier assembly. 3. The output capacitor bank may be faulty. Check for loose connections at the capacitors. Also check for leaky capacitors. Replace if necessary. WARNING: The liquid electrolyte in these capacitors is toxic. Avoid contact with any portion of your body. 4. Perform the <i>SCR Rectifier Assembly Tests</i>. 5. The control board may be faulty. Replace.
Weld bead is narrow or ropy. May have porosity with electrode stubbing into plate.	<ol style="list-style-type: none"> 1. Make sure the weld procedure and electrode polarity is correct for the process being used. 2. Make sure shielding gas is correct and flow is proper. 3. Make sure the weld joint is not "contaminated". 	<ol style="list-style-type: none"> 1. The output capacitor bank may be faulty. Check for loose connections at the capacitors. Also check for leaky capacitors. Replace if necessary. WARNING: The liquid electrolyte in these capacitors is toxic. Avoid contact with any portion of your body. 2. The control board may be faulty. Replace.

 **CAUTION**

If for any reason you do not understand the test procedures or are unable to perform the tests/repairs safely, contact the Lincoln Electric Service Department for technical troubleshooting assistance before you proceed. Call 1-888-935-3877.

POWER MIG 255C



Observe all Safety Guidelines detailed throughout this manual.

PROBLEMS (SYMPTOMS)	POSSIBLE AREAS OF MISADJUSTMENT(S)	RECOMMENDED COURSE OF ACTION
WELDING PROBLEMS (Continued)		
The contact tip seizes in the gas diffuser.	<ol style="list-style-type: none"> 1. The tip being over heated due to excessive current and/or high duty cycle welding. 2. A light application of high temperature anti-sieze lubricant (such as Lincoln E2607 Graphite Grease) may be applied to the contact tip threads. 	<ol style="list-style-type: none"> 1. Make sure tip is tight in diffuser.
The welding arc is variable and sluggish.	<ol style="list-style-type: none"> 1. Check the welding cable connections for loose or faulty connections. 2. Make sure the wire feed speed, voltage, and shielding gas are correct for the process being used. 	<ol style="list-style-type: none"> 1. Perform the SCR Rectifier Assembly Tests. 2. The control board may be faulty. Replace.
The arc striking is poor.	<ol style="list-style-type: none"> 1. Check the welding cable connections for loose or faulty connections. 2. Make sure the wire feed speed, voltage, and shielding gas are correct for the process being used. 	<ol style="list-style-type: none"> 1. The output capacitor bank may be faulty. Check for loose connections at the capacitors. Also check for leaky capacitors. Replace if necessary. WARNING: The liquid electrolyte in these capacitors is toxic. Avoid contact with any portion of your body. 2. The control board may be faulty. Replace.

 **CAUTION**

If for any reason you do not understand the test procedures or are unable to perform the tests/repairs safely, contact the Lincoln Electric Service Department for technical troubleshooting assistance before you proceed. Call 1-888-935-3877.

POWER MIG 255C



TEST PROCEDURES

MAIN TRANSFORMER TEST

WARNING

Service and repair should only be performed by Lincoln Electric factory trained personnel. Unauthorized repairs performed on this equipment may result in danger to the technician or machine operator and will invalidate your factory warranty. For your safety and to avoid electrical shock, please observe all safety notes and precautions detailed throughout this manual.

If for any reason you do not understand the test procedures or are unable to perform the test/repairs safely, contact the Lincoln Electric service department for technical troubleshooting assistance before you proceed. Call 1-888-935-3877.

TEST DESCRIPTION

This test will determine if the correct voltages are being:

- a. Applied to the primary windings of the main transformer.
- b. Induced on the secondary and auxiliary windings of the main transformer.

MATERIALS NEEDED

3/8 in. Nutdriver
5/16 in. Nutdriver
Volt-ohmmeter

MAIN TRANSFORMER TEST (continued)

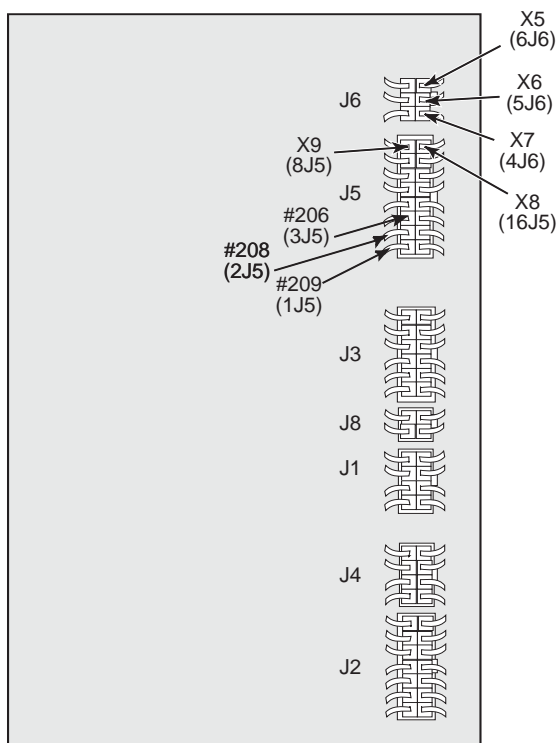
FIGURE F.1 — G3521 CONTROL PC BOARD AND M19248 SNUBBER PC BOARD
MAIN TRANSFORMER TEST POINTS.

TEST PROCEDURE

 **WARNING**

The ON/OFF POWER SWITCH will be "hot" during these tests.

NOTE: Secondary voltages will vary proportionately with the primary input voltage.

1. Disconnect the main input power supply to the machine.
2. Remove the case top and side panels with a 3/8 in. nutdriver.
3. Remove the tool tray with a 5/16 in. nutdriver.

4. Locate plug J6 on the control PC board. See Figure F.1.

NOTE: The location of plugs may vary depending on the machine code.

5. Locate the following leads on plug J6 on the control PC board:

LEAD	PLUG LOCATION
X5	6J6
X6	5J6
X7	4J6

POWER MIG 255C



MAIN TRANSFORMER TEST (continued)

6. Connect main input power to the machine.
7. Turn the POWER MIG 255C ON/OFF POWER SWITCH to ON.
8. Carefully make the following voltage tests at plug J6.
 - a. Turn the machine OFF between each test.
 - b. Carefully insert the meter probes into the back of each Molex plug pin cavity to perform the test.

FROM LEAD	TO LEAD	EXPECTED VOLTAGE
X5 (6J6)	X6 (5J6)	15VAC
X5 (6J6)	X7 (4J6)	30VAC
X6 (5J6)	X7 (4J6)	15VAC

9. Turn OFF the machine.
10. Locate the following leads on plug J5 on the Control PC board. See **Figure F.1**.

LEAD	PLUG LOCATION
X8 X9	16J5 8J5

11. Turn the machine ON.
12. Make the following voltage tests at plug J5.
 - a. Turn the machine OFF between each test.
 - b. Carefully insert the meter probes into the back of each Molex plug pin cavity to perform the test.

FROM LEAD	TO LEAD	EXPECTED VOLTAGE
X8 (16J5)	X9 (8J5)	115VAC

- c. If the voltage tested is incorrect, check for loose or broken leads between the test points and the main transformer.
 - d. If the voltage is not corrected, go to step 16.
13. Turn OFF the machine power.

MAIN TRANSFORMER TEST (continued)

14. Locate the following leads on plug J5 on the Control PC board. See **Figure F.1**.

LEAD	PLUG LOCATION
206	3J5

LEAD	PLUG LOCATION
208	2J5
209	1J5

15. Turn the machine ON.
16. Make the following voltage tests at plug J5 on the Control PC board.
- Turn the machine OFF between each test.
 - Carefully insert the meter probes into the back of each Molex plug pin cavity to perform the test.
 - If any of the voltages tested are incorrect, check for loose or broken leads between the test points and the main transformer.

FROM LEAD	TO LEAD	EXPECTED VOLTAGE
208 (2J5)	209 (1J5)	56VAC
208 (2J5)	206	28VAC
209 (1J5)	206	28VAC

- If ALL the voltages tested are incorrect or missing, go to step 16.

17. Test for correct nameplate input voltage between the H1 lead at the ON/OFF POWER SWITCH to H2 or H3 (H5 if connected for 575 VAC) at the reconnect panel. Voltage tested will vary depending on input voltage connection. See wiring diagram for test point locations.

- If the voltage test is incorrect,

-check for loose or broken leads between the reconnect panel and the ON/OFF POWER SWITCH.

-test the ON/OFF POWER SWITCH for proper operation.

- If the correct nameplate voltage is being applied to the main transformer and one or more of the secondary voltages are missing or are incorrect, the main transformer may be faulty. Replace.

RECTIFIER DIODE BRIDGE TEST

 **WARNING**

Service and repair should only be performed by Lincoln Electric factory trained personnel. Unauthorized repairs performed on this equipment may result in danger to the technician or machine operator and will invalidate your factory warranty. For your safety and to avoid electrical shock, please observe all safety notes and precautions detailed throughout this manual.

If for any reason you do not understand the test procedures or are unable to perform the test/repairs safely, contact the Lincoln Electric service department for technical troubleshooting assistance before you proceed. Call 1-888-935-3877.

TEST DESCRIPTION

This test will determine if the correct voltages are being:

- a. Applied to the diode bridge.
- b. Supplied from diode bridge to the control PC board.

MATERIALS NEEDED

3/8 in. Nutdriver

Volt-ohmmeter

POWER MIG 255C wiring diagrams (See *Electrical Diagrams* Section of this Manual)

RECTIFIER DIODE BRIDGE TESTING (continued)

FIGURE F.2 — G3521 RECTIFIER DIODE BRIDGE LOCATION.

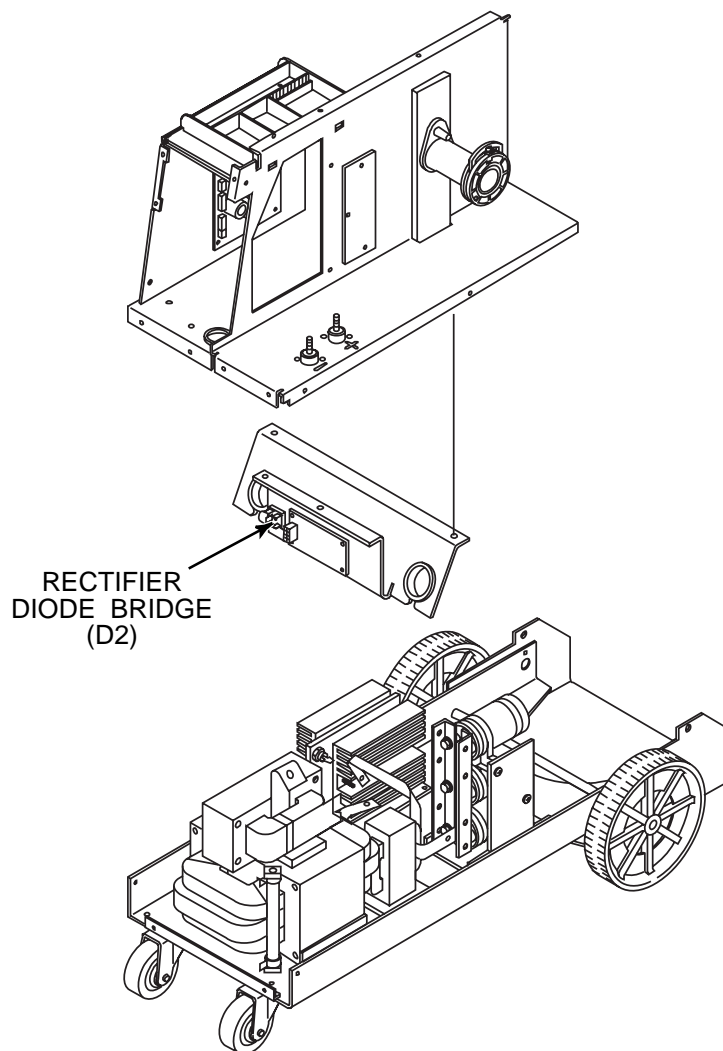

TEST PROCEDURE

1. Disconnect the main AC input power to the machine.
2. Remove the case top and side panels with a 3/8 in. nutdriver.
3. Perform the **Main Transformer Test** to ensure the proper voltages are supplied to the J5 plug on the Control board.
4. Locate the following leads:

LEAD
208
209
354
206

Leads #208, #209, and #354 are connected to the rectifier diode bridge (D2). See Figure F.2. Lead #206 is connected at the output shunt. See the wiring diagram.

5. Connect main input power to the machine.

POWER MIG 255C



RECTIFIER DIODE BRIDGE TESTING *(continued)*

6. Turn the POWER MIG 255C ON/OFF POWER SWITCH to ON.
7. Carefully make the following voltage tests:
 - a. Turn the machine OFF between each test.
 - b. Carefully connect the meter plugs to the exposed lead connections.
 - c. Turn the machine ON to conduct the voltage test at J5 connector Control board

FROM LEAD	TO LEAD	EXPECTED VOLTAGE
208	206	28 VAC
209	206	28 VAC

8. If any of the AC voltages tested are incorrect or missing, check the leads and connections. See the wiring diagram.

9. Make the following voltage test:
 - a. Turn the machine OFF between each test.
 - b. Carefully connect the meter probes to the exposed lead connections.
 - c. Turn the machine ON to conduct the voltage test.

FROM LEAD	TO LEAD	EXPECTED VOLTAGE
354	206	36 VDC

10. If the DC voltage tested is incorrect or missing, and the AC voltages are correct, the rectifier diode bridge may be faulty.

Return to Section TOC
Return to Master TOC
Return to Section TOC
Return to Master TOC
Return to Section TOC
Return to Master TOC
Return to Section TOC
Return to Master TOC

POWER MIG 255C



STATIC SCR RECTIFIER ASSEMBLY TEST

⚠ WARNING

Service and repair should only be performed by Lincoln Electric factory trained personnel. Unauthorized repairs performed on this equipment may result in danger to the technician or machine operator and will invalidate your factory warranty. For your safety and to avoid electrical shock, please observe all safety notes and precautions detailed throughout this manual.

If for any reason you do not understand the test procedures or are unable to perform the test/repairs safely, contact the Lincoln Electric service department for technical troubleshooting assistance before you proceed. Call 1-888-935-3877.

TEST DESCRIPTION

This test is used to quickly determine if an SCR or diode is shorted or "leaky." See the Machine Waveform Section in this manual for normal and abnormal output waveforms.

MATERIALS NEEDED

Analog Volt-ohmmeter
POWER MIG 255C wiring diagrams (See *Electrical Diagrams* Section of this Manual)
3/8 in. Nutdriver
5/16 in. Nutdriver
1/2 in. Open end or socket wrench

STATIC SCR RECTIFIER ASSEMBLY TEST *(continued)*

FIGURE F.3 — REMOVE PLUGS J6 AND J5 TO PERFORM STATIC RECTIFIER ASSEMBLY TEST.

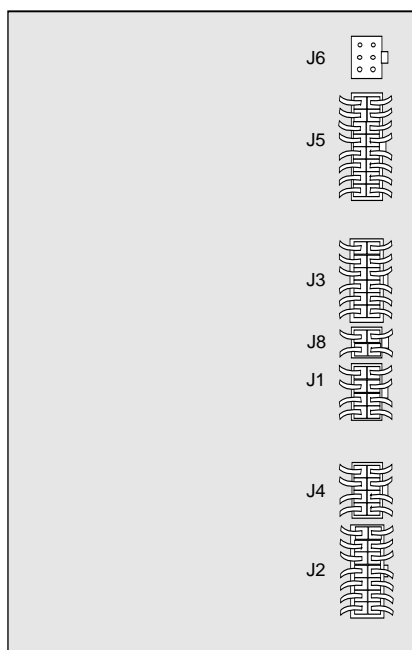
**TEST PROCEDURE**

1. Disconnect main AC input power to the machine.
2. Remove the case top and side panels with a 3/8 in. nutdriver.
3. Remove the tool tray with a 5/16 in. nutdriver.
4. Verify that the capacitors have completely discharged with a volt-ohmmeter.
5. Disconnect plugs J6 and J5 from the control board. This electrically isolates the SCR bridge assembly. See Figure F.3.

STATIC SCR RECTIFIER ASSEMBLY TEST (continued)

FIGURE F.4 — LOCATION OF LEADS X2 AND X3.

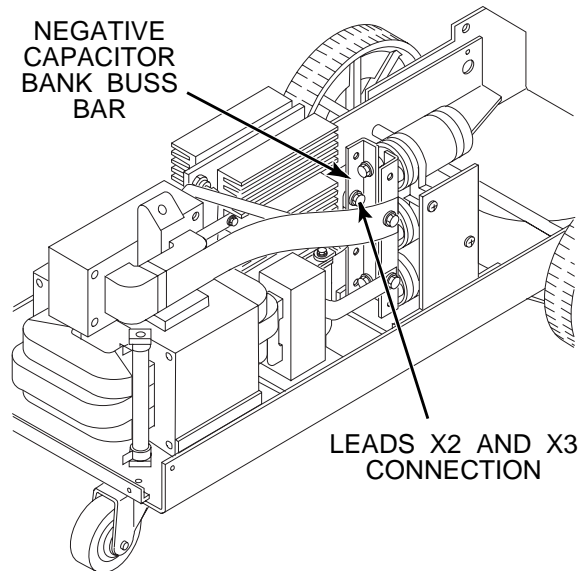
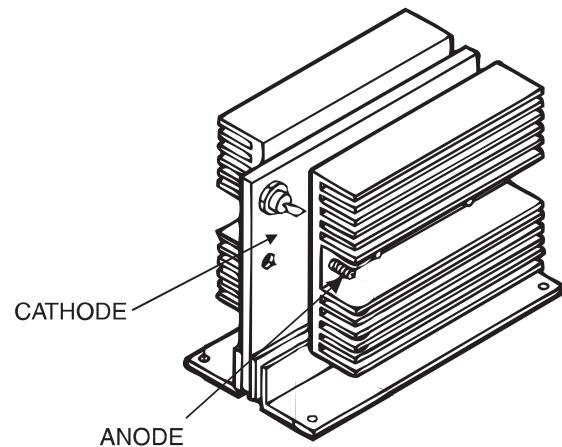

FIGURE F.5 — SCR 1 TEST POINTS.



6. Disconnect leads X2 and X3 (braided copper strap) from the negative capacitor bank buss bar using a 1/2 in. open end wrench. See Figure F.4.
7. Separate leads X2 and X3 from the negative capacitor bank buss bar. Be sure there is no electrical contact.

NOTE: DO NOT DISASSEMBLE THE SCR RECTIFIER HEAT SINK ASSEMBLY.

8. Test for high or infinite resistance from the anode to the cathode of SCR 1 using an analog ohmmeter. See Figure F.5.

9. Test for high or infinite resistance from the cathode to the anode of SCR 1 by reversing the meter leads. See Figure F.5.

- a. If a high or infinite resistance is indicated for both tests 6 and 7, the SCR 1 is not "shorted".
- b. If a low resistance is indicated in either tests 6 or 7, the SCR is faulty. Replace the SCR assembly.

10. Repeat steps 6 and 7 to test SCR 2.
11. Reconnect leads X2 and X3 (braided copper strap).
12. Reconnect plugs J5 and J6.
13. If this test did not identify the problem, or to further test the SCR, go to the **Active SCR Rectifier Assembly Test**.

Return to Section TOC
Return to Master TOC
Return to Section TOC
Return to Master TOC
Return to Section TOC
Return to Master TOC
Return to Section TOC
Return to Master TOC

POWER MIG 255C



ACTIVE SCR RECTIFIER ASSEMBLY TEST

⚠ WARNING

Service and repair should only be performed by Lincoln Electric factory trained personnel. Unauthorized repairs performed on this equipment may result in danger to the technician or machine operator and will invalidate your factory warranty. For your safety and to avoid electrical shock, please observe all safety notes and precautions detailed throughout this manual.

If for any reason you do not understand the test procedures or are unable to perform the test/repairs safely, contact the Lincoln Electric service department for technical troubleshooting assistance before you proceed. Call 1-888-935-3877.

TEST DESCRIPTION

The Active SCR Rectifier Assembly Test will determine if the device is able to be gated ON and conduct current from anode to cathode.

The Static SCR Rectifier Assembly Test must be performed before proceeding with the Active SCR Test.

MATERIALS NEEDED

3/8 in. Nutdriver

5/16 in. Nutdriver

An SCR Tester as specified in this procedure

POWER MIG 255C wiring diagrams (See *Electrical Diagrams* Section of this Manual)

SCR Heat Sink Assembly Drawings

A volt-ohmmeter

ACTIVE SCR RECTIFIER ASSEMBLY TEST *(continued)*

FIGURE F.6 — CONTROL BOARD MOLEX PLUG LOCATIONS FOR G3521 PC CONTROL BOARD.

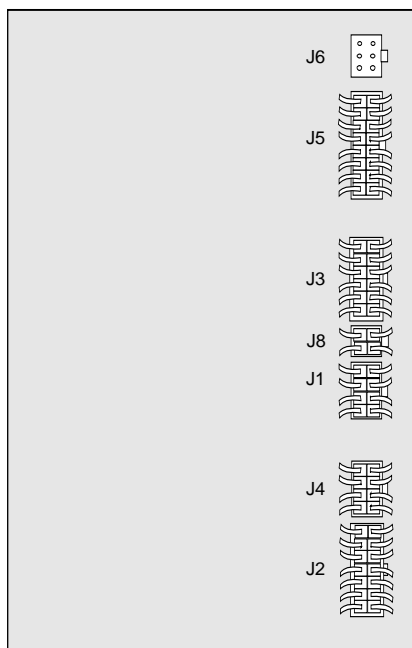
**TEST PROCEDURE**

1. Disconnect main AC input power to the machine.
2. Remove the case top and side panels with a 3/8 in. nutdriver.
3. Remove the tool tray with a 5/16 in. nutdriver.
4. Verify that the capacitors have completely discharged with a volt-ohmmeter.
5. Disconnect plugs J6 and J5 control board. This electrically isolates the SCR bridge assembly. See Figure F.6.

ACTIVE SCR RECTIFIER ASSEMBLY TEST (continued)

6. Disconnect leads X2 and X3 (braided copper strap) from the negative capacitor bank buss bar using a 1/2 in. open end wrench. See Figure F.7.

FIGURE F.7 — LOCATION OF LEADS X2 AND X3.

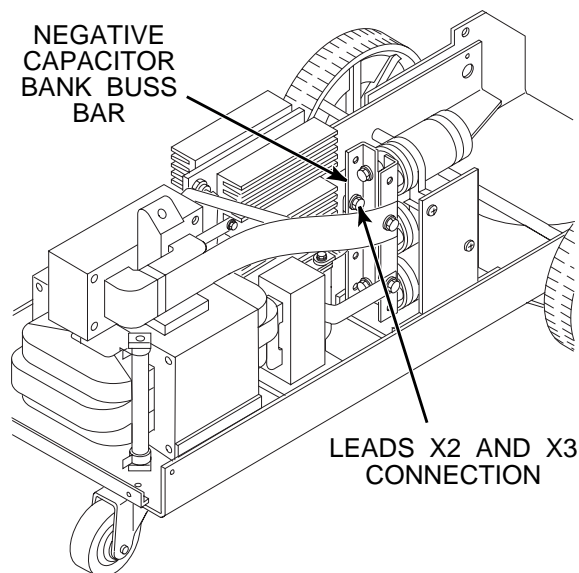

7. Separate leads X2 and X3 from the negative capacitor bank buss bar. Be sure there is no electrical contact.

NOTE: DO NOT DISASSEMBLE THE SCR RECTIFIER HEAT SINK ASSEMBLY.

8. Use a commercial SCR tester or construct the tester circuit shown in Figure F.8. One 6-volt lantern battery can be used. R1 and R2 resistor values are $\pm 10\%$. Set voltmeter scale low, at approximately 0-5 volts or 5-10 volts.

- a. Test the voltage level of the battery. Short leads (A) and (C). Close switch SW-1. Battery voltage should be 4.5 volts or higher. If lower, replace the battery.

FIGURE F.8 — SCR TESTER CIRCUIT AND SCR CONNECTIONS.

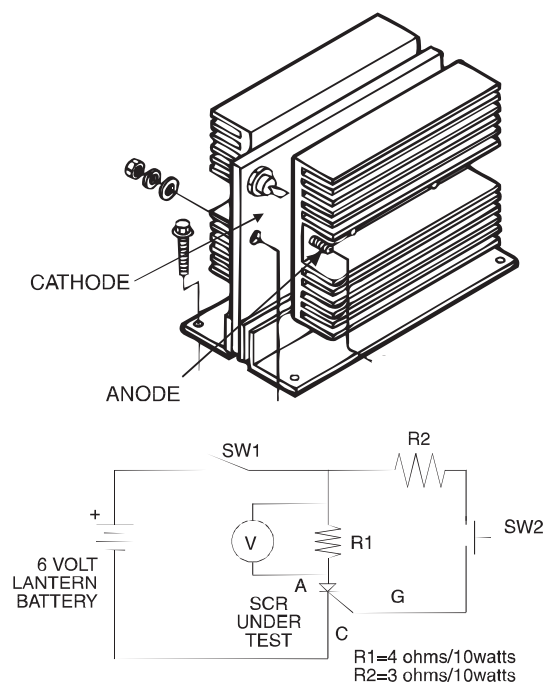

To test SCR's construct the circuit outlined above. Resistor values are plus or minus ten percent. The voltmeter scale should be low, approximately 0-5 or 0-10 volts DC.

ACTIVE SCR RECTIFIER ASSEMBLY TEST (continued)

9. Connect the tester to the SCR 1 as shown in Figure F.8.
 - a. Connect tester lead (A) to the anode.
 - b. Connect tester lead (C) to the cathode.
 - c. Connect tester lead (G) to the gate.
10. Close switch SW-1.

NOTE: Switch SW-2 should be open.
11. Read meter for zero voltage.
 - a. If the voltage reading is higher than zero, the SCR is shorted.
12. Close or keep closed switch SW-1.
13. Close switch SW-2 for 2 seconds and release and read meter.
 - a. If the voltage is 3 to 6 volts while the switch is closed and after the switch is open, the SCR is functioning.
 - b. If the voltage is 3 to 6 volts only when the switch is closed or there is no voltage when the switch is closed, the SCR is defective.

NOTE: Be sure battery is functioning properly. A low battery can affect the results of the test. Repeat Battery Test Procedure in Step 6 if needed.
14. Open switch SW-1.
15. Reconnect the tester leads. See **Figure F.8**.
 - a. Connect tester lead (A) to the cathode.
 - b. Connect tester lead (C) to the anode.
 - c. Disconnect test lead (G) from the gate.
16. Close switch SW-1.
17. Read meter for zero voltage.
 - a. If the voltage is zero, the SCR is functioning.
 - b. If the voltage is higher than zero, the SCR is shorted.
18. Perform the Active Test Procedure outlined in Steps 6-15 for SCR 2.
19. Replace all SCR assemblies that do not pass the above tests.
20. Reconnect plug J6 onto the control PC board and J9 to the snubber PC board.
21. Reconnect leads X2 and X3 to the negative capacitor bank bus bar.
22. Replace the tool tray and case sides.

WIRE DRIVE MOTOR AND TACHOMETER FEEDBACK TEST**⚠ WARNING**

Service and repair should only be performed by Lincoln Electric factory trained personnel. Unauthorized repairs performed on this equipment may result in danger to the technician or machine operator and will invalidate your factory warranty. For your safety and to avoid electrical shock, please observe all safety notes and precautions detailed throughout this manual.

If for any reason you do not understand the test procedures or are unable to perform the test/repairs safely, contact the Lincoln Electric service department for technical troubleshooting assistance before you proceed. Call 1-888-935-3877.

TEST DESCRIPTION

This test will determine if the wire drive motor and voltage feedback circuit are functioning properly.

MATERIALS NEEDED

5/16 in. Nutdriver
Volt-Ohmmeter

Return to Section TOC
Return to Master TOC

Return to Section TOC
Return to Master TOC

Return to Section TOC
Return to Master TOC

Return to Section TOC
Return to Master TOC

POWER MIG 255C



WIRE DRIVE MOTOR AND TACHOMETER FEEDBACK TEST *(continued)*

FIGURE F.9 — PLUG J1 LOCATION ON CONTROL PC BOARD.

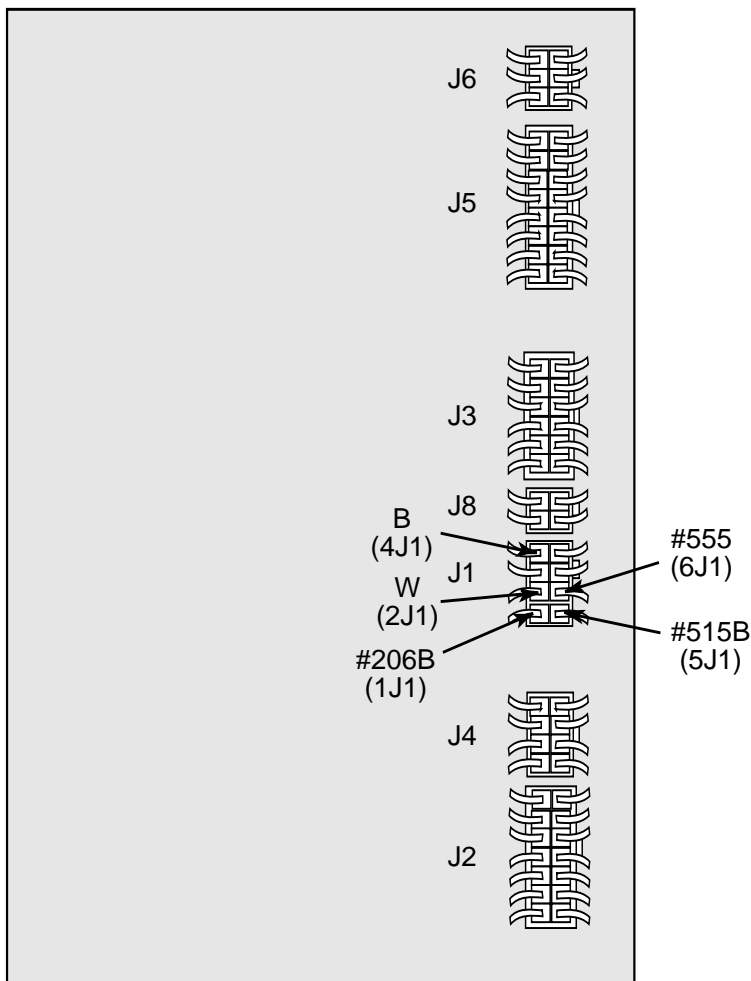

TEST PROCEDURE

NOTE: POLARITY MUST BE OBSERVED FOR THESE TESTS.

Test for Correct Wire Drive Motor Armature Voltage

1. Disconnect main input power to the machine.
2. Open the side panels and remove the tool tray using a 5/16 in. nutdriver.

3. Locate plug J1 on the control PC board. See Figure F.9.
4. Locate the following leads on plug J1:

LEAD	PLUG LOCATION
B	4J1
W	2J1

5. Connect the main power to the machine.

WIRE DRIVE MOTOR AND TACHOMETER FEEDBACK TEST *(continued)*

6. Make the following voltage tests:
 - a. Turn the machine OFF between each test.
 - b. Carefully insert the meter probes into the back of each Molex plug pin cavity to perform the test.
 - c. Turn the machine ON and pull the gun trigger to conduct the voltage test.

FROM LEAD	TO LEAD	EXPECTED VOLTAGE
B (4J1)	W (2J1)	3-20 VDC (varies depending on wire feed speed)

7. If the voltage to the wire drive motor armature is zero, check the wires between plug J1 and the wire drive motor. Also check the electrical connector J12 for proper connection and contact.
8. If all wires and connectors are good and the voltage to the drive motor armature is zero, the control PC board may be faulty, replace the control PC board.
9. If the motor is running at high speed and the armature voltage is high and uncontrollable, proceed with the tachometer test.

TEST FOR SUPPLY VOLTAGE TO TACHOMETER

1. Disconnect the main AC input power to the machine.

2. Locate plug J1 on the control PC board. See **Figure F.9**.
3. Locate the following leads on Plug J1:

LEAD	PLUG LOCATION
515B 206B	5J1 1J1

4. Connect main input power to the machine.
5. Make the following voltage tests:
 - a. Turn the machine OFF between each test.
 - b. Carefully insert the meter probes into the back of each Molex plug pin cavity.

FROM LEAD	TO LEAD	EXPECTED VOLTAGE
515B (5J1)	206B (1J1)	15 VDC

6. If the 15 VDC is present, check the leads to the tachometer circuit.
7. If the leads are okay and 15 VDC is present, the correct voltage is being received from the control PC board, continue with the Supply Voltage to Tachometer Test.
8. If the 15 VDC is not present and the leads are okay, the control PC board may be faulty, replace the control PC board.

WIRE DRIVE MOTOR AND TACHOMETER FEEDBACK TEST *(continued)*

TEST FOR FEEDBACK VOLTAGE TO CONTROL BOARD

1. Disconnect the main AC input power to the machine.
2. Locate plug J1 on the control PC board.
3. Locate the following leads on plug J1 (*see Figure F.9*):

LEAD	PLUG LOCATION
555 206B	6J1 1J1

4. Connect main input power to the machine.
5. Make the following voltage tests:
 - a. Turn the machine OFF between each test.
 - b. Carefully insert the meter probes into the back of each Molex plug pin cavity.
 - c. Turn the machine ON and pull the

gun trigger to conduct the voltage test.

FROM LEAD	TO LEAD	EXPECTED VOLTAGE
555 (6J1)	206B (1J1)	1.5 to 3.5 VDC

6. If the 1.5 to 3.5 VDC is present, the tachometer circuit is sending the correct feedback signal to the Control PC Board.
7. If the 1.5 to 3.5 VDC is not present or not correct, the Control PC Board is not receiving the proper feedback voltage from the tachometer circuit. Check the leads from the tachometer circuit to the control PC board for loose or broken connections.
8. If the leads are okay, the tachometer circuit may be faulty, replace the tachometer circuit.
9. Replace the tool tray.

TYPICAL OUTPUT VOLTAGE WAVEFORM - MACHINE LOADED

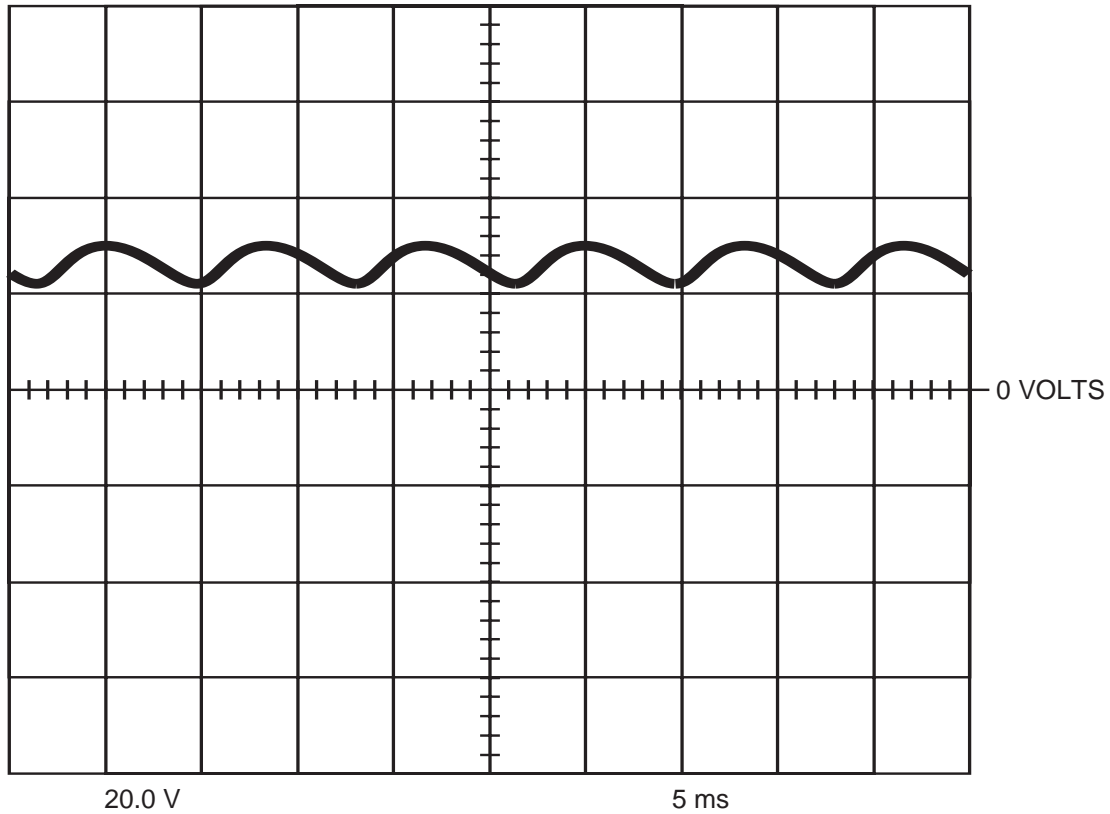

MACHINE LOADED TO 250 AMPS AT 26 VDC

SCOPE SETTINGS

This is a typical DC output voltage waveform generated from a properly operating machine. Note that each vertical division represents 20 volts and that each horizontal division represents 5 milliseconds in time. The machine was loaded with a resistance grid bank. NOTE: Scope probes connected at machine output terminals: (+) probe to electrode, (-) probe to work.	Volts/Div 20 V/Div
	Horizontal Sweep 5 ms/Div
	Coupling DC
	Trigger Internal

Return to Section TOC

Return to Master TOC

Return to Section TOC

Return to Master TOC

Return to Section TOC

Return to Master TOC

Return to Section TOC

Return to Master TOC

**ABNORMAL OPEN CIRCUIT VOLTAGE
OUTPUT CAPACITOR BANK NOT FUNCTIONING**

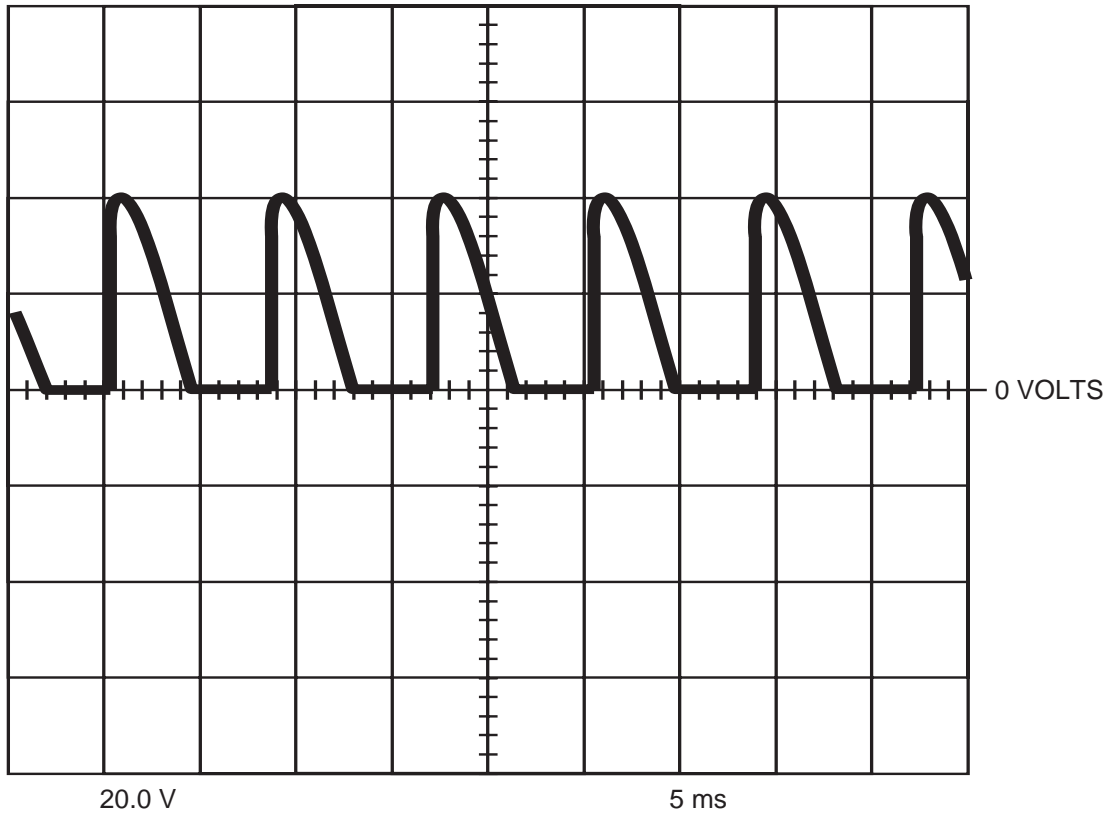

SCOPE SETTINGS

<p>This is NOT the typical DC output voltage waveform. The output capacitors are not functioning. Note the lack of “filtering” in the output waveform. The output capacitor bank was disconnected. Each vertical division represents 20 volts and each horizontal division represents 5 milliseconds in time.</p> <p>NOTE: Scope probes connected at machine output terminals: (+) probe to electrode, (-) probe to work.</p>	Volts/Div 20 V/Div
	Horizontal Sweep 5 ms/Div
	Coupling DC
	Trigger Internal

Return to Section TOC
Return to Section TOC
Return to Section TOC
Return to Section TOC
Return to Section TOC
Return to Section TOC

Return to Master TOC
Return to Master TOC
Return to Master TOC
Return to Master TOC
Return to Master TOC
Return to Master TOC

Return to Section TOC
Return to Master TOC
Return to Section TOC
Return to Master TOC
Return to Section TOC
Return to Master TOC
Return to Section TOC
Return to Master TOC

POWER MIG 255C



COMPONENT REPLACEMENT PROCEDURES

CONTROL PC BOARD REMOVAL AND REPLACEMENT

WARNING

Service and repair should only be performed by Lincoln Electric factory trained personnel. Unauthorized repairs performed on this equipment may result in danger to the technician or machine operator and will invalidate your factory warranty. For your safety and to avoid electrical shock, please observe all safety notes and precautions detailed throughout this manual.

If for any reason you do not understand the test procedures or are unable to perform the test/repairs safely, contact the Lincoln Electric service department for technical troubleshooting assistance before you proceed. Call 1-888-935-3877.

CAUTION

Printed Circuit Boards can be damaged by static electricity. Follow static handling guidelines detailed in "PC Board Troubleshooting Procedures" at the beginning of this chapter.

DESCRIPTION

This procedure will aid the technician in the removal and replacement of the control PC board.

MATERIALS NEEDED

5/16 in. Nutdriver
Static electricity grounding strap

CONTROL PC BOARD REMOVAL AND REPLACEMENT *(continued)*

FIGURE F.10 — WIRING HARNESS AND MOLEX PLUG LOCATIONS.

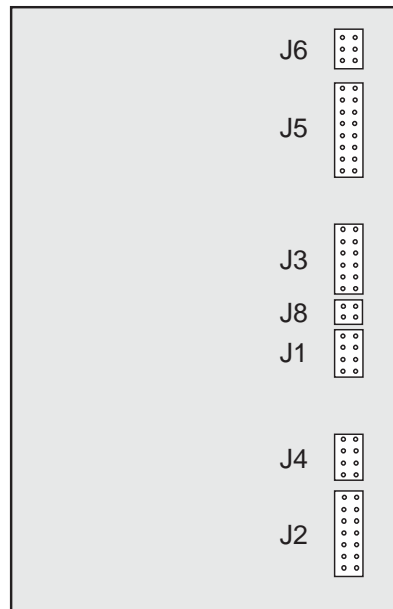

REMOVAL AND REPLACEMENT PROCEDURE

1. Disconnect main input power the machine.
2. Open the side panels and remove the tool tray using a 5/16 in. nutdriver.
3. Disconnect all wiring harness plugs and Molex plugs connected to the control board. See Figure F.10.

CONTROL PC BOARD REMOVAL AND REPLACEMENT (continued)

FIGURE F.11 — CONTROL BOARD MOUNTING.

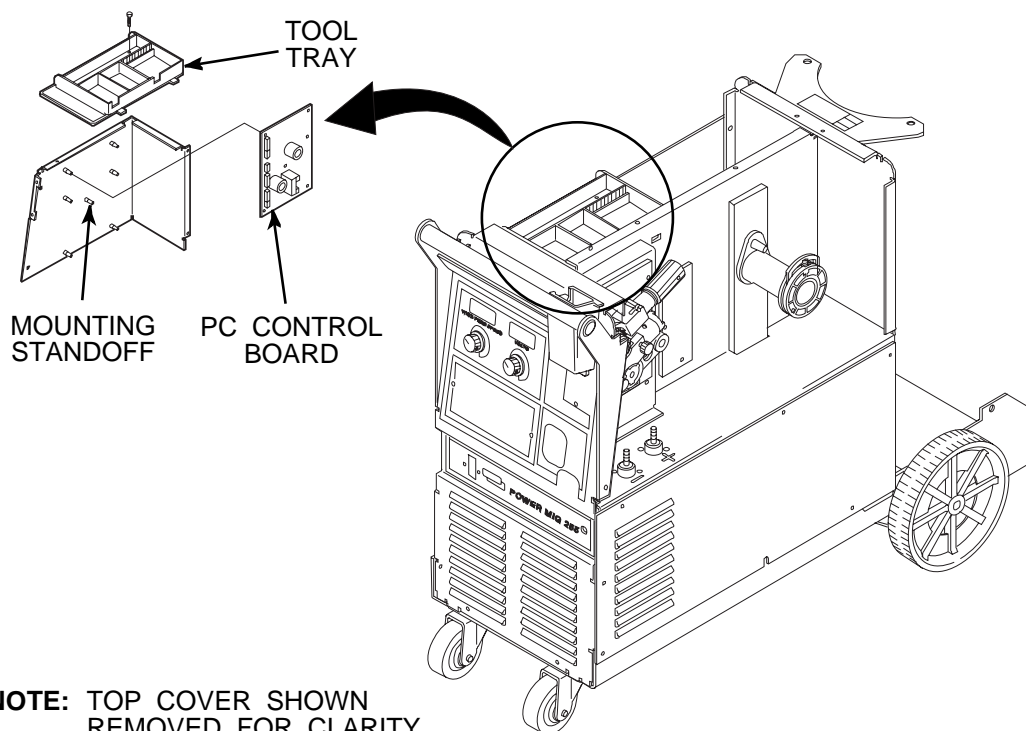

NOTE: TOP COVER SHOWN REMOVED FOR CLARITY.

4. Ensure a static electricity grounding strap is used before handling the control PC boards.
5. Carefully remove the control PC board from the mounting standoffs.
6. Lift the control PC board straight up and out from the machine.
7. When re-installing the control PC board carefully secure board to mounting standoffs.
8. Install all plug connectors previously removed from the control PC board.
9. Install the tool tray and close the side panels.

POWER MIG 255C



Return to Section TOC
Return to Master TOC
Return to Section TOC
Return to Master TOC
Return to Section TOC
Return to Master TOC
Return to Section TOC
Return to Master TOC

POWER MIG 255C



WIRE DRIVE ASSEMBLY REMOVAL AND REPLACEMENT**⚠ WARNING**

Service and repair should only be performed by Lincoln Electric factory trained personnel. Unauthorized repairs performed on this equipment may result in danger to the technician or machine operator and will invalidate your factory warranty. For your safety and to avoid electrical shock, please observe all safety notes and precautions detailed throughout this manual.

If for any reason you do not understand the test procedures or are unable to perform the test/repairs safely, contact the Lincoln Electric service department for technical troubleshooting assistance before you proceed. Call 1-888-935-3877.

DESCRIPTION

The procedure will aid the technician in the removal and replacement of the wire drive assembly.

MATERIALS NEEDED

Large slot head screwdriver
5/16 in. Nutdriver
Small slot head screwdriver
3/4 in. Open end wrench
7/16 in. Nutdriver

POWER MIG 255C

WIRE DRIVE ASSEMBLY REMOVAL AND REPLACEMENT (continued)

FIGURE F.12 — WIRE DRIVE ASSEMBLY REMOVAL

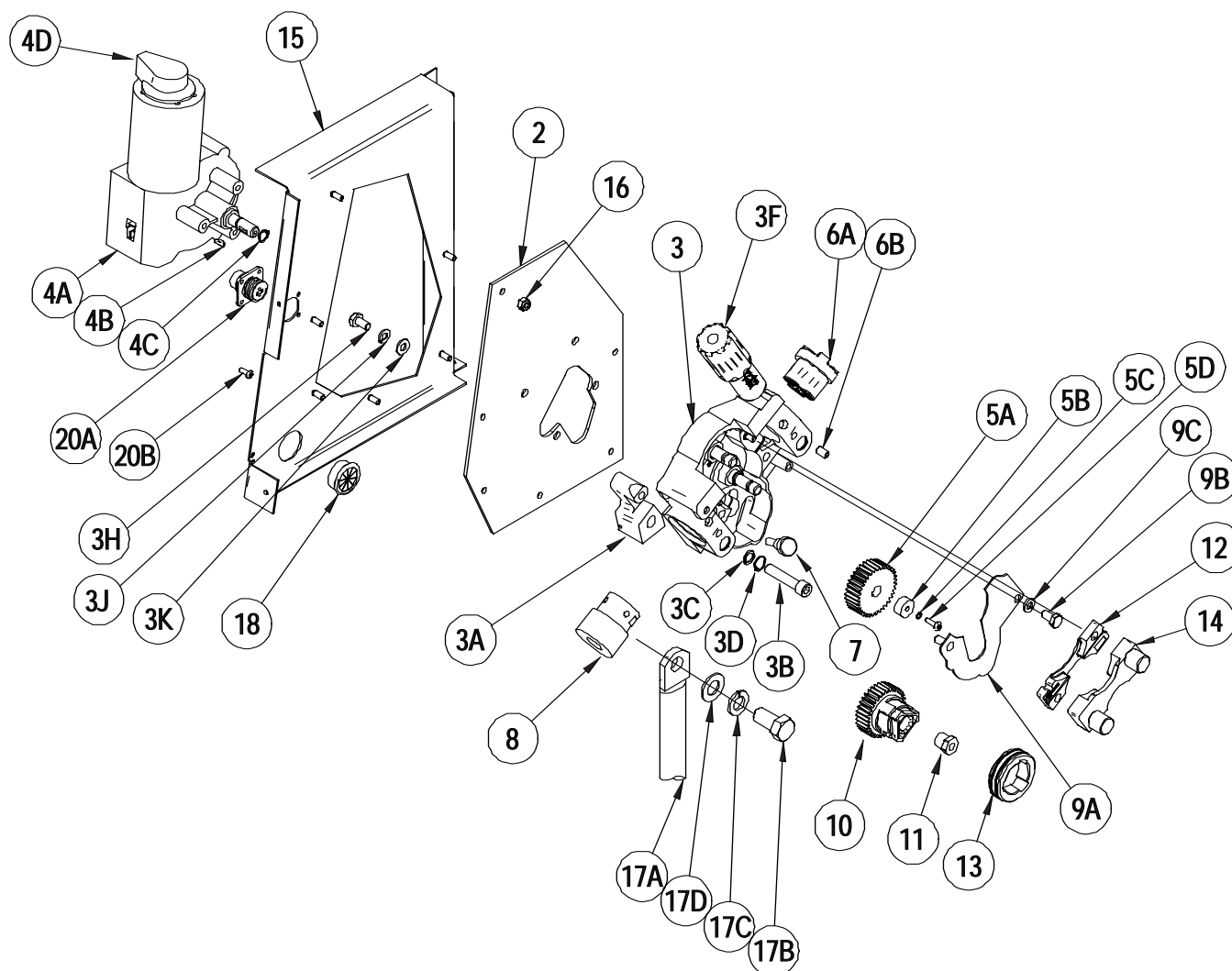

Wire Drive Final Assembly, Includes:

Wire Drive Assembly, Includes:

2 Gearbox Mounting Panel

3 Feedplate Assembly, Includes:

3A Connection Bar

3B Socket Head Cap Screw

3C Plain Washer

3D Retaining Ring

3E Idle Arm (Not Shown)

3F Adjustment Arm Assembly

3G Roll Pin (Not Shown)

3H 1/4-20 x .50 HHCS

3J Lock Washer

3K Plain Washer

4A Motor Gearbox Assembly, Includes:

4B Woodruff Key

4C Snap Ring

4D Tach Sensor

4E Ring Magnet (Not Shown)

4F Lock Washer (Not Shown)

4G Phillips Pan Head Screw (Not Shown)

5A Drive Gear

5B Collar

5C Lock Washer

5D Metric Screw

6A Ball Housing

6B Set Screw

7 Knurled Knob

8 Gun Adapter Assembly

9A Feedplate Cover

9B 1/4-20 x .50 HHCS

9C Lock Washer

10 Drive Roll Shaft Assembly

11 Drive Hub Retainer

12 Inner Wire Guide (.035/.045)

13 Drive Roll (.035/.045)

14 Outer Guide Assembly

15 Wire Drive Compartment

16 #10-24 HLN - Nylon Insert

17A Lead

17B 1/2-13x1.00 HHCS

17C Lock Washer

17D Plain Washer

18 Grommet

19 Decal (Not Shown)

20A Trigger Lead Assembly

20B Self Tapping Screw (Not Shown)

21 Decal (Not Shown)

POWER MIG 255C

WIRE DRIVE ASSEMBLY REMOVAL AND REPLACEMENT (*continued*)

PROCEDURE

1. Disconnect main input power to the machine.
2. Remove the wire gun and wire.
3. Lift the wire drive door to gain access to the wire drive assembly.
4. Lift the tool tray door to allow access to the tool tray.
5. Use a 5/16 in. nutdriver and remove the tool tray to gain access to the motor/gearbox assembly.
6. Disconnect the wire connectors J13 and J12 to the motor/gearbox assembly. See Wiring Diagram.
7. Use a 3/4 in. wrench and remove the flange nut and positive lead from the wire drive assembly. See **Figure F.12**.
8. Use pliers to remove the hose clamp and flex hose from the wire drive assembly.
9. Remove the outer guide assembly from the wire drive assembly by loosening the thumb screws until the outer guide can be removed.
10. Rotate the adjustment arm assembly counterclockwise to release the tension on the idle arm.
11. Swing the idle arm up and away from the wire drive assembly.
12. Use a screwdriver and remove the round head screw, lock washer, and flat washer securing the molded drive roll shaft assembly to the wire drive assembly.
13. Remove the molded drive roll shaft assembly and the rest of the outer guide assembly from the wire drive assembly.
14. Use a screwdriver and remove the pan head screws and lock washers securing the motor/gearbox assembly to the wire drive assembly.
15. Grasp the motor/gearbox assembly and wiggle the motor/gearbox assembly gently back and forth until it separates from the wire drive assembly.
16. Use a 7/16 in. nutdriver to remove the hex head cap screws, lock washers, and flat washers securing the wire drive assembly to the wire drive compartment.
17. Remove the wire drive assembly from the wire drive compartment.
18. Reassemble the wire drive assembly in the reverse order.

Return to Section TOC
Return to Master TOC
Return to Section TOC
Return to Master TOC
Return to Section TOC
Return to Master TOC
Return to Section TOC
Return to Master TOC

POWER MIG 255C



SCR OUTPUT RECTIFIER REMOVAL AND REPLACEMENT

⚠ WARNING

Service and repair should only be performed by Lincoln Electric factory trained personnel. Unauthorized repairs performed on this equipment may result in danger to the technician or machine operator and will invalidate your factory warranty. For your safety and to avoid electrical shock, please observe all safety notes and precautions detailed throughout this manual.

If for any reason you do not understand the test procedures or are unable to perform the test/repairs safely, contact the Lincoln Electric service department for technical troubleshooting assistance before you proceed. Call 1-888-935-3877.

DESCRIPTION

The procedure will aid the technician in the removal and replacement of the SCR assembly.

MATERIALS NEEDED

- 1/2 in. Open end wrench
- 1/2 in. Socket wrench, universal tool, and extension
- 3/8 in. Nutdriver
- 3/8 in. Open end wrench

SCR OUTPUT RECTIFIER REMOVAL AND REPLACEMENT *(continued)*

PROCEDURE

1. Remove the case side panels using a 3/8 in. nutdriver.
2. Disconnect lead #208S and transformer lead X1 from the heat sink on the left side of the machine using a 1/2 in. socket wrench. See Figure F.13.
 - a. Thin lead is always on the outboard side of the connection.
3. Disconnect lead #204 and heavy aluminum choke lead from the middle heat sink with a 1/2 in. socket wrench and 1/2 in. open end wrench. See Figure F.14.
4. Remove the diode lead from the negative capacitor band buss bar on the right side of the machine using a 1/2 in. socket and 3/8 in. open end wrench.

FIGURE F.13 — LEFT HEAT SINK LEAD DISCONNECTION.

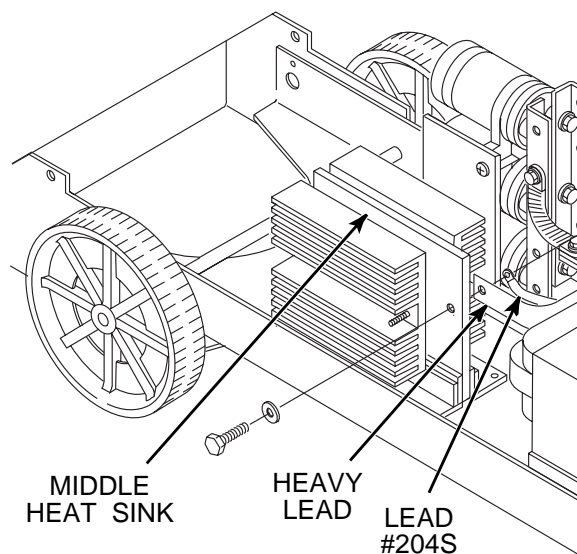
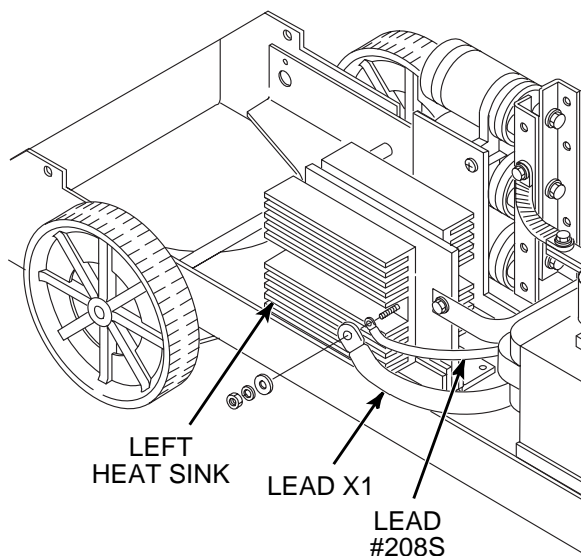
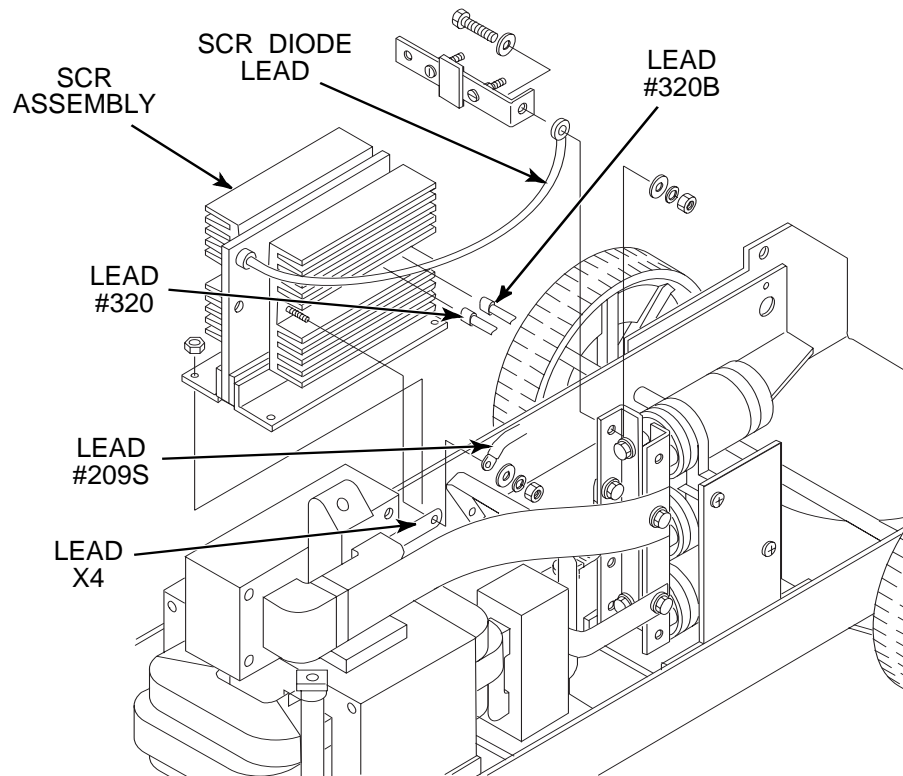

FIGURE F.14 — MIDDLE HEAT SINK LEAD DISCONNECTION.

SCR OUTPUT RECTIFIER REMOVAL AND REPLACEMENT *(continued)*

FIGURE F.15 — RIGHT HEAT SINK LEAD DISCONNECTION.



5. Remove lead #209S and transformer lead X4 from the right side heat sink using a 1/2 in. socket wrench and 1/2 in. open end wrench. See Figure F.15.
 6. Unplug the SCR gate leads G1 and G2 (see wire markers and wiring diagram).
 7. Remove the four nuts holding the SCR assembly to the floor of the machine using a 3/8 in. nutdriver.
 8. Clear the leads and carefully remove the SCR rectifier assembly.
- NOTE:** When installing the SCR rectifier assembly, apply a thin coating of Dow Corning #340 compound to the electrical connections.
9. Unplug leads 320 and 320B from the SCR heat sink thermostat on the right side at the SCR assembly.
 10. Reassemble the SCR assembly in the reverse order.

Return to Section TOC
Return to Master TOC
Return to Section TOC
Return to Master TOC
Return to Section TOC
Return to Master TOC
Return to Section TOC
Return to Master TOC

POWER MIG 255C



CAPACITOR BANK REMOVAL AND REPLACEMENT

⚠ WARNING

Service and repair should only be performed by Lincoln Electric factory trained personnel. Unauthorized repairs performed on this equipment may result in danger to the technician or machine operator and will invalidate your factory warranty. For your safety and to avoid electrical shock, please observe all safety notes and precautions detailed throughout this manual.

If for any reason you do not understand the test procedures or are unable to perform the test/repairs safely, contact the Lincoln Electric service department for technical troubleshooting assistance before you proceed. Call 1-888-935-3877.

⚠ WARNING

The liquid electrode in the capacitors is toxic. Do not touch the capacitors with any part of your body.

DESCRIPTION

The procedure will aid the technician in the removal and replacement of the capacitor bank.

MATERIALS NEEDED

5/16 in. Nutdriver
3/8 in. Nutdriver
1/2 in. Open end wrench
3/8 in. Open end wrench
Wiring diagram

CAPACITOR BANK REMOVAL AND REPLACEMENT (continued)

FIGURE F.16 — LOCATION OF CAPACITOR BANK REMOVAL AND REPLACEMENT COMPONENTS.

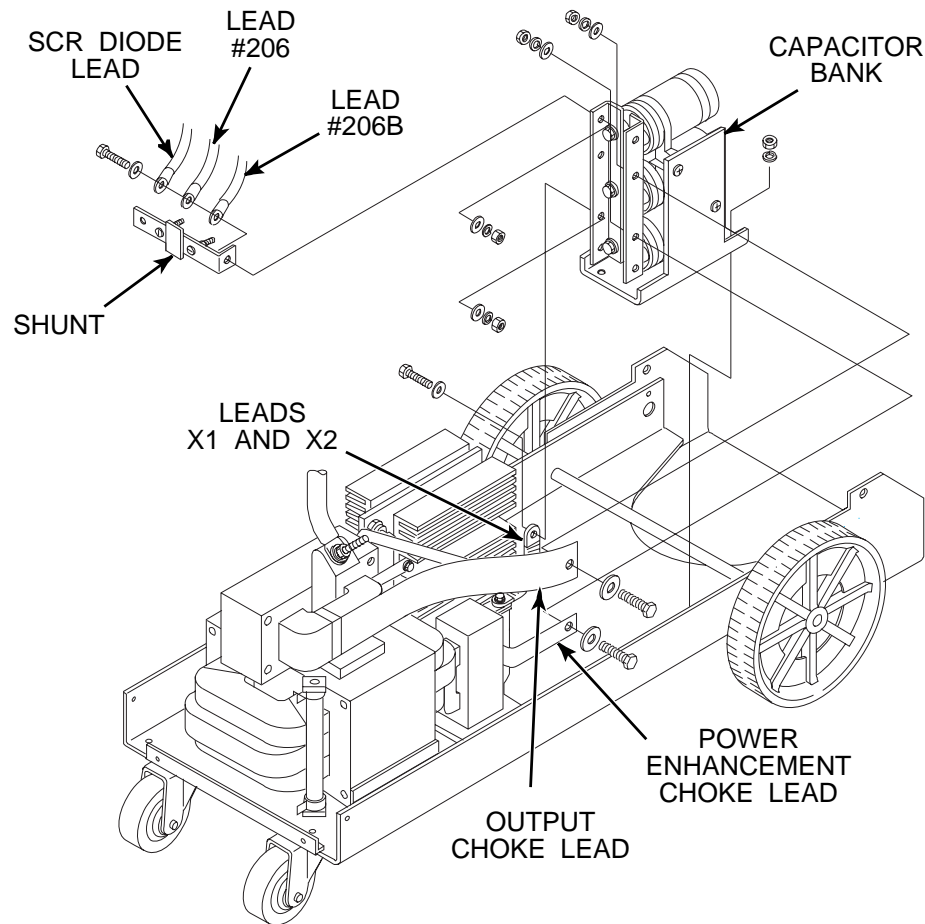

PROCEDURE

See Figure F.16 for location of capacitor bank removal and replacement components.

1. Disconnect main input power to the machine.
2. Remove the case side panels using a 3/8 in. nutdriver.
3. Test that the capacitors are discharged using a volt ohmmeter. Polarity must be observed.
4. Remove the two transformer secondary leads X2 and X3 (braided copper strap) from the negative capacitor bank buss bar using two 1/2 in. open end wrenches.
5. Remove the shunt, leads 206, 206B, and the SCR diode lead from the negative capacitor bank buss bar using a 1/2 in. open end wrench.
6. Remove the choke lead and lead 204B from the positive capacitor bank buss bar using two 1/2 in. open end wrenches.
7. Remove the power factor enhancement choke lead from the positive capacitor buss bar using two 1/2 in. open end wrenches.
8. Remove the three nuts holding the capacitor bank to the floor of the machine using a 3/8 in. nut driver.
9. Clear the leads and carefully remove the capacitor bank assembly from the machine.
10. Reassemble the capacitor bank in the reverse order.

POWER MIG 255C



MAIN TRANSFORMER AND OUTPUT CHOKE REMOVAL AND REPLACEMENT

WARNING

Service and repair should only be performed by Lincoln Electric factory trained personnel. Unauthorized repairs performed on this equipment may result in danger to the technician or machine operator and will invalidate your factory warranty. For your safety and to avoid electrical shock, please observe all safety notes and precautions detailed throughout this manual.

If for any reason you do not understand the test procedures or are unable to perform the test/repairs safely, contact the Lincoln Electric service department for technical troubleshooting assistance before you proceed. Call 1-888-935-3877.

DESCRIPTION

The procedure will aid the technician in the removal and replacement of the main transformer and choke assembly.

MATERIALS NEEDED

5/16 in. Nut Driver
1/2 in. Open end wrench
3/8 in. Open end wrench
1/2 in. Socket wrench, extender, universal adapter
Wire cutters
Phillips head screwdriver

POWER MIG 255C



MAIN TRANSFORMER AND OUTPUT CHOKE REMOVAL AND REPLACEMENT *(continued)*

FIGURE F.17 — MAIN TRANSFORMER REMOVAL.

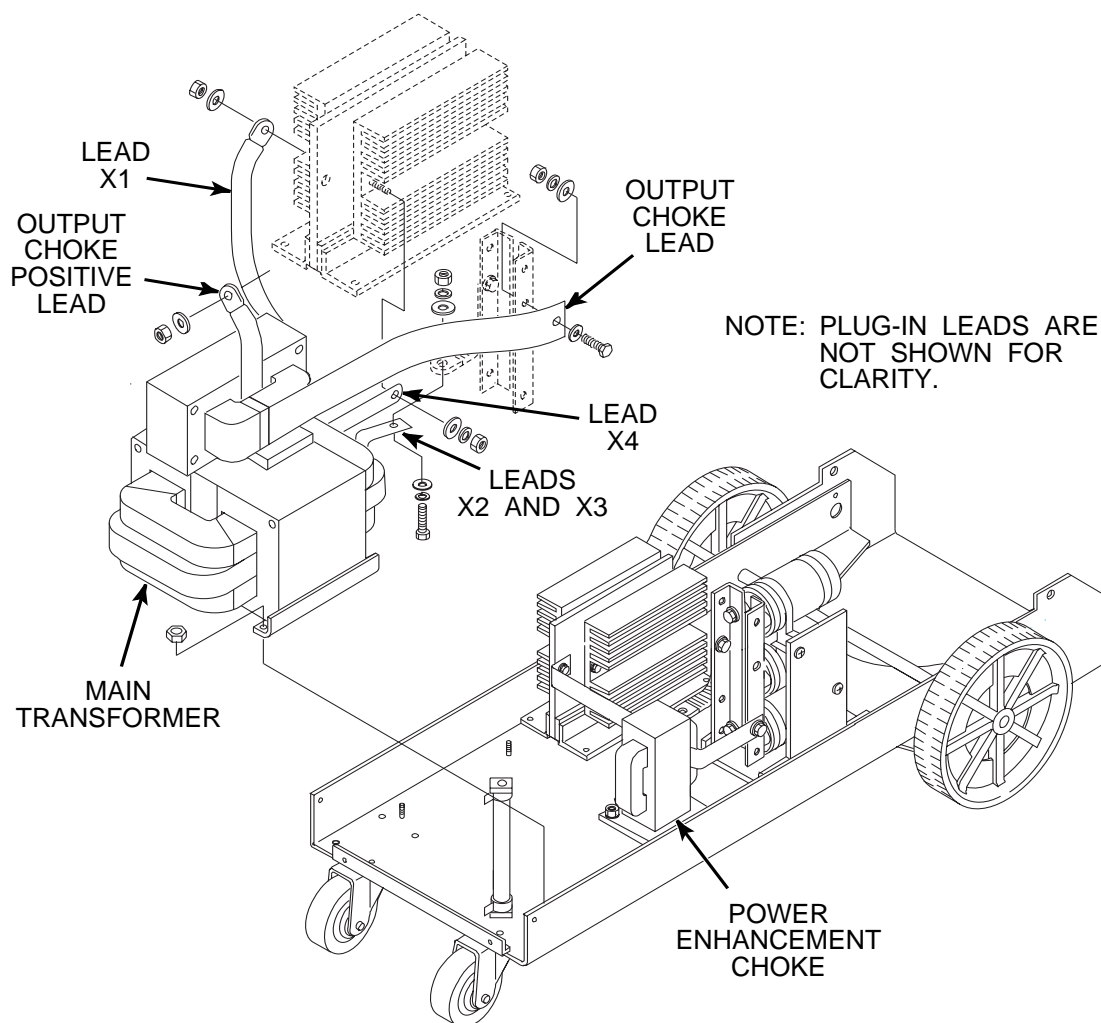

PROCEDURE

1. Disconnect main input power to the machine.
2. Remove the case side panels using a 3/8 in. nutdriver.
3. Test that the capacitors are discharged using a volt ohmmeter. Polarity must be observed.
4. Remove lead X1 from the left side SCR heat sink assembly using a 1/2 in. socket wrench, extender and universal adapter. See Figure F.17.
5. Remove lead X4 from the right side heat sink assembly using a 1/2 in. socket wrench, extender and universal adapter.
6. Remove the two transformer secondary leads X2 and X3 (braided copper strap) from the negative capacitor bank buss bar using two 1/2 in. open end wrenches.
7. Disconnect and label all transformer leads from the reconnect panel using a 3/8 in. open end wrench.
8. Disconnect and label all leads from the input power switch.
9. Remove the power switch.
10. Disconnect thermostat leads #320 and #320B from the SCR Rectifier.

POWER MIG 255C



**MAIN TRANSFORMER AND OUTPUT CHOKE
REMOVAL AND REPLACEMENT** *(continued)*

11. Unplug and label leads X5, X6, X7, X8, and X9. These leads have connectors near the transformer which can be disconnected.
12. Disconnect the output choke lead from the positive capacitor bank buss using two 1/2 in. open end wrenches.
13. Remove the other output choke lead from the positive output terminal using a 1/2 in. wrench.
13. Remove all cable ties, wire mounts, and any harness type that could get in the way during transformer removal using wire cutters and screw driver.
14. Remove the four nuts and washers mounting the transformer to the floor of the machine using a 1/2 in. wrench.
15. Carefully remove the main transformer and choke assembly.
16. Reassemble the main transformer and choke assembly in the reverse order.

Return to Section TOC

Return to Master TOC

Return to Section TOC

Return to Master TOC

Return to Section TOC

Return to Master TOC

Return to Section TOC

Return to Master TOC

POWER MIG 255C



Return to Section TOC
Return to Master TOC
Return to Section TOC
Return to Master TOC
Return to Section TOC
Return to Master TOC
Return to Section TOC
Return to Master TOC

POWER MIG 255C



FAN MOTOR ASSEMBLY REMOVAL AND REPLACEMENT

⚠ WARNING

Service and repair should only be performed by Lincoln Electric factory trained personnel. Unauthorized repairs performed on this equipment may result in danger to the technician or machine operator and will invalidate your factory warranty. For your safety and to avoid electrical shock, please observe all safety notes and precautions detailed throughout this manual.

If for any reason you do not understand the test procedures or are unable to perform the test/repairs safely, contact the Lincoln Electric service department for technical troubleshooting assistance before you proceed. Call 1-888-935-3877.

DESCRIPTION

The procedure will aid the technician in the removal and replacement of the fan motor assembly.

MATERIALS NEEDED

3/8 in. Nutdriver
11/32 in. Open end wrench
Slot head screwdriver

Return to Section TOC
Return to Master TOCReturn to Section TOC
Return to Master TOCReturn to Section TOC
Return to Master TOCReturn to Section TOC
Return to Master TOC

POWER MIG 255C



FAN MOTOR ASSEMBLY REMOVAL AND REPLACEMENT *(continued)*

FIGURE F.18 — FAN MOTOR ASSEMBLY REMOVAL.

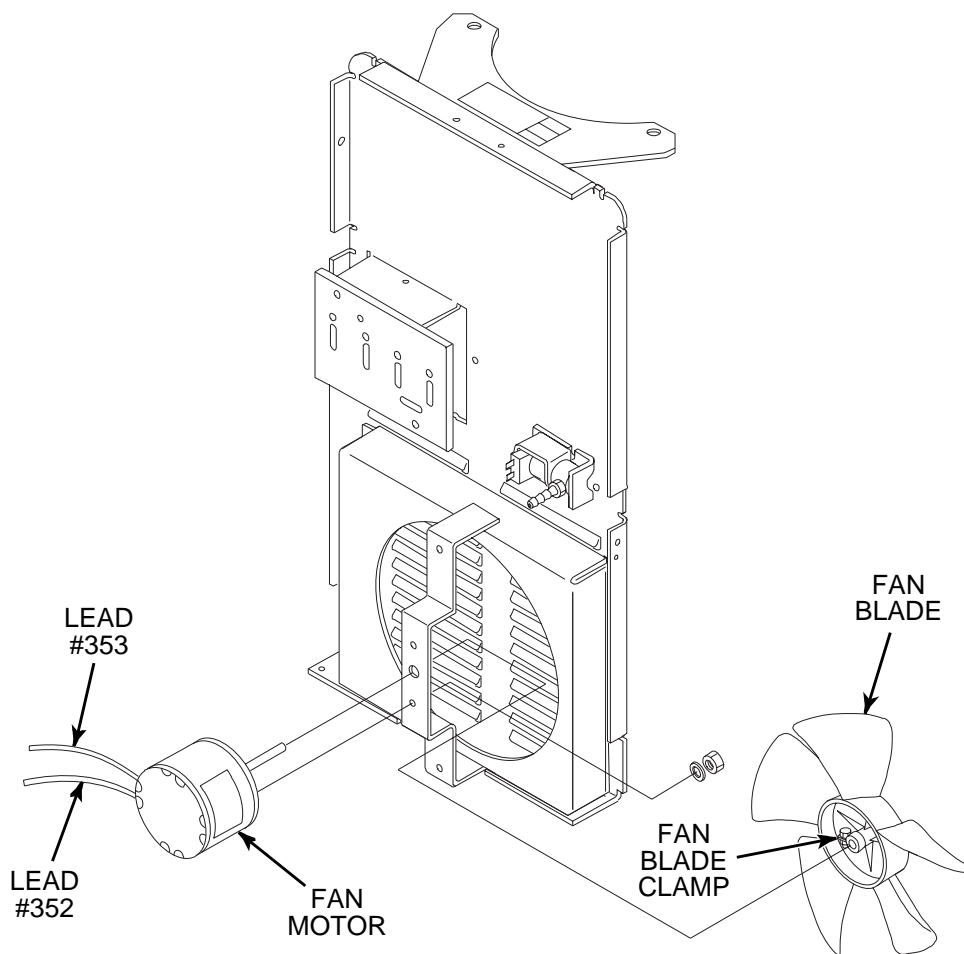
**PROCEDURE**

1. Disconnect main input power to the machine.
1. Remove the case side panels using a 3/8 in. nutdriver.
2. Disconnect the fan motor leads #352 and #352. See Figure F.18.
3. Remove the fan blade. Note the position of the fan on the shaft for reassembly.
 - a. Use a screwdriver to loosen the fan blade clamp.
 - b. Slide the fan blade off the motor shaft.
4. Remove the fan motor.
 - a. Loosen and remove the two nuts and lock washers from the motor mounting bracket using a 11/32 in. open end wrench.
 - b. When the motor is free from the mounting bracket, slide the motor from the POWER MIG unit.
5. Install the replacement motor in the reverse order of removal.
6. Install the fan blade and tighten the fan blade clamp. Ensure the fan is in the same position on the shaft as it was prior to removal.
 - a. Spin the fan to be sure it is free to rotate.
7. Reassemble the remaining components in reverse order of removal.

POWER MIG 255C



RETEST AFTER REPAIR**INPUT IDLE AMPS AND WATTS**

Input Volts/Hertz	Maximum Idle Amps	Maximum Idle Watts
230/60	7.0	400

OPEN CIRCUIT VOLTAGE

35-40 VDC

WIRE SPEED RANGE

50 - 700 IPM (1.27 - 17.8 m/minute)

Return to Section TOC

Return to Section TOC

Return to Section TOC

Return to Section TOC

Return to Master TOC

Return to Master TOC

Return to Master TOC

Return to Master TOC

POWER MIG 255C



NOTES

Return to Section TOC

Return to Section TOC

Return to Section TOC

Return to Section TOC

Return to Master TOC

Return to Master TOC

Return to Master TOC

Return to Master TOC

POWER MIG 255C



TABLE OF CONTENTS - ELECTRICAL DIAGRAMS SECTION -

Electrical DiagramsSection G

Wiring Diagram - Entire Machine - Code 11192 - (L12464)G-2

Wiring Diagram - Entire Machine - Code 11218 - (L12506)G-3

Schematic - Entire Machine - (G4752)G-4

Schematic - Control PC Board - (G4823-2D1 Sheet 1)G-5

Schematic - Control PC Board - (G4823-2D1 Sheet 2)G-6

Schematic - Control PC Board - (G4823-2D1 Sheet 3)G-7

PC Board Assembly - Control - (G4824-2D1)G-8

Schematic - Display PC Board - (L10951)G-9

PC Board Assembly - Display - (L10952-1)G-10

Return to Master TOC

Return to Master TOC

Return to Master TOC

Return to Master TOC

POWER MIG 255C



POWER MIG 255C (208/230V)

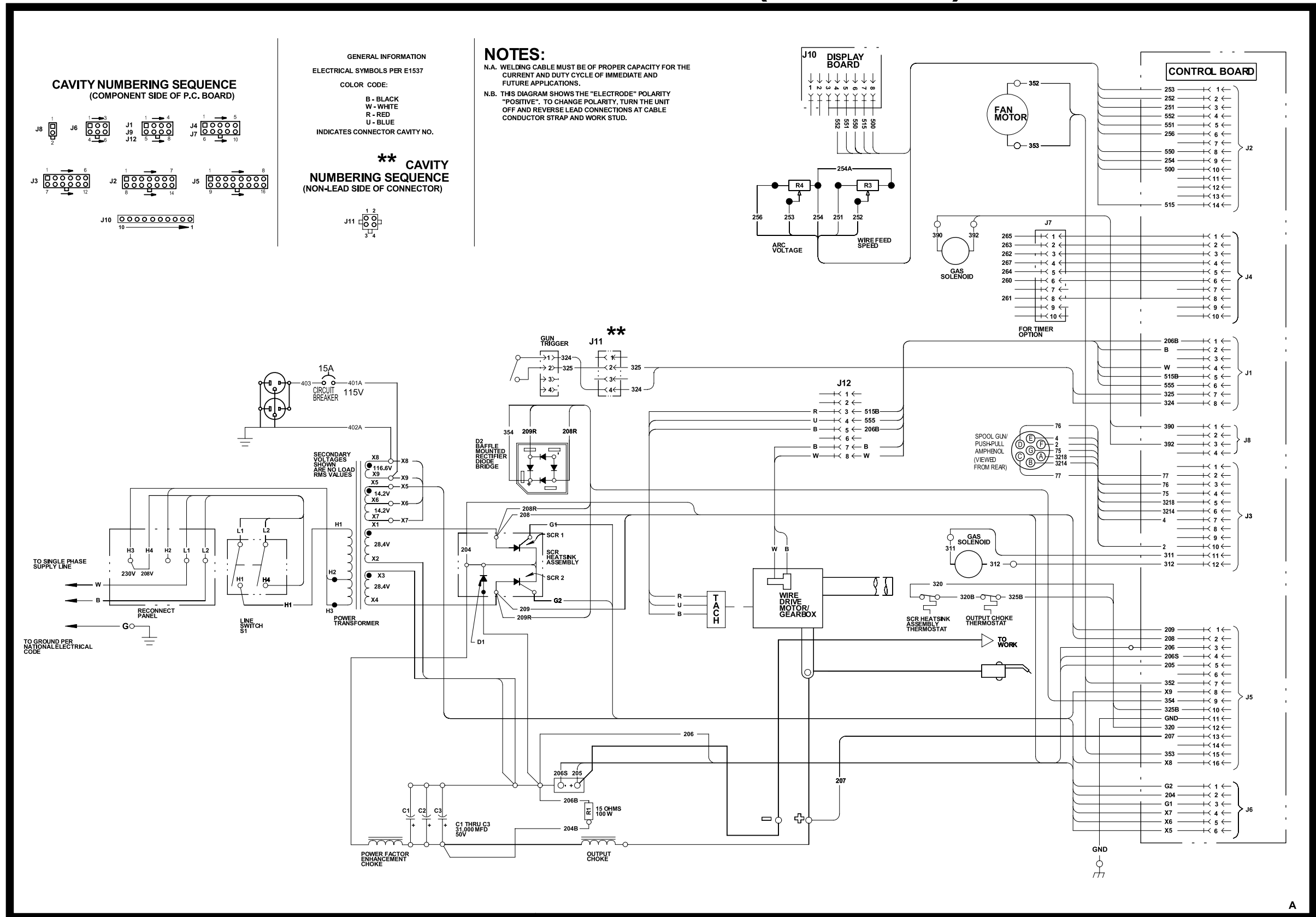

CAVITY NUMBERING SEQUENCE (COMPONENT SIDE OF P.C. BOARD)

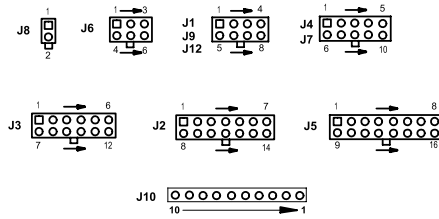

GENERAL INFORMATION ELECTRICAL SYMBOLS PER E1537

COLOR CODE:
 B - BLACK
 W - WHITE
 R - RED
 U - BLUE
 INDICATES CONNECTOR CAVITY NO.

** CAVITY NUMBERING SEQUENCE (NON-LEAD SIDE OF CONNECTOR)



NOTES:

N.A. WELDING CABLE MUST BE OF PROPER CAPACITY FOR THE CURRENT AND DUTY CYCLE OF IMMEDIATE AND FUTURE APPLICATIONS.

N.B. THIS DIAGRAM SHOWS THE "ELECTRODE" POLARITY "POSITIVE". TO CHANGE POLARITY, TURN THE UNIT OFF AND REVERSE LEAD CONNECTIONS AT CABLE CONDUCTOR STRAP AND WORK STUD.

Return to Section TOC
Return to Section TOC
Return to Section TOC
Return to Section TOC
Return to Section TOC
Return to Section TOC
Return to Section TOC

NOTE: This diagram is for reference only. It may not be accurate for all machines covered by this manual. The wiring diagram specific to your code is pasted inside one of the enclosure panels of your machine.

SCHEMATIC - ENTIRE MACHINE - (G4752)

Return to Section TOC
Return to Master TOC

Return to Section TOC
Return to Master TOC

Return to Section TOC
Return to Master TOC

Return to Section TOC
Return to Master TOC

CAVITY NUMBERING SEQUENCE (COMPONENT SIDE OF P.C. BOARD)

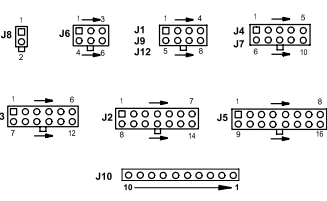

GENERAL INFORMATION
ELECTRICAL SYMBOLS PER E1537
COLOR CODE:
B - BLACK
W - WHITE
R - RED
U - BLUE
INDICATES CONNECTOR CAVITY NO.

** CAVITY NUMBERING SEQUENCE (NON-LEAD SIDE OF CONNECTOR)

NOTES:
N.A. WELDING CABLE MUST BE OF PROPER CAPACITY FOR THE CURRENT AND DUTY CYCLE OF IMMEDIATE AND FUTURE APPLICATIONS.
N.B. THIS DIAGRAM SHOWS THE "ELECTRODE" POLARITY "POSITIVE". TO CHANGE POLARITY, TURN THE UNIT OFF AND REVERSE LEAD CONNECTIONS AT CABLE CONDUCTOR STRAP AND WORK STUD.
N.C. THIS MACHINE IS WIRED TO USE A PRINCE XL SPOOL GUN DIRECTLY. A K245-1 ADAPTER IS NEEDED TO USE A MAGNUM SPOOL GUN.

POWER MIG 255C
CODE 11192, 11218

OUTPUT RATING
The POWER MIG 255C is rated at 250 amps @ 26 volts, at a 40% duty cycle based on a ten minute cycle time. It is capable of higher duty cycles at lower output currents and capable of up to 300 Amps at lower duty cycles.

PROCEDURES
Weld procedures are listed on the hinged flip up door of the machine, or consult Procedure Chart G3681.

ERRORS DISPLAYED
"Too HOT" - Thermostat is open; allow machine to cool.
"Too HT" - Input voltage is too high; verify reconnect or obtain lower input voltage.
"Too Lo" - Input voltage is too low; verify reconnect or obtain higher input voltage.

THIS SECTION APPEARS ON 208V/230V MACHINE ONLY

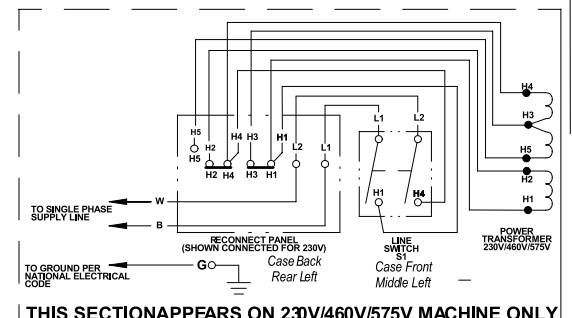
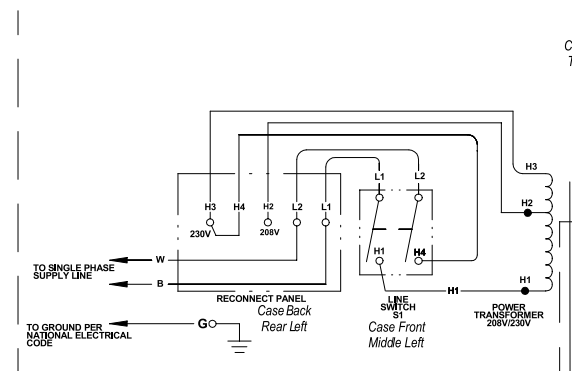

LIMITATION
The PowerMIG 255C WILL NOT operate satisfactorily if powered with a portable or in-plant generating system, including engine welders

Receptacle is intended for non-complex loads (i.e. lights, drills, saws, grinders, tool battery chargers).

SECONDARY VOLTAGES SHOWN ARE W/LOAD RMS VALUES

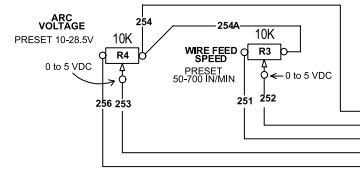

OPTIONAL TIMER BOARD FEATURES
Automatically SENSES if board is present.
Adjustable SPOT TIME from 0 to 5 sec.
Adjustable BURNBACK TIME from 0 to 250 msec.
Adjustable RUN-IN speed from 50 to 250 IPM
Convenient 4 STEP TRIGGER INTERLOCK

J11 **
Located inside control box

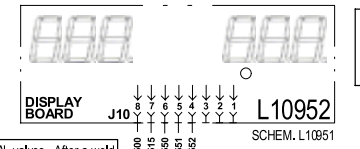

Displays show SET and ACTUAL values. After a weld actual values are "held" for 5 seconds (with LED flashes) before returning to set values. When using a Prince XL spool gun, display will show Volts and WFS.

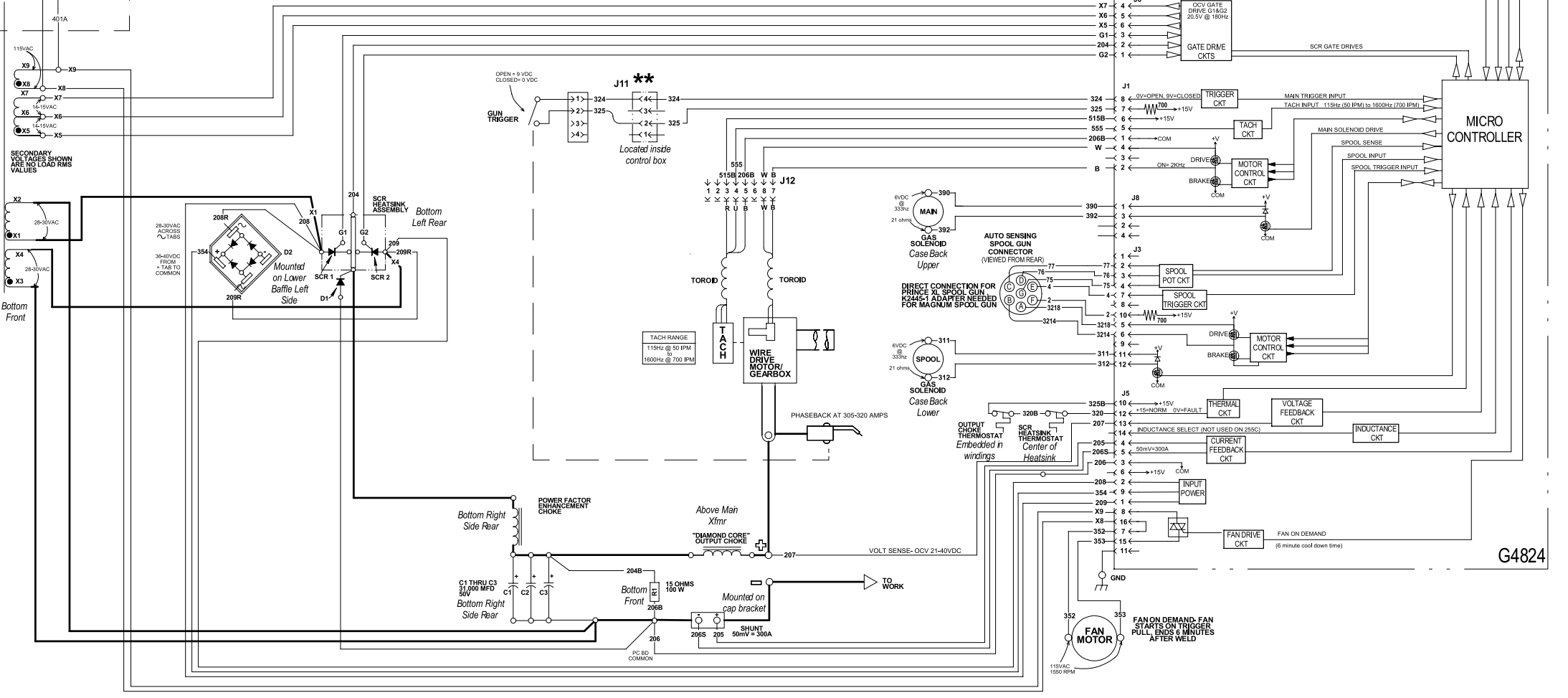

G4824

NOTE: This diagram is for reference only. It may not be accurate for all machines covered by this manual.

SCHEMATIC - CONTROL PC BOARD - (G4823-2D1 SHEET 1)

Return to Section TOC
Return to Section TOC
Return to Section TOC
Return to Section TOC
Return to Section TOC
Return to Section TOC
Return to Section TOC
Return to Section TOC

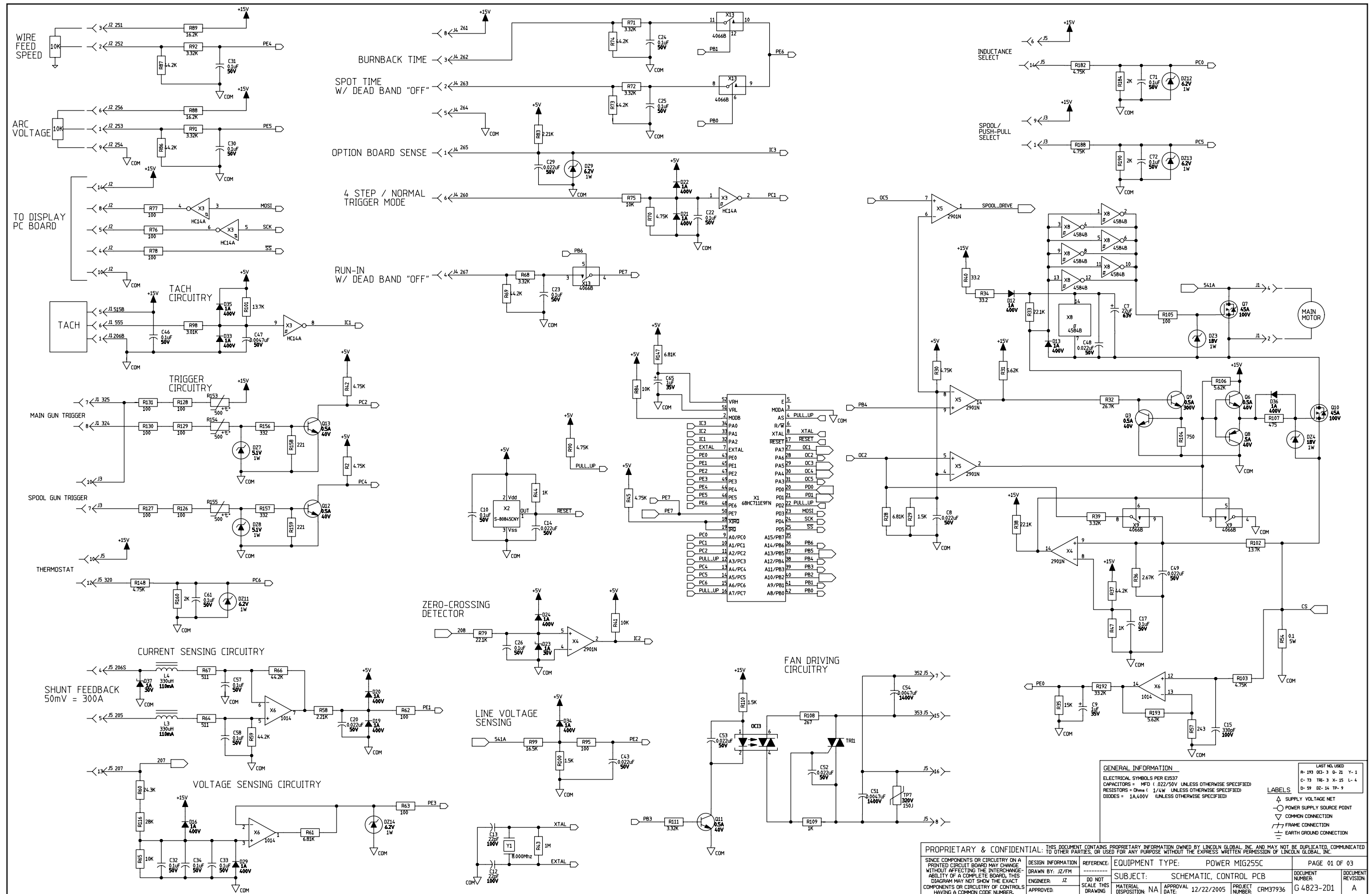

GENERAL INFORMATION

ELECTRICAL SYMBOLS PER IEC 60617
 CAPACITORS = MFD (0.022/50V UNLESS OTHERWISE SPECIFIED)
 RESISTORS = Ohms (1/4W UNLESS OTHERWISE SPECIFIED)
 DIODES = 1A,400V UNLESS OTHERWISE SPECIFIED

LABELS

- ▲ SUPPLY VOLTAGE NET
- POWER SUPPLY SOURCE POINT
- ▽ COMMON CONNECTION
- FRAME CONNECTION
- ⊥ EARTH GROUND CONNECTION

PROPRIETARY & CONFIDENTIAL: THIS DOCUMENT CONTAINS PROPRIETARY INFORMATION OWNED BY LINCOLN GLOBAL, INC. AND MAY NOT BE DUPLICATED, COMMUNICATED TO OTHER PARTIES, OR USED FOR ANY PURPOSE WITHOUT THE EXPRESS WRITTEN PERMISSION OF LINCOLN GLOBAL, INC.

SINCE COMPONENTS OR CIRCUITRY ON A PRINTED CIRCUIT BOARD MAY CHANGE WITHOUT AFFECTING THE INTERCHANGEABILITY OF A COMPLETE BOARD, THIS DIAGRAM MAY NOT SHOW THE EXACT COMPONENTS OR CIRCUITRY OF CONTROLS HAVING A COMMON CODE NUMBER.	DESIGN INFORMATION DRAWN BY: JZ/JM ENGINEER: JZ APPROVED:	REFERENCE: SUBJECT: SCHEMATIC, CONTROL PCB MATERIAL DISPOSITION: NA APPROVAL DATE: 12/22/2005	EQUIPMENT TYPE: POWER MIG255C PAGE 01 OF 03	DOCUMENT NUMBER: G 4823-2D1 REVISION: A
--	--	--	--	--

NOTE: This diagram is for reference only. It may not be accurate for all machines covered by this manual.



SCHEMATIC - CONTROL PC BOARD - (G4823-2D1 SHEET 2)

Return to Section TOC
Return to Section TOC
Return to Section TOC
Return to Section TOC
Return to Section TOC
Return to Section TOC
Return to Section TOC
Return to Section TOC

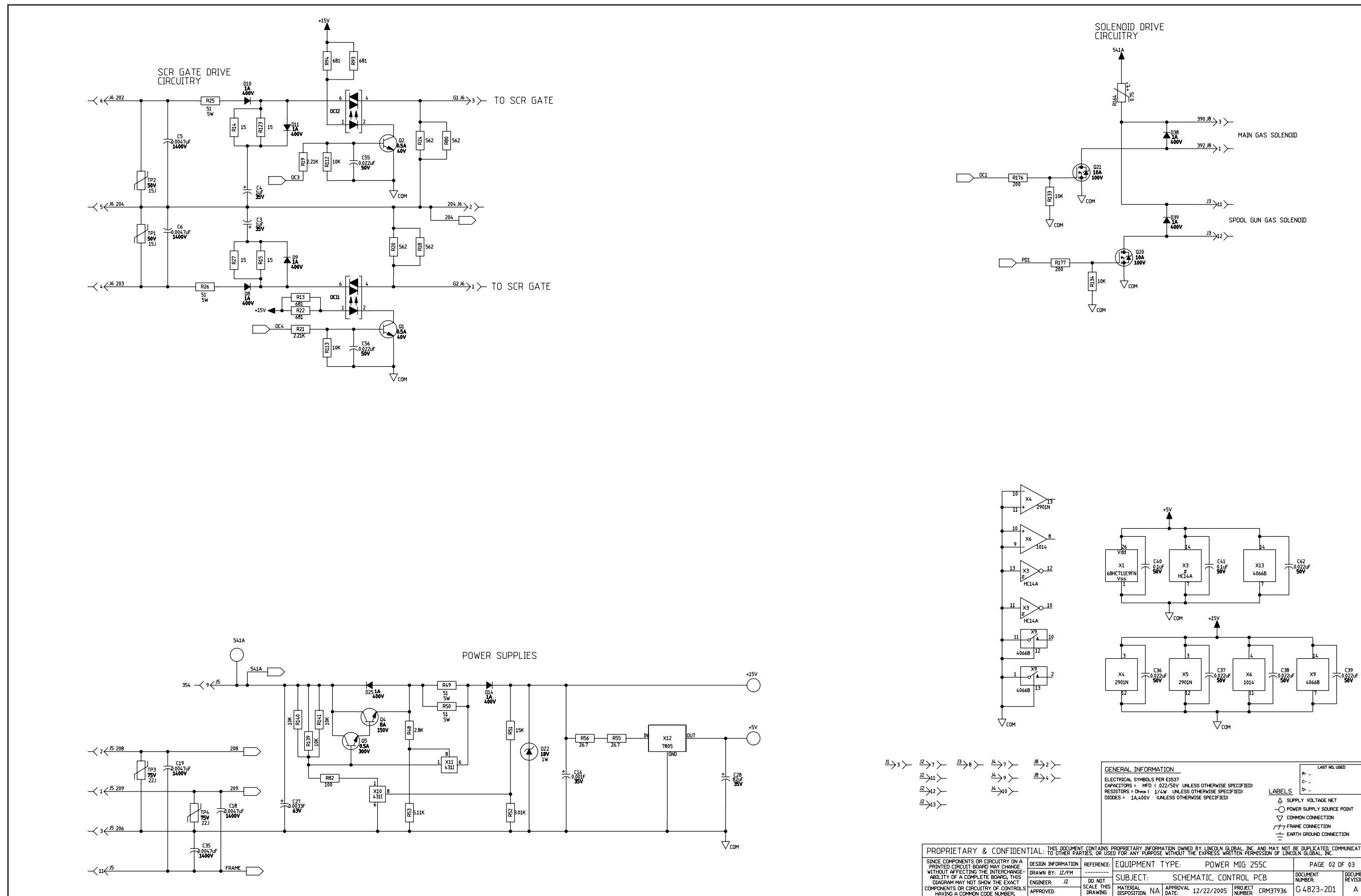

NOTE: This diagram is for reference only. It may not be accurate for all machines covered by this manual.

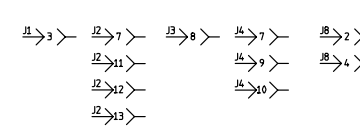

GENERAL INFORMATION		LAST NO. USED	
ELECTRICAL SYMBOLS PER IEEE37		A -	
CAPACITORS = MFD (0.22/50V UNLESS OTHERWISE SPECIFIED)		C -	
RESISTORS = Ohms (1/4W UNLESS OTHERWISE SPECIFIED)		D -	
DIODES = 1A, 400V (UNLESS OTHERWISE SPECIFIED)			
LABELS ▲ SUPPLY VOLTAGE NET ○ POWER SUPPLY SOURCE POINT ▽ COMMON CONNECTION ▬▬▬ FRAME CONNECTION ⊕ EARTH GROUND CONNECTION			

PROPRIETARY & CONFIDENTIAL: THIS DOCUMENT CONTAINS PROPRIETARY INFORMATION OWNED BY LINCOLN GLOBAL, INC. AND MAY NOT BE DUPLICATED, COMMUNICATED TO OTHER PARTIES, OR USED FOR ANY PURPOSE WITHOUT THE EXPRESS WRITTEN PERMISSION OF LINCOLN GLOBAL, INC.			
SINCE COMPONENTS OR CIRCUITRY ON A PRINTED CIRCUIT BOARD MAY CHANGE WITHOUT AFFECTING THE INTERCHANGEABILITY OF A COMPLETE BOARD, THIS DIAGRAM MAY NOT SHOW THE EXACT COMPONENTS OR CIRCUITRY OF CONTROLS HAVING A COMMON CODE NUMBER.	DESIGN INFORMATION DRAWN BY: JZ/FM ENGINEER: JZ APPROVED:	REFERENCE: DO NOT SCALE THIS DRAWING	EQUIPMENT TYPE: POWER MIG 255C SUBJECT: SCHEMATIC, CONTROL PCB MATERIAL DISPOSITION: NA APPROVAL DATE: 12/22/2005 PROJECT NUMBER: CRM37936
			PAGE 02 OF 03 DOCUMENT NUMBER: G4823-2D1 REVISION: A



SCHEMATIC - CONTROL PC BOARD - (G4823-2D1 SHEET 3)

Return to Section TOC
Return to Master TOC

Return to Section TOC
Return to Master TOC

Return to Section TOC
Return to Master TOC

Return to Section TOC
Return to Master TOC

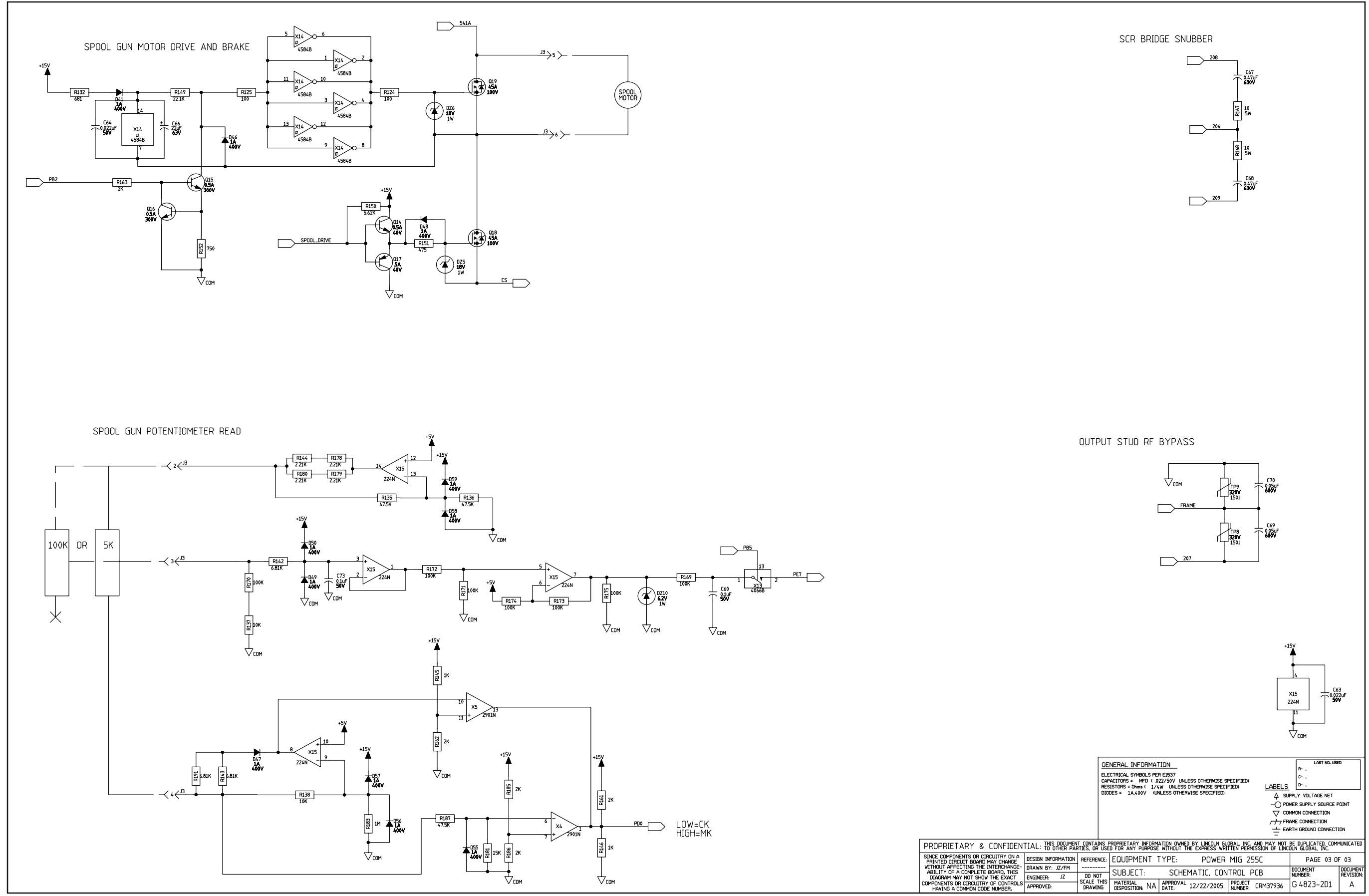

GENERAL INFORMATION

ELECTRICAL SYMBOLS PER E1537
 CAPACITORS = MFD (0.22/50V UNLESS OTHERWISE SPECIFIED)
 RESISTORS = Ohms (1/4W UNLESS OTHERWISE SPECIFIED)
 DIODES = 1A,400V UNLESS OTHERWISE SPECIFIED

LABELS

LAST NO. USED
 R - RESISTOR
 C - CAPACITOR
 D - DIODE

▲ SUPPLY VOLTAGE NET
 ○ POWER SUPPLY SOURCE POINT
 ▽ COMMON CONNECTION
 ▭ FRAME CONNECTION
 ⊕ EARTH GROUND CONNECTION

PROPRIETARY & CONFIDENTIAL: THIS DOCUMENT CONTAINS PROPRIETARY INFORMATION OWNED BY LINCOLN GLOBAL, INC. AND MAY NOT BE DUPLICATED, COMMUNICATED TO OTHER PARTIES, OR USED FOR ANY PURPOSE WITHOUT THE EXPRESS WRITTEN PERMISSION OF LINCOLN GLOBAL, INC.

DESIGN INFORMATION	REFERENCE	EQUIPMENT TYPE:	POWER MIG 255C	PAGE 03 OF 03
DRAWN BY: JZ/JFM	---	SUBJECT:	SCHEMATIC, CONTROL PCB	DOCUMENT NUMBER:
ENGINEER: JZ	DO NOT SCALE THIS DRAWING	MATERIAL DISPOSITION: NA	APPROVAL DATE: 12/22/2005	PROJECT NUMBER: CRM37936
APPROVED:				G 4823-2D1
				DOCUMENT REVISION: A

NOTE: This diagram is for reference only. It may not be accurate for all machines covered by this manual.



PC BOARD ASSEMBLY - CONTROL - (G4824-2D1)

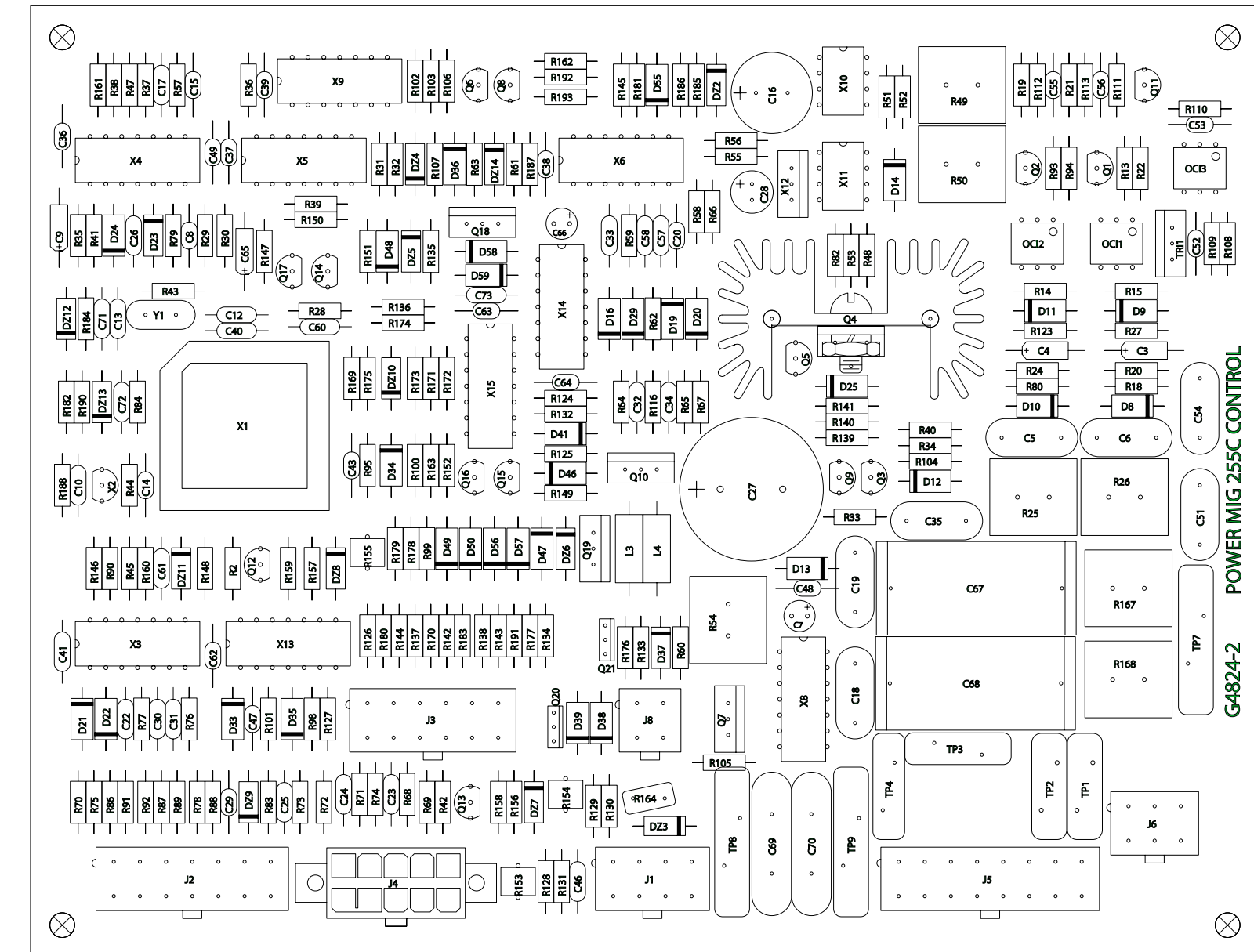

ITEM (USED WITH)*	QTY	PART NUMBER	DESCRIPTION
1	1	G4824-D	PC BOARD BLANK
2 (Q4)*	1	CF000003	6-32 X .375 ROUND HEAD MACHINE SCREW
3 (Q4)*	1	E106A-13	# 6 LOCK WASHER
4 (Q4)*	AS REQ	E1868	THERMO JOINT COMPOUND
5 (X1)*	AS REQ	E2861	RTV SEALANT
6 (Q4)*	1	S18104-1	HEAT SINK,ALUMINUM,EXTRUDED,FOR 1 TO-220
7 (X1)*	1	S20209-52	SOCKET,IC,PLCC,52-PIN
8 (Q4)*	1	T13746	6-32 HEX NUT

REFER TO ELECTRONIC COMPONENT DATABASE FOR SPECIFICATIONS ON ITEMS LISTED BELOW

REFERENCES	QTY	PART NUMBER	DESCRIPTION
C3, C4, C9, C65	4	S13490-42	CAPACITOR,TAEL,1.0,35V,10%
C5, C6, C18, C19, C35, C51, C54	2	S13490-181	CAPACITOR,AEL,22,63V,20%
C7, C66			CAPACITOR,CEMO,.022,50V,20%
C8, C14, C20, C29, C36, C37, C38, C39, C43, C48, C49, C52, C53, C55, C56, C62, C63, C64			CAPACITOR,CEMO,0.1, 50V,10%
C10, C17, C22, C23, C24, C25, C26, C30, C31, C32, C33, C34, C40, C41, C46, C57, C58, C60, C61, C71, C72, C73	2	S16668-1	CAPACITOR,CEMO,22pF, 100V,5%
C15	1	S16668-8	CAPACITOR,CEMO,330pF,100V,5%
C16	1	S13490-179	CAPACITOR,AEL,1000,35V,20%
C27	1	S13490-182	CAPACITOR,AEL,3300,63V,20%
C28	1	S13490-197	CAPACITOR,AEL,82.35V,20%,LOW-ESR
C47	1	S16668-6	CAPACITOR,CEMO,4700pF,50V,10%
C67, C68	2	S20500-2	CAPACITOR,PPMF,0.47,630V,10%,BOX
C69, C70	2	T11577-46K	CAPACITOR,CD,.05,600V,+80/-20%
D8, D9, D10, D11, D12, D13, D14, D16, D19, D20, D21, D22, D24, D25, D29, D33, D34, D35, D36, D38, D39, D41, D46, D47, D48, D49, D50, D55, D56, D57, D58, D59	2	T12705-23	DIODE,SCHOTTKY,AXLDS,1A,30V,1N5818
D23, D37	5	T12702-45	ZENER DIODE,1W,18V,5%,1N4746A
D22, D23, D24, D25, D26	2	T12702-52	ZENER DIODE,1W,5.1V,5%,1N4733A
D27, D28	2	T12702-52	ZENER DIODE,1W,6.2V,5%,1N4735A
D29, D210, DZ11, DZ12, DZ13, DZ14	1	S18248-8	CONNECTOR,MOLEX,MINI,PCB,8-PIN
J1	1	S18248-14	CONNECTOR,MOLEX,MINI,PCB,14-PIN
J2	1	S18248-12	CONNECTOR,MOLEX,MINI,PCB,12-PIN
J3	1	S24020-10	CONNECTOR,MOLEX,MINI,PCB,10-PIN,TIN
J4	1	S18248-16	CONNECTOR,MOLEX,MINI,PCB,16-PIN
J5	1	S18248-6	CONNECTOR,MOLEX,MINI,PCB,6-PIN
J6	1	S18248-4	CONNECTOR,MOLEX,MINI,PCB,4-PIN
J8	2	T12218-7	CHOKE,330UH,10%,110MA, MOLDED
L3, L4	2	S15000-30	OPTOCOUPLER,TRIAC,DRV,RANDOM,800V
OC1, OC2	2	S15000-30	OPTOCOUPLER,TRIAC,DRV,RANDOM,800V
OC3	1	S15000-31	OPTOCOUPLER,TRIAC,DRV,RANDOM,800V
Q1, Q2, Q3, Q6, Q11, Q12, Q13, Q14	1	T12704-41	TRANSISTOR,N,TO220,8A,150V,MJE15030
Q4	4	T12704-35	TRANSISTOR,NPN,TO226,0.5A, 300V,MPS-A42
Q5, Q9, Q15, Q16	4	T12704-88	TRANSISTOR,NMF,TO220,45A,100V(SS)
Q7, Q10, Q18, Q19	2	T12704-69	TRANSISTOR,PNP,TO226,0.5A, 40V,2N4403
Q8, Q17	2	T12704-109	TRANSISTOR,NMF,IPAK,TO-251,10A,100V(SS)
Q20, Q21	2	T12704-109	TRANSISTOR,NMF,IPAK,TO-251,10A,100V(SS)
R2, R30, R42, R45, R70, R90, R103, R148, R182, R188			RESISTOR,MF,1/4W,4.75K,1%
R13, R22, R93, R94, R132	5	S19400-6810	RESISTOR,MF,1/4W,681,1%
R14, R15, R27, R123	4	S19400-15R0	RESISTOR,MF,1/4W,15.0,1%
R18, R20, R24, R80	4	S19400-5620	RESISTOR,MF,1/4W,562,1%
R19, R21, R58, R83, R144, R178, R179, R180			RESISTOR,MF,1/4W,2.21K,1%
R25, R26, R49, R50	4	S25365-51R0	RESISTOR,STAND-UP,WW,5W,51.0,5%
R28, R61, R142, R143, R147, R191			RESISTOR,MF,1/4W,6.81K,1%
R29, R100, R110	3	S19400-1501	RESISTOR,MF,1/4W,1.50K,1%
R31, R106, R150, R193	4	S19400-5621	RESISTOR,MF,1/4W,5.62K,1%
R32	1	S19400-2672	RESISTOR,MF,1/4W,26.7K,1%
R33, R38, R79, R149	4	S19400-2212	RESISTOR,MF,1/4W,22.1K,1%
R34, R40	2	S19400-33R2	RESISTOR,MF,1/4W,33.2,1%
R35, R51, R181	3	S19400-1502	RESISTOR,MF,1/4W,15.0K,1%
R36	1	S19400-2671	RESISTOR,MF,1/4W,2.67K,1%
R37, R59, R66, R69, R73, R74, R86, R87			RESISTOR,MF,1/4W,44.2K,1%
R39, R68, R71, R72, R91, R92, R111			RESISTOR,MF,1/4W,3.32K,1%
R41, R65, R75, R84, R112, R113, R133, R134, R137, R138, R139, R140, R141			RESISTOR,MF,1/4W,10.0K,1%
R43, R183	2	S19400-1004	RESISTOR,MF,1/4W,1.00M,1%
R44, R47, R109, R145, R146			RESISTOR,MF,1/4W,1.00K,1%
R48	1	S19400-2801	RESISTOR,MF,1/4W,2.80K,1%
R52, R98	2	S19400-3011	RESISTOR,MF,1/4W,3.01K,1%
R53	1	S19400-5111	RESISTOR,MF,1/4W,5.11K,1%
R54	1	S25365-00R1	RESISTOR,STAND-UP,WW,5W,0.1,5%
R55, R56	2	S19400-26R7	RESISTOR,MF,1/4W,26.7,1%
R57	1	S19400-2430	RESISTOR,MF,1/4W,243,1%
R60	1	S19400-2432	RESISTOR,MF,1/4W,24.3K,1%
R62, R63, R76, R77, R78, R82, R95, R105, R124, R125, R126, R127, R128, R129, R130, R131			RESISTOR,MF,1/4W,100,1%
R64, R67	2	S19400-5110	RESISTOR,MF,1/4W,511,1%
R88, R89	2	S19400-1622	RESISTOR,MF,1/4W,16.2K,1%
R99	1	S19400-1652	RESISTOR,MF,1/4W,16.5K,1%
R101, R102	2	S19400-1372	RESISTOR,MF,1/4W,13.7K,1%
R104, R152	2	S19400-7500	RESISTOR,MF,1/4W,750,1%
R107, R151	2	S19400-4750	RESISTOR,MF,1/4W,475,1%
R108	1	S19400-2670	RESISTOR,MF,1/4W,267,1%
R116	1	S19400-2802	RESISTOR,MF,1/4W,28.0K,1%
R135, R136, R187	3	S19400-4752	RESISTOR,MF,1/4W,47.5K,1%
R153, R154, R155	3	S18380-14	THERMISTOR,PTC,500OHMS,28mA
R156, R157	2	S19400-3320	RESISTOR,MF,1/4W,332,1%
R158, R159	2	S19400-2210	RESISTOR,MF,1/4W,221,1%
R160, R161, R162, R163, R184, R185, R186, R190			RESISTOR,MF,1/4W,2.00K,1%
R164	1	S18380-5	THERMISTOR,PTC,0.5-1.17 OHMS,0.5A
R167, R168	2	S25365-10R0	RESISTOR,STAND-UP,WW,5W,10.0,5%
R169, R170, R171, R172, R173, R174, R175			RESISTOR,MF,1/4W,100K,1%
R176, R177	2	S19400-2000	RESISTOR,MF,1/4W,200,1%
R192	1	S19400-3322	RESISTOR,MF,1/4W,33.2K,1%
TP1, TP2	2	T13640-15K	MOV,50VRMS,15J,14MM
TP3, TP4	2	T13640-9K	MOV,75VRMS,22J,14MM
TP7, TP8, TP9	3	T13640-18	MOV,320VRMS,150J,20MM
TR11	1	S15161-27	TRIAC,TO220,8A,800V
X1	1	M15101-10	IC,CMOS,MCU,ONE-TIME-PROM,PLCC,68HC711E9C
X2	1	M15102-3	IC,CMOS,UNDERVOLT-SENSING,RESET,MCU(SS)
X3	1	S17900-8	IC,CMOS,INVERTER,SCHMITT,HEX,HC14A(SS)
X4, X5	2	S15128-11	IC,COMPARATOR,QUAD,2901N
X6	1	S15128-16	IC,OP-AMP,QUAD,HIGH-PERF,1014
X8, X14	2	S15018-4	IC,CMOS,INVERTER,SCHMITT,HEX,4584(SS)
X9, X13	2	S15018-6	IC,CMOS,SWITCH,ANALOG,QUAD, 4066(SS)
X10, X11	2	S15128-10	VOLTAGE REF,ADJ, PRECISION,4311
X12	1	S15128-5	IC,VOLT REG,FIXED,3-T,(+),1A,5V,TO220
X15	1	S15128-4	OP-AMP,QUAD, GEN-PURPOSE,224N
Y1	1	S16665-11	CRYSTAL,QUARTZ,8.000MHZ,ATS-49

Return to Section TOC

Return to Master TOC

Return to Section TOC

Return to Master TOC

Return to Section TOC

Return to Master TOC

Return to Section TOC

Return to Master TOC

NOTE: Lincoln Electric assumes no responsibility for liabilities resulting from board level troubleshooting. PC Board repairs will invalidate your factory warranty. **Individual Printed Circuit Board Components are not available from Lincoln Electric.** This information is provided for reference only. Lincoln Electric discourages board level troubleshooting and repair since it may compromise the quality of the design and may result in danger to the Machine Operator or Technician. Improper PC board repairs could result in damage to the machine.



SCHEMATIC - DISPLAY PC BOARD (L10951)

Return to Section TOC
Return to Master TOC

Return to Section TOC
Return to Master TOC

Return to Section TOC
Return to Master TOC

Return to Section TOC
Return to Master TOC

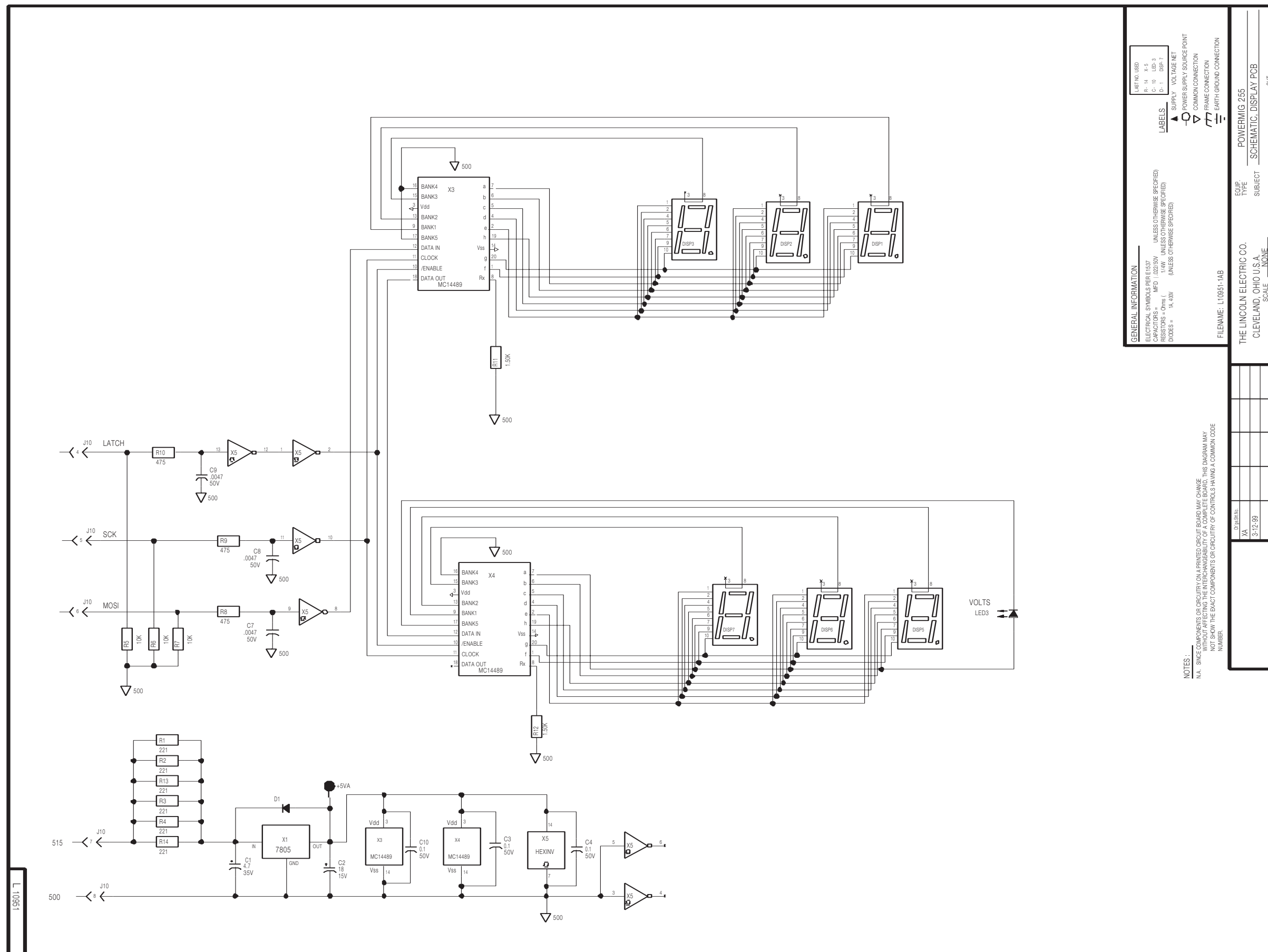

NOTES:
 N/A. SINCE COMPONENTS OR CIRCUITS ON A PRINTED CIRCUIT BOARD MAY CHANGE WITHOUT AFFECTING THE INTERCHANGABILITY OF A COMPLETE BOARD, THIS DIAGRAM MAY NOT SHOW THE EXACT COMPONENTS OR CIRCUITS OF CONTROLS HAVING A COMMON CODE NUMBER.

GENERAL INFORMATION
 ELECTRICAL SYMBOLS REFER TO: UNLESS OTHERWISE SPECIFIED:
 RESISTORS - Ohms (UNLESS OTHERWISE SPECIFIED)
 CAPACITORS - pF (UNLESS OTHERWISE SPECIFIED)
 DIODES - 1A, 0.0V (UNLESS OTHERWISE SPECIFIED)

FILENAME: L10951-1AB

DR.	GT.	DATE	2/20/88	CHK.	L. 10951
DR.	GT.	DATE	3-12-99	CHK.	L. 10951
EQUIP. TYPE		POWERMIG 255			
SUBJECT		SCHEMATIC, DISPLAY PCB			

NOTE: This diagram is for reference only. It may not be accurate for all machines covered by this manual.



PC BOARD ASSEMBLY - DISPLAY - (L10952)

Return to Section TOC
Return to Master TOC
Return to Section TOC
Return to Master TOC
Return to Section TOC
Return to Master TOC
Return to Section TOC
Return to Master TOC

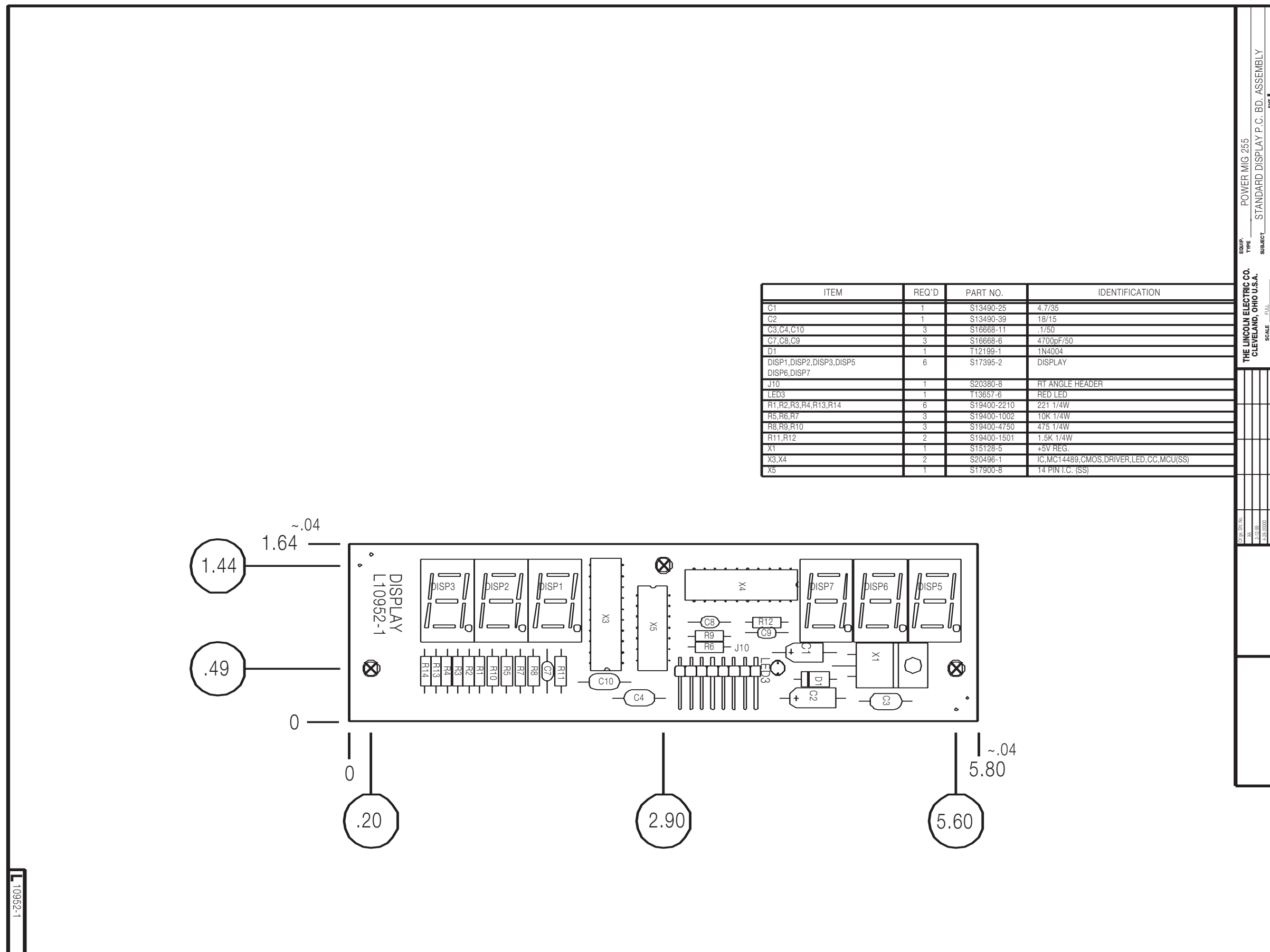

ITEM	REQ'D	PART NO.	IDENTIFICATION
C1	1	S13490-25	4.7/35
C2	1	S13490-39	18/15
C3,C4,C10	3	S16668-11	.1/50
C7,C8,C9	3	S16668-6	4700pF/50
D1	1	T12199-1	1N4004
DISP1,DISP2,DISP3,DISP5 DISP6,DISP7	6	S17395-2	DISPLAY
J10	1	S20380-8	RT ANGLE HEADER
LED3	1	T13657-6	RED LED
R1,R2,R3,R4,R13,R14	6	S19400-2210	221 1/4W
R5,R6,R7	3	S19400-1002	10K 1/4W
R8,R9,R10	3	S19400-4750	475 1/4W
R11,R12	2	S19400-1501	1.5K 1/4W
X1	1	S15128-5	+5V REG.
X3,X4	2	S20496-1	IC,MC14489,CMOS,DRIVER,LED,CC,MCU(SS)
X5	1	S17900-8	14 PIN I.C. (SS)

EQUIP. TYPE POWER MIG 255
SUBJECT STANDARD DISPLAY P.C. BD. ASSEMBLY
THE LINCOLN ELECTRIC CO.
CLEVELAND, OHIO U.S.A.
SCALE FULL
DATE 5-20-88
DR. J.L.
CHK. NO. L 10952-1

NOTE: Lincoln Electric assumes no responsibility for liabilities resulting from board level troubleshooting. PC Board repairs will invalidate your factory warranty. **Individual Printed Circuit Board Components are not available from Lincoln Electric.** This information is provided for reference only. Lincoln Electric discourages board level troubleshooting and repair since it may compromise the quality of the design and may result in danger to the Machine Operator or Technician. Improper PC board repairs could result in damage to the machine.



SVM ERROR REPORTING FORM

We need to know if there are errors in our manuals. We also value any suggestions as to additional tests or procedures that would make this SVM a better tool for you.

If you discover new or different "Problems or Symptoms" that are not covered in the three column troubleshooting chart, please share this information with us. Please include the machine's code number and how the problem was resolved.

Thank You,
Technical Services Group
Lincoln Electric Co.
22801 St. Clair Ave.
Cleveland, Ohio 44117-1199

FAX 216-481-2309

SVM Number _____

Page Number if necessary _____

Your Company _____

Your Name _____

Please give detailed description below:

SD287 04/06

Free Manuals Download Website

<http://myh66.com>

<http://usermanuals.us>

<http://www.somanuals.com>

<http://www.4manuals.cc>

<http://www.manual-lib.com>

<http://www.404manual.com>

<http://www.luxmanual.com>

<http://aubethermostatmanual.com>

Golf course search by state

<http://golfingnear.com>

Email search by domain

<http://emailbydomain.com>

Auto manuals search

<http://auto.somanuals.com>

TV manuals search

<http://tv.somanuals.com>