



# Service Kit

## 753-05193

Date: 9/23/2005

Subject: Log Splitter Wedge Shim

Models Affected: 2004 and 2005 Model Year Log Splitters built between May 1, 2004 and September 15, 2005.

**Read through and understand these instructions completely before proceeding with repair.**

**PURPOSE:**

This service kit provides a shim (spacer) to reduce the gap between the end of the cylinder ram and the back of the wedge. Perform the Pre-service Inspection to determine if this kit is required or not.

**NOTE:** These materials are prepared for use by trained technicians who are experienced in the service and repair of equipment of the kind described in this publication, and are not intended for use by untrained or inexperienced individuals. Such individuals should seek the assistance of an authorized service technician or dealer.

**NOTE:** Save this Instruction Sheet. Refer to it when ordering replacement parts.

### Service Kit Contents

(See Figure 1)

ITEM NO.	PART NUMBER	QTY	DESCRIPTION
1	681-04052	1	SHIM ASSEMBLY
2	710-1806	1	SCREW: HHCS: 1/2"-13 x 3.25: GR5
3	712-3022	1	NUT: LOCK: 1/2"-13
4	769-02077	1	THIS INSTRUCTION SHEET

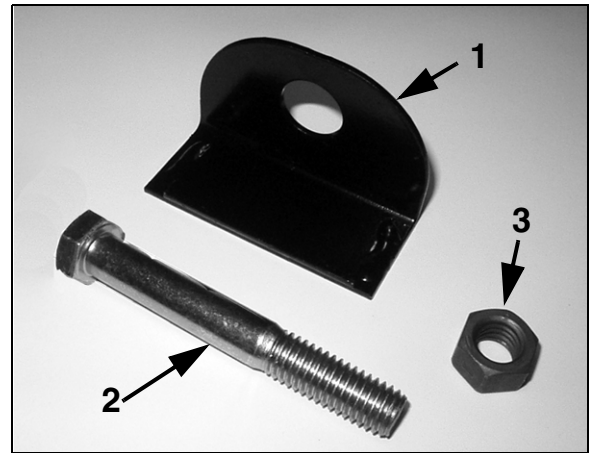

FIGURE 1

**Pre-service Inspection:**

These instructions are written with the assumption that the unit has been in service already or is being prepared for delivery.

1. To determine if this service kit is required the following check must be made.
2. Place beam in the horizontal position and lock in place.
3. Check engine oil level and hydraulic fluid level.
4. Start engine and extend ram so the splitting wedge is about 4"- 8" from beam's foot. Turn off engine.
5. Release pressure in the system by shutting the direction control lever from the forward to the retract positions several times.
6. Using two 3/4" wrenches loosen the cylinder to wedge mounting bolt to relax the wedge.
7. With wood blocking braced against the beam's foot, push the wedge back toward the cylinder's ram end and secure in this position.
8. Using a .035" feeler gage, try to insert the gage between the end of the ram and the back side of the wedge pocket. See Figure 2.

**If the gage does not go in the gap, the gap is correct and this kit is not required. Stop here.**

**If the gage goes into the gap, the shim provided should be installed. Proceed to Step 9.**

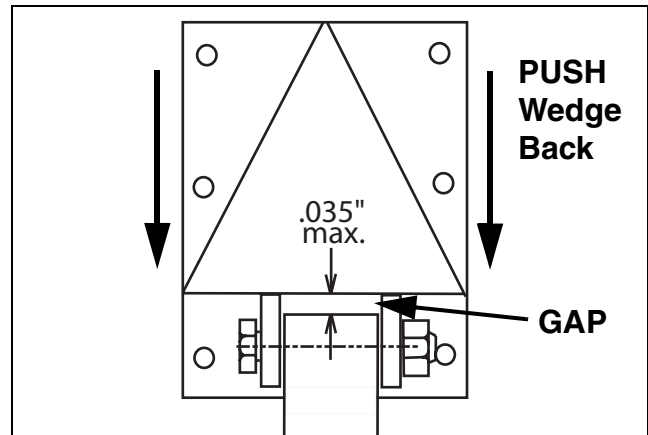
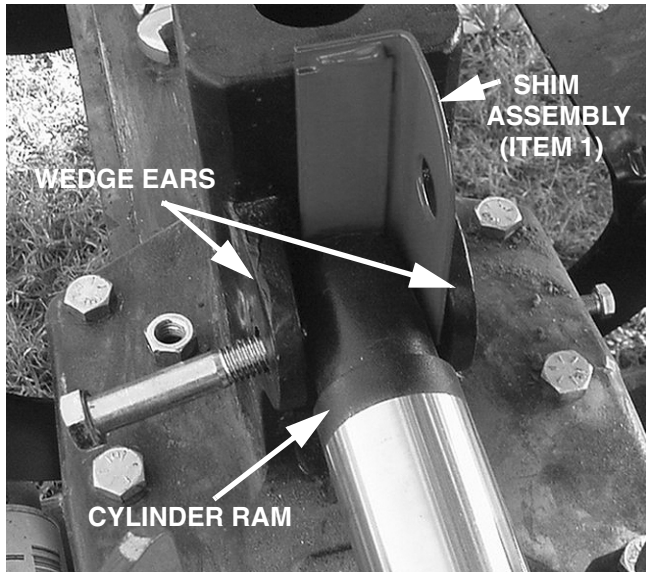

FIGURE 2

9. Using two 3/4" wrenches, remove and discard the bolt and nut securing the cylinder ram to the wedge.

10. Slide the wedge away from the cylinder ram enough to slip the Shim Assembly, Item 1, between the wedge and cylinder ram. See Figure 3.

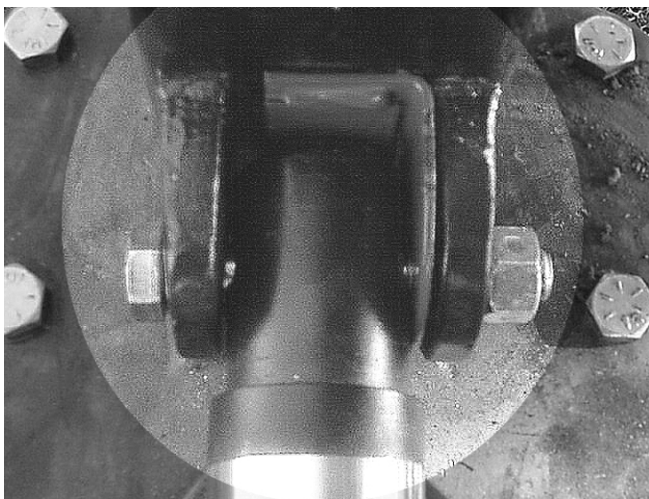

**FIGURE 3**

11. Re-align the hole in the cylinder ram end and the holes in the wedge ears.

12. Slip the new 1/2"-13 x 3.25 Screw, Item 2, through the wedge, cylinder ram and shim assembly holes.

13. Secure with the new 1/2"-13 Lock Nut, Item 3. DO NOT tighten the lock nut down. There should be only 2 to 3 threads that show past the nut. See Figure 4.



14. This completes the installation of this service kit.

## NOTES

## Free Manuals Download Website

<http://myh66.com>

<http://usermanuals.us>

<http://www.somanuals.com>

<http://www.4manuals.cc>

<http://www.manual-lib.com>

<http://www.404manual.com>

<http://www.luxmanual.com>

<http://aubethermostatmanual.com>

Golf course search by state

<http://golfingnear.com>

Email search by domain

<http://emailbydomain.com>

Auto manuals search

<http://auto.somanuals.com>

TV manuals search

<http://tv.somanuals.com>