

Owner's Operating Service Instruction Manual

10¢

Model No.
215-100AB2

- ASSEMBLY
- OPERATION
- REPAIR PARTS

VERTICAL ROTARY TILLER

WARRANTY

For one year from date of purchase, MTD Products Inc will replace for the original purchaser, free of charge, F.O.B. factory or authorized service firm, any part or parts found to be defective in material or workmanship. All transportation charges on parts submitted for replacement under this warranty must be paid by the purchaser. This warranty does not include replacement of parts which become inoperative through misuse, excessive use, accident, neglect, improper maintenance or alterations by unauthorized persons. This warranty does not include the engine, motor, battery, battery charger or any component parts thereof. For service on these units, refer to the applicable manufacturer's warranty.

The above warranty will apply only to the original owner and will be effective only if the warranty card has been properly processed. It will not apply where the unit has been used commercially.

Warranty service is available through your local authorized service dealer or distributor. **UNDER NO CIRCUMSTANCES WILL THE RETURN OF A COMPLETE UNIT BE ACCEPTED BY THE FACTORY UNLESS PRIOR WRITTEN PERMISSION HAS BEEN EXTENDED.**

SAFETY RULES

1. Your tiller is a precision piece of power equipment. Exercise extreme CAUTION at all times.
2. Do not attempt to start engine with the clutch control in the engaged or FORWARD position.
3. Stand clear of tines when starting engine. Never stand in front of, or work on tines while the engine is running.
4. NEVER place hands or feet in the vicinity of the tines while the engine is running.
5. Always stop engine when tiller is not in actual use.
6. Always disconnect spark plug wire during repairs or refueling operations.
7. Do not fill fuel tank while engine is running. Do not spill gasoline on hot engine.

Your rotary tiller is a precision built machine designed to take the work out of gardening and other related chores. It can be used for seed bed preparation, tilling, cultivating, furrowing, composting and mulching. Like any other piece of power equipment, it requires a certain amount of care and maintenance. In return for this, it will give a maximum of service and efficiency. Read these instructions carefully before assembling or operating your tiller. Through proper care and operation, you will obtain long, efficient service and trouble free operation.

NOTE

Your tiller is shipped without oil in the engine crankcase. See engine manual for correct type and amount.

ASSEMBLY — ONE PIECE HANDLE

Your rotary tiller is shipped complete in a single carton. The tines, wheels, handle and depth bar are to be assembled. This is done in the manner described below.

Tines—Mount tines on tine shaft as shown. (See page 8.) Tines must be mounted with the cutting edges facing the correct direction. The tiller will not operate properly unless the sharpened surface of the tines enter the soil first. Secure tines in position on tine shaft with cap screws (35), and nuts (24).

NOTE

Dust pads (21 and 22) are provided in screw pack. Install dust pads as shown on page 8.

Wheels — Insert axle bolts (23) into wheel hubs. Place washers (26) between wheel and leg. Attach wheel and axle assemblies to outside of tiller legs (27) and (30). Secure with nuts (29) and lockwashers (28). Tighten securely. See page 6 for correct sequence of parts.

Handle — Assemble the handle brackets (8) to the handle (2) with hex head screw (11), lockwashers (9) and hex nuts (10). DO NOT tighten. Place the handle brackets (8) in the tailpiece slots. Line up lower holes in handle brackets with mounting holes in tailpiece assembly. Secure with carriage bolt 5/16-18 x 3/4" Lg. (20), lockwasher (13) and hex nut (12). Line up upper holes in handle brackets with mounting holes in mounting plate assemblies (19) and secure with carriage bolt (20), lockwasher (13) and hex nut (12). See page 6 for correct sequence. Tighten all nuts and bolts securely.

CLUTCH CONTROL LEVER ASSEMBLY

Clutch Lever—Assemble in this order: rubber washer (42), steel washer (41), clutch lever assembly (43), (rod bracket to the front), steel washer (41) and lock nut (40). Tighten until rubber washer compresses slightly. (See page 6.)

Clutch Control Assembly — Screw the ferrule (37) on the threaded end of the control rod (38) until about 1/2" of the threads show above the ferrule. Insert the ferrule through the control pivot lever (36), fasten with flat washer (35) and cotter hairpin (34). Put the clutch handle in the neutral position. Insert the control rod in the bracket on the clutch lever and secure with a cotter hairpin (34) through the center of the bracket. Adjust the ferrule so the belt is slack when the clutch lever is in the neutral position. (See page 6.)

Depth Bar — Attach depth bar (18) in desired position with clevis pin (17) and locking pin (15). (See page 6.)

Grips — Assemble grips (1) to handle bars.

CHECK LIST BEFORE OPERATION

1. Remove spark plug wire from spark plug and ground. Check tiller tines for proper installation. With throttle control lever set on STOP position and the clutch control handle set in FORWARD position, slowly crank engine to determine direction of tine rotation. Be sure all tines are mounted so the sharpened edges enter the soil first.
2. Now place the clutch control handle in NEUTRAL position. Slowly crank engine. The tines should not rotate.
3. Check all nuts and bolts for proper tightness. This is especially important during the initial operation period. Make this same check periodically thereafter.

4. Check gear case for proper lubricant level. With tiller on a level surface, lubricant level should be up to the front pipe plug opening. This can be checked by removing front pipe plug. Maintain correct lubricant level with Mobilube SAE 140 Gear Oil or equivalent. The gear case holds five (5) ounces of lubricant.
5. Fill fuel tank with clean, fresh, regular grade gasoline. This should be used at all times.
6. Check engine crankcase for proper oil level. The engine is shipped without oil in the crankcase. Be sure to fill crankcase before starting engine. Be sure crankcase is FULL. See engine manual for correct type and amount.

NOTE: The engine is warranted separately by the engine manufacturer. For warranty service contact the engine manufacturer or their local authorized service station. All important information pertaining to care and operation is included in the engine manual.

STARTING YOUR TILLER

1. Be sure clutch control handle is in NEUTRAL position.
2. Move throttle lever to START position on engine.
3. After cranking the engine several times or as the engine fires, move the throttle lever to RUN position.
4. Adjust throttle lever for desired operating speed.
5. To stop engine, move throttle lever to STOP position. Keep throttle lever in STOP position at all times when tiller is not in use.

NOTE

A brief break-in period is essential to insure maximum engine life. This consists of running the engine at half speed for a period of time required to use one tank of gasoline. This is necessary on the initial run only. It is also recommended that the oil be changed after five (5) hours of operation. This allows for the removal of impurities which may have accumulated during the break-in period. Subsequent oil changes should be made as stated in the engine manual. Always check oil before using your tiller. Be sure oil level is adequate.

OPERATING INSTRUCTIONS

For your own convenience and safety, observe all safety suggestions shown in this manual. Your tiller is not a toy, it is a precision piece of power equipment. Treat it as such.

It is important to recognize the fact that the forward and penetrating action of the rotary tiller is obtained from the rotating action of the tines in the soil. The depth bar acts as a brake for the tiller and controls the depth and speed at which the machine will operate. By lowering the setting of the depth bar, the forward speed of the machine is reduced and the working depth of the tines is increased. Raising the setting of the depth bar increases the forward speed and reduces the working depth. When soil conditions are severe and several passes must be made over a certain area, the depth bar setting should be lowered each time a pass is made. Further control of tilling depth and travel speed can be obtained by variation of pressure on the handles or the throttle setting. A downward pressure on the handles will increase the working depth and reduce the forward speed. An upward pressure on the handles will reduce the working depth and increase the forward speed. The type of soil and working conditions will determine the actual setting of the depth bar and the handle pressure required.

1. Tine engagement and forward travel is achieved by moving the clutch lever to FORWARD position. Tine rotation and forward motion are stopped by moving the clutch lever to NEUTRAL position.
2. The throttle lever adjusts the engine speed. It also gives fingertip control of the carburetor and magneto stop switch. When the throttle lever is pushed completely to the right from behind the tiller, the carburetor is in START position. Pulling the lever to the left reduces the engine speed to SLOW. When the lever is pulled completely to the left from behind the tiller, the magneto stop switch grounds out the spark and stops the engine.
3. When the depth bar is positioned out of ground engagement, self-propelled transporting of the tiller is easily achieved. With no pressure on the handles and the throttle lever set for SLOW engine speed, move the clutch control handle to the FORWARD position and let the tiller gently propel itself.

ADJUSTMENTS

Belts—Belt slack is taken up by a spring loaded idler pulley. Because of this, belt adjustment is not required.

Clutch—No adjustment of the lower clutch rod is required. This is done automatically by the spring loaded idler.

NOTE: Belt and clutch adjustments can be made by moving the engine bed. Loosen the four bolts which secure it and move the engine bed forward or backward as required. Adjusting the control rod will also effect the belt and clutch adjustment. These adjustments may be necessary if handle position is changed.

Handle—The position of the handle may be adjusted by removing and moving carriage bolts to the desired mounting holes. Adjustment should be made for the most convenient operating height.

Wheels—Wheel positions may be varied to give further adjustment of handle height. Various wheel positions also give variations of the leverage and weight distribution over the tines. Wheels should be set to suit the local soil conditions and the operator's convenience.

Tines—The standard width of cut is 26". Because of the various types of work to which the tiller may be put, variation in the tilling widths may be necessary. This can be accomplished in a number of ways.

1. Standard tine arrangement ----- 26"
2. Remove tines that point outward from outer tine assemblies. Tines may be interchanged with opposite sides -----20"
3. Add tine extensions to standard arrangement (See page 5.) ----- 40"

NOTE: When adjusting tines, be sure the cutting edges enter the soil first.

MAINTENANCE AND LUBRICATION

Engine—Service engine in accordance with the engine manufacturer's owner's guide.

NOTE: To drain oil, remove oil filler plug and tip tiller on its side. Drain oil while the engine is warm. See engine manual for filling instructions.

Gear Case— Proper lubricant level should be up to the front pipe plug. Check with tiller on a level surface. Add enough to bring level up to front pipe plug hole. Use Mobilube SAE 140 Gear Oil or equivalent. Gear case should be maintained with five (5) ounces of lubricant.

Belt — Access to V belt and pulley assemblies is accomplished by removing the engine and engine bed as described below.

1. Remove four cap screws which secure engine bed to mounting plate assembly. Remove engine bed with engine attached.
2. Remove hex screw, lockwasher and flatwasher in 4½" pulley. Remove pulley and "V" belt. The belt clip on idler must be loosened to remove belt, mark correct location of belt clip in relation to idler before loosening. This can be done by scribing the belt clip and the end of the weld bolt in idler with a file. It is most important that this clip be reassembled in the right position.

3. Position new belt on 4½" pulley and reinstall on gear case shaft. Pulley must be mounted in position so that it will line up with engine pulley when assembly is completed. The correct position is that point at which the center of the pulley is 1½" above the mounting plate assembly. Tighten hex screw, lockwasher and flat washer securely.
4. Line up the belt clip in original position and tighten securely. Make sure belt is inside belt guards. While holding the belt taut (grasp at extreme rear position), move clutch belt lever to FORWARD and NEUTRAL position. If belt clip touches belt with lever in either position, readjust position of clip.
5. Move clutch lever to NEUTRAL position. Remove inspection plate from engine bed.
6. Replace engine bed on mounting plate assembly. Move engine bed and engine as far forward as possible.
7. Remove inspection plate (See page 8.) from engine bed and reach through inspection hole and guide belt into position on engine pulley.
8. Check visually through inspection hole to make sure belt is inside all belt guards and that pulleys are in proper alignment. A flashlight will help you make this check quickly and easily.
9. Line up mounting holes of engine bed and mounting plate then replace cap screws. Do not tighten cap screws until all four screws are in place. Replace inspection plate.

REPLACING TILLER GEAR CASE OIL SEALS

1. Drain lubricant.
2. Remove tine assemblies.
3. Remove bearing cap. (See reference 16 on page 10.)
4. Remove bearings, worm wheel and tine shaft. Do not remove bearing races.
5. Remove oil seals from gear case and bearing cap.
6. Remove all burrs from holes in tine shaft.
7. Dip oil seals in lubricant and then insert one in gear case and one in bearing cap.
8. Wipe tine shaft clean of filings and lubricate before assembling with bearings and worm wheel in gear case.
9. Replace bearing cap. **CAUTION:** Do not damage oil seals. The open flanges face to the outside of the gear case.

10. Tighten bearing cap, retighten screws evenly.
11. Replace tine assemblies and add lubricant. (See page 4.)

General—Check periodically all nuts and bolts. Loose nuts and bolts can cause permanent damage to your unit. Keep all nuts and bolts securely tightened.

Storage—The following steps should be taken to prepare your tiller for storage.

1. Clean tiller thoroughly and lubricate as described in the preceding instructions.
2. Coat tilling tines with grease to prevent rusting.
3. Prepare engine for storage in accordance with engine manufacturer's owner's guide.

4. Block tiller legs to raise tires clear of floor. Be sure tiller is level.
5. Store in a dry, clean area.

ATTACHMENTS

Extension Tines—This attachment is available to increase your tilling width up to 40". Extension tines are easily installed and removed. Order under part number 295-162A.

Furrow Opener—This attachment is easily installed on the depth bar of your tiller. It can be used for either furrowing or hilling operations. These attachments are available through your local dealer.

For wide (2" x .43") depth bar, order furrow opener 295-179A.

215-100AB2

IF YOU WRITE TO US ABOUT THIS ARTICLE
OR IF YOU ORDER REPLACEMENT PARTS AL-
WAYS MENTION THIS MODEL & SERIAL NO
MODEL

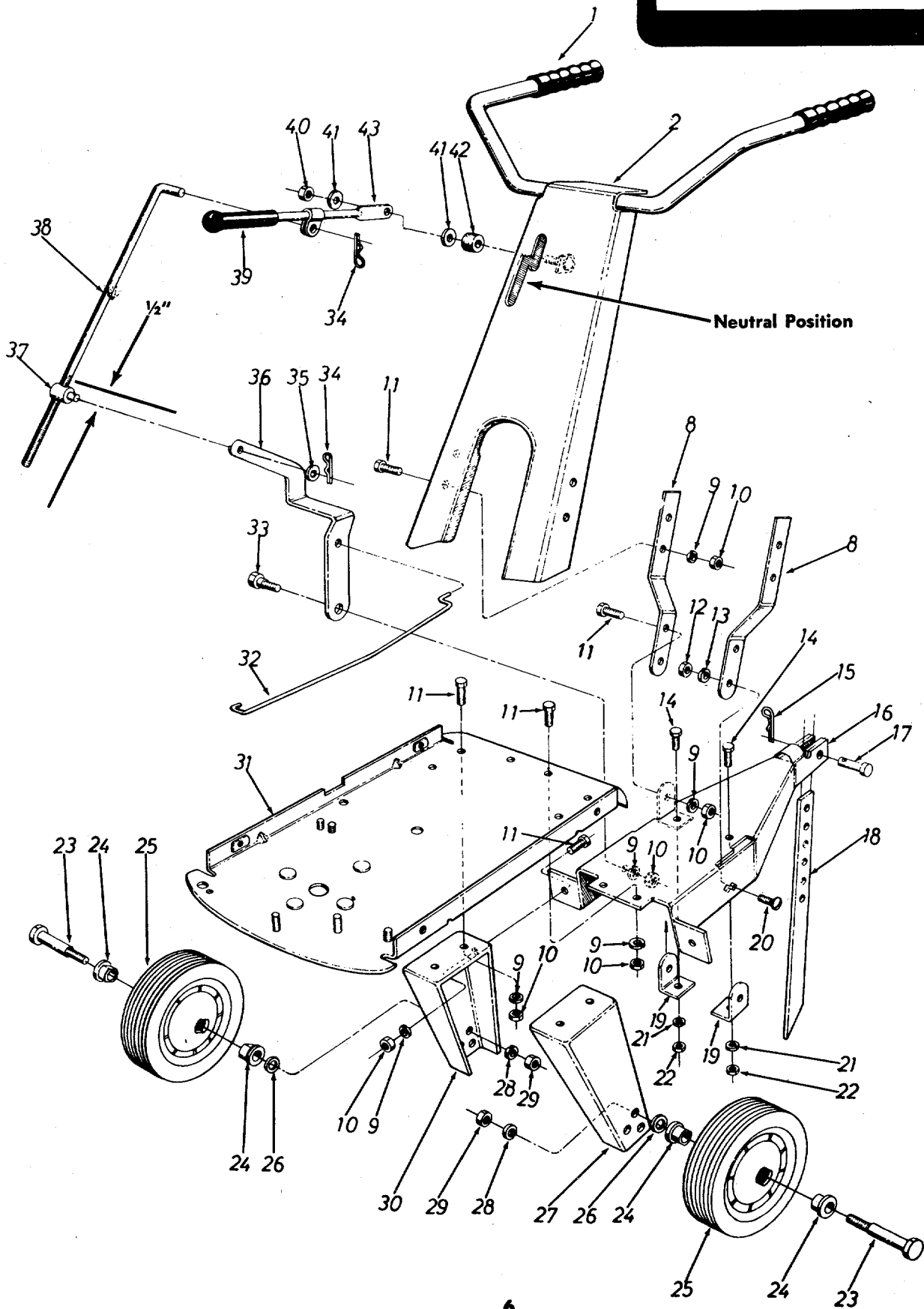

PARTS LIST FOR MODEL 215-100AB2

EF. NO.	PART NO.	COLOR CODE	DESCRIPTION	NEW PART	REF. NO.	PART NO.	COLOR CODE	DESCRIPTION	NEW PART
1	01166		Grip—Black		25	734-0585		Wheel Ass'y. 9.0 x 1.75	
2	04624-474		Handle Ass'y.		26	736-0253		Bellville Wash. .505 I.D. x 1.00 O.D.	
8	04386-474		Handle Mount Brackets						
9	736-0169		L-Wash. 3/8" Scr.*		27	04109-474		Leg—Left Hand	
10	712-0798		Hex Nut 3/8-16 Thd.*		28	736-0921		L-Wash 1/2" Scr.*	
11	710-0253		Hex Scr. 3/8-16 x 1.00" Lg.*		29	712-0206		Hex Nut 1/2-13 Thd.*	
12	712-0267		Hex Nut 5/16-18 Thd.*		30	04110-474		Leg—Right Hand	
13	736-0119		L-Wash. 5/16" Scr.*		31	04105-474		Mounting Plate Ass'y.	
14	710-0118		Hex Scr. 5/16-18 x .75" Lg.*		32	747-0148		Lower Control Rod	N
15	732-0194		Spring Pin		33	738-0183		Shoulder Scr. .500" Dia. x .215	
16	04329-474		Tail Piece Ass'y.		34	714-0115		Cotter Pin 1/8" Dia. x 1.00" Lg.*	
17	711-0231		Clevis Pin .500" Dia.		35	736-0204		Fl-Wash. .344" I.D. x .62 O.D.	
18	04668-474		Depth Bar	N	36	04619		Control Pivot Lever	
19	04124-474		Handle Mount Brackets		37	711-0392		Adjustment Ferrule	
20	710-0276		Carriage Bolt 5/16-18 x 1.00" Lg.*		38	711-0502		Control Rod 20"	
					39	720-0143		Grip—Black	
21	736-0119		L-Wash. 5/16" Scr.*		40	712-0158		Hex Inserted L-Nut 5/16-18 Thd.	
22	712-0267		Hex Nut 5/16-18 Thd.*		41	736-0159		Fl-Wash. .344 I.D. x .88 O.D.	
23	738-0240		Shoulder Scr. .625" Dia. x 2.75		42	735-0126		Rubber Wash. .33 I.D. x .87 O.D.	
24	741-0116		Flange Brg with. Flats .631 I.D.		43	04392		Clutch Lever Ass'y.	

* For faster service, obtain standard nuts, bolts, and washers locally. If these items cannot be obtained locally, order by part number and size as shown on parts list.

(474—Citrus) *When ordering parts if color or finish is important, use the appropriate color code shown at left. (e.g. Citrus Finish—04624 (474).)*

The engine is not under warranty by the tiller manufacturer. If repairs or service is needed on the engine, please contact your nearest authorized engine service outlet. Check the "Yellow Pages" of your telephone book under "Engines-Gasoline."

Find us fast in the



215-100AB2

IF YOU WRITE TO US ABOUT THIS ARTICLE OR IF YOU ORDER REPLACEMENT PARTS ALWAYS MENTION THIS MODEL & SERIAL NO MODEL

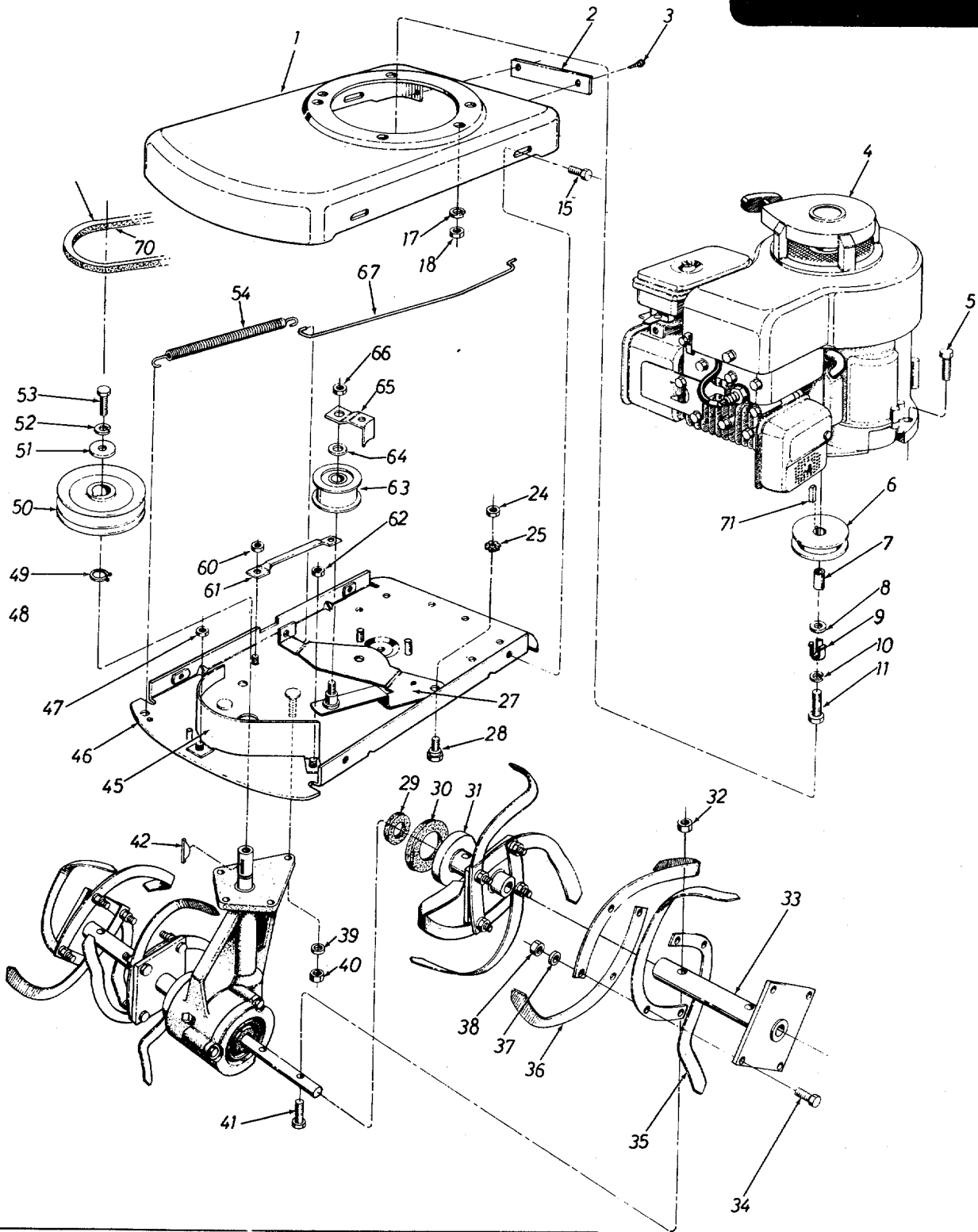

901-04291 TINE ASS'Y - COMPLETE - L.H. INNER	Optional Tine Extension Order Part No. 295-162A
901-04292 TINE ASS'Y - COMPLETE - R.H. INNER	
901-04293 TINE ASS'Y - COMPLETE - L.H. OUTER	
901-04294 TINE ASS'Y - COMPLETE - R.H. OUTER	

NOTE: Dust pads must be assembled as shown. (Ref. Nos. 29 and 30.)

PARTS LIST FOR MODEL 215-100AB2

REF. O.	PART NO.	COLOR CODE	DESCRIPTION	NEW PART	REF. NO.	PART NO.	COLOR CODE	DESCRIPTION	NEW PART
1	04258-474		Engine Bed		38	712-0241		Hex Nut 3/8-24 Thd.*	
2	04126		Inspection Plate		39	736-0169		L-Wash. 3/8" Scr.*	
3	710-0128		Hex F-Tapp Scr. #10-32 x .50" Lg.*		40	712-0798		Hex Nut 3/8-16 Thd.*	
4	—		Engine		41	710-0459		Hex Scr. 3/8-24 x 1.50" Lg. H.T.	
5	710-0158		Hex Scr. 5/16-24 x 1.25" Lg.*		42	714-0126		#9 Hi-Pro Key 3/16 x 3/4" Dia.	
6	756-0248		Sheave 3.0" x .50	N	45	04197		Belt Guard	
7	750-0284		Spacer	N	46	04691-474		Mounting Plate Ass'y.	N
8	736-0117		Fl-Wash. .385" I.D. x .62 O.D.		47	712-0107		Hex Cent. L-Nut 1/4-20 Thd.	
9	04259		Engine Shaft Spacer		49	716-0119		Snap Ring 3/4" Dia. Shatt	N
10	736-0169		L-Wash. 3/8" Scr.*		50	756-0249		Pulley—Double Groove 4.50" O.D.	
11	710-0152		Hex Scr. 3/8-24 x 1.00" Lg.*		51	736-0231		Fl-Wash. .344 x 1.125	
15	710-0259		Hex Sems Scr. 5/16-18 x .62" Lg.*		52	736-0119		L-Wash. 5/16" Scr.*	
17	736-0119		L-Wash. 5/16" Scr.*		53	710-0118		Hex Scr. 5/16-18 x .75" Lg.*	
18	712-0123		Hex Nut 5/16-24 Thd.*		54	732-0233		Spring Extension .62 O.D. x 4.94 Lg.	
24	712-0798		Hex Nut 3/8-16 Thd.*		60	712-0107		Hex Cent. L-Nut 1/4-20 Thd.	
25	736-0148		Ext. L-Wash. 3/8" Scr.*		61	04196		Hold Down Clamp	
27	04688		Idler Brkt. Ass'y.		62	712-0107		Hex Cent. L-Nut 1/4-20 Thd.	
28	738-0183		Shoulder Scr. .500" Dia. x .215		63	756-0370		Idler Bearing Ass'y.	
29	721-0120		Foam Seal 1.25" I.D. x 2.12" O.D.		64	736-0300		Fl-Wash. .385" I.D. x .870" O.D.	
30	721-0121		Foam Seal 2.25" I.D. x 2.94" O.D.		65	07353		Belt Clip	
31	04138		Inner Tine Adapter Ass'y.		66	712-0158		Hex Cent. L-Nut 5/16-18 Thd.	N
32	712-0116		Hex Center L-Nut 3/8-24 Thd.		67	747-0148		Lower Control Rod	
33	04134		Outer Tine Adapter Ass'y.		70	754-0196		V-Belt 1/2" x 30" Lg. (Forward Belt) Fiber "B"	
34	710-0191		Hex Scr. 3/8-24 x 1.25" Lg.*		71	714-0105		Sq. Key 3/16 x 3/16 x 1.00" Lg.	
35	742-0107		Tine 14"—Left Hand						
36	742-0108		Tine 14"—Right Hand						
37	736-0169		L-Wash. 3/8" Scr.*						
					26	4204		Belt pusher	

* For faster service, obtain standard nuts, bolts, and washers locally. If these items cannot be obtained locally, order by part number and size as shown on parts list.

(474—Citrus) *When ordering parts if color or finish is important, use the appropriate color code shown at left. (e.g. Citrus finish—04624(474).*

The tiller is not under warranty by the tiller manufacturer. If repairs or service is needed on the engine, please contact your nearest authorized engine service outlet. Check the "Yellow Pages" of your telephone book under "Engines-Gasoline."

Find us fast in the



215-100AB2

GEAR CASE ASSEMBLY 717-0317

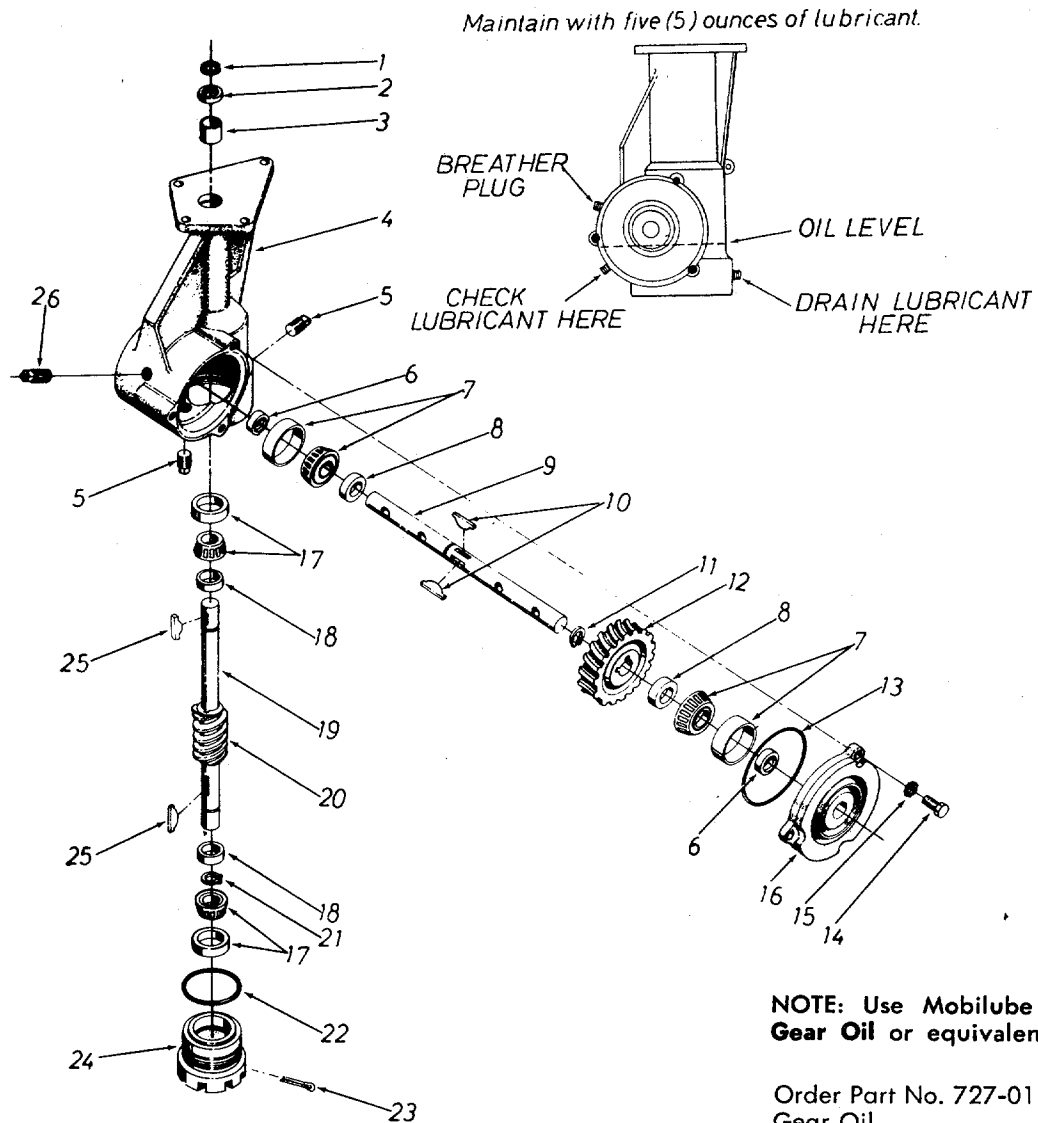

PARTS LIST FOR GEAR CASE ASSEMBLY 717-0317

REF. NO.	PART NO.	COLOR CODE	DESCRIPTION	NEW PART	REF. NO.	PART NO.	COLOR CODE	DESCRIPTION	NEW PART
1	716-0119		Snap Ring 3/4" Dia. Shaft		14	710-0371		Hex Scr. 5/16-18 x .88" Lg.	
2	721-0100		Oil Seal 3/4" Shaft		15	736-0119		L-Wash. 5/16" Scr.*	
3	748-0106		Sleeve Bearing .752" I.D.		16	717-0227		Bearing Cap—Bolton Type	
4	717-0226		Gear Case		17	741-0107		Roller Bearing 3/4" Bore	
5	737-0103		Sq. Hd. Pipe Plug 3/8" Thd.		18	711-0469		Spacer .755" I.D. x 1.265" O.D.	
6	721-0102		Oil Seal Double Lip 1" Shaft		19	738-0171		Worm Shaft	
7	741-0108		Roller Bearing 1" Bore		20	717-0312		Worm (Stencil "20")	
8	711-0131		Spacer 1.005" I.D. x 1.390" O.D.		21	716-0101		Snap Ring for .750" Dia. Shaft	
9	711-0133		Tine Shaft		22	735-0100		O-Ring 2.12 x 2.38	
10	714-0103		#91 Woodruff Key 1/4" x 3/4" Dia.		23	714-0474		Cotter Pin 1/8" Dia. x .75" Lg.*	
11	716-0102		Snap Ring for 1.00" Dia. Shaft		24	10583		Bearing Adjustment Cap	
12	717-0315		Worm Wheel (Stencil "20")		25	714-0126		#9 Hi-Pro Key 3/16 x 3/4" Dia.	
13	735-0101		O-Ring 3.62 x 3.88		26	737-0102		Sq. Hd. Pipe Plug with Vent 3/8" Thd.	

*For faster service, obtain standard nuts, bolts and washers locally. If these items cannot be obtained locally, order by part number and size, as shown on parts list.

TILLER DRIVE MECHANISM

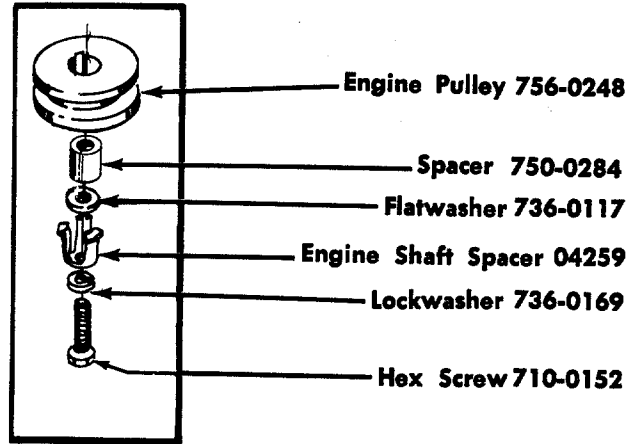

Engine Pulley Assembly

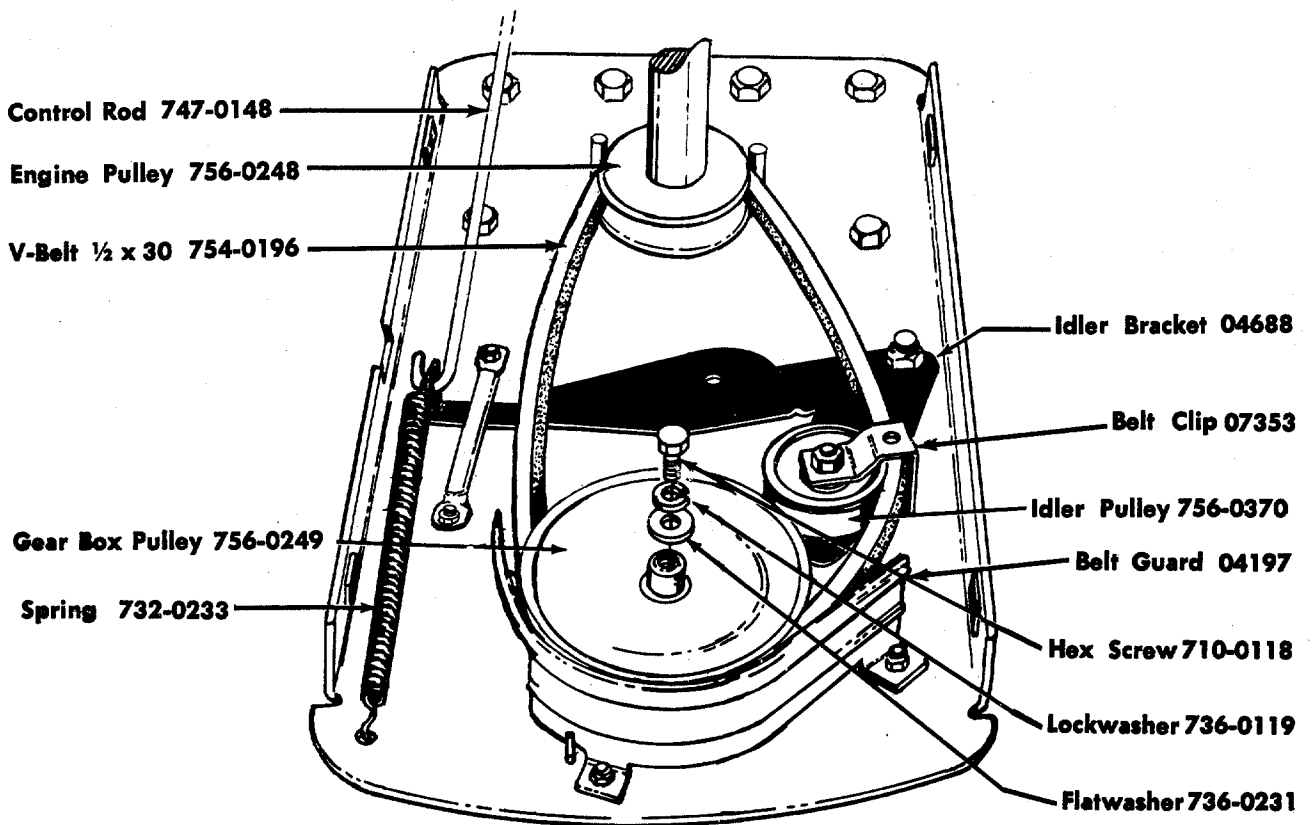

PARTS INFORMATION

DEFECTIVE OR MISSING PARTS must be reported to the factory immediately. Such claims must include your model number and date of purchase.

POWER EQUIPMENT PARTS AND SERVICE

Parts and service for all MTD manufactured power equipment are available through the authorized service firms listed below. All orders should specify the model number of your unit, parts numbers, description of parts and the quantity of each part required.

A 1 Engine & Mower Co.
327 East 9th Street
Salt Lake City, Utah 84102

Auto Electric & Carburetor Co.
2525 4th Avenue, S.
P. O. Box 1948
Birmingham, Alabama 35233

Automotive Equipment Service Co.
3117 Holmes Street
Kansas City, Missouri 64109

Bailey's Rebuild Inc.
1325 E. Madison Street
Seattle Washington 98102

Bleckrie, Inc.
7900 Lorain Avenue
Cleveland, Ohio 44102

Brown Equipment Distributor Inc.
110 Beech Street
Corydon, Indiana 47112

Bullard Supply
2409 Commerce Street
Houston, Texas 77003

Catto & Putty, Inc.
P. O. Box 2408
510 Soledad Street
San Antonio, Texas 78205

Center Supply Company
6867 New Hampshire Avenue
Takoma Park, Maryland 20012

Dixie Sales Company
P. O. Box 1408
327 Battleground Avenue
Greensboro, North Carolina 27402

East Point Cycle & Key Shop
1617 Whiteway
East Point, Georgia 30044

Gamble Distributors
West End Avenue
Carthage, New York 13619

Garden Equipment Co., Inc.
6600 Cherry Avenue
Long Beach, California 90805

Gardenville Supply, Inc.
Pipersville, Pennsylvania 18947

Henry W. O'Neil & Assoc., Inc.
410 North Goodman Street
Rochester, New York 14609

Henzler, Inc.
2015 Lemay Ferry Road
St. Louis, Missouri 63125

Kenton Supply
8216 North Denver Avenue
Portland, Oregon 97217

Kimber's Inc.
115 W. Geddes St.
Syracuse, New York 13204

Marr Brothers
423 E. Jefferson
Dallas, Texas 75203

McClure Lawn & Garden Supply
1114 Lexington Avenue
Mansfield, Ohio 44907

Memphis Cycle & Supply Co.
421 Monroe Avenue
Memphis Tennessee 38103

Morton B. Collins Co.
300 Birnie Avenue
Springfield, Massachusetts 01107

Moz-All of Florida, Inc.
365 Greco Avenue
Coral Gables, Florida 33146

National Central
687 Seville Rd.
Wadsworth, Ohio 44281

BRIGGS & STRATTON, TECUMSEH AND PEERLESS PARTS AND SERVICE

Briggs & Stratton, Tecumseh and Peerless parts and service should be handled by your nearest authorized engine service firm. Check the yellow pages of your telephone directory under the listing *Engines - Gasoline*, Briggs & Stratton or Tecumseh Lauson - Power Products.

Parts & Sales Inc.
2101 Industrial Pkwy.
Elkhart, Indiana 46514

Power Equipment Distributor
36463 So. Gratiot Avenue
Mt. Clemens, Michigan 48043

Power Lawn & Garden Equip. Co.
2551-2571 J. F. Kennedy Road
Dubuque, Iowa 52001

Radco Distributors
2403 Market Street
P. O. Box 3216
Jacksonville, Florida 32206

Raub Supply Company
James & Mulberry Sts.
Lancaster, Pennsylvania 17604

Richmond Battery & Ignition
P. O. Box 25369 - 957 Myers St.
Richmond, Virginia 23260

R. P. W., Inc.
623 S. 16th Street
Omaha, Nebraska 68102

Smith Hardware Company
515 N. George Street
Goldsboro, North Carolina 27530

South Denver Lawn Equip. Co.
527 West Evans
Denver, Colorado 80223

Suhren Engine
8330 Earhart Blvd.
New Orleans, Louisiana 70118

Sutton's Lawn Mower Shop
Route 4, Box 343
North Little Rock, Arkansas 72117

Woodson Sales & Service
1702 North Sylvania
Ft. Worth, Texas 76111

WARRANTY PARTS AND SERVICE POLICY

The purpose of warranty is to protect the customer from defects in workmanship and materials, defects which are NOT detected at the time of manufacture. It does not provide for the unlimited and unrestricted replacement of parts. Use and maintenance are the responsibility of the customer. The manufacturer cannot assume responsibility for conditions over which it has no control. Simply put, if it's the manufacturer's fault, it's the manufacturer's responsibility; if it's the customer's fault, it's the customer's responsibility.

CLAIMS AGAINST THE MANUFACTURER'S WARRANTY INCLUDES

1. Replacement of Missing Parts on new equipment.
2. Replacement of Defective Parts within the warranty period.
3. Repair of Defects within the warranty period.

All claims MUST be substantiated with the following information:

1. Model Number of unit involved.
2. Date unit was purchased or first put into service.
3. Date of failure.
4. Nature of failure.

Free Manuals Download Website

<http://myh66.com>

<http://usermanuals.us>

<http://www.somanuals.com>

<http://www.4manuals.cc>

<http://www.manual-lib.com>

<http://www.404manual.com>

<http://www.luxmanual.com>

<http://aubethermostatmanual.com>

Golf course search by state

<http://golfingnear.com>

Email search by domain

<http://emailbydomain.com>

Auto manuals search

<http://auto.somanuals.com>

TV manuals search

<http://tv.somanuals.com>