

# Owner's Operating Service Instruction Manual

10¢

**Model No.  
216-100A**

- ASSEMBLY
- OPERATION
- REPAIR PARTS

**VERTICAL ROTARY TILLER**

# SAFETY RULES

1. Your tiller is a precision piece of power equipment. Exercise extreme CAUTION at all times.
2. Do not attempt to start engine with the clutch control in the engaged or FORWARD position.
3. Stand clear of tines when starting engine. Never stand in front of, or work on tines while the engine is running.
4. NEVER place hands or feet in the vicinity of the tines while the engine is running.
5. Always stop engine when tiller is not in actual use.
6. Always disconnect spark plug wire during repairs or refueling operations.
7. Do not fill fuel tank while engine is running. Do not spill gasoline on hot engine.

Your rotary tiller is a precision built machine designed to take the work out of gardening and other related chores. It can be used for seed bed preparation, tilling, cultivating, furrowing, composting and mulching. Like any other piece of power equipment, it requires a certain amount of care and maintenance. In return for this, it will give a maximum of service and efficiency. Read these instructions carefully before assembling or operating your tiller. Through proper care and operation, you will obtain long, efficient service and trouble free operation.



## NOTE

Your tiller is shipped without oil in the engine crankcase. See engine manual for correct type and amount.

## ASSEMBLY — ONE PIECE HANDLE

Your rotary tiller is shipped complete in a single carton. The tines, wheels, handle and depth bar are to be assembled. This is done in the manner described below.

**Tines**—Mount tines on tine shaft as shown. (See page 8.) Tines must be mounted with the cutting edges facing the correct direction. The tiller will not operate properly unless the sharpened surface of the tines enter the soil first. Secure tines in position on tine shaft with cap screws (35), and nuts (24).



## NOTE

Dust pads (21 and 22) are provided in screw pack. Install dust pads as shown on page 8.

**Wheels** — Insert axle bolts (23) into wheel hubs. Place washers (26) between wheel and leg. Attach wheel and axle assemblies to outside of tiller legs (27) and (30). Secure with nuts (29) and lockwashers (28). Tighten securely. See page 6 for correct sequence of parts.

**Handle** — Assemble the handle brackets (8) to the handle (2) with hex head screw (11), lockwashers (9) and hex nuts (10). DO NOT tighten. Place the handle brackets (8) in the tailpiece slots. Line up lower holes in handle brackets with mounting holes in tailpiece assembly. Secure with carriage bolt 5/16-18 x 3/4" Lg. (20), lockwasher (13) and hex nut (12). Line up upper holes in handle brackets with mounting holes in mounting plate assemblies (19) and secure with carriage bolt (20), lockwasher (13) and hex nut (12). See page 6 for correct sequence. Tighten all nuts and bolts securely.

## CLUTCH CONTROL LEVER ASSEMBLY

**Clutch Lever**—Assemble in this order: rubber washer (42), steel washer (41), clutch lever assembly (43), (rod bracket to the front), steel washer (41) and lock nut (40). Tighten until rubber washer compresses slightly. (See page 6.)

**Clutch Control Assembly** — Screw the ferrule (37) on the threaded end of the control rod (38) until about 1/2" of the threads show above the ferrule. Insert the ferrule through the control pivot lever (36), fasten with flat washer (35) and cotter hairpin (34). Put the clutch handle in the neutral position. Insert the control rod in the bracket on the clutch lever and secure with a cotter hairpin (34) through the center of the bracket. Adjust the ferrule so the belt is slack when the clutch lever is in the neutral position. (See page 6.)

**Depth Bar** — Attach depth bar (18) in desired position with clevis pin (17) and locking pin (15). (See page 6.)

**Grips** — Slip hand grips on the upper end of each handle. They will slip on more easily if you first soak them in warm soapy water.

## CHECK LIST BEFORE OPERATION

1. Remove spark plug wire from spark plug and ground. Check tiller tines for proper installation. With throttle control lever set on STOP position and the clutch control handle set in FORWARD position, slowly crank engine to determine direction of tine rotation. Be sure all tines are mounted so the sharpened edges enter the soil first.
2. Now place the clutch control handle in NEUTRAL position. Slowly crank engine. The tines should not rotate.
3. Check all nuts and bolts for proper tightness. This is especially important during the initial operation period. Make this same check periodically thereafter.

4. Check gear case for proper lubricant level. With tiller on a level surface, lubricant level should be up to the front pipe plug opening. This can be checked by removing front pipe plug. Maintain correct lubricant level with Mobilube SAE 140 Gear Oil or equivalent. The gear case holds five (5) ounces of lubricant.
5. Fill fuel tank with clean, fresh, regular grade gasoline. This should be used at all times.
6. Check engine crankcase for proper oil level. The engine is shipped without oil in the crankcase. Be sure to fill crankcase before starting engine. Be sure crankcase is FULL. See engine manual for correct type and amount.



#### **NOTE**

The engine is warranted separately by the engine manufacturer. For warranty service contact the engine manufacturer or their local authorized service station. All important information pertaining to care and operation is included in the engine manual.

#### **STARTING YOUR TILLER**

1. Be sure clutch control handle is in NEUTRAL position.
2. Move throttle lever to START position on engine.
3. After cranking the engine several times or as the engine fires, move the throttle lever to RUN position.
4. Adjust throttle lever for desired operating speed.
5. To stop engine, move throttle lever to STOP position. Keep throttle lever in STOP position at all times when tiller is not in use.



#### **NOTE**

A brief break-in period is essential to insure maximum engine life. This consists of running the engine at half speed for a period of time required to use one tank of gasoline. This is necessary on the initial run only. It is also recommended that the oil be changed after five (5) hours of operation. This allows for the removal of impurities which may have accumulated during the break-in period. Subsequent oil changes should be made as stated in the engine manual. Always check oil before using your tiller. Be sure oil level is adequate.

#### **OPERATING INSTRUCTIONS**

For your own convenience and safety, observe all safety suggestions shown in this manual. Your tiller is not a toy, it is a precision piece of power equipment. Treat it as such.

It is important to recognize the fact that the forward and penetrating action of the rotary tiller is obtained from the rotating action of the tines in the soil. The depth bar acts as a brake for the tiller and controls the depth and speed at which the machine will operate. By lowering the setting of the depth bar, the forward speed of the machine is reduced and the working depth of the tines is increased. Raising the setting of the depth bar increases the forward speed and reduces the working depth. When soil conditions are severe and several passes must be made over a certain area, the depth bar setting should be lowered each time a pass is made. Further control of tilling depth and travel speed can be obtained by variation of pressure on the handles or the throttle setting. A downward pressure on the handles will increase the working depth and reduce the forward speed. An upward pressure on the handles will reduce the working depth and increase the forward speed. The type of soil and working conditions will determine the actual setting of the depth bar and the handle pressure required.

1. Tine engagement and forward travel is achieved by moving the clutch lever to FORWARD position. Tine rotation and forward motion are stopped by moving the clutch lever to NEUTRAL position.
2. The throttle lever adjusts the engine speed. It also gives fingertip control of the carburetor and magneto stop switch. When the throttle lever is pushed completely to the right from behind the tiller, the carburetor is in START position. Pulling the lever to the left reduces the engine speed to SLOW. When the lever is pulled completely to the left from behind the tiller, the magneto stop switch grounds out the spark and stops the engine.
3. When the depth bar is positioned out of ground engagement, self-propelled transporting of the tiller is easily achieved. With no pressure on the handles and the throttle lever set for SLOW engine speed, move the clutch control handle to the FORWARD position and let the tiller gently propel itself.

#### **ADJUSTMENTS**

**Belts**—Belt slack is taken up by a spring loaded idler pulley. Because of this, belt adjustment is not required.

**Clutch**—No adjustment of the lower clutch rod is required. This is done automatically by the spring loaded idler.

 **NOTE**

Belt and clutch adjustments can be made by moving the engine bed. Loosen the four bolts which secure it and move the engine bed forward or backward as required. Adjusting the control rod will also effect the belt and clutch adjustment. These adjustments may be necessary if handle position is changed.

**Handle**—The position of the handle may be adjusted by removing and moving carriage bolts to the desired mounting holes. Adjustment should be made for the most convenient operating height.

**Wheels**—Wheel positions may be varied to give further adjustment of handle height. Various wheel positions also give variations of the leverage and weight distribution over the tines. Wheels should be set to suit the local soil conditions and the operator's convenience.

**Tines**—The standard width of cut is 26". Because of the various types of work to which the tiller may be put, variation in the tilling widths may be necessary. This can be accomplished in a number of ways.

1. Standard tine arrangement ----- 26"
2. Remove tines that point outward from outer tine assemblies. Tines may be interchanged with opposite sides -----20"
3. Add tine extensions to standard arrangement (See page 5.) ----- 40"

 **NOTE**

When adjusting tines, be sure the cutting edges enter the soil first.

**MAINTENANCE AND LUBRICATION**

**Engine**—Service engine in accordance with the engine manufacturer's owner's guide.

 **NOTE**

To drain oil, remove oil filler plug and tip tiller on its side. Drain oil while the engine is warm. See engine manual for filling instructions.

**Gear Case**— Proper lubricant level should be up to the front pipe plug. Check with tiller on a level surface. Add enough to bring level up to front pipe plug hole. Use Mobilube SAE 140 Gear Oil or equivalent. Gear case should be maintained with five (5) ounces of lubricant.

**Belt** — Access to V belt and pulley assemblies is accomplished by removing the engine and engine bed as described below.

1. Remove four cap screws which secure engine bed to mounting plate assembly. Remove engine bed with engine attached.
2. Remove hex screw, lockwasher and flatwasher in 4½" pulley. Remove pulley and "V" belt. The belt clip on idler must be loosened to remove belt, mark correct location of belt clip in relation to idler before loosening. This can be done by scribing the belt clip and the end of the weld bolt in idler with a file. It is most important that this clip be reassembled in the right position.
3. Position new belt on 4½" pulley and reinstall on gear case shaft. Pulley must be mounted in position so that it will line up with engine pulley when assembly is completed. The correct position is that point at which the center of the pulley is 1½" above the mounting plate assembly. Tighten hex screw, lockwasher and flat washer securely.
4. Line up the belt clip in original position and tighten securely. Make sure belt is inside belt guards. While holding the belt taut (grasp at extreme rear position), move clutch belt lever to FORWARD and NEUTRAL position. If belt clip touches belt with lever in either position, readjust position of clip.
5. Move clutch lever to NEUTRAL position. Remove inspection plate from engine bed.
6. Replace engine bed on mounting plate assembly. Move engine bed and engine as far forward as possible.
7. Remove inspection plate (See page 8.) from engine bed and reach through inspection hole and guide belt into position on engine pulley.
8. Check visually through inspection hole to make sure belt is inside all belt guards and that pulleys are in proper alignment. A flashlight will help you make this check quickly and easily.
9. Line up mounting holes of engine bed and mounting plate then replace cap screws. Do not tighten cap screws until all four screws are in place. Replace inspection plate.

**REPLACING TILLER GEAR CASE OIL SEALS**

1. Drain lubricant.
2. Remove tine assemblies.
3. Remove bearing cap. (See reference 16 on page 10.)
4. Remove bearings, worm wheel and tine shaft. Do not remove bearing races.
5. Remove oil seals from gear case and bearing cap.
6. Remove all burrs from holes in tine shaft.

7. Dip oil seals in lubricant and then insert one in gear case and one in bearing cap.
8. Wipe tine shaft clean of filings and lubricate before assembling with bearings and worm wheel in gear case.
9. Replace bearing cap.



#### CAUTION

Do not damage oil seals. The open flanges face to the outside of the gear case.

10. Tighten bearing cap, retighten screws evenly.
11. Replace tine assemblies and add lubricant. (See page 4.)

**General**—Check periodically all nuts and bolts. Loose nuts and bolts can cause permanent damage to your unit. Keep all nuts and bolts securely tightened.

**Storage**—The following steps should be taken to prepare your tiller for storage.

1. Clean tiller thoroughly and lubricate as described in the preceding instructions.
2. Coat tilling tines with grease to prevent rusting.
3. Prepare engine for storage in accordance with engine manufacturer's owner's guide.
4. Block tiller legs to raise tires clear of floor. Be sure tiller is level.
5. Store in a dry, clean area.

#### **ATTACHMENTS**

**Extension Tines**—This attachment is available to increase your tilling width up to 40". Extension tines are easily installed and removed. Order under part number 296-162A.

**Furrow Opener**—This attachment is easily installed on the depth bar of your tiller. It can be used for either furrowing or hilling operations. These attachments are available through your local dealer.

For wide (2" x .43") depth bar, order furrow opener 296-179A.

# 216-100A

IF YOU WRITE TO US ABOUT THIS ARTICLE  
OR IF YOU ORDER REPLACEMENT PARTS AL-  
WAYS MENTION THIS MODEL & SERIAL NO  
MODEL

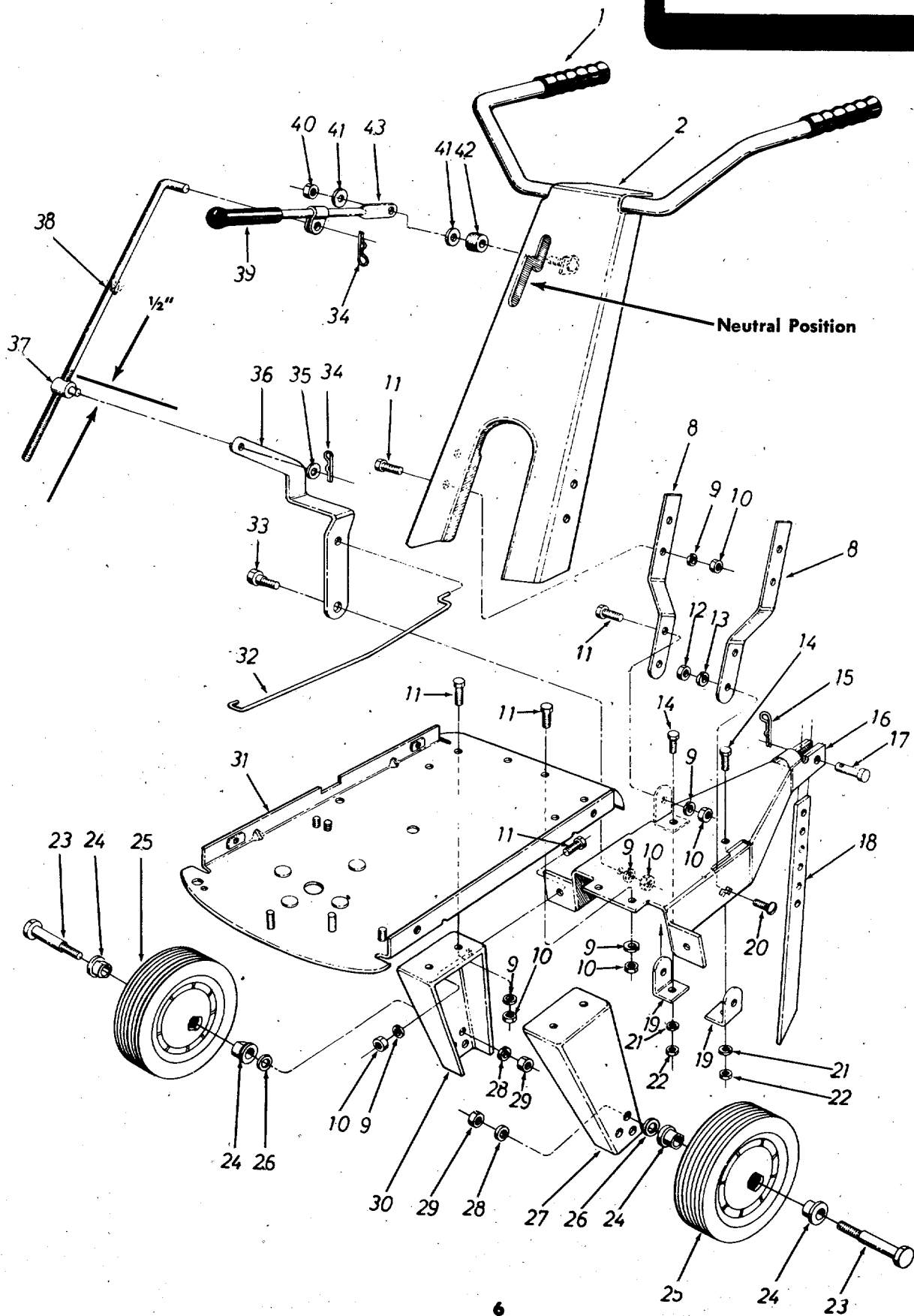

**PARTS LIST FOR MODEL 216-100A**

REF. NO.	PART NO.	COLOR CODE	DESCRIPTION	NEW PART	REF. NO.	PART NO.	COLOR CODE	DESCRIPTION	NEW PART
1	01166		Grip—Black		26	736-0253		Belleville Wash. .505 I.D. x 1.00 O.D.	
2	04624	—463	Handle Ass'y.						
8	04386	—463	Handle Mount Brackets		27	04109	—463	Leg—Left Hand	
9	736-0169		L-Wash. 3/8" Scr.*		28	736-0921		L-Wash. 1/2" Scr.*	
10	712-0798		Hex Nut 3/8-16 Thd.*		29	712-0206		Hex Nut 1/2-13 Thd.*	
11	710-0253		Hex Scr. 3/8-16 x 1.00" Lg.*		30	04110	—463	Leg—Right Hand	
12	712-0267		Hex Nut 5/16-18 Thd.*		31	04691	—463	Mounting Plate Ass'y.	
13	736-0119		L-Wash. 5/16" Scr.*		32	747-0148		Lower Control Rod	
14	710-0118		Hex Scr. 5/16-18 x .75" Lg.*		33	738-0183		Shoulder Scr. .500" Dia. x .215	
15	732-0194		Spring Pin						
16	04329	—463	Tail Piece Ass'y.		34	714-0115		Cotter Pin 1/8" Dia. x 1.00" Lg.*	
17	711-0231		Clevis Pin .500" Dia.						
18	04668	—463	Depth Bar		35	736-0204		FI-Wash. .344" I.D. x .62 O.D.	
19	04124	—463	Handle Mount Brackets		36	04619		Control Pivot Lever	
20	710-0276		Carriage Bolt 5/16-18 x 1.00" Lg.*		37	711-0392		Adjustment Ferrule	
					38	711-0502		Control Rod 20"	
21	736-0119		L-Wash. 5/16" Scr.*		39	720-0143		Grip—Black	
22	712-0267		Hex Nut 5/16-18 Thd.*		40	712-0158		Hex Inserted L-Nut 5/16-18 Thd.	
23	738-0240		Shoulder Scr. .625" Dia. x 2.75		41	736-0159		FI-Wash. .344 I.D. x .88 O.D.	
24	741-0116		Flange Brg. with Flats .631 I.D.		42	735-0126		Rubber Wash. .33 I.D. x .87 O.D.	
25	734-0585		Wheel Ass'y. 9.0 x 1.75		43	04392		Clutch Lever Ass'y.	

\*For faster service, obtain standard nuts, bolts and washers locally. If these items cannot be obtained locally, order by part number and size as shown on parts list.

(463—Top Flite Red) When ordering parts if color or finish is important, use the appropriate color code shown at left. (e.g. Top Flite Red Finish—04624 (463) )

The engine is not under warranty by the tiller manufacturer. If repairs or service is needed on the engine, please contact your nearest authorized engine service outlet. Check the "Yellow Pages" of your telephone book under "Engines-Gasoline."

Find us fast in the



# 216-100A

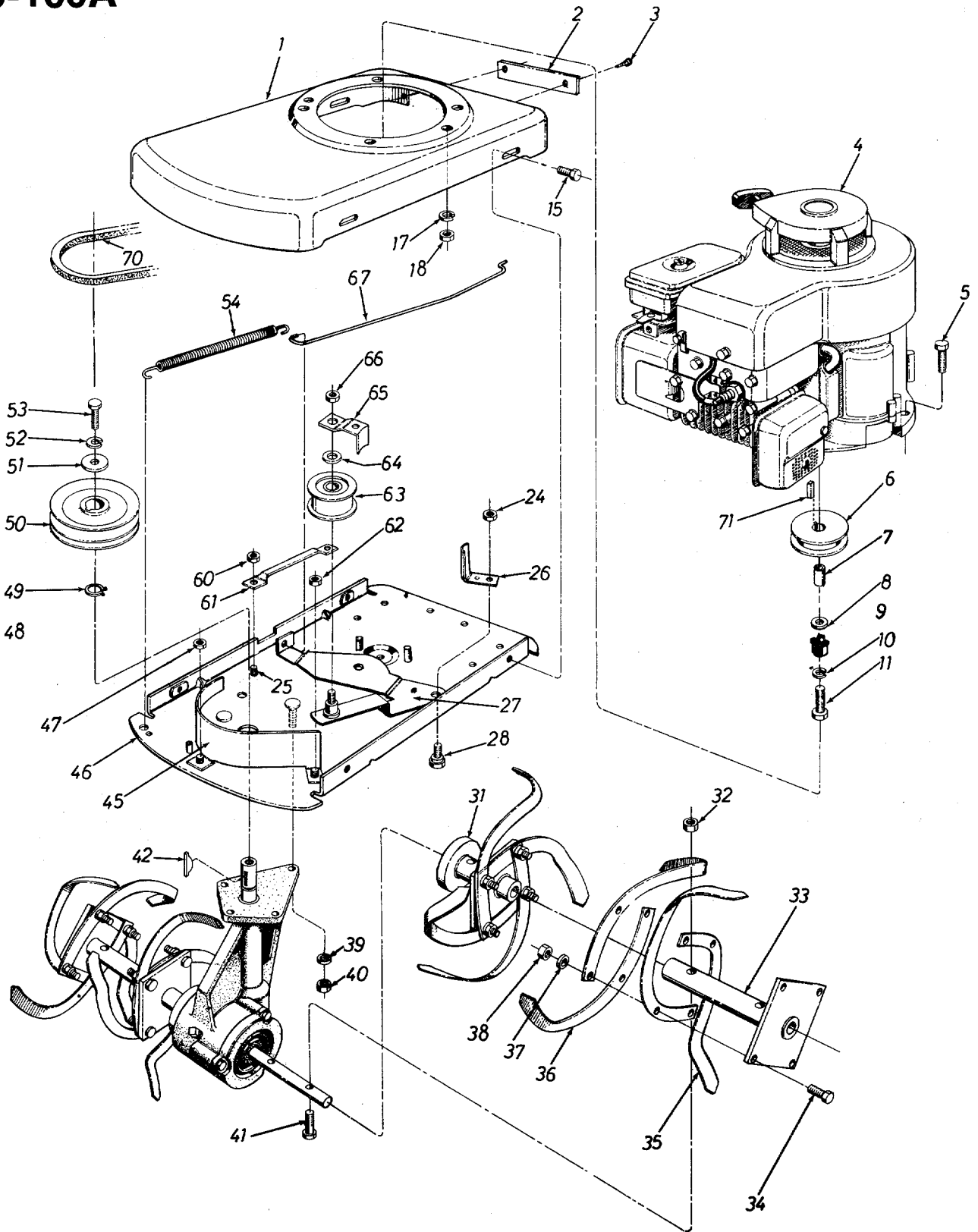

INNER TINE ASS'Y.—COMP.—L.H. 04701    Optional Tine  
 INNER TINE ASS'Y.—COMP.—R.H. 04702    Extension—Order  
 OUTER TINE ASS'Y.—COMP.—L.H. 04293    Part No. 296-162A  
 OUTER TINE ASS'Y.—COMP.—R.H. 04294    04673



**PARTS LIST FOR MODEL 216-100A**

REF. NO.	PART NO.	COLOR CODE	DESCRIPTION	NEW PART	REF. NO.	PART NO.	COLOR CODE	DESCRIPTION	NEW PART
1	04248	—312	Engine Bed		38	712-0241		Hex Nut 3/8-24 Thd. *	
2	04126		Inspection Plate		39	736-0169		L-Wash. 3/8" Scr. *	
3	710-0128		Hex F-Tapp Scr. #10-32 x .50" Lg. *		40	712-0798		Hex Nut 3/8-16 Thd. *	
4	—		Engine		41	710-0539		Hex Scr. 3/8-24 x 1.75" Lg. H.T.	
5	710-0158		Hex Scr. 5/16-24 x 1.25" Lg. *		42	714-0126		#9 Hi-Pro-Key 3/16 x 3/4" Dia.	
6	756-0248		Sheave 3.0" x .50		45	04197	—463	Belt Guard	
7	750-0284		Spacer		46	04691	—463	Mounting Plate Ass'y.	
8	736-0117		FI-Wash. .385" I.D. x .62 O.D.		47	712-0107		Hex Cent. L-Nut 1/4-20 Thd.	
9	04259		Engine Shaft Spacer		49	716-0119		Snap Ring 3/4" Dia. Shaft	
10	736-0169		L-Wash. 3/8" Scr. *		50	756-0249		Pulley—Double Groove 4.50" O.D.	
11	710-0152		Hex Scr. 3/8-24 x 1.00" Lg. *		51	736-0231		FI-Wash. .344 x 1.125	
15	710-0259		Hex Sems Scr. 5/16-18 x .62" Lg. *		52	736-0119		L-Wash. 5/16" Scr. *	
17	736-0119		L-Wash. 5/16" Scr. *		53	710-0118		Hex Scr. 5/16-18 x .75" Lg. *	
18	712-0123		Hex Nut 5/16-24 Thd. *		54	732-0233		Spring Extension .62 O.D. x 4.94 Lg.	
24	712-0181		Hex Top L-Nut 3/8-16 Thd. *		60	712-0107		Hex Cent. L-Nut 1/4-20 Thd.	
25	710-0600		Hex Wash.-Hd. Self Tapp. Scr. 5/16-24 x .50" Lg.		61	04196		Hold Down Clamp	
26	04204		Belt Pusher		62	712-0107		Hex Cent. L-Nut 1/4-20 Thd.	
27	04688		Idler Brkt. Ass'y.		63	756-0370		Idler Bearing Ass'y.	
28	738-0183		Shoulder Scr. .500" Dia. x .215		64	736-0300		FI-Wash. .385" I.D. x .870" O.D.	
31	04673		Inner Tine Adapter Ass'y.	N	65	07353		Belt Clip	
32	712-0116		Hex Center L-Nut 3/8-24 Thd.		66	712-0158		Hex Cent. L-Nut 5/16-18 Thd.	
33	04683		Outer Tine Adapter Ass'y.	N	67	747-0148		Lower Control Rod	
34	710-0191		Hex Scr. 3/8-24 x 1.25" Lg. *		70	754-0196		V-Belt 1/2" x 30" Lg. (Forward Belt) Fiber "B"	
35	742-0105		Tine 12"—Left Hand						
36	742-0106		Tine 12"—Right Hand		71	714-0105		Sq. Key 3/16 x 3/16 x 1.00" Lg.	
37	736-0169		L-Wash. 3/8" Scr. *						

\*For faster service, obtain standard nuts, bolts and washers locally. If these items cannot be obtained locally, order by part number and size as shown on parts list.

(463—Top Flite Red) When ordering parts if color or finish is important, use the appropriate color code shown at left. (e.g Top Flite Red Finish—04624 (463) )

The tiller is not under warranty by the tiller manufacturer. If repairs or service is needed on the engine, please contact your nearest authorized engine service outlet. Check the "Yellow Pages" of your telephone book under "Engines-Gasoline."

Find us fast in the



# 216-100A

## GEAR CASE ASSEMBLY 717-0305

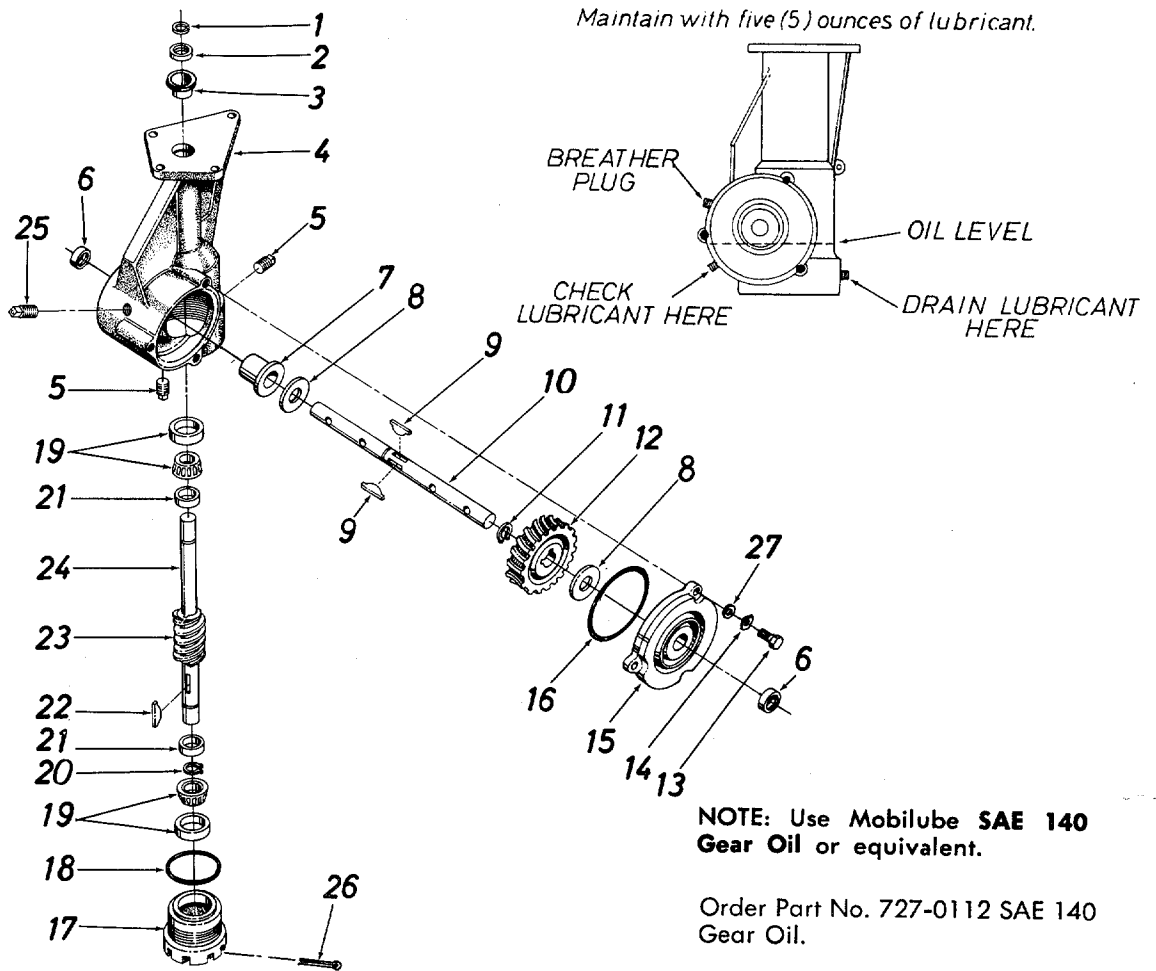

### PARTS LIST FOR GEAR CASE ASSEMBLY 717-0305

REF. NO.	PART NO.	COLOR CODE	DESCRIPTION	NEW PART	REF. NO.	PART NO.	COLOR CODE	DESCRIPTION	NEW PART
1	716-0119		Snap Ring .75" Dia. Shaft		14	736-0271		Shakeproof Spring Wash. 5/16" Scr.	
2	721-0100		Oil Seal .75" Dia. Shaft		15	741-0188		Bearing Cap with Bearing	N
3	741-0197		Sleeve Brg. .752 I.D. x .878 O.D. x 1.00" Lg.	N	16	735-0101		"O"-Ring 3.62" I.D. x 3.88 O.D. x .12	N
4	719-0223		Gear Case	N	17	10583		Bearing Adjustment Cap	
5	737-0102		Sq. Hd. Pipe Plug with Vent		18	735-0100		"O"-Ring 2.12 I.D. x 2.28 O.D. x .12	
6	721-0102		Oil Seal Double Lip 1.00" Shaft		19	741-0107		Roller Bearing Ass'y. .75 I.D.	
7	741-0189		Flange Brg. 1.00 I.D.	N	20	716-0101		Snap Ring for .75" Dia. Shaft	
8	736-0259		Fl-Wash. 1.00" I.D. x 1.62 O.D. x .095		21	711-0469		Spacer .755 I.D. x 1.265 O.D. x .502	
9	714-0103		#91 Woodruff Key 1/4 x 3/4" Dia.		22	714-0126		#9 Hi-Pro-Key 3/16 x .75" Dia.	
10	711-0622		Tine Shaft 1.00" Dia.	N	23	717-0312		Worm	
11	716-0102		Snap Ring for 1.00" Dia. Shaft		24	738-0171		Worm Shaft	
12	717-0311		Worm Wheel	N	25	737-0103		Sq. Hd. Pipe Plug 3/8" Thd.*	
13	710-0371		Hex Scr. 5/16-18 x .88" Lg. (Plastic Insert)		26	714-0474		Cotter Pin 1/8" Dia. x .75" Lg.*	
					27	736-0159		Fl.-Wash. 5/16" I.D.	

\*For faster service, obtain standard nuts, bolts and washers locally. If these items cannot be obtained locally, order by part number and size, as shown on parts list.

# 216-100A TILLER DRIVE MECHANISM

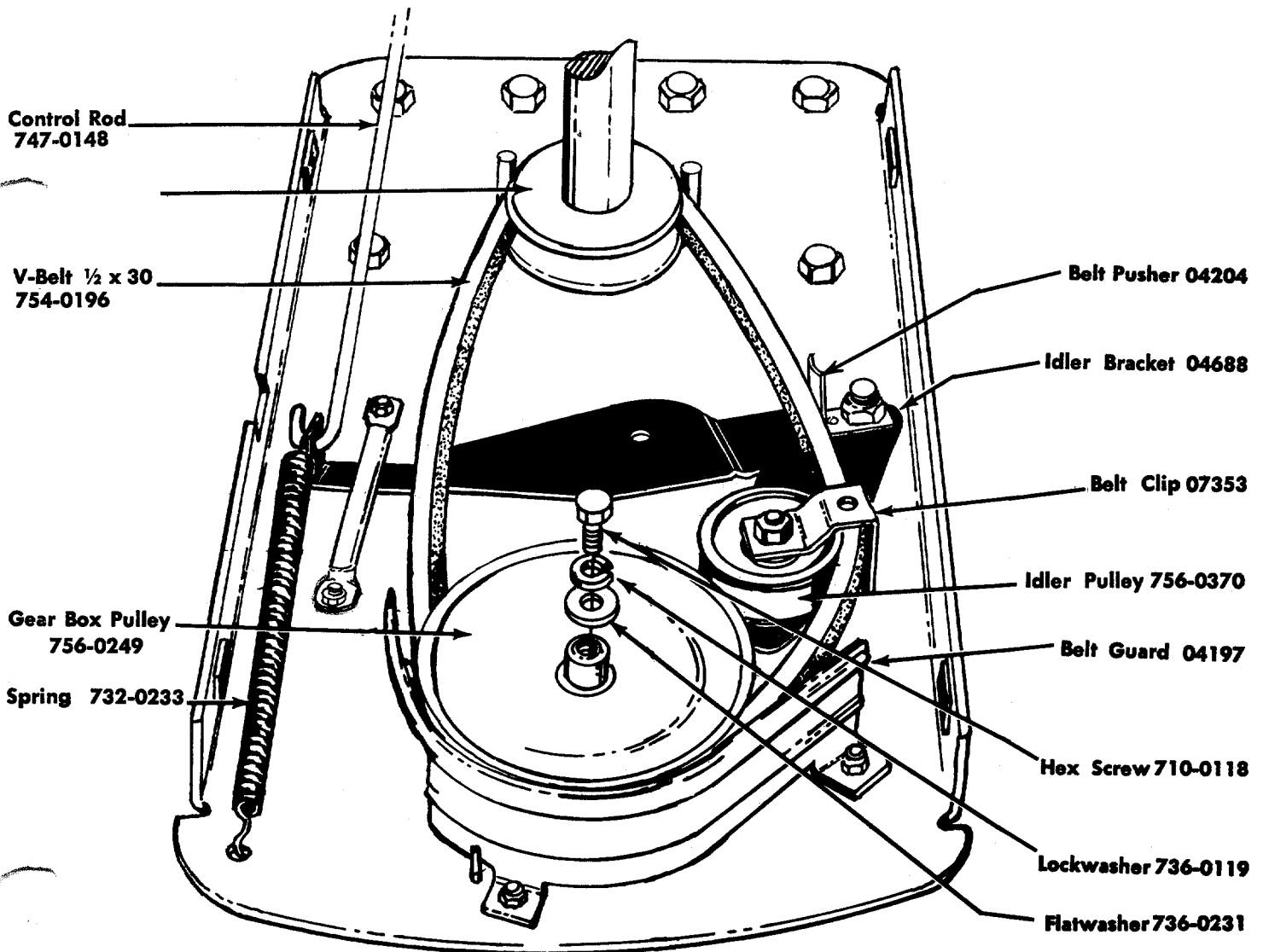
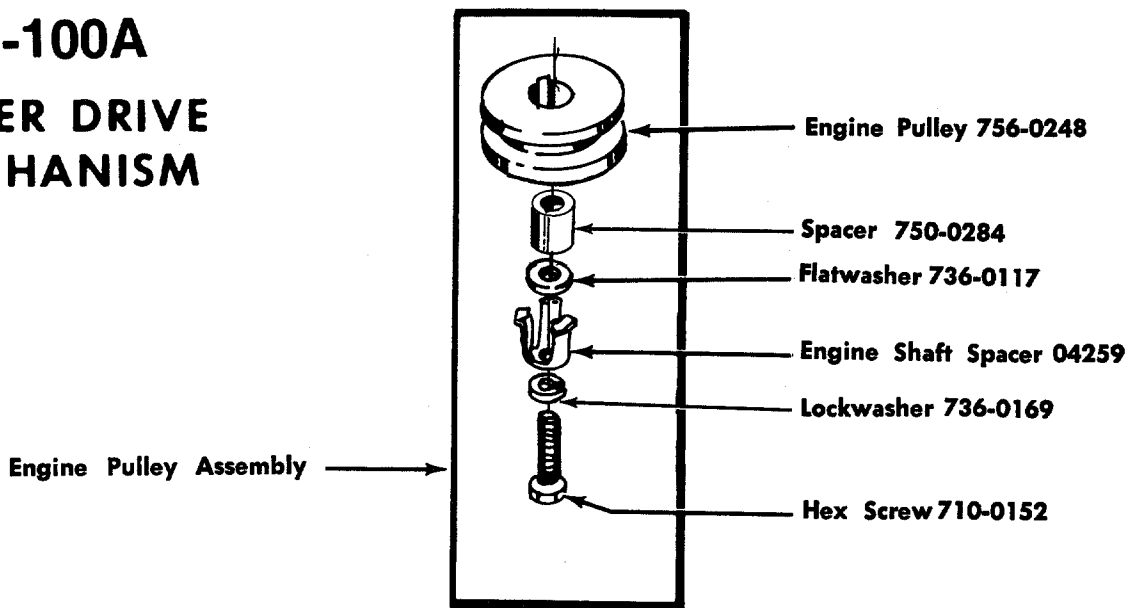

# PARTS INFORMATION

## POWER EQUIPMENT PARTS AND SERVICE

Parts and service for all MTD manufactured power equipment are available through the authorized service firms listed below. All orders should specify the model number of your unit, parts numbers, description of parts and the quantity of each part required.

<b>ALABAMA</b>	<b>BIRMINGHAM</b>	
	Auto Electric & Carburetor Co...	2625 4th Ave. S. .... 35233
<b>ARKANSAS</b>	<b>NORTH LITTLE ROCK</b>	
	Sutton's Lawn Mower Shop .....	Rt. 4, Box 368 ..... 72117
	<b>FORT SMITH</b>	
	Mity Mite Motors, Inc. ....	2515 Towson Ave. .... 72901
<b>CALIFORNIA</b>	<b>SAN BERNARDINO</b>	
	Lawn Mower Supply Co. ....	25608 E. Baseline .... 92410
	<b>SAN FRANCISCO</b>	
	J.W. Jewett Co. ....	981 Folsom St. .... 94107
	<b>SACRAMENTO</b>	
	Luttig & Severson .....	2030 28th St. .... 95818
<b>COLORADO</b>	<b>DENVER</b>	
	South Denver Lawn Equip. ....	527 West Evans ..... 80223
<b>CONNECTICUT</b>	<b>SUFFIELD</b>	
	The Jones & Ramsey Co. ....	850 Thompsonville Rd. 06078
<b>FLORIDA</b>	<b>JACKSONVILLE</b>	
	Radco Distributors .....	2403 Market St. .... 32206
	<b>CORAL GABLES</b>	
	Moz-All of Florida, Inc. ....	365 Greco Ave. .... 33146
<b>GEORGIA</b>	<b>EAST POINT</b>	
	East Point Cycle & Key .....	2834 Church St. .... 30344
<b>ILLINOIS</b>	<b>LYONS</b>	
	Keen Edge Co. ....	8615 Ogden Ave. .... 60534
<b>INDIANA</b>	<b>ELKHART</b>	
	Parts & Sales Inc. ....	2101 Industrial Pkwy. ...46514
	<b>CORYDON</b>	
	Brown Equip. Dist., Inc. ....	110 Beech St. ....47112
<b>IOWA</b>	<b>DUBUQUE</b>	
	Power Lawn & Garden Equip. ....	2551 J.F. Kennedy .... 52001
<b>KANSAS</b>	<b>WICHITA</b>	
	Hixon, Inc. ....	3030 Mascot ..... 67204
<b>LOUISIANA</b>	<b>NEW ORLEANS</b>	
	Suhren Engine Co. ....	8330 Earhart Blvd. .... 70118
<b>MARYLAND</b>	<b>TAKOMA PARK</b>	
	Center Supply Co. ....	6867 New Hampshire Ave. 20012
<b>MASSACHUSETTS</b>	<b>SPRINGFIELD</b>	
	Morton B. Collins Co. ....	300 Birnie Ave. .... 01107
<b>MICHIGAN</b>	<b>MOUNT CLEMENS</b>	
	Power Equipment Dist. ....	36463 South Gratiot... 48043
	<b>LANSING</b>	
	Lorenz Service Co. ....	2500 S. Pennsylvania.. 48900
<b>MINNESOTA</b>	<b>MINNETONKA</b>	
	Hance Distributing Inc. ....	11212 Wayzata Blvd. ...55343
<b>MISSISSIPPI</b>	<b>BILOXI</b>	
	Biloxi Sales & Service, Inc. ....	506 Caillavet St. .... 39533
<b>MISSOURI</b>	<b>KANSAS CITY</b>	
	Automotive Equip. Service .....	3117 Holmes St. .... 64109
	<b>ST. LOUIS</b>	
	Henzler, Inc. ....	2015 Lemay Ferry Rd. 63125
<b>NEBRASKA</b>	<b>OMAHA</b>	
	R.P.W., Inc. ....	7402 "L" St. .... 68127

## BRIGGS & STRATTON, TECUMSEH AND PEERLESS PARTS AND SERVICE

Briggs & Stratton, Tecumseh and Peerless parts a service should be handled by your nearest authorized engine service firm. Check the yellow pages of your telephone directory under the listing *Engines Gasoline*, Briggs & Stratton or Tecumseh Lauson

<b>NEW YORK</b>	<b>CARTHAGE</b>	
	Gamble Dist., Inc. ....	West End Ave. .... 13619
	<b>SYRACUSE</b>	
	Kimber's, Inc. ....	115 N. Geddes St. .... 13204
	<b>ROCHESTER</b>	
	Henry W. O'Neil & Associates .....	410 N. Goodman St. ... 14609
<b>NORTH CAROLINA</b>	<b>GREENSBORO</b>	
	Dixie Sales Company .....	327 Battleground Ave.. 27402
	<b>GOLDSBORO</b>	
	Smith Hardware Co. ....	515 N. George St. .... 27530
<b>OHIO</b>	<b>WADSWORTH</b>	
	National Central .....	687 Seville Rd. .... 44281
	<b>CLEVELAND</b>	
	Bleckrie, Inc. ....	7900 Lorain Ave. .... 44102
	<b>CARROL</b>	
	Stebe's Mid-State Mower Supply Box 366 .....	43112
	<b>WILLARD</b>	
	Sunshine Wholesale Tire Outlet Route 224 .....	44890
	<b>MANSFIELD</b>	
	McClure Lawn & Garden Supply...1114 Lexington Ave. .	44903
<b>OKLAHOMA</b>	<b>MUSKOGEE</b>	
	Victory Motors, Inc. ....	605 S. Cherokee ..... 74401
	<b>ADA</b>	
	Ada Auto Supply .....	301 E. 12th St. .... 74820
<b>OREGON</b>	<b>PORTLAND</b>	
	Kenton Supply Co. ....	8216 N. Denver Ave. . 97217
<b>PENNSYLVANIA</b>	<b>LANCASTER</b>	
	Raub Supply Co. ....	James & Mulberry Sts...17604
	<b>PITTSBURGH</b>	
	Bluemont Co. ....	1125 Frankstown Rd.. 152
<b>TENNESSEE</b>	<b>KNOXVILLE</b>	
	Master Repair Service .....	2423 Broadway, N.E. ...37917
	<b>MEMPHIS</b>	
	Memphis Cycle & Supply Co. ....	421 Monroe Ave. .... 38103
	American Sales & Service, Inc. .	1922 Lynnbrook ..... 38117
<b>TEXAS</b>	<b>DALLAS</b>	
	Marr Brothers, Inc. ....	423 E. Jefferson ..... 75203
	<b>HOUSTON</b>	
	Bullard Supply Co. ....	2409 Commerce St. .... 77003
	<b>SAN ANTONIO</b>	
	Catto & Putty, Inc. ....	P.O. Box 2408 .....78206
	<b>FORT WORTH</b>	
	Woodson Sales Corp. ....	1702 N. Sylvania ..... 76111
<b>UTAH</b>	<b>SALT LAKE CITY</b>	
	A-1 Engine & Mower Co. ....	437 E. 9th St. ....84111
<b>VERMONT</b>	<b>BURLINGTON</b>	
	Vermont Appliance Co. ....	44 Lakeside Ave. ....05401
<b>VIRGINIA</b>	<b>RICHMOND</b>	
	RBI Corp. ....	963 Myers St. .... 23260
<b>WASHINGTON</b>	<b>SEATTLE</b>	
	Bailey's Rebuild, Inc. ....	1325 E. Madison St. ...98102
<b>WEST VIRGINIA</b>	<b>CHARLESTON</b>	
	Young's, Inc. ....	233 Virginia St., E. ... 25301
<b>WISCONSIN</b>	<b>APPLETON</b>	
	Automotive Supply Co. ....	123 S. Linwood Ave. ...54911

## WARRANTY PARTS AND SERVICE POLICY

The purpose of warranty is to protect the customer from defects in workmanship and materials, defects which are NOT detected at the time of manufacture, it does not provide for the unlimited and unrestricted replacement of parts. Use and maintenance are the responsibility of the customer. The manufacturer cannot assume responsibility for conditions over which it has no control. Simply put, if it's the manufacturer's fault, it's the manufacturer's responsibility; if it's the customer's fault, it's the customer's responsibility.

### CLAIMS AGAINST THE MANUFACTURER'S WARRANTY INCLUDES

1. Replacement of Missing Parts on new equipment.
2. Replacement of Defective Parts within the warranty period.
3. Repair of Defects within the warranty period.

All claims MUST be substantiated with the following information:

1. Model Number of unit involved.
2. Date unit was purchased or first put into service.
3. Date of failure.
4. Nature of failure.

## Free Manuals Download Website

<http://myh66.com>

<http://usermanuals.us>

<http://www.somanuals.com>

<http://www.4manuals.cc>

<http://www.manual-lib.com>

<http://www.404manual.com>

<http://www.luxmanual.com>

<http://aubethermostatmanual.com>

Golf course search by state

<http://golfingnear.com>

Email search by domain

<http://emailbydomain.com>

Auto manuals search

<http://auto.somanuals.com>

TV manuals search

<http://tv.somanuals.com>