

OWNER'S GUIDE

OUTDOOR POWER EQUIPMENT
for all seasons

Spring

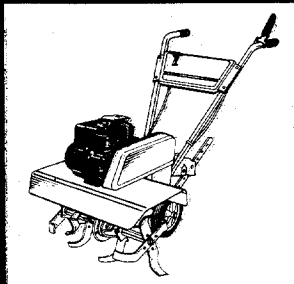

Summer

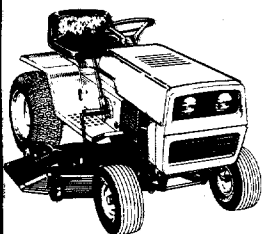

Fall

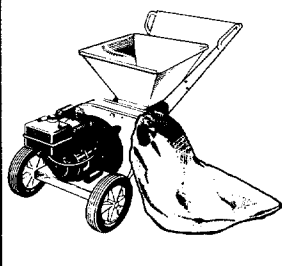

Winter

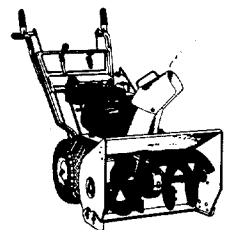

CHAIN DRIVE TILLER

Model Number
216-310-000

Important:
Read Safety Rules and
Instructions Carefully

Thank you for purchasing
an American-built product.

INDEX

Safe Operation Practices	3	Off-Season Storage	14
Assembly Instructions	4	Trouble Shooting Chart	15
Operation	10	Illustrated Parts	16, 18
How to Use Your Tiller	11	Parts Lists	17, 19
Adjustments	13	Parts for Chain Case	20
Lubrication	13	Parts Information	Back Cover
Maintenance	13		



Instructions given with this symbol are for personal safety. Be sure to follow them.

LIMITED WARRANTY

For one year from the date of original retail purchase, MTD PRODUCTS INC will either repair or replace, at its option, free of charge, F.O.B. factory or authorized service firm, any part or parts found to be defective in material or workmanship. Transportation charges for the movement of any power equipment unit or attachment are the responsibility of the purchaser. Transportation charges for any parts submitted for replacement under this warranty must be paid by the purchaser unless such return is requested by MTD PRODUCTS INC.

This warranty will not apply to any part which has become inoperative due to misuse, excessive use, accident, neglect, improper maintenance, alterations, or unless the unit has been operated and maintained in accordance with the instructions furnished. This warranty does not apply to the engine, motor, battery, battery charger or component parts thereof. Please refer to the applicable manufacturer's warranty on these items.

This warranty will not apply where the unit has been used commercially.

Warranty service is available through your local authorized service dealer or distributor. If you do not know the dealer or distributor in your area, please write to the Customer Service Department of MTD.

The return of a complete unit will not be accepted by the factory unless prior written permission has been extended by MTD.

This warranty gives you specific legal rights. You may also have other rights which vary from state to state.



WARNING

This unit is equipped with an internal combustion engine and should not be used on or near any unimproved forest-covered, brush-covered or grass-covered land unless the engine's exhaust system is equipped with a spark arrester meeting applicable local or state laws (if any). If a spark arrester is used, it should be maintained in effective working order by the operator.

In the State of California the above is required by law (Section 4442 of the California Public Resources Code). Other states may have similar laws. Federal laws apply on federal lands. A spark arrester muffler is available at your nearest engine authorized service center.



To reduce the potential for any injury, comply with the following safety instructions. Failure to comply with the instructions may result in personal injury.

SAFE OPERATION PRACTICES FOR TILLERS

1. It is suggested that this manual be read in its entirety before attempting to assemble or operate this unit. Keep this manual in a safe place for future and regular reference and for ordering replacement parts.
2. Your tiller is a precision piece of power equipment, not a plaything. Therefore, exercise extreme caution at all times.
3. Read this Owner's Manual carefully. Be thoroughly familiar with the controls and the proper use of the equipment.
4. Never allow children to operate a power tiller. Only persons well acquainted with these rules of safe operation should be allowed to use your tiller.
5. No one should operate this unit while intoxicated or while taking medication that impairs the senses or reactions.
6. Keep the area of operation clear of all persons, particularly small children and pets.
7. Do not operate equipment when barefoot or wearing open sandals. Always wear substantial footwear.
8. Do not wear loose fitting clothing that could get caught on the tiller.
9. Do not start the engine unless the shift lever is in the neutral (N) position.
10. Do not stand in front of the tiller while starting the engine.
11. Do not place feet and hands on or near the tines when starting the engine or while the engine is running.
12. Never attempt to make a wheel or depth bar adjustment while the engine is running.
13. Do not leave the tiller unattended with the engine running.
14. Do not walk in front of the tiller while the engine is running.
15. Check the fuel before starting the engine. Gasoline is an extremely flammable fuel. Do not fill gasoline tank indoors, while the engine is running, or while the engine is still hot. Replace gasoline cap securely, and wipe off any spilled gasoline before starting the engine as it may cause a fire or explosion.
16. Do not run the engine while indoors. Exhaust gases are deadly poisonous.
17. Be careful not to touch the muffler after the engine has been running. It is hot.
18. Do not change the engine governor settings or overspeed the engine. Excessive engine speeds are dangerous.
19. Before any maintenance work is performed or adjustments are made, remove the spark plug wire and ground it on the engine block for added safety.
20. Use caution when tilling near buildings and fences. Rotating tines can cause damage or injury.
21. Before attempting to remove rocks, bricks and other objects from tines, stop the engine and be sure the tines have stopped completely. Disconnect the spark plug wire and ground to prevent accidental starting.
22. Check the tine and engine mounting bolts at frequent intervals for proper tightness.
23. Keep all nuts, bolts and screws tight to be sure the equipment is in safe working condition.
24. Never store the equipment with gasoline in the tank inside of a building where fumes may reach an open flame or spark. Allow the engine to cool before storing in any enclosure.

NOTE

Reference to left or right side of the tiller is determined from behind the unit in the operating position.

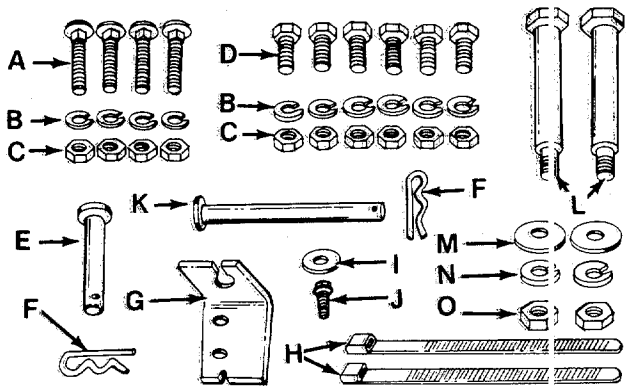

FIGURE 1.

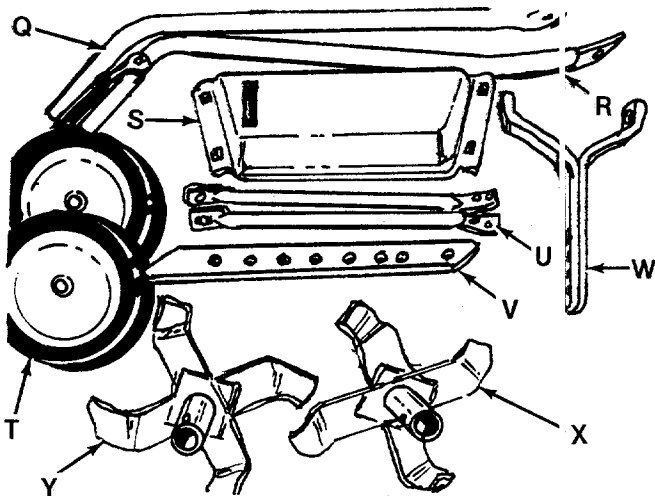

FIGURE 2.

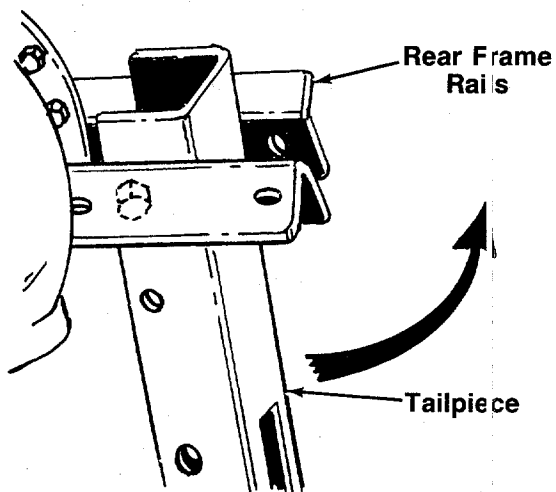

FIGURE 3.

ASSEMBLY INSTRUCTIONS

NOTE

This unit is shipped WITHOUT GASOLINE or OIL. After assembly, see operating section of this manual for proper fuel and engine oil recommendations.

Tools Required:

- (2) 1/2" Wrenches
- (1) 3/4" Wrench
- (1) Adjustable Wrench

Contents of Hardware Pack: (See Figure 1)

- A (4) Carriage Bolts 5/16-18 x 1 3/4" Long
- B (10) Lock Washers 5/16" I.D.
- C (10) Hex Nuts 5/16-18 Thread
- D (6) Hex Bolts 5/16-18 x 3/4" Long
- E (1) Clevis Pin 1/2" x 2 1/2" Long
- F (2) Hairpin Cotter
- G (1) Clutch Cable Support Bracket
- H (2) Cable Ties
- I (1) Flat Washer
- J (1) Self-Tapping Screw
- K (1) Clevis Pin 3/8" x 2 1/2" Long
- L (2) Shoulder Bolts (Axles)
- M (2) Belleville Washers
- N (2) Lock Washers 1/2" I.D.
- O (2) Hex Nuts 1/2-20 Thread
- P (2) Grips (Not Shown)
- Self-Tapping Screw #10 x .50" Long (Not Shown)

Loose Parts in Carton: (See Figure 2)

- Q (1) Right Hand Handle
- R (1) Left Hand Handle
- S (1) Handle Panel
- T (2) Wheels
- U (2) Handle Braces (Right & Left Hand)
- V (1) Depth Bar
- W (1) Wheel Yoke Assembly
- X (1) Right Hand Tine Assembly
- Y (1) Left Hand Tine Assembly

1. Remove the tiller, all loose parts and literature from the carton before discarding carton.
2. Extend the throttle control and place on the floor. Be careful not to bend or kink control wire.
3. The tailpiece is partially assembled. Pivot the tailpiece upward until the holes line up with the rear frame rails. See figure 3.

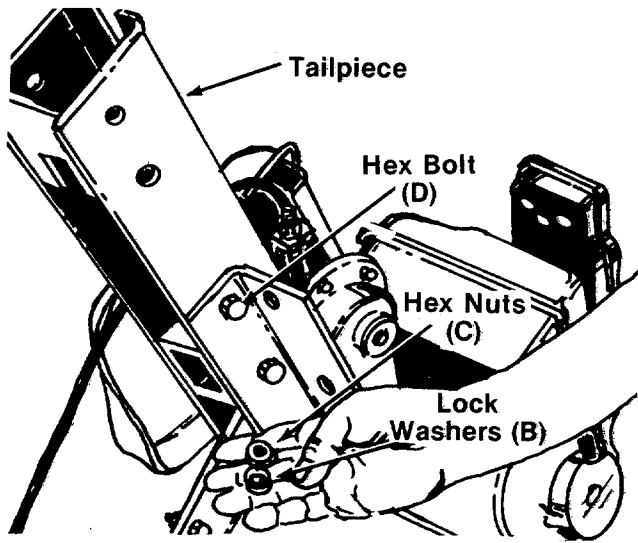

FIGURE 4.

4. Secure the tailpiece to the rear frame rails with two hex bolts (D), lock washers (B) and hex nutx (C). See figure 4. Tighten all four hex bolts and nuts securely. Two 1/2" wrenches are required.

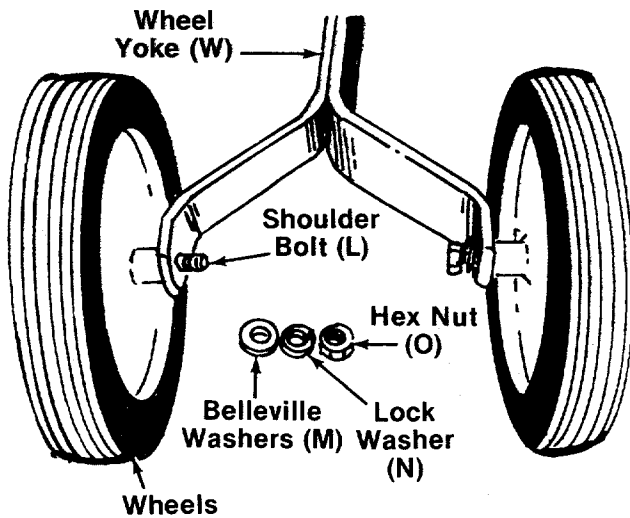

FIGURE 5.

5. Assemble wheels (T) to wheel yoke (W) with shoulder bolts (L), belleville washers (M) (cupped side of washer is against the wheel yoke), lock washers (N) and hex nuts (O) as shown in figure 5. A 3/4" wrench and an adjustable wrench is required.

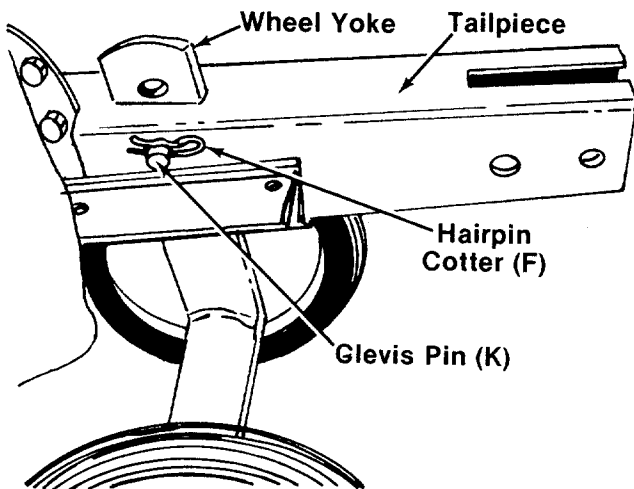
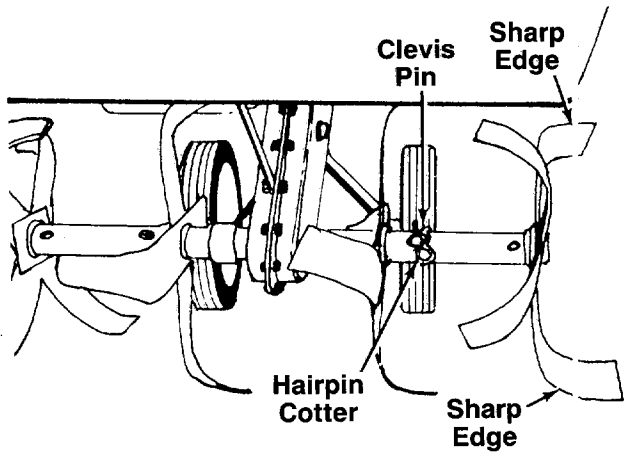

FIGURE 6.

6. Place the end of the wheel yoke up through the rectangular hole in the tailpiece. Secure with clevis pin (K) and hairpin cotter (F). See figure 6.



7. Remove the clevis pin and hairpin cotter from the inner tine assemblies as shown in figure 7. Place the right and left hand tine assemblies in position on tine shaft. Secure with clevis pins and hairpin cotters.

NOTE

Be certain the tine assemblies are assembled on the tine shaft so that the sharp edge of the tines enter the soil first. See figure 7.

FIGURE 7.

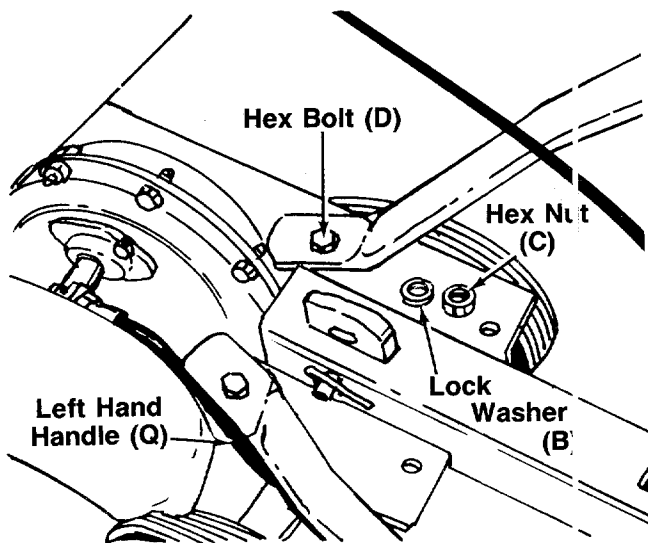

8. The left handle has a clutch grip already assembled to it. Assemble the left and right hand handles (Q and R) to the rear tiller frame as shown in figure 8. Secure with hex bolts (D), lock washers (B) and hex nuts (C), finger tight only (do not tighten).

FIGURE 8.

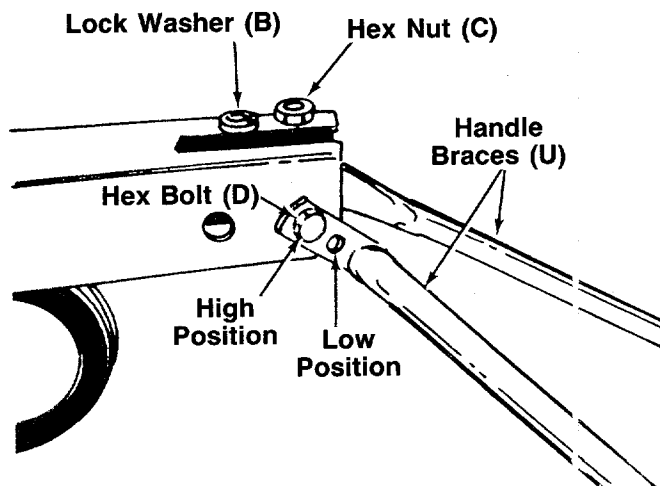

9. Attach the right and left hand braces (U) to the tailpiece. The braces have two holes to provide handle height adjustment. Select hole for either high or low position. Secure to tailpiece with hex bolts (D), lock washers (B) and hex nuts (C), finger tight only (do not tighten). See figure 9.

FIGURE 9.

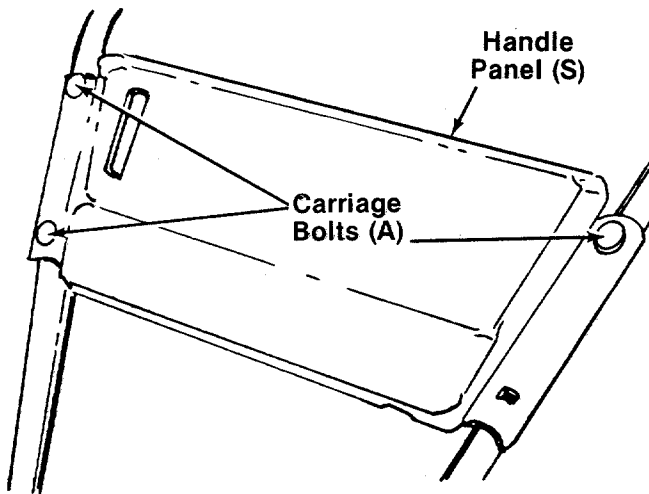

FIGURE 10.

10. Place the handle panel (S) in position on the handles. Secure the upper holes in the panel to the handles with carriage bolts (A), lock washers (B) and hex nuts (C), finger tight only. See figure 10.

11. Place carriage bolt (A) through the handle panel, handle and handle brace on the lower right hand side of the handle panel, finger tight only. See figure 10.

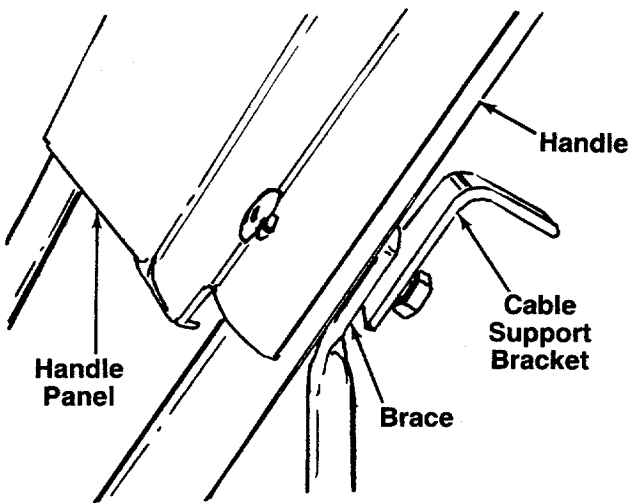

FIGURE 11.

12. Place carriage bolt (A) through the handle panel, handle, handle brace and cable support bracket on the lower left hand side of handle panel as shown in figure 11. Use the bottom hole in the cable support bracket. Secure with lock washer and hex nut, finger tight only.

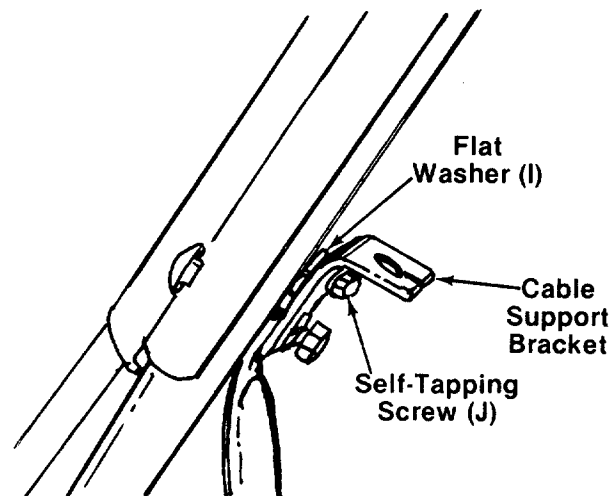

FIGURE 12.

13. Place flat washer (I) between handle and upper hole on cable support bracket. Secure with self-tapping screw (J). See figure 12.

14. Now tighten securely the self-tapping screw and all nuts and bolts on handles and braces.

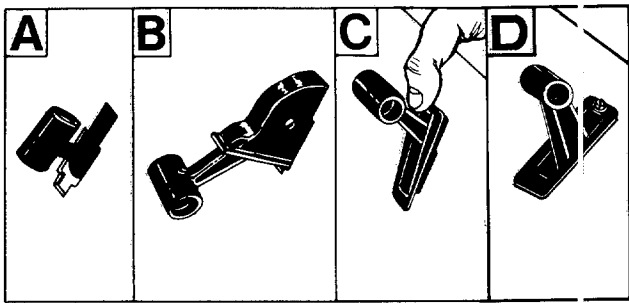

FIGURE 13.

15. Assemble the throttle control to the handle panel as follows.

- A. Hold the throttle control assembly beneath the handle panel. Turn the control sideways and insert the lever up through the wide portion of the slot on the handle panel. See figure 13A.
- B. After the end of the lever is through the slot, turn and then tip the control forward as shown in figure 13B to slide it through the slot.

NOTE

The lever must be all the way to the back of the control housing as shown in figure 13B.

- C. Push the control back into the slot in the handle panel and press in place. Be certain the control is locked securely into the slot. See figure 13C.

- D. Secure the throttle control to the handle panel using self-tapping screw provided. See figure 13D.

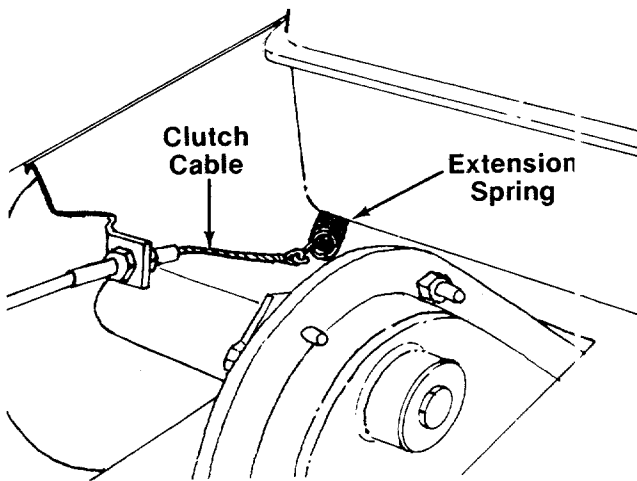

FIGURE 14.

16. Hook the end of the clutch cable (already attached to the tiller) over the extension spring as shown in figure 14.

NOTE

If spring has come loose, it must be reassembled to the weld pin on the idler bracket.

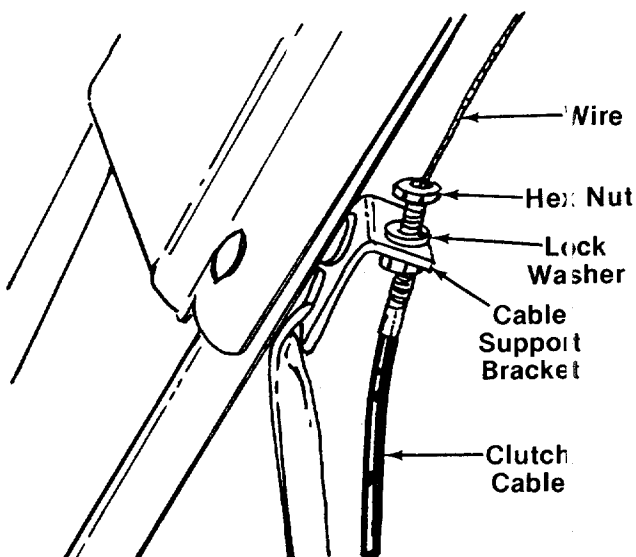

FIGURE 15.

17. Remove one nut and lock washer from other end of clutch cable. Slip the wire up through slot on cable support bracket. Start hex nut and lock washer back on end of clutch cable. See figure 15. Do not tighten at this time.

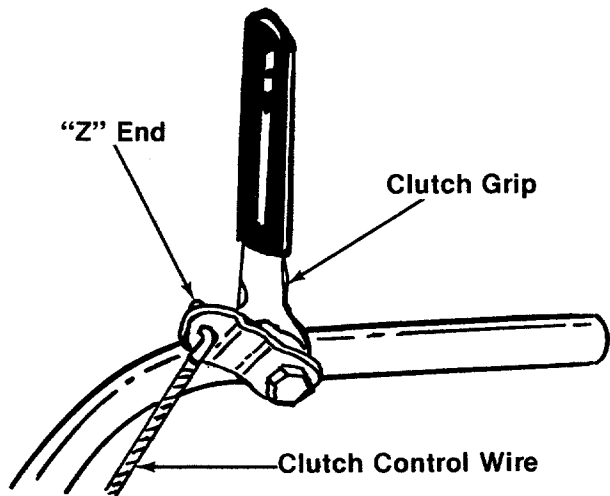

FIGURE 16.

18. Hook the "Z" end of clutch cable wire into clutch grip. See figure 16.
19. Hold the clutch grip so that the grip is down against the handle. Adjust the clutch control cable so that the slack is taken out of the control wire. Tighten the two hex nuts at the cable support bracket. Control wire should now be straight.

NOTE

Do not overtighten control wire. Too much tension may cause it to break.

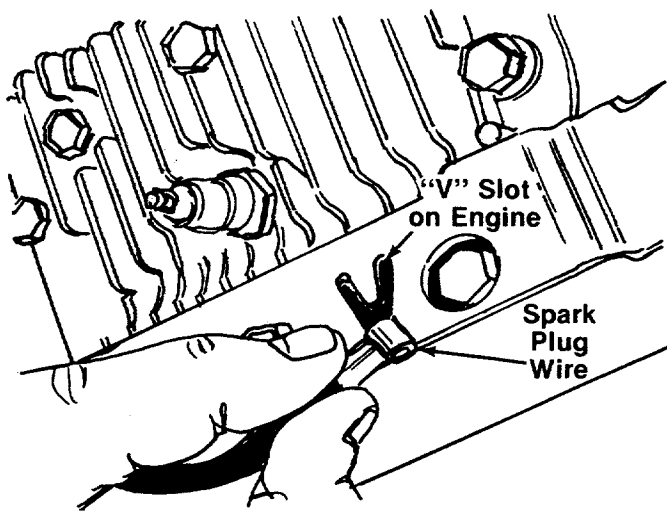

FIGURE 17.

20. To check the adjustment, disconnect the spark plug wire from spark plug to prevent accidental starting. Secure end of spark plug wire in the "V" slot on the engine. See figure 17. With the clutch grip released (neutral position), pull starter cord several times. **The tines should not turn.** If they do, adjust the hex nuts at the cable support bracket. Check again for correct adjustment.

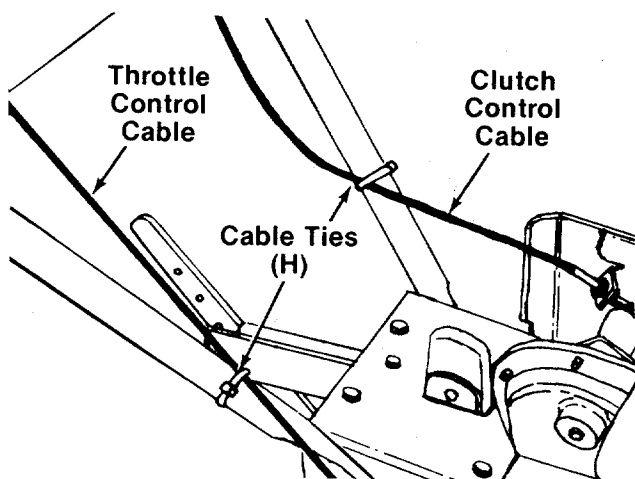

FIGURE 18.

21. Secure the throttle control cable and clutch control cable to the handle and brace with cable ties (H) provided. Cut off excess ends. See figure 18.
22. Assemble the grips to the ends of the upper handles. They will slip on more easily if they are first soaked in warm, soapy water.

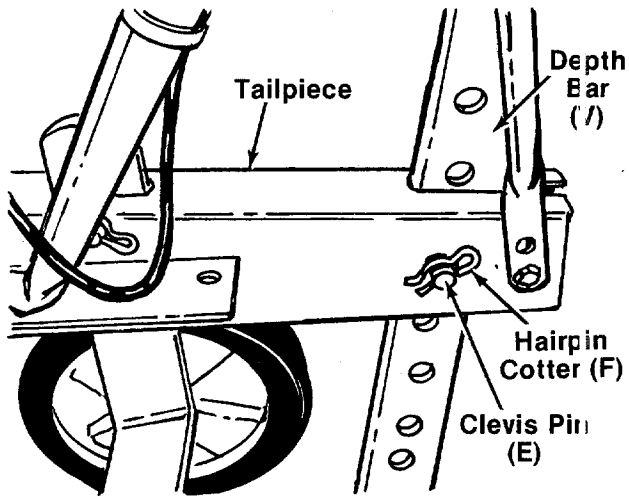

FIGURE 19.

23. Place the depth bar (V) in position on the tailpiece. Secure with clevis pin (E) and hairpin cotter (F). See figure 19.

OPERATION

BEFORE STARTING ENGINE

1. Before starting, fill crankcase with 1¼ pints of oil full to point of overflowing. Be sure that the engine is level. See figure 20.
Use SAE No. 30 MS, SC, SD or SE oil. If not available, use SAE 10W-30.
2. Fill fuel tank with clean, fresh, lead-free, low-lead or regular grade leaded gasoline.

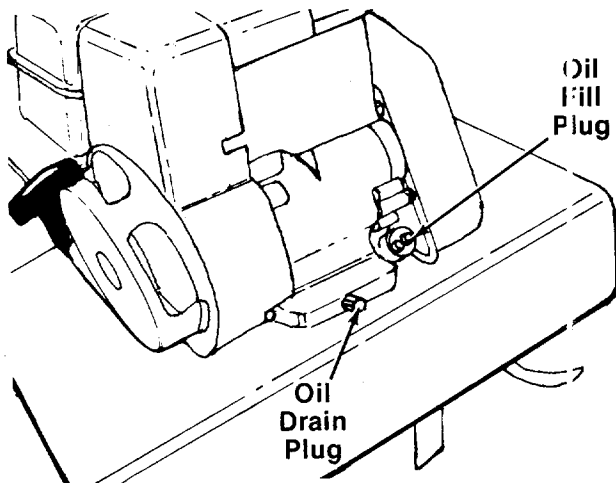

FIGURE 20.

TO START ENGINE



WARNING

BE SURE NO ONE IS STANDING IN FRONT OF THE TILLER WHILE THE ENGINE IS RUNNING OR BEING STARTED.

1. Move the throttle control lever forward to "FAST" position. See figure 21.

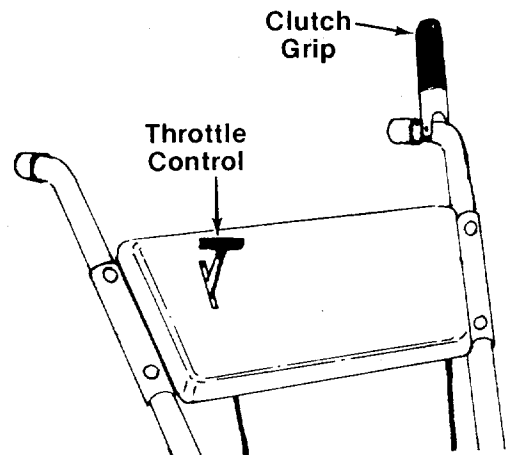

FIGURE 21.

2. Move choke lever to "CHOKE" position. See figure 22. After the engine starts, gradually push the choke lever off.

NOTE

A warm engine may not require choking.

3. Stand at side of the tiller, grasp the starter handle and pull out rapidly. Return it slowly to the engine. Repeat if necessary.

TO STOP ENGINE

Move control lever to "STOP" position. See figure 21.

TO ENGAGE TINES

To engage the tines, squeeze the clutch grip. To stop the tines, release the clutch grip. See figure 21.

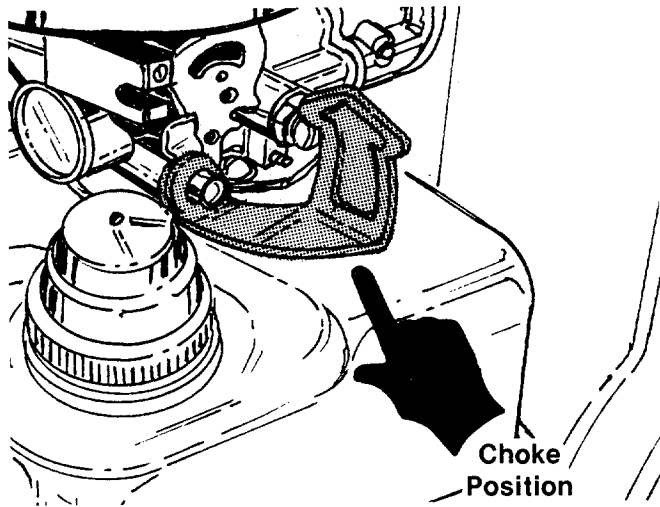

FIGURE 22.

HOW TO USE YOUR TILLER

The tiller is a precision built machine designed for seed bed preparation, cultivating, furrowing and mulching. It is engineered to minimize the hardest work in the vegetable or flower garden, to till the soil for planting and cultivating, and for performing many other useful labor saving tasks in the garden. With the proper amount of care and maintenance, this machine will provide the owner with many years of excellent service.

WHEEL POSITION

The tiller is shipped with the wheels adjusted such that the unit sits level. During digging as the tines enter the ground and the front of the tiller lowers, the wheels must be raised to level the unit. This is essential for proper engine operation. This adjustment is made by removing the clevis pin and hairpin cotter from wheel yoke, raising the wheels to the desired height, and replacing the clevis pin and hairpin cotter. See figure 23.

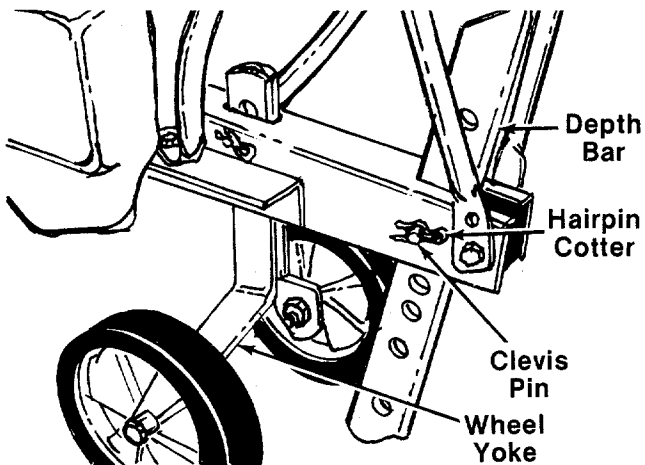

FIGURE 23.

CONTROLLING SPEED AND TILLING DEPTH:

1. **Wheel Yoke Adjustment:** Place wheel yoke so that the wheels are forward (nearest point between wheels and tines) for shallow tilling, cultivating and transport. This will also increase the forward speed. See figure 24. Turn yoke around (farthest point between wheels and tines) for deep tilling. Forward speed will decrease. See figure 24.

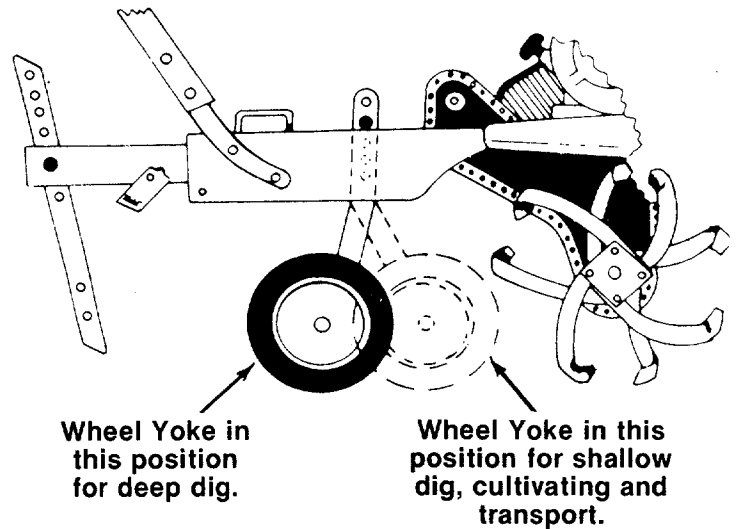

FIGURE 24.

2. **Depth Bar Adjustment:** The depth bar acts as a brake for the tiller and controls the depth and speed at which the machine will operate. See figure 25. Remove the clevis pin and hairpin cotter to raise or lower depth bar.

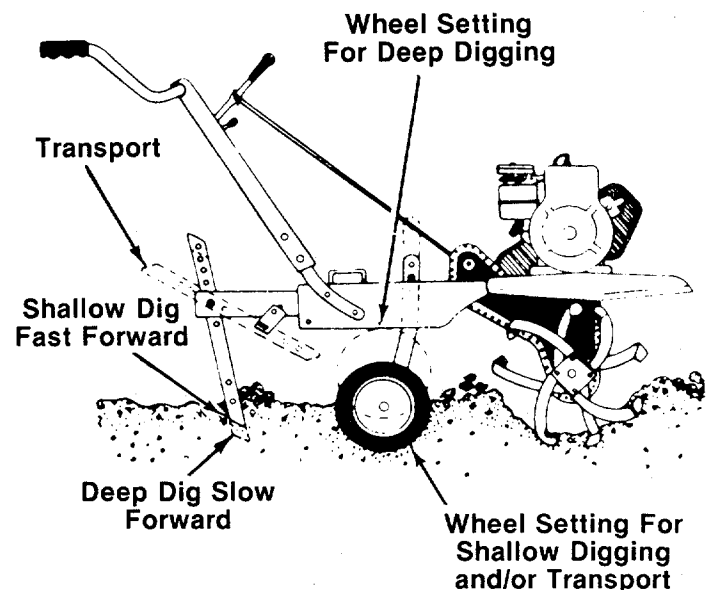

FIGURE 25.

By increasing the depth of the depth bar, the forward speed of the machine is reduced, and the working depth is increased. When the depth bar is raised, the working depth of the machine is reduced and the forward speed is increased. The working depth of the machine may be predetermined by setting the depth bar and wheels so that the wheels are about four inches from the ground when the tines and depth bar are resting on the ground. This setting will permit a working depth of about four inches. When presetting the working depth, the handles should be a little above waist height because the complete tiller will be lower when the tines and depth bar penetrate the ground. The best method will be determined by the soil condition. In some soils, the desired depth is obtained the first time over the garden. In other soils, the desired depth is obtained by going over the garden two or three times. In the latter case, the depth bar should be lowered before each succeeding pass over the garden, and passes should be made across the length and width of the garden alternately. Rocks which are turned up should be removed from the garden area.

3. Handle Pressure: Further control of tilling depth and travel speed can be obtained by variation of pressure on the handles. A downward pressure on the handles will reduce the working depth and increase the forward speed. An upward pressure on the handles will increase the working depth and reduce the forward speed. The type of soil and working conditions will determine the actual setting of the depth bar and the handle pressure required.

4. Throttle Control: The throttle control lever is located on the right side of handle panel.



NOTE

Right hand side is determined from the operator's position standing behind the tiller.

The throttle control lever adjusts the engine speed. It also gives finger tip control of the carburetor and magneto stop switch. With the throttle control knob pushed completely forward, the carburetor is in START position. Pulling the throttle control back slightly adjusts the engine speed to FAST. Pulling the throttle back further reduces the engine speed to SLOW. When the throttle is pulled completely back, the magneto stop switch grounds out the spark and stops the engine. Use maximum engine speed for deep tilling.

Move the throttle control to slow when transporting the tiller. When the tiller is being moved to or from the garden, the depth bar should be pivoted forward until it engages the depth bar spring pin. The machine may be moved under its own power, without damaging grass areas as long as it is allowed to move freely. If the operator holds back, it will start to dig.

CULTIVATING

For cultivating, a two to three inch depth is desirable. Setting the wheels and depth bar so that the wheels are about two inches above the ground while the tiller is resting on the tines and depth bar will allow the machine to work at cultivating depth. The throttle should be set to control forward movement to a slow walking speed. With standard tines, the maximum working width of the tiller is 26 inches. This width may be reduced to 24 inches by moving the clevis pins and hairpin cotter to the inner holes on the tine shaft. For cultivation, remove the outer tines to obtain a tilling width of 13 inches.

When laying out plant rows, be sure to allow enough width to permit cultivation between the rows. In growing corn or similar crops, check-row planting will permit cross cultivation and practically eliminate hand hoeing.

The tiller has many uses other than tilling and cultivating a garden. One of these is the preparation of lawn area for seeding. The tiller will prepare a deep seed bed which will be free of hard untilled spots, allowing a better stand of grass to grow. The tiller is very useful for loosening hard soil for excavation with a shovel. No tedious hand pickwork will be necessary. Your tiller may be used for mixing compost in the pile, or for mixing it with the soil in your garden. This should be done after the soil has been broken to the full working depth. The compost should be worked in to a depth of six to eight inches. This may be done by working the length of the garden, and then by mixing separate passes across its width. The addition of decayed organic matter will substantially increase the fertility of your garden. For proper decaying action, fertilizer should be applied and worked in with the mulch materials. Breaking up leaves and straw and mixing it with several inches of soil causes the soil to hold moisture longer and allows proper aeration of the plant root system. It also retards the growth of weeds.

The U.S. Department of Agriculture and various state and local agencies offer published booklets and expert advice on all phases of gardening. They should be consulted regarding soil information, planting dates, and the most satisfactory varieties of crop for your particular area.

ADJUSTMENTS



Disconnect the spark plug wire and ground against the engine before performing any adjustments, repairs or maintenance.

WHEEL ADJUSTMENT

To adjust the wheel yoke and wheel position, refer to "How To Use Your Tiller" on pages 11 and 12.

DEPTH BAR ADJUSTMENT

To adjust the depth bar, refer to "How To Use Your Tiller" on pages 11 and 12.

TINE CLUTCH CONTROL ADJUSTMENT

To adjust the tine clutch control, refer to step numbers 19 and 20 under assembly instructions.

CARBURETOR ADJUSTMENT



If any adjustments are made to the engine while the engine is running (e.g. carburetor), disengage all clutches and tines. Keep clear of all moving parts and be careful of heated surfaces and muffler.

Never make unnecessary adjustments. The factory recommended settings are correct for most applications.

If adjustments are needed, refer to the engine manual packed with the tiller.

LUBRICATION

CHAIN CASE

The chain case is pre-lubricated and sealed at the factory. It requires no checking unless the chain case is disassembled. To fill with grease, lay the left half of the chain case on its side, add 12 ounces of Plastilube #0 grease and assemble the right half to it. This grease can be obtained at your nearest authorized dealer. Order Part Number 737-0133.

MAINTENANCE

ENGINE OIL

Change the oil in the crankcase after the first two hours of operation of your new engine and after each 25 hours of use thereafter to insure proper lubrication of internal parts. (Take care to remove dirt around filler plug.) Be sure oil level is maintained full to point of overflowing. See figure 20.

To change oil, remove drain plug and tip the tiller forward while engine is warm. See figure 20. Replace drain plug. Remove oil filler cap and refill with new oil of proper grade. Replace filler cap.

AIR CLEANER

The air cleaner prevents damaging dirt, dust, etc., from entering the carburetor and being forced into the engine and is important to engine life and performance.

To service air cleaner, refer to the engine manual packed with the tiller.

Never run your engine without air cleaner completely assembled.

CLEAN ENGINE

Wipe off all spilled fuel and oil. Keep the engine clean of foreign matter and be sure the cooling fins on the cylinder are kept clean to permit proper air circulation. This is an air-cooled engine and free flow of air is essential to proper engine performance and life.

SPARK PLUG

The spark plug should be cleaned and the gap reset at least once a season or when oil is changed. Spark plug replacement is recommended at the start of each mowing season; check engine manual for correct plug type and gap specification.

BELT REPLACEMENT

If belt replacement is required, order belt or belts by part number from your nearest authorized dealer.

1. Remove the belt cover by removing three self-tapping screws. A 3/8" wrench is required. See figure 26.

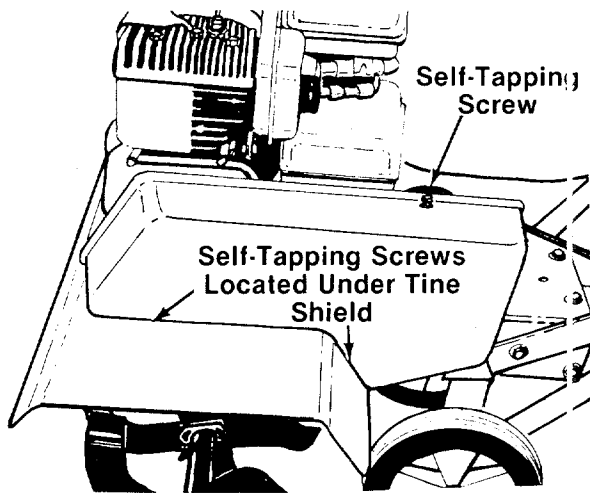

FIGURE 26.

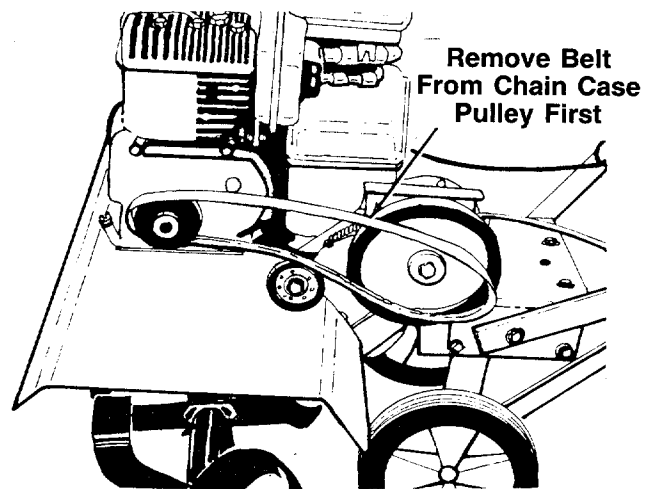

FIGURE 28.

2. After removing three screws, lift off belt cover. See figures 26 and 27.
3. Slip the belt off the chain case pulley first, then off idler pulley. Remove belt from engine pulley. See figure 28.
4. To reassemble the new belt, first place belt over engine pulley. Be sure belt is inside two pins at engine pulley. See figure 27.
5. Belt must be over top of idler pulley. See figure 27. Slip end of belt over the chain case pulley.
6. Reassemble the belt cover. See figure 26.

OFF-SEASON STORAGE

If the tiller is not to be used for a while, the following procedure should be followed. The tines, depth bar, gear case and wheels should be cleaned of all dirt. It is very important that the unit be stored in a level position to prevent engine oil from draining into the cylinder head cavity.

Engines on tillers to be stored between seasons should be completely drained of fuel to prevent gum deposits forming on essential carburetor parts and fuel tank. Refer to the engine manual for correct engine storage instructions.

Just as your automobile needs professional mechanical maintenance from time to time, so does your air-cooled engine. Cleaning and adjusting of the carburetor and periodic replacement of the spark plug and ignition points is made necessary by NORMAL use.

Professional Air-Cooled Engine Service is as close as your telephone book.

A yearly checkup or tune-up by an authorized engine dealer is a good idea to avoid breakdowns or delay... do it at the end of the season, then you're ready for the next.



When storing any type of power equipment in an unventilated or metal storage shed, care should be taken to rustproof the equipment. Using a light oil or silicone, coat the equipment, especially any chains, springs, bearings and cables.

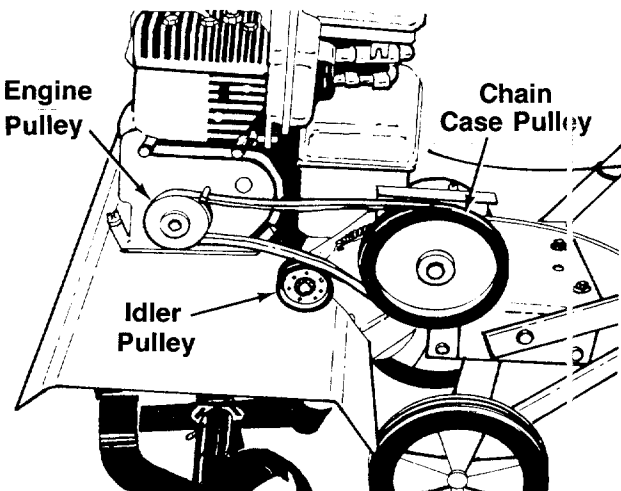

FIGURE 27.

TROUBLE SHOOTING CHART

SYMPTOM	POSSIBLE CAUSE(S)	SOLUTION
Engine fails to start	<ol style="list-style-type: none"> 1. Check fuel tank for gas. 2. Spark plug lead wire disconnected. 3. Faulty spark plug. 	<ol style="list-style-type: none"> 1. Fill tank if empty. 2. Connect lead wire. 3. Spark should jump gap between control electrode and side electrode. If spark does not jump, replace the spark plug.
Hard starting or loss of power	<ol style="list-style-type: none"> 1. Spark plug wire loose. 2. Dirty air cleaner. 	<ol style="list-style-type: none"> 1. Connect and tighten spark plug wire. 2. Clean air cleaner as described in engine manual.
Engine overheats	<ol style="list-style-type: none"> 1. Carburetor not adjusted properly. 2. Air flow restricted. 3. Engine oil level low. 	<ol style="list-style-type: none"> 1. Adjust carburetor. See engine manual. 2. Remove blower housing and clean as described in the engine manual. 3. Fill crankcase with the proper oil.
Tine control does not engage.	Belt worn and/or stretched.	Make control cable adjustment (see Assembly Instructions) or replace belt.

NOTE: For repairs beyond the minor adjustments listed above, please contact your local authorized service dealer.

Model 310

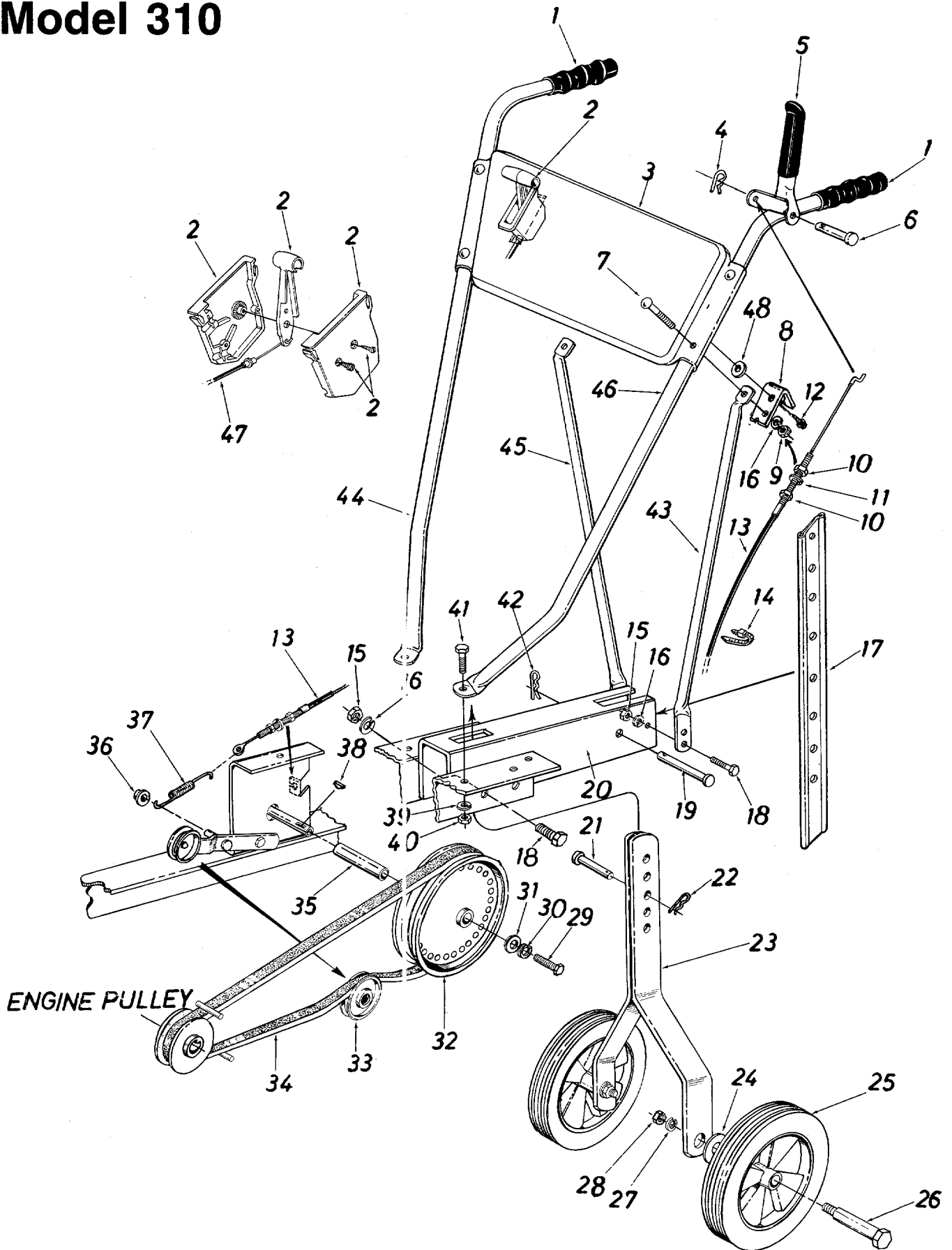

Model 310

PARTS LIST FOR MODEL 310 TILLER

REF. NO.	PART NO.	COLOR CODE	DESCRIPTION	NEW PART	REF. NO.	PART NO.	COLOR CODE	DESCRIPTION	NEW PART
1	720-0204		Grip		26	738-0318		Shoulder Bolt	
2	831-0692		Throttle Control Box		27	736-0921		L-Wash. 1/2" I.D.*	
3	784-0036		Handle Panel		28	712-0200		Hex Nut 1/2-20 Thd.*	
4	714-0104		Int. Cotter Pin		29	710-0412		Hex Bolt 1/4-28 x .75" Lg.	
5	784-0008		Clutch Grip Ass'y.		30	736-0329		L-Wash. 1/4" I.D.*	
6	711-0415		Clevis Pin		31	736-0176		FI-Wash. .25" I.D. x .930" O.D.	
7	710-0458		Carriage Bolt 5/16-18 x 1.75" Lg.*		32	756-0389		Pulley 6.00" O.D.	
8	15093		Cable Support Brkt.		33	756-0137		Idler Pulley	
9	712-0267		Hex Nut 5/16-18 Thd.*		34	754-0190		"V"-Belt 1/2" Pitch x 39" Lg.	
10	712-0256		Hex Jam Nut 5/16-24 Thd.		35	750-0472		Spacer	
11	736-0119		L-Wash. 5/16" I.D.*		36	726-0106		Cap Speed Nut	
12	710-0599		Hex Wash. Hd. Self-Tap Scr. 1/4-20 x .50" Lg.		37	732-0387		Extension Spring	
13	746-0508		Clutch Control Cable		38	714-0388		Hi-Pro Key	
14	725-0157		Cable Tie		39	736-0119		L-Wash. 5/16" I.D.*	
15	712-0267		Hex Nut 5/16-18 Thd.*		40	712-0267		Hex Nut 5/16-18 Thd.*	
16	736-0119		L-Wash. 5/16" I.D.*		41	710-0118		Hex Bolt 5/16-18 x .75" Lg.*	
17	04668		Depth Bar		42	714-0149		Hairpin Cotter	
18	710-0118		Hex Bolt 5/16-18 x .75" Lg.*		43	749-0633		Handle Support Bracket—L.H.	
19	711-0761		Clevis Pin 1/2" Dia. x 2.50" Lg.		44	749-0626		Handle Bar—R.H.	
20	784-0005		Tailpiece Ass'y.		45	749-0632		Handle Support Bracket—R.H.	
21	711-0755		Clevis Pin 3/8" Dia. x 2.50" Lg.		46	749-0627		Handle Bar—L.H.	
22	714-0149		Hairpin Cotter		47	746-0503		Throttle Control Cable—35"	
23	06813		Wheel Bracket Ass'y.		48	736-0142		FI-Wash. .281" I.D. x .50" O.D.	
24	736-0253		Belleville Wash. 1/2" I.D.		49	710-0779		Self-Tap Scr. #10 x 1/2" Lg.	
25	734-0968		Wheel Ass'y. 9 x 1.75						

*For faster service obtain standard nuts, bolts, and washers locally. If these items cannot be obtained locally, order by part number and size as shown on parts list.

(463—Top Flite Red) When ordering parts if color or finish is important, use the appropriate color code shown at left. (e.g. Top Flite Red Finish—04947 (463).)

NOTE: The engine is not under warranty by the tiller manufacturer... If repairs or service is needed on the engine, please contact your nearest authorized engine service outlet. Check the "Yellow Pages" of your telephone book under "Engines—Gasoline."



NOTE

This instruction manual covers various models and all specifications shown do not necessarily apply to your model. Specifications subject to change without notice or obligation.

Model 310

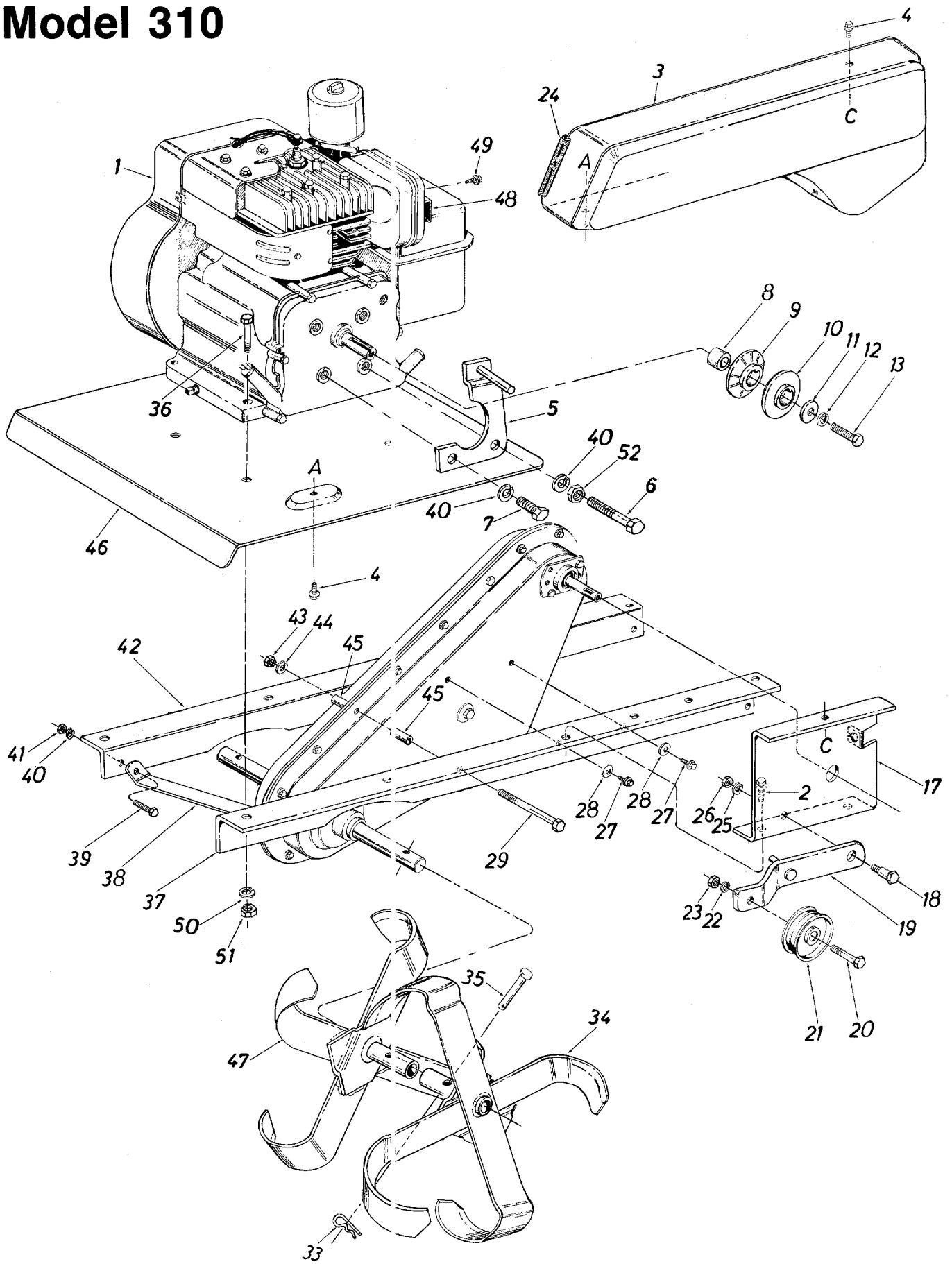

Model 310

PARTS LIST FOR TILLER MODEL 310

REF. NO.	PART NO.	COLOR CODE	DESCRIPTION	NEW PART	REF. NO.	PART NO.	COLOR CODE	DESCRIPTION	NEW PART
1	—		Engine		26	712-0342		Hex Jam Nut 3/8-16 Thd.	
2	710-0600		Hex Wash. Hd. Self-Tap Scr. 5/16-24 x .50" Lg.		27	710-0599		Hex Wash. Hd. Self-Tap Scr. 1/4-20 x .50" Lg.	
3	04958	463	Belt Cover		28	736-0270		Belleville Wash. .26 I.D. x .75 O.D. x .060	
4	710-0599		Hex Wash. Hd. Self-Tap Scr. 1/4-20 x .50" Lg.		29	710-0176		Hex Scr. 5/16-18 x 2.75" Lg.*	
5	784-0114		Belt Keeper Brkt. Ass'y.	N	33	714-0149		Hairpin Cotter	
6	710-0593		Hex Bolt 5/16-24 x 2.25" Lg. (Gr. 5)		34	—		See Tine Chart Below	
7	710-0237		Hex Bolt 5/16-24 x .62" Lg. (Gr. 5)		35	1545-029		Clevis Pin	
7	710-0121		Hex Scr. 1/2-20 Thd. (Special)		36	710-0442		Bolt 5/16-18 x 1.5" Lg.*	
8	750-0345		Spacer		37	04949	463	Frame Rail—L.H.	
9	748-0282		Pulley Half		38	04933		Front Brace Brkt.	
10	748-0282		Pulley Half		39	710-0118		Hex Scr. 5/16-18 x .75" Lg.*	
11	736-0258		FI-Wash. 3/8" I.D. x 1.25" O.D. x .100		40	736-0119		L-Wash. 5/16" I.D.*	
12	736-0169		L-Wash. 3/8" I.D.*		41	712-0158		Hex Cent. L-Nut 5/16-18 Thd.	
13	710-0152		Hex Scr. 3/8-24 x 1.00" Lg.		42	04948	463	Frame Rail—R.H.	
17	04934	463	Idler Mounting Brkt.		43	712-0158		Hex Cent. L-Nut 5/16-18 Thd.	
18	738-0322		Shld. Bolt		44	736-0119		L-Wash. 5/16" I.D.*	
19	784-0027		Idler Bracket Ass'y.		45	750-0470		Spacer	
20	710-0344		Hex Scr. 3/8-16 x 1.50" Lg.		46	784-0001		Tine Shield	
21	756-0137		Idler Pulley		47	—		See Tine Chart Below	
22	736-0169		L-Wash. 3/8" I.D.*		48	751-0233		Deflector	
23	712-0342		Hex Jam Nut 3/8-16 Thd.		49	710-0783		Hex Self-Tap Scr. #8-32 x .38" Lg.	
24	731-0511		Trim Strip—3"		50	736-0119		L-Wash. 5/16" I.D.*	
25	736-0169		L-Wash. 3/8" I.D.*		51	712-0267		Hex Nut 5/16-18 Thd.*	
					52	712-0123		Hex Nut 5/16-24 Thd.*	

*For faster service obtain standard nuts, bolts, and washers locally. If these items cannot be obtained locally, order by part number and size as shown on parts list.

(463—Top Flite Red) When ordering parts if color or finish is important, use the appropriate color code shown at left. (e.g. Top Flite Red Finish—04943 (463).)

TINE CHART

Part No.	Description
784-0092	Inner Tine Ass'y. Comp.—R.H.
784-0094	Outer Tine Ass'y. Comp.—R.H.
784-0091	Inner Tine Ass'y. Comp.—L.H.
784-0093	Outer Tine Ass'y. Comp.—L.H.

Heavy Duty Garden Tiller Attachments Available for All-Season Use

31-0106	Depth Gauge Wheels (Pair)	31-0123	Lawn Aerator (Use with 31-0114 Wheel Weights for added penetration)
31-0107	6-Tine Cultivator (Must be used with 31-0106 Depth Gauge Wheels)	31-0144	"V"-Bar Cultivating Kit Kit Includes: "V"-Bar Frame, 4-Point Cultivating Tines, Hiller/Furrower, Depth Gauge Wheels (Pair).
31-0110	8" Furrower Opener	31-0145	Depth Stake Cultivating Kit Kit Includes: 8" Furrower Opener, 15" Sweep Cultivator, 32" Leveling Rake, Extra Depth Stake.
31-0111	15" Sweep Cultivator		
31-0113	Pneumatic Tires, 13 x 5.00-6 (Pair)		
31-0114	Wheel Weights (Pair)		
31-0115	Tire Chains, 13 x 5.00 (2 Link) (Pair)		
31-0119	Tine Cultivating Shields w/Adapters (Pair)		

Note: Attachments are available through your local dealer or from the factory:
Agri-Fab Inc., 303 W. Raymond Street, Sullivan, Illinois 61951 (217) 728-4334

Model 310

Chain Case Assembly 784-0103

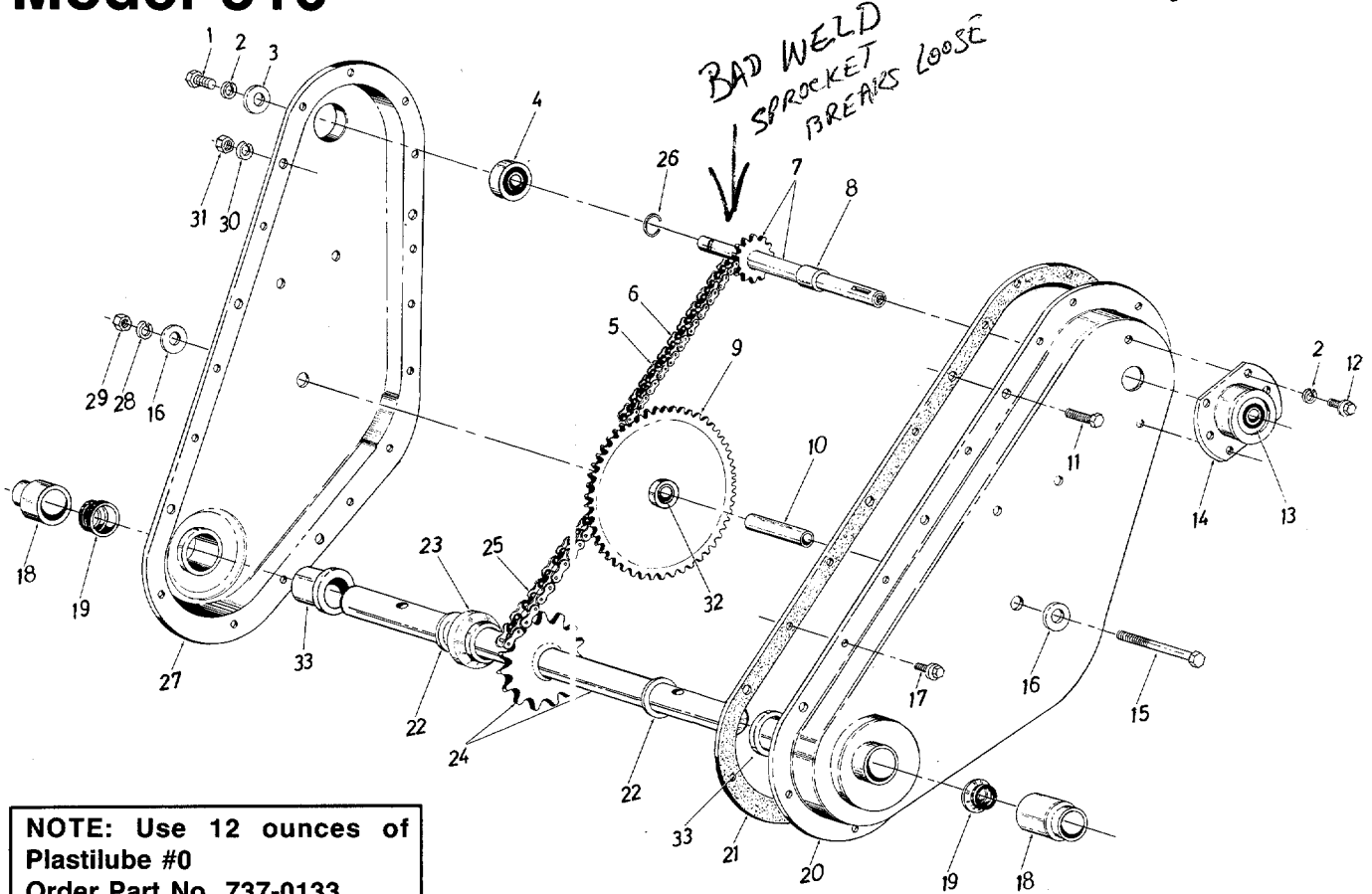

**NOTE: Use 12 ounces of Plastilube #0
Order Part No. 737-0133**

PARTS LIST FOR CHAIN CASE 784-0103

REF. NO.	PART NO.	COLOR CODE	DESCRIPTION	NEW PART	REF. NO.	PART NO.	COLOR CODE	DESCRIPTION	NEW PART
1	710-0513		Hex L-Scr. 1/4-28 x .625" Lg.		17	710-0599		Hex Wash. Hd. Self-Tap Scr. 1/4-20 x .50" Lg.	
2	736-0329		L-Wash. 1/4" I.D.*		18	731-0487		Dust Cap	
3	736-0176		Fl-Wash. .25" I.D. x .93" O.D. x .125" Thk.		19	721-0175		Seal	
4	741-0155		Bearing .62" I.D. x 1.38" O.D. x .437" Thk.		20	14985		Tiller Housing—L.H.	
5	713-0327		#35 Chain 3/8" Pitch x 52 Links—Endless		21	721-0170		Gasket	
6	713-0139		Master Link (Service Only)		22	736-0163		Thrust Wash. 1.00" I.D. x .030" Thk.	
7	04956		Input Shaft Assembly		23	750-0570		Step Spacer	
8	750-0471		Spacer		24	784-0089		Tine Shaft Assembly	
9	713-0331		Sprocket Assembly (Includes Ref. No. 32)		25	713-0328		#50 Chain 5/8" Pitch x 46 Links—Endless	
10	750-0275		Sprocket Hub Tubing 3/8" I.D. x 5/8" O.D. x 1.9" Lg.		26	716-0131		Snap Ring	
11	710-0118		Hex Scr. 5/16-18 x .625" Lg.*		27	14984		Tiller Housing—R.H.	
12	710-0599		Hex Wash. Hd. Self-Tap Scr. 1/4-20 x .50" Lg.		28	736-0169		L-Wash. 3/8" I.D.*	
13	741-0155		Bearing .625" I.D. x 1.38" O.D. x .437" Thk.		29	712-0711		Hex Nut 3/8-24 Thd.	
14	05034		Bearing Housing		30	736-0119		L-Wash. 5/16" Scr.*	
15	710-0629		Hex Scr. 3/8-24 x 2.75" Lg.		31	712-0267		Hex Nut 5/16-18 Thd.*	
16	736-0258		Fl-Wash. 3/8" I.D. x 1.25" O.D. x .100 Thk.		32	741-0304		Bearing (For Service Only—Must be Press Fit)	
					33	731-0374		Bearing	

*For faster service obtain standard nuts, bolts, and washers locally. If these items cannot be obtained locally, order by part number and size as shown on parts list.

PARTS INFORMATION

POWER EQUIPMENT PARTS AND SERVICE

Parts and service are available through the authorized service firms listed below. All orders should specify the model number of your unit, part numbers, description of parts and the quantity of each part required.

BRIGGS AND STRATTON, TECUMSEH AND PEERLESS PARTS AND SERVICE

Briggs & Stratton, Tecumseh and Peerless parts and service should be handled by your nearest authorized engine service firm. Check the yellow pages of your telephone directory under the listing **Engines—Gasoline**, Briggs & Stratton or Tecumseh Lauson.

NOTE: If any parts are found to be missing or defective upon assembly of this unit, write to advise the factory so that immediate replacement can be made.

ALABAMA	BIRMINGHAM	NORTH CAROLINA	GOLDSBORO
Auto Electric & Carburetor Co.	2625 4th Ave. S. 35233	Smith Hardware Co.	515 N. George St. 27530
ARKANSAS	NORTH LITTLE ROCK	Dixie Sales Company	GREENSBORO
Sutton's Lawn Mower Shop	5301 Roundtop Drive	Box 368, Rt. 4 72117	335 N. Green 27402
CALIFORNIA	PORTERVILLE	OHIO	CARROLL
Billious	75 North D Street 33257	Stebe's Mid-State Mower Supply	Box 366, 71 High St. 43112
COLORADO	DENVER	Bleckrie, Inc.	CLEVELAND
Spitzer Industrial Products Co.	6601 N.	National Central	7900 Lorain Ave. 44102
FLORIDA	Washington St. 30229	Burton Supply Co.	WADSWORTH
Radco Distributors	JACKSONVILLE	Box 929 44501	687 Seville Rd. 44281
Small Eng. Dist.	4909 Victor St.	OKLAHOMA	YOUNGSTOWN
GEORGIA	Box 5459 32207	Victory Motors, Inc.	1301 Logan Ave.
East Point Cycle & Key Inc.	HIALEAH	7995 W. 26th Court. 33016	Box 929 44501
ILLINOIS	EAST POINT	OREGON	MUSKOGEE
Keen Edge Co.	2834 Church St. 30344	Kenton Supply Co.	605 S. Cherokee 74401
INDIANA	LYONS	PENNSYLVANIA	PORTLAND
Parts & Sales Inc.	8615 Ogden Ave. 30534	EECO Inc.	8216 N. Denver Ave. 97217
IOWA	ELKHART	Thompson Rubber Co.	HARRISBURG
Power Lawn & Garden Equip.	2101 Industrial Pkwy. 46516	Bluemon Co.	4021 N. 6th St. 17110
LOUISIANA	DUBUQUE	Frank Roberts & Sons	WILLOW GROVE
Suhren Engine Co.	2551 J.F. Kennedy 52001	Scranton Auto Ignition Co.	850 Davisville Rd. 19090
MARYLAND	NEW ORLEANS	TENNESSEE	PITTSBURGH
Center Supply Co.	8330 Earhart Blvd. 70118	Ace Distributors	11125 Frankstown Rd. 15235
MASSACHUSETTS	TAKOMA PARK	American Sales & Service, Inc.	PUNXSUTAWNEY
Morton B. Collins Co.	6867 New Hampshire	TEXAS	R.D. 2 15767
MICHIGAN	Ave. 20912	Marr Brothers, Inc.	SCRANTON
Lorenz Service Co.	SPRINGFIELD	Woodson Sales Corp.	1133-35 Wyoming Ave. 18509
Power Equipment Dist.	300 Birnie Ave. 31107	Bullard Supply Co.	KNOXVILLE
MINNESOTA	LANSING	Engine House Inc.	2103 Magnolia 37915
Hance Distributing Inc.	2500 S. Pennsylvania 48910	UTAH	MEMPHIS
MISSOURI	MOUNT CLEMENS	Powered Products	3035-43 Bellbrook 38116
Automotive Equip. Service	340 Hubbard 48043	VIRGINIA	DALLAS
Ross-Frazer Supply Co.	HOPKINS	RBI Corp.	423 E. Jefferson 75203
Henzler, Inc.	420 Excelsior Ave. W. 55343	Woodson Sales Corp.	FORT WORTH
NEW JERSEY	KANSAS CITY	Hwy. 10 76118	6733 Baker Blvd.
Lawnmower Parts Inc.	3117 Holmes St. 34109	HOUSTON	Hwy. 10 76118
NEW MEXICO	ST. JOSEPH	2409 Commerce St. 77003	SAN ANTONIO
Spitzer Eng. & Parts Co.	8th and Monterey 34503	Engine House Inc.	8610 Botts Lane
NEW YORK	ST. LOUIS	P.O. Box 17867 78217	SALT LAKE CITY
Gamble Dist., Inc.	2015 Lemay Ferry Rd. 63125	WASHINGTON	1661 N. Beck St. 84116
	BELLMAWR	Equip. Northwest	ASHLAND
	717 Creek Rd. 08030	WISCONSIN	101 Cedar Ridge Dr. 23005
	ALBUQUERQUE	Wisconsin Magneto Inc.	SEATTLE
	1023 Third Ave. N.W. 87103		1410 14th Ave. 98122
	CARTHAGE		MILWAUKEE
	West End Ave. 13619		4727 N. Teutonia St. 53209

WARRANTY PARTS AND SERVICE POLICY

(0685)

The purpose of warranty is to protect the customer from defects in workmanship and materials, defects which are NOT detected at the time of manufacture. It does not provide for the unlimited and unrestricted replacement of parts. Use and maintenance are the responsibility of the customer. The manufacturer cannot assume responsibility for conditions over which it has no control. Simply put, if it's the manufacturer's fault, it's the manufacturer's responsibility; if it's the customer's fault, it's the customer's responsibility.

CLAIMS AGAINST THE MANUFACTURER'S WARRANTY INCLUDES:

1. Replacement of Missing Parts on new equipment.
2. Replacement of Defective Parts within the warranty period.
3. Repair of Defects within the warranty period.

All claims MUST be substantiated with the following information:

1. Model Number of unit involved.
2. Date unit was purchased or first put into service.
3. Date of failure.
4. Nature of failure.

MTD PRODUCTS INC • P.O. BOX 36900 • CLEVELAND, OHIO 44136

Free Manuals Download Website

<http://myh66.com>

<http://usermanuals.us>

<http://www.somanuals.com>

<http://www.4manuals.cc>

<http://www.manual-lib.com>

<http://www.404manual.com>

<http://www.luxmanual.com>

<http://aubethermostatmanual.com>

Golf course search by state

<http://golfingnear.com>

Email search by domain

<http://emailbydomain.com>

Auto manuals search

<http://auto.somanuals.com>

TV manuals search

<http://tv.somanuals.com>