

Your New

Model No. 219-360

10 CENTS



ROTARY TILLER

WARRANTY

For one year from date of purchase, MTD Products Inc will replace for the original purchaser, free of charge, F.O.B. factory or authorized service firm, any part or parts found to be defective in material or workmanship. All transportation charges on parts submitted for replacement under this warranty must be paid by the purchaser. This warranty does not include replacement of parts which become inoperative through misuse, excessive use, accident, neglect, improper maintenance or alterations by unauthorized persons. This warranty does not include the engine, motor, battery, battery charger or any component parts thereof. For service on these units refer to the applicable manufacturer's warranty.

The above warranty will apply only to the original owner and will be effective only if the warranty card has been properly processed. It will not apply where the unit has been used commercially.

Warranty service is available through your local authorized service dealer or distributor. **UNDER NO CIRCUMSTANCES WILL THE RETURN OF A COMPLETE UNIT BE ACCEPTED BY THE FACTORY UNLESS PRIOR WRITTEN PERMISSION HAS BEEN EXTENDED.**

SAFETY RULES

Your rotary tiller is a precision built machine designed to take the work out of gardening and other related chores. It can be used for seed bed preparation, tilling, cultivating, furrowing, composting and mulching. Like any other piece of power equipment, it requires a certain amount of care and maintenance. In return for this, it will give a maximum of service and efficiency. Read these instructions carefully before assembling or operating your tiller. Through proper care and operation, you will obtain long, efficient service and trouble free operation.

1. Your tiller is a precision piece of power equipment. Exercise extreme caution at all times.
2. Do not attempt to start engine with the clutch control in engaged or "Forward" position.
3. Stand clear of tines when starting engine. Never stand in front of, or work on tines while the engine is running.
4. **NEVER** place hands or feet in the vicinity of the tines while the engine is running.
5. Always stop engine when tiller is not in actual use.
6. Always disconnect spark plug wire during repairs or refueling operations.
7. Do not fill gas tank while engine is running. Do not spill gasoline on hot engine.

MTD PRODUCTS INC • 5389 WEST 130th ST. • P.O. BOX 2741 • CLEVELAND, OHIO 44111

- Inner Tine Assembly - R. H. - Complete 901-4296
- Inner Tine Assembly - L. H. - Complete 901-4295
- Outer Tine Assembly - R. H. - Complete 901-4298
- Outer Tine Assembly - L. H. - Complete 901-4297

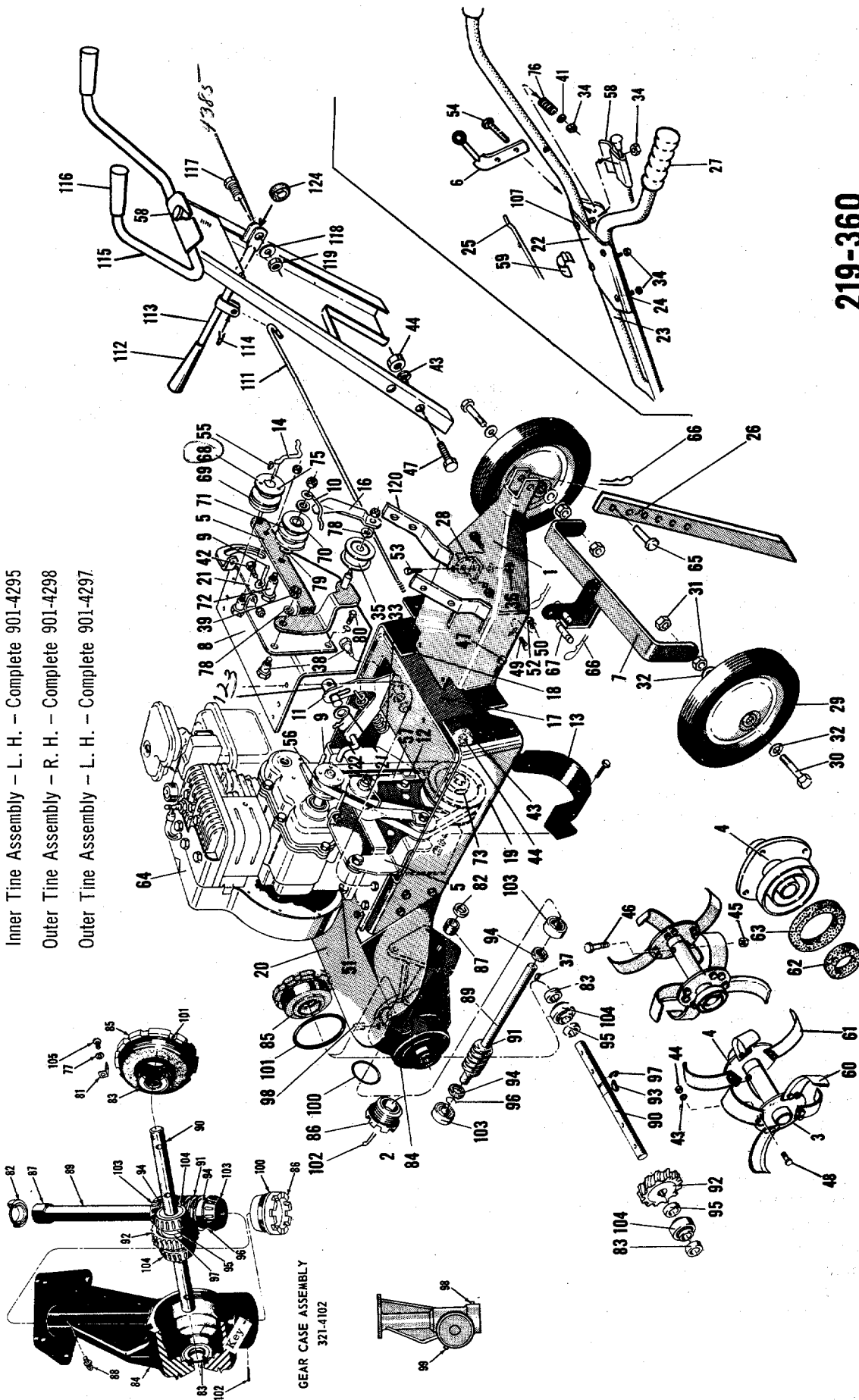

219-360

PARTS LIST FOR MODEL MTD 219 - 360

Illus. No.	Part No.	DESCRIPTION () - No. Required Per Assembly	Illus. No.	Part No.	DESCRIPTION () - No. Required Per Assembly
1	395-4330	Tailpiece Assembly	67	711-137	Support Pin
2	321-4102-1	Gear Case Assembly (Complete)	68	716-104	Pulley 756-104
3	395-4265	Outer Tine Adapter Assembly	69	717-109	Reverse Drive Wheel
4	395-4266	Inner Tine Adapter Assembly	70	748-111	Bronze Sleeve Bearing
5	310-4168	Reverse Pivot Bracket Assembly	71	756-112	Pulley - 2 Stage
6	310-4164	Control Handle Assembly	72	711-138	Shoulder Screw
7	321-4172	Wheel Hanger Assembly	73	756-108	Pulley - 2 Stage
8	395-4170	Engine Mounting Plate	74	710-765	Set Screw - Allen 5/1624 x 1/4 lg. Not Shown
9	310-4149	Belt Retainer			
10	310-4151	Belt Retainer	75	710-185	Allen Socket Head Cap Screw 10-32 x 1 lg.*
11	310-4158	Control Lever	76	732-958	Spring - Compression
12	310-4148	Belt Clip	77	736-147	Lockwasher #10 Screw*
13	321-4162	Belt Guard	78	736-300	Washer 3/8 I.D.*
14	310-4155	Control Rod	79	736-466	Washer 17/32 I.D. *
15	310-8271	Adjustment Tube	80	710-122	Hex Hd. Cap Scw. 5/16-24 x 1 lg.*
16	310-4147	Belt Clip	81	310-4101	Locking Clamp +
17	395-4399	Rear Frame	82	721-100	Oil Seal - Garlock #76 x 6113 +
18	395-4398	Side Frame - R.H.	83	721-101	Oil Seal - Garlock #78 x 7510 +
19	395-4397	Side Frame - L.H.	84	719-100	Housing - Gear Case +
20	312-4395	Dust Shield	85	719-101R	Bearing Adjustment Cap - 1"
21	310-4167	Adjustment Plate	86	719-102	Bearing Adjustment Cap - 3/4" +
22	395-4243	Handle Panel	87	748-106	Bronze Sleeve Bearing +
23	310-4246	Handle - R.H.	88	737-108	Alemite Drive Fitting #1992-B1 **
24	310-4247	Handle - L.H.	89	711-132	Worm Shaft - 3/4" +
25	711-394	Control Rod	90	711-133	Tine Shaft - 1" +
26	321-4328	Depth Bar	91	717-104	Worm +
27	305-1166	Grip	92	717-105	Worm Wheel +
28	310-4124	Handle Mounting Bracket	93	714-103	Key - Woodruff #91 **
29	501-8929	Wheel Assembly	94	711-130	Spacer - 3/4" +
30	710-275	Hex Hd. Cap Scw. 1/2-13 x 5 lg.*	95	711-131	Spacer - 1" +
31	712-384	Hex Centerlock Nut 1/2-13 thd.*	96	716-101	Snap Ring - Tru Arc #5100-75 **
32	736-108	Washer 33/64 I.D.*	97	716-102	Snap Ring - Tru Arc #5100-175 **
33	732-376	Spring-Tension	98	737-102	Pipe Plug - Special Breather Type +
34	712-107	Hex Centerlock Nut 1/4-20 thd.*	99	737-103	Pipe Plug - Square Head 3/8 thread **
35	756-370	Idler Bearing Assembly	100	735-100	"O" Ring 2-1/8 x 2-3/8 x 1/8 +
36	712-372	Hex Centerlock Nut 5/16-18 thd.*	101	735-101	"O" Ring 3-5/8 x 3-7/8 x 1/8 +
37	714-314	Key - Hi Pro #606	102	714-474	Cotter Pin 1/8 Dia. x 3/4 lg. **
38	710-373	Shoulder Bolt	103	741-107	Roller Bearing - Timken 3/4" +
39	712-430	Hex Elastic Stop Nut 3/8-16 thd.	104	741-108	Roller Bearing - Timken 1" +
40	712-123	Hex Nut 5/16-24 thd.*	105	710-125	Rd. Hd. Mach. Scw. 10-24 x 1/2 lg. **
41	736-463	Washer 9/32 I.D.*	107	710-256	Carriage Bolt 1/4-20 x 1-1/2 lg. *
42	710-258	Hex Hd. Cap Scw. 1/4-20 x 5/8 lg.*	109	710-252	Hex Hd. Cap Scw. 1/4-20 x 3/4 lg. *
43	736-169	Lockwasher 3/8 Screw*	110	712-324	Hex Stop Nut 1/4-20 thread *
44	712-798	Hex Nut 3/8-16 thd.*	111	711-402	Control Rod
45	712-116	Hex Elastic Stop Nut 3/8-24 thd. *	112	720-143	Knob
46	710-113	Hex Hd. Cap Scw. 3/8-24 x 1-5/8 lg Heat Treated *	113	310-4392	Handle Rod Assembly
47	710-253	Hex Hd. Cap Scw. 3/8-16 x 1 lg. *	114	714-115	Cotter Pin 1/8 x 1 lg. *
48	710-183	Hex Hd. Cap Scw. 3/8-16 x 1-1/8 lg.*	115	395-4381	Handle Assembly
49	710-451	Carriage Bolt 5/16-18 x 3/4 lg.*	116	305-1166	Grip
50	736-119	Lockwasher 5/16 Screw *	117	710-106	Hex Head Cap Screw 1/4-20 x 1 1/4 lg. *
51	710-442	Hex Hd. Cap Scw. 5/16-18 x 1-1/2 lg.*	118	736-195	Flat Washer
52	712-267	Hex Nut 5/16-18 thd.*	119	712-324	Hex Elastic Stop Nut 1/4-20 thd.
53	710-118	Hex Hd. Cap Scw. 5/16-18 x 3/4 lg.*	120	395-4386	Brackets - Panel
54	710-136	Hex Hd. Cap Scw. 1/4-20 x 1-3/4 lg.*	121	736-204	Flat Washer *
55	714-105	Key - Square 3/16 x 3/16 x 1 lg. *	122	714-507	Cotter Pin 3/32 x 3/4 lg. *
56	754-121	"V" Belt 1/2 x 31.8 - Gates *	123	711-392	Ferrule
57	754-103	"V" Belt 1/2 x 27 - Gates *	124	736-155	Rubber Washer
58	746-122	Control - Throttle (complete)		901-4295	Inner Tine Assembly - L.H. - Complete
59	746-111	Cable Clip		901-4296	Inner Tine Assembly - R.H. - Complete
60	742-113	Tine - L.H.		901-4297	Outer Tine Assembly - L.H. - Complete
61	742-110	Tine - R.H.		901-4298	Outer Tine Assembly - R.H. - Complete
62	736-124	Dust Pad		727-112	Lubricant 5 oz. (Gear Case)
63	736-125	Dust Pad			
64		Engine			
65	711-231	Clevis Pin			
66	714-106	Locking Pin			

* For faster service obtain standard nuts, bolts and washers locally. If these items cannot be obtained locally, order by part number and size as shown on parts list.

† Part of Gear Case Assembly (complete) 321-4102-1.

ASSEMBLY

Your rotary tiller is shipped complete in a single carton. The tines, wheels, handles, controls and depth bar are to be assembled. This is done in the manner described below.

TINES - Mount tines on tine shaft as shown. Tines must be mounted with the cutting edges facing the front. The tiller will not operate properly unless the sharpened surface of the tines enter the soil first. Secure tines in position on the tine shaft with cap screws (46), and nuts (45). NOTE: Dust pads (62 & 63) are provided in screw pack. These must be assembled as shown.

WHEELS - Insert axle bolts (30) into wheel hubs. Secure with locknuts (31) tightened only enough to allow free movement of the wheels (29). Attach wheel and axle assemblies to tiller with support and locking pins.

HANDLE - Assemble the handle brackets (120) to the handle (115) with hex head screw (47), lockwashers, (43) and hex nuts (44). Do not tighten. Place the handle brackets (120) in the tail piece slots. Fasten the lower hole in the handle brackets to the frame with a carriage bolt 5/16-18 x 3/4 lg. (49), lockwasher (52) and hex nut (50). Tighten all screws and nuts.

CLUTCH CONTROL LEVER ASSEMBLY

LOCKOUT LEVER - Place the hex head screw 1/4-20x1 1/4 (117) through the hole in the tab below the slot in the handle panel from the right hand side. Assemble in this order: Rubber washer, lock out rod (rod bracket to the front), steel washer and lock nut. Tighten until rubber washer compresses slightly.

CLUTCH CONTROL ASSEMBLY. Screw the ferrule (123) on the threaded end of the lock out rod (111) until about 1/2" of the threads show. Insert the ferrule through the control lever (11), fasten with flat washer (121) and cotter hairpin (122). Put the lockout handle in the neutral position. Insert the lockout rod in the bracket on the lockout lever and secure with a cotter hairpin through the center of the bracket. Adjust the ferrule so both belts are slack when the lockout lever is in the neutral position.

THROTTLE - To assemble the throttle push the black plastic knob in all the way then pull it out until the detent ball clicks into the second notch. The knob will be pulled out approximately 1-3/8" when in the second notch. In this position the spring lockwasher and hex nut will slide past the detent ball. Place the conduit through the slot in the handle panel (see fig 2) and push the unit (see fig 3) in until it seats as shown (see fig 1). Secure with the spring lockwasher and hex nut.

OPTIONAL HANDLE (SMALL HANDLE PANEL)

HANDLES - Insert handles (23 & 24) into slots in tail-piece assembly (1). NOTE: The handles are left (24) and right (23) and must be positioned accordingly. Secure handles in position with cap screws (47) through the upper mounting holes and the tailpiece bracket (28). Fasten with lockwashers (43) and nuts (44). Do not tighten.

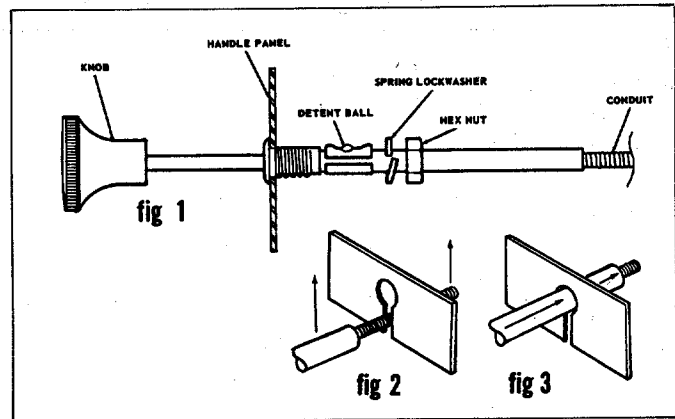

HANDLE PANEL & CLUTCH CONTROL - Assemble handle panel (22) to handles as shown. Secure top portion with carriage bolts (107) and locknuts (34). Assemble control handle assembly (6) to panel with cap screw (54), spring (76), washer (41) and locknut (34) as shown. Attach adjustment tube (15) to control rod (25). Insert formed end of control rod into control pivot lever (11) from left side. Fasten upper end to control handle assembly with cap screw (109) and locknut (110). Move throttle control knob out enough to allow face washer to be loosened. Position control (58) into slot in end of large panel. Tighten face washer. Fasten control cable to handle with cable clip (59).

DEPTH BAR - Attach depth bar (26) in desired position with clevis pin (65) and locking pin (66).

GRIPS - Assemble grips (27) to handle bars.

OPERATION

1. Check tiller tines for proper installation. With throttle control lever set on "Stop" position and the clutch control handle set in "Forward" position, slowly crank engine to determine direction of tine rotation. Be sure all tines are mounted so the sharpened edges enter the soil first.
2. Check all nuts and bolts for proper tightness. This is especially important during the initial operation period. Make this same check periodically thereafter.
3. Check throttle control for proper setting. If choke control on engine is not fully extended when the throttle control lever is on "Choke" position, reset as shown in ADJUSTMENT instructions.
4. Check gear case for proper lubricant level. With tiller on a level surface, lubricant level should be up to the front pipe plug opening. This can be checked by removing front pipe plug. Maintain correct lubricant level with Mobilube SAE 140 Gear Oil or equivalent. The gear case holds five (5) ounces of lubricant.

TILLER DRIVE MECHANISM

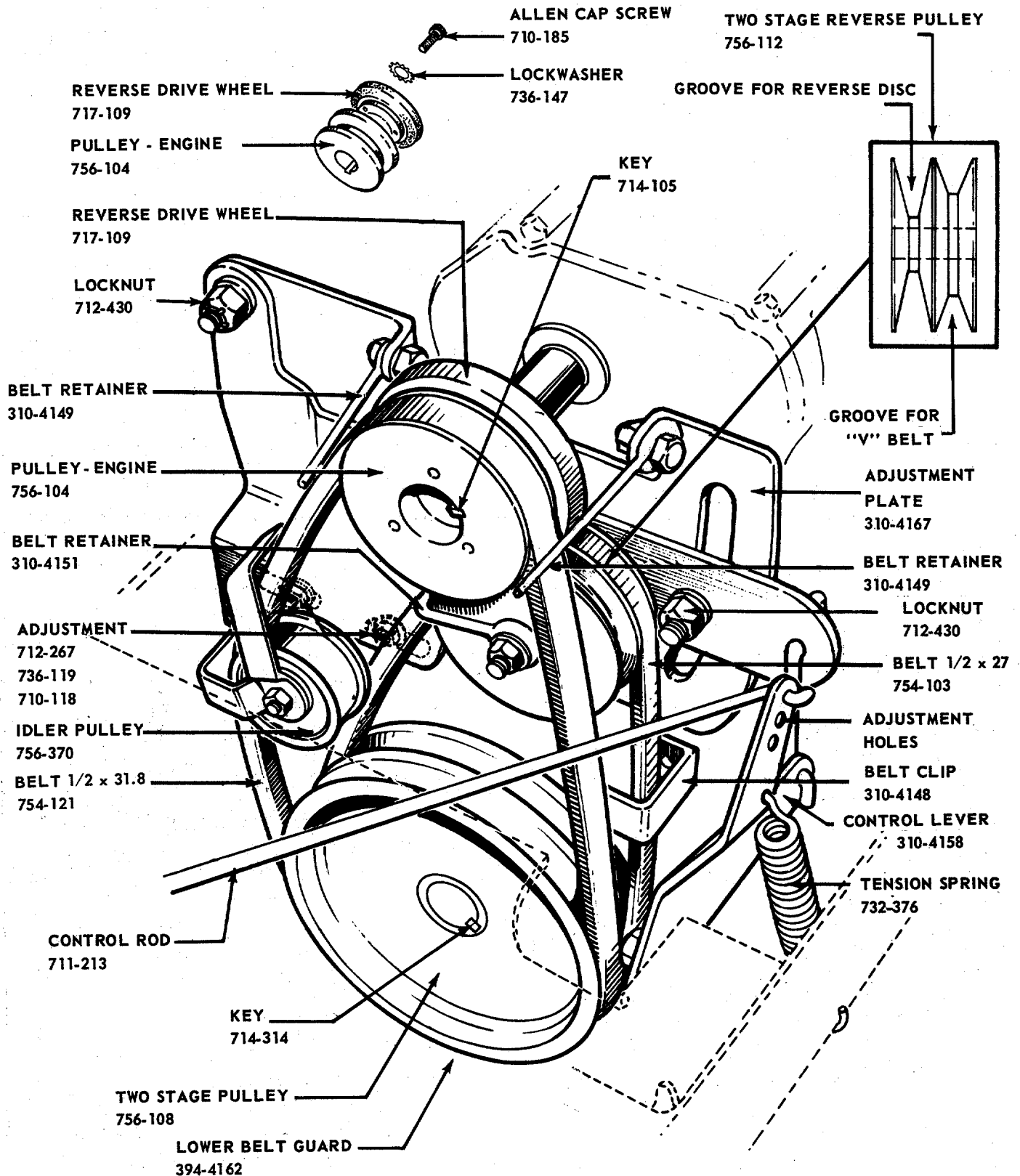

FORM NO. 770-1884G

SERVICE NOTES

DRIVE BELT SLIPS

1. Lubricate contact surface between pivot bracket assembly and adjustment plate.
2. Check pivot bracket assembly locknuts for excessive tightness.
3. Check control rod for improper assembly. If adjustment tube is attached to lower end instead of upper end, it may bind on control lever and prevent full use of tension spring.
4. If spring tension is still insufficient, adjust to another mounting hole on control lever.
5. Some measure of belt adjustment may be made by loosening the mounting bolts on the adjustment plate and moving as needed. This adjustment is usually used for reverse drive wheel adjustments.
6. Large pulley and belt may be rubbing on lower belt guard,
7. Idler pulley must operate freely.
8. Belt guard or clips must not touch the belt when it is tightened.

REVERSE DRIVE WHEEL ADJUSTMENT

1. Reverse drive wheel should line up with its matching pulley. If it does not, loosen pulley to which reversing drive wheel is attached and align as needed. When reassembling, tighten set screw securely.
2. Matching pulley for reversing drive wheel can be mounted one way only. The reversing drive wheel must operate in the deeper groove.
3. If belt retainer touches engine pulley after adjustment, move to outside mounting or bend away as needed.
4. Additional reverse adjustment may be made by loosening the mounting bolts on the adjustment plate and moving as needed.
5. Reverse should operate only when control handle assembly is held in reverse position. Adjust control rod for proper operating position.

NOTE: If belts are excessively stretched, replacement will be necessary.

ADJUSTMENTS - (see fig. 4)

To Check:

Remove Air Cleaner. Move Throttle Assembly to **CHOKE** position. The carburetor choke should then be closed. Move the Throttle to **STOP**. Control lever on carburetor should then make good contact with stop switch to short out ignition.

To Adjust:

Place Throttle on equipment in **FAST** (high speed) position. Lever "C" on carburetor should be just touching choke arm at "D". To adjust, loosen casing clamp screw "A" on blower housing. Move control casing "B" forward or backward until correct position is obtained. Tighten screw "A". Recheck above operation and replace Air Cleaner.

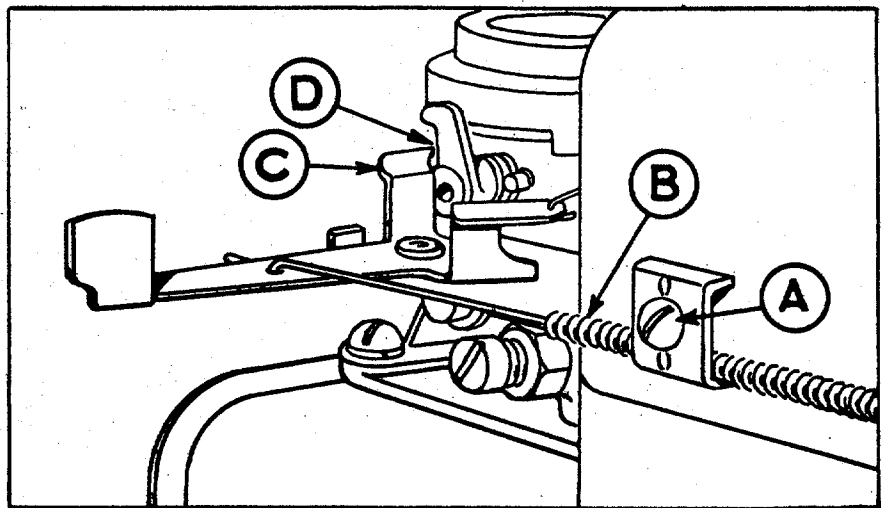

fig 4

NOTE: This instruction manual covers various models and all accessories shown do not necessarily apply to your model tiller. MTD PRODUCTS INC extends its warranty only on the tiller. If repairs or service is needed on the engine, please contact your nearest, authorized engine service outlet. Check the "Yellow Pages" of your telephone book under "Engines - Gasoline."



5. Check fuel tank. Clean, fresh, regular gasoline should be used at all times.
6. Check engine crankcase for proper oil level. The engine is shipped without oil in the crankcase. Be sure to fill crankcase before starting engine. Be sure crankcase is FULL.

NOTE: The engine is warranted separately by the engine manufacturer. For warranty service contact the engine manufacturer or their local authorized service station. All important information pertaining to care and operation is included in the engine manual.

STARTING YOUR TILLER

1. Be sure clutch control handle is in "Neutral" position.
2. Move throttle control lever to "Choke" position.
3. After cranking the engine several times, or as the engine fires, move the throttle control lever to run position.
4. Use "Choke" as needed to keep engine operating during warm-up period.
5. Adjust throttle control lever for desired operating speed.
6. To stop engine, move throttle control lever to "Stop" position. Keep throttle control lever in "Stop" position at all times when tiller is not in use.

NOTE: A brief break in period is essential to insure maximum engine life. This consists of running the engine at half speed for a period of time required to use one tank of gasoline. This is necessary on the initial run only. It is also recommended that the oil be changed after five (5) hours of operation. This allows for the removal of impurities which may have accumulated during the break in period. Subsequent oil changes should be made as stated in the engine manual. Always check oil before using your tiller. Be sure crankcase is full.

OPERATING INSTRUCTIONS

For your own convenience and safety, observe all safety suggestions shown on the front cover. Your tiller is not a toy, it is a precision piece of power equipment. Treat it as such.

It is important to recognize the fact that the forward and penetrating action of the rotary tiller is obtained from the rotating action of the tines in the soil. The depth bar acts as a brake for the tiller and controls the depth and speed at which the machine will operate. By lowering the setting of the depth bar, the forward speed of the machine is reduced and the working depth of the tines is increased. Raising the setting of the depth bar increases the forward speed and reduces the working depth. When soil conditions are severe and several passes must be made over a certain area, the depth bar setting should be lowered each time a pass is made.

Further control of tilling depth and travel speed can be obtained by variation of pressure on the handles. A downward pressure on the handles will increase the working depth and reduce the forward speed. An upward pressure on the handles will reduce the working depth and increase the forward speed. The type of soil and working conditions will determine the actual setting of of the depth bar and the handle pressure required.

1. Tine engagement and forward travel is achieved by moving the clutch control handle to "Forward" position. Tine rotation and forward motion are stopped by moving the clutch control handle to "Neutral" position. Reverse tine action and reverse travel motion can be maintained by HOLDING the clutch control handle in "Reverse" position. Releasing the handle stops reverse operation automatically.
2. The throttle control lever adjusts the engine speed. It also gives fingertip control of the carburetor choke and magneto stop switch. With the throttle control knob pushed completely forward, and carburetor is in "Choke" position. Pulling the knob out slightly releases the carburetor from "Choke" and adjusts the engine speed to "Fast." Pulling the knob further out reduces the engine speed to "Slow." When the knob is pulled completely out, the magneto stop switch grounds out the spark and stops the engine.
3. With the depth bar raised out of operation, self propelled transporting of the tiller is easily achieved. With no pressure on the handles and the throttle control set for "Slow" engine speed, move the clutch control handle to the rear position and let the tiller gently propel itself.

ADJUSTMENTS

BELTS - Belt slack is taken up by a spring loaded idler pulley. Because of this, belt adjustment is not required.

CLUTCH - No adjustment in clutch linkage is required. This is done automatically by the spring loaded idler.

"O" RING - If oil leakage at the bearing cap should occur, take up on the "o" ring of the gear case may be needed. This is accomplished by removing the locking clamp and turning the bearing adjustment cap clockwise enough to correct. Move adjustment cap back one notch and replace locking clamp.

THROTTLE - If adjustment becomes necessary, the throttle control wire assembly can be reset as follows:

1. Loosen, but do not remove, screw securing throttle control wire assembly at engine.
2. Move throttle control knob to "Choke" position.
3. Move lever, to which control wire is fastened at engine, to full choke position and retighten screw to secure throttle control wire assembly.

HANDLES - The position of the handles may be adjusted by removing and moving carriage bolts in the lower mounting holes. Adjustment should be made for the most convenient operating height.

WHEELS - Wheel positions may be varied to give adjustment of handle height. Various wheel positions also give variations of the leverage and weight distribution over the tines. Wheels should be set to suit the local soil conditions and the operator's convenience. Wheel hanger may be reversed to give variation of leverage and weight distribution.

TINES - The standard width of cut is 26". Because of the various types of work the tiller may be put to, variation in the tilling width may be necessary. This can be accomplished in a number of ways.

1. Standard tine arrangement. 26"
2. Remove outer tine assemblies (complete). 12"
3. Remove outer tines from outer tine assemblies. 20"

Tines may be interchanged with opposite sides.

4. Add tine extensions to standard arrangement. 40"
- NOTE: When adjusting tines, be sure the cutting edges enter the soil first.

MAINTENANCE AND LUBRICATION

ENGINE - Service engine in accordance with the engine manufacturer's owner's guide. NOTE: To drain oil, remove oil filler plug and tip tiller on its side. Drain oil while the engine is warm. See engine manual for filling instructions.

GEAR CASE - Proper lubricant level should be up to the front pipe plug. Check with tiller on a level surface. Add lubricant through the vented pipe plug hole. Add enough to bring level up to front plug hole. Use Mobilube SAE 140 Gear Oil or equivalent. Gear case should be maintained with five (5) ounces of lubricant. Lubricate the upper bushing in the gear case with a small amount of grease. Do not over lubricate as any excess will enter the gear case proper. Use a high pressure gun grease.

THROTTLE - Periodically lubricate throttle control lever and throttle control wire assembly with a few drops of light oil (SAE 10 or 20) for ease of operation.

REPLACING TILLER GEAR CASE OIL SEALS

1. Drain lubricant.
2. Remove tine assemblies.
3. Remove bearing adjustment cap.
4. Remove bearings, worm wheel, and tine shaft. Do not remove bearing races.
5. Remove oil seals from gear case and bearing adjustment cap.
6. Remove all burrs from holes in tine shaft.
7. Dip oil seals in lubricant and then insert one in gear case, and one in bearing adjustment cap.
8. Wipe line shaft clean of filings and lubricate before assembling with bearings and worm wheel in gear case.
9. Replace bearing adjustment cap. CAUTION: Do not damage oil seals. The open flanges face to the outside of the gear case.

10. Tighten bearing adjustment cap enough to seal "O" rings.

11. Lock bearing adjustment cap in position with locking clamp.

12. Replace tines and add lubricant.

BELTS - "V" Belts and pulley assemblies are accessible at the rear of the tiller. The belts are changed as described below.

To remove large belt -

1. Place clutch control handle in "Neutral" position.
2. Remove lower belt guard (13).
3. Loosen (Do not remove) belt clip (16) and remove belt. (56)

To remove small belt -

1. Remove large belt as described.
2. Place clutch control handle in "Forward" position.
3. Loosen belt retainer (10) and remove belt (57).

To replace small belt -

1. Position belt on pulleys. Be sure belt is in proper pulley grooves.
2. Move clutch control handle to "Neutral" position.
3. Move belt retainer (10) into position against reverse pivot bracket and tighten. Do not tighten excessively. Pulley (71) should have approximately 1/16" end play.

To replace large belt -

1. Position belt on pulley (35).
2. Position belt on pulley (68).
3. Position belt on pulley (73).
4. Replace and tighten lower guard (13).
5. Place clutch control handle in "Forward" position.
6. Tighten belt clip (16). CAUTION: Upper part of belt clip should clear belt by 1/8".

GENERAL - Check periodically all nuts and bolts, loose nuts and bolts can cause permanent damage to your unit. Keep all nuts and bolts securely tightened.

STORAGE - The following steps should be taken to prepare your tiller for storage.

1. Clean tiller thoroughly and lubricate as described in the preceding instructions.
2. Coat tilling tines with grease to prevent rusting.
3. Prepare engine for storage in accordance with engine manufacturer's owner's guide.
4. Block tiller legs to raise tires clear of floor. Be sure tiller is level.
5. Store in a dry clean area.

ATTACHMENTS

EXTENSION TINES - This attachment is available to increase your tilling width up to 40". Extension tines are easily installed and removed. Order under part number 299-165.

FURROW OPENER - This attachment is easily installed on the depth bar of your tiller. It can be used for either furrowing or hilling operations. These attachments are available through your local dealer.

For wide (2' x .43" depth bar,) order furrow opener 299-179

Free Manuals Download Website

<http://myh66.com>

<http://usermanuals.us>

<http://www.somanuals.com>

<http://www.4manuals.cc>

<http://www.manual-lib.com>

<http://www.404manual.com>

<http://www.luxmanual.com>

<http://aubethermostatmanual.com>

Golf course search by state

<http://golfingnear.com>

Email search by domain

<http://emailbydomain.com>

Auto manuals search

<http://auto.somanuals.com>

TV manuals search

<http://tv.somanuals.com>