

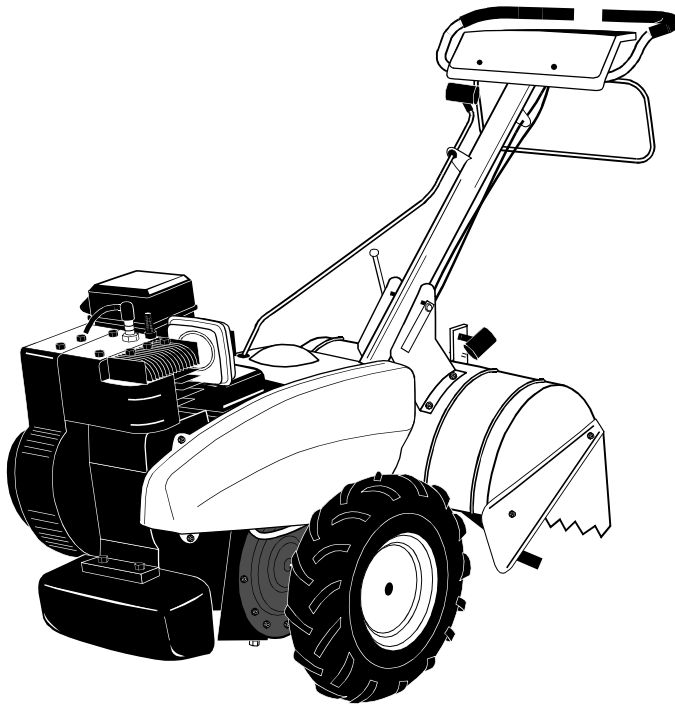

Operator's Manual



Rear Tine Tiller

Models

410 Thru 420 Series

IMPORTANT: Read safety rules and instructions carefully before operating equipment.

Warning: This unit is equipped with an internal combustion engine and should not be used on or near any unimproved forest-covered, brush-covered or grass-covered land unless the engine's exhaust system is equipped with a spark arrester meeting applicable local or state laws (if any). If a spark arrester is used, it should be maintained in effective working order by the operator. In the State of California the above is required by law (Section 4442 of the California Public Resources Code). Other states may have similar laws. Federal laws apply on federal lands. A spark arrester for the muffler is available through your nearest engine authorized service dealer or contact the service department, P.O. Box 368022 Cleveland, Ohio 44136-9722.

MTD PRODUCTS INC. P.O. BOX 368022 CLEVELAND, OHIO 44136-9722

PRINTED IN U.S.A.

FORM NO. 770-10136A
(10/99)

TABLE OF CONTENTS

Content	Page
Important Safe Operation Practices.....	3
Assembling Your Tiller.....	5
Know Your Tiller.....	8
Operating Your Tiller.....	9
Making Adjustments.....	10
Maintaining Your Tiller.....	11
Service.....	11
Off-Season Storage.....	12
Troubleshooting.....	13
Parts List.....	14

FINDING MODEL NUMBER

This Operator's Manual is an important part of your new Tiller. It will help you assemble, prepare and maintain the unit for best performance. Please read and understand what it says.



Before you start assembling your new equipment, please locate the model plate on the equipment and copy the information from it in the space provided below. The information on the model plate is very important if you need help from our Customer Support Department or an authorized dealer.

- You can locate the model number by standing in the operating position behind the unit and looking down at the center of the rear tine cover. A sample model plate is explained below. For future reference, please copy the model number and the serial number of the equipment in the space below.

_____	_____
(Model Number)	(Serial Number)



MTD PRODUCTS INC
CLEVELAND, OHIO 44136

Copy the model number here: _____

Copy the serial number here: _____

CALLING CUSTOMER SUPPORT

If you have difficulty assembling this product or have any questions regarding the controls, operation or maintenance of this unit, please call the Customer Support Department.



Call **1- (330) 220-4MTD (4683)** or **1- (800)-800-7310** to reach a Customer Support representative. Please have your unit's model number and serial number ready when you call. See previous section to locate this information. You will be asked to enter the serial number in order to process your call.

SECTION 1: IMPORTANT SAFE OPERATION PRACTICES



WARNING: This symbol points out important safety instructions which, if not followed, could endanger the personal safety and/or property of yourself and others. Read and follow all instructions in this manual before attempting to operate your tiller. Failure to comply with these instructions may result in personal injury. When you see this symbol— heed its warning.

WARNING: The Engine Exhaust from this product contains chemicals known to the State of California to cause cancer, birth defects or other reproductive harm.

DANGER: Your tiller was built to be operated according to the rules for safe operation in this manual. As with any type of power equipment, carelessness or error on the part of the operator can result in serious injury. This tiller is capable of amputating hands and feet. Failure to observe the following safety instructions could result in serious injury or death.

GENERAL OPERATION

- Read this operator's manual carefully in its entirety before attempting to assemble this machine. Read, understand, and follow all instructions on the machine and in the manual(s) before operation. Be completely familiar with the controls and the proper use of the machine before operating it. Keep this manual in a safe place for future and regular reference and for ordering replacement parts.
- Your tiller is a powerful tool, not a plaything. Therefore, exercise extreme caution at all times. Your unit has been designed to perform one job: to till soil. Do not use it for any other purpose.
- Never allow children under age 14 to operate the unit. Children 14 years and older should only operate the unit under close parental supervision. Only responsible individuals who are familiar with these rules of safe operation should be allowed to use your unit.
- Do not operate tiller while under the influence of alcohol or drugs.
- Keep the area of operation clear of all persons, particularly small children and pets. Stop the engine when they are in the vicinity of your tiller.
- Wear sturdy, rough-soled work shoes and close fitting slacks and shirt. Shirt and slacks that cover the arms and legs and steel-toed shoes are recommended. Do not wear loose fitting clothes or jewelry and secure hair so it is above shoulder length. They can be caught in moving parts. Never operate a unit in bare feet, sandals or sneakers.
- Operate tiller only in daylight or good artificial light.
- Do not start tiller unless the shift lever (if provided) is in the neutral (N) position.
- Do not allow anyone to stand or walk in front of tiller when starting or running engine.
- Do not place feet or hands on or near the tines when starting the engine or while the engine is running.
- Never attempt to make depth bar, tine width, cable, handle, or wheel adjustments while the engine is running.
- Do not leave the tiller unattended with the engine running.
- Before attempting to remove rocks, bricks and other objects from tines, stop the engine and be sure the tines have stopped completely. Disconnect the spark plug wire and move it away from the spark plug.
- If your machine should start making an unusual noise or vibration, immediately stop the engine and allow the machine to come to a complete stop. Disconnect the spark plug wire and move it away from the spark plug. Take the following steps:
 - Inspect for damage.
 - Repair or replace any damaged parts.
 - Check for any loose parts and tighten to assure continued safe operation.
- Muffler and engine become hot and can cause a burn. Do not touch.
- Keep all shields, guards and safety devices in place and operating properly.
- Use caution when tilling near fences, buildings and underground utilities. Rotating tines can cause damage or injury.
- Do not operate engine if air cleaner or cover over carburetor air intake is removed, except for adjustment. Removal of such parts could create a fire hazard.
- Only use accessories approved for this machine by the manufacturer. Read, understand, and follow all instructions provided with the approved accessory.
- If situations occur which are not covered by this manual, use care and good judgment. Contact your dealer for assistance.

CHILDREN

- Tragic accidents can occur if the operator is not alert to the presence of small children. Children are often attracted to the tilling activity. Never assume that children will remain where you last saw them.
- Keep children out of the work area and under the watchful eye of a responsible adult other than the operator.
- Be alert and turn the unit off if a child enters the area.
- Never allow children under the age of 14 to operate the tiller.

SERVICE

- Use extreme care in handling gasoline and other fuels. They are extremely flammable and the vapors are explosive.
- Store fuel and oil in approved containers, away from heat and open flame, and out of the reach of children. Check and add fuel before starting the engine. Never remove gas cap or add fuel while the engine is running. Allow engine to cool at least two minutes before refueling.
- Replace gasoline cap securely and wipe off any spilled gasoline before starting the engine as it may cause a fire or explosion.
- Extinguish all cigarettes, cigars, pipes and other sources of ignition.
- Never refuel unit indoors because flammable vapors will accumulate in the area.

- Never store the machine or fuel container inside where there is an open flame or spark such as a gas hot water heater, space heater, clothes dryer or furnace.
- Never run your machine in an enclosed area as the exhaust from the engine contains carbon monoxide, which is a odorless, tasteless and deadly poisonous gas.
- To reduce fire hazard, keep engine and muffler free of leaves, grass, and other debris build-up. Clean up fuel and oil spillage. Allow unit to cool at least 5 minutes before storing.
- Before cleaning, repairing, or inspecting, make certain the tines and all moving parts have stopped. Disconnect the spark plug wire and keep wire away from spark plug to prevent accidental starting. Do not use flammable solutions to clean air filter.
- We do not recommend the use of pressure washers to clean your unit. They may cause damage to electric components, spindles, pulleys, bearings or the engine. The use of pressure washers will result in shortened life and reduce serviceability.
- Keep all nuts, bolts, and screws tight to be sure the equipment is in safe working condition.
- Never tamper with safety devices. Check their proper operation regularly.
- Do not alter or tamper with the engine's governor setting. The governor controls the maximum safe operating speed of the engine. Overspeeding the engine is dangerous and will cause damage to the engine and to other moving parts of the machine.



WARNING — YOUR RESPONSIBILITY: Restrict the use of this power machine to persons who read, understand and follow the warnings and instructions in this manual and on the machine.

WARNING

TO AVOID INJURY

- READ THE OPERATOR'S MANUAL.
- KNOW LOCATION AND FUNCTIONS OF ALL CONTROLS
- KEEP ALL SAFETY DEVICES AND SHIELDS IN PLACE.
- NEVER ALLOW CHILDREN OR UNINSTRUCTED ADULTS TO OPERATE TILLER.
- SHUT OFF ENGINE BEFORE UNCLOGGING TINES OR MAKING REPAIRS.
- KEEP BYSTANDERS AWAY FROM MACHINE.
- KEEP AWAY FROM ROTATING PARTS.
- USE EXTREME CAUTION WHEN REVERSING OR PULLING THE MACHINE TOWARDS YOU.

WARNING



AVOID INJURY FROM ROTATING TINES - KEEP HANDS, FEET AND CLOTHING AWAY.

SECTION 2: ASSEMBLING YOUR TILLER

This instruction manual covers several different model tillers. Follow only those instructions which pertain to your unit.

To Remove Unit From Carton

- Remove staples, break glue on top flaps, or cut tape at carton end and peel along top flap to open carton.
- Remove loose parts included with unit (i.e., operator's manual, etc.).
- Cut corners and lay carton down flat.
- Remove packing material.
- Roll or slide unit out of carton. Check carton thoroughly for loose parts.
- Extend control cable and lay on the floor. Be careful not to bend or kink control cable.

IMPORTANT: The Engine is shipped **WITHOUT GASOLINE** or **OIL**. After assembly, see separate engine manual for proper fuel and engine oil recommendations.

NOTE: *Left and right is determined from the operator's position, standing behind the tiller.*

Loose Parts In Carton

- (1) Depth Stake
- (1) Handle Assembly
- (1) Shift Rod
- (1) Handle Adjustment Rod (Model 420 series only)

NOTE: *All hardware needed for assembly is attached to the loose parts or the tiller.*

Attaching The Depth Stake Assembly

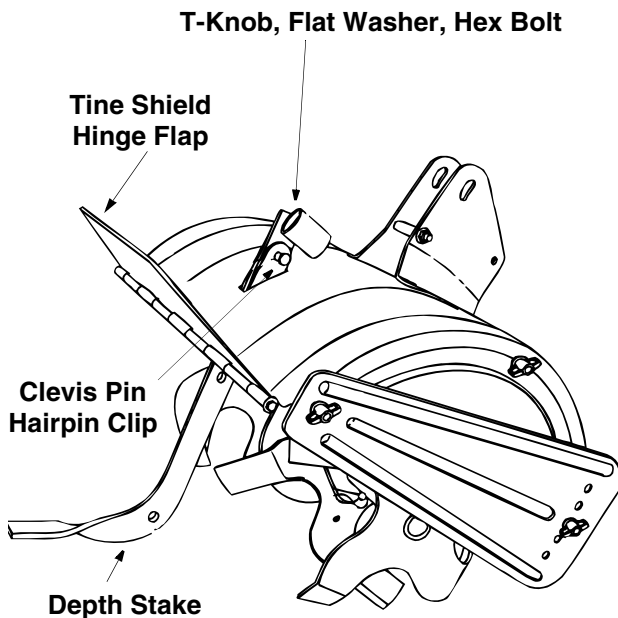

Figure 1

- Tip the tiller forward so it rests on front counterweight.
- Unthread the "T" knob from the top of the depth stake, and remove the flat washer and hex bolt. Remove the hairpin clip from the clevis pin. See Figure 1.
- Raise the tine shield hinge flap assembly. Insert the depth stake assembly in the slot (under the tine shield) and up through the tine shield assembly as shown in Figure 1.
- Insert clevis pin through the tine shield and depth stake assemblies. Secure with hairpin clip.
- Insert hex bolt into the top hole of the depth stake assembly. Place flat washer on the hex bolt and thread "T" knob onto the hex bolt. See Figure 1. Tighten securely.
- Tip the tiller back down so it rests on the tines.

Attaching the Handle Assembly

- Remove the handle adjustment lock, flange nut retainer bracket, shoulder bolt and lock nut from the pivot bracket.
- Place the handle assembly in position in the handle pivot bracket lining the upper holes in the handle with the slots in the pivot bracket. See Figure 2.

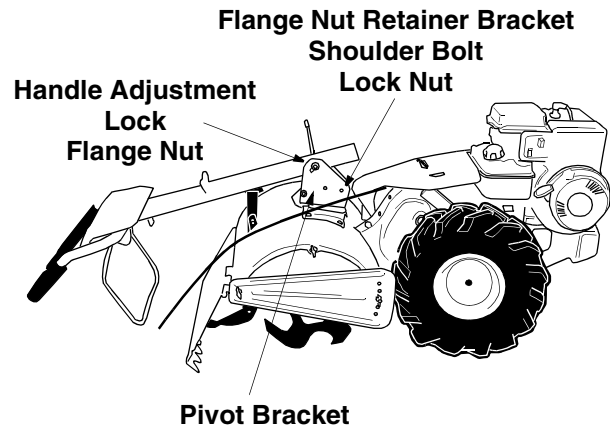

Figure 2

- Lift up the handle assembly and align the bottom holes in the handle assembly with the holes in the pivot bracket. Insert hex bolt (with hex nut retainer attached through the round hole). The head of hex bolt, flange nut retainer bracket should be to the right hand side of the unit. See Figure 3.

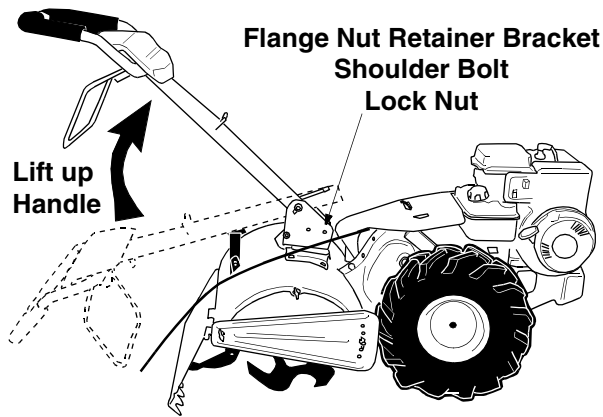

Figure 3

- Place the hex opening of the flange nut retainer bracket over the flange nut securing the handle adjustment lock and install the lock nut on the lower shoulder bolt. See Figure 4.

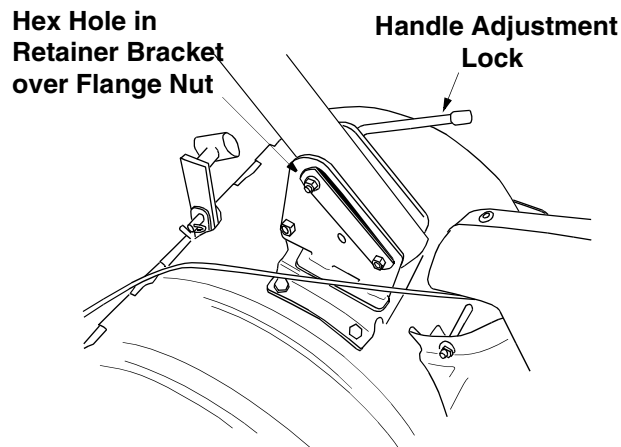

Figure 4

- Pivot handle assembly into position desired. Tighten the bottom bolt and nut securely. Tighten the handle adjustment lock.

Attaching The Gear Shift Rod

NOTE: Model 420 series tiller has two control rods. The gear shift rod is the longer rod.

- Remove the T-handle, nut, hairpin clip, flat washer and rubber washer from the end of the gear shift rod. Slide the rod up through the bracket on the front of the handle assembly (use the right hand hole for Model 420 series). See Figure 5.
- Insert the end of the gear shift rod through the opening in the top of the shift cover, and into the shift bracket. See Figure 6. Secure with rubber washer first, then flat washer and hairpin clip.

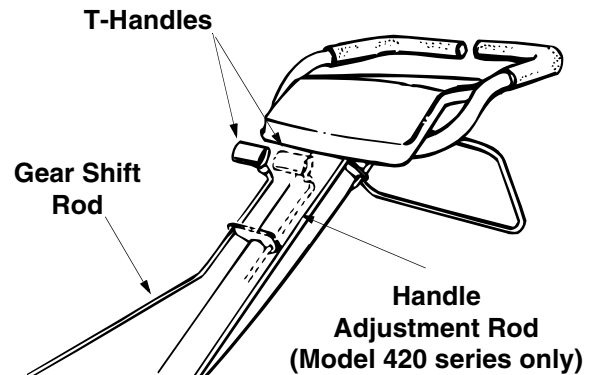

Figure 5

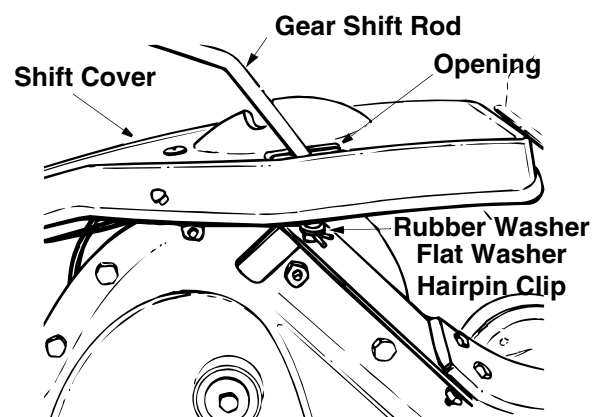

Figure 6

- Install the nut and T-handle on the gear shift rod.

Attaching The Handle Adjustment Rod (Model 420 series only)

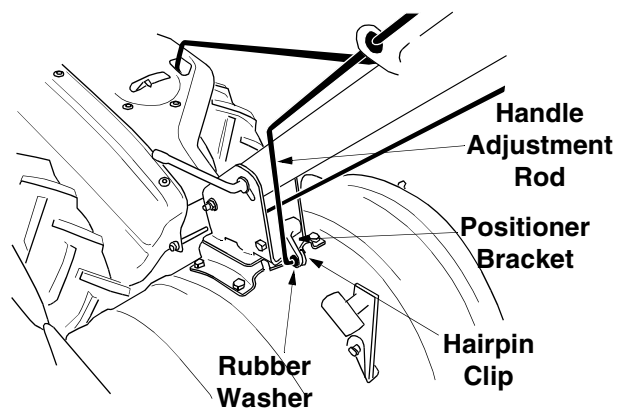

Figure 7

- Remove the T-handle, nut, hairpin clip, and rubber washer from the ends of the handle adjustment rod. Slide the rod up through the left side of the bracket on the front of the handle assembly. Refer to Figure 5.

- Slide the rubber washer on the unthreaded end of the handle adjustment rod. Insert the end of the handle adjustment rod into the positioner bracket beneath the handle, on top of the tine shield. See Figure 7. Secure with hairpin clip.
- Reinstall the nut and T-handle.

Attaching The Clutch Cable

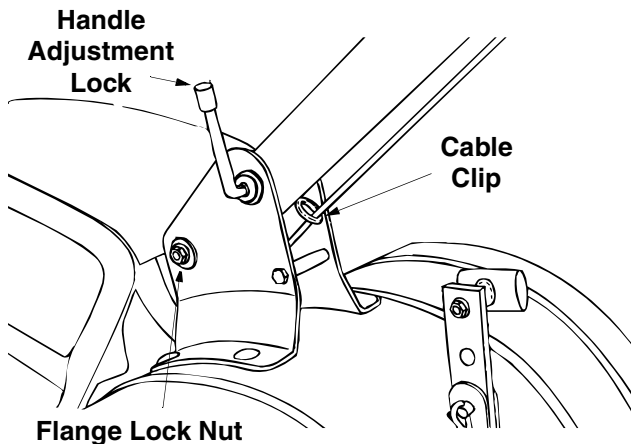

Figure 8

- Route the clutch cable underneath the handle and through the cable clip. Be careful not to bend or kink the cable. Refer to Figure 8. Remove one hex nut from the threaded casing on the end of the cable. See Figure 9.

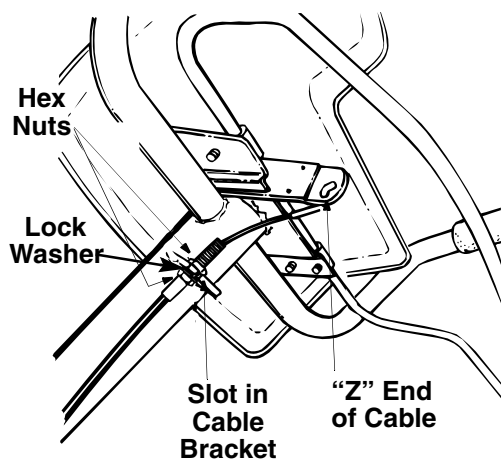

Figure 9 Viewed beneath handle panel.

- Slip the wire up through the slot on the cable bracket underneath the handle. Push the end of the casing up through the cable bracket. Rethread the hex nut on the end of the cable. Do not tighten at this time.
- Pull the cable upwards to obtain slack, and, from right to left, hook the "Z" end of the cable into the bracket on the clutch control (beneath the handle panel) as shown in Figure 9. Tighten the nut against the cable bracket.

NOTE: Do not overtighten control wire. Too much tension may cause it to break.

Final Clutch Adjustment

IMPORTANT: Service the engine with oil and gasoline before checking this adjustment. Refer to the separate engine manual packed with your tiller.

- Position the tiller so the front counterweight is against a solid object, such as a wall. With the gear selection lever in NEUTRAL, start the engine. Refer to Operation section.

NOTE: Keep hands out of belt area while unit is operating.

- Standing on the right side of the tiller, visually examine the belt (inside the belt cover). It should not be turning.
If the belt turns with the unit in neutral, adjust by moving the hex nut below the cable bracket **down** a few turns. See Figure 9. Tighten the upper hex nut against the bracket.
- Now move the shift lever to FORWARD (Wheels Forward) position. Carefully engage the clutch by squeezing the clutch handle against the handle. The wheels should spin.
- **If the wheels do not spin with the unit in forward**, adjust by moving the hex nut which is above the cable bracket **up** a few turns. Tighten the bottom hex nut against the bracket.

Recheck both adjustments, and readjust as necessary. Make certain hex nuts at cable bracket are tight (do not overtighten control cable).

NOTE: If additional adjustment is required, it may be necessary to remove the belt cover, and move the hex nuts at the other end of the clutch cable to increase belt tension.

Tire Pressure

The tires on your unit may be over-inflated for shipping purposes. Reduce the tire pressure before operating the unit. Recommended operating tire pressure is approximately 14 p.s.i. on 14 inch tires and 20 p.s.i. on 16 inch tires. (Check sidewall of tire for tire manufacturer's recommended pressure).



WARNING: Maximum tire pressure under any circumstances is 30 p.s.i. Equal tire pressure should be maintained on both tires.

SECTION 3: KNOW YOUR TILLER

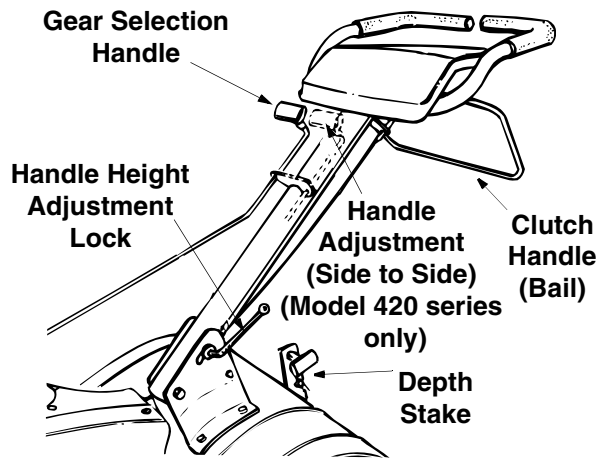

Figure 10

Gear Selection Handle

The gear selection handle is located on the front of the handle assembly (right hand handle on Model 420 Series). It is used to select NEUTRAL, REVERSE, or one of the FORWARD modes.

This tiller is designed for the gear selection handle to be moved while the engine is running. (It will be difficult to obtain all four positions with the engine off.) Pull or push the handle so that the indicator on top of shift cover points to the area of the operating mode desired. See Figure 10.

NOTE: If difficulty is encountered in moving the gear selection handle, refer to following helpful hints. To shift into forward or reverse wheel drive, move tiller forward slightly, then backward, to allow the gears to synchronize.

To shift into forward wheels and tine drive, push forward slightly on the gear selection handle and slowly engage the clutch handle allowing the gears to synchronize. To stop forward movement, and tine drive, release the clutch handle. Do not shift gears with the clutch handle engaged except when engaging the tines.

REVERSE—Reverse wheel drive only.

NEUTRAL—Transmission is in neutral.

FORWARD Modes:

Wheels Forward— Forward wheel drive only.

Tines Reverse— Forward wheel drive and reverse tine drive.



WARNING: Make certain unit is in NEUTRAL when starting the engine.

Clutch Handle - (Bail)

The clutch handle (bail) is located beneath the handle. See Figure 10. Squeezing the clutch handle against the handle engages the wheel and tine drive mechanisms.

Throttle Control (All Engines)

The throttle control lever is located on the engine. It controls the engine speed and stops the engine. See Figure 11.

Choke Lever (Brigg & Stratton Standard and Intek Engines)

The choke lever is located by the throttle. It is used to enrich the fuel mixture in the carburetor when starting a cold engine. See Figure 11.

Primer Button (Tecumseh Engine Only)

The primer button is located behind the air cleaner. It is used to enrich the fuel mixture in the carburetor when starting a cold engine. See Figure 11.

Depth Stake

The depth stake controls the tilling depth. Refer to "Setting the Depth" on page 10.

Handle Adjustment (See Figure 10)

The handle may be adjusted to the height desired. Loosen the handle height adjustment lock a few turns. Pivot handle up or down to desired position. Tighten lock.

On Model 420 series, the handle may also be adjusted to be in line with the tiller, or swung to the left or right so the operator is not walking in the freshly tilled soil. To adjust the handle position from side to side, pull the handle adjustment handle back, pivot the tiller handle to desired position and release the handle.

Fuel Shut-Off Valve (Briggs & Stratton Intek Engine if equipped)

Make sure the valve is in the On (horizontal) position when starting the unit. Any time the tiller is not in operation (i.e., storing, performing maintenance or adjustment), make sure the valve is in the OFF (vertical) position.

SECTION 4: OPERATING YOUR TILLER

NOTE: Engine is shipped without oil.

Before Starting

- **Service engine with oil** as instructed in the separate engine manual packed with your unit.
- Fill fuel tank with clean, fresh, lead-free.

To Start Engine

NOTE: When pushing the unit with the engine off, you will hear a ratcheting sound (gear noise) which is normal.



WARNING: Be sure no one is standing in front of the tiller while the engine is running or being started.

Briggs and Stratton Standard

- Place gear selection lever in NEUTRAL.
- Place the throttle control lever in FAST position. See Figure 11.
- Move choke lever to CHOKE position.

NOTE: A warm engine may not require choking.

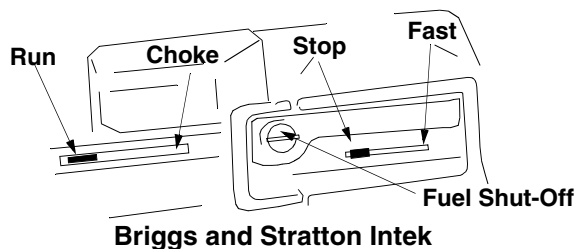

Briggs and Stratton Intek

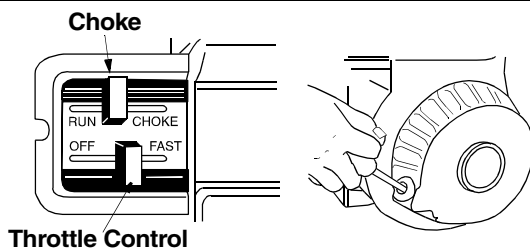

Throttle Control

Briggs and Stratton Standard

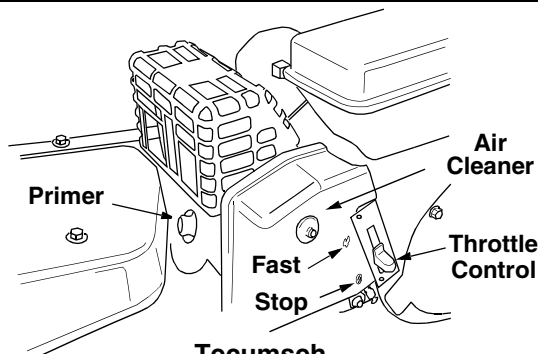

Tecumseh
Figure 11

- Stand at side of tiller. Grasp the starter handle and pull out slowly, until it pulls slightly harder. Let rope rewind slowly.
- Pull starter handle rapidly. Do not allow handle to snap back. Allow it to rewind slowly while keeping a firm hold on the starter handle.
- Repeat steps 4 and 5 until engine starts.
- As engine warms up and begins to operate evenly, move choke lever gradually to RUN position. If engine falters, return to choke position, then slowly move to RUN position. Refer to engine manual for additional engine information.

Tecumseh Engines

- Place gear selection lever in NEUTRAL.
- Place the engine speed control in the START position.
- Push primer two (2) or three (3) times (see Figure 11). Wait about two (2) seconds between each push.

NOTE: Primer may not be needed to restart a warm engine after a short shutdown.

- Stand at side of tiller. Grasp the starter handle and pull out slowly, until it pulls slightly harder. Let rope rewind slowly.
- Pull rope with a rapid full arm stroke. Do not allow handle to snap back. Allow it to rewind slowly while keeping a firm hold on the starter handle.

NOTE: If engine fails to start after three (3) pulls, push primer two (2) times and pull starter rope again.

- Repeat steps 4 and 5 until engine starts. Refer to engine manual for additional engine information.

NOTE: After starting and prior to using the tiller for the first time, be certain to check the clutch adjustment as described in "Checking the Clutch Adjustment" section of the Assembly Instructions.

To Stop Engine

- Move throttle control to STOP or OFF position.
- Disconnect spark plug wire and ground to prevent accidentally starting while equipment is unattended.

NOTE: After the first ten hours of operation, recheck the clutch adjustment. Refer to final clutch adjustment in Assembly Instructions.



WARNING: When operating the tiller for the first time, use the depth stake setting that gives 1 inch of tilling depth (second hole from the top). Refer to Figure 12.

Setting The Depth

Tilling depth is controlled by the depth stake which can be adjusted to five different settings. See Figure 12. Adjust the side shields as shown in Figure 13, as you adjust the depth stake. Be certain spark plug wire is disconnected and grounded against the engine.

- When using the tiller for the first time, use the second adjustment hole from the top (1" of tilling depth). See Figure 12.

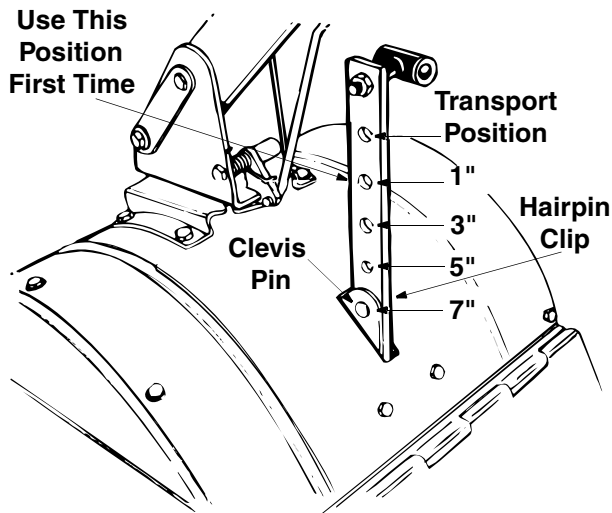

Figure 12

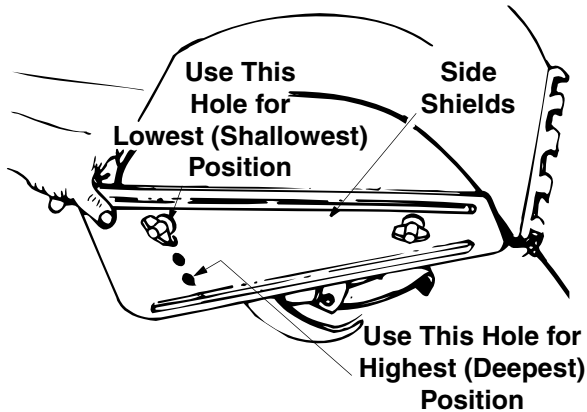

Figure 13

- When breaking up sod and for shallow cultivation, use the setting which gives 1" of tilling depth (second hole from the top). Place the side shields in their lowest position. For further depth, raise the

depth stake and side shields and make one or two more passes over the area.

- When tilling loose soil, depth stake may be raised to its highest position (use bottom adjustment hole) to give the deepest tilling depth. Raise the side shields to their highest position.
- To transport tiller, lower the depth stake (use top adjustment hole).

To adjust the depth stake, remove the clevis pin and hairpin clip. See Figure 12. Move the depth stake to the desired setting. Secure with the clevis pin and hairpin clip.

To adjust the side shields, remove the wing nuts. See Figure 13. Move the side shield to the desired position. Replace the wing nuts. Tighten securely.

Operating the Tiller

- Select the depth stake setting.
- Start engine as instructed on page 9.
- Move gear selection handle to one of the forward modes or reverse.



WARNING: Do not move the gear selection handle with the wheels or tines engaged. Make certain the unit is stopped completely before changing the gear selection. A partial engagement may be necessary when engaging tines. Refer to "Know Your Tiller" section on page 8.

- Squeeze the clutch handle against the handle to engage the wheels and tines.

NOTE: Make certain the gear selection indicator is correctly positioned before engaging the clutch handle. If it is between gears, the engine will stall.

To transport tiller, **do not** engage the tines. Select the wheel drive only.



WARNING: Do not push down on the handles so that the wheels are lifted off the ground while using the tine drive, or the tiller could move backward and cause personal injury.

For best results, it is recommended the garden be tilled twice (lengthwise, then widthwise) to pulverize the soil.

SECTION 5: MAKING ADJUSTMENTS

Handle Adjustment

The handle height may be adjusted. On Model 420 series, the handle may also be adjusted to be in line with the tiller, or swung to the left or right. Refer to the handle adjustment on page 8 for details of handle adjustment.

Belt Tension Adjustment

Periodic adjustment of the belt tension may be required due to normal stretch and wear on the belt. Adjustment is needed if the tines or wheels seem to hesitate while turning, but the engine maintains the same speed.

To adjust the tension on the belt, refer to final clutch adjustment in Assembly Instructions.

Carburetor Adjustment



WARNING: If any adjustments are made to the engine while the engine is running, (e.g. carburetor), disengage all clutches and tines. Keep clear of all moving parts.

Be careful of heated surfaces and muffler.

Never make unnecessary adjustments. The factory settings are correct for most applications. If adjustments are needed, refer to the separate engine manual packed with your tiller.

SECTION 6: SERVICE

Transmission—The transmission is pre-lubricated and sealed at the factory. It requires no checking unless the transmission is disassembled. To fill with grease, lay the right half of the transmission on its side. Add 22 ounces of Benalene 920 grease. Assemble the left half to it. This grease can be obtained at your nearest authorized dealer. Order part number 737-0300.

Clutch Handle—Lubricate the pivot point on the clutch handle and the cable at least once a season with light oil. The control must operate freely in both directions.

Pivot Points—Lubricate all pivot points and linkages at least once a season with light oil.

Tine Shafts—Remove tine assemblies and lubricate the tine shafts at least once a season.

Wheel Shafts—Remove wheel assemblies and lubricate the axle shafts at least once a season.

SECTION 7: MAINTAINING YOUR TILLER



WARNING: Disconnect the spark plug wire and ground it against the engine before performing any repairs or maintenance.

Engine

Refer to the separate engine manual for engine maintenance instructions.

Maintain **engine oil** as instructed in the separate engine manual packed with your unit. Read and follow instructions carefully.

Service **air cleaner** every ten hours under normal conditions. Clean every hour under extremely dusty conditions. Poor engine performance and flooding usually indicates that the air cleaner should be serviced. To service the air cleaner, refer to the separate engine manual packed with your unit.

IMPORTANT: Never run your engine without air cleaner completely assembled.

The **spark plug** should be cleaned and the gap reset every 25 hours of engine operation. Spark plug replacement is recommended at the start of each tiller season; check engine manual for correct plug type and gap specification.

Clean the engine regularly with a cloth or brush. Keep the cooling system (blower housing area) clean to permit proper air circulation which is essential to engine performance and life. Be certain to remove all dirt and combustible debris from muffler area.

Cleaning The Tine Area

Clean the underside of the tine shield after each use. The dirt washes off the tines easier if rinsed off immediately instead of after it dries. Always towel dry the tiller afterwards and apply a light coat of oil or silicone to prevent rusting or water damage.

IMPORTANT: Never use a "pressure" washer to clean your tiller. Water can penetrate tight areas of the tiller and its chaincase and cause serious damage to the unit.

Tires

Recommended operating tire pressure is approximately 14 p.s.i. on 14 inch tires and 20 p.s.i. on 16 inch tires. (Check sidewall of tire for tire manufacturer's recommended pressure). Maximum tire pressure under any circumstances is 30 p.s.i. Equal tire pressure should be maintained on both tires.

When installing a tire to the rim, be certain rim is clean and free of rust. Lubricate both the tire and rim generously. Never inflate to over 30 p.s.i. to seat beads.



WARNING: Excessive pressure (over 30 p.s.i.) when seating beads may cause tire/rim assembly to burst with force sufficient to cause serious injury.

Belt Replacement



CAUTION: Do not use an off-the-shelf belt.

Your tiller has been engineered with a belt made of special material (Kevlar Tensile) for longer life and better performance. It should not be replaced with an off-the-shelf belt.

If belt replacement is required, order belt or belts by part number from your nearest authorized dealer.

Part No. 754-0438—"V" Belt

- Disconnect and ground the spark plug wire against the engine.
- Remove the belt cover from the left side of the tiller as follows:
- Remove two torx head screws from the top of belt cover.
- Remove two hex cap nuts and flat washers from front side of the belt cover. Remove the hex nut and flat washer at the back of the cover.
- Remove the belt keeper assembly located behind the engine pulley by removing two hex bolts and lock washers. See Figure 14.

- Remove belt. Reassemble new belt, following instructions in reverse order.

NOTE: Upon reassembly, make certain the belt is routed over the idler pulley and inside of belt keepers by engine pulley. See Figure 14.

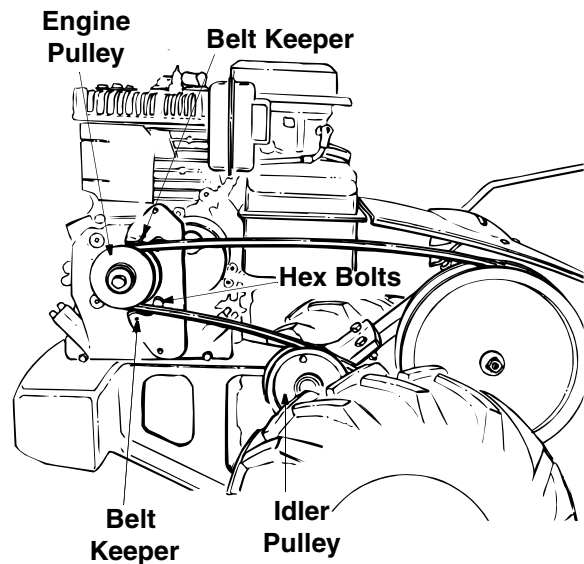

Figure 14

SECTION 8: OFF-SEASON STORAGE

If the tiller will not be used for a period longer than 30 days, the following steps should be taken to prepare the tiller for storage.

- Clean the exterior of engine and the entire tiller thoroughly. Lubricate the tiller as described in the lubrication instructions.
- We do not recommend the use of pressure washers to clean your unit. They may cause damage to electric components, spindles, pulleys, bearings or the engine. The use of pressure washers will result in shortened life and reduce serviceability.

- Refer to the engine manual for correct engine storage instructions.
- Wipe tines with oiled rag to prevent rust.
- Store tiller in a clean, dry area. Do not store next to corrosive materials, such as fertilizer.

NOTE: When storing any type of power equipment in an unventilated or metal storage shed, care should be taken to rustproof the equipment. Using a light oil or silicone, coat the equipment, especially any springs, bearings and cables.

SECTION 9: TROUBLE SHOOTING GUIDE

Trouble	Possible Cause(s)	Corrective Action
Engine fails to start	Fuel tank empty, or stale fuel. Throttle control lever not in correct starting position (if so equipped). Blocked fuel line. Dirty aircleaner. Choke not in ON position. Spark plug wire disconnected. Faulty spark plug. Engine flooded.	Fill tank with clean, fresh gasoline. Fuel will not last over thirty days unless a fuel stabilizer is used. Move throttle lever to start position. Clean fuel line. Refer to the engine manual packed with your unit. Move switch to ON position. Connect wire to spark plug. Clean, adjust gap or replace. Refer to the engine manual packed with your unit.
Engine runs erratic	Unit running on CHOKE. Spark plug wire loose. Blocked fuel line or stale fuel. Vent in gas cap plugged. Water or dirt in fuel system. Dirty air cleaner. Carburetor out of adjustment.	Move choke lever to OFF position. Connect and tighten spark plug wire. Clean fuel line; fill tank with clean, fresh gasoline. Fuel will not last over thirty days unless a fuel stabilizer is used. Clear vent. Drain fuel tank. Refill with fresh fuel. Refer to the engine manual packed with your unit. Refer to the engine manual packed with your unit.
Engine over-heats	Engine oil level low. Dirty air cleaner. Air flow restricted. Carburetor not adjusted properly.	Fill crankcase with proper oil. Refer to the engine manual packed with your unit. Refer to the engine manual packed with your unit. Adjust carburetor as instructed in separate engine manual.
Tines do not engage	Foreign object lodged in tines. Tine clevis pin(s) missing. Pulley and idler not in correct adjustment. Not shifting properly. Control cable not adjusted properly. Belt worn and/or stretched.	Dislodge foreign object. Replace tine clevis pin(s). Take unit to authorized service dealer. Refer to controls section of operator's manual for proper shifting procedures. Adjust control cable (see assembly instructions). Replace belt.
Wheels do not engage	Clevis pin missing. Tiller is not being shifted properly. Control cable not adjusted properly. Belt worn and/or stretched.	Replace clevis pin. Refer to controls section of operator's manual for proper shifting procedures. Adjust control cable (see assembly instructions). Replace belt.

NOTE: For repairs beyond the minor adjustments above, contact your local authorized service dealer.

Models 410 Series

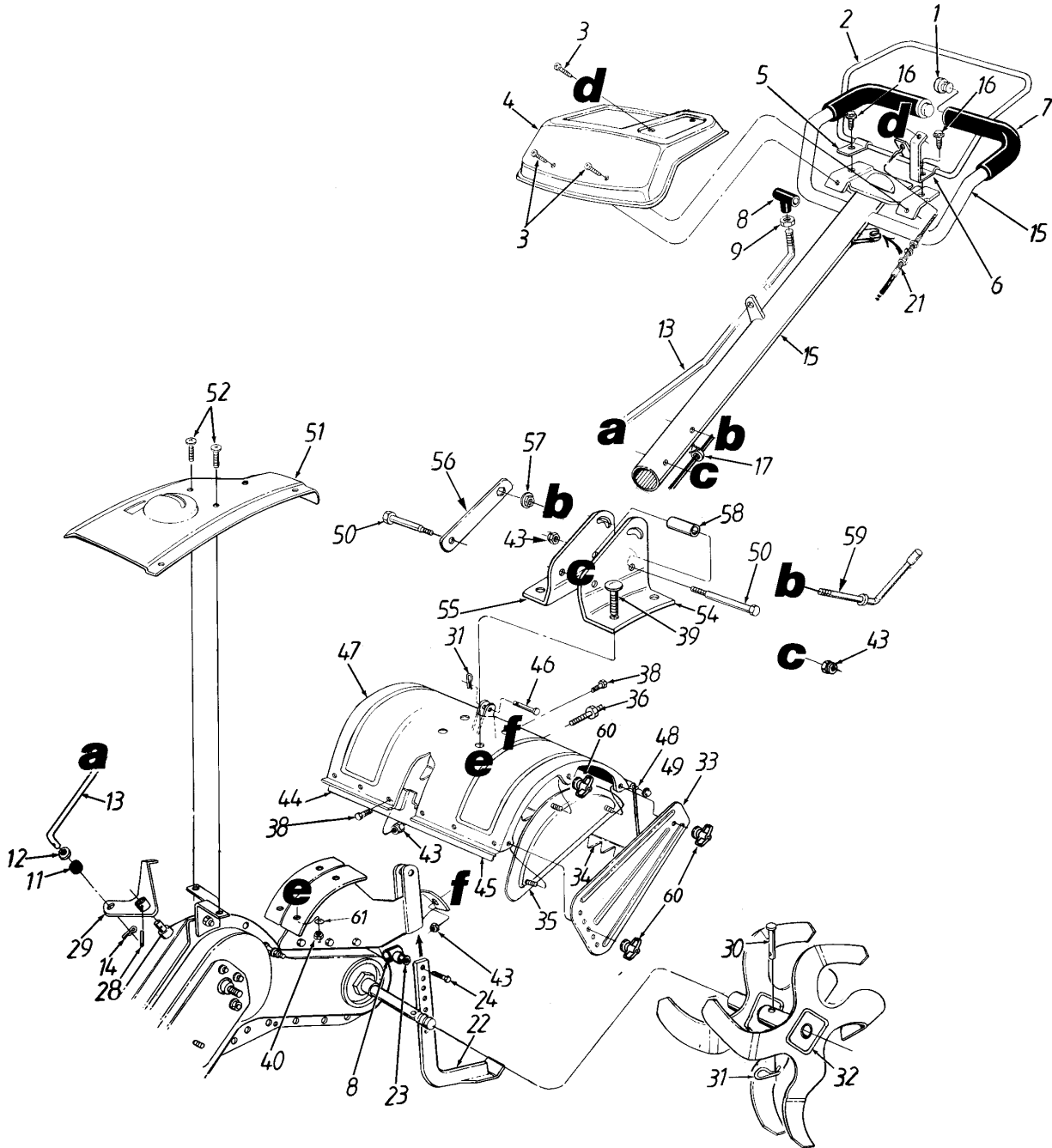

Models 410 Series

REF. NO.	PART NO	DESCRIPTION	REF. NO.	PART NO	DESCRIPTION
1	735-0246	Vinyl End Plug	33	786-0090	Side Shield
2	647-0014	Clutch Control Ass'y.	34	786-0113	Rear Tine Shield
3	710-1017	Torx Mach. AB-Tap Scr. 1/4 x .62" Lg.	35	686-0044A	End Cover Ass'y.
4	786-0131	Handle Cover	36	738-0849	Hex Cap Bolt 5/16-18 x 1.25"
5	786-0098	Retaining Brkt.—R.H.	38	710-0376	Hex Bolt 5/16-18 x .75" Lg.
6	786-0118	Retaining Brkt.—L.H.	39	710-3097	Carriage Bolt 3/8-16 x 1" Lg.
7	720-0278A	Grip (2 Req'd.)	40	712-0798	Hex Ins. L-Nut 3/8-16 Thd.
8	720-0210A	Knob	43	712-3004A	Hex Flange Top L-Nut 5/16-18 Thd.
9	712-3008	Hex Jam Nut 3/8-16 Thd.	44	786-0076	Tine Shield Brkt.—R.H.
11	735-0127	Rubber Washer	45	786-0077	Tine Shield Brkt.—L.H.
12	736-0204	Fl-Wash. .344" I.D. x .6" O.D.	46	711-0415	Clevis Pin .375" Dia.
13	747-0902	Gear Shift Rod	47	786-0085	Tine Shield
14	714-0104	Hairpin Clip	48	747-0432	Tiller Flap Rod
15	649-0017	Handle Ass'y.	49	726-0106	Cap Speed Nut
16	710-0896	Tap Scr. 1/4-14 x 5/8" Lg.	50	710-0189	Hex Bolt 5/16-18 x 3" Lg.
17	726-0330	Cable Clip	51	786-0101B	Shift Cover (410, 412 & 422)
21	746-0916	Clutch Cable		786-0168	Shift Cover (415 & 417)
22	786-0120	Depth Bar	52	710-1017	Torx Mach. AB-Tap Scr. 1/4 x
23	736-0117	Fl-Wash. 3/8" I.D. x 5/8" O.D.	54	786-0109	Handle Brkt.—L.H.
24	710-0253	Hex Bolt 3/8-16 x 1" Lg.*	55	786-0108	Handle Brkt.—R.H.
28	715-0120	Spiral Pin 3/16" x 1"	56	784-0191	Hex Nut Retainer Brkt.
29	686-0095	Shift Crank Ass'y.	57	712-0379	Hex Flange Nut 3/8-24 Thd.
30	711-0415	Clevis Pin	58	750-0885	Spacer .322 Dia.
31	714-0149B	Hairpin Clip	59	784-0190	Handle Adjustment Crank
32	642-0015	Tine Ass'y.—L.H.	60	712-0421	Knob 5/16-18 Thd.
	642-0016	Tine Ass'y.—R.H. (Not Shown)	61	736-0169	L-Washer 3/8" I.D.

NOTE: For **painted parts**, please refer to the list of color codes below. Please add the applicable color code, wherever needed, to the part number to order a replacement part. For instance, if a part numbered 700-xxxx is painted Oyster Gray, the part number to order would be 700-xxxx-0662.

Black — 0691; Black, Powder — 0637; Blue, Midnight — 0667; Charcoal — 0483; Grey — 0648;
Grey, Oyster — 0662; Orange — 0606; Red — 0650; Red, MTD — 0638; Silver — 0629; Yellow — 0674.

Models 410 & 420 Series

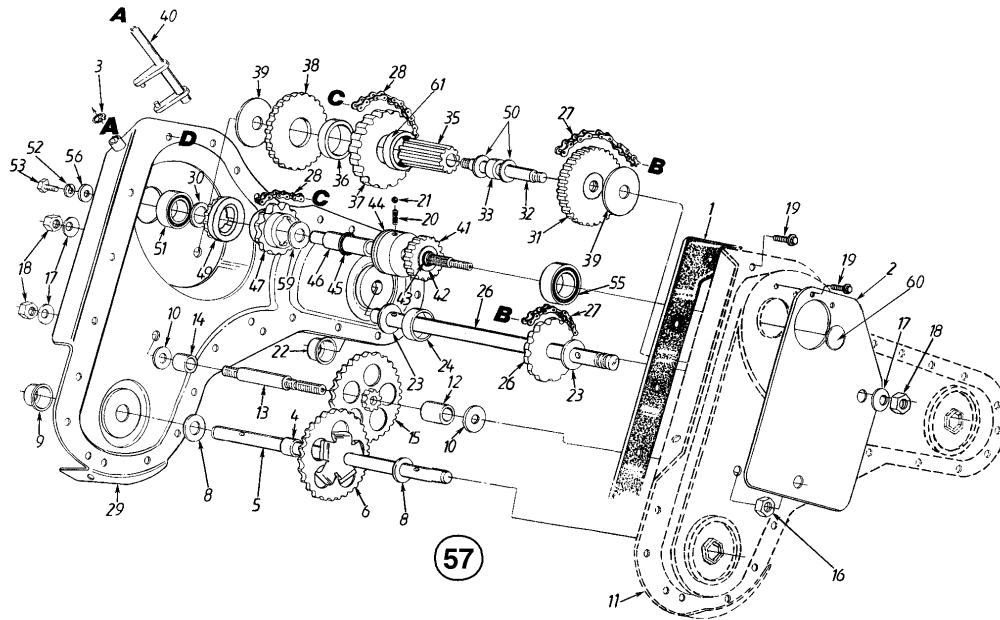

REF. NO.	PART NO.	DESCRIPTION	REF. NO.	PART NO.	DESCRIPTION
1	721-0295	Chain Case Gasket	30	736-0541	Fl-Wash. 7/16" I.D. x 1-3/8" O.D.
2	786-0086	Reinforcement Plate	31	617-0002	Gear and Sprocket Ass'y.
3	716-0865	Snap Ring	32	738-0884	Jack Shaft 5" Lg.
4	750-0938	Spacer .735" I.D. x .886" O.D.	33	750-0931	Spacer .636" I.D. x .86" O.D.
5	611-0058	Wheel Shaft	35	717-1411	Spur Gear 10T
6	717-1458	Spur Gear 46T	36	750-0930	Spacer 1.5" I.D. x 1.76" O.D.
8	736-0351	Fl-Wash. .76" I.D. x 1.5" O.D.	37	713-0436	Sprocket—#41 Chain
9	721-0379	Shaft Seal	38	717-1405	Reverse Gear 46T
10	736-0518	Thr.Wash..445 I.D.x1.92 O.D.x	39	736-0518	Thrust Wash. .445" I.D. x 1.92"
11	686-0039	Gear Case Ass'y. Half—L.H.	40	618-0245B	Shifter Ass'y.
12	750-0935	Spacer .635" I.D. x 1" O.D. x .78	41	717-1409	Spur Gear 17T
13	738-0885	Jack Shaft 2.06" Lg.	42	736-0442	Fl-Wash. .69" I.D. x 1.06" O.D.
14	750-0936	Spacer .635" I.D. x 1" O.D. x .37" Thk.	43	732-0614	Wire Collar
15	617-0004	Gear Idler Ass'y.	44	718-0234	Clutch Collar
16	712-3067	Hex Patch L-Nut 7/16-20 Thd.	45	716-0235	Retaining Ring .875" Shaft
17	736-0407	Bell-Wash. .45" I.D. x 1" O.D.	46	711-1087	Drive Shaft
18	712-0378	Hex Nut 7/16-20 Thd.	47	713-0435	Sprocket 11T
19	710-0896	Hex Wash. Hd. TT-Tap Scr. 1/4-20 x .5" Lg.	49	717-1451A	Spur Gear 16T
20	732-0863	Spring Detent	50	736-0336	Fl-Wash. 5/8" I.D. x 1" O.D.
21	741-0862	Ball Detent	51	741-0124	Ball Bearing .669" I.D.
22	721-0378	Shaft Seal	52	736-0329	L-Wash. 1/4" I.D.
23	736-0163	Thrust Wash. 1.03" I.D. x 1.62"	53	710-0258	Hex Bolt 1/4-20 x .62" Lg.
24	750-0570	Spacer 1" I.D. x 2" O.D. x .5" Thk.	55	741-0563	Ball Bearing
26	611-0021	Tine Shaft Ass'y.	56	736-0512	Fl-Wash. .281" I.D. x .875" O.D.
27	713-0226	Chain #50 5/8" Pitch x 52 Links—Endless	57	686-0094	Gear Case Ass'y. Comp.
28	713-0233	Chain—#41 1/2" Pitch x 30 Links—Endless	58	718-0237	Key—Drive Shaft (Not Shown)
29	686-0038	Gear Case Ass'y. Half—R.H.	59	736-0265	Fl-Wash. .88" I.D. x 1.5" O.D.
			60	726-0331	Button Plug
			61	750-0987	Spacer 1.52" I.D.
			—	737-0300	Grease (40 oz. Req'd.)

Model 420 Series

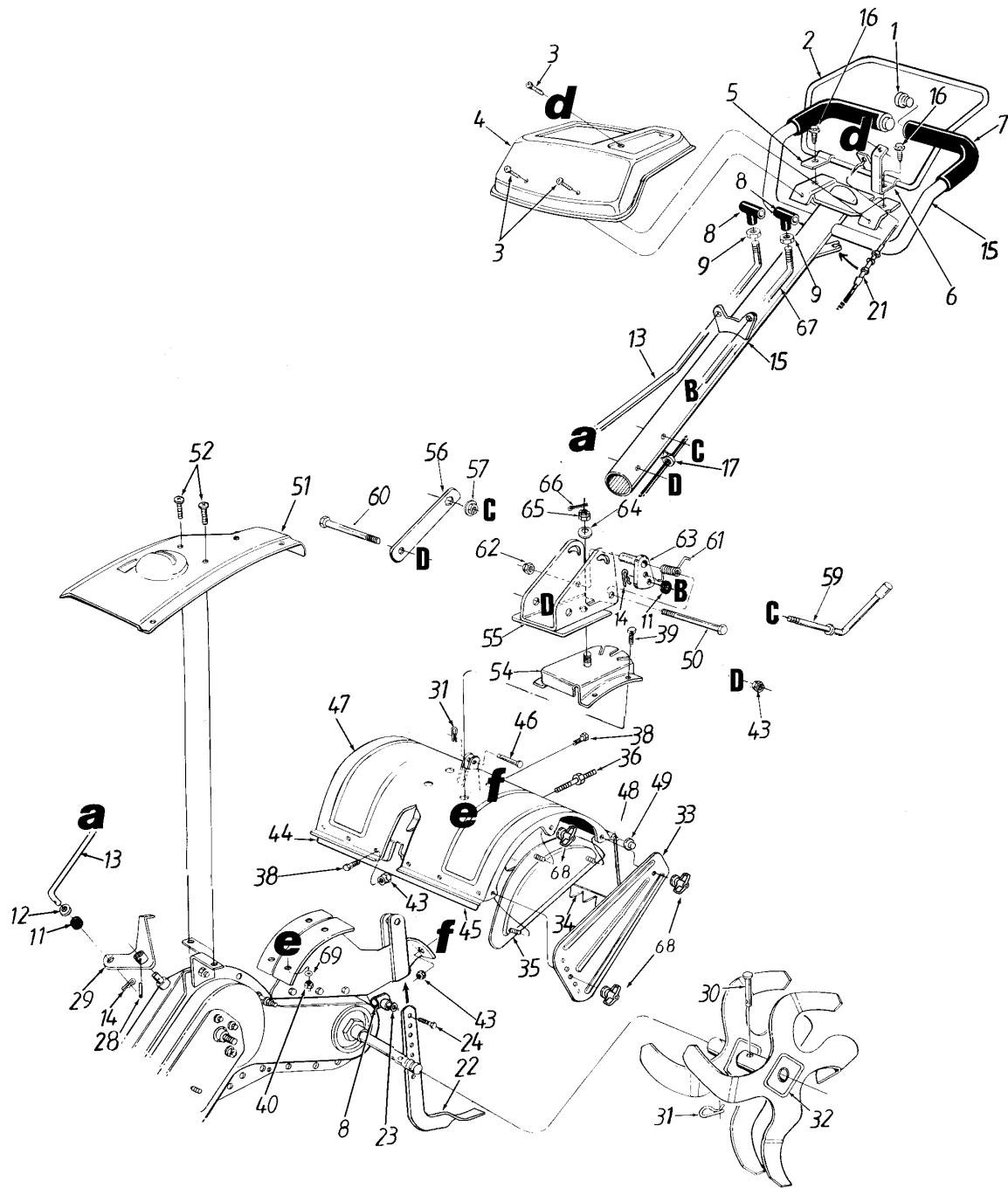

Model 420 Series

REF. NO.	PART NO.	DESCRIPTION	REF. NO.	PART NO.	DESCRIPTION
1	735-0246	Vinyl End Plug	38	710-3008	Hex Bolt 5/16-18 x .75" Lg.
2	647-0014	Clutch Control Ass'y.	39	710-3097	Carriage Bolt 3/8-16 x 1" Lg.
3	710-1017	Torx Mach. AB-Tap Scr.	40	712-0798	Hex Nut 3/8-16 Thd.
4	786-0131	Handle Cover	43	712-3004A	Hex Fl. Tp. L-Nut 5/16-18 Thd.
5	786-0098	Retaining Brkt.—R.H.	44	786-0076	Tine Shield Brkt.—R.H.
6	786-0118	Retaining Brkt.—L.H.	45	786-0077	Tine Shield Brkt.—L.H.
7	720-0278A	Grip (2 Req'd.)	46	711-0415	Clevis Pin .375" Dia.
8	720-0210A	Knob	47	786-0085	Tine Shield
9	712-3008	Hex Jam Nut 3/8-16 Thd.	48	747-0432	Tiller Flap Rod
11	735-0127	Rubber Washer	49	726-0106	Cap Speed Nut
12	736-0204	Fl-Wash. .344" I.D. x .6" O.D.	50	710-0521	Hex Bolt 3/8-16 x 3" Lg.
13	747-0902	Gear Shift Rod	51	786-0101B	Shift Cover
14	714-0104	Hairpin Clip	52	710-1017	Torx Mach. AB-Tap Scr. 1/4 x .6"
15	649-0016	Handle Ass'y.	54	686-0071	Handle Positioner Brkt. Ass'y.
16	710-0896	Tap Scr. 1/4-14 x 5/8" Lg.	55	686-0048	Handle Pivot Brkt. Ass'y.
17	726-0330	Cable Clip	56	784-0191	Hex Nut Retainer Brkt.
21	746-0916	Clutch Cable	57	712-0379	Hex Flange Nut 3/8-24 Thd.
22	786-0120	Depth Bar	59	784-0190	Handle Adjustment Crank
23	736-0117	Fl-Wash. 3/8" I.D. x 5/8" O.D.	60	710-0189	Hex Bolt 5/16-18 x 3" Lg.
24	710-0514	Hex Bolt 3/8-16 x 1" Lg.*	61	732-0493	Torsion Spring
28	715-0120	Spiral Pin 3/16" x 1"	62	712-0375	Hex L-Nut 3/8-16 Thd.
29	686-0095	Shift Crank Ass'y.	63	748-0375	Handle Swing Link
30	711-0415	Clevis Pin	64	736-0317	Bell-Wash. 5/8" I.D.
31	714-0149B	Hairpin Clip	65	712-0386A	Hex Slotted Nut 5/8-18 Thd.
32	642-0015	Tine Ass'y.—L.H.	66	714-3021	Cotter Pin 1/8" x 1-5/8"
	642-0016	Tine Ass'y.—R.H. (Not Shown)	67	747-0901	Handle Adjustment Rod
33	786-0090	Side Shield	68	712-0421	Knob 5/16-18 Thd.
34	786-0113	Rear Tine Shield	69	736-0169	L-Washer 3/8" I.D.
35	686-0044A	End Cover Ass'y.			
36	738-0849	Hex Screw 5/16-18 x .75" Lg.			

NOTE: For **painted parts**, please refer to the list of color codes below. Please add the applicable color code, wherever needed, to the part number to order a replacement part. For instance, if a part numbered 700-xxxx is painted Oyster Gray, the part number to order would be 700-xxxx-0662.

Black — 0691; Black, Powder — 0637; Blue, Midnight — 0667; Charcoal — 0483; Grey — 0648;
Grey, Oyster — 0662; Orange — 0606; Red — 0650; Red, MTD — 0638; Silver — 0629; Yellow — 0674.

MANUFACTURER'S LIMITED WARRANTY FOR:



The limited warranty set forth below is given by MTD PRODUCTS INC ("MTD") with respect to new merchandise purchased and used in the United States, its possessions and territories.

MTD warrants this product against defects in material and workmanship for a period of two (2) years commencing on the date of original purchase and will, at its option, repair or replace, free of charge, any part found to be defective in material or workmanship. This limited warranty shall only apply if this product has been operated and maintained in accordance with the Operator's Manual furnished with the product, and has not been subject to misuse, abuse, commercial use, neglect, accident, improper maintenance, alteration, vandalism, theft, fire, water or damage because of other peril or natural disaster. Damage resulting from the installation or use of any accessory or attachment not approved by MTD Products Inc. for use with the product(s) covered by this manual will void your warranty as to any resulting damages.

Normal wear parts or components thereof are subject to separate terms as follows: All normal wear part or component failures will be covered on the product for a period of 90 days regardless of cause. After 90 days, but within the two year period, normal wear part failures will be covered ONLY IF caused by defects in material or workmanship of OTHER component parts. Normal wear parts and components include, but are not limited to, belts, blades, blade adapters, grass bags, rider deck wheels, seats, snow thrower skid shoes, shave plates and tires. Batteries are covered by a 90-day limited replacement warranty.

HOW TO OBTAIN SERVICE: Warranty service is available, WITH PROOF OF PURCHASE THROUGH YOUR LOCAL AUTHORIZED SERVICE DEALER. To locate the dealer in your area, please check for a listing in the Yellow Pages or contact the Customer Service Department of MTD PRODUCTS INC by calling 1-800-800-7310 or writing to P.O. Box 368022, Cleveland, Ohio 44136-9722.

This limited warranty does not provide coverage in the following cases:

- a. The engine or component parts thereof. These items carry a separate manufacturer's warranty. Please refer to the applicable manufacturer's warranty on these items.
- b. Log splitter pumps, valves and cylinders have a separate one year warranty.

- c. Routine maintenance items such as lubricants, filters, blade sharpening and tune-ups, or adjustments such as brake adjustments, clutch adjustments or deck adjustments; and normal deterioration of the exterior finish due to use or exposure.

- d. MTD does not extend any warranty for products sold or exported outside of the United States of America, its possessions and territories, except those sold through MTD's authorized channels of export distribution.

No implied warranty, including any implied warranty of merchantability or fitness for a particular purpose, applies after the applicable period of express written warranty above as to the parts as identified. No other express warranty or guaranty, whether written or oral, except as mentioned above, given by any person or entity, including a dealer or retailer, with respect to any product shall bind MTD. During the period of the Warranty, the exclusive remedy is repair or replacement of the product as set forth above. (Some states do not allow limitations on how long an implied warranty lasts, so the above limitation may not apply to you.)

The provisions as set forth in this Warranty provide the sole and exclusive remedy arising from the sales. MTD shall not be liable for incidental or consequential loss or damages including, without limitation, expenses incurred for substitute or replacement lawn care services, for transportation or for related expenses, or for rental expenses to temporarily replace a warranted product. (Some states do not allow the exclusion or limitation of incidental or consequential damages, so the above exclusion or limitation may not apply to you.)

In no event shall recovery of any kind be greater than the amount of the purchase price of the product sold. Alteration of the safety features of the product shall void this Warranty. You assume the risk and liability for loss, damage, or injury to you and your property and/or to others and their property arising out of the use or misuse or inability to use the product.

This limited warranty shall not extend to anyone other than the original purchaser, original lessee or the person for whom it was purchased as a gift.

How State Law Relates to this Warranty: This limited warranty gives you specific legal rights, and you may also have other rights which vary from state to state.

Free Manuals Download Website

<http://myh66.com>

<http://usermanuals.us>

<http://www.somanuals.com>

<http://www.4manuals.cc>

<http://www.manual-lib.com>

<http://www.404manual.com>

<http://www.luxmanual.com>

<http://aubethermostatmanual.com>

Golf course search by state

<http://golfingnear.com>

Email search by domain

<http://emailbydomain.com>

Auto manuals search

<http://auto.somanuals.com>

TV manuals search

<http://tv.somanuals.com>