

# NAGRA ARES-P II MANUAL



Version: August 18 2004

**WARNING:** The ARES-P/RCX220/ARES-P II has a built-in charger (charge current = 100 mA, ARES-P II = 300mA). NiCd or Ni-Metal-Hydride cells can be used.

**WHEN USING THE EXTERNAL POWER SUPPLY, CHECK THAT THE CHARGER SWITCH INSIDE THE BATTERY COMPARTMENT IS "OFF" BEFORE INSTALLING DRY CELLS.**

PN 2019 602 150

# CONTENTS

Page

1 DELIVERED WITH: .....	4
1.1 ARES-P II. ....	4
1.2 DELIVERED WITH ARES-P. ....	4
1.3 DELIVERED WITH RCX220. ....	4
2 INSTALLING THE BATTERIES. ....	4
3 INSTALLING THE FLASHCARD. ....	4
4 POWER ON, POWER OFF. ....	4
5 CONTRAST. ....	4
6 BUTTONS. ....	5
7 ARES-P, RCX220, ARES-P II DIFFERENCES. ....	5
8 FIRST TIME SWITCH ON. ....	5
9 MAIN DISPLAY DESCRIPTION. ....	6
Status of the ARES-P. ....	6
10 RECORD (2, 2bis), REWIND (3), STOP (4), PLAY (5), FORWARD (6) KEYS	7
10.1 RECORD KEY (2, 2bis) .....	7
10.2 REWIND KEY (3) AND FORWARD KEY (6) .....	7
10.3 STOP KEY (4) .....	8
10.4 PLAY KEY (5) .....	8
11 LEVEL ADJUSTMENT. ....	8
11.1 OUTPUT LEVEL ADJUSTMENT. ....	8
11.2 INPUT LEVEL ADJUSTMENT. ....	8
11.3 THRESHOLD ADJUSTMENT .....	9
12 CENTER & ARROW KEYS. ....	10
13 LED MODULOMETER. ....	10
14 MAIN MENU. ....	10
14.1 DIRECTORY MENU. ....	10
14.1.1 HORIZONTAL SCROLLING. ....	12
14.1.2 VERTICAL SCROLLING. ....	12
14.1.3 QUIT DIRECTORY. ....	13
14.1.4 TITLING, ARES-P & RCX220 MODE ONLY. ....	13
14.1.5 ERASING TAKE(S), ARES-P & RCX220 ONLY. ....	13
14.1.6 DELETE, ARES-P II ONLY. ....	14
14.1.7 DELETE TO END, ARES-P II ONLY. ....	14
14.1.8 RENUMBER, ARES-P II ONLY. ....	14
14.1.9 RENUMBER ALL, ARES-P II ONLY. ....	14
14.2 LOUDSPEAKER, ARES-P II ONLY. ....	14
14.3 TOOLS. ....	14
14.3.1 DATE AND TIME. ....	14
14.3.2 CARD FORMATTING. ....	15
14.3.3 FORMAT REPAIRING. ....	15
14.3.4 PROGRAM SELECT. ....	15
14.3.5 CONTRAST. ....	15
14.3.6 VERSION. ....	16
14.4 TEMPLATES FOR ARES-P II. ....	16

14.5 SETTINGS MENU .....	17
14.5.1 INPUT FILTER.....	17
14.5.2 ALC.....	17
14.5.3 ALC THRESHOLD.....	17
14.5.4 ALC REACTION SPEED.....	18
14.5.5 BEEP.....	18
14.5.6 COMPRESSION FOR ARES-P/RCX220.....	18
14.5.7 FILE FORMAT FOR ARES-P II.....	18
14.5.8 BACKLIGHT.....	18
14.5.9 OUTPUT MODE.....	19
14.5.10 OUTPUT LEVEL.....	19
14.5.11 SIDE RECORD KEY, ARES-P/RCX220.....	19
14.5.12 SIDE RECORD KEY, ARES-P II MARKERS.....	19
14.6 AUTO RECORD, ARES-P II ONLY.....	19
14.7 MIKE .....	20
14.7.1 48V PHANTOM MIKE POWER.....	20
14.7.2 MIKE TYPE FOR ARES-P II ONLY.....	20
15 LOCKING THE SETTINGS.....	21
16 LOCKING THE KEYPAD, ARES-P II ONLY.....	21
17 AUTO POWER OFF .....	21
18 MESSAGES.....	21
18.1 IN NFS MODE (NAGRA FILE SYSTEM USED BY ARES-P & RCX220 ..	21
18.2 IN FAT MODE .....	22
19 SOFTWARE UPDATE .....	22
20 MENU TREE ARES-P & RCX220.....	23
21 MENU TREE ARES-P II .....	25
22 ARES-P & RCX220 SOFTWARE & INSTALLATION.....	29
22.1 ARES-P SOFTWARE .....	29
22.2 RCX220 SOFTWARE .....	29
23 ARES-P II ON PC OR MAC (FAT 16 MODE) .....	30
24 INPUT CONNECTOR, DIN 12 PIN .....	31
25 LINE OUTPUT CONNECTOR, LEMO 2 PIN .....	31
26 FLASH CARDS COMPATIBILITY, LINEAR AND STRATA.....	32
27 FLASH CARDS COMPATIBILITY, ATA AND COMPACT ATA.....	33
28 SPECIFICATIONS .....	35
29 SAFETY/COMPLIANCE .....	36

## 1 DELIVERED WITH:

### 1.1 ARES-P II.

5 dry cells "AA", 1 DIN connector 12 pin, 1 USB cable, 1 CDR with Ares Import, Digigram Import software and manuals.

### 1.2 DELIVERED WITH ARES-P.

5 dry cells "AA", 1 DIN connector 12 pin, 1 carrying strap, 1 CDR with Ares Import, Digigram Import software and manuals.

### 1.3 DELIVERED WITH RCX220.

5 dry cells "AA", 1 DIN connector 12 pin, 1 carrying strap, 1 USB cable, 1 CDR with Ares Import, Digigram Import software and manuals.

## 2 INSTALLING THE BATTERIES.

To open the machine, push the button on the right side. Inside the battery compartment, push down the black button and remove the inner cover.

Install the 5 "AA" cells observing the polarity and replace the inner cover.

### Important note:

When using the external power supply, check that the switch inside the battery compartment is set to "OFF" before installing dry cells.

Batt. Type	Capacity	Charging time	Record mode	Manufactory
NimH	1300 mAh	05h30	06h00	GP
NimH	2300 mAh	10h00	11h30	Sanyo
Dry cells		x	11h10	Panasonic, Alkaline

In the OFF position, the charger circuitry is not activated and if an external power supply is connected, the machine will run from external supply and not from the batteries.

When an external power supply is connected to the Ares-P II, the green led turns on. During charge, the yellow led turns on. The Ares-P II charges with approx. 300 mA. Charging stops automatically (yellow led turns off). If the yellow led never turns off, it means that one or more cells are defective. If the charger switch is turned on and no batteries are installed while the machine receives external power, the yellow led starts blinking fast.

## 3 INSTALLING THE FLASHCARD.

Open the machine by pressing the button on the side. Insert the flashcard push it fully home (eject button fully out). The software version, for Ares-P or RCX220, 1.20 and higher allows using linear flash cards, ATA cards and compact flash cards. Compact flash cards must be installed using an adapter.

## 4 POWER ON, POWER OFF.

Press the "POWER ON" button (1) for 1 second and the machine switches on. To switch "OFF" the machine push the same button again for 1 second.

**Attention:** the machine cannot be switched OFF during RECORD.

## 5 CONTRAST.

If the display contrast is not set properly at power on, switch off the machine, keep the "RIGHT" arrow key (12) pressed while turning on the machine. This brings the machine directly to the contrast menu. Adjust step-by-step with the "UP" (9) or "DOWN" (11) arrow keys to increase or decrease accordingly. Once the correct contrast is found, press the "CENTER" key (13) to store the new setting in the machine. Press the "LEFT" arrow key (10) to quit the menus. The factory setting has the value "32".

## 6 BUTTONS.

- 1 Power ON / OFF
- 2 + 2 bis Record, Marker key
- 3 Rew ind, skip backwards key
- 4 Stop key
- 5 Play key
- 6 Forward, skip forwards key
- 7 Reduce input sensitivity or playback level key
- 8 Increase input sensitivity or playback level key
- 9 Up arrow key or increase output level key
- 10 Left arrow key
- 11 Down arrow key or reduce output level key
- 12 Right arrow key
- 13 Other menu or execute key



## 7 ARES-P, RCX220, ARES-P II DIFFERENCES.

**ARES-P:** Has no USB connector. The card is formatted "Linear File" non-compatible directly with Windows except if the Ares Import software is used. The recorded files can be G.722 or MPEG 1 layer II. Maximum bitrate is 192kb/s 48kHz stereo (96kb/s per channel).

**RCX220:** Is equipped with an USB 1.1 connector. Windows recognizes the machine as an external sound card. Import of files over USB can only be made via RcxLoad (Digigram software). The card is formatted "Linear File" non-compatible directly with Windows except if the Ares Import software is used. The recorded files can be G.722 or MPEG 1 layer II. Maximum bitrate is 192kb/s 48kHz stereo (96kb/s per channel).

**ARES-P II:** Is equipped with a USB 1.1 connector. In the ARES-P II mode only, the machine is recognized as an external removable hard drive. It also has a built-in speaker, Phantom power and accepts compact micro-drives up to 2 GB.

Without any software options installed, the card is formatted "FAT 16" and is directly compatible with Windows or Mac O/S. The recorded files are Broadcast Wave Format (xxx.wav). Only PCM can be recorded (not compressed).

If equipped with the software option I, the machine emulates also an ARES-P. In the ARES-P II mode, compressed MPEG files can be recorded. In the ARES-P II mode, the maximum bit rate becomes 384kb/s 48kHz stereo.

Only ATA or Compact flash cards can be used in the ARES-P II mode.

If equipped with software option I & II, the machine also emulates an RCX220. This means that in the RCX220 mode, via USB, Windows recognizes the machine as an external soundcard and in the ARES-P II mode as an external removable hard drive.

**Important note:** When making linear recordings (WAV) the range of media that can be used is restricted. The card must be capable of writing data at high speed. A stereo recording at 48kHz requires a data rate of  $2 \times 16 \text{ bits} \times 48000 \text{ sampling frequency} \div 8 \text{ bits per Byte}$  gives a data rate of 192 kBytes per second.

## 8 FIRST TIME SWITCH ON.

This is only important in the case of an ARES-P II. Once the batteries have been installed, the machine will switch on in the ARES-P II mode (FAT 16). The display will show a picture of a cylinder with the word "FAT" for several seconds.

**To change the mode to ARES-P or RCX220 (if minimum the soft 1 package is included) jump to page 15 Paragraph 14.3.4 PROGRAM SELECT before continuing.**

## 9 MAIN DISPLAY DESCRIPTION.

Attention: At power on, the display below is shown, but without the **level bargraph indicator** on the right-hand side. This bargraph appears when the “+” or “-” button (8 or 7) is pressed. It disappears after a few seconds to improve the clarity of the display.

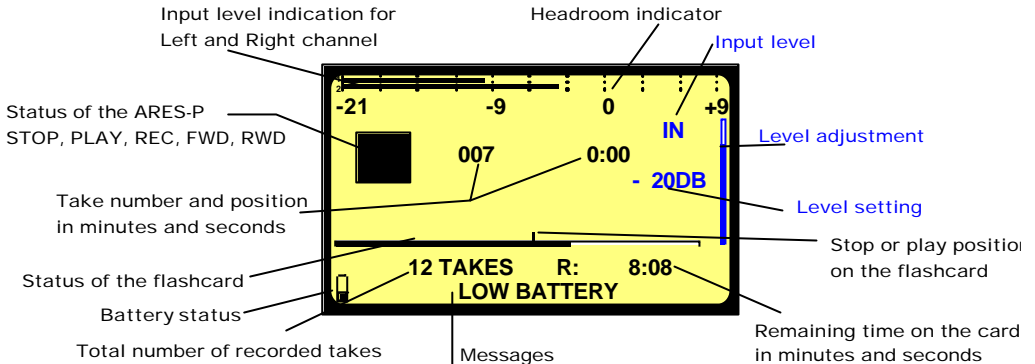

### Status of the ARES-P



“STOP”	ARES-P is in STAND BY mode
“RECORD”	ARES-P is in RECORD mode
“PLAY”	ARES-P is in PLAY mode
“SEARCH FORWARD”	ARES-P is playing fast forwards
“SEARCH BACKWARD”	ARES-P is playing fast backwards

### Take number and position in minutes and seconds

This is the physical playback position. The example shows that playback will start at the beginning of take 7 (0 minutes, 0 seconds).

### Stop or play position on the flashcard

The marker shows the exact playback position, take 7 at 0 minutes, 0 seconds.

### Status of the flashcard

The full length of the bargraph corresponds to the total memory of the inserted flashcard. The black area shows how much memory was already used for recording. The clear area shows the remaining memory.

### Total number of recorded takes

This area shows the total number of takes already recorded on the flashcard.

### Remaining time on the card in minutes and seconds

This indicates how much recording time is left on the card. In this example, it shows 8 minutes, 8 seconds. If the bit-rate is changed, it will automatically be updated. Example 8:08 if 128kb/s was set, it will become 16:16 if the bit-rate was changed to 64kb/s.

### Input level indication for Left and Right channel

In the stereo mode, bargraph 1 corresponds to the left channel and 2 to the right channel. In mono mode, both bargraphs indicate the input level. From 0db, the bargraph shows the headroom up to +9dB. +9dB corresponds to “FF” for the AD converter.

## Messages

This is the area for messages, such as “**LOW BATTERY**”, **CARD FULL**, **NO CARD**, etc. A beep in the headphones corresponds to an arrival of a message on the display.

## Battery status

When the battery icon shows full, it indicates the batteries are fully charged. Full corresponds to a voltage measurement of 6.28V or higher. Each step corresponds to 0.256V. When the voltage drops below 5V, a warning beep is heard in the headphones and the message “**LOW BATTERY**” appears in the display. When the voltage drops below 4.5V the machine automatically switches off. Fully charged Ni Metal Hydride batteries of 1300 mAh capacity will power the recorder for approximately 3 hours and 15 minutes.

## Level Adjustment

This bargraph only appears on the screen during the adjustment of the input sensitivity, the output level or the ALC threshold adjustment. If no adjustment is made it will disappear after a few seconds. Simultaneously, the level setting in dB's as well as the kind of adjustment “**IN**”, “**OUT**” or “**THR**” will appear on the display.

## 10 RECORD (2, 2bis), REWIND (3), STOP (4), PLAY (5), FORWARD (6) KEYS

### 10.1 RECORD KEY (2, 2bis)

#### For ARES-P or RCX220 mode.

A valid formatted card must be fitted and the machine switched ON. To start recording, the “**RECORD**” key (2) or (2bis) can be pressed, even if the machine was in “**PLAY**” mode or is in one of the sub-menus. The “**RECORD**” keys will not work if the machine is deleting a take or formatting the card. If during record the **RECORD** key is pressed again, a new take is automatically created. This function is used for “**MARKING**” the audio during record.

#### For ARES-P II mode.

In addition to the above mentioned functions, the same button can be used for adding markers during record or playback, inside a single file. This depends on the settings made in the “**SIDE KEY**” sub menu.

During record, the front LED as well as the red LED on the keyboard turn ON.

During record, the “**POWER**” key is disabled.

### 10.2 REWIND KEY (3) AND FORWARD KEY (6)

These keys have two functions called “**SKIP**” backwards or forwards and “**REWIND**” or “**FORWARD**”.

#### SKIP.

##### For ARES-P or RCX220 mode.

In “**STOP**” mode: To jump take-by-take, pressing briefly on the “<<” or “>>” keys will decrement or increment the take position.

In “**PLAY**” mode: To jump to other takes on the card, press twice in quick succession the “<<” or “>>” to decrement or increment the take number.

**IMPORTANT:** Only takes with the same compression as the current settings of the machine can be played back using the SKIP buttons. All other takes with a different compression cannot be selected.

##### For ARES-P II mode.

If the recording contains “markers” then these keys will jump to the next (or previous) marker position.

## FORWARD SEARCH & BACKWARD SEARCH.

This function can be executed in “STOP” or “PLAY” mode. Once the “>>” or “<<” key is pressed for more than 0.5 seconds, the machine starts **FORWARD or BACKWARDS SEARCH** at 4 times nominal speed. The longer the button is pressed, the search speed increments up to 128 times nominal speed. When the button is released, the search stops and it returns to its previous function (STOP or PLAY).

### 10.3 STOP KEY (4)

When this key is pressed during record or playback, the machine stops recording or playing and returns to the “EE” mode.

The “EE” mode means that the input signal is fed to the output. This button can also be used as the “PAUSE” key during playback.

### 10.4 PLAY KEY (5)

After a record session pressing the “PLAY” key, immediately plays back the last recorded take. After power on pressing “PLAY” will resume playback from its last position before power down, as long as the batteries are installed.

## 11 LEVEL ADJUSTMENT

### 11.1 OUTPUT LEVEL ADJUSTMENT

During the “STOP” or “RECORD” mode, the output level can be adjusted by the “UP ARROW” key (9) to increase or the “DOWN ARROW” key (11) to decrease. Once one of these keys is pressed, an additional bargraph on the right side of the display appears, indicating “OUT”, showing the current position of the adjustment. “0dB” corresponds to maximum output level, “59dB” corresponds to minimum output level and “OFF” corresponds to mute of the output signal.

The setting of the output level can also be stored in the machine in such a way that every time the machine is switched ON, it will take the same “DEFAULT LEVEL” output adjustment (See “SETTINGS MENU, OUTPUT LEVEL”). During the “PLAY” mode, the output level can be adjusted either by the “UP & DOWN ARROW” keys (9 & 11) or the “+” and “-” keys (8 & 7).

### 11.2 INPUT LEVEL ADJUSTMENT

During “STOP” or “RECORD”, the input level can be adjusted by pressing the “+” (8) or “-” (7) keys to increase or decrease the input sensitivity. Once one of these keys is pressed, an additional bargraph on the right side of the display appears, indicating ‘IN’, corresponding to the current setting. “74dB” corresponds to maximum input gain, “133dB” corresponds to minimum input gain and “OFF” corresponds to muting of the input signal. If the input sensitivity is adjusted for “74dB”, it means that if the input signal at 74dB SPL will be recorded at a 0dB level.

### Level Adjustment in the stereo mode (FAT 16 only)

When in the sub menus the “MIKE” is set to “STEREO”, the left and right channel can be adjusted separately. Holding the left arrow key (10) and adjusting the input sensitivity will only adjust the left channel. Holding the right arrow key (12) and adjusting the input sensitivity will only adjust the right channel. When the input sensitivity between the 2 channels is not identical, the display will automatically show both input sensitivity levels.

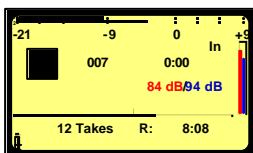



As shown on the picture, the red indications correspond to the left channel, the blue indications correspond to the right channel. If no left or right arrow is pressed during the input sensitivity adjustment, both channels will be adjusted simultaneously and keep the same delta until one of the channels is reaching max. or min. level.

### 11.3 THRESHOLD ADJUSTMENT

The **"THRESHOLD"** adjustment permits selection of the size of the compression zone. It is the lower limit setting of the zone that will be automatically amplified during a silent period. The "ALC" works in a range of 42dB (from 74dB to 116dB). If the **"THRESHOLD"** is set to 104dB, signals of 104dB and higher (max. 116dB) will be recorded at 0dB level (between -2dB and -6dB for a stable signal). A signal of 90dB will be recorded at -14dB (104dB - 90dB). If **"ALC"** (Automatic Level Control) is **"ON"** and the **"ALC THRESHOLD"** is set to **"USING +/- KEYS"** (see SETTINGS MENU, ALC THRESHOLD), the threshold during **"RECORD"** or **"STOP"** can be adjusted by pressing the **"+"** or **"-"** keys (8 or 7). Once one of these keys is pressed, an additional bargraph on the right side of the display, indicating **"THR"** appears, showing the current position of the adjustment. **"74dB"** corresponds to maximum threshold level, **"104dB"** corresponds to minimum threshold level.

## 12 CENTER & ARROW KEYS



By pushing the **"CENTER"** key (13), the machine gives access to the **"DIRECTORY"**, **"TOOLS"** and **"SETTINGS"** sub-menus. Using the **"ARROW"** keys (9 to 12), you navigate between those sub-menus. To move back to the initial display, press the **"LEFT ARROW"** key (10) (except in the **"DIRECTORY"** where **"CENTER"** key (13) needs to be pressed first to return to the sub-menus).

## 13 LED MODULOMETER

The LED modulometer shows the sum of both channels when the machine is set to Stereo operation. The three leds give a quick visual indication in three colors, green, yellow and red. They light at levels of -21, -9 and 0 dB respectively. Normal operation is with the yellow led on and occasionally the red led peaks.

## 14 MAIN MENU.

By pressing the **"CENTER"** key (13), the main menu appears on the display.

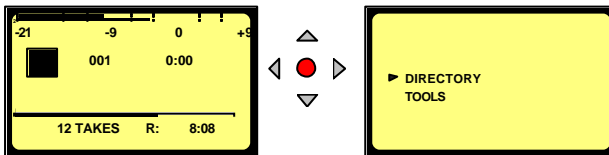

The **"DIRECTORY"** gives access to all the information of the recorded files on the flashcard.

If **"TOOLS"** is selected, other sub menus can be selected: **"DATE & TIME"**, **"CARD FORMATTING"**, **"FORMAT REPAIRING"**, **"PROGRAM SELECT"** and **"VERSION"**.

If **"SETTINGS"** is selected, several other sub-menus can be selected such as: **"OUTPUT LEVEL"**, **"INPUT FILTER"**, **"BEEP"** and **"COMPRESSION"** etc.

Scrolling through the different sub-menus is done by pressing the **"DOWN ARROW"** (11) or **"UP ARROW"** (9) keys.

Escaping from the sub-menu's is done by pushing the **"LEFT" ARROW** key (10).

Entering a sub-menu is done by pushing the **"RIGHT ARROW"** key (12).

Inside a sub-menu, execute the selected setting by pressing the **"CENTER"** key (13).

### 14.1 DIRECTORY MENU.

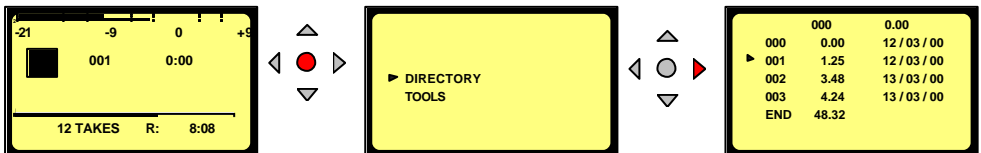

By using the **"UP"**, **"DOWN"**, **"LEFT"**, **"RIGHT ARROW"** keys (9, 11, 10, 12), once **"DIRECTORY"** has been selected, it becomes possible to scroll vertically and horizontally to view all the recorded files and their specifications.

If the marker has a "↴" shape, it means that the take compression is the same as the current settings of the machine.

If the marker has a ">" shape, it means that the take compression is different from the current settings of the machine.

In the latter case, if the **PLAY** button (5) is pressed, the corresponding compression will be automatically loaded in the DSP, and play starts.

If the marker is in front of one of the audio takes, the **PLAY**, **STOP**, **FWD** and **RWD** function keys (3,4,5 &6) become active.

If the **RECORD** button (2 or 2bis) is pressed, the display returns to the main screen and the recording starts.

### 14.1.1 HORIZONTAL SCROLLING.

Use the "LEFT" (10) and "RIGHT" (12) "ARROW" keys.

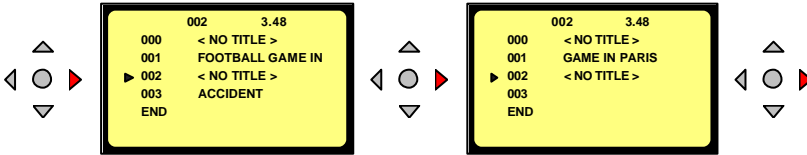
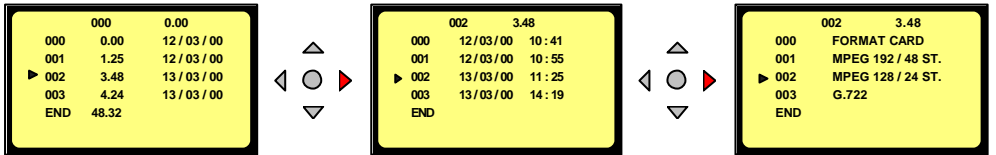
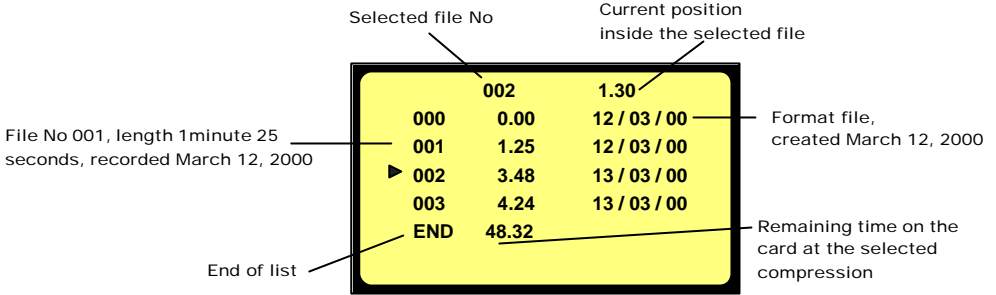

The display shows the length, the date of recording, the time at the record start, the type of compression and the title of each take. The title can be maximum 31 characters long and scrolls over the display in 3 stages.

### 14.1.2 VERTICAL SCROLLING.

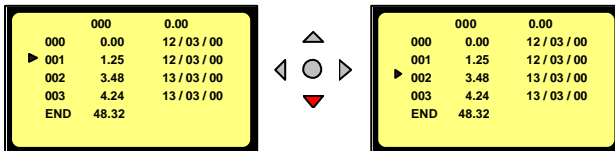

Pushing the "UP" (9) or "DOWN" (11) "ARROW" keys makes the vertical scrolling. The take number 000 is the format take. It shows the time and date when the card was last formatted.

### 14.1.3 QUIT DIRECTORY.

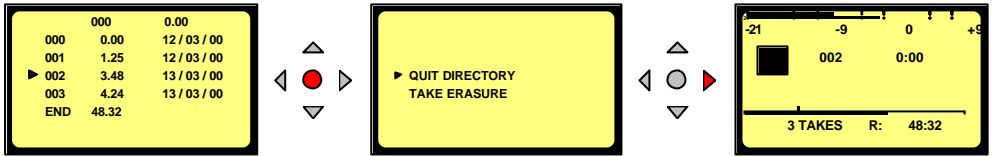

To escape from the “**DIRECTORY**”, press the “**CENTER**” button (13) once followed by the “**RIGHT**” arrow key (12). The display returns to “**STATUS**” display.

### 14.1.4 TITLING, ARES-P & RCX220 MODE ONLY.

Titles can be added to the format file (000) and each sound file for identification purposes.

In the “**DIRECTORY**”, select the take for a new title.

Press the “**CENTER**” key once and the following display appears:



Pressing the “**STOP**” key returns the display to the “**DIRECTORY**”.

Characters can be selected with the “**UP**” and “**DOWN**” keys. To enter the selected character, press the “**CENTER**” key.

To delete a character, highlight the corresponding character with the **LEFT ARROW** or **RIGHT ARROW** keys and press the “**PLAY**” key.

To insert a character, highlight the corresponding character for the insertion area and press the “**>>**” key. All characters from the highlight position will be shifted one space.

To record the title on the flashcard, press the “**RECORD**” key once.

### ATTENTION:

Once a title is added to a recording, it cannot be altered in any way on a linear flash card. Titles on ATA cards can be modified. If during titling, the “**RECORD**” key is pressed twice, the title will be recorded and the machine starts a new audio record.

If during “**TITLING**” the “**RECORD**” button on the side of the machine is pressed, audio record starts immediately and the title is not recorded.

### 14.1.5 ERASING TAKE(S), ARES-P & RCX220 ONLY.

**Example: take 2 and higher take numbers**

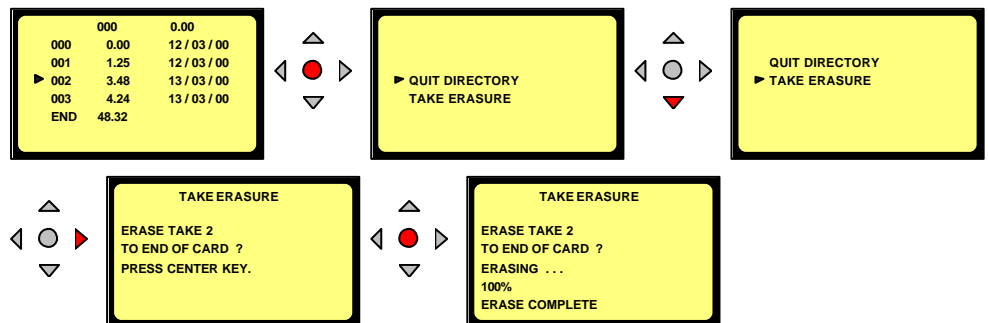

To delete one or more takes, select in the directory the lowest take number that needs to be deleted, press the **"CENTER"** button (13) and select the **"TAKE ERASURE"** menu. Once the selection confirmed by pressing the **"CENTER"** button (13), the erasing starts.  
To escape from the sub-menu, press the **"LEFT"** (10) or **"RIGHT"** (12) key once.

**NOTE:** Erasing individual takes in the middle of the **"DIRECTORY"** is not possible. The erase feature will always erase from the selected take to the end of the card.

#### 14.1.6 DELETE, ARES-P II ONLY.

Any take from the directory can be deleted without influencing other takes.

#### 14.1.7 DELETE TO END, ARES-P II ONLY.

Erase the selected take and all takes after until the end of the card.

#### 14.1.8 RENUMBER, ARES-P II ONLY.

Permits after deleting file(s) to renumber the files from the selected file until the end of the card.

#### 14.1.9 RENUMBER ALL, ARES-P II ONLY.

Permits after deleting file(s) to renumber all the files from file 1 until the end of the card.

#### 14.2 LOUDSPEAKER, ARES-P II ONLY.

This switches "ON" or "OFF" the internal loudspeaker.

**NOTE:** The internal loudspeaker can only be used in the playback mode.

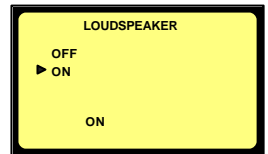

#### 14.3 TOOLS.

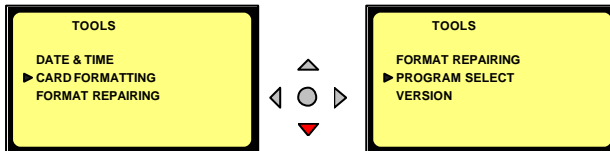

several sub-menus are available.

#### 14.3.1 DATE AND TIME.

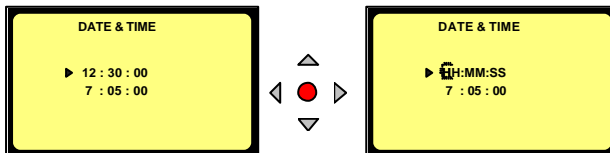

Selecting **"DATE & TIME"** gives access to change the time and date of the real time clock. Once the **"CENTER"** button (13) is pressed, the first digit starts blinking. The number can be modified by pushing the **"UP"** or **"DOWN"** (9 or 11) keys. Pressing the **"RIGHT"** arrow key (12) jumps to the next digit. Once the last number is introduced, the clock starts running. (Hours, Hours, Minutes, Minutes, Seconds, Seconds)

Introducing the date uses the same procedure.

Once the last number is introduced, the date is memorized.

To escape from the sub-menu, press the **"LEFT"** (10) or **"RIGHT"** (12) key once.

### 14.3.2 CARD FORMATTING.

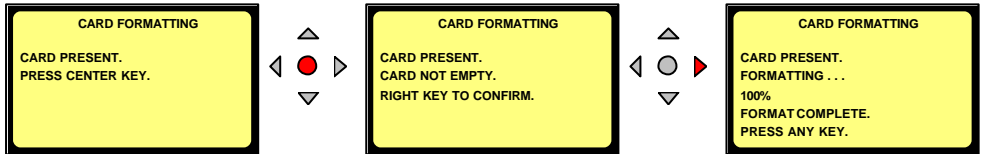

Execute by pressing the “**RIGHT**” arrow key (12) and the card formatting will begin.

Once the formatting is finished, the display returns to the previous menu.

To escape from the sub-menu, press the “**LEFT**” (10) or “**RIGHT**” (12) key once.

When the format command is executed, “**CARD NOT EMPTY**” appears if one or more takes are on the card (including format take 000).

### 14.3.3 FORMAT REPAIRING.

If during record, the card was removed (or batteries removed), an “**UNCLOSED FILE**” will be left on the card. This utility allows the user to close this file correctly.

“**FORMAT CORRUPTED**” will be shown.

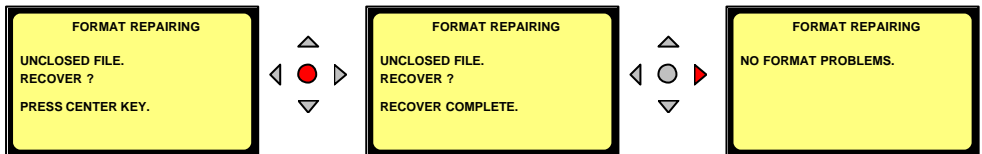

Follow the instructions on the display to recover the take. The last recorded file will be closed at the end of the memory of the card. The remaining time becomes 0 min. 0 sec.

To escape from the sub-menu, press the “**LEFT**” (10) or “**RIGHT**” (12) key once.

### 14.3.4 PROGRAM SELECT.

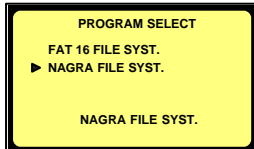

The program select permits to swap between the 2 recording modes “FAT 16” mode (ARES-P II) or “NAGRA” mode (ARES-P or RCX220) compressed files.

To escape from the sub-menu, press the “**LEFT**” key (10) once.

### 14.3.5 CONTRAST.

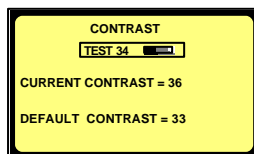

This menu permits to adjust the contrast of the display. Pressing the “**UP**” (9) or “**DOWN**” (11) key changes the current contrast. Pressing the “**CENTER**” key (13) stores the contrast settings as a default value at power on.

To escape from the sub-menu, press the “**LEFT**” key (10) once.

### 14.3.6 VERSION.

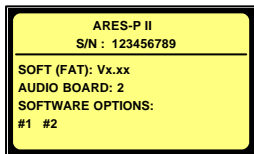

Selecting the **VERSION** sub-menu shows the serial number of the recorder as well as current version of the software installed. The version shown in this picture corresponds to the version for the **FAT** mode. Turning on the machine in the **NFS** mode will show the **NFS** version.

To escape from the sub-menu, press the **LEFT** key (10) once.

### 14.4 TEMPLATES FOR ARES-P II.



Only the Ares-P II can store and recall 4 different templates.

To have an overview of the different sub-menu settings that can be stored, refer to the menu tree at the end of this manual. Only menu settings with a red square against it can be stored.



To use a template, setup the machine as required, then go to **TEMPLATES**, select **STORE 1** and press the execute key (13). The message **DONE** will appear. If now any changes were made in the setup, you can go to **RECALL 1** and press the execute key once again. This returns the machine to the settings stored in template 1.



## 14.5 SETTINGS MENU.

The settings menu gives access to several sub-menus.

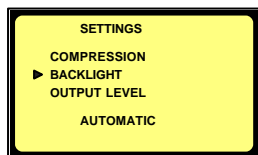
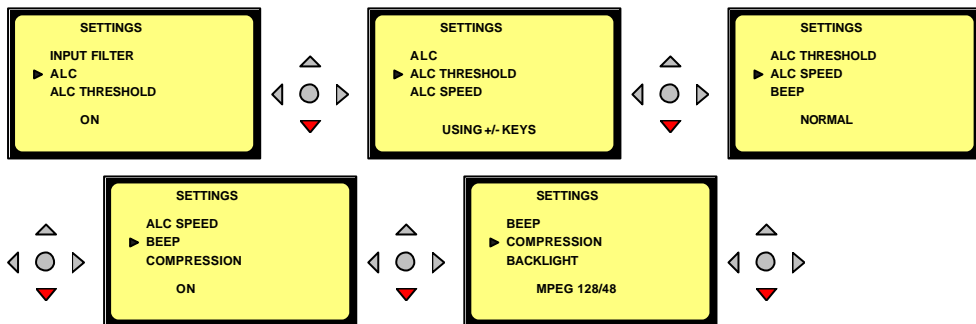

The current setting of each is always shown at the bottom of the display.

### 14.5.1 INPUT FILTER.

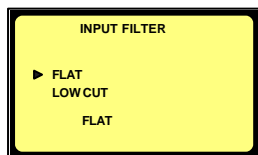

Two possibilities are available: "FLAT" or "LOW CUT".

### 14.5.2 ALC.

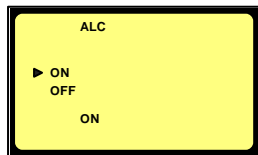

From this sub-menu, the "ALC" can be switched "ON" or "OFF". It is highly recommended to switch on the "LOW CUT" filter if "ALC" is turned ON.

### 14.5.3 ALC THRESHOLD.

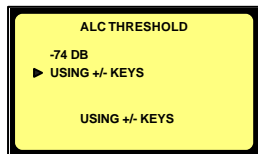

The "THRESHOLD" can be adjusted from  $-104$  dB to  $-74$  dB. In this case the "+"key (8) and the "-"key (7) are disabled. If "USING +/- KEYS" is selected, the "+"key (8) and "-"key (7) are enabled during "STOP" and "RECORD" mode, which allows the "THRESHOLD" level to be adjusted without returning in the "SETTINGS" menu.

#### 14.5.4 ALC REACTION SPEED.

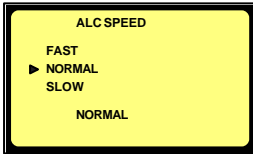

The “**ALC SPEED**” can be set to a “**FAST**”, “**NORMAL**” or “**SLOW**” reaction time.

#### 14.5.5 BEEP.

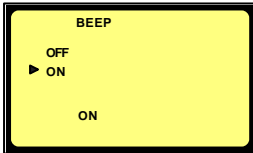

The beep signal is only available at the output and is not recorded. It can be switched “**ON**” or “**OFF**”.

#### 14.5.6 COMPRESSION FOR ARES-P/RCX220.

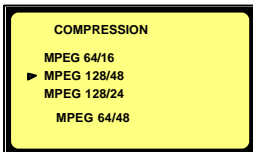

17 different types of compression can be selected. Use the “**UP**” (9) or “**DOWN**” (11) arrow keys to select the type of compression to be used and press the “**CENTER**” key (13) to select one. The display returns to the previous menu.

**Example:** MPEG 64/48 stands for: MPEG 1Layer II MONO compression at a total bit-rate of 64kb/s using a sampling frequency of 48kHz.  
MPEG 192/48 ST stands for: MPEG 1 Layer II STEREO compression at a total bit-rate of 192kb/s (96kb/s per channel) using a sample rate of 48kHz.

#### 14.5.7 FILE FORMAT FOR ARES-P II.

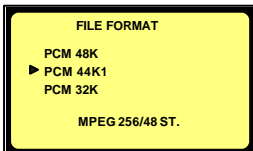

The Ares -P II without any soft option can only record in a linear mode (not compressed). If the soft option I is installed it includes also the selection of MPEG compression (as for the Ares -P/RCX220) and this time up to 384kb/s.

#### 14.5.8 BACKLIGHT.

The backlight can be set to always “**OFF**”, always “**ON**” or “**AUTOMATIC**”.

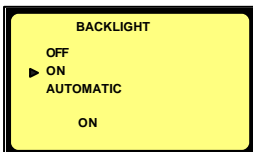

In the “**AUTOMATIC**” mode, the backlight turns on for 15 seconds, each time a key is pressed.

### 14.5.9 OUTPUT MODE.

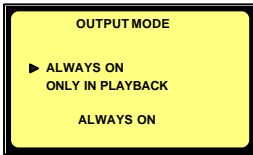

This sub-menu permits to turn on or off the sound to the output connector in the case that a little speaker is used instead of a headphone. **"ALWAYS"** means that the output sound is always present. **"ONLY IN PLAYBACK"** means that the output sound is present only during playback but not present in the record mode or EE mode.

### 14.5.10 OUTPUT LEVEL.

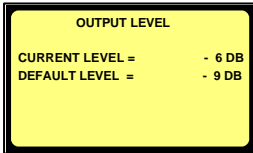

The **"CURRENT LEVEL"** corresponds to the setting before entering the sub-menu. To modify this level, press the **"UP"** or **"DOWN"** keys (9 or 11).

The **"DEFAULT LEVEL"** is the level that has been saved in the memory. To modify the **"DEFAULT LEVEL"** to the value of the **"CURRENT LEVEL"**, press the **"CENTER"** Key (13). The default value will be remembered even if the unit loses power.

### 14.5.11 SIDE RECORD KEY, ARES-P/RCX220.



This sub-menu permits to select different modes for the red record side button. When selecting **"RECORD/NEW TAKE"**, the action on the side button stays identical as for the keyboard record key. When selecting **"RECORD/STOP"**, every time the red button is pressed once, the Ares-P/RCX220 toggles between record and stop mode.



If **"START/STOP"** is selected, the record starts when the red button is pressed and stops when the button is released.

This mode is also handy if



a microphone with a start/stop button is used. Simultaneously in this mode, during record, the keyboard record and stop key are disabled.

### 14.5.12 SIDE RECORD KEY, ARES-P II MARKERS.



This sub-menu also has the possibility to set markers inside a file during record or playback. If **"RECORD/MARK"** is selected, the first time the button is pressed will put the Ares-P II in record. At each successive press of the button, a marker will be recorded.

If **"MARK (REC/PLAY)"** is selected, markers only can be added during record or playback. If **"UNASSIGNED"** is selected, the function is not used.

The Ares -P II also has the other possibilities as described in the previous paragraph (14.5.13).

### 14.6 AUTO RECORD, ARES-P II ONLY.

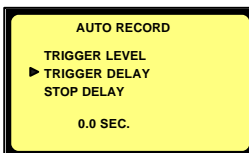
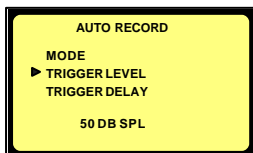

The **"AUTO RECORD"** menu permits to turn on or off the auto record mode. This mode of recording permits to start a recording automatically depending on the settings of the different parameters described below. Once the parameters set, put the machine in the record mode. The recording will start once the requested level and length of any incoming sound is obtained.

The “**TRIGGER LEVEL**” sub-menu permits to adjust the level detection to start the recording and can be set in steps of 10 dB from 50 dB SPL to 120 dB SPL.

The “ **TRIGGER DELAY**” menu permits to adjust the continuous duration or length of the sound level before the recording starts. It can be set from 0.0 seconds to 1 second. Example: if you clap your hands a single time and the start delay is set to 0.1 second, the recording will not start, as the handclap was shorter than 0.1 seconds.

The “**STOP DELAY**” permits to adjust the duration of recording once the sound level drops below the threshold level and can be set from 5 seconds up to 15 minutes or nonstop. Once the delay is passed, the machine will return to the waiting position ready for the next recording

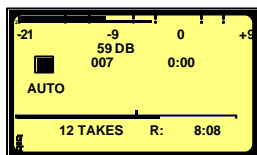

The left picture shows the machine ready to record automatically. The right picture shows the machine in the record mode. The Ares-P II can also be stopped by pressing the Stop button (4)

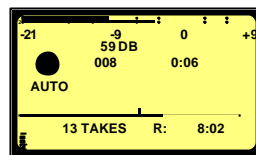

## 14.7 MIKE

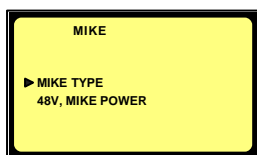

This menu gives access to the selection of the microphone type (Mono or Stereo) as well as the 48V power supply.

### 14.7.1 48V PHANTOM MIKE POWER.

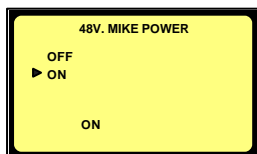

If Phantom microphones are used the 48V must be turned on.

**Attention: Before connecting any NAGRA plug-in condenser microphone to the Ares-P II, verify first that the 48V is turned off.**

### 14.7.2 MIKE TYPE FOR ARES-P II ONLY.

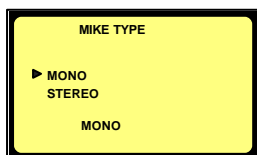

If “**MONO**” is selected and a stereo pair of microphones is connected and the “**FILE FORMAT**” is set to a mono recording, both channels will be mixed and reduced by 3 dB before they are recorded as a mono channel.

If “**STEREO**” is selected and a mono microphone is connected and the “**FILE FORMAT**” is set to a stereo recording, only the left channel will be recorded.

If “**MONO**” is selected and a mono microphone is connected and the “**FILE FORMAT**” is set to a stereo recording, both channels will have the same signal.

## 15 LOCKING THE SETTINGS.

By pressing a certain combination of keys when turning on the machine, the settings can then be locked step-by-step. This to prevent, the user changing the settings inadvertently or otherwise. To obtain the combination code, contact your local **NAGRA** dealer.

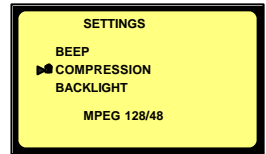

Any sub-menu can be locked by pressing the **"STOP"** button or unlocked by pressing the **"PLAY"** button. When the sub-menu has been locked, a closed padlock appears in front of the selected sub-menu. When the sub-menu has been unlocked, the closed padlock disappears. To remove the password, switch off and on again the machine.

## 16 LOCKING THE KEYPAD, ARES-P II ONLY.

During record or playback the keyboard can be locked by pressing the left and right arrow keys (10 & 12) during a few seconds (this until **'KEYPAD LOCKED'** appears on the screen). To unlock the keyboard, press the left and right arrow keys (10 & 12) until the message disappears.

## 17 AUTO POWER OFF

When the machine is left in the **"STOP"** mode for 10 minutes, it will automatically switch off. During the last 14 seconds of that period, the beep sounds every second. When any key is pressed, the power counter will be reset.

To disable the auto power off, **from the power off status**, press and hold the center key while pressing the power key.

In the case that the machine is turned on with the auto power disabled, the message **"NO AUTO POWER OFF"** appears during a few seconds.

## 18 MESSAGES

### 18.1 IN NFS MODE (NAGRA FILE SYSTEM USED BY ARES-P & RCX220)

"LOW BATTERY"	The battery voltage has dropped too low
"NO CARD"	No card is inserted
"FORMAT CORRUPTED"	Occurs if the card was removed during record or power lost abruptly
"CARD FULL"	No more record memory is available
"INVALID CARD"	The card is not recognized by the machine
"UNFORMATTED CARD"	The card is recognized but not formatted
"CARD WRITE PROTECTED"	Write protection switch on the card is ON
"OPEN WRITE ERROR"	Defective card or card error
"WRITE ERROR"	Defective card or card error
"CARD NEARLY FULL"	60 seconds recording time left on the card
"ERASE COMPLETED"	At the end of erasure of one or several takes
"FORMAT COMPLETED"	At the end of a card formatting
"CARD READ ERROR"	Impossible to read the directory due to a defective card or a read error
"READ ERROR"	Read error during playback
"UNKNOWN FORMAT"	The card is recognized but not the type of format
"CARD TOO SLOW"	Depending from the selected file format, some cards do not accept a high recording bit rate
"BUFFER OVERFLOW"	Record buffer is full due to a slow card
"AUTO POWER OFF"	The machine will switch of in the next 15 seconds
"NO AUTO POWER OFF"	Auto power off has been disabled

## 18.2 IN FAT MODE

"WRONG USB VERSION"	DSP and USB software versions are incompatible
"CARD FULL"	No more memory available on the card
"OPEN WRITE ERROR"	Defective card or card error
"WRITE ERROR"	Defective card or card error
"READ ERROR"	Defective card or card error
"CARD TOO SLOW"	Depending from the selected file format, some cards do not accept a high recording bit rate
"DIRECTORY FULL"	999 takes (files) already recorded
"CARD NEARLY FULL"	60 seconds recording time left on the card
"KEYPAD LOCKED"	The full keypad is locked
"AUTO POWER OFF"	The machine will switch of in the next 15 seconds
"LOW BATTERY"	The battery voltage has dropped too low
"NO AUTO POWER OFF"	Auto power off has been disabled
"INVALID CARD"	The card is not recognized by the machine
"NO CARD"	No card inserted in the slot
"UNKNOWN FORMAT"	The card is recognized but not the type of format
"DIR UNUSABLE"	The "ARESP" folder cannot be created Example: an ARESP file name was already present
"CARD READING..."	Appears during the directory reading
"CARD BUSY..."	Appears when the card is busy Example: delete to end or renumbering
"USB MODE"	The card is accessed via USB
"AUTO REC. LEVEL ERROR"	The input gain level is not suitable to the record trigger level

## 19 SOFTWARE UPDATE

When opening the machine, a small black 6 pin connector becomes visible located just under the flashcard. This connector is a RS232 connector. A special adapter "**NP-PCA**" is needed to connect the RS232 from the machine to a PC or laptop.

When new software from NAGRA becomes available, it can be delivered by Email or it can be downloaded from the NAGRA web site. Thanks to a software called "**PuserLoader**" the machine can be updated with the new software version. This takes about 2 to 3 minutes.

# 20 MENU TREE ARES-P & RCX220

TREE CONFIGURATION IN THE CASE OF ARES P OR RCX220 (NAGRA FILE SYST.)

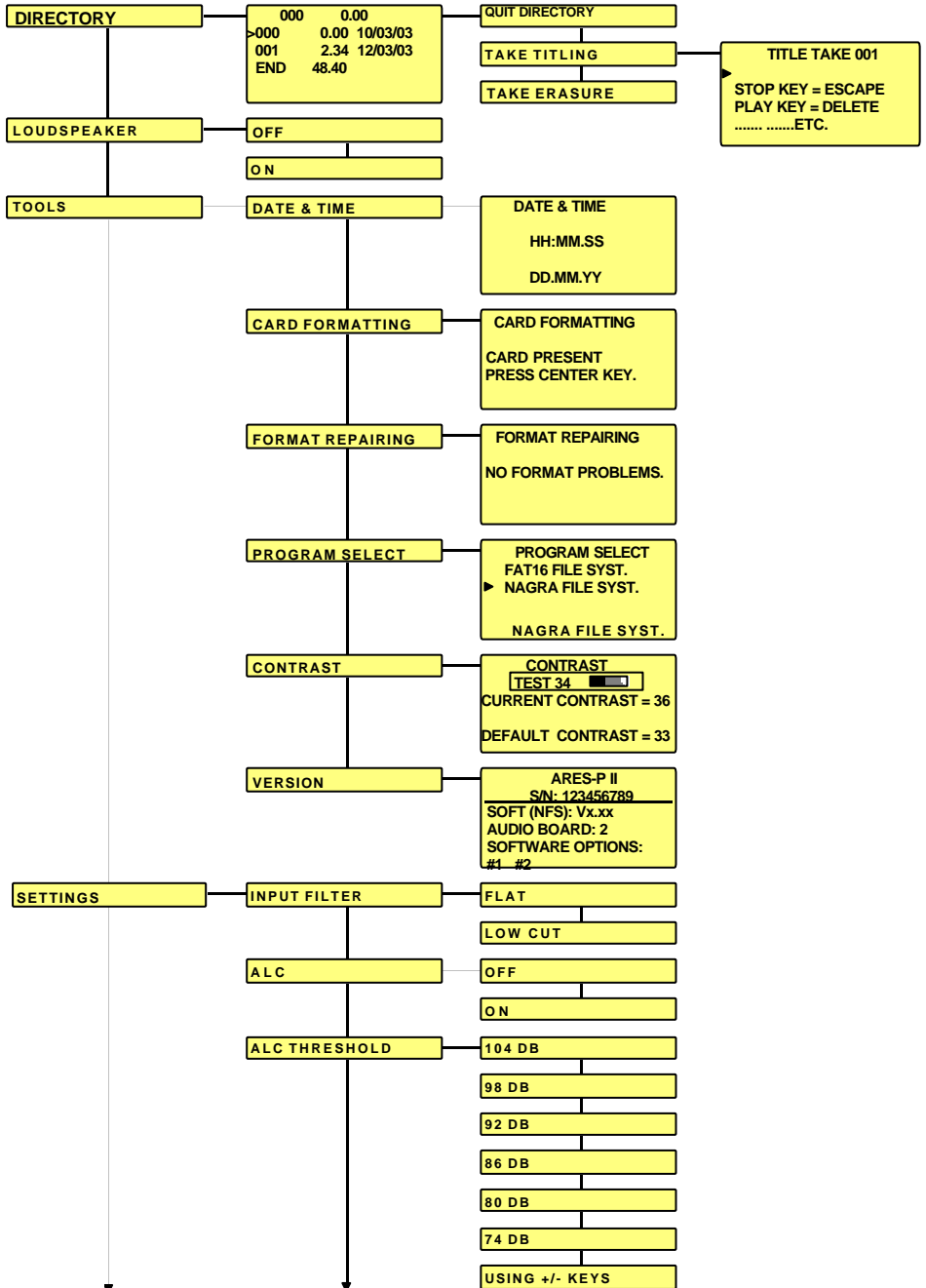

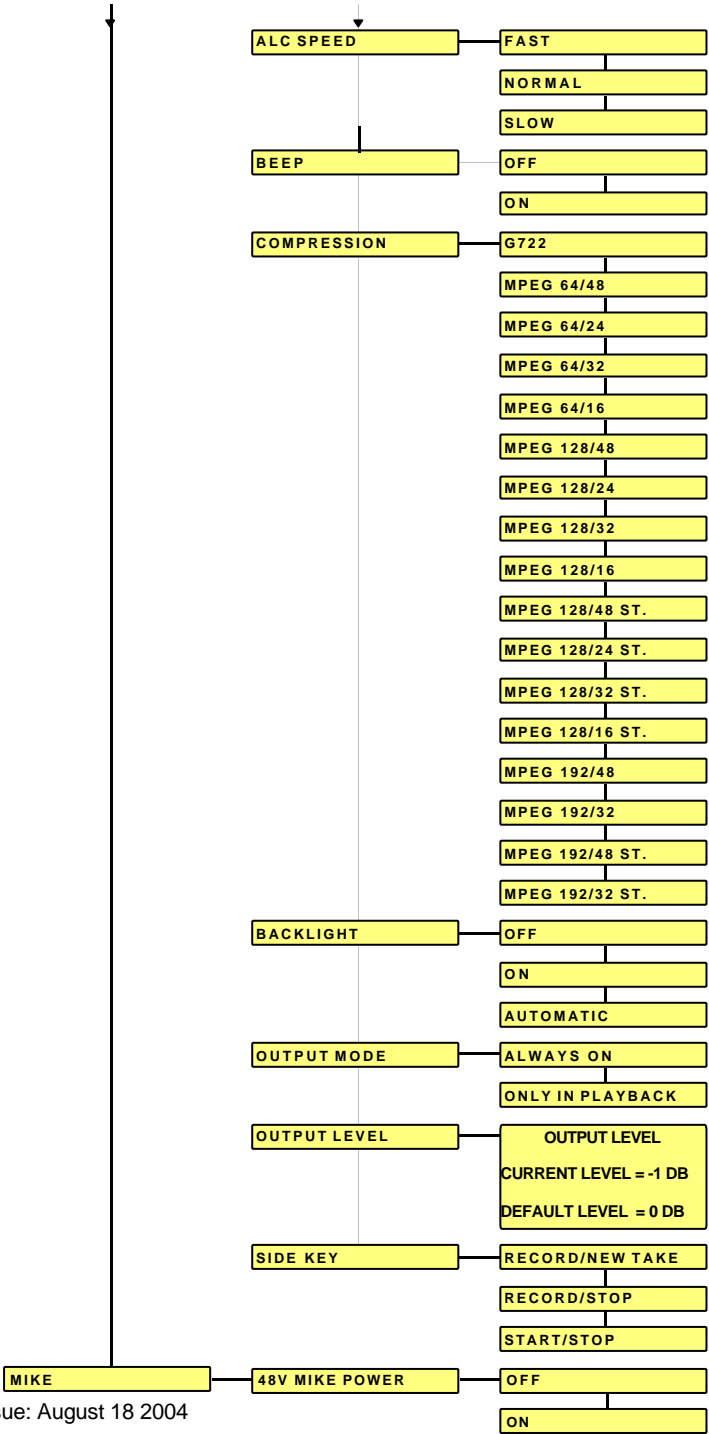



# 21 MENU TREE ARES-P II

TREE CONFIGURATION IN THE CASE OF ARES PII (FAT) INCLUDING SOFT OPTION I

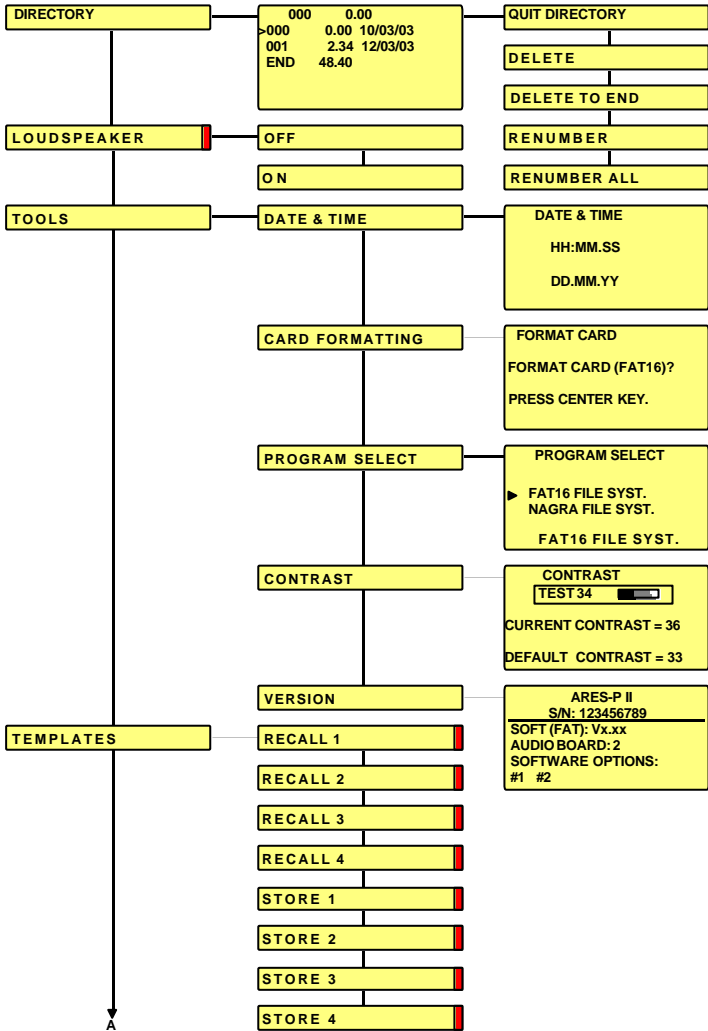

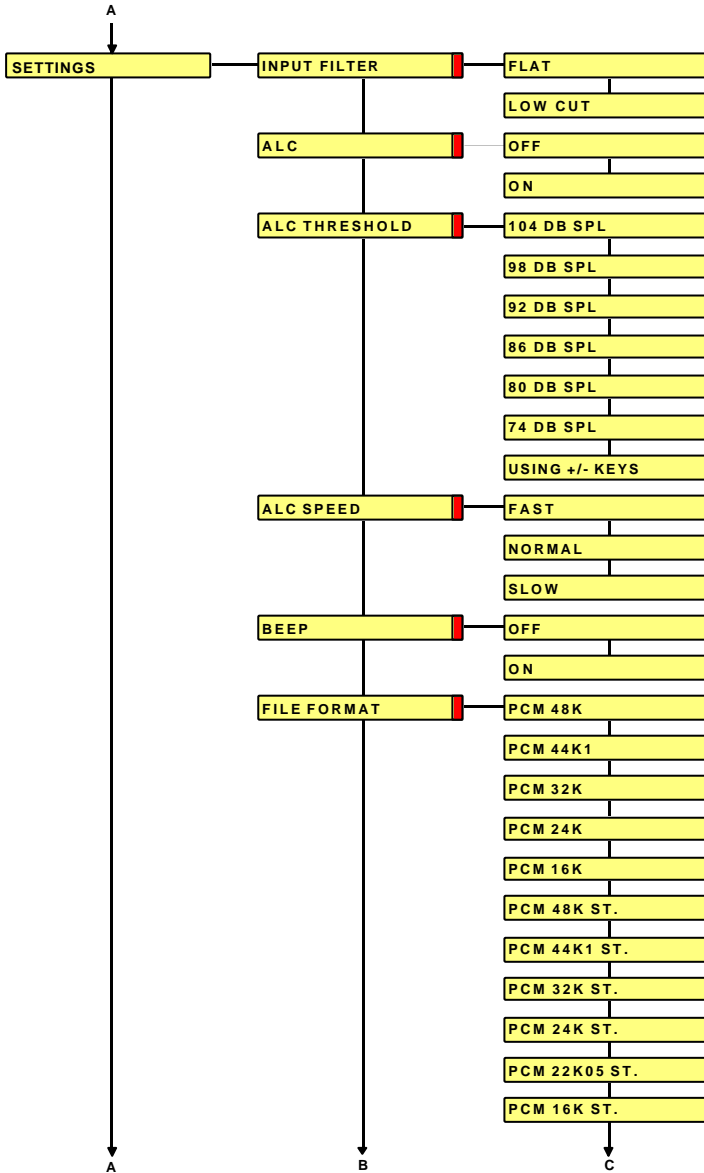

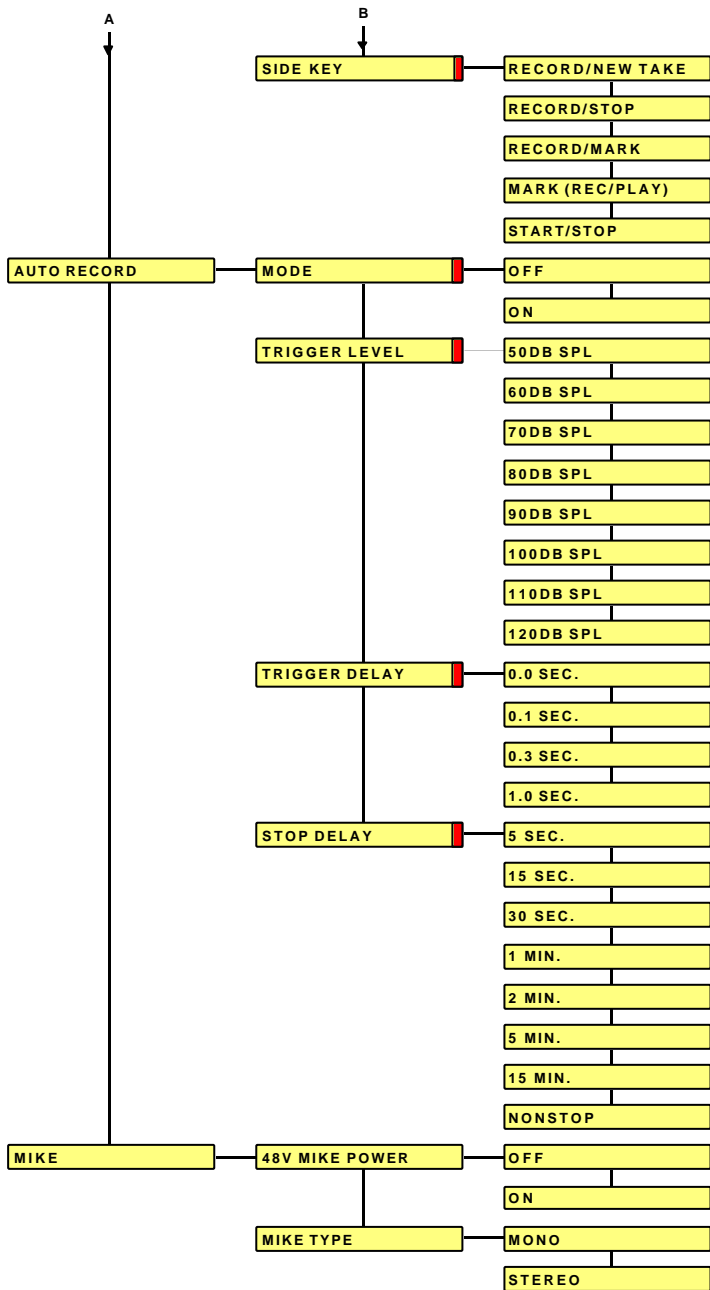

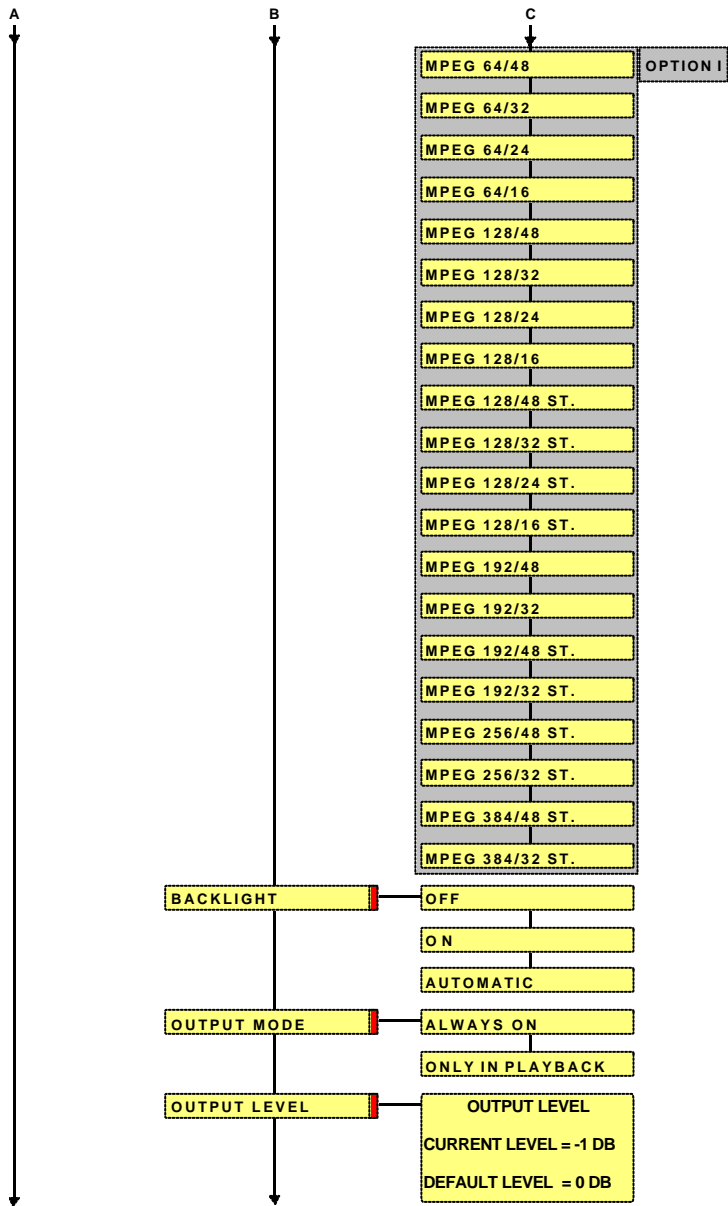

## 22 ARES-P & RCX220 SOFTWARE & INSTALLATION

These programs add several features when the RCX220 is connected to the USB port of a PC or if the flashcard from the ARES-P is inserted in a PC PCMCIA slot:

Display the directory of the flash card

Playback of the recorded files

Import recorded files into the computer's hard disk

Edit the recorded files.

Insert the CD in your PC or laptop and follow the instructions.



Name	Size	Type	Modified
DigigramVersionAugust2002		File Folder	09.09.2002 06:20
NetiaVersionDecember2001		File Folder	09.09.2002 06:20
pocket2.ico	1 KB	ACDSee ICO Image	04.09.2002 10:24
AUTORUN.INF	1 KB	Setup Information	04.09.2002 10:25
Select.txt	4 KB	Text Document	09.09.2002 06:06

### 22.1 ARES-P SOFTWARE

Carefully read the text file in the root directory before any installation.

From explorer, double click the NetiaVersion folder followed by the AresImport folder.



Name	Size	Type	Modified
AresImport		File Folder	09.09.2002 06:20
Elan drivers		File Folder	09.09.2002 06:20
DebugEnglish.txt	7 KB	Text Document	13.12.2001 16:09
DebugFrench.txt	7 KB	Text Document	13.12.2001 16:09
Readme1.txt	2 KB	Text Document	12.12.2001 11:15

Double click "SETUP.EXE" file to start the installation.

If the PCMCIA slot is based on an ISA or PCI bus or built-in to a laptop, the Elan drivers need also to be installed. If the PCMCIA slot is connected via SCSI, the Elan drivers may not be installed.

### 22.2 RCX220 SOFTWARE

Carefully read the text file in the root directory before any installation.

From explorer, double click the DigigramVersion folder followed by setup.exe.

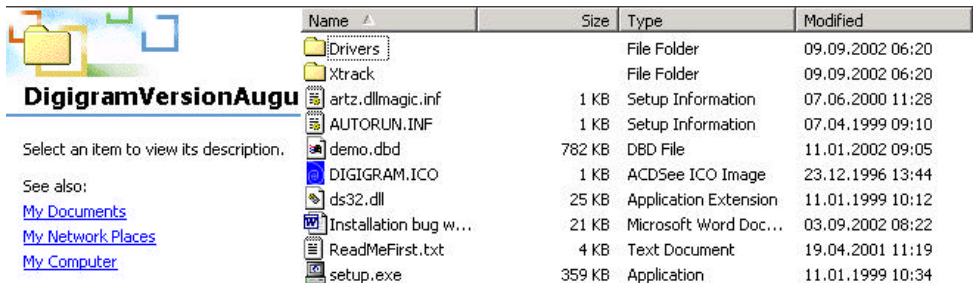

Name	Size	Type	Modified
Drivers		File Folder	09.09.2002 06:20
Xtrack		File Folder	09.09.2002 06:20
artz.dllmagic.inf	1 KB	Setup Information	07.06.2000 11:28
AUTORUN.INF	1 KB	Setup Information	07.04.1999 09:10
demo.dbd	782 KB	DBD File	11.01.2002 09:05
DIGIGRAM.ICO	1 KB	ACDSee ICO Image	23.12.1996 13:44
ds32.dll	25 KB	Application Extension	11.01.1999 10:12
Installation bug w...	21 KB	Microsoft Word Doc...	03.09.2002 08:22
ReadMeFirst.txt	4 KB	Text Document	19.04.2001 11:19
setup.exe	359 KB	Application	11.01.1999 10:34

### AresImport:

AresImport permits to read the directory from the flash card as well as playback and or import and conversion.

### RCXLoad :

Display the files located on the memory card with their characteristics (date, duration, encoding format) in an MS explorer fashion.

Playing back a selected file, using RCX220 audio output.

Using Drag and Drop, import one or several files with format conversion to MPEG Layer 2 or PCM format.

### XtrackLE (a Limited Edition of Xtrack):

Uses the physical I/O of the RCX220 as well as any other standard device.

Offers two fully independent mono or stereo tracks where records can be uploaded via RCXload.

Provides you with of a complete set of tools to cut, copy, paste, trim any portion of a track, as well as level editing functions such as fade in and fade out.

Once the edit finished, it can be processed into a single sound file (**MPEG** or **PCM**) with automatic sampling frequency and bit rate conversion.

To obtain full multi-track editing capabilities including mp3 export, the full version of Xtrack software can be purchased from Digigram.

## 23 ARES-P II ON PC OR MAC (FAT 16 MODE)

Turn on the Ares-P II and connect it via the USB cable to the PC or Mac. After a moment, the new device will be detected as an external removable hard drive.

**IMPORTANT: for Windows 98 SE users; connect the Ares-P II (FAT mode) to the PC. Once Windows asks for the USB drivers to be installed, specify the way to the CDR "Win98SeUsbDrivers" folder.**

The following pictures are an example on PC were the Ares - P II is recognized as disk (F).

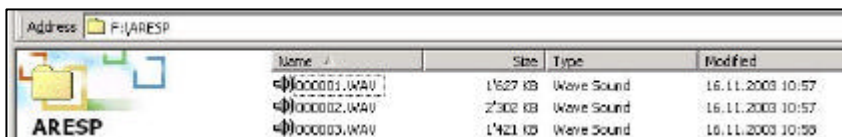

On PC, to remove the Ares-P II from the USB connection, double click first the "Unplug or Eject Hardware" icon and stop the corresponding drive letter before removing the USB cable.



## 24 INPUT CONNECTOR, DIN 12 PIN

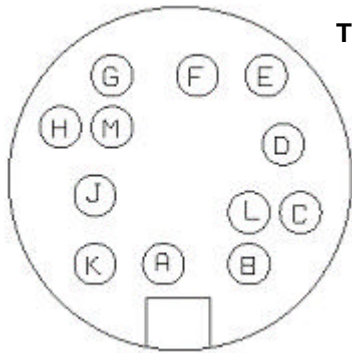

TOP VIEW

A	MIKE (R) Hi
B	GROUND
C	MIKE (L) S2
D	MIKE (L) S1
E	MIKE (L) Lo
F	MIKE (L) Hi
G	+50V (Ares-P/RCX220), 48V (Ares-P II)
H	MIKE (R) S2
J	MIKE (R) S1
K	MIKE (R) Lo
L	+5V
M	S-REC

### Inputs:

Pin "A" and "K" corresponds to the right Hi and Lo microphone input.

Pin "F" and "E" corresponds to the left Hi and Lo microphone input.

### Sensitivity:

When "H" and "J" are shorted, max. gain is obtained for the right microphone input (0.2mV/hPa).

When "H" and "J" stays open, min. gain is obtained for the right microphone input (4mV/hPa).

Pin "H" and "J" corresponds to the sensitivity inputs for the right microphone.

Pin "C" and "D" corresponds to the sensitivity inputs for the left microphone.

### Attention:

If the machine is in the mono mode, only the left input is used, the right input is muted.

The 50V available on the connector is **NOT** for powering Phantom powered microphones, but to power electrostatic microphones. The Ares-P II does not provide 50V. But a 48V Phantom supply on the input connections. This can be switched "ON" and "OFF" within the menu settings of the machine.

### S-REC:

When in the 2<sup>nd</sup> RECORD KEY menu START/STOP is selected. Shorting this pin to ground will put the machine into the "RECORD" mode. Opening this connection to ground puts the machine to "STOP" mode. This can be used for a remote RECORD/STOP control.

## 25 LINE OUTPUT CONNECTOR, LEMO 2 PIN

The line output connector (Lemo connector 2 pin) is situated next to the microphone input connector. The output level for +9dB on the modulometer is 1.55V<sub>rms</sub>.

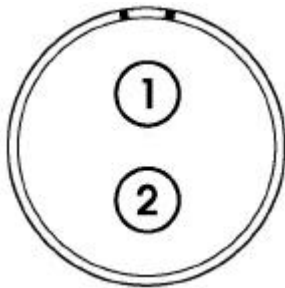

Pin 1	LEFT CHANNEL
Pin 2	RIGHT CHANNEL

## 26 FLASH CARDS COMPATIBILITY, LINEAR AND STRATA.

TYPE		CAP.	MANUF.	TEC.	IDENTIFICA.	ARES-C	ARES-P	ARES	ARES	ARES	RCX
							RCX220	95	NT	IMPORT	LOAD
CMCIA	1	20	INTEL	Linear	IMC020FLSA-15	Yes	Yes	Yes	Yes	Yes	Yes
CMCIA	2	20	EDI	Linear	FLA2800C15	Yes	Yes	Yes	Yes	Yes	Yes
CMCIA	3	10	INTEL	Linear	IMC010FLSA-15	Yes	Yes	Yes	Yes	Yes	Yes
CMCIA	4	20	EDI	Linear	FLA3200C15	Yes	Yes	Yes	Yes	Yes	Yes
CMCIA	5	20	EDI	Linear	FLA2400C15	Yes	Yes	Yes	Yes	Yes	Yes
CMCIA	6	40	EDI	Linear	FLA3200C15	Yes	Yes	Yes	Yes	Yes	Yes
CMCIA	7	64	EDI	Strata	FLF1200C25	Yes	Yes	Yes	Yes	Yes	Yes
CMCIA	8	64	EDI	Strata	FLF1203C25	Yes	Yes	Yes	Yes	Yes	Yes
CMCIA	9	128	EDI	Strata	FLF1203C25	Yes	Yes	No	No	No	Yes
CMCIA	10	80	EDI	Strata	FLF0203C25	Yes	Yes	No	No	No	Yes
CMCIA	11	192	EDI	Strata	FLF1203C25	Yes	Yes	No	No	No	Yes
CMCIA	12	48	EDI	Strata	FLF0203C25	Yes	Yes	Yes	Yes	Yes	Yes
CMCIA	13	64	EDI	Strata	FLF0203C25	Yes	Yes	Yes	Yes	Yes	Yes
CMCIA	14	128	PRETEC	ATA	AFH128	Yes	Yes	No	No	Yes	Yes
CMCIA	15	64	PRETEC	ATA	AFH064	Yes	Yes	No	No	Yes	Yes
CMCIA	16	64	SANDISK	ATA	AB0120JR-USA	Yes	Yes	No	No	Yes	Yes
CMCIA	17	48	SANDISK	ATA	V0004GW-USA	Yes	Yes	No	No	Yes	Yes
CMCIA	18	64	EDI	ATA	ATA2500C25	Yes	Yes	No	No	Yes	Yes
CMCIA	19	96	EDI	ATA	ATA2500C25	Yes	Yes	No	No	Yes	Yes



## 27 FLASH CARDS COMPATIBILITY, ATA AND COMPACT ATA.

All ATA type & compact ATA type cards with this background color are accepted and sold by Nagra

AresImport test was done using an external PCMCIA SCSI adapter on NT-4

All cards went into the record mode for at least 1 minute at 192kb/s 48kHz stereo at ambient temperature

Nagra does not warranty the correct functionality of the machine if other cards than the yellow ATA cards are used

TYPE		CAP.	MANUF.	TEC.	IDENTIFICA.	ARES-C	ARES-P	ARES	ARES	ARES	RCX
							RCX220	95	NT	IMPORT	LOAD
PCMCIA	14	128	PRETEC	ATA	AFH128	Yes	Yes	No	No	Yes	Yes
PCMCIA	15	64	PRETEC	ATA	AFH064	Yes	Yes	No	No	Yes	Yes
PCMCIA	16	64	SANDISK	ATA	AB0120JR-USA	Yes	Yes	No	No	Yes	Yes
PCMCIA	17	48	SANDISK	ATA	V0004GW-USA	Yes	Yes	No	No	Yes	Yes
PCMCIA	18	64	EDI	ATA	ATA2500C25	Yes	Yes	No	No	Yes	Yes
PCMCIA	19	96	EDI	ATA	ATA2500C25	Yes	Yes	No	No	Yes	Yes
PCMCIA	20	128	EDI	ATA	ATA2500C25	Yes	Yes	No	No	Yes	Yes
PCMCIA	21	256	PRETEC	ATA	AFH256	Yes	Yes	No	No	Yes	Yes
PCMCIA	22	128	FEIYA	ATA	TS128MFLASHB	No	No	No	No	No	No
PCMCIA	23	48	PRETEC	ATA	AFH048	Yes	Yes	No	No	Yes	Yes
PCMCIA	24	96	PRETEC	ATA	AFH096	Yes	Yes	No	No	Yes	Yes
PCMCIA	25	80	CENTENIAL	Strata	ES00080	No	No	No	No	No	No

TYPE		CAP.	MANUF.	TEC..	IDENTIFICA.	ARES-C	ARES-P	ARES	ARES	ARES	RCX
							RCX220	95	NT	IMPORT	LOAD
COMPACT	C1	64	EMTEC	ATA	347629AI	No	No	No	No	No	No
COMPACT	C2	64	RIDATA	ATA	RITEK 06415006D	No	Yes	No	No	Yes	Yes
COMPACT	C3	128	ACE	ATA	FFC128	Yes	Yes	No	No	Yes	Yes
COMPACT	C4	64	SANDISK	ATA	AB0105LEI	Yes	Yes	No	No	Yes	Yes
COMPACT	C5	128	NAGRA(ACE)	ATA	FFC128	Yes	Yes	No	No	Yes	Yes
COMPACT	C6	64	ACE	ATA	FFC064	Yes	Yes	No	No	Yes	Yes
COMPACT	C7	64	NAGRA(ACE)	ATA	FFC064	Yes	Yes	No	No	Yes	Yes
COMPACT	C8	48	PRETEC	ATA	ACT048	Yes	Yes	No	No	Yes	Yes
COMPACT	C9	64	PRETEC	ATA	ACT064	Yes	Yes	No	No	Yes	Yes
COMPACT	C10	128	PRETEC	ATA	ACH128	Yes	Yes	No	No	Yes	Yes
COMPACT	C11	32	ACE	ATA	FFC032	Yes	Yes	No	No	Yes	Yes
COMPACT	C12	32	DATAFAB	ATA	922022134	Yes	Yes	No	No	Yes	Yes
COMPACT	C13	128	MEMORY CARD	ATA	TS128MFLASHCP	Yes	Yes	No	No	Yes	Yes
COMPACT	C14	48	SANDISK	ATA	V0006GP-CHINA	Yes	Yes	No	No	Yes	Yes
COMPACT	C15	256	PRETEC	ATA	ACH256	Yes	Yes	No	No	Yes	Yes
COMPACT	C16	96	PRETEC	ATA	ACH096	Yes	Yes	No	No	Yes	Yes

## 28 SPECIFICATIONS

### GENERAL

<u>Data Storage medium</u>	<u>PCMCIA ATAc ards, Compact flash cards</u>
<u>Recording Method</u>	<u>Digital (PCM) or Digital compression</u>
<u>Compression type</u>	<u>ISO MPEG Layer II</u>
<u>A/D &amp; D/A conversion</u>	<u>20 Bit Sigma-Delta</u>
<u>Sampling Rate</u>	<u>16, 22.05, 24, 32, 44.1, 48 kHz</u>
<u>Bit-Rates</u>	<u>64, 128, 192, 256, 384 kb/s*</u>
<u>Mono/Stereo</u>	<u>Switchable and input routing</u>
<u>Recording Capacity</u>	<u>21 minutes on a 256 MB card Stereo 48 kHz,</u> <u>PCM</u>
<u>Max. RecordingCapacity</u>	<u>132* minutes on a 256 MB card Stereo 48</u> <u>kHz, 256 kb/s</u>
<u>PCMCIA Slot</u>	<u>Single type I &amp; II</u>
<u>Dynamic Range Adjust</u>	<u>40 dB for 0 dB record (manual), 40 dB for 0</u> <u>dB record (ALC)</u>
<u>Filters</u>	<u>"Flat", "LFA"</u>
<u>File Format</u>	<u>Broadcast Wave Format (.wav)</u>

### INPUTS

<u>Mic. Inputs</u>	<u>12 pole DIN connector</u>
<u>Microphone Powering</u>	<u>48 V Phantom*</u>
<u>Sensitivity</u>	<u>From 2 mV to 10 mV for 0 dB recording</u>
<u>Line Input</u>	<u>Symmetrical transformerless</u>
<u>Line Input Sensitivity</u>	<u>0.44 V to 1.4 V for 0 dB recording</u>

### OUTPUTS

<u>Headphone</u>	<u>Jack 3.5 mm stereo connector</u>
<u>Line Output</u>	<u>Lemo connector</u>
<u>THD at 1 kHz</u>	<u>0.1 %</u>
<u>Frequency response</u>	<u>30 Hz – 20 kHz (-3 dB in EE mode)</u>
<u>Total dynamic range</u>	<u>80 dB</u>

### POWER SUPPLY

<u>Internal batteries</u>	<u>5 x "AA" cells</u>
<u>Consumption</u>	<u>7.5 V - 180 mA, 6 V – 220 mA during record</u> <u>(no display light)</u>

### PHYSICAL

<u>Dimensions</u>	<u>188 x 80 x 28 mm (7½ x 3¼ x 1 inch)</u>
<u>Weight</u>	<u>450 g. (1 lb)</u>

(\* Including the MPEG option)

**Note:** We have not tested all available cards and adapters on the market. Therefore we cannot guaranty the perfect operation in our machines. Cards and adapters supplied by Nagra are guaranteed to operate within the machine specifications .

# DECLARATION DE CONFORMITE *DECLARATION OF CONFORMITY*

**FABRICANT:** NAGRAVISION SA, 1033 CHESEAX SUISSE  
**MANUFACTURER:** NAGRAVISION SA, 1033 CHESEAX, SWITZERLAND

**APPAREIL :** ARES-P/RCX220/ARES-P II  
**MODEL:** ARES-P/RCX220/ARES-P II

Par la présente nous déclarons l'équipement conforme à toutes les exigences fixées dans les normes:

*We hereby declare that the equipment conforms to the all the requirements outlined by the following norms:*

**NORMES GENERIQUES APPLICABLES :**  
**APPLICABLE GENERIC NORMS:**

CENELEC EN 61000-3-2  
61000-3-3  
50081-1  
50082-1

**Avertissement.**

Bien qu'étant conforme aux normes, cet appareil peut, dans des cas exceptionnels, provoquer des interférences. Dans ce cas, il peut être demandé à l'utilisateur de prendre des mesures appropriées.

**Warning.**

*Although this equipment conforms to the stated norms, under certain exceptional circumstances it may provoke interference. In this event the user may be asked to take appropriate measures.*

Other electrical regulatory certification pending.

Cheseaux 1<sup>er</sup> trimestre 2003  
Cheseaux 1<sup>st</sup> quarter 2003

**NAGRAVISION SA KUDELSKI GROUP**  
**Route de Genève 22**  
**CH-1033 Cheseaux**  
**Switzerland**

**Phone +41 (0)21 732-0101**  
**Fax +41 (0)21 732-0100**  
**E-mail [info@nagra.com](mailto:info@nagra.com)**

All rights reserved-© August 18 2004

## Free Manuals Download Website

<http://myh66.com>

<http://usermanuals.us>

<http://www.somanuals.com>

<http://www.4manuals.cc>

<http://www.manual-lib.com>

<http://www.404manual.com>

<http://www.luxmanual.com>

<http://aubethermostatmanual.com>

Golf course search by state

<http://golfingnear.com>

Email search by domain

<http://emailbydomain.com>

Auto manuals search

<http://auto.somanuals.com>

TV manuals search

<http://tv.somanuals.com>