

MLZA6DT

Motorized Zoom Lens Control

Installation/Operation Manual

C518M Rev B (4/91)

Pelco • 3500 Pelco Way • Clovis, CA 93612-5699 • USA • www.pelco.com
(800) 289-9100 or (1-559) 292-1981 • FAX (800) 289-9150 or (1-559) 292-3827
International customers call (1-559) 292-1981 or FAX (1-559) 348-1120

TABLE OF CONTENTS

Section	Page
1.0 WARNINGS	1
2.0 SCOPE	2
3.0 DESCRIPTION	2
3.1 OPTIONS	2
4.0 INSTALLATION	3
4.1 CONNECTOR ASSEMBLY	3
4.2 R300 RACK MOUNT KIT INSTALLATION	5
5.0 OPERATION AND SYSTEM TEST	6
5.1 SYSTEM TEST FOR MLZA6DT	6
6.0 MAINTENANCE	7
7.0 SCHEMATIC	8
8.0 SPECIFICATIONS	9

LIST OF ILLUSTRATIONS

Figure	Page
1 Connector Assembly	3
2 Wiring Diagram for Output Pin Assignments	4
3 R300 Rack Mount Kit Installation	5
4 Basic System Configuration	6
5 MLZA6DT Schematic	8
6 MLZA6DT Dimension Drawing	9

**INSTALLATION/OPERATION MANUAL
MODEL MLZA6DT
MOTORIZED ZOOM LENS CONTROL**

1.0 WARNINGS

Prior to installation and use of this product, the following WARNINGS should be observed.

1. Installation and servicing should only be done by Qualified Service Personnel and conform to all Local codes.
2. Unless the unit is specifically marked as a NEMA Type 3, 3R, 35, 4, 4X, 6 or 6P enclosure, it is designed for Indoor use only and it must not be installed where exposed to rain and moisture.
3. The product may bear the following marks:
 4. Only use replacement parts recommended by Pelco.
 5. After replacement/repair of this unit's electrical components, conduct a resistance measurement between line and exposed parts to verify the exposed parts have not been connected to line circuitry.

This symbol indicates that dangerous voltage constituting a risk of electric shock is present within this unit.



CAUTION:
TO REDUCE THE RISK OF ELECTRICAL SHOCK, DO NOT REMOVE COVER. NO USER-SERVICEABLE PARTS INSIDE. REFER SERVICING TO QUALIFIED SERVICE PERSONNEL.

This symbol indicates that there are important operating and maintenance instructions in the literature accompanying this unit.



CAUTION:
RISK OF ELECTRIC SHOCK.
DO NOT OPEN.

Please thoroughly familiarize yourself with the information in this manual prior to installation and operation.

2.0 SCOPE

The information contained within this manual covers the MLZA6DT Motorized Zoom Lens Control.

3.0 DESCRIPTION

The MLZA6DT is a desktop zoom lens control with auto/manual iris control designed for use with all Pelco motorized zoom lenses with “ND” or “MS” in the model number. The servo amplifier contained within the control detects the slightest change in video level and drives the iris motor to open or close the iris to maintain proper faceplate illumination.

Front panel switches provide control of automatic/manual iris operation, zoom and focus functions, with optional manual control of the iris. Speed and video level are adjustable through the front panel knob controls.

3.1 OPTIONS

R300	Rack mount kit for up to three (3) control modules
------	--

4.0 INSTALLATION

4.1 CONNECTOR ASSEMBLY

Installation and/or testing will require you to assemble the connector parts provided. Fabricate the interconnecting cable according to the following steps (reference Figure 1).

1. Slide part A of the cable clamp (item 1) over the end of the cable (item 1, part C) with the threaded end of the cable clamp facing the connector (item 5).
2. If the cable has a diameter less than 1/2 inch (1.3 cm), slide the rubber boot (item 2) over the end of the cable and pull through the cable clamp to so that the boot encases the cable and forms a good seal.
3. Strip back the cable jacket approximately 1-1/4 inches (3.2 cm) and separate the individual conductors (item 3).

4. The contact pins supplied with the mating connector are the "crimp" type which may also be soldered if you so desired (item 4).
5. After crimping or soldering the contact pins to the conductors, push them into the proper holes in the connector until they snap in place.

NOTE: Contacts cannot be removed from the connector without the use of the appropriate AMP extraction tool which is available from Pelco.

6. Slide part A of the cable clamp toward the connector and screw the parts together. Attach part B (item 1) onto part A and connect both parts with the screws provided.
7. Connect the cable assembly to the unit and seat the connector by twisting the locking collar until it snaps into position.

Refer to Figure 2 for wiring diagram.

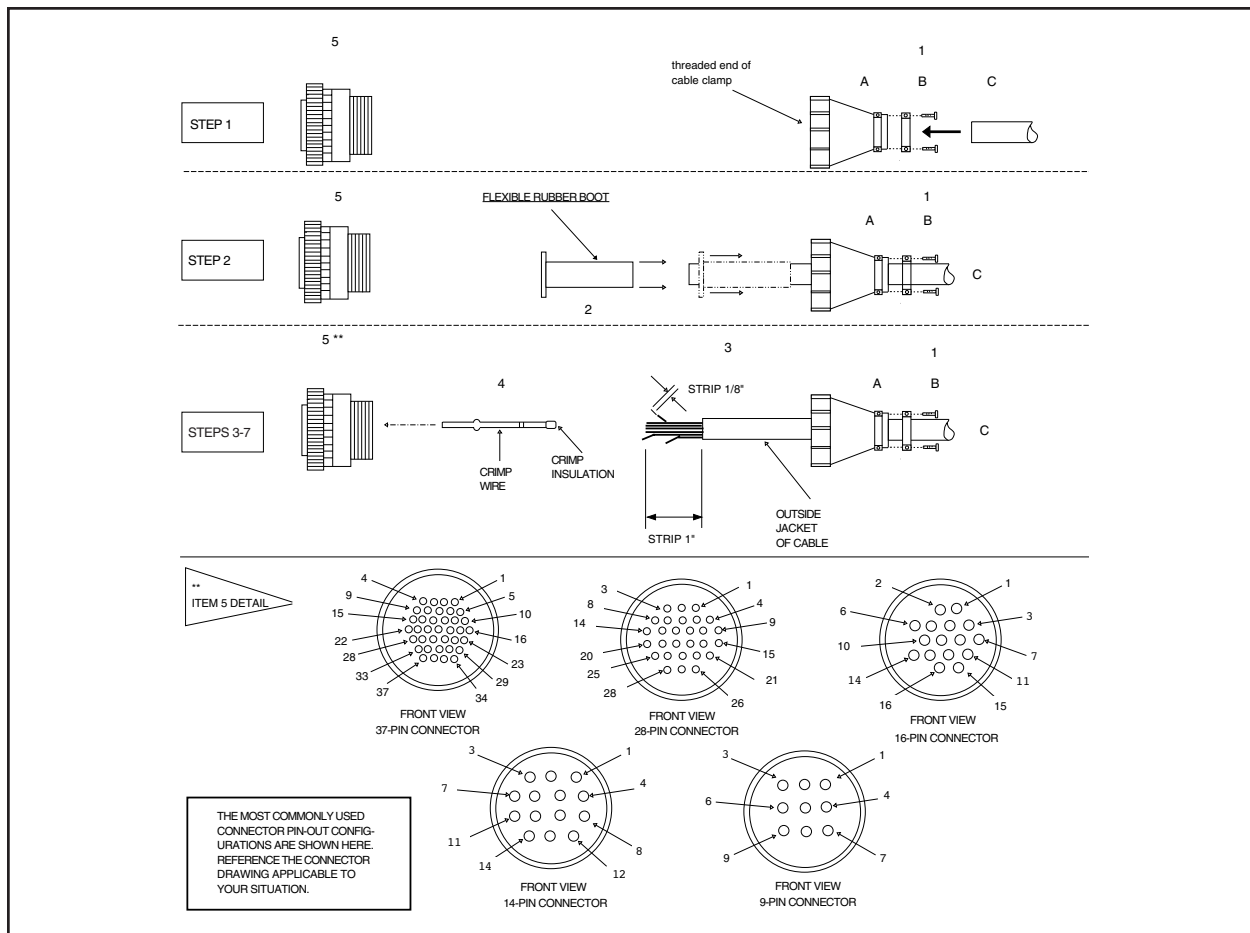
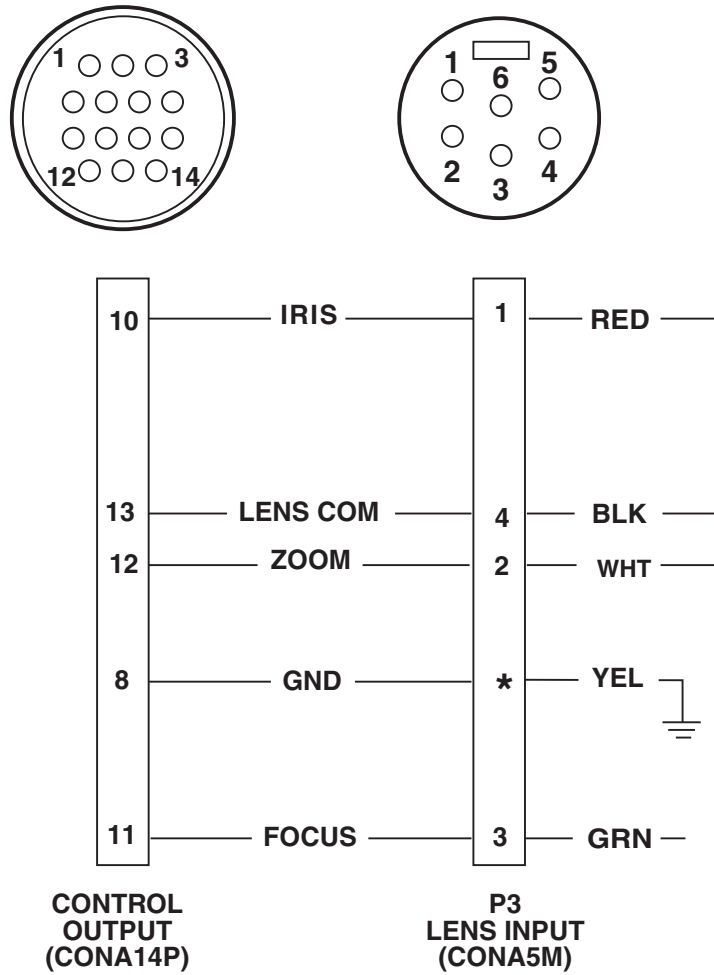

Figure 1. Connector Assembly



***GROUND WIRE IS SOLDERED TO CONNECTOR HOUSING.**

Figure 2. Wiring Diagram for Output Pin Assignments

4.2 R300 RACK MOUNT KIT INSTALLATION

The R300 Rack Mount Kit holds up to three control modules. Blank filler panels are provided for less than three modules.

To convert desk top units, perform the following steps (refer to Figure 3):

1. Disconnect the equipment from its power supply.
2. Remove the feet from the bottom of the unit.
3. Remove the four (4) screws retaining the cover and remove the cover from the equipment.
4. Loosen the eight (8) screws retaining the front and rear faceplates.
5. Insert the chassis into the rack body; sandwich the rack body slotted tabs between the chassis and the front plate, and the chassis and the rear plate.
6. Repeat steps 1-5 for other units or assembly of the blank faceplate supplied.
7. Install the two straps sandwiching the slotted tabs as in Step 4, keeping the bent ends outside the body.
8. Attach the straps and rack body to the chassis with two (2) cover screws, when applicable. If no chassis is placed in either side port of the rack, a screw and nut must be used to attach the strap and body together.
9. Align the front and faceplates with each other and tighten the four (4) screws for each plate.
10. Repeat step eight (8) for the rear plates.
11. Reconnect the unit to its power supply.

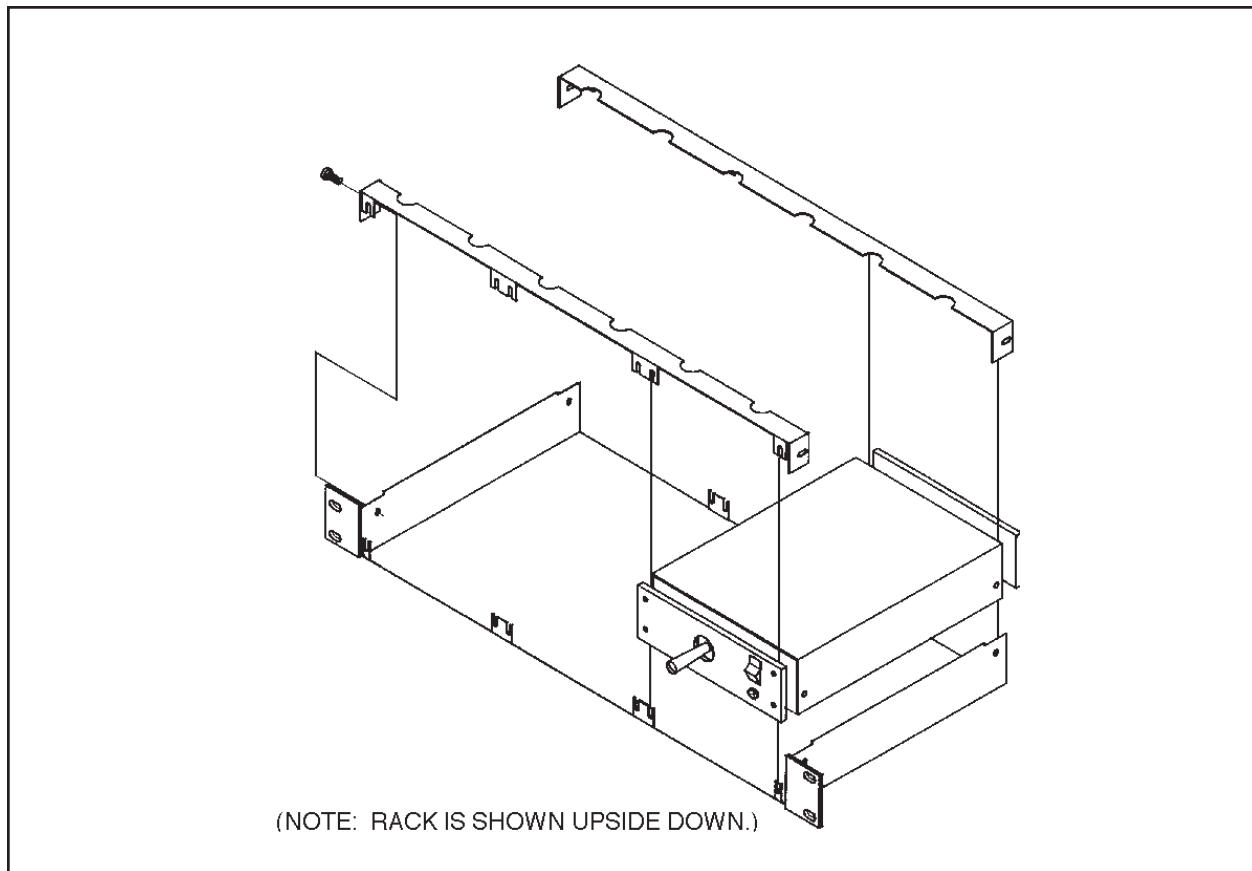

Figure 3. R300 Rack Mount Kit Installation

5.0 OPERATION AND SYSTEM TEST

5.1 SYSTEM TEST FOR MLZA6DT

1. Hook up the cable between the output connector on the MLZA6DT and the input connector on the lens (see Figure 4).
2. Connect the video cable from the camera to the VIDEO LOOP-THRU on the rear panel and to the monitor (see Figure 4).
3. Turn the power switch on the MLZA6DT to the OFF position, and plug the power cord into a 120 VAC power source.
4. For MANUAL operation, put the power switch in the MAN position. Observing the monitor, test for proper operation of zoom, focus, and iris functions with related switches on the front panel.
5. For Auto operation, put the power switch in the AUTO/ON position. The IRIS switch should not operate; ZOOM and FOCUS switches should operate normally. Next, adjust the level of video using the LEVEL knob on the front panel and observing the monitor. As the video level is adjusted, the iris should open or close depending on whether video display is bright or dark.
6. Test the control for fast and slow speeds of all functions by turning the LENS SPEED knob on the front panel and observing their operation as the knob is adjusted.

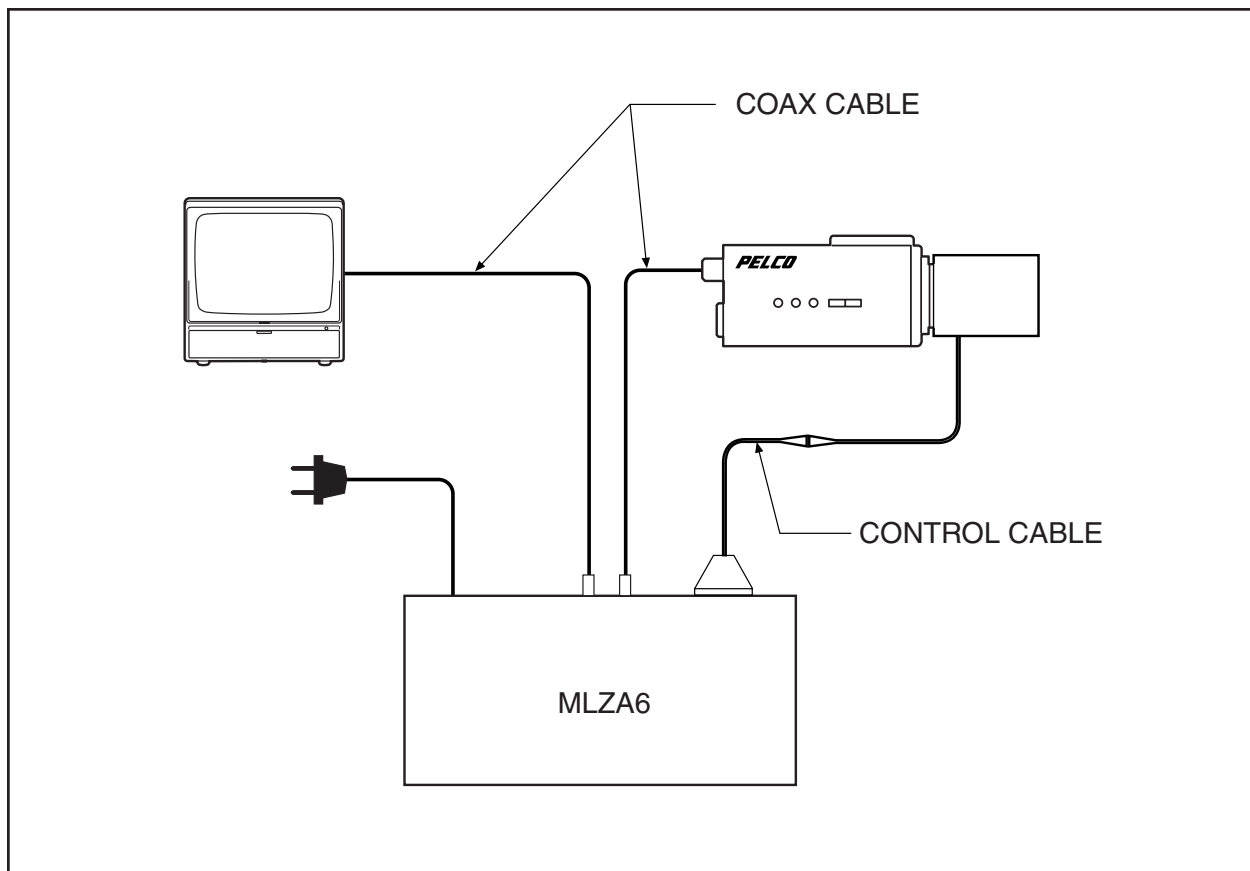

Figure 4. Basic System Configuration

6.0 MAINTENANCE

Under normal operating conditions and usage, maintenance of this equipment is not necessary. However, if maintenance should be required, consult Pelco or a qualified service technician.

NOTE: Pelco offers a 24-hour, seven-days-a-week Technical Assistance Program (TAP) designed to assist any customer with a technical problem involving Pelco equipment whether it's the weekend or late at night. For technical assistance dial **(800) 289-9100** and you will be connected to a Pelco TAP member who is trained to answer your questions.

Pelco also guarantees one-day turnaround on any Pelco equipment sent in for repair. This includes warranty and non-warranty items. Refer to the section on "Warranty and Return Information" in this manual for the proper procedure.

7.0 SCHEMATIC

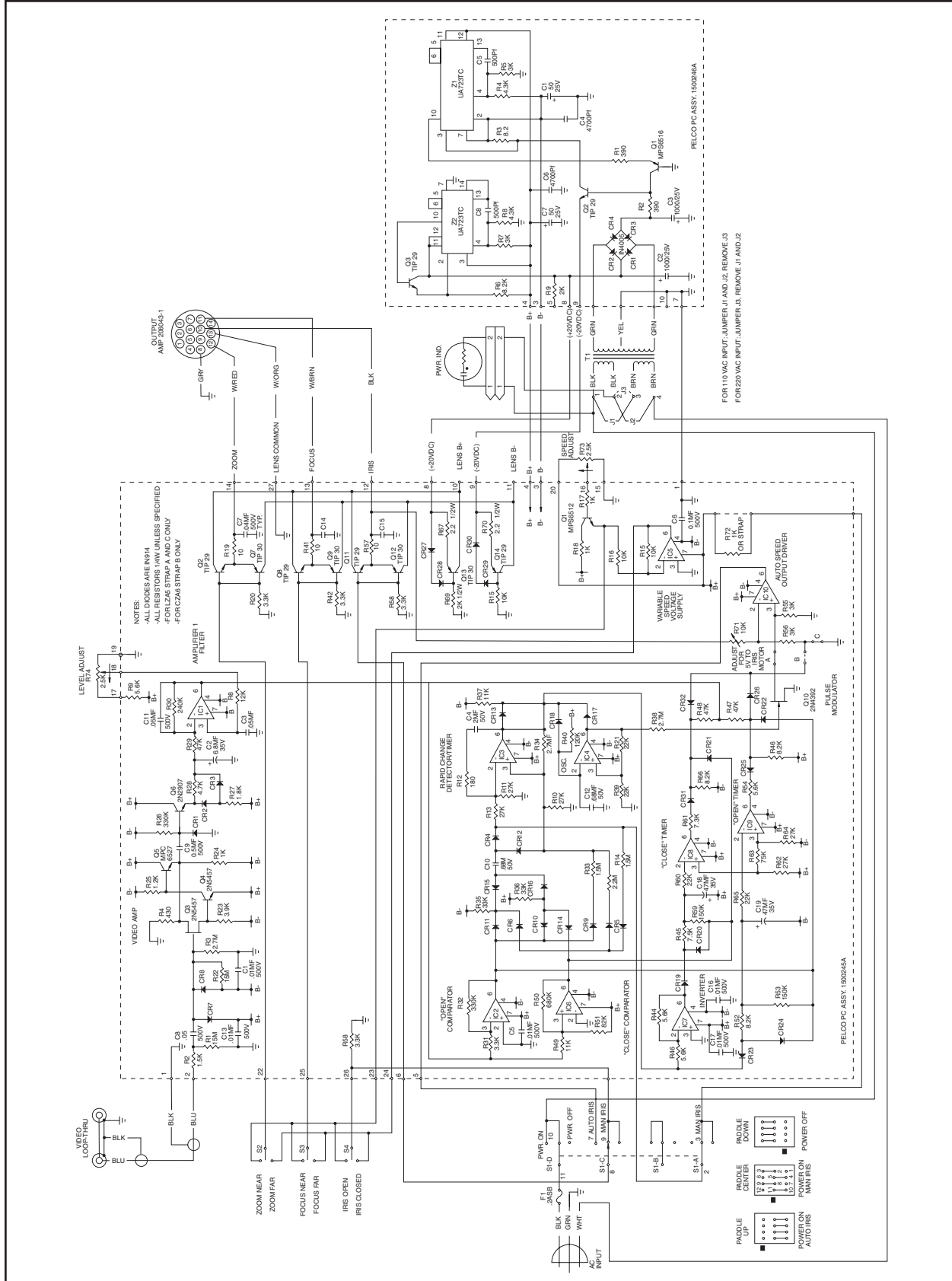

Figure 5. MLZA6DT Schematic

8.0 SPECIFICATIONS

CONTROLS

Zoom:	Paddle switch TELE/WIDE
Focus:	Paddle switch NEAR/FAR
Manual Iris:	Paddle switch OPEN/CLOSE
Auto-Iris:	Paddle switch AUTO/MANUAL
Speed:	Knob adjustment
Video Level:	Knob adjustment
On/Off:	Rocker switch
Pilot Lamp:	Long life neon

ELECTRICAL

Input Voltage:	120 VAC or 230 VAC, 50/60 Hz
Output Voltage:	±2-12 VDC
Power	
Consumption:	3-6 watts
Power Cord:	3-wire grounded, #18 Awg
Output	
Connector:	AMP CPC type, 14 pin (mate supplied)
Circuit:	Full wave power supply with solid-state drive
Iris Drive	High impedance video sampling solid-state control with automatic shutdown at end of travel
Video Level:	Adjustable to 1 volt p-p nominal
Video	
Impedance:	High impedance bridging amplifier
Video	
Connectors:	BNC

Cable	
Requirements:	Four (4) conductors plus ground; one (1) additional conductor for manual override
Cable Distances:	The following distances are approximate maximum recommended under the following conditions: — Based on a 35mA load @ 9VDC — Single lens function activation — Single common conductor in lens cable — 10% loss in voltage at the lens motor
	22 Awg 795 feet (240 m)
	20 Awg 1,265 feet (385 m)
	18 Awg 2,015 feet (615 m)
	16 Awg 3,100 feet (975 m)

NOTE: Video limited to 500 feet (152.4 m) on RG-59 coax cable without equalization amplifier.

GENERAL

Construction:	
Cover	Steel, black polyester powder coat
Chassis	Steel, zinc plated
Panel	Aluminum, black polyester powder coat with white silkscreen
Dimensions	See Figure 6
Weight:	Unit Shipping
MLZA6DT	4 lbs (1.8 kg) 6 lbs (2.7 kg)

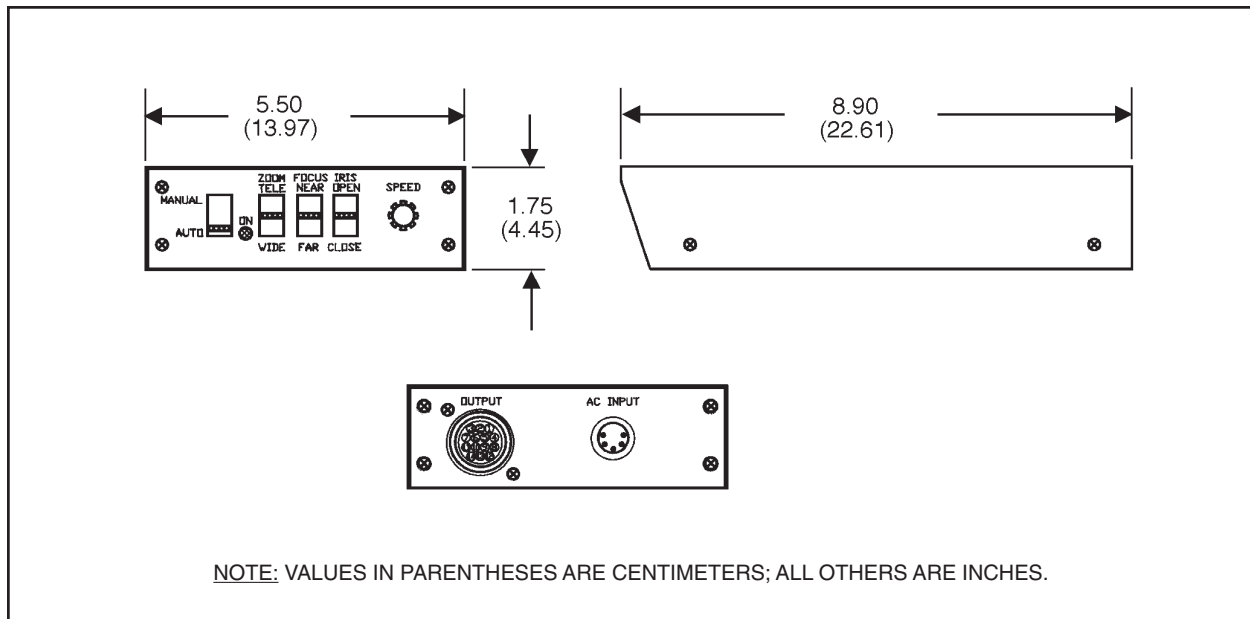

Figure 6. MLZA6DT Dimension Drawing

9.0 WARRANTY AND RETURN INFORMATION

WARRANTY

Pelco will repair or replace, without charge, any merchandise proved defective in material or workmanship for a period of one year after the date of shipment.

Exceptions to this warranty are as noted below:

- Five years on FT/FR8000 Series fiber optic products.
- Three years on Genex® Series products (multiplexers, server, and keyboard).
- Three years on Camclosure® and fixed camera models, except the CC3701H-2, CC3701H-2X, CC3751H-2, CC3651H-2X, MC3651H-2, and MC3651H-2X camera models, which have a five-year warranty.
- Two years on standard motorized or fixed focal length lenses.
- Two years on Legacy®, CM6700/CM6800/CM9700 Series matrix, and DF5/DF8 Series fixed dome products.
- Two years on Spectra®, Esprit®, ExSite™, and PS20 scanners, including when used in continuous motion applications.
- Two years on Esprit® and WW5700 Series window wiper (excluding wiper blades).
- Eighteen months on DX Series digital video recorders, NVR300 Series network video recorders, and Endura™ Series distributed network-based video products.
- One year (except video heads) on video cassette recorders (VCRs). Video heads will be covered for a period of six months.
- Six months on all pan and tilts, scanners or preset lenses used in continuous motion applications (that is, preset scan, tour and auto scan modes).

Pelco will warrant all replacement parts and repairs for 90 days from the date of Pelco shipment. All goods requiring warranty repair shall be sent freight prepaid to Pelco, Clovis, California. Repairs made necessary by reason of misuse, alteration, normal wear, or accident are not covered under this warranty.

Pelco assumes no risk and shall be subject to no liability for damages or loss resulting from the specific use or application made of the Products. Pelco's liability for any claim, whether based on breach of contract, negligence, infringement of any rights of any party or product liability, relating to the Products shall not exceed the price paid by the Dealer to Pelco for such Products. In no event will Pelco be liable for any special, incidental or consequential damages (including loss of use, loss of profit and claims of third parties) however caused, whether by the negligence of Pelco or otherwise.

The above warranty provides the Dealer with specific legal rights. The Dealer may also have additional rights, which are subject to variation from state to state.

If a warranty repair is required, the Dealer must contact Pelco at (800) 289-9100 or (559) 292-1981 to obtain a Repair Authorization number (RA), and provide the following information:

1. Model and serial number
2. Date of shipment, P.O. number, Sales Order number, or Pelco invoice number
3. Details of the defect or problem If there is a dispute regarding the warranty of a product which does not fall under the warranty conditions stated above, please include a written explanation with the product when returned.

Method of return shipment shall be the same or equal to the method by which the item was received by Pelco.



This equipment contains electrical or electronic components that must be recycled properly to comply with Directive 2002/96/EC of the European Union regarding the disposal of waste electrical and electronic equipment (WEEE). Contact your local dealer for procedures for recycling this equipment.

RETURNS

In order to expedite parts returned to the factory for repair or credit, please call the factory at (800) 289-9100 or (559) 292-1981 to obtain an authorization number (CA number if returned for credit, and RA number if returned for repair).

All merchandise returned for credit may be subject to a 20% restocking and refurbishing charge.

Goods returned for repair or credit should be clearly identified with the assigned CA or RA number and freight should be prepaid. Ship to the appropriate address below.

If you are located within the continental U.S., Alaska, Hawaii or Puerto Rico, send goods to:

Service Department
Pelco
3500 Pelco Way
Clovis, CA 93612-5699

If you are located outside the continental U.S., Alaska, Hawaii or Puerto Rico and are instructed to return goods to the USA, you may do one of the following:

If the goods are to be sent by a COURIER SERVICE, send the goods to:

Pelco
3500 Pelco Way
Clovis, CA 93612-5699 USA

If the goods are to be sent by a FREIGHT FORWARDER, send the goods to:

Pelco c/o Expeditors
473 Eccles Avenue
South San Francisco, CA 94080 USA
Phone: 650-737-1700
Fax: 650-737-0933

Free Manuals Download Website

<http://myh66.com>

<http://usermanuals.us>

<http://www.somanuals.com>

<http://www.4manuals.cc>

<http://www.manual-lib.com>

<http://www.404manual.com>

<http://www.luxmanual.com>

<http://aubethermostatmanual.com>

Golf course search by state

<http://golfingnear.com>

Email search by domain

<http://emailbydomain.com>

Auto manuals search

<http://auto.somanuals.com>

TV manuals search

<http://tv.somanuals.com>