

**EA2000**  
**Half-Duplex Equalizing Amplifier**  
**Installation/Operation Manual**  
**C632M (2/88)**

Pelco • 3500 Pelco Way, Clovis, CA 93612-5699 • USA • (800) 289-9100 or (1-559) 292-1981  
FAX (800) 289-9150 or (1-559) 292-3827  
International customers call (1-559) 292-1981 or FAX (1-559) 348-1120

## TABLE OF CONTENTS

<u>Section</u>	<u>Page</u>
1.0 WARNINGS .....	1
2.0 SCOPE .....	2
3.0 DESCRIPTION .....	2
3.1 OPTIONS .....	2
4.0 INSTALLATION .....	2
5.0 OPERATION .....	2
6.0 MAINTENANCE .....	3
7.0 PARTS LIST .....	4
8.0 EXPLODED ASSEMBLY DIAGRAM .....	5
9.0 SCHEMATIC .....	6
10.0 SPECIFICATIONS .....	7
11.0 WARRANTY AND RETURN INFORMATION .....	8

®Pelco and the Pelco logo are registered trademarks of Pelco.  
©Copyright 1988, Pelco. All rights reserved.

## LIST OF ILLUSTRATIONS

<u>Figure</u>		<u>Page</u>
1	Typical Installation Configuration .....	3
2	EA2000 Cable Connections .....	3
3	EA2000 Exploded Assembly Diagram .....	5
4	EA2000 Schematic (PCB9000104) .....	6
5	EA2000 Dimension Drawing .....	7

(This page intentionally left blank.)

INSTALLATION/OPERATION MANUAL  
MODEL EA2000  
HALF-DUPLEX EQUALIZING AMPLIFIER

1.0 WARNINGS

Prior to installation and use of this product, the following WARNINGS should be observed.

1. Installation and servicing should only be done by Qualified Service Personnel and conform to all Local codes.
2. Unless the unit is specifically marked as a NEMA Type 3, 3R, 35, 4, 4X, 6 or 6P enclosure, it is designed for Indoor use only and it must not be installed where exposed to rain and moisture.
3. The product may bear the following marks:

4. Only use replacement parts recommended by Pelco.
5. After replacement/repair of this unit's electrical components, conduct a resistance measurement between line and exposed parts to verify the exposed parts have not been connected to line circuitry.

**This symbol indicates that dangerous voltage constituting a risk of electric shock is present within this unit.**

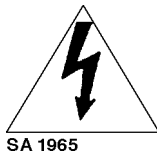

**This symbol indicates that there are important operating and maintenance instructions in the literature accompanying this unit.**



**CAUTION:**  
TO REDUCE THE RISK OF ELECTRICAL SHOCK, DO NOT REMOVE COVER. NO USER-SERVICEABLE PARTS INSIDE. REFER SERVICING TO QUALIFIED SERVICE PERSONNEL.

**CAUTION:**  
RISK OF ELECTRIC SHOCK.  
DO NOT OPEN.

**Please thoroughly familiarize yourself with the information in this manual prior to installation and operation.**

## 2.0 SCOPE

The information contained within this manual covers the installation and operation of the EA2000 Half-duplex Equalizing Amplifier.

## 3.0 DESCRIPTION

The EA2000 is a prioritized, half-duplex equalizing amplifier intended for, but not restricted to, use with Pelco's Coaxitron® System 2000 control.

In the absence of a Coaxitron control signal, the amplifier functions identically to an ordinary unidirectional equalizer, providing up to 8 dB of flat gain and high frequency boost of up to 18 dB at 12 MHz.

In the presence of a control signal, the "forward" equalizing function is temporarily suspended while the control signal is regenerated, pre-equalized and transmitted in the "reverse" direction.

Note that the control direction has priority over the video direction, but that this "interruption" occupies less than one TV line period (excluding sync pulses) and that precautions are taken to insure that the synthetically generated video signal during this interruption does not contain deleterious anomalies.

The EA2000 provides a low cost, highly effective means of maintaining CCTV picture quality in runs of up to 3,000 feet (914 m) of RG59 cable.

Through panel controls provide for adjustable amplifier flat gain of 1-8 dB plus adjustable high frequency boost of from 0 to greater than 18 dB at 12 MHz.

Applications of the EA2000 should be for post-equalization only (located near the Coaxitron transmitter); use as a pre-equalizer is not allowed.

This desk top unit can be rack mounted using the R300 Rack Mount Kit.

### 3.1 OPTIONS

R300	Rack mount kit (up to 3 units can be racked horizontally)
------	---

## 4.0 INSTALLATION

The EA2000 is designed to be used for post equalization only (located near the Coaxitron transmitter); use as a pre-equalizer is not allowed.

Figure 1 illustrates a typical system installation.

For installation, perform the following steps:

1. Connect the video cable from the Coaxitron receiver to the connector marked "INPUT" on the rear panel.
2. Connect a video cable from the connector marked "OUTPUT" to the Coaxitron transmitter (see Figure 2).

The EA2000 is supplied with a U.L. listed wall transformer which plugs into a 120 VAC outlet and supplies the 12 VAC to operate the unit.

## 5.0 OPERATION

Optimum performance is achieved if an oscilloscope and a standard EIA resolution chart are used in making gain and boost adjustments. The GAIN control should be adjusted for an output level to 1 volt p-p and the L.F. BOOST control should be adjusted for minimum tilt during sync pulses. The H.F. BOOST control is then adjusted for optimum resolution wedge reproduction.

If the use of a resolution chart is precluded, the H.F. BOOST control should be adjusted for maximum sharpness of sync pulse edges — without overshoot.

In the absence of an oscilloscope, a less precise (but often equally satisfactory) adjustment can be made as follows:

1. Set the GAIN and BOOST controls approximately 1/3 turn from fully counterclockwise.
2. Adjust GAIN control for satisfactory overall picture contrast.
3. Adjust L.F. BOOST control for optimum detail. Too much boost (clockwise) can cause picture instability and/or smearing (trail).
4. Adjust the H.F. BOOST control to further optimize picture detail. Note that the effectiveness of this control is hardly perceptible unless very fine picture detail is present in the camera signal output. An excessive setting of this control (clockwise) can, however, increase picture noise.

## 6.0 MAINTENANCE

Under normal operating conditions and usage, maintenance of this equipment is not necessary. The EA2000 has no operator serviceable components and should be serviced by a trained technician or returned to the factory for repair.

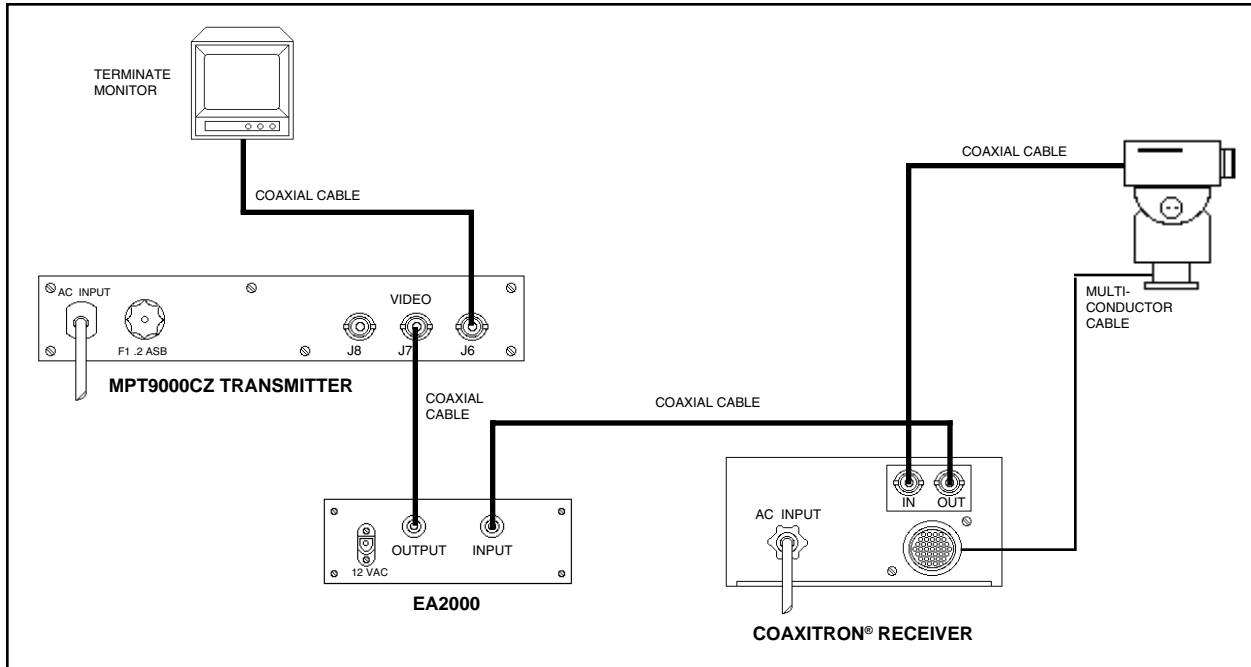

**Figure 1.** Typical Installation Configuration

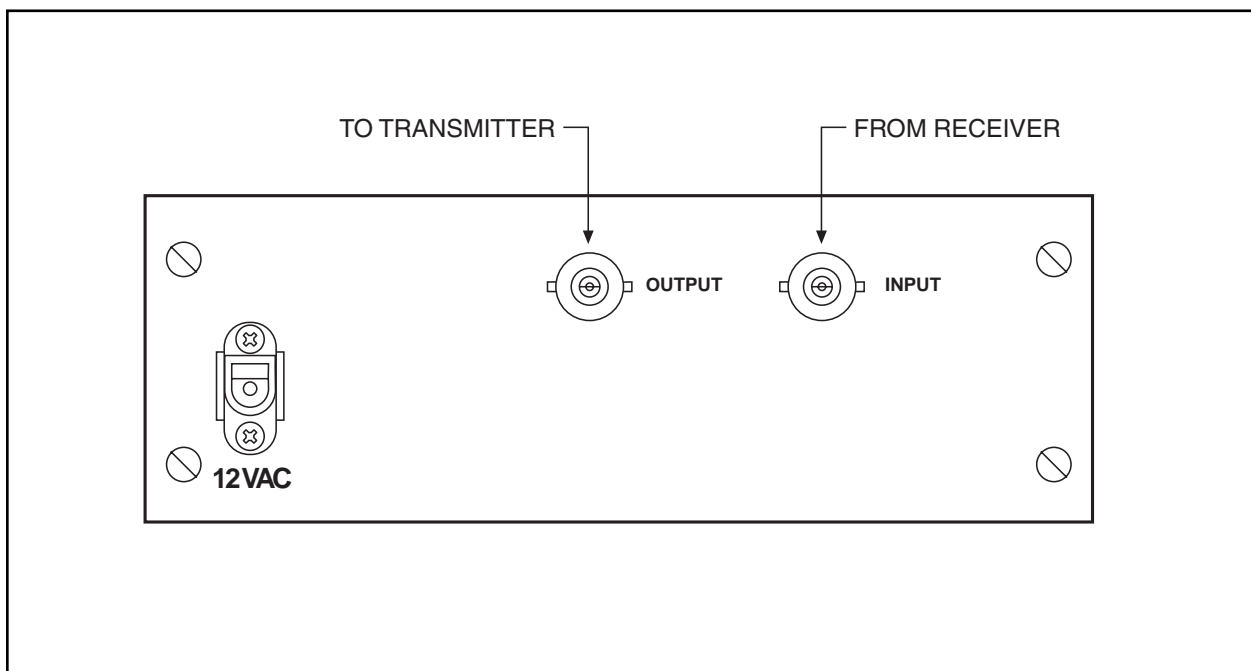

**Figure 2.** EA2000 Cable Connections

## 7.0 PARTS LIST

The following list corresponds to the exploded assembly diagram in Figure 3.

Item	Qty	Description	Part Number
1	1	Connector, DC power jack #16 PJ221	CON16PJ421
2	2	Connector MTA 2-position cable w/socket	CON640428-2
3	1	Connector MTA 3-position cable w/socket	CON640428-3
4	2	Connector, BNC CP1094ULNSD CAM00	CONUG1094/U
5	1	Chassis, univ M1CA	M1CA4001COMP
6	1	Chassis cover, univ M1CA	M1CA4001COMP
7	1	Panel front, EA2000	PANEA4004COMP
8	1	PCB assembly, half-duplex equalizer	PCB9000104ASSY
9	1	Panel, rear EA2000	RPEA4000COMP
10	4	Spacer, 1/4" hex x .375 4-40 tap	SPA8402
11		Not used	
12	1	Lug, BNC ground	ZH1497
13	2	Screw, 2-56 x 3/16" pan slot SS	ZH2-56X.187SPS
14	8	Screw, 4-40 x 1/4" pan Philips SS	ZH4-40X.250SPP15
15	8	Screw, 4-40 x 3/8" pan Philips Blk	ZH4-40X.375BPP
16	4	Screw, 4-40 x 3/8" pan Philips SS	ZH4-40X.375SPP
17	12	Washer, internal star #4 SS	ZH4LWSIS



## 8.0 EXPLODED ASSEMBLY DIAGRAM

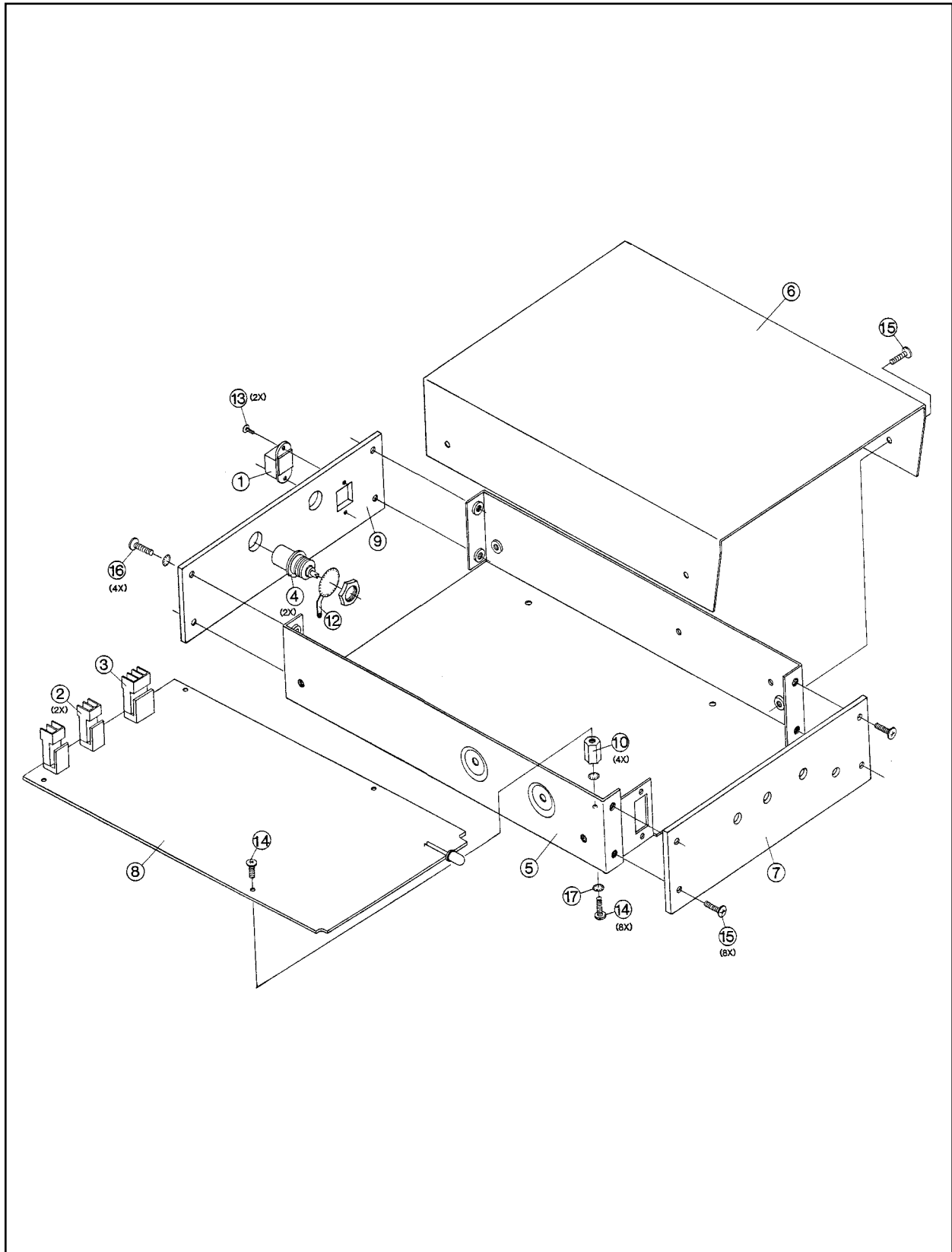

**Figure 3.** EA2000 Exploded Assembly Diagram

# 9.0 SCHEMATIC

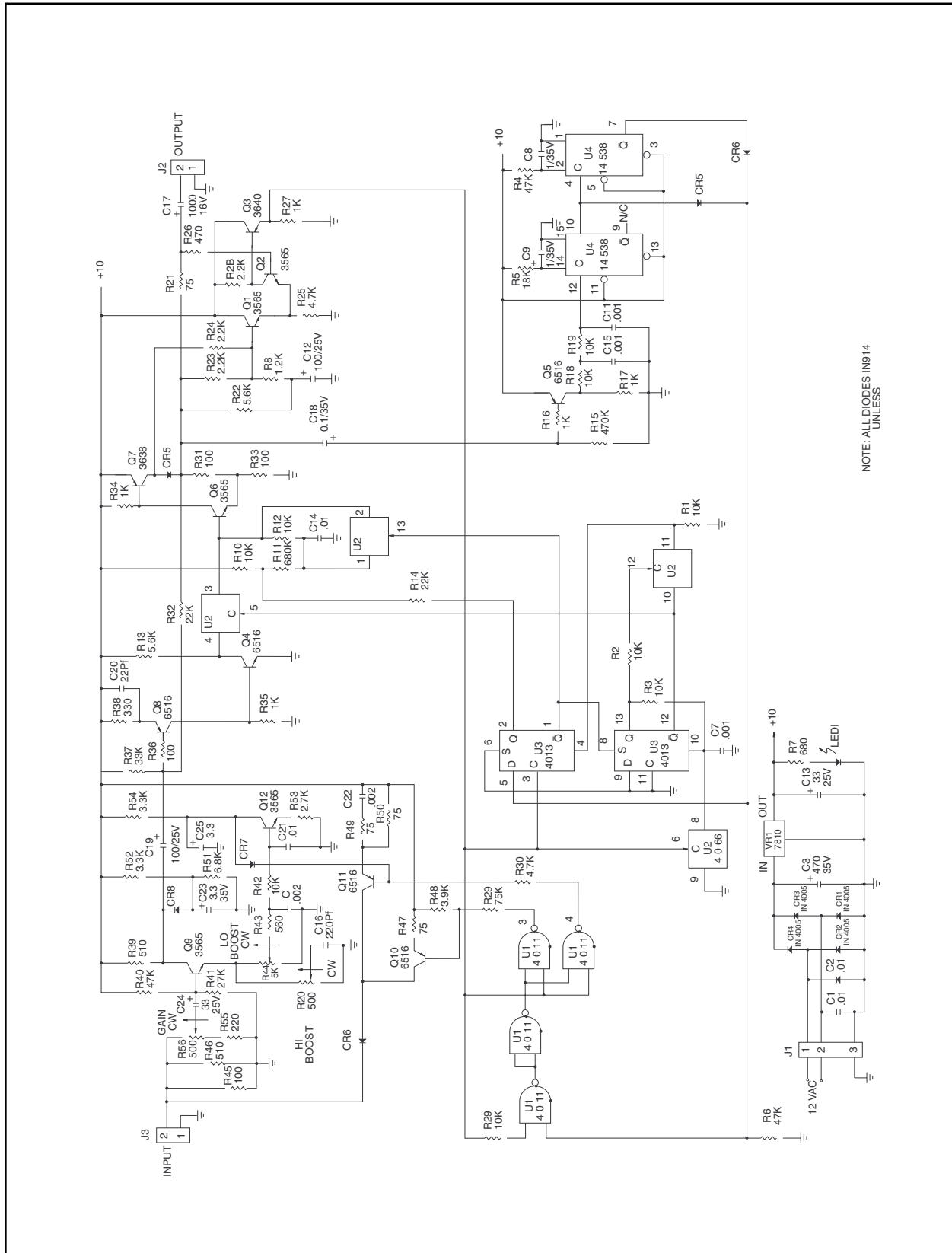

Figure 4. EA2000 Schematic (PCB9000104)

## 10.0 SPECIFICATIONS

### MODEL

EA2000 Half-duplex Equalizing Video/Control Amplifier. (UL)

EA2000/220 Same as EA2000 except 230 VAC operation. (CE)

### ELECTRICAL

Input: Single (BNC) internally terminated in 75 ohms

Output: Single (BNC) source terminated

Frequency Response: Adjustable from flat ( $\pm 1$  dB) at 12 MHz to greater than 18 dB of boost at 12 MHz

Gain: Adjustable from 1–8 dB

Output Dynamic Range: Up to 2 volts p-p at 50% APL  
Up to 1.5 volts p-p at 90% APL

Tilt: Less than 2%

### Power Requirements

for Transformer: 1.5 vA (.125 amp) at  $12 \pm 15\%$  volts RMS 50-60 Hz from a dedicated, isolated source

### Cable Lengths:

Cable Type	Maximum Effective Distance
RG59	3,000 feet (914.4 m)
RG6	4,500 feet (1371.6 m)
RG11	6,000 feet (1828.8 m)
RG15	8,000 feet (2438.4 m)

### GENERAL

Environment: 32° to 122°F (0 to 48.89°C)  
0-90% relative humidity

Dimensions: see Figure 5

Weight: 3 lbs (1.35 kg)

Shipping Weight: 4 lbs (1.81 kg)

Construction: Chassis Steel, zinc plated

Cover Aluminum, black polyester powder coat

Panel Aluminum, black polyester powder coat with white silk screening

Rating: NEMA 1

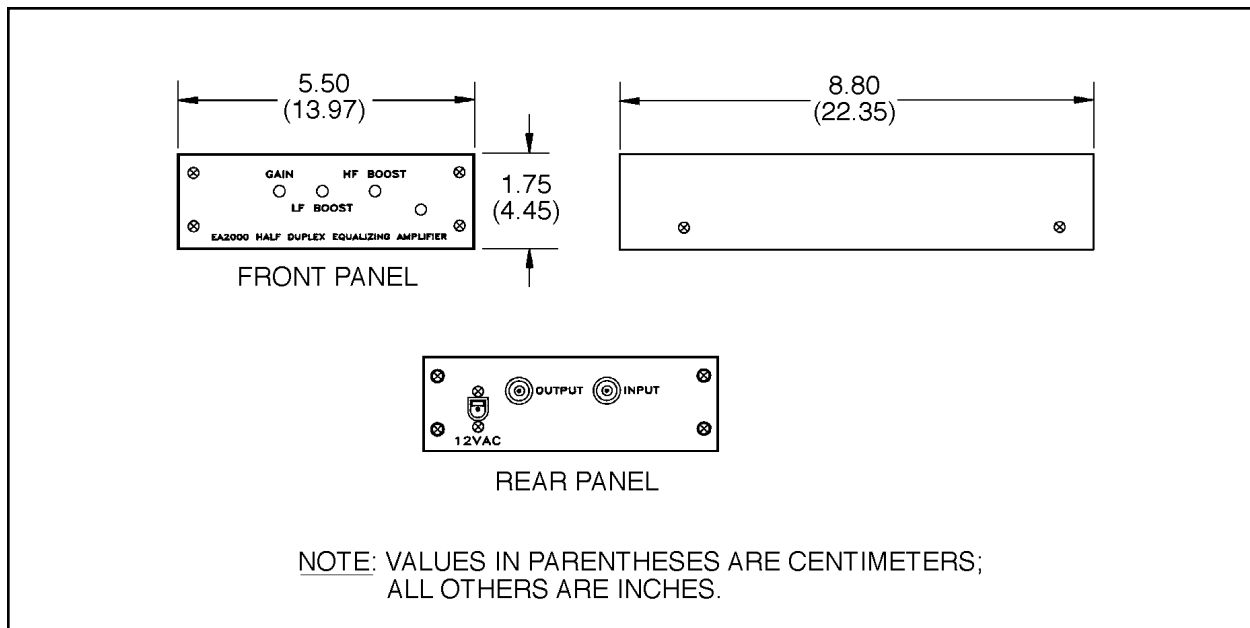

**Figure 5.** EA2000 Dimension Drawing

## 11.0 WARRANTY AND RETURN INFORMATION

### WARRANTY

Pelco will repair or replace, without charge, any merchandise proved defective in material or workmanship for a period of one year after the date of shipment.

Exceptions to this warranty are as noted below:

- Five years on FT/FR8000 Series fiber optic products.
- Three years on Genex® Series products (multiplexers, server, and keyboard).
- Three years on Camclosure® and fixed camera models, except the CC3701H-2, CC3701H-2X, CC3751H-2, CC3651H-2X, MC3651H-2, and MC3651H-2X camera models, which have a five-year warranty.
- Two years on standard motorized or fixed focal length lenses.
- Two years on Legacy®, CM6700/CM6800/CM9700 Series matrix, and DF5/DF8 Series fixed dome products.
- Two years on Spectra®, Esprit®, ExSite™, and PS20 scanners, including when used in continuous motion applications.
- Two years on Esprit® and WW5700 Series window wiper (excluding wiper blades).
- Eighteen months on DX Series digital video recorders, NVR300 Series network video recorders, and Endura™ Series distributed network-based video products.
- One year (except video heads) on video cassette recorders (VCRs). Video heads will be covered for a period of six months.
- Six months on all pan and tilts, scanners or preset lenses used in continuous motion applications (that is, preset scan, tour and auto scan modes).

Pelco will warrant all replacement parts and repairs for 90 days from the date of Pelco shipment. All goods requiring warranty repair shall be sent freight prepaid to Pelco, Clovis, California. Repairs made necessary by reason of misuse, alteration, normal wear, or accident are not covered under this warranty.

Pelco assumes no risk and shall be subject to no liability for damages or loss resulting from the specific use or application made of the Products. Pelco's liability for any claim, whether based on breach of contract, negligence, infringement of any rights of any party or product liability, relating to the Products shall not exceed the price paid by the Dealer to Pelco for such Products. In no event will Pelco be liable for any special, incidental or consequential damages (including loss of use, loss of profit and claims of third parties) however caused, whether by the negligence of Pelco or otherwise.

The above warranty provides the Dealer with specific legal rights. The Dealer may also have additional rights, which are subject to variation from state to state.

If a warranty repair is required, the Dealer must contact Pelco at (800) 289-9100 or (559) 292-1981 to obtain a Repair Authorization number (RA), and provide the following information:

1. Model and serial number
2. Date of shipment, P.O. number, Sales Order number, or Pelco invoice number
3. Details of the defect or problem

If there is a dispute regarding the warranty of a product which does not fall under the warranty conditions stated above, please include a written explanation with the product when returned.

Method of return shipment shall be the same or equal to the method by which the item was received by Pelco.

### RETURNS

In order to expedite parts returned to the factory for repair or credit, please call the factory at (800) 289-9100 or (559) 292-1981 to obtain an authorization number (CA number if returned for credit, and RA number if returned for repair).

All merchandise returned for credit may be subject to a 20% restocking and refurbishing charge.

Goods returned for repair or credit should be clearly identified with the assigned CA or RA number and freight should be prepaid. Ship to the appropriate address below.

If you are located within the continental U.S., Alaska, Hawaii or Puerto Rico, send goods to:

Service Department  
Pelco  
3500 Pelco Way  
Clovis, CA 93612-5699

If you are located outside the continental U.S., Alaska, Hawaii or Puerto Rico and are instructed to return goods to the USA, you may do one of the following:

If the goods are to be sent by a COURIER SERVICE, send the goods to:

Pelco  
3500 Pelco Way  
Clovis, CA 93612-5699 USA

If the goods are to be sent by a FREIGHT FORWARDER, send the goods to:

Pelco c/o Expeditors  
473 Eccles Avenue  
South San Francisco, CA 94080 USA  
Phone: 650-737-1700  
Fax: 650-737-0933

## Free Manuals Download Website

<http://myh66.com>

<http://usermanuals.us>

<http://www.somanuals.com>

<http://www.4manuals.cc>

<http://www.manual-lib.com>

<http://www.404manual.com>

<http://www.luxmanual.com>

<http://aubethermostatmanual.com>

Golf course search by state

<http://golfingnear.com>

Email search by domain

<http://emailbydomain.com>

Auto manuals search

<http://auto.somanuals.com>

TV manuals search

<http://tv.somanuals.com>