

**PT506-24DT
Pan/Tilt
Lens Control
PT506-24A
Auto/Random
Scan Control**

**Installation/
Operation Manual**

C580M Rev D (9/97)

Pelco • 3500 Pelco Way • Clovis, CA 93612-5699 • USA • www.pelco.com
In North America and Canada: Tel (800) 289-9100 • FAX (800) 289-9150
International Customers: Tel (1-559) 292-1981 or FAX (1-559) 348-1120

CONTENTS

Section	Page
1.0 GENERAL	1
1.1 IMPORTANT SAFEGUARDS AND WARNINGS	1
2.0 DESCRIPTION	2
2.1 MODELS	2
2.2 OPTIONS	2
3.0 INSTALLATION	3
3.1 RECOMMENDED CABLE DISTANCES	3
3.2 CONNECTOR ASSEMBLY	5
4.0 OPERATION	6
4.1 OPERATIONAL TEST — PT506-24DT	6
4.2 OPERATIONAL TEST — PT506-24A	7
5.0 MAINTENANCE	8
6.0 SCHEMATICS	9
7.0 SPECIFICATIONS	14
8.0 WARRANTY AND RETURN INFORMATION	16

LIST OF ILLUSTRATIONS

Figure		Page
1	PT506-24DT Basic System Configuration	3
2	PT506-24DT Configured with PT506-24A	4
3	PT506-24DT Configured with a Relay Box	4
4	Connector Assembly	5
5	PT506-24DT Schematics (Sheet 1 of 5)	9
	PT506-24DT Schematics (Sheet 2 of 5)	10
	PT506-24DT Schematics (Sheet 3 of 5)	11
	PT506-24DT Schematics (Sheet 4 of 5)	12
	PT506-24DT Schematics (Sheet 5 of 5)	13
6	PT506/PT506-24A Dimension Drawing	15

LIST OF TABLES

Table		Page
A	PT506-24A Duty Cycle Combinations	7

(This page intentionally left blank.)

1.0 GENERAL

1.1 IMPORTANT SAFEGUARDS AND WARNINGS

Prior to installation and use of this product, the following WARNINGS should be observed.

1. Installation and servicing should only be done by Qualified Service Personnel and conform to all Local codes.
2. Unless the unit is specifically marked as a NEMA Type 3, 3R, 3S, 4, 4X, 6 or 6P enclosure, it is designed for Indoor use only and it must not be installed where exposed to rain and moisture.
3. Only use replacement parts recommended by Pelco.
4. After replacement/repair of this unit's electrical components, conduct a resistance measurement between line and exposed parts to verify the exposed parts have not been connected to line circuitry.

The product and/or manual may bear the following marks:



This symbol indicates that dangerous voltage constituting a risk of electric shock is present within this unit.



This symbol indicates that there are important operating and maintenance instructions in the literature accompanying this unit.

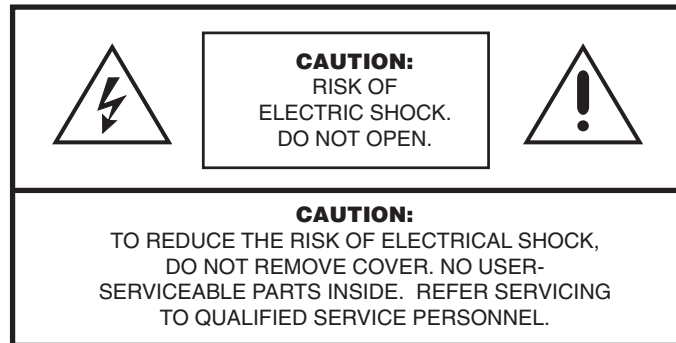

Please thoroughly familiarize yourself with the information in this manual prior to installation and operation.

2.0 DESCRIPTION

The PT506-24DT is a pan/tilt and lens control designed to remotely operate 24 VAC pan/tilts and all Pelco motorized zoom lenses. This unit can control up to six (6) different locations, all of which can be selected by pressing the corresponding illuminated push-button switch. The pan/tilt movement is controlled by an eight position joystick. The lens functions and speed are controlled by three momentary paddle switches and a rotary knob.

The PT506-24A provides the auto/random scan control to the PT506-24DT. Random Scan is a significant advance in CCTV security/surveillance protection that makes continuous duty auto scan operation virtually obsolete. Random Scan is an effective deterrent to would-be intruders because it follows no predictable pattern. The scan direction varies randomly as does the scanning time and dwell time (4-60 seconds). Random scan makes it impossible for intruders to "beat the system" because it has none.

Random Scan is not only a powerful weapon to protect your premises, but it also increases your equipment life by over 100% while decreasing maintenance costs. Its shorter duty cycle reduces gear train and drive motor wear, cable fatigue, and motor temperature rise. Random Scan also offers you the flexibility of continuous auto scan option with a time delay that automatically returns operations to Random Scan after 30 minutes in continuous auto scan.

2.1 MODELS

PT506-24DT	Multiple position desk top joystick control, 120 VAC operation, for up to 6 pan/tilts (24 VAC) and zoom lenses. For use with PT270-24P, PT280-24P, PT280-24SL, PT180-24P, PT180-24SL, PT175-24P, PT570-24P, PT680-24P, and PT680-24SL.
PT506-24DT/220	Same as PT506-24DT except 230 VAC operation. (CE)
PT506-24A	Desk top auto/random scan control; interfaces with PT506-24DT.

2.2 OPTIONS

RB24	Relay box for 24 VAC Pan/tilts. Extends operating distance (control to relay box) up to 14,500 ft (4,419 m) utilizing 16 Awg.
RB115	Relay box for 120 VAC pan/tilts. Allows control to be used with 120 VAC pan/tilts and extends operating distance (one required for each pan/tilt).

3.0 INSTALLATION

Figure 1 shows a typical rear panel installation of the PT506-24DT controller. The distance from the controller is limited by the wire size and pan/tilt used. (See Section 3.1 Recommended Cable Distances.)

Figure 2 shows a typical rear panel installation of the PT506-24A to the PT506-24DT.

Figure 3 shows a typical system using a relay box to extend the pan/tilt control range and operate a 120 VAC pan/tilt.

3.1 RECOMMENDED CABLE DISTANCES

The following typical values are based on the conditions as follows:

- Single common conductor for the lens
- Single common conductor for the pan/tilt
- Maximum rated load
- 10% voltage reduction from line loss
- Simultaneous pan/tilt activation (2 amp current draw)

Wire Size	Pan/Tilt	Lens Functions
22 Awg	40 ft (10 m)	620 ft (182 m)
20 Awg	60 ft (18 m)	1,000 ft (294 m)
18 Awg	95 ft (30 m)	2,300 ft (676 m)
16 Awg	150 ft (45 m)	3,600 ft (1,058 m)

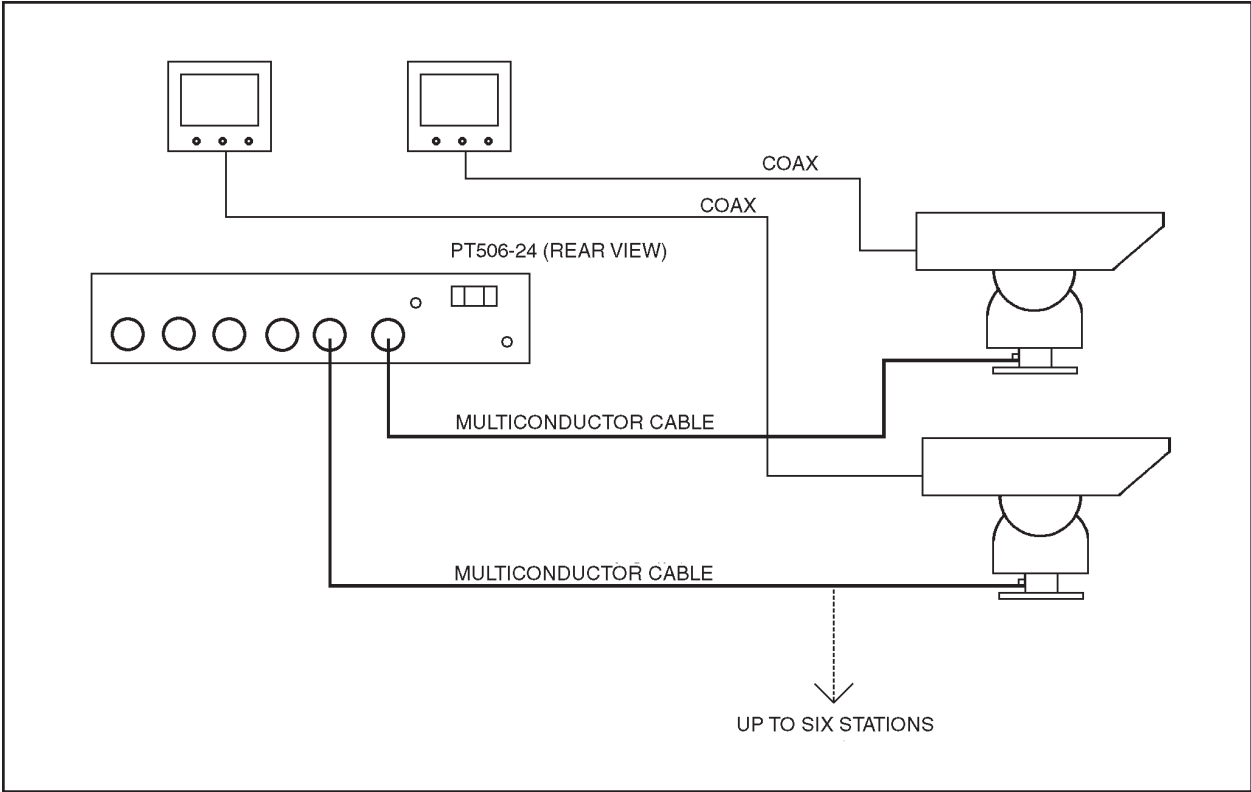

Figure 1. PT506-24DT Basic System Configuration

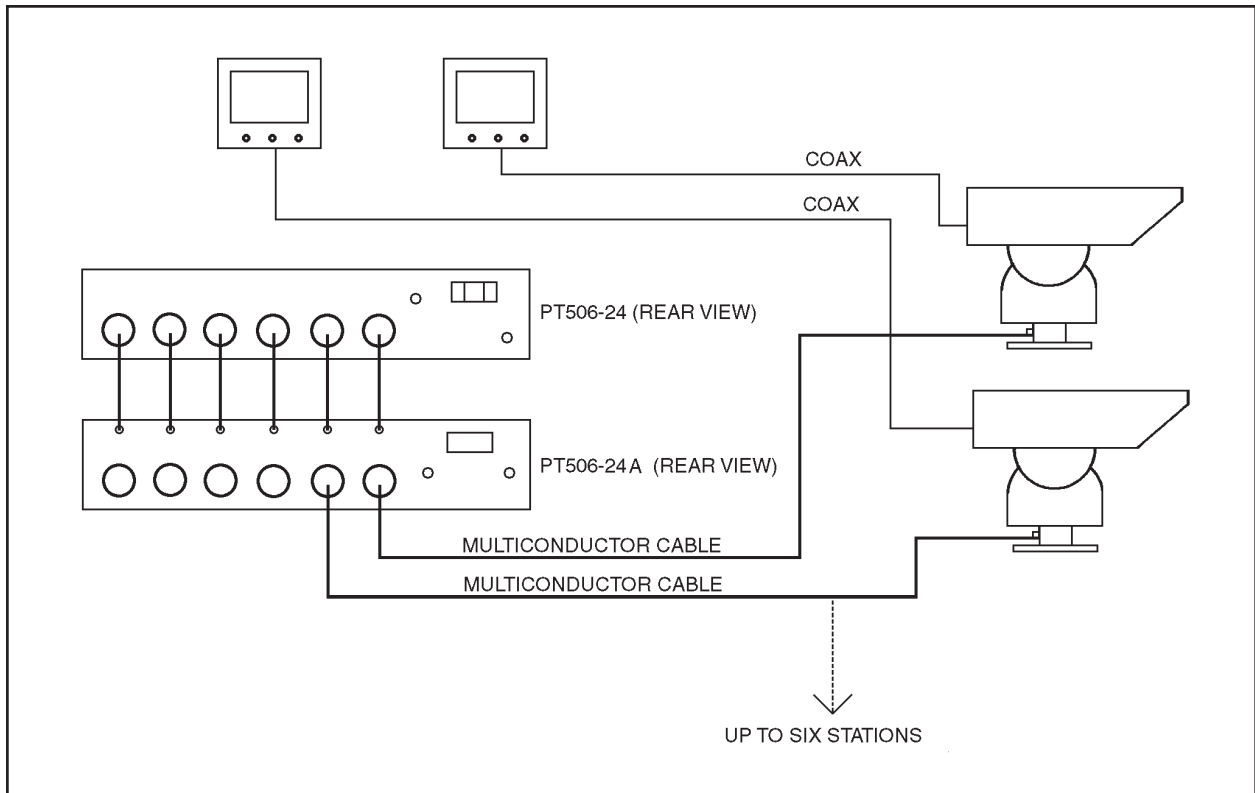

Figure 2. PT506-24DT Configured with PT506-24A

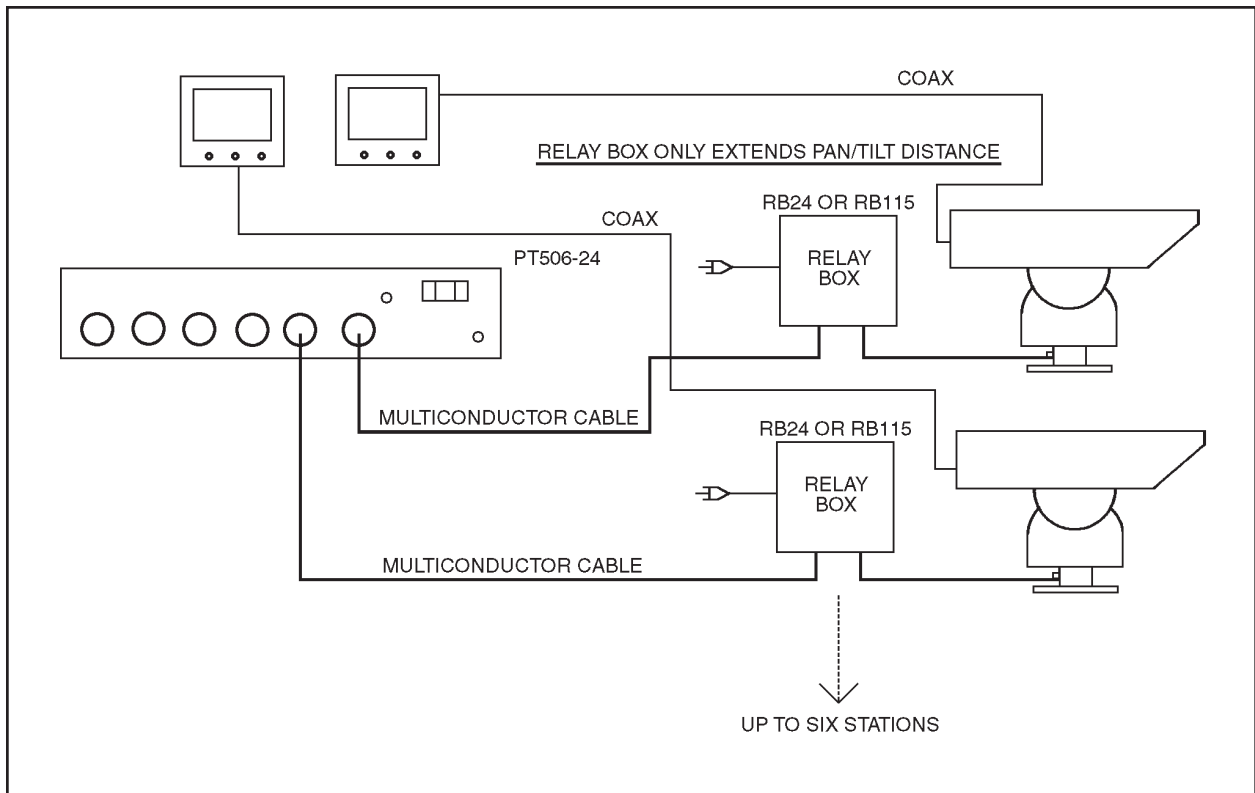

Figure 3. PT506-24DT Configured with a Relay Box

3.2 CONNECTOR ASSEMBLY

Assemble the connector parts according to the instructions below. Detail B, below, reflects the pin arrangement specific to all PT506-24DT Pan/Tilt and Lens Control and the PT506-24A Auto/Random Scan Control. Refer to Figure 4 during assembly. For best results use an AMP style crimper when making the wire to pin connection.

The instructions that follow apply to all AMP style connectors regardless of pin size or pin number.

1. Slide the connector clamp assembly over the conductor cable. If the diameter of the conductor cable is such that the rubber boot will slide over it easily then slide the rubber boot onto the conductor cable at this time. If not, discard the rubber boot.
2. Prepare the wires from the conductor cable as follows:
 - a. Strip at least 1" from the cable jacket to expose the wires. You may need to strip more from the cable jacket if you have more wires.
 - b. Strip 1/8" from each wire.
 - c. Using an AMP style crimper, crimp the wires and their insulation to the connector pins. Refer to Detail A in Figure 4.
3. Slide the connector pins into the appropriate holes in the connector body until they snap into place. Refer to Figure 4 for correct pin arrangement, depending on model and options.
4. Push the connector clamp assembly (with boot, if used) toward the connector body. Screw the clamp assembly onto the connector body, being careful not to disturb the wires.
5. To complete the assembly, attach the appropriate clamp with the screws provided and tighten.

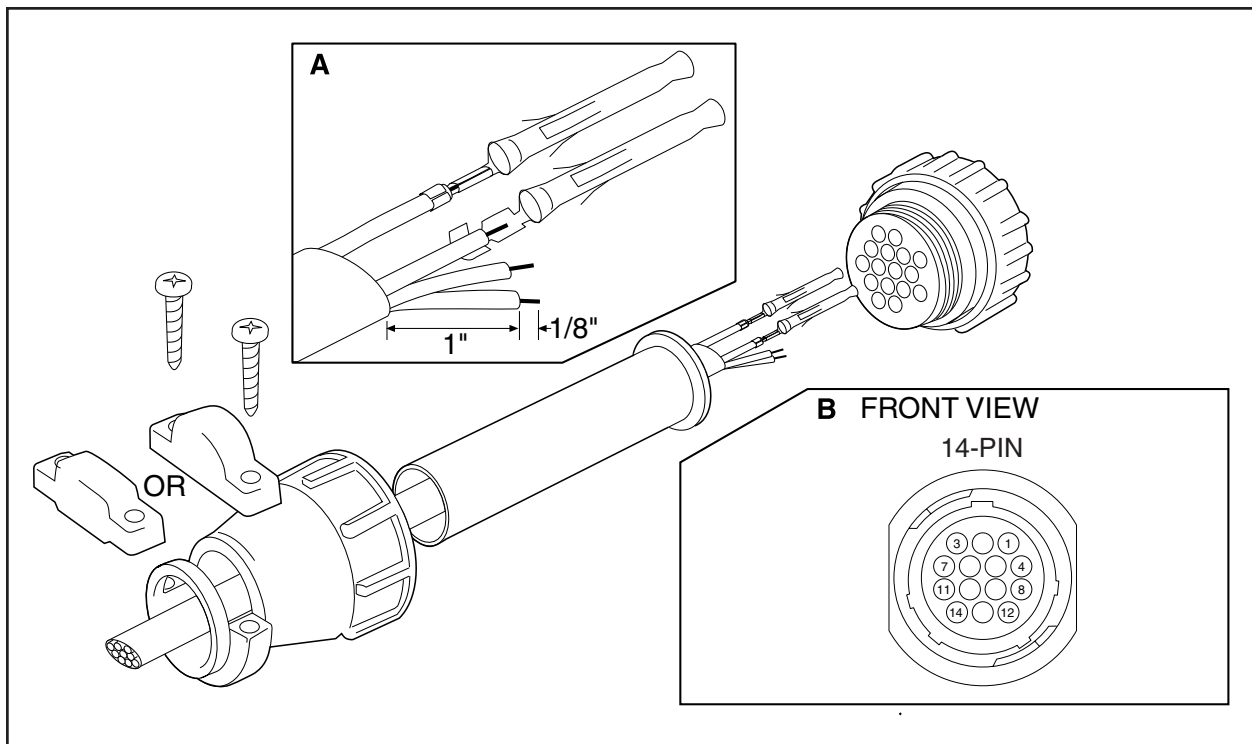

Figure 4. Connector Assembly

4.0 OPERATION

The PT506-24DT will not allow control of any of the six pan/tilt stations until one is selected by pressing the desired station on the latching selection switches. Once a selection has been made, the switch will illuminate and all control functions will be available only to that particular station. It is considered that all pan/tilt and lens control functions are self-explanatory. Refer to Section 4.1, OPERATIONAL TEST—PT506-24DT, for details of each control function.

The PT506-24A will allow each pan/tilt station to have auto/random scan operation. Each station can be put into auto/random mode by pushing the paddle switch “up” for the corresponding station.

4.1 OPERATIONAL TEST — PT506-24DT

After installing the interconnecting cable between the pan/tilt and control, plug the control into a 120 VAC outlet, turn the control on, and test operation using the following procedure:

1. Select a station.
2. Move the joystick to the “UP” position; the front of the tilt table should move upwards. Move the joystick to the “DOWN” position; the front of the tilt table should move downwards.
3. Move the joystick to the “LEFT” position; the unit should pan to the left (clockwise). With the joystick at the “RIGHT” position, the unit should pan to the right (counterclockwise).
4. Test operation of the diagonal positions of the joystick, which combine both pan and tilt functions simultaneously. For example, moving the joystick diagonally to the left between “LEFT” and “UP” should pan the unit to the left and move the tilt table up.
5. Test Zoom operations by moving the paddle switch “UP” for the TELE operation and “DOWN” for the WIDE operation.
6. Test Focus operations by moving the paddle switch “UP” for NEAR FOCUS and “DOWN” for FAR FOCUS.
7. Test Iris operations by moving the paddle switch “UP” for IRIS OPEN and “DOWN” for IRIS CLOSE.
8. Rotate the lens speed knob and test for fast and slow speeds of all lens functions by observing their operation as the knob is adjusted.
9. Select another station and repeat steps 1 through 8.

4.2 OPERATIONAL TEST — PT506-24A

The PT506-24A will add two modes of automatic pan operation to the PT506-24DT. Once the PT506-24A is interconnected as shown in Figure 2, apply power to the units. When the corresponding paddle switch to the station selected is in the down or middle position, manual control of the pan functions can be obtained. All units power-up in the "manual" mode. Once the switch is momentarily pressed "UP", the selected station goes into random scan mode. This causes scanning between limits in an unpredictable pattern.

The duration of scan varies randomly between approximately 0 and 60 seconds. At the completion of a scan period, a dwell (or rest) period occurs. This dwell period varies randomly between about 4 seconds and an adjustable 60 to 900 seconds.

The PT506-24A is factory preset for a duty cycle of 50%. However, Random Scan dwell time is adjustable by installation or removal of diodes CR9, 10, & 11 on PCB1500530. Table A shows the available duty cycle combinations.

At the completion of a dwell period, another scan period is started. The direction of this scan period is also randomly determined. When a pan limit is reached, scan direction is reversed automatically.

Table A. PT506-24A Duty Cycle Combinations

CR 11	CR 9	CR 10	DUTY CYCLE
0	0	0	50.00%
0	0	1	25.00%
0	1	0	17.00%
0	1	1	12.50%
1	0	0	10.00%
1	0	1	8.00%
1	1	0	7.00%
1	1	1	6.25%

Where: 1 = Diode in circuit
0 = Diode out of circuit

CONTINUOUS AUTO SCAN

For continuous AUTO SCAN, press "AUTO/RANDOM" a second time. After approximately one half-hour in Auto Scan, the unit automatically reverts to Random Scan.

Manual operation can be activated by moving the joystick while the unit is in Auto or Random Scan.

NOTE: Pressing "AUTO/RANDOM" while in Random Scan causes a shift to Auto Scan and starts the half-hour timer. Similarly, pressing "AUTO-RANDOM" while in Auto Scan causes a shift to Random Scan and zeros the half-hour timer.

5.0 MAINTENANCE

Under normal operating conditions and usage, maintenance of this equipment is not necessary. However, if maintenance is required, repairs should be performed by a qualified service technician or equipment should be returned to the factory for repair.

NOTE: *Pelco offers a 24-hour, seven-day-a week Technical Assistance Program (TAP) designed to assist any customer with a technical problem involving Pelco equipment whether it's the weekend or late at night. For technical assistance dial (800) 289-9100 and you will be connected to a Pelco TAP member who is trained to answer your questions.*

Pelco also guarantees one-day turnaround on any Pelco equipment sent in for repair. This includes warranty and non-warranty items. Refer to the section on "Warranty and Return Information" in this manual for the proper procedure.

6.0 SCHEMATICS

If necessary, refer to the following schematics for troubleshooting or repair

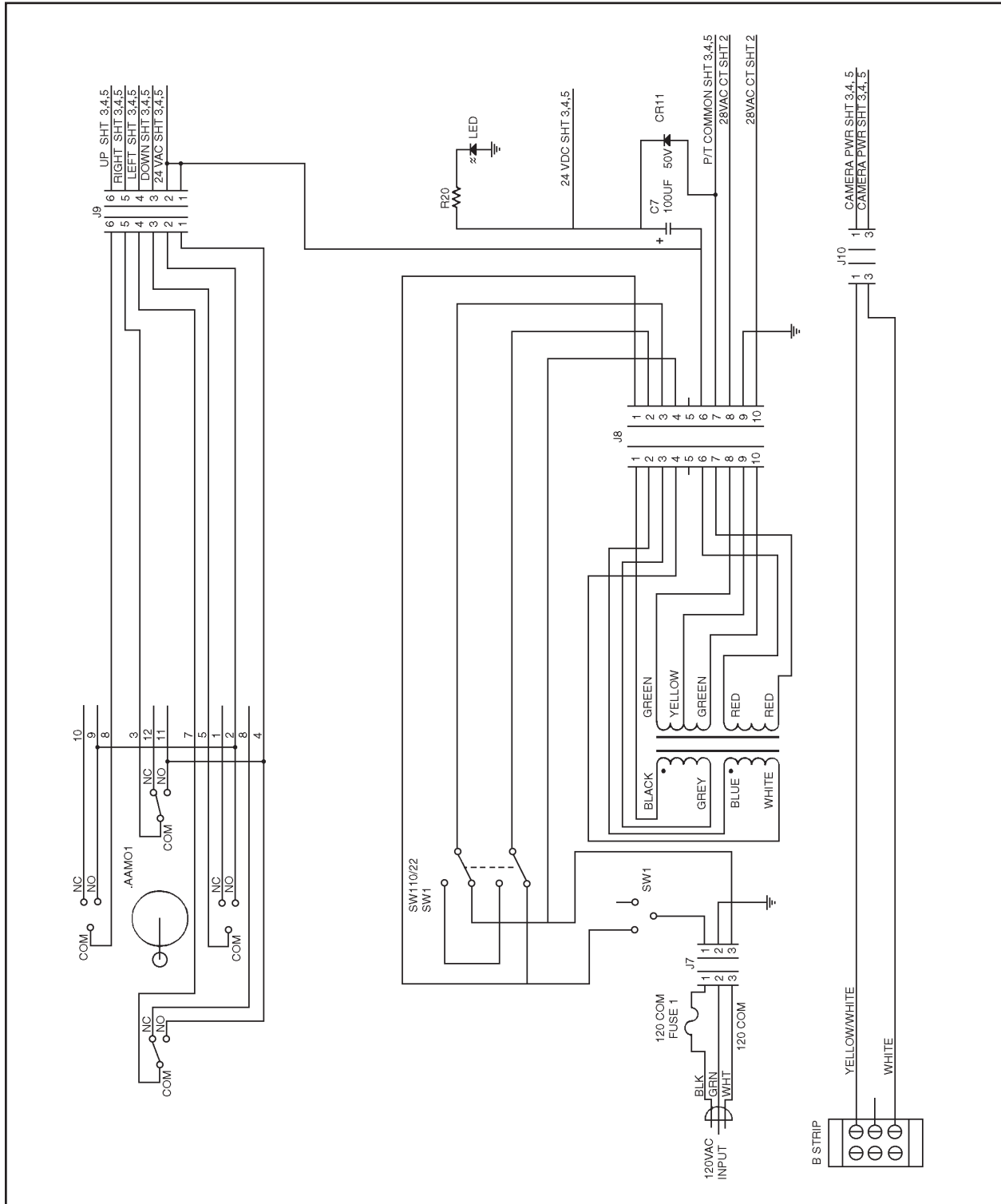

Figure 5. PT506-24DT Schematics (Sheet 1 of 5)

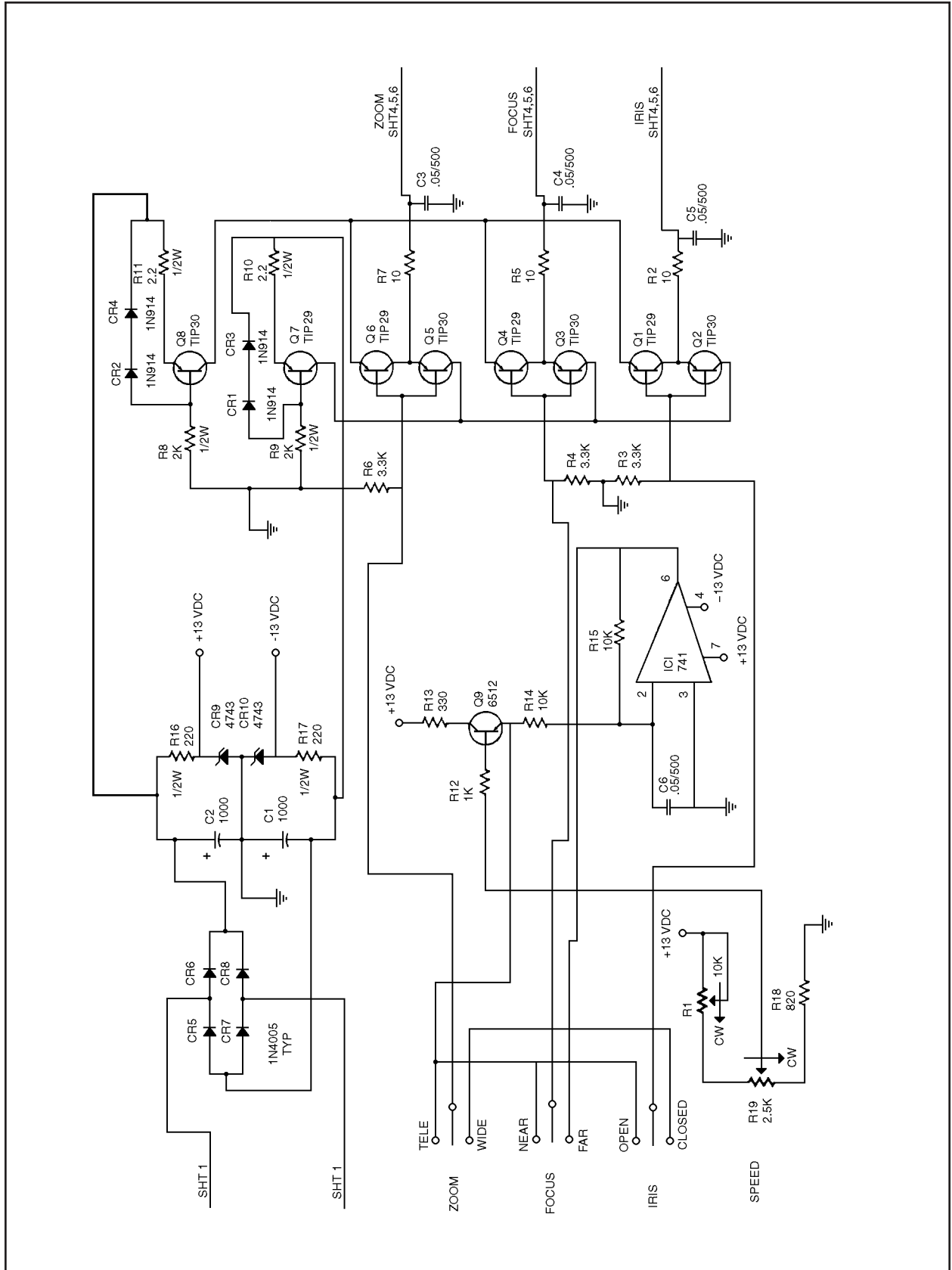

Figure 5. PT506-24DT Schematics (Sheet 2 of 5)

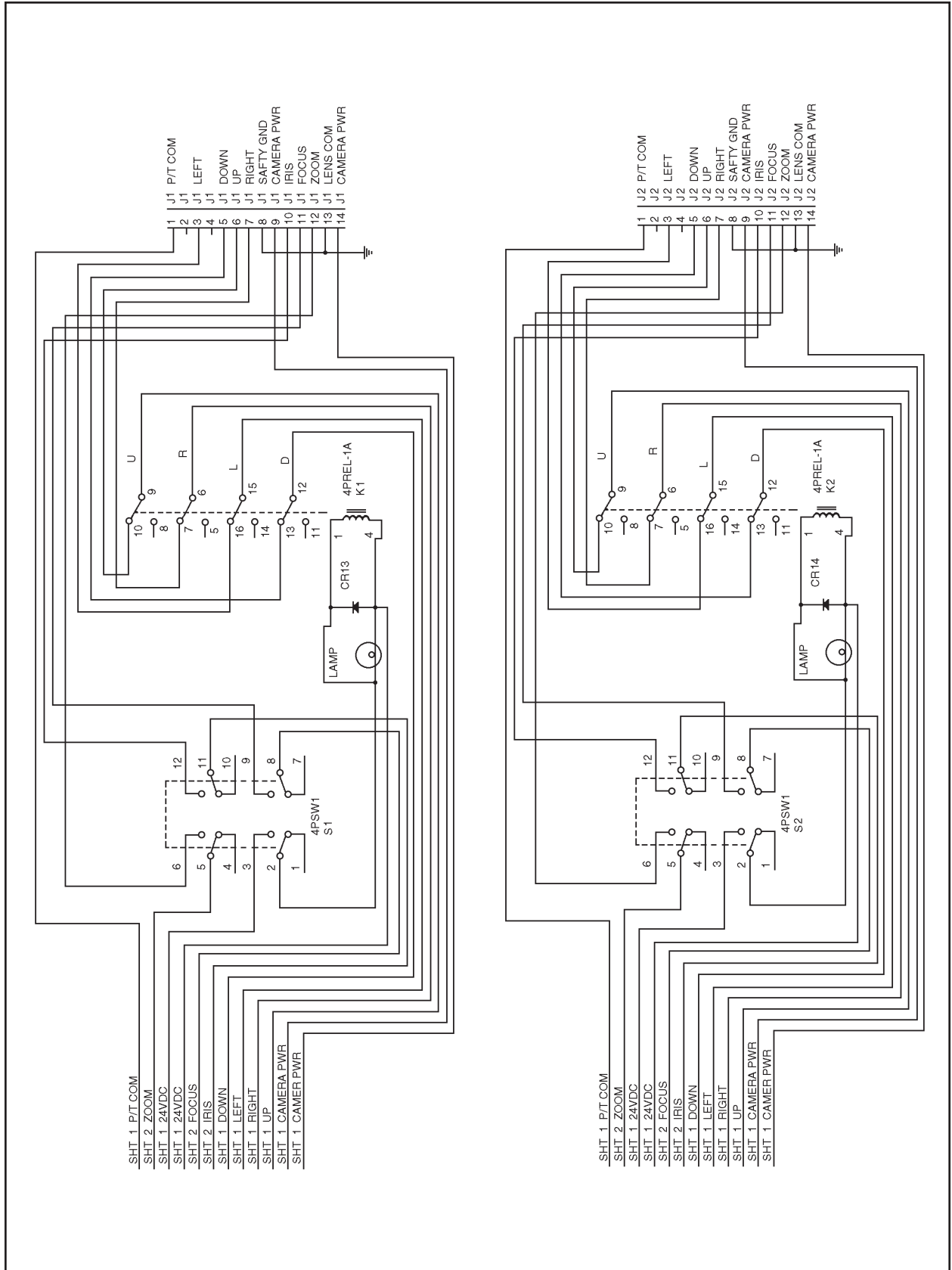

Figure 5. PT506-24DT Schematics (Sheet 3 of 5)

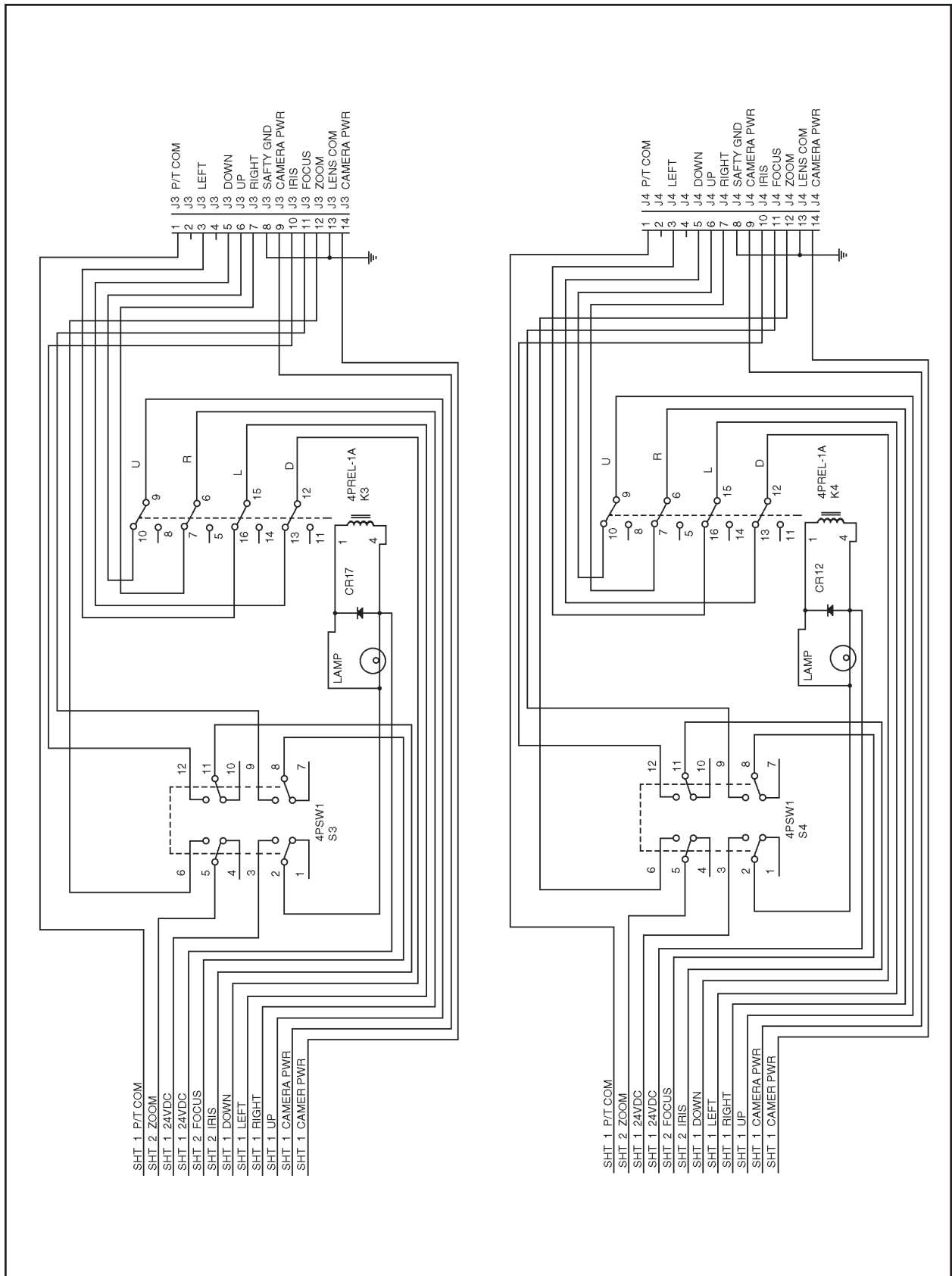

Figure 5. PT506-24DT Schematics (Sheet 4 of 5)

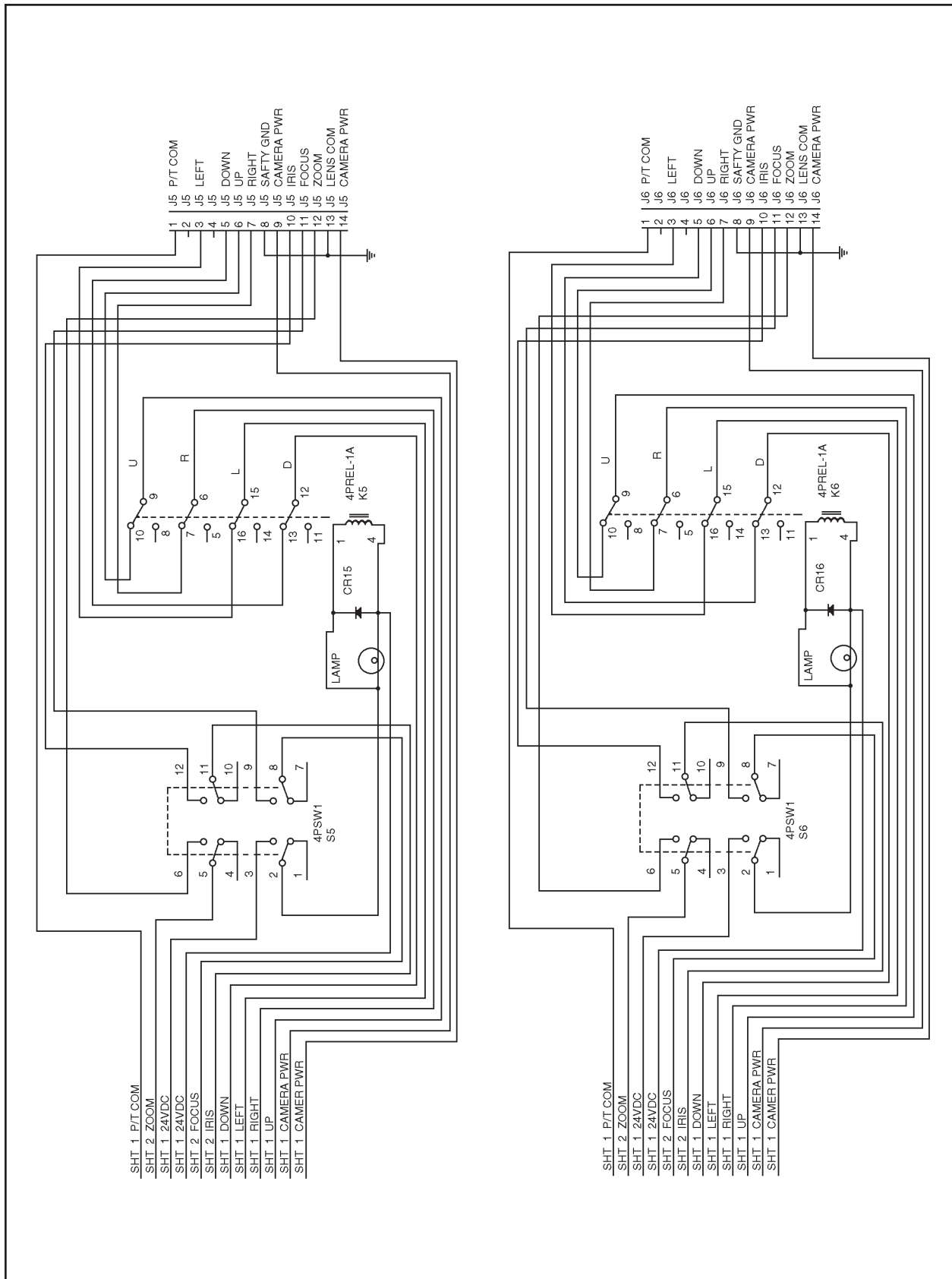

Figure 5. PT506-24DT Schematics (Sheet 5 of 5)

7.0 SPECIFICATIONS

ELECTRICAL

PT506-24DT

Input Voltage:	120 VAC, 50/60 Hz (230 VAC optional)
Output Voltage:	24 VAC, 60 Hz pan/tilt supply 0 to \pm 9 VDC lens supply
Power Requirement:	1.65 amps (190 vA)
Cable Requirements:	11 conductors (Pan/tilt 5 + ground; Lens 4 + ground)
Fuse Protection:	2 AG type 1ASB
Power Cord:	3-wire grounded #18 Awg
Connectors:	AMP CPC type (mate supplied)
Replacement Lamps:	Station Select Switch replacement lamp #LAP72524

PT506-24A

Power Requirements:	1.04 amps (120 vA)
Protection:	3 AG, 2 amps
Power Cord:	3-wire grounded

CONTROLS

PT506-24DT

Pan/Tilt Selection:	6 latching, illuminated push buttons
Pan/Tilt:	8 position joystick (UP, DOWN, LEFT, RIGHT, and simultaneous combinations for pan/tilt when joystick is moved diagonally.)
Zoom:	Paddle switch, TELE/WIDE
Focus:	Paddle switch, NEAR/FAR
Iris:	Paddle switch, OPEN/CLOSE
Lens Speed:	Potentiometer
On/Off:	Rocker switch
Pilot Lamp:	Light emitting diode

PT506-24A

On/Off:	Rocker switch
Auto/Random:	6 Rocker switches (one for each pan/tilt); 2 operational positions (Auto/Random and Manual)

GENERAL

Enclosure Construction

Panel: Aluminum
 Cover: Steel, textured black enamel
 Chassis: Steel, galvanized

Temperature

Range: 32° to 120°F (0° to 50°C)

Size:

See Figure 6

Weight

PT506-24DT 13 lbs 6 oz (6 kg)
 PT506-24A 18 lbs (8.1 kg)

Shipping Weight

PT506-24DT 14 lbs 6 oz (6.5 kg)
 PT506-24A 19 lbs (8.5 kg)

Rating:

NEMA 1

(Design and product specifications subject to change without notice.)



This equipment contains electrical or electronic components that must be recycled properly to comply with Directive 2002/96/EC of the European Union regarding the disposal of waste electrical and electronic equipment (WEEE). Contact your local dealer for procedures for recycling this equipment.

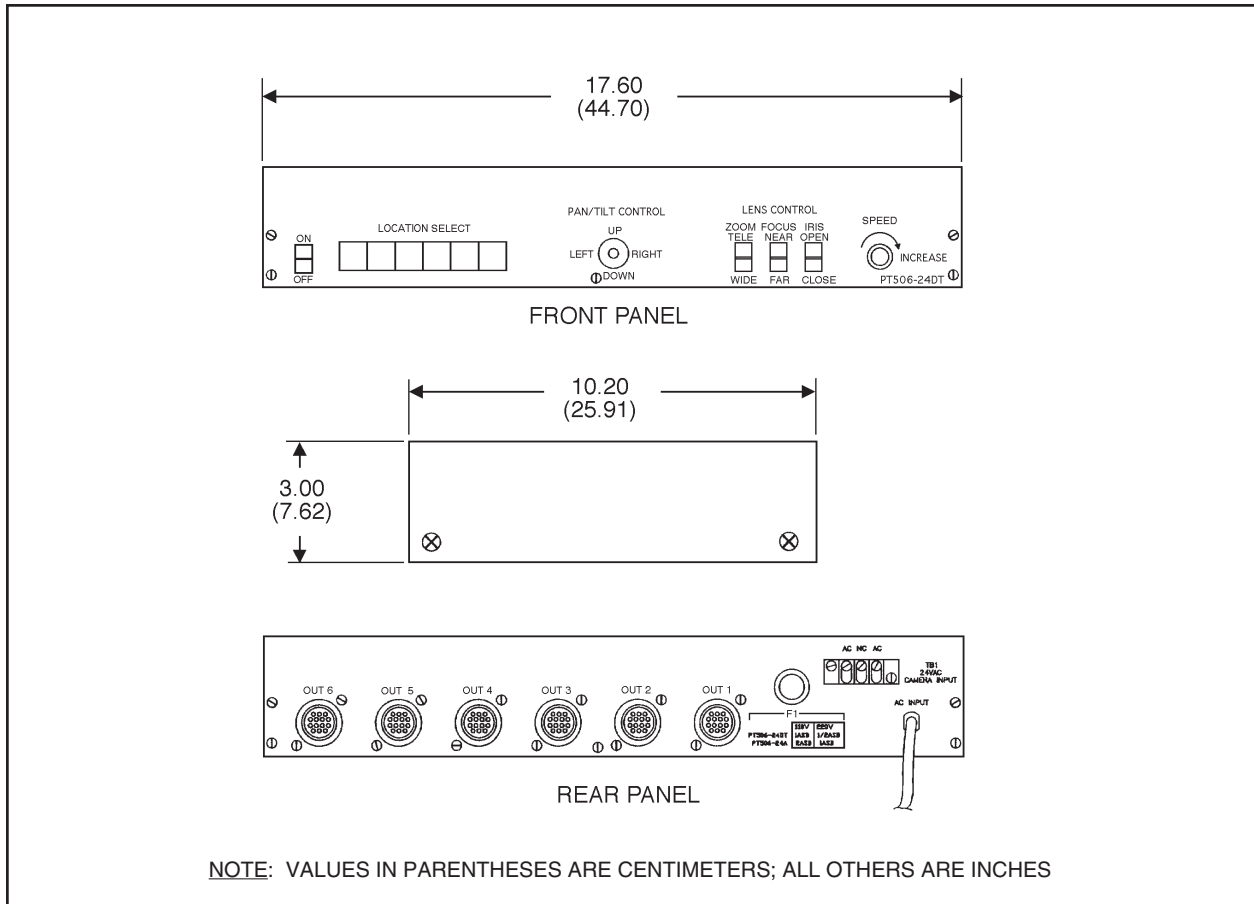

Figure 6. PT506/PT506-24A Dimension Drawing

8.0 WARRANTY AND RETURN INFORMATION

WARRANTY

Pelco will repair or replace, without charge, any merchandise proved defective in material or workmanship for a period of one year after the date of shipment.

Exceptions to this warranty are as noted below:

- Five years on FT/FR8000 Series fiber optic products.
- Three years on Genex® Series products (multiplexers, server, and keyboard).
- Three years on Camclosure® and fixed camera models, except the CC3701H-2, CC3701H-2X, CC3751H-2, CC3651H-2X, MC3651H-2, and MC3651H-2X camera models, which have a five-year warranty.
- Two years on standard motorized or fixed focal length lenses.
- Two years on Legacy®, CM6700/CM6800/CM9700 Series matrix, and DF5/DF8 Series fixed dome products.
- Two years on Spectra®, Esprit®, ExSite™, and PS20 scanners, including when used in continuous motion applications.
- Two years on Esprit® and WW5700 Series window wiper (excluding wiper blades).
- Eighteen months on DX Series digital video recorders, NVR300 Series network video recorders, and Endura™ Series distributed network-based video products.
- One year (except video heads) on video cassette recorders (VCRs). Video heads will be covered for a period of six months.
- Six months on all pan and tilts, scanners or preset lenses used in continuous motion applications (that is, preset scan, tour and auto scan modes).

Pelco will warrant all replacement parts and repairs for 90 days from the date of Pelco shipment. All goods requiring warranty repair shall be sent freight prepaid to Pelco, Clovis, California. Repairs made necessary by reason of misuse, alteration, normal wear, or accident are not covered under this warranty.

Pelco assumes no risk and shall be subject to no liability for damages or loss resulting from the specific use or application made of the Products. Pelco's liability for any claim, whether based on breach of contract, negligence, infringement of any rights of any party or product liability, relating to the Products shall not exceed the price paid by the Dealer to Pelco for such Products. In no event will Pelco be liable for any special, incidental or consequential damages (including loss of use, loss of profit and claims of third parties) however caused, whether by the negligence of Pelco or otherwise.

The above warranty provides the Dealer with specific legal rights. The Dealer may also have additional rights, which are subject to variation from state to state.

If a warranty repair is required, the Dealer must contact Pelco at (800) 289-9100 or (559) 292-1981 to obtain a Repair Authorization number (RA), and provide the following information:

1. Model and serial number
2. Date of shipment, P.O. number, Sales Order number, or Pelco invoice number
3. Details of the defect or problem

If there is a dispute regarding the warranty of a product which does not fall under the warranty conditions stated above, please include a written explanation with the product when returned.

Method of return shipment shall be the same or equal to the method by which the item was received by Pelco.

RETURNS

In order to expedite parts returned to the factory for repair or credit, please call the factory at (800) 289-9100 or (559) 292-1981 to obtain an authorization number (CA number if returned for credit, and RA number if returned for repair).

All merchandise returned for credit may be subject to a 20% restocking and refurbishing charge. Goods returned for repair or credit should be clearly identified with the assigned CA or RA number and freight should be prepaid. Ship to the appropriate address below.

If you are located within the continental U.S., Alaska, Hawaii or Puerto Rico, send goods to:

Service Department
Pelco
3500 Pelco Way
Clovis, CA 93612-5699

If you are located outside the continental U.S., Alaska, Hawaii or Puerto Rico and are instructed to return goods to the USA, you may do one of the following:

If the goods are to be sent by a COURIER SERVICE, send the goods to:

Pelco
3500 Pelco Way
Clovis, CA 93612-5699 USA

If the goods are to be sent by a FREIGHT FORWARDER, send the goods to:

Pelco c/o Expeditors
473 Eccles Avenue
South San Francisco, CA 94080 USA
Phone: 650-737-1700
Fax: 650-737-0933

Pelco, the Pelco logo, Camclosure, Esprit, Genex, Legacy, and Spectra are registered trademarks of Pelco.

Endura and ExSite are trademarks of Pelco.

© Copyright 1997, Pelco. All rights reserved.

Free Manuals Download Website

<http://myh66.com>

<http://usermanuals.us>

<http://www.somanuals.com>

<http://www.4manuals.cc>

<http://www.manual-lib.com>

<http://www.404manual.com>

<http://www.luxmanual.com>

<http://aubethermostatmanual.com>

Golf course search by state

<http://golfingnear.com>

Email search by domain

<http://emailbydomain.com>

Auto manuals search

<http://auto.somanuals.com>

TV manuals search

<http://tv.somanuals.com>