

**PT1280P Series
Pan/Tilts**

**Installation/
Operation Manual**

C379M-G (12/98)

Pelco • 3500 Pelco Way, Clovis • CA 93612-5699 USA • www.pelco.com
In North America and Canada: Tel (800) 289-9100 or FAX (800) 289-9150
International Customers: Tel (1-559) 292-1981 or FAX (1-559) 348-1120

CONTENTS

Section	Page
1.0 GENERAL	5
1.1 IMPORTANT SAFEGUARDS AND WARNINGS	5
2.0 DESCRIPTION	6
2.1 MODELS	6
2.2 OPTIONS	6
2.3 CERTIFICATIONS	6
3.0 INSTALLATION	7
3.1 MOUNTING	7
3.2 CAMERA/ENCLOSURE MOUNTING	7
3.3 WIRING	7
3.3.1 Mating Connector Assembly	9
3.4 LIMIT STOP ADJUSTMENTS	14
4.0 OPERATION	15
5.0 TROUBLESHOOTING	15
5.1 SERVICE MANUAL	15
6.0 MAINTENANCE	16
6.1 TIGHTENING DRIVE CHAINS	16
6.2 CHAIN DRIVE LUBRICATION	16
6.3 MOTOR BRAKE REPLACEMENT	17
7.0 SPECIFICATIONS	18
8.0 WARRANTY AND RETURN INFORMATION	20

LIST OF ILLUSTRATIONS

Figure	Page
1 Sealant Locations	7
2 Connector Assembly	9
3 PT1280P/PT1280SL Wiring Diagram	10
4 PT1280P/HB Wiring Diagram	11
5 PT1280P/PP Wiring Diagram	12
6 PT1280SL/PP Wiring Diagram	13
7 Limit Stops	14
8 Servicing the Pan/Tilt	16
9 Dimension Drawing	19

LIST OF TABLES

Table	Page
A Maximum Cable Distances	8
B Recommended Cable Distances Using RB115 Relay Box	8

REVISION HISTORY

Manual #	Date	Comments
C379M	8/87	Original version.
C379M	6/90	Rev. A. New format, options edited, mounting information added, wiring diagram added.
C379M	1/91	Rev. B. Wiring diagram for the PT1280P/PP added, warning section added, additional mounting information added, cable requirements expanded to include 7 conductors using 2-wire motor common.
C379M	11/91	Rev. C. Table of contents added, electrical specs updated.
C379M	2/92	Rev. D. New PT1280SL/PP wiring diagram added. Associated specs and drawings updated.
C379M	9/92	Rev. E. New models added, associated options updated; associated specs updated, wiring diagrams added.
C379M-F	1/95	Rev. F. Revised to 2-column format. Portions of the mounting section were rewritten. In accordance with ECO 93-153, new diagrams added to replace the old cable distance and connector assy diagrams. New wiring diagrams added for figures 3,4,5 & 6. Note expanded on limit/stop adjustment. New and updated exploded assembly diagrams for figures 10,11,12 & 13. Associated parts and hardware call outs added.
	1/96	Revised Figure 6 to show correct wire colors for pins 19 and 20.
C379M-G	12/98	Changed manual to new format. Added certifications. Revised installation instructions. Moved exploded assembly diagrams and parts lists to maintenance/service manual. In wiring schematics incorporated 8/1/96 addendum. Expanded section on motor brake replacement.

(This page intentionally left blank.)

1.0 GENERAL

1.1 IMPORTANT SAFEGUARDS AND WARNINGS

Prior to installation and use of this product, the following WARNINGS should be observed.

1. Installation and servicing should only be done by qualified service personnel and conform to all local codes.
2. Unless the unit is specifically marked as a NEMA Type 3, 3R, 3S, 4, 4X, 6 or 6P enclosure, it is designed for Indoor use only and it must not be installed where exposed to rain and moisture.
3. The weight of the camera, lens, and enclosure shall not exceed 100 lb (45.4 kg).
4. Only use replacement parts recommended by Pelco.
5. After replacement/repair of this unit's electrical components, conduct a resistance measurement between line and exposed parts to verify the exposed parts have not been connected to line circuitry.
6. The installation method and materials should be capable of supporting four times the weight of the enclosure, pan/tilt, camera and lens combination.

The product and/or manual may bear the following marks:



This symbol indicates that dangerous voltage constituting a risk of electric shock is present within this unit.



This symbol indicates that there are important operating and maintenance instructions in the literature accompanying this unit.

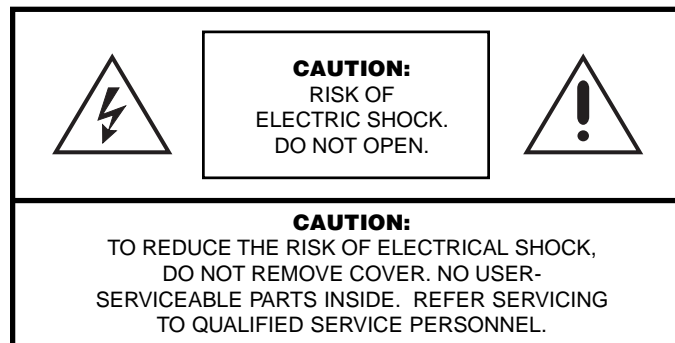

Please thoroughly familiarize yourself with the information in this manual prior to installation and operation.

2.0 DESCRIPTION

Pan/tilts in the PT1280P Series are heavy duty pan/tilts capable of handling loads up to 100 lb. They feature rugged high torque AC motors with adjustable worm gear final drives to insure long operational life, as well as drift free operation.

The PT1280 Series pan/tilts are capable of auto/random scan operation with the addition of the Pelco solid-state auto/random scan joystick control. No additional conductors, micro switches or relays are required for auto/scan operation.

These pan/tilts are factory pre-wired for feed through of all control functions: pan/tilt, motorized zoom lenses, camera power (24 VAC), enclosure accessories and video. All connections are made at the input connector, eliminating the need for wiring harnesses in the field. This feature greatly reduces installation time, while increasing the reliability and serviceability of the system.

The PT1280SL has the added feature of 360° pan rotation.

2.1 MODELS

PT1280P	Heavy duty indoor/outdoor pan/tilt, 120 VAC
PT1208P/HB	Same as PT1280P except supplied with spot heaters in base, blanket heater in cover, 230 watts total. 120 VAC, 50/60 Hz
PT1280P/PP	Same as PT1280P except with presets
PT1280SL	Heavy duty indoor/outdoor pan/tilt with SL option (360° pan rotation)
PT1280SL/PP	Same as PT1280SL except with presets

2.2 OPTIONS

FG/1250P	High speed gears: 12°/sec pan, 6°/sec tilt. Reduces load to 50 lb (22.68 kg)
FGP/1250P	High speed gearing for pan: 12°/sec
FGT/1250P	High speed gearing for tilt: 6°/sec tilt. Reduces load to 50 lb (22.68 kg)
SEC	Sector scan modification allows pan/tilt to auto-scan and manually override in present sector (PT1280P)

2.3 CERTIFICATIONS

The products identified below have been tested and certified for agency compliance as noted.

Model	Agency Compliance Certification			
	CE	FCC	UL	CSA/cUL
PT1280P			X	
PT1280P/HB			X	
PT1280P/PP			X	
PT1280SL			X	
PT1280SL/PP			X	

Applicable CE, FCC, UL, and CSA/CUL directives/standards:

- UL Standard 2044

Additional applicable standards:

- NEMA Type 3R
- IP 32

3.0 INSTALLATION



CAUTION: Pan/tilts in the PT1280P Series are designed for upright or inverted operation and should never be mounted horizontally.

NOTE: When mounting the pan/tilt outdoors in the inverted position (base up), RTV silicone sealant, such as Dow Corning Type 732 or equivalent, should be applied to the areas indicated in Figure 1.

Pan/tilts in the PT1280P Series are designed to mount onto a horizontal surface in the upright or inverted position.

In order to ensure proper wiring and system operation of all components, it is recommended that you test the pan/tilt and the associated control equipment in your facility before field installation. Refer to Sections 3.3 through 3.5.

3.1 MOUNTING

Attach the pan/tilt unit to a mount, following the instructions that accompany the mount. To ensure maximum pan travel, mount the pan/tilt so that the fixed limit stop is directly opposite the center of the intended viewing area.

Make sure the mounting surface and the mounting method is strong enough to support four times the combined weight of the pan/tilt, enclosure, camera and lens. The pan/tilt unit weighs 54 pounds (24.49 kg). Refer to the manuals for your enclosure, camera, and lens for the weights of those units. The weight of the enclosure, camera, and lens must not exceed 100 pounds (45.4 kg).

3.2 CAMERA/ENCLOSURE MOUNTING

Attach the enclosure, camera and lens to the pan/tilt unit with 1/4-20 hardware (not supplied). The enclosure, camera and lens must be correctly mounted and balanced on the tilt table for proper operation.

3.3 WIRING

Cable distances for pan and tilt motors should not exceed the distances specified in Table A. Cable fabrication must be in accordance with Section 3.3.1, Mating Connector Assembly. The following are some recommended common installation practices.

1. Always use jacketed stranded multi-conductor interconnecting cable between the control and the pan/tilt unit, with additional conductors than needed for future servicing and or additions.
2. Always use color-coded conductors for ease of wiring and to identify functions at a later date.
3. Keep a wiring diagram with the system for later use and reference the upright or inverted position.

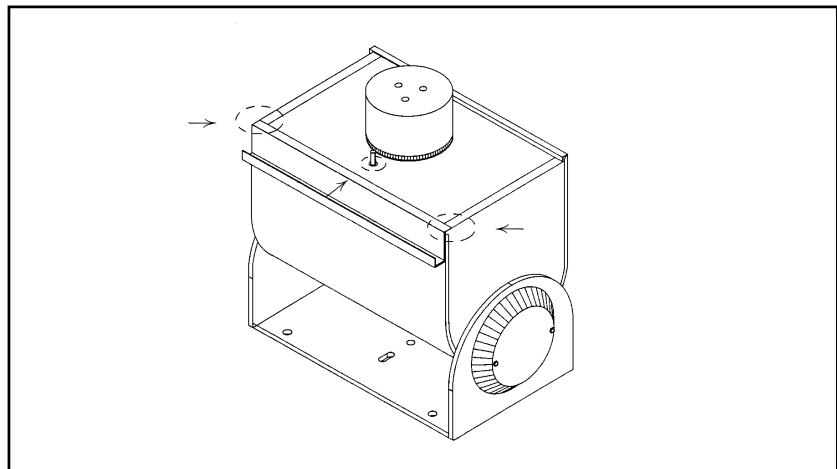

Figure 1 . Sealant Locations

Table A. Maximum Cable Distances

	Maximum Distance	
	6 Conductors	7 Conductors*
20 AWG	489 ft (149 m)	978 ft (298 m)
18 AWG	778 ft (237 m)	1,556 ft (474 m)
16 AWG	1,235 ft (376 m)	2,470 ft (752 m)

*Using 2-wire motor common

Conductors are for up, down, left, and right functions, motor common, and ground.

Cable distances are for both motors running and assuming a 10% voltage drop in the cable.

Six-conductor cable, single common conductor is recommended. Distances are approximate maximum recommended under the following conditions:

- Simultaneous pan/tilt activation
- Minimum 103.5 volts at pan/tilt

Operating distance may be extended by using an RB115 remote relay box. Refer to Table B for extended cable distances.

Table B. Recommended Cable Distances Using RB115 Relay Box

Wire Size (Awg)	Maximum Distance (feet) "A"	Maximum Distance (feet) "B"
20	5,800 (1,768 m)	489 (149 m)
18	8,250 (2,515 m)	778 (237 m)
16	13,000 (3,962 m)	1,235 (376 m)

3.3.1 Mating Connector Assembly

NOTE: Contacts cannot be removed from the connector without the use of the appropriate AMP extraction tool (ZT305183 for the 16-pin connector or ZT91067-2 for the 28-pin connector), which is available from Pelco.

NOTE: When a pan/tilt is mounted in the inverted position, the LEFT/RIGHT and UP/DOWN functions are reversed during operation. To correct this problem, reverse the LEFT/RIGHT functions in the control cable (pins 3 and 7) at the pan/tilt or control and the UP/DOWN functions (pins 5 and 6) at the pan/tilt or control.

To assemble the mating connector, refer to Figure 2 and perform the following steps.

The instructions that follow apply to all AMP style connectors regardless of pin size or pin number.

1. Slide the connector clamp assembly over the conductor cable. If the diameter of the conductor cable is such that the rubber boot will slide over it easily, slide the rubber boot onto the conductor cable at this time. If not, discard the rubber boot.
2. Refer to Detail A in Figure 2. Prepare the wires from the conductor cable as follows:
 - a. Strip at least 1-inch (2.54 cm) from the cable jacket to expose the wires. You may need to strip more from the cable jacket if you have more wires.
 - b. Strip 1/8-inch (0.125 cm) from each wire.
 - c. Using an AMP style crimper, crimp the wires and their insulation to the connector pins.
3. Slide the connector pins into the appropriate holes in the connector body until they snap into place. Refer to detail B in Figure 2 and to Figures 3-6 for correct pin arrangement, depending on model and options.
4. Push the connector clamp assembly (with boot, if used) toward the connector body. Screw the clamp assembly onto the connector body, being careful not to disturb the wires.
5. To complete the assembly, attach the appropriate clamp with the screws provided and tighten.

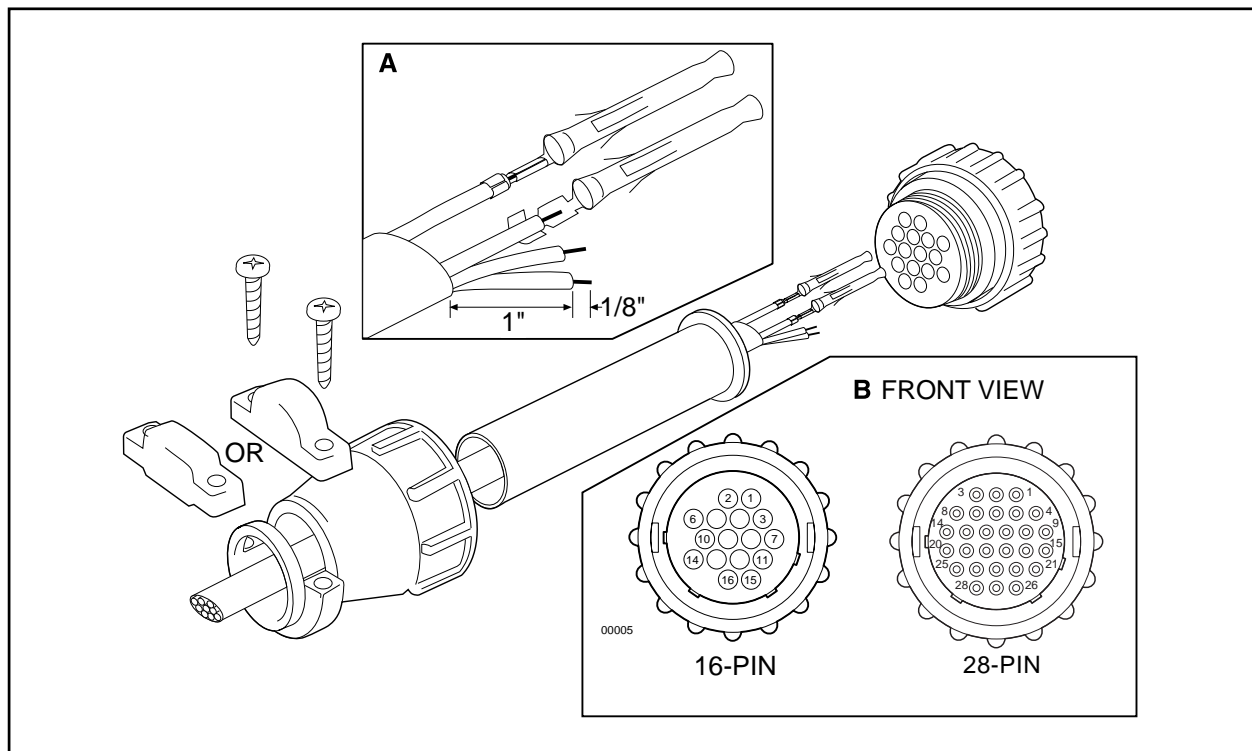

Figure 2. Connector Assembly

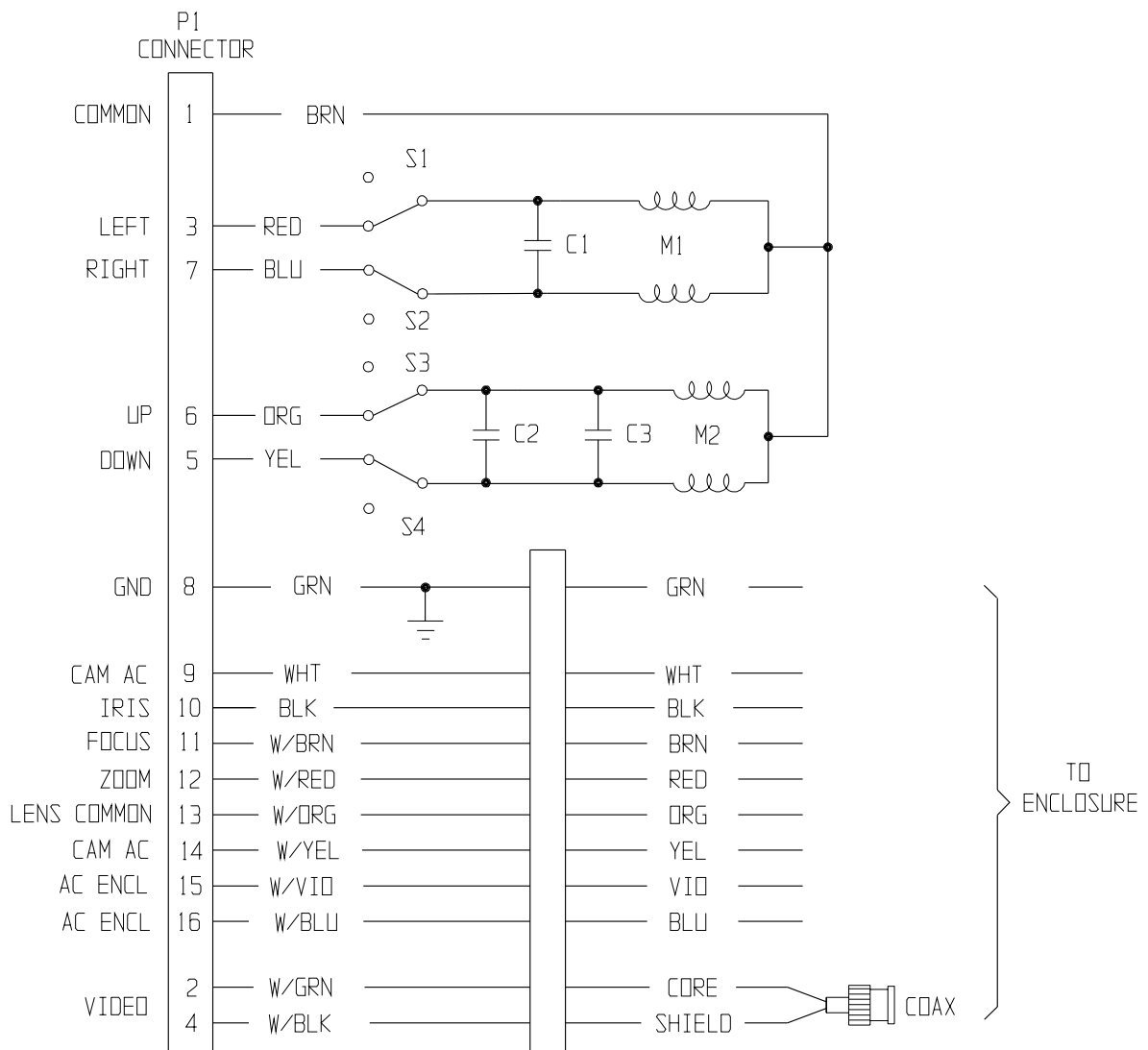
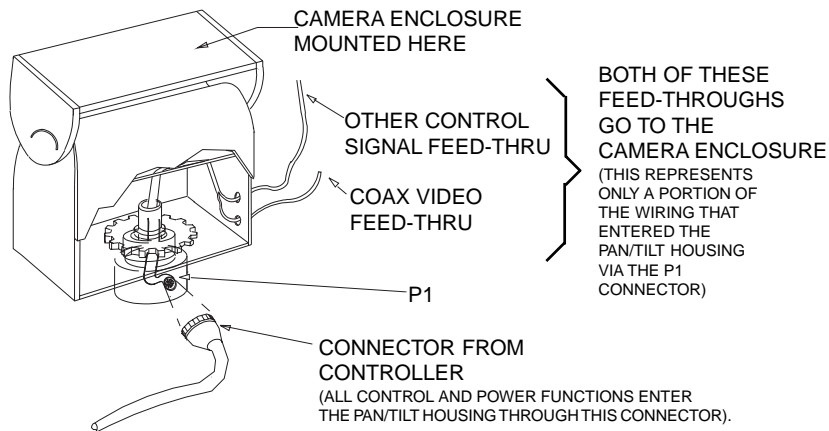

Figure 3. PT1280P/PT1280SL Wiring Diagram

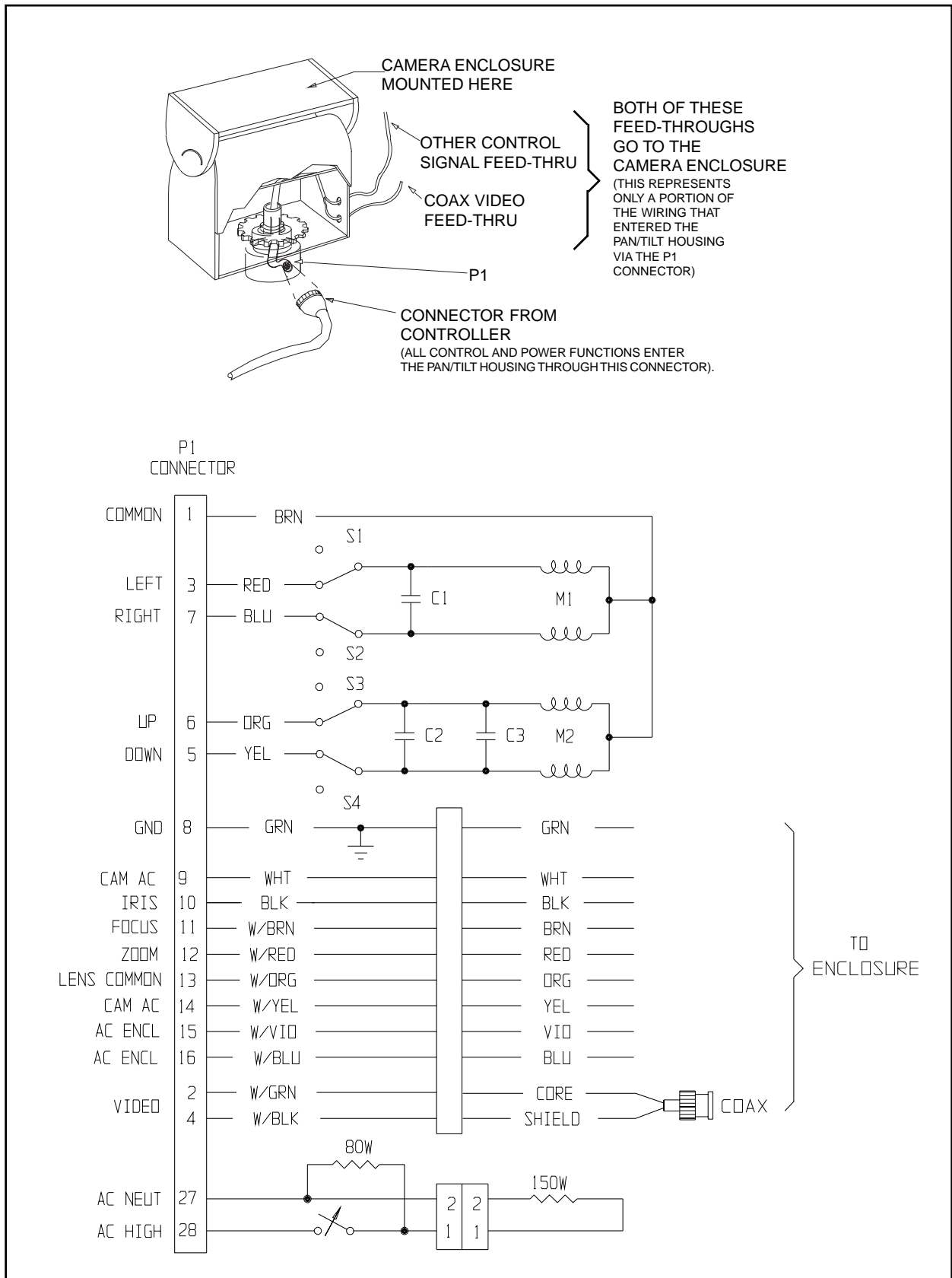

Figure 4. PT1280P/HB Wiring Diagram

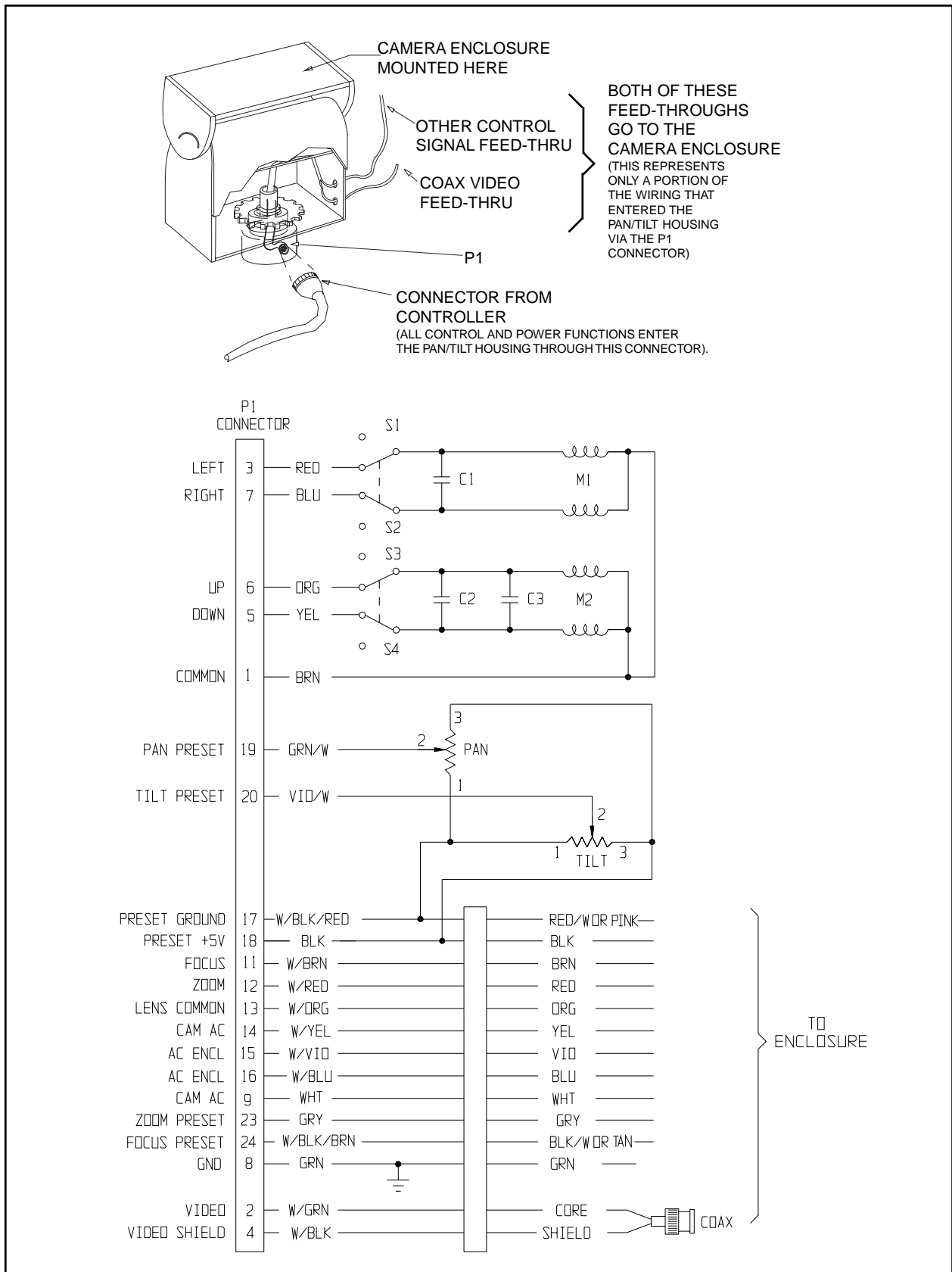

Figure 5. PT1280P/PP Wiring Diagram

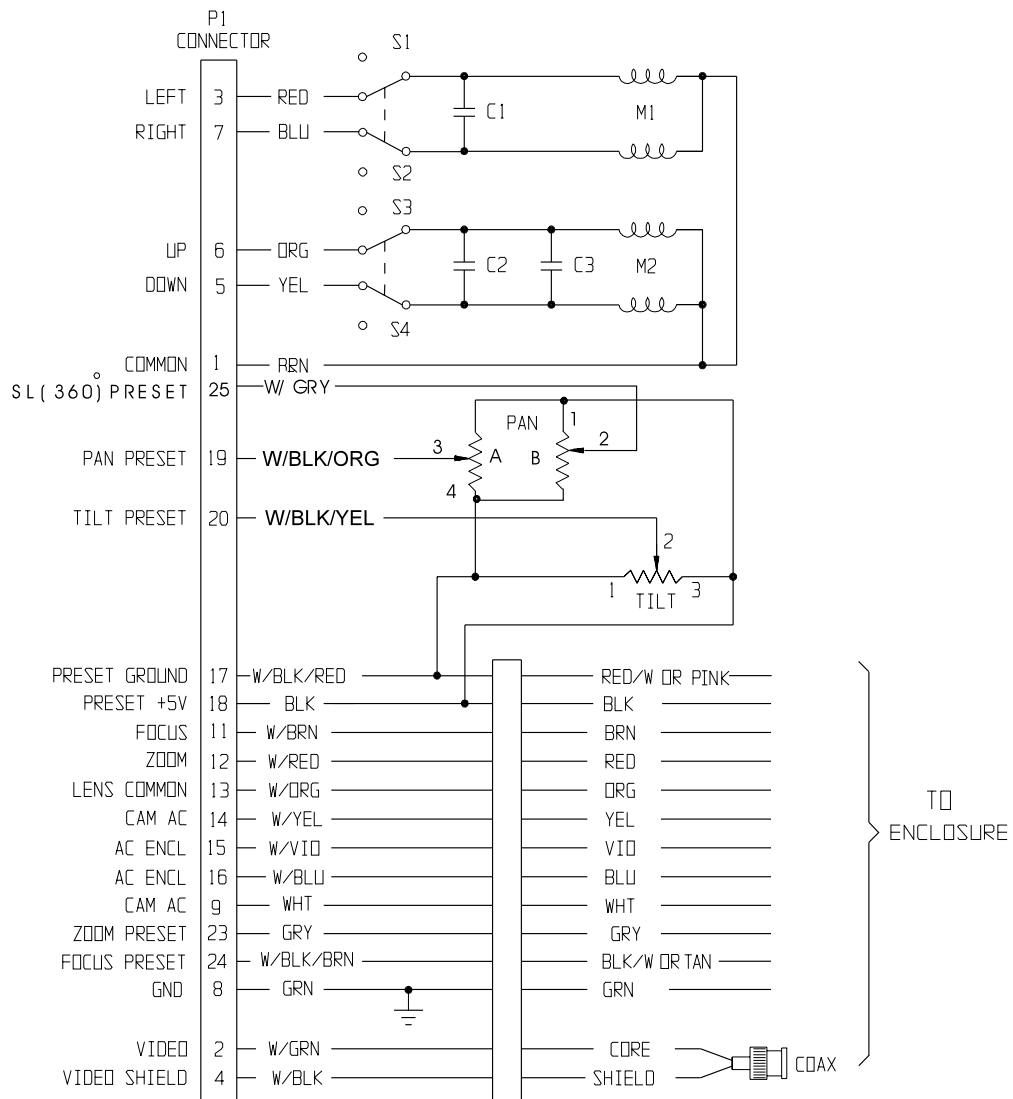
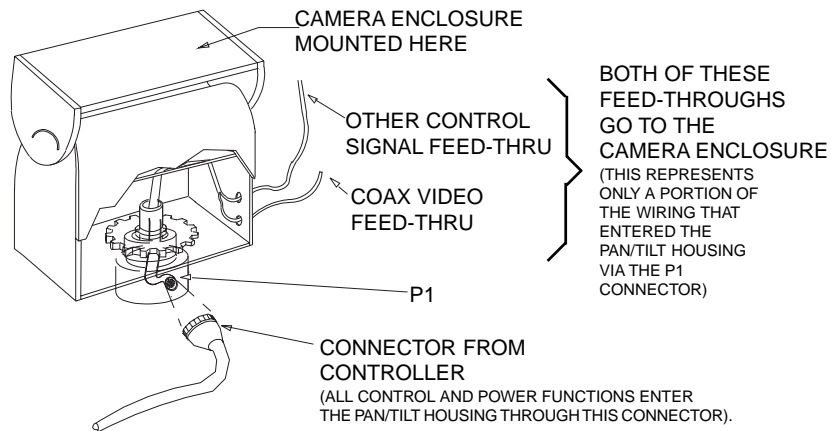

Figure 6. PT1280SL/PP Wiring Diagram

3.4 LIMIT STOP ADJUSTMENTS



WARNING: Do not operate the pan/tilt without limit stops.

Do not attempt to adjust the limit stops while the unit is operating. Personal injury or damage to the unit may result.

Do not remove or reposition the fixed limit stop on the pan/tilt. **DAMAGE WILL OCCUR.**

NOTE: The PT1280SL and the PT1280SL/PP do not have pan limit stops. Disregard steps 1-5.

To set pan/tilt limit stops, perform the following steps. Refer to Figure 7.

1. Loosen the pan limit stops.
2. Turn the control unit on. Pan the unit to the right until the desired right pan limit is reached.
3. Move the right pan limit stop until it touches the pan limit switch actuator. Move the stop a slight distance further against the actuator until it clicks to indicate the opening of the limit switch. Lock the stop in place.
4. Pan the unit to the desired left position. Adjust the left pan limit stop as described in step 3.
5. Pan left and right to both limit stops and check for exact positioning. Tighten both stops securely.
6. Turn on the control if you are starting at this step. Loosen the tilt limit stop screws and tilt the table, using the joystick, to the desired up position.
7. Move the up limit stop until it touches the tilt limit switch actuator and clicks. Lock the stop in place.
8. Tilt the table to the desired down position and set the stop in the same manner.
9. Tilt the table up and down and check for exact positioning. Tighten both stops securely.

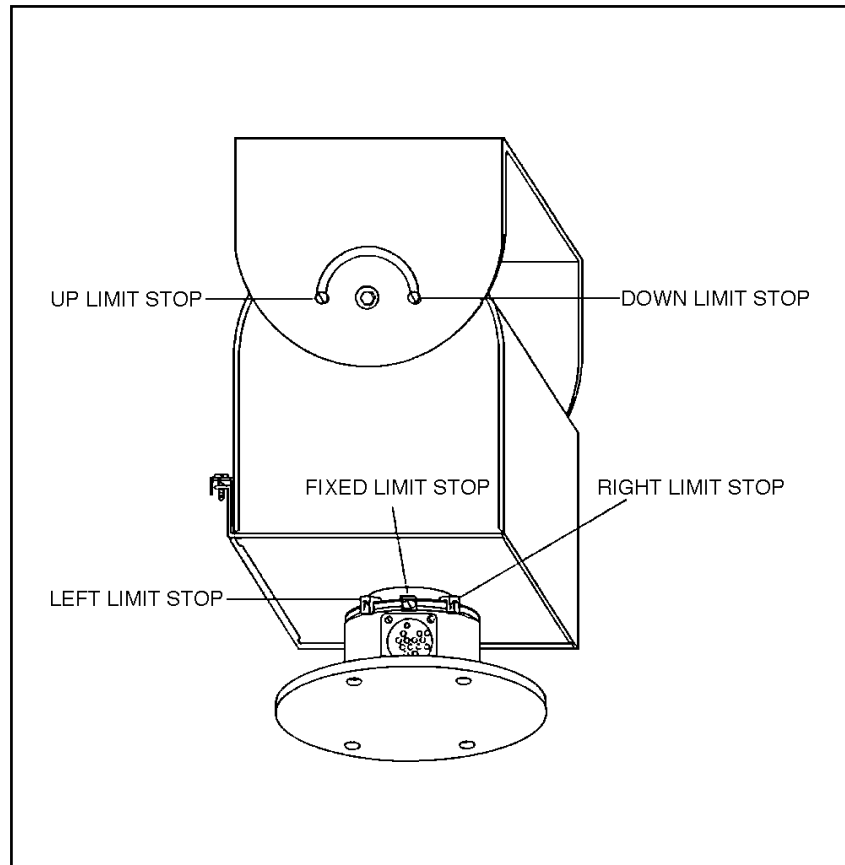

Figure 7. Limit Stops

4.0 OPERATION

Refer to the manual for your control equipment for operating the pan/tilt.

5.0 TROUBLESHOOTING

Some common problems encountered with pan/tilt systems include miswiring, overloading, and not using the units for the correct application. If the pan/tilt unit fails to operate, do the following:

1. Check the fuse in the control unit. If the fuse is bad, replace it.
2. If the fuse blows after replacing it, check the control cable between the control unit and the pan/tilt for shorts, high resistance, or opens.
3. If the control cable is good, reconnect it to the control unit but not to the pan/tilt. Replace the fuse and operate the control unit. If the fuse blows again, the fault is in the control.

Refer to Figure 3-6 for the following steps.

4. If the control unit is good, check the wiring harness in the pan/tilt for shorts.
5. If the wiring harness is good, check the motor starting capacitors.
6. If the starting capacitors are good, check the motors for opens and shorts. There should be low resistance between the windings.
7. Check the limit switches for opens and shorts.

5.1 SERVICE MANUAL

If you need to service your unit, obtain a service manual in one of the following ways:

- Go to Pelco's web site at <http://www.pelco.com> and find service manual C373SM.
- Contact Pelco's Literature Department and request service manual C373SM.

6.0 MAINTENANCE

Inspect the pan/tilt unit every six months to ensure trouble-free operation and an extended product life. Harsh environments and/or continuous motion applications may require more frequent maintenance.

Please read all of the instructions that follow before servicing the pan/tilt.

To begin, remove the three screws on the front of the pan/tilt housing and lift the cover to gain access to the pan and tilt motor assemblies.

6.1 TIGHTENING DRIVE CHAINS

Check the pan and tilt drive chains for tension. A movement of 1/32 of an inch to 3/32 of an inch in the chains is acceptable. If the movement of a chain exceeds 3/32 of an inch, adjust the chain as follows:

1. Loosen the screws securing the motor to the mounting frame.
2. Pry on the motor to apply tension to the chain. Do not over-tension the drive chain.
3. Keep tension on the chain while tightening the screws.

6.2 CHAIN DRIVE LUBRICATION

Sprockets, chains, and gears should be well greased. If necessary, lubricate the pan and tilt gears, sprockets, and chains as follows with a high-quality grease capable of withstanding temperatures from -50° to 170°F (-46° to 77°C). Do the following:

1. Liberally apply grease to the pan and tilt gears, chains, and sprockets (refer to Figure 8).
2. Operate the pan and tilt motors to spread the grease across the parts.
3. Apply additional grease if necessary.
4. Reinstall the cover. If the pan/tilt is installed outdoors in an inverted position, apply RTV silicone sealant as shown in Figure 1.

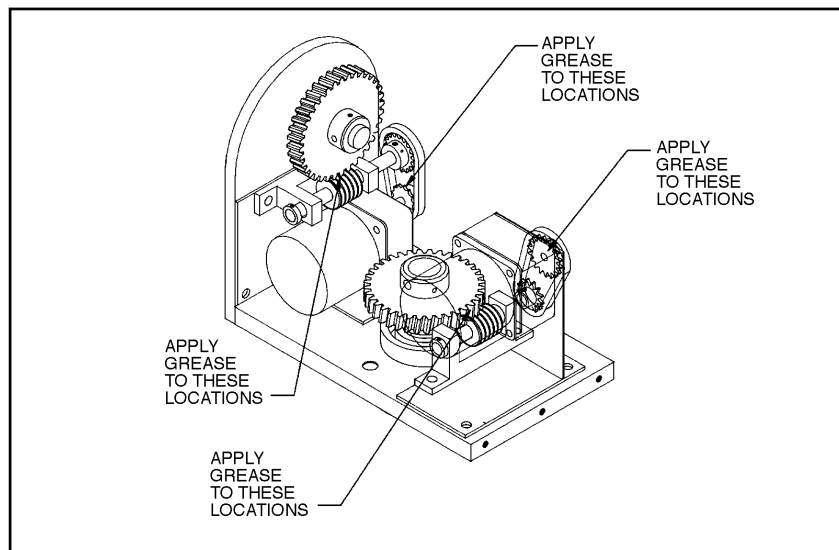

Figure 8. Servicing the Pan/Tilt

6.3 MOTOR BRAKE REPLACEMENT



WARNING: *The knife-blade included in the brake kit is very sharp. It should be handled carefully and disposed of properly after use.*

To order replacement motor brakes, specify part number 1250BRAKE. The kit consists of four springs, four Teflon pads, two screws, and a small knife-blade for removing the old brake pads.

1. Remove the large rectangular heat sink from the back of the pan motor. Remove the four springs. Do not disturb the silicone heat sink compound. It ensures the transfer of heat to the heat sink and **MUST** be present when the heat sink is replaced.
2. Use the knife blade to remove the worn pads, as follows:
 - a. Insert the knife blade into the opening and press firmly into the brake pad.
 - b. Before trying to remove the brake pad, twist the knife-blade. This will loosen the worn pad and make removal easier.
 - c. Gently twist the blade as you pull the worn pad out.
3. Insert the four new brake pads and four springs. Replace the heat sink using the new screws.

Reinstall the cover. If your pan/tilt is installed in an inverted position, apply RTV silicone sealant to the areas circled in Figure 1.

7.0 SPECIFICATIONS

MECHANICAL

Pan:	Movement in horizontal plane
PT1280P:	0-355°
PT1280SL:	360° pan rotation
Speed:	6°/sec ±1° (No load condition)
Torque:	50 ft/lb with specified voltage
Tilt:	±90° movement in vertical plane
Speed:	3°/sec ± .5° (No load condition)
Maximum Load:	100 lb (45.4 kg) at 5 inches (12.7 cm) from tilt table surface to center of gravity
Gearing:	Adjustable worm gear final drive to prevent drift and minimize backlash
Bearings:	
Pan:	Heavy duty ball bearings
Tilt:	Oilite bronze bushing
Braking:	Mechanical

ELECTRICAL

Input Voltage:	120 VAC, 60 Hz required for pan/tilt									
Power Requirements:										
	<table><thead><tr><th></th><th><u>Pan</u></th><th><u>Tilt</u></th></tr></thead><tbody><tr><td>Running:</td><td>.48 amp (57.5 vA)</td><td>.48 amp (57.5 vA)</td></tr><tr><td>Starting:</td><td>.60 amp (72.5 vA)</td><td>.60 amp (72.5 vA)</td></tr></tbody></table>		<u>Pan</u>	<u>Tilt</u>	Running:	.48 amp (57.5 vA)	.48 amp (57.5 vA)	Starting:	.60 amp (72.5 vA)	.60 amp (72.5 vA)
	<u>Pan</u>	<u>Tilt</u>								
Running:	.48 amp (57.5 vA)	.48 amp (57.5 vA)								
Starting:	.60 amp (72.5 vA)	.60 amp (72.5 vA)								
Maximum Current:	2 amps per conductor (SL models only)									
Connectors:	Amp CPC type (mate supplied)									
Motors:	Two-phase induction type, continuous duty, instantaneous reversing									
Limit Switches										
Pan:	5 amp, external adjustment									
Tilt:	5 amp , external adjustment									
Conductors:	6 or 7, unshielded. (Functions: left, right, up, down, motor common, safety ground.) No additional conductors for auto scan when used with solid-state control. PP option requires additional 4 conductors.									

GENERAL

Dimensions: See Figure 9

Construction: Aluminum casting and plate

Finish: Textured semi-gloss beige enamel

Environment: Completely weatherproof for indoor/outdoor operation

Temperature: -10° to 120°F (-23.33° to 48.89°C)

Weight: Unit Shipping
 54 lb (24.49 kg) 58 lb (26.30 kg)

(Design and product specifications subject to change without notice.)

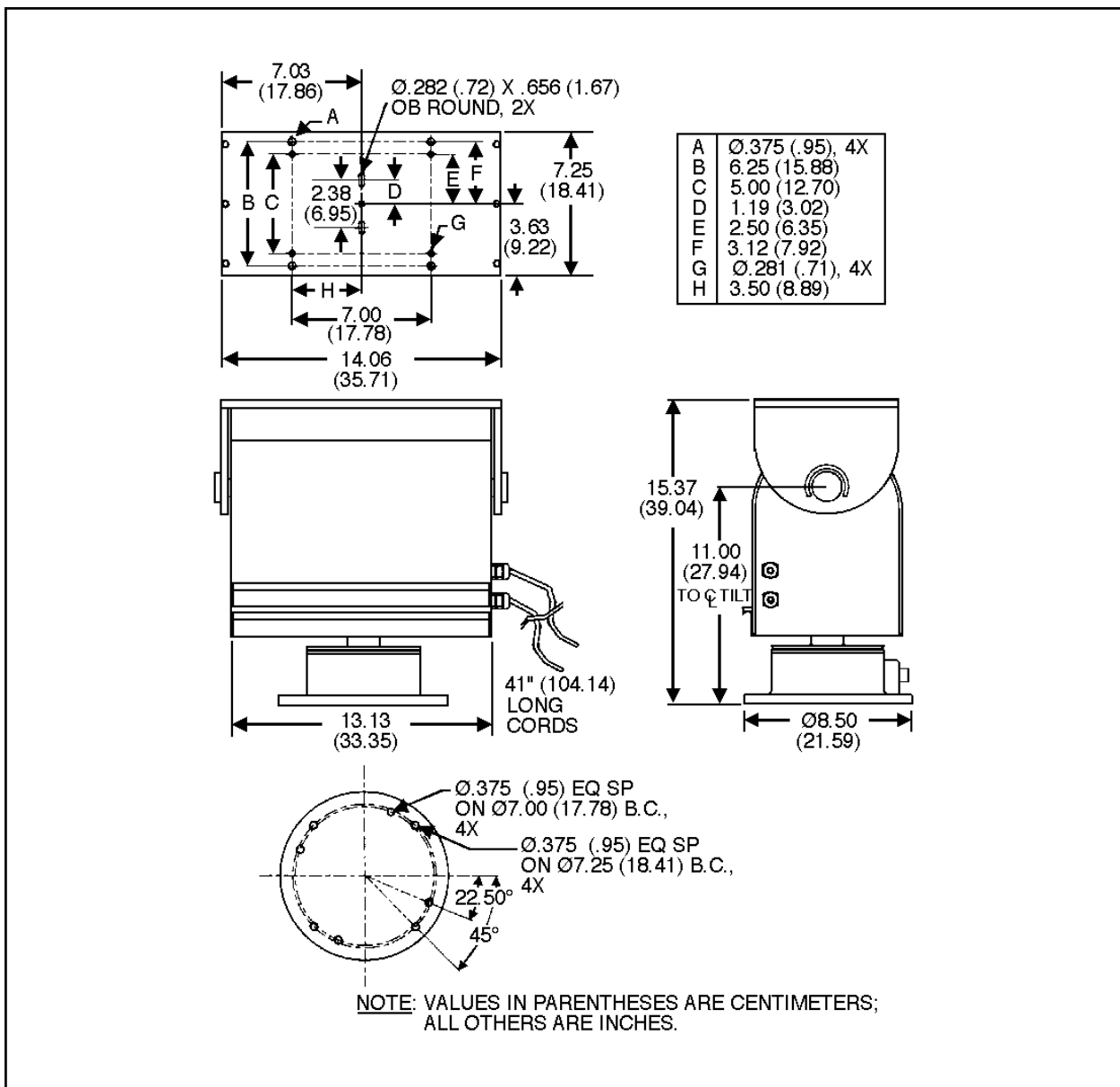

Figure 9. Dimension Drawing

8.0 WARRANTY AND RETURN INFORMATION

WARRANTY

Pelco will repair or replace, without charge, any merchandise proved defective in material or workmanship for a period of one year after the date of shipment.

Exceptions to this warranty are as noted below:

- Five years on FT/FR8000 Series fiber optic products.
- Three years on Genex® Series products (multiplexers, server, and keyboard).
- Three years on Camclosure® and fixed camera models, except the CC3701H-2, CC3701H-2X, CC3751H-2, CC3651H-2X, MC3651H-2, and CC3651H-2X camera models, which have a five-year warranty.
- Two years on standard motorized or fixed focal length lenses.
- Two years on Legacy®, CM6700/CM6800/CM9700 Series matrix, and DF5/DF8 Series fixed dome products.
- Two years on Spectra®, Esprit®, ExSite™, and PS20 Scanners, including when used in continuous motion applications.
- Two years on Esprit® and WW5700 Series window wiper (excluding wiper blades).
- Eighteen months on DX Series digital video recorders, NVR300 Series network video recorders, and Endura™ Series distributed network-based video products. months on DX Series digital video recorders, NVR300 Series network video recorders, Endura™ Series distributed network-based video products, and TW3000 Series twisted pair transmission products.
- One year (except video heads) on video cassette recorders (VCRs). Video heads will be covered for a period of six months.
- Six months on all pan and tilts, scanners or preset lenses used in continuous motion applications (that is, preset scan, tour and auto scan modes).

Pelco will warrant all replacement parts and repairs for 90 days from the date of Pelco shipment. All goods requiring warranty repair shall be sent freight prepaid to Pelco, Clovis, California. Repairs made necessary by reason of misuse, alteration, normal wear, or accident are not covered under this warranty.

Pelco assumes no risk and shall be subject to no liability for damages or loss resulting from the specific use or application made of the Products. Pelco's liability for any claim, whether based on breach of contract, negligence, infringement of any rights of any party or product liability, relating to the Products shall not exceed the price paid by the Dealer to Pelco for such Products. In no event will Pelco be liable for any special, incidental or consequential damages (including loss of use, loss of profit and claims of third parties) however caused, whether by the negligence of Pelco or otherwise.

The above warranty provides the Dealer with specific legal rights. The Dealer may also have additional rights, which are subject to variation from state to state.

If a warranty repair is required, the Dealer must contact Pelco at (800) 289-9100 or (559) 292-1981 to obtain a Repair Authorization number (RA), and provide the following information:

1. Model and serial number
2. Date of shipment, P.O. number, Sales Order number, or Pelco invoice number
3. Details of the defect or problem

If there is a dispute regarding the warranty of a product which does not fall under the warranty conditions stated above, please include a written explanation with the product when returned.

Method of return shipment shall be the same or equal to the method by which the item was received by Pelco.

RETURNS

In order to expedite parts returned to the factory for repair or credit, please call the factory at (800) 289-9100 or (559) 292-1981 to obtain an authorization number (CA number if returned for credit, and RA number if returned for repair).

All merchandise returned for credit may be subject to a 20% restocking and refurbishing charge.

Goods returned for repair or credit should be clearly identified with the assigned CA or RA number and freight should be prepaid. Ship to the appropriate address below.

If you are located within the continental U.S., Alaska, Hawaii or Puerto Rico, send goods to:

Service Department
Pelco
3500 Pelco Way
Clovis, CA 93612-5699

If you are located outside the continental U.S., Alaska, Hawaii or Puerto Rico and are instructed to return goods to the USA, you may do one of the following:

If the goods are to be sent by a COURIER SERVICE, send the goods to:

Pelco
3500 Pelco Way
Clovis, CA 93612-5699 USA

If the goods are to be sent by a FREIGHT FORWARDER, send the goods to:

Pelco c/o Expeditors
473 Eccles Avenue
South San Francisco, CA 94080 USA
Phone: 650-737-1700
Fax: 650-737-0933

Free Manuals Download Website

<http://myh66.com>

<http://usermanuals.us>

<http://www.somanuals.com>

<http://www.4manuals.cc>

<http://www.manual-lib.com>

<http://www.404manual.com>

<http://www.luxmanual.com>

<http://aubethermostatmanual.com>

Golf course search by state

<http://golfingnear.com>

Email search by domain

<http://emailbydomain.com>

Auto manuals search

<http://auto.somanuals.com>

TV manuals search

<http://tv.somanuals.com>