



Public View Monitor



C2943M (1/08)

Contents

Important Safety Instructions	5
Regulatory Notices	6
Description	7
Models	7
Speakers	7
Package Contents	7
Installation	8
Mounting	8
Wiring	8
Rear Panel Connectors	9
Operation	10
Front and Side Panel Controls	10
Installing Remote Control Batteries	11
Remote Control Functions	12
OSD Function	13
Input Source Display	13
Main Menu	14
Menu Display	15
Menu Field Definitions	16
Media Control	18
Replacing the Camera	20
Camera Removal	20
DIP Switch Settings	20
Camera Installation and Camera Adjustment	21
Specifications	23

List of Illustrations

1	Parts List	7
2	Rear Panel Connectors	9
3	Front and Side Panel Controls	10
4	Battery Installation	11
5	Remote Control Functions	12
6	Input Source Display Screen	13
7	Main Menu	14
8	Menu Tree	15
9	Media Type Selection Screen	18
10	Slide Show Screen	18
11	Media Menu Tree	19
12	Access Door	20
13	DIP Switches	20
14	Adjusting the Camera	22

List of Tables

A	Recommended Wiring Distances	8
---	------------------------------	---

Important Safety Instructions

1. Read these instructions.
2. Keep these instructions.
3. Heed all warnings.
4. Follow all instructions.
5. Do not use this apparatus near water.
6. Clean only with dry cloth.
7. Do not block any ventilation openings. Install in accordance with the manufacturer's instructions.
8. Do not install near any heat sources such as radiators, heat registers, stoves, or other apparatus (including amplifiers) that produce heat.
9. Do not defeat the safety purpose of the polarized or grounding-type plug. A polarized plug has two blades with one blade wider than the other. A grounding plug has two blades and a third grounding prong. The wide blade or the third prong are provided for your safety. If the provided plug does not fit into your outlet, consult an electrician for replacement of the obsolete outlet.
10. Protect the power cord from being walked on or pinched particularly at plugs, convenience receptacles, and the points where they exit from the apparatus.
11. Only use attachments/accessories specified by the manufacturer.
12. Only use with the cart, stand, tripod, bracket, or table specified by the manufacturer, or sold with the apparatus. When a cart is used, use caution when moving the cart/apparatus combination to avoid injury from tip-over.
13. Refer all servicing to qualified service personnel. Servicing is required when the apparatus has been damaged in any way, such as power-supply cord or plug is damaged, liquid has been spilled or objects have fallen into the apparatus, the apparatus has been exposed to rain or moisture, does not operate normally, or has been dropped.
14. Unplug the apparatus during lightning storms or when unused for long periods of time.
15. Apparatus shall not be exposed to dripping or splashing and no objects filled with liquids, such as vases shall be placed on the apparatus.
16. **WARNING:** To reduce the risk of fire or electric shock, do not expose this apparatus to rain or moisture.
17. Installation should be done only by qualified personnel and conform to all local codes.
18. Unless this unit is specifically marked as NEMA Type 3, 3R, 3S, 4, 4X, 6, or 6P enclosure, it is designed for indoor use only and it must not be installed where exposed to rain and moisture.
19. Only use installation methods and materials capable of supporting four times the maximum specified load.
20. Only use replacement parts recommended by Pelco.
21. Avoid touching the screen directly with your fingers as the oils from your skin may be difficult to remove from the LCD.
22. Do not apply direct pressure on the screen.
23. Keep the monitor in a dust-free environment and away from strong electromagnetic fields.
24. Do not use attachments, such as mounts, that are not recommended by Pelco. They may be hazardous.
25. Do not place the monitor on an unstable stand, bracket, or mount. The unit may fall, causing serious damage to the unit or injury to a person. Only use mounts recommended by Pelco.
26. A CCC-approved power cord must be used to power this equipment when used in China.
27. A still image displayed too long may cause permanent damage to the LCD panel. Watching the LCD in 4:3 format for a long time may leave traces of borders displayed on the left, right and center of the screen caused by the difference of light emission on the screen. Using a camera or a system may cause a similar effect to the screen. Damages caused by this effect are not covered by the warranty.

The product and/or manual may bear the following marks:



This symbol indicates that dangerous voltage constituting a risk of electric shock is present within this unit.



This symbol indicates that there are important operating and maintenance instructions in the literature accompanying this unit

CAUTION:
RISK OF ELECTRIC SHOCK.
DO NOT OPEN.

Regulatory Notices

This device complies with Part 15 of the FCC Rules. Operation is subject to the following two conditions: (1) this device may not cause harmful interference, and (2) this device must accept any interference received, including interference that may cause undesired operation.

RADIO AND TELEVISION INTERFERENCE

This equipment has been tested and found to comply with the limits of a Class A digital device, pursuant to Part 15 of the FCC Rules. These limits are designed to provide reasonable protection against harmful interference when the equipment is operated in a commercial environment. This equipment generates, uses, and can radiate radio frequency energy and, if not installed and used in accordance with the instruction manual, may cause harmful interference to radio communications. Operation of this equipment in a residential area is likely to cause harmful interference in which case the user will be required to correct the interference at his own expense.

Changes and Modifications not expressly approved by the manufacturer or registrant of this equipment can void your authority to operate this equipment under Federal Communications Commission's rules.

In order to maintain compliance with FCC regulations shielded cables must be used with this equipment. Operation with non-approved equipment or unshielded cables is likely to result in interference to radio and television reception.

This Class A digital apparatus complies with Canadian ICES-003.

Cet appareil numérique de la classe A est conforme à la norme NMB-003 du Canada



WARNING: This product is sensitive to Electrostatic Discharge (ESD). To avoid ESD damage to this product, use ESD safe practices during installation. Before touching, adjusting or handling this product, correctly attach an ESD wrist strap to your wrist and appropriately discharge your body and tools. For more information about ESD control and safe handling practices of electronics, please refer to ANSI/ESD S20.20-1999 or contact the Electrostatic Discharge Association (www.esda.org).

Description

Public view monitors (PVM) are units that contain a built-in camera that is pointed in the direction the monitor faces. The camera's view is displayed on the same monitor so customers can see themselves. This feature makes the PVM ideal for commercial establishments because it creates interest, while discouraging theft.

The PVM also includes connections for additional camera inputs DVD players and inputs for media cards.

Some camera functions are controlled through menus; others are controlled through the DIP switches on the built-in camera located inside the monitor.

MODELS

PMP20B 20-inch (510 mm) LCD black monitor with wide dynamic range (WDR) camera

PMP20W 20-inch (510 mm) LCD white monitor with WDR camera

PMP26B 26-inch (660 mm) LCD black monitor with WDR camera

PMP26W 26-inch (660 mm) LCD white monitor with WDR camera

SPEAKERS

PVM models come with two internal speakers.

PACKAGE CONTENTS

- 1 20- or 26-inch LCD public view monitor (in black or white case) with WDR camera
- 1 Remote control unit
- 2 AAA batteries
- 1 Installation/Operation manual

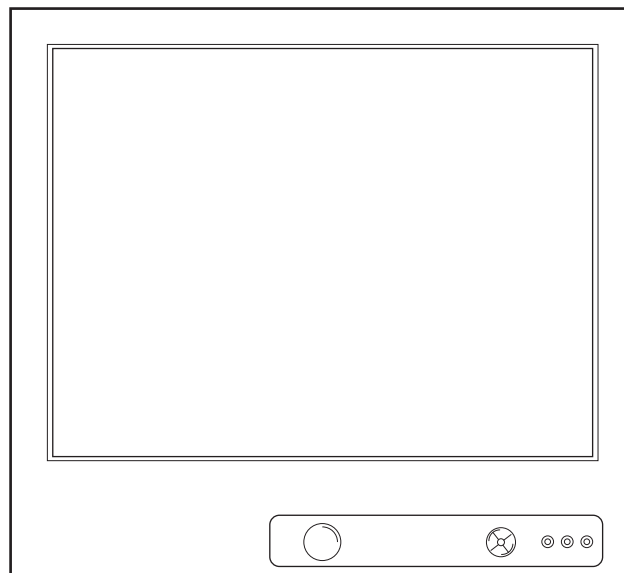

PUBLIC VIEW MONITOR



REMOTE CONTROL
1 EA.
AAA BATTERIES
2 EA.

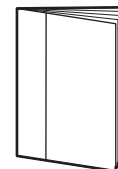

INSTALLATION/OPERATION MANUAL
1 EA.

Figure 1. Parts List

Installation

MOUNTING

The PVM accommodates mounts that adhere to the VESA® 100 x 100 standard.

For mounting from a ceiling, Pelco recommends using the PMCL-CM mount. This mount can be swiveled 360 degrees, and lets you tilt the monitor 35 degrees for the best viewing angle. This mount must be used with a pole to hang the monitor from a ceiling. The PMCL-CM can support a maximum load of 90 lb (40.8 kg).

For more information and instructions on mounting, refer to the PMCL-CM Monitor Mount Installation manual (C2226M).

For a list of additional mounts, refer to *Specifications* on page 23.

WIRING

1. On the back of the monitor, loosen the thumb screws and lower the access panel.
2. Attach the leads from the power supply (not supplied) to the left and right connectors, refer to callout 1 in Figure 2 on page 9. For more information about power supplies, refer to *Recommended Power Supplies* on page 25.

NOTE: Do not connect a ground to the center post.

3. Connect the camera output and any other devices using the connectors, refer to Figure 2 on page 9. Devices that can be connected include DVD players, time-lapse VCRs, and media cards.
4. When finished, secure the access panel.

Table A shows the recommended maximum wiring distances (transformer to load), and are calculated with a 10-percent voltage drop. (Ten percent is generally the maximum allowable voltage drop for AC-powered devices.)

NOTE: For the 26-inch PVM, the maximum VA requirement is 160.8; the maximum current draw is 6.7 A. For the 20-inch PVM, the maximum VA requirement is 96; the maximum current draw is 4.0 A.

Table A. Recommended Wiring Distances

Total VA Consumed	Wire Gauge					
	20 AWG (0.5 mm ²)	18 AWG (1.0 mm ²)	16 AWG (1.5 mm ²)	14 AWG (2.5 mm ²)	12 AWG (4.0 mm ²)	10 AWG (6.0 mm ²)
100	28 ft (8 m)	45 ft (13 m)	71 ft (21 m)	114 ft (34 m)	181 ft (55 m)	288 ft (87 m)
160	17 ft (5 m)	28 ft (8 m)	44 ft (13 m)	71 ft (21 m)	113 ft (34 m)	180 ft (54 m)

REAR PANEL CONNECTORS

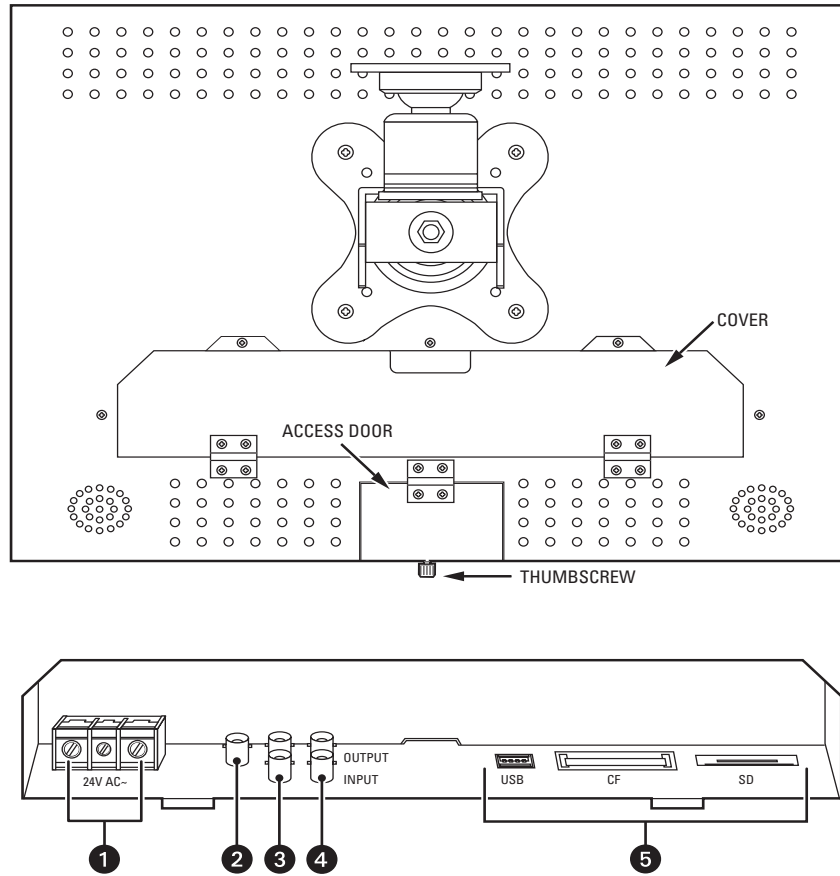

Figure 2. Rear Panel Connectors

- ❶ **24 V AC~:** The 24 volt AC power.

NOTE: The center post is not to be used.

- ❷ **Camera Out:** The internal camera's video output signal.

- ❸ **Video 2 (loop through):** The input connections from a camera or a DVD player. Video loops through the BNC video output.

- ❹ **Video 1 (loop through):** The input connections from a camera or a DVD player. Video loops through the BNC video output.

- ❺ **Media Input:** The three media input ports for loading slide files: one USB port for flash drives and two card ports (CF card or SD card).

NOTE: The USB media input port detects only USB flash memory, it cannot detect external USB devices, such as an external HDD.

Operation

FRONT AND SIDE PANEL CONTROLS

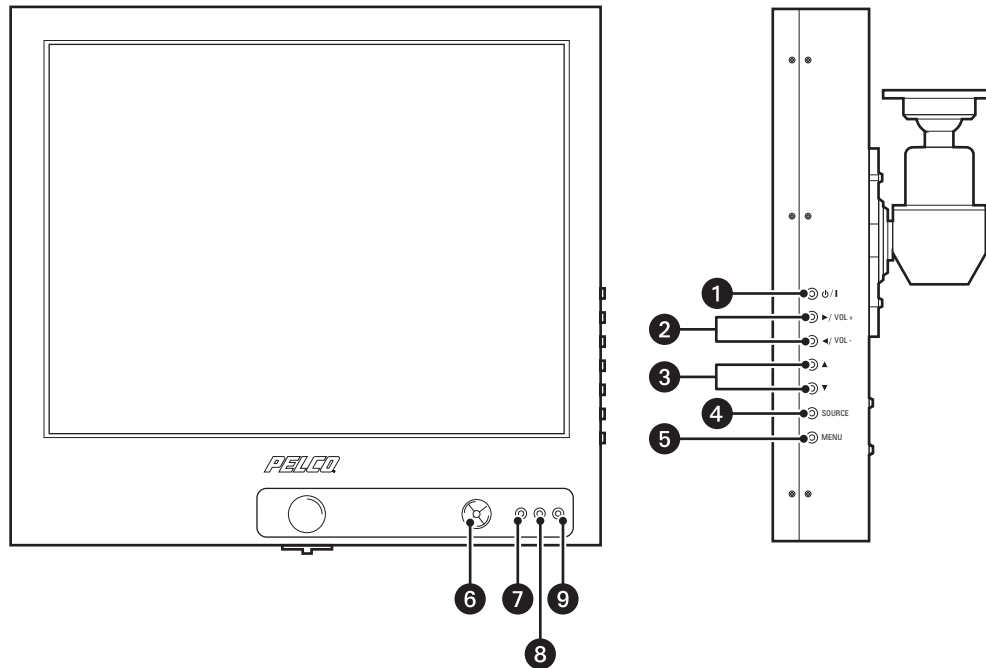

Figure 3. Front and Side Panel Controls

- ❶ **(Power):** Turns on/off the monitor.
- ❷ **▶ /VOL + and ◀ /VOL-:** Increases or decreases the volume. Also selects or adjusts items on the on-screen menu.
- ❸ **▲ and ▼:** Navigates through the on-screen menu.
- ❹ **SOURCE:** Selects and confirms the input source.
- ❺ **MENU:** Displays the main on-screen menu (monitor).
- ❻ **(PIR Sensor):** Motion detection sensor.
- ❼ **(CDS Sensor):** Brightness detection sensor.
- ❽ **(Remote Control Signal Receiver):** Receives a remote control signal.
- ❾ **(Power Indicator):** Indicates the power status. A red light indicates the power is off; a green light indicates the power is on.

INSTALLING REMOTE CONTROL BATTERIES

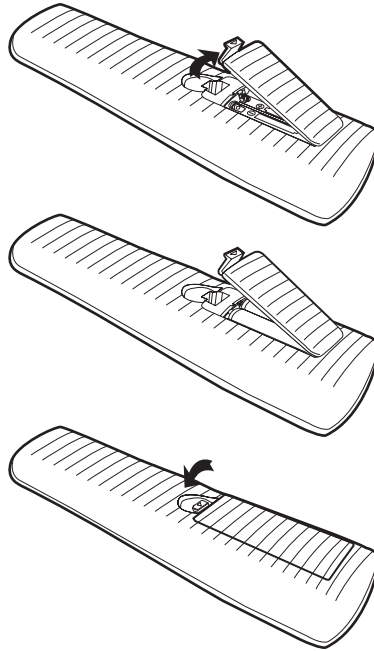

Figure 4. Battery Installation

1. Open and remove the back cover of the remote control.
2. Install two AAA size batteries (supplied). Match the plus (+) and minus (-) symbols on the batteries to the symbols on the battery compartment.
3. Close the battery cover. Make sure the lock snaps closed.

 **WARNINGS:**

- Dispose of batteries in a designated disposal area. Do not throw batteries into a fire.
- Do not mix battery types.
- Remove dead batteries immediately to prevent battery acid from leaking into the battery compartment.
- Remove the batteries if you do not intend to use the remote control for a long period of time.

REMOTE CONTROL FUNCTIONS

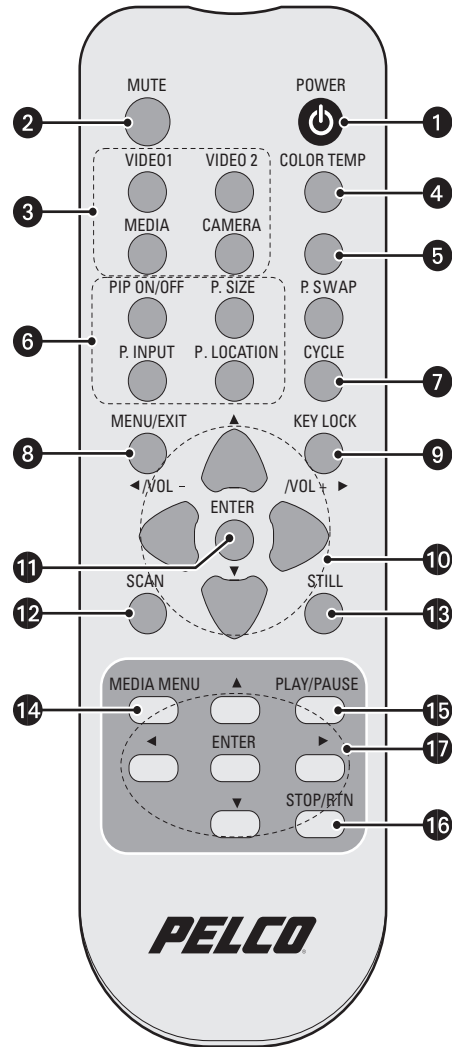

Figure 5. Remote Control Functions

- ❶ **POWER:** Turns on/off power to the monitor.
- ❷ **MUTE:** Temporarily silences the sound. To return the sound, press MUTE again, or VOL + or VOL -.
- ❸ **VIDEO1/VIDEO2/MEDIA/CAMERA:** Displays all the available input sources. Press the appropriate button to select the desired input source.
- ❹ **COLOR TEMP:** Adjusts the color temperature of the screen.
- ❺ Reserved for future use.
- ❻ **(PIP):** Controls the following picture-in-picture (PIP) features:
 - PIP ON/OFF:** Activates or deactivates PIP and picture-by-picture (PBP) modes.
 - P.SIZE:** Selects the size of the subpicture.
 - P.SWAP:** Swaps the main and subpicture.
 - P.INPUT:** Selects an input source for the subpicture.
 - P.LOCATION:** Selects a location for the subpicture.
- ❼ **CYCLE:** Cycles the input source:
 - In PIP or PBP, the subpicture is cycled.
 - In Full screen, the main picture is cycled.
 - You can define the cycle time and source in the menu.

- ⑧ **MENU/EXIT:** Displays or exits the on-screen menu.
- ⑨ **KEY LOCK:** Locks the buttons to prevent unauthorized operation of the equipment.
- ⑩ (◀ /VOL- and ▶ /VOL+, ▲, and ▼): Controls the cursor on the on-screen menu and adjusts the volume up or down.
- ⑪ **ENTER:** Confirms (store or enter) your choice in the on-screen menu.
- ⑫ **SCAN:** Changes the screen's scan mode (Under, Full, Over, 4:3). (The 4:3 mode applies only to the 26-inch model.)
- ⑬ **STILL:** Freezes the current picture.
- ⑭ **MEDIA MENU:** Displays or exits the media menu.
- ⑮ **PLAY/PAUSE:** Play and pause the slide show picture or video clip.
- ⑯ **STOP/RTN:** Stop the slide show, or return to the previous page or video clip.
- ⑰ (◀ / ▶ / ▲ / ▼ /): Controls the cursor on the media menu.

When viewing pictures, the left and right arrow buttons (◀ and ▶) select the previous or next picture. The up and down arrow buttons (▲ and ▼) rotate the picture.

However, with sound turned on, the up and down arrow buttons (▲ and ▼) increase or decrease the sound. The left and right arrow buttons (◀ and ▶) have no function.

OSD FUNCTION

INPUT SOURCE DISPLAY

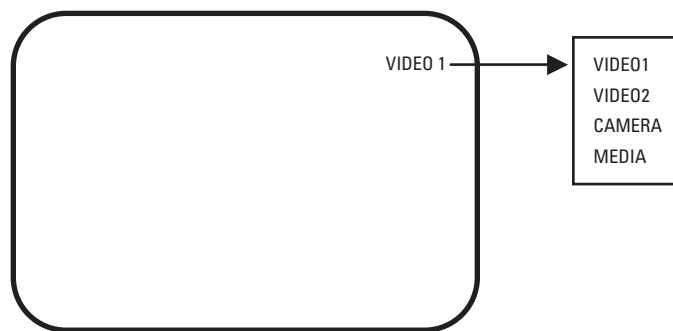

Figure 6. Input Source Display Screen

The input source is displayed in the upper-right corner, where it can be changed. It can be changed using the Source button on the monitor or using the buttons on the remote controller (when the OSD Mode Label is set to ON. The default setting is OFF.)

To use the menus, do the following:

1. Press the MENU button to access the Main menu.
2. Use the up and down arrow buttons (▲ and ▼) to highlight a selection.
3. Press ENTER to select an item.
4. Use the up and down arrow buttons (▲ and ▼) to highlight a selection.
5. Use the ◀ /VOL- and ▶ /VOL+ arrow buttons to adjust the setting of a selected item.

MAIN MENU



	VIDEO-1	NTSC
	Brightness	50
PICTURE	Contrast	50
SCREEN	Sharpness	9
SET UP	Color	50
PVM SETUP	Tint	50
CYCLE SETUP	Color Temp	User
CAMERA	Red	50
	Green	50
Maintenance	Blue	50

Figure 7. Main Menu

MENU DISPLAY

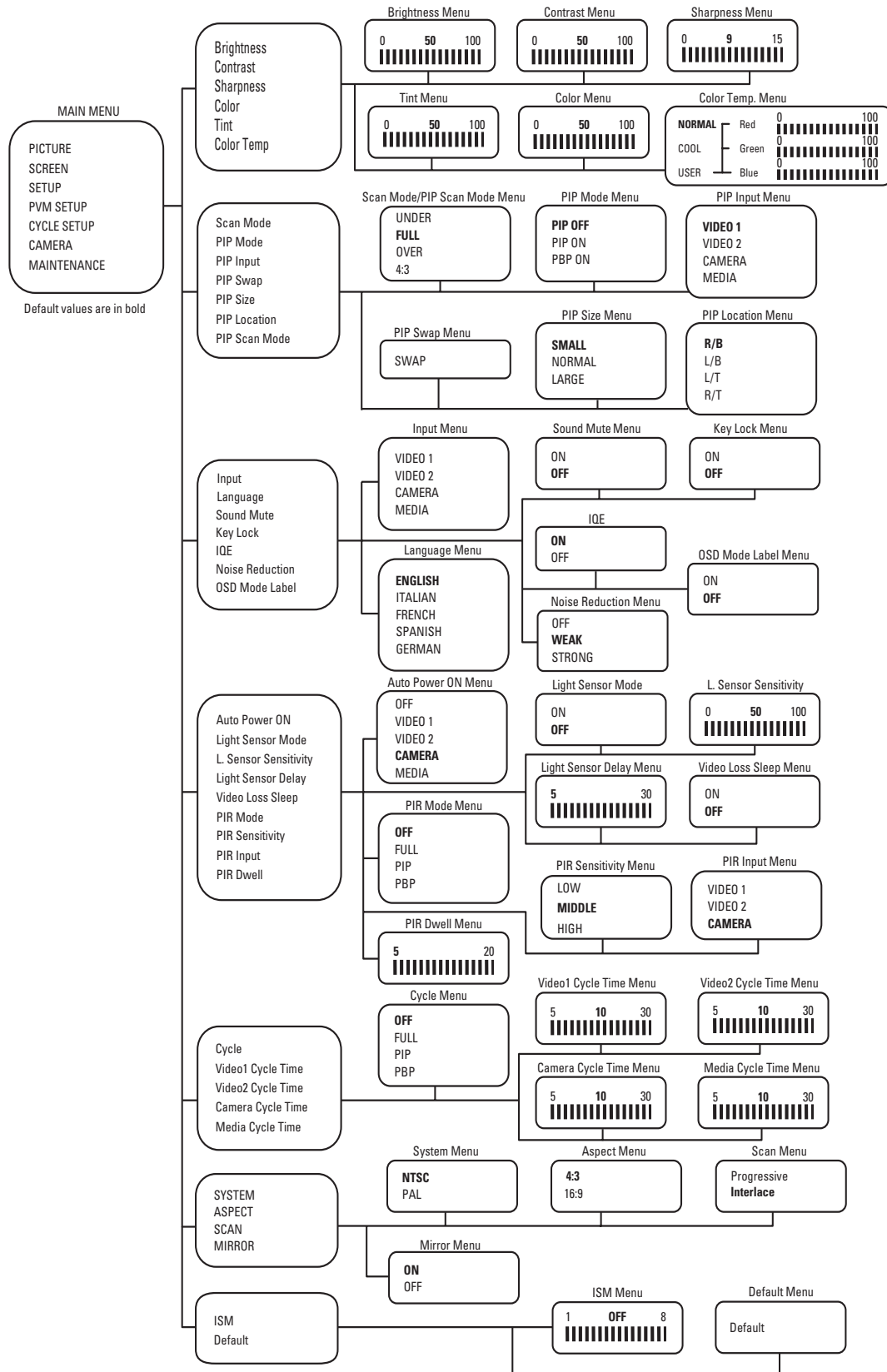

Figure 8. Menu Tree

MENU FIELD DEFINITIONS

PICTURE

Brightness: Adjusts the white level of the video screen image (0 to 100).

Contrast: Adjusts the black level of the video screen image (0 to 100).

Sharpness: Adjusts the picture softer or sharper (0 to 15).

Color: Adjusts the color saturation of the video signal (0 to 100).

Tint: Adjusts the range of color: green to red (0 to 100). This function is only available in NTSC mode; it is not available in PAL/SECAM.

Color Temp: Selects the temperature: Normal, Cool, or USER.

If you select USER, then choose from the following calibrations:

- **Red:** Adjusts gain for red (0 to 100).
- **Green:** Adjusts gain for green (0 to 100).
- **Blue:** Adjusts gain for blue (0 to 100).

SCREEN

Scan Mode: Select UNDER, FULL, OVER, or 4:3. The default setting is FULL. (The 4:3 mode only applies to the 26-inch model.)

PIP Mode: Select PIP OFF, PIP ON, or PBP ON.

PIP Input: Select VIDEO 1, VIDEO 2, CAMERA, or MEDIA. (Audio will not play when a file is displayed in the PIP window. To play audio, the file must be displayed in the main window.)

PIP Swap: Select SWAP to change from MAIN to PIP.

PIP Size: Select the PIP size: SMALL, NORMAL, or LARGE.

PIP Location: Select the PIP location: R/B (right bottom), L/B (left bottom), L/T (top left), or R/T (top right).

PIP Scan Mode: Select the PIP size for the screen: UNDER, FULL, OVER, or 4:3. The default setting is FULL. (The 4:3 mode only applies to the 26-inch model.)

SETUP

Input: Select VIDEO 1, VIDEO 2, CAMERA, or MEDIA.

Language: Select ENGLISH, ITALIAN, FRENCH, SPANISH, or GERMAN, for the OSD display.

Sound Mute: Select ON (silences the sound) or OFF (returns the sound).

Key Lock: Prevents unauthorized operation of the equipment by locking the buttons. Authorized users can release the key lock feature by pressing and holding the SOURCE button for five seconds.

IQE: Select ON or OFF for the image quality enhancement (IQE) function; this feature is only available on the 26-inch model. IQE technology can generate optimum picture quality without shortening the LCD's lifetime. It can regenerate vivid and rich color with accurate color reproduction, display a high contrast picture with automatic black/white stretching, and create a sharper display with horizontal edge enhancement.

Noise Reduction: Select OFF, WEAK, or STRONG to control the video signal's background noise.

OSD Mode Label: Select ON or OFF. ON displays the Mode (input source) OSD.

PVM Setup

Auto Power ON: Select the video input to be activated when power is restored after an electricity failure. Select OFF, VIDEO 1, VIDEO 2, CAMERA, or MEDIA.

Light Sensor Mode: Automatically turns on or off the monitor based on the light intensity.

L. Sensor Sensitivity: Sets the light intensity at which the monitor is turned off and on (1 to 100). The 100 setting is the more sensitive.

Light Sensor Delay: Sets the time that the Auto Day/Night feature pauses before being activated (5 to 30 seconds).

Video Loss Sleep: This is an ON/OFF function. ON sets the function that puts the monitor in sleep mode after video has been lost for 30 seconds. When a signal is detected, the monitor turns on again. To restore power immediately, use the power button on the remote control or the power button on the side of the PVM cabinet.

PIR Mode: Sets the motion detection mode : OFF, FULL, PIP, or PIP. This determines the length of time a selected video source triggered by motion detection displays on the screen (5 to 20 seconds).

PIR Sensitivity: Sets the motion detection sensitivity: LOW, MIDDLE, and HIGH. The typical detection for LOW is 16.4 to 23.0 feet (5 to 7 m); for MIDDLE, 26.2 to 32.8 feet (8 to 10 m); and for HIGH, 32.8 to 45.9 feet (10 to 14 m).

PIR Input: Sets the video input that displays when motion is detected. Select VIDEO 1, VIDEO 2, or CAMERA.

PIR Dwell: Sets the length of time a selected video source triggered by motion detection displays on the screen (5 to 20 seconds).

CYCLE SETUP

Cycle: Sets the cycle of the input source: OFF, FULL, PIP, or PBP. The settings OFF and FULL are only available if PIR Mode is set to PIP or PBP.

Video1 Cycle Time: Sets the cycle time of Video 1 (OFF, 5 to 30 seconds).

Video2 Cycle Time: Sets the cycle time of Video 2 (OFF, 5 to 30 seconds).

Camera Cycle Time: Sets the cycle time of Camera (OFF, 5 to 30 seconds).

Media Cycle Time: Sets the cycle time of Media (OFF, 5 to 30 seconds). When this feature is set to OFF, the cycle will skip the input.

CAMERA

This menu displays when there is camera input.

SYSTEM: Select NTSC or PAL.

ASPECT: Select 4:3 or 16:9.

SCAN: Select Progressive or Interlace mode.

MIRROR: Sets the camera image to be flipped horizontally (ON or OFF).

MAINTENANCE

ISM: Image sticking minimization (ISM) reduces “sticking” or retention of an image that displays for a long period time.

If selected, the ISM function starts 10 minutes after the PVM enters “sleep mode” through the light sensor setting.

NOTE: The panel backlight is not lit during this operation.

The operation period can be set from 1 to 8 hours.

Once the function begins, wait for the period you selected to end before normal operation resumes. If necessary, you can end the ISM function by returning the environment light back to normal intensity, which “wakes up” the PVM. A second method would be to cycle power to the unit using the remote control, the power button on the side of the unit, or the power source.

Default: Select Default to return to the default settings (refer to Figure 8 on page 15); default settings are boldface.

MEDIA CONTROL

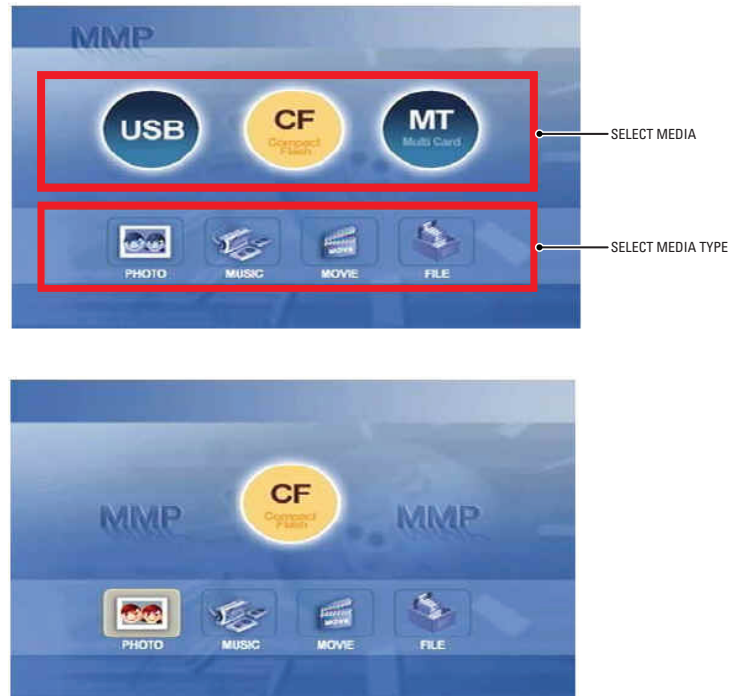

Figure 9. Media Type Selection Screen

Press the Media Menu button on the remote control to access the Media menu. Use the left and right arrow buttons (◀ and ▶) to highlight the desired media. Press the ENTER button.

Select the media type by using the left and right arrow buttons (◀ and ▶) in the Media menu. Press the ENTER button to play the slide show.



Figure 10. Slide Show Screen

Select the desired picture using the left and right arrow buttons (◀ and ▶). Press Play (or Enter) to play the slide show.

To change a setting value of the slide show option, press the Media Menu button while in the slide show screen (refer to Figure 10).

Media Menu Display

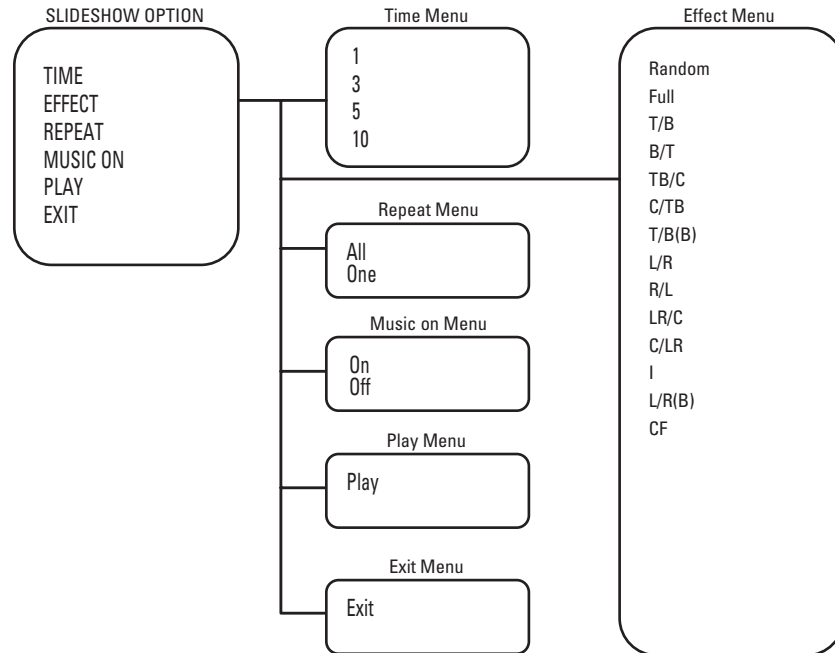

Figure 11. Media Menu Tree

Slide Show Option Field Definitions

TIME: Sets the length of time a selected picture displays on the screen in slide show mode: 1, 3, 5, or 10 seconds. The default setting is 5 seconds.

EFFECT: Sets the display effect while changing to the next picture in slide show mode.

- **Random:** Mixes the display effects below. The default setting is Random.
- **Full:** Changes the displayed picture to the next picture in full-screen mode.
- **T/B (top>bottom):** Fades in/out the next picture from top to bottom.
- **B/T (bottom>top):** Fades in/out the next picture from bottom to top.
- **TB/C (top & bottom>center):** Starts the next picture's fade in/out at the top and bottom simultaneously, and then finishes at the center of the screen.
- **C/TB (center>top & bottom):** Starts the fade in/out at the center of the screen, and then finishes at the top and bottom simultaneously.
- **T/B(B) (top>bottom [blind]):** Fades in/out with the picture divided vertically into four parts.
- **L/R (left>right):** Fades in/out from left to right.
- **R/L (right >left):** Fades in/out from right to left.
- **LR/C (left & right>center):** Starts the next picture's fade in/out at the left and right simultaneously, and then finishes at the center of the screen.
- **C/LR (center>left & right):** Starts the next picture's fade in/out at the center of the screen, and then finishes at the left and right simultaneously.
- **I (implode):** Fades in/out starting at the screen's four corners, and then finishes at the center of the screen.
- **L/R (B) (left>right [blind]):** Fades in/out with the picture divided horizontally into four parts.
- **CF (cross fade):** Fades in/out the next picture with a full picture.

REPEAT: Sets how the slide show plays: All or One. When this feature is set to All, all of the pictures in the slide show play repeatedly.

MUSIC ON: Sets the audio file to play or not play in slide show mode.

PLAY: Plays the slide show.

EXIT: Exits the slide show menu.

REPLACING THE CAMERA

NOTE: You must wear lead-free gloves and use ESD (electrostatic discharge) equipment when handling cameras.

CAMERA REMOVAL

1. Place the monitor face down, being careful not to scratch or touch the screen.
2. Use the thumb screw on the bottom of the monitor to open the access door. Refer to Figure 12.

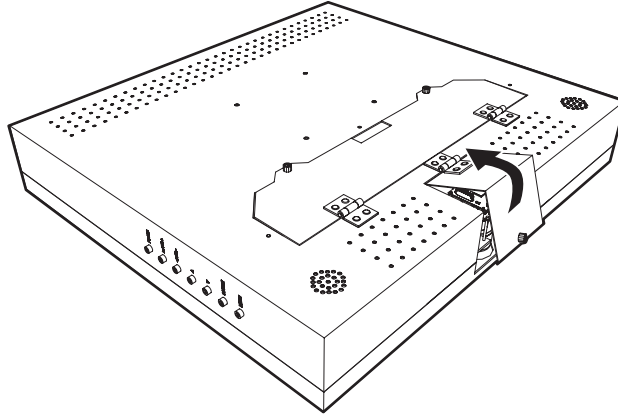

Figure 12. Access Door

3. Unscrew the three metric screws (14 mm) that secure the camera. Remove the screws and spacers.
4. Gently pull the camera out of the monitor, being careful not to damage the attached connection leads. Detach the two camera connection leads from the camera.

DIP SWITCH SETTINGS

1. Locate the DIP switch. 2. the switches for your installation using a small screwdriver, refer to Figure 13.

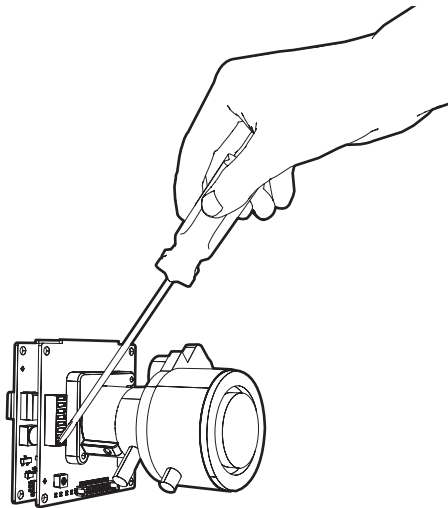

Figure 13. DIP Switches

SW1-1 Video Format

SW1-1 is controlled through the on-screen menu.

SW1-2 Line Sync

When multiple cameras are connected to the same switching device, vertical roll can occur on the monitor. AC line lock eliminates vertical roll by locking the frame rate to the power supply frequency. Each camera output is synchronized to the power supply frequency.

Internal line sync disables line lock and synchronizes cameras internally.

Set SW1-2 to OFF to use AC line lock. Set it to ON to use internal line sync. The default setting is OFF.

SW1-3 Interlaced Scanning/Progressive Scanning

SW1-3 is controlled through the on-screen menu.

SW1-4 Auto White Balance/Manual White Balance

Auto white balance (AWB) is enabled by default (OFF).

To manually set and lock the white balance:

1. Set SW1-4 to ON.
2. Hold a white background in front of the lens until the video shows all white.
3. While holding the background in place, set SW1-4 to OFF. A green block and a white block alternate briefly on the video image until the manual white balance (MWB) process is complete.

SW1-5 Fluorescent/General

Enable this option to adjust the camera for the best operation under fluorescent lighting.

Set SW1-5 to OFF for fluorescent lighting. Set it to ON for general lighting. The default setting is ON.

NOTE: If you use fluorescent operation, you should use AC line lock for best results.

SW1-6 General WDR/Maximum WDR

Maximum WDR supports approximately 36 dB of additional dynamic range over a standard camera. Use it for installations that require the maximum WDR.

General WDR supports approximately 20 dB of additional dynamic range over a standard camera. Use it for installations that do not require the maximum WDR.

Set SW1-6 to ON to select maximum WDR. Set it to OFF to select general WDR. The default setting is ON.

CAMERA INSTALLATION AND CAMERA ADJUSTMENT

1. Plug the two camera connection leads from inside the monitor into the connectors on the camera.
2. Attach the camera using three spacers and three screws (14 mm). Do NOT overtighten the screws or the spacers will collapse. The focus knobs need to be positioned as shown in Figure 14 on page 22.
3. Tuck the camera leads neatly into the monitor.
4. Verify the video on the monitor. If satisfactory, close the door. Hand-tighten the thumbscrew. If unsatisfactory, go to step 5.
5. The camera focus and zoom come from the factory with a medium setting. They can be adjusted with the built-in camera located inside the monitor. Refer to Figure 14 on page 22.

To adjust the camera zoom, adjust the zoom and lightly tighten the focus knob.

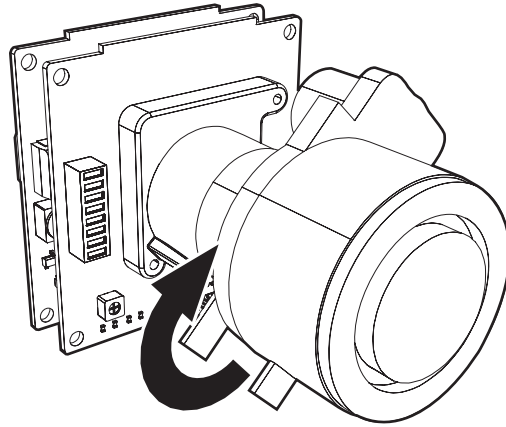

Figure 14. Adjusting the Camera

6. Close the door and hand-tighten the door thumbscrew.

Specifications

MODELS

PMP20B	20-inch (510 mm) LCD black monitor with WDR camera
PMP20W	20-inch (510 mm) LCD white monitor with WDR camera
PMP26B	26-inch (660 mm) LCD black monitor with WDR camera
PMP26W	26-inch (660 mm) LCD white monitor with WDR camera

GENERAL

Native Resolution	
PMP20B, PMP20W	640 x 480 VGA
PMP26B, PMP26W	1366 x 768 WXGA
Panel Aspect Ratio	
PMP20B, PMP20W	4:3
PMP26B, PMP26W	16:9
Viewing Area	
PMP20B, PMP20W	408 x 306 mm
PMP26B, PMP26W	576 x 324 mm
Pixel Pitch	
PMP20B, PMP20W	0.638 x 0.638 mm
PMP26B, PMP26W	0.422 x 0.422 mm
Brightness	450 cd/m ²
Contrast Ratio	800:1
Backlight Type	
PMP20B, PMP20W	6 CCFL
PMP26B, PMP26W	12 EEFL
Panel Life	50,000 hours
Viewing Angle (H/V)	89°/89°/89°/89°
Display Colors	16.7 million
PIP	Selectable, sizable, swappable, moveable
PBP	Swappable
Response Time	
PMP20B, PMP20W	25 ms
PMP26B, PMP26W	8 ms
Speakers	2, internal
Front Panel Controls	Power, source/enter, menu/exit, up, down, volume minus, volume plus
Indicators	LED (power on/off)
Media Card	CompactFlash (CF) type I/II, IBM Microdrive™, MultiMediaCard (MMC), Secure Digital (SD) card, mini-Secure Digital card, Sony Memory Stick™, Memory Stick Duo™, Memory Stick Pro™, Memory Stick Pro Duo™, USB
Media Formats	JPEG, MPEG1, MPEG2, MPEG4, DIVX, MP3
Image Format	Baseline JPEG (.jpg, .jpeg); maximum resolution 5120 x 3840 Progressive JPEG; maximum resolution 2048 x 1536
Audio Format	MP3, Data Rate: 128/160/192/256/320kbps, Sampling Rate: 32/44.1/48kHz, Not supported ID3 tag, MP3i, MP3 Pro

ELECTRICAL

Input Voltage	24 VAC (50/60 Hz)
Power Consumption	
PMP20B, PMP20W	96 W (4.0 A)
PMP26B, PMP26W	160 W (6.7 A)
Input Interfaces	Video: 2 BNC Media card (refer to <i>General</i> on page 23 section)
Output interfaces	1 BNC Camera
Horizontal Frequency	15.75/16.25 kHz
Vertical Frequency	50/60 Hz

ENVIRONMENTAL

Operating Temperature	32° to 104°F (0° to 40°C)
Storage Temperature	-4° to 140°F (-20° to 60°C)
Operating Humidity	20% to 80%, noncondensing
Storage Humidity	10% to 90%, noncondensing

PHYSICAL

Dimensions	
PMP20B, PMP20W	3.1" D x 18.5" W x 16.7" H (7.9 x 47.0 x 42.5 cm)
PMP26B, PMP26W	4.1" D x 26.1" W x 17.6" H (10.3 x 66.3 x 44.7 cm)
Unit Weight	
PMP20B, PMP20W	23.2 lb (10.5 kg)
PMP26B, PMP26W	32.0 lb (14.5 kg)
Shipping Weight	
PMP20B, PMP20W	28 lb (13 kg)
PMP26B, PMP26W	39 lb (18 kg)

CAMERA SPECIFICATIONS

Imaging Device	1/3-inch pixel-based imager
Picture Elements	720 (H) x 540 (V)
Dynamic Range	102 dB typical, 120 dB maximum
Scanning System	2:1 interlace/progressive
Horizontal Resolution	
NTSC	504 TV lines
PAL	504 TV lines
Signal-to-Noise Ratio	>53 dB
Minimum Illumination	
Color (Day)	0.8 lux
SENS 8X	0.2 lux
Gain Control	Auto (36 dB maximum)
Exposure	Auto (1/15 to 1/22,000)
White Balance	Auto or manual, 2800°K to 7500°K
Backlight Compensation	Auto
Sync Format	NTSC/PAL

LENS SPECIFICATIONS

Focal Length	3.0 mm to 9.0 mm
Format Size	1/3-inch
F-Number	f/1.5-3.0
Operation	
Iris	Auto
Focus	Manual
Zoom	Manual
Angle of View*	
Horizontal	32.4° to 13.6°
Diagonal	41.4° to 17.2°
Vertical	23.8° to 10.2°

*Focal length specifications presume a 10% horizontal and 4% vertical monitor overscan.

OPTIONAL MOUNTS

PMCL-WM	Wall mount
PMCL-WMT	Tilt/swivel wall mount
PMCL-CM	Ceiling mount
PMCL-CMP	Ceiling mount with pole
PMCL-WM1A	Single-arm wall mount
PMCL-WM2A	Dual-arm wall mount

RECOMMENDED POWER SUPPLIES

WCS1-4	(Used for the PMP20B/W units only) 100/120/240 VAC input outdoor camera power supply; one 24/26/28 VAC output
WCS4-20	120/240 VAC input outdoor multiple camera power supply; four fused 24/28 VAC outputs

NOTES:

- A power supply is not included.
- All power supplies must meet the power requirements specified in *Electrical* on page 24.

CERTIFICATIONS

- CE, Class A
- FCC, Class A
- UL/cUL Listed

(Design and product specifications subject to change without notice.)

PRODUCT WARRANTY AND RETURN INFORMATION

WARRANTY

Pelco will repair or replace, without charge, any merchandise proved defective in material or workmanship **for a period of one year** after the date of shipment.

Exceptions to this warranty are as noted below:

- Five years on fiber optic products and TW3000 Series unshielded twisted pair (UTP) transmission products.
- Three years on Spectra® IV products.
- Three years on Genex® Series products (multiplexers, server, and keyboard).
- Three years on DX Series digital video recorders, DVR5100 Series digital video recorders, DigitalSENTRY® Series hardware products, DVX Series digital video recorders, NVR300 Series network video recorders, and Endura® Series distributed network-based video products.
- Three years on Camclosure® and Pelco-branded fixed camera models, except the CC3701H-2, CC3701H-2X, CC3751H-2, CC3651H-2X, MC3651H-2, and MC3651H-2X camera models, which have a five-year warranty.
- Three years on PMCL200/300/400 Series LCD monitors.
- Two years on standard motorized or fixed focal length lenses.
- Two years on Legacy®, CM6700/CM6800/CM9700 Series matrix, and DF5/DF8 Series fixed dome products.
- Two years on Spectra III™, Spectra Mini, Esprit®, ExSite®, and PS20 scanners, including when used in continuous motion applications.
- Two years on Esprit and WW5700 Series window wiper (excluding wiper blades).
- Two years (except lamp and color wheel) on Digital Light Processing (DLP®) displays. The lamp and color wheel will be covered for a period of 90 days. The air filter is not covered under warranty.
- Two years on Intelli-M® eIDC controllers.
- One year (except video heads) on video cassette recorders (VCRs). Video heads will be covered for a period of six months.
- Six months on all pan and tilts, scanners, or preset lenses used in continuous motion applications (preset scan, tour, and auto scan modes).

Pelco will warrant all replacement parts and repairs for 90 days from the date of Pelco shipment. All goods requiring warranty repair shall be sent freight prepaid to a Pelco designated location. Repairs made necessary by reason of misuse, alteration, normal wear, or accident are not covered under this warranty.

Pelco assumes no risk and shall be subject to no liability for damages or loss resulting from the specific use or application made of the Products. Pelco's liability for any claim, whether based on breach of contract, negligence, infringement of any rights of any party or product liability, relating to the Products shall not exceed the price paid by the Dealer to Pelco for such Products. In no event will Pelco be liable for any special, incidental, or consequential damages (including loss of use, loss of profit, and claims of third parties) however caused, whether by the negligence of Pelco or otherwise.

The above warranty provides the Dealer with specific legal rights. The Dealer may also have additional rights, which are subject to variation from state to state.

If a warranty repair is required, the Dealer must contact Pelco at (800) 289-9100 or (559) 292-1981 to obtain a Repair Authorization number (RA), and provide the following information:

1. Model and serial number
2. Date of shipment, P.O. number, sales order number, or Pelco invoice number
3. Details of the defect or problem

If there is a dispute regarding the warranty of a product that does not fall under the warranty conditions stated above, please include a written explanation with the product when returned.

Method of return shipment shall be the same or equal to the method by which the item was received by Pelco.

RETURNS

To expedite parts returned for repair or credit, please call Pelco at (800) 289-9100 or (559) 292-1981 to obtain an authorization number (CA number if returned for credit, and RA number if returned for repair) and designated return location.

All merchandise returned for credit may be subject to a 20 percent restocking and refurbishing charge.

Goods returned for repair or credit should be clearly identified with the assigned CA or RA number and freight should be prepaid.

1-8-08

 **Green** The materials used in the manufacture of this document and its components are compliant to the requirements of Directive 2002/95/EC.



This equipment contains electrical or electronic components that must be recycled properly to comply with Directive 2002/96/EC of the European Union regarding the disposal of waste electrical and electronic equipment (WEEE). Contact your local dealer for procedures for recycling this equipment.

REVISION HISTORY

Manual #	Date	Comments
C2943M	1/08	Original version.

Pelco, the Pelco logo, Camclosure, DigitalSENTRY, Endura, Esprit, ExSite, Genex, Intelli-M, Legacy, and Spectra are registered trademarks of Pelco, Inc.
Spectra III is a trademark of Pelco, Inc.
DLP is a registered trademark of Texas Instruments Incorporated.
VEESA is a registered trademark of the Video Electronics Standards Association.
IBM is a trademark of International Business Machines.

© Copyright 2008, Pelco, Inc. All rights reserved.



Worldwide Headquarters
3500 Pelco Way
Clovis, California 93612 USA

USA & Canada
Tel: 800/289-9100
Fax: 800/289-9150

International
Tel: 1-559/292-1981
Fax: 1-559/348-1120

www.pelco.com

ISO9001

Australia | Canada | Finland | France | Germany | Italy | Macau | The Netherlands | Russia | Singapore
South Africa | Spain | Sweden | United Arab Emirates | United Kingdom | United States

Free Manuals Download Website

<http://myh66.com>

<http://usermanuals.us>

<http://www.somanuals.com>

<http://www.4manuals.cc>

<http://www.manual-lib.com>

<http://www.404manual.com>

<http://www.luxmanual.com>

<http://aubethermostatmanual.com>

Golf course search by state

<http://golfingnear.com>

Email search by domain

<http://emailbydomain.com>

Auto manuals search

<http://auto.somanuals.com>

TV manuals search

<http://tv.somanuals.com>