

MCS Series Master Power Supply

Installation/ Operation Manual

C653M-D (9/03)

Pelco • 3500 Pelco Way • Clovis, CA 93612-5699 USA www.pelco.com
In North America and Canada: Tel (800) 289-9100 or FAX (800) 289-9150
International Customers: Tel +1 (559) 292-1981 or FAX +1 (559) 348-1120

IMPORTANT SAFEGUARDS AND WARNINGS

Observe the following warnings before installing and using this product.

1. Read these instructions.
2. Keep these instructions.
3. Heed all warnings.
4. Follow all instructions.
5. Do not use this apparatus near water.
6. Clean only with dry cloth.
7. Do not block any ventilation openings. Install in accordance with the manufacturer's instructions.
8. Do not install near any heat sources, such as radiators, heat registers, stoves, or other apparatus (including amplifiers) that produce heat.
9. Only use attachments/accessories specified by the manufacturer.
10. Use only with the cart, stand, tripod, bracket, or table specified by the manufacturer or sold with the apparatus. When a cart is used, use caution when moving the cart/apparatus combination to avoid injury from tip-over.
11. Refer all servicing to qualified service personnel. Servicing is required when the apparatus has been damaged in any way, such as power-supply cord or plug is damaged, liquid has been spilled or objects have fallen into the apparatus, the apparatus has been exposed to rain or moisture, the apparatus does not operate normally, or the apparatus has been dropped.
12. Apparatus shall not be exposed to dripping or splashing, and no objects filled with liquids, such as vases, shall be placed on the apparatus.
13. To reduce the risk of shock, do not perform any servicing other than that contained in the operating instructions unless you are qualified to do so.
14. An ALL-POLE MAINS SWITCH with a contact separation of at least 3 mm in each pole shall be incorporated in the electrical installation of the building.
15. The installation method and materials should be capable of supporting four times the weight of the unit.
16. Only use replacement parts Pelco recommends.
17. After replacing/repairing this unit's electrical components, conduct a resistance measurement between line and exposed parts to verify the exposed parts have not been connected to line circuitry.



WARNING: To reduce the risk of fire or electric shock, do not expose this apparatus to rain or moisture.



WARNING: Risk of fire; do not inter-connect outputs.

The product and/or manual may bear the following marks:



This symbol indicates that dangerous voltage constituting a risk of electric shock is present within this unit.



This symbol indicates that there are important operating and maintenance instructions in the literature accompanying this unit.

CAUTION:

RISK OF ELECTRIC SHOCK.
DO NOT OPEN.

Please thoroughly familiarize yourself with the information in this manual prior to installation and operation.

DESCRIPTION

The MCS Series consists of multi-output 24 VAC indoor power supplies. These power supplies provide output for 4, 8, or 16 cameras from a single source and come in 2, 5, 10, and 20 amp capacities. To compensate for voltage losses over long wire runs, 28 VAC outputs are also available on most models. The power supplies allow for 120 or 240 VAC line input. Higher capacity models can handle pan and tilt and receiver operation in addition to the camera when they are used with integrated systems such as the Spectra® dome and Esprit® Integrated Positioning System.

Each output on the MCS “S” and “SB” (switched) Series models features its own LED power indicator and three-position switch (up = 24 VAC, center = off, down = 28 VAC). The switch lets you individually turn each output off or quickly select between 24 and 28 VAC without reconnecting wires.

All MCS Series models are available with either glass fuses or self-resetting circuit breakers (poly switches). The following bullets explain the advantages and disadvantages of each type:

- Glass fuses provide more protection than circuit breakers because they act faster and are more precise. However, they are designed for one-time use and must be replaced when they blow.
- Circuit breakers reset themselves when the fault is corrected, which eliminates the need to replace fuses. However, they react more slowly, are affected by temperature, and are not nearly as accurate—the amount of current required to trip one can vary as much as 100 percent.

Since circuit breaker models do not require fuses and automatically reset themselves after the fault is corrected, the breakers are not accessible.

MODELS

Model Number	Outputs	Supply Current (Amps)	Max Current Per Channel (Amps)	Input Voltage (VAC)	Output Voltage (VAC)	Required Input Current (Amps)	Fuses	Circuit Breakers	Surge Protection	Class 2 Outputs	On/Off Switch	Power LED
MCS4-2	4	2	1	120/240	24	0.44	X		X		X	X
MCS4-2B	4	2	1	120/240	24	0.44		X	X	X	X	X
MCS8-5	8	5	3	120/240	24, 28	1.10/0.57	X		X		X	X
MCS8-5B	8	5	3	120/240	24, 28	1.10/0.57		X	X	X	X	X
MCS16-10	16	10	3	120/240	24, 28	2.20/1.15	X		X		X	X
MCS16-10B	16	10	3	120/240	24, 28	2.20/1.15		X	X	X	X	X
MCS16-10S	16	10	3	120/240	24, 28	2.20/1.15	X		X		16	16
MCS16-10SB	16	10	3	120/240	24, 28	2.20/1.15		X	X	X	16	16
MCS16-20	16	20	3	120/240	24, 28	4.40/2.30	X		X		X	X
MCS16-20B	16	20	3	120/240	24, 28	4.40/2.30		X	X	X	X	X
MCS16-20S	16	20	3	120/240	24, 28	4.40/2.30	X		X		16	16
MCS16-20SB	16	20	3	120/240	24, 28	4.40/2.30		X	X	X	16	16

APPLICATION EXAMPLES

Table A contains examples of products and the number of units that can be powered by each power supply, and is based on the vA rating of each product.

Table A. Product Capacity

Product	Power Supply Model			
	MCS4-2/ MCS4-2B	MCS8-5/ MCS8-5B	MCS16-10/ MCS16-10B/ MCS16-10S/ MCS16-10SB	MCS16-20/ MCS16-20B/ MCS16-20S/ MCS16-20SB
CCD Camera (12 vA maximum)	4	8	16	16
DF5/DF5S with camera (3 vA)	4	8	16	16
DF8A/PDF8 (12 vA maximum)	4	8	16	16
Indoor Spectra® (30 vA)	1	4	8	16
Esprit® without wiper or IOC/IOP (50 vA)	—	2	4	8

INSTALLATION

To install an MCS Series Power Supply, perform the following steps:

1. Punch out the necessary knockouts. (Two knockout holes are provided on the bottom for either 1/2-inch (1.27 cm) or 3/4-inch (1.91 cm) conduit fittings for the incoming (main) power. Six knockout holes are provided on the top for either 1/2-inch (1.27 cm) or 3/4-inch (1.91 cm) conduit fittings for the output (24-28V) power.
2. Open the lid on the unit by removing the 8-32 Phillips screw.
3. Install conduit fittings (not provided).
4. Determine the location of the unit.
5. Refer to Figure 1. Drill holes in the mounting surface (two of the mounting holes are inside the unit). Use the unit as a template.
6. Attach the unit securely with four fasteners (not supplied) of the appropriate length. You can use fasteners up to 5/16-inch (0.80 cm) in diameter.

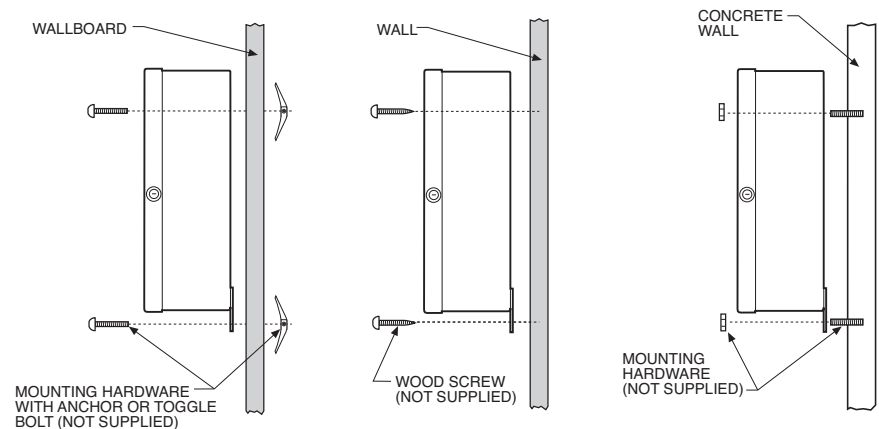

Figure 1. Power Supply Mounting

INPUT CONNECTIONS



WARNING: Pelco shall not be liable for any damages resulting from incorrect wiring or improper loading of an MCS Series Power Supply.



WARNING: Units are equipped for 120 VAC line voltage at the factory. If you are using 240 VAC, you must change the main fuse (fuse models) and change the voltage selector switch. If 240 VAC power is applied with the selector switch set to 120 VAC, the main fuse will blow (fuse models) or the thermal breaker will open (breaker models).

1. Verify that the on/off switch inside the box is OFF. On MCS "S" and "SB" (switched) models, verify that the switch for each output is at the center (OFF) position.
2. Refer to Figure 2 or 3. Remove the high-voltage compartment panel inside the box. Set the input voltage selector switch inside the compartment to the appropriate line voltage. The switch is set at the factory for 120 VAC line voltage.
3. If you are using 120 VAC line voltage, go to step 4. If you have a fuse model and are using 240 VAC line voltage, remove the 120 VAC fuse from the fuse holder directly above the power switch and install the appropriate fuse (refer to Table B). Find the fuse in the bag located inside the high-voltage compartment. (Extra fuses are supplied for spares.)
4. Attach the 120/240 input wires to the flying leads in the compartment with the supplied wire nuts. Connect the black wire to the AC line lead. Connect the white wire to the AC neutral lead.
5. Attach the input ground wire to the stud inside the compartment with the supplied washer and nut.
6. Replace the access panel.

Table B. Fuse Determination Table

Line Voltage	MCS4-2	MCS4-2B*	MCS8-5	MCS8-5B	MCS16-10/ MCS16-10S	MCS16-10B/ MCS16-10SB	MCS16-20/ MCS16-20S	MCS16-20B/ MCS16-20SB
120 VAC	1 A	1 A	1.6 A	N/A	3 A	N/A	5 A	N/A
240 VAC	0.5 A	0.5 A	1 A	N/A	1.6 A	N/A	3 A	N/A

N/A - Model is not equipped with a primary input fuse; transformer is protected with thermal breaker.

* - MCS4-2B uses a fuse for the high-voltage line input and provides breakers for the low-voltage output channels.

OUTPUT CONNECTIONS



CAUTION: Under light load conditions and high power line input voltage from the utility company, output voltage from the power supply (28 VAC taps only) may reach 32 VAC. This voltage can cause over-voltage damage on 24 VAC devices. Keep in mind, certain devices produce variable loads (due to heaters, blowers, and pan and tilt motion) and during minimum requirements may create a light load condition, causing excessive voltage. Therefore, Pelco recommends using a 28 VAC tap only when the supplied wire size for the given load causes an unacceptable output voltage on the 24 VAC tap. Refer to Table D to determine acceptable situations for the 28 VAC tap.

Perform the following steps to attach 24 VAC devices to the MCS Series Power Supply:

1. Refer to Tables C and D in this manual or the wiring table on the unit's lid to determine the output wiring needed for your devices.
2. Refer to Figure 2 (or Figure 3 for "S" and "SB" models) for the proper connector strip connections, and do one of the following:
 - **Regular MCS Models:** For each device, attach one output wire to the COM (common) terminal. Attach the second wire to the appropriate 24V or 28V terminal.
 - **"S" and "SB" (Switched) Models:** For each device, attach one output wire to the COM (common) terminal and the second wire to the 24/28V terminal.
3. When you finish the wiring connections, double-check the installation for safety purposes.
4. Power up the unit with the on/off switch. On MCS "S" and "SB" (switched) models, move the switch to the appropriate output voltage position (up = 24 VAC, down = 28 VAC) to provide power.
5. Use a voltmeter to verify that used outputs are at appropriate voltage levels.
6. Close the lid and secure it using the 8-32 Phillips screw.

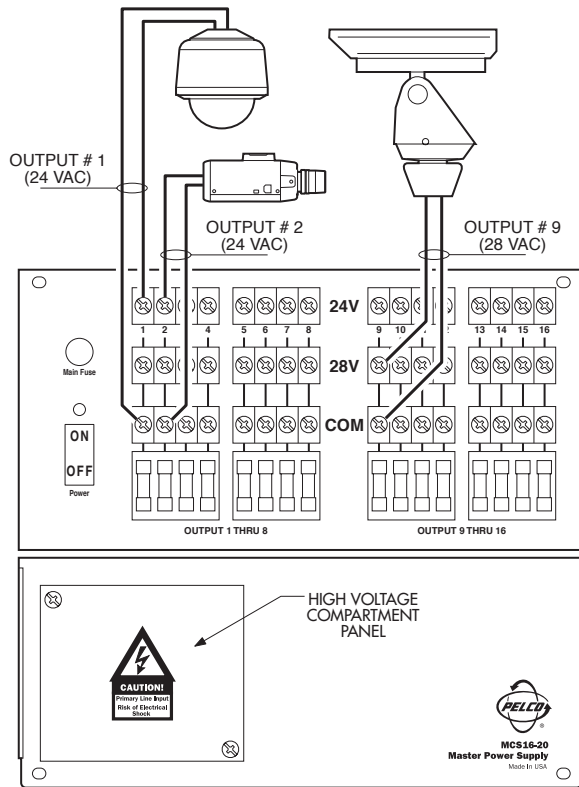

Figure 2. MCS Unit Wiring Connector Diagram

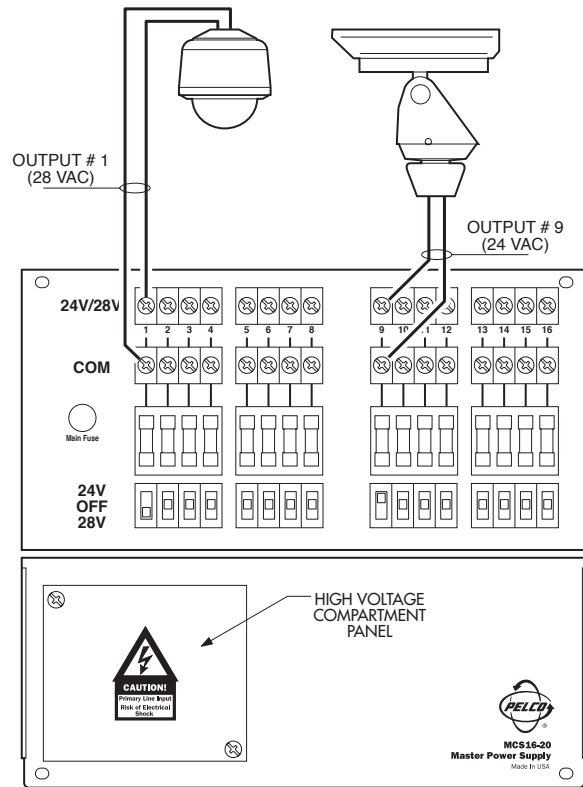

Figure 3. MCS "S" and "SB" Unit Wiring Connector Diagram

Table C. Recommended Wiring Distances

The following are the recommended maximum distances (transformer to load) and are calculated with a 10-percent voltage drop. (Ten percent is generally the maximum allowable voltage drop for AC-powered devices.) Distances are calculated in feet; values in parentheses are meters.

Input Voltage	Total VA Consumed	Wire Gauge					
		20		18		16	
24 VAC	10	283	(86)	451	(137)	716	(218)
	20	141	(42)	225	(68)	358	(109)
	30	94	(28)	150	(45)	238	(72)
	50	56	(17)	90	(27)	143	(43)
28 VAC	10	386	(117)	614	(187)	975	(297)
	20	193	(58)	307	(93)	487	(148)
	30	128	(39)	204	(62)	325	(99)
	50	77	(23)	122	(37)	195	(59)

You can use Table D as a guide to determine the necessary wire gauge (AWG) for various cable distances that provide 24 VAC power. Or use it in a reverse fashion to determine the maximum allowable cable distance for a particular wire gauge. Table D applies when using 2-conductor copper wire, with characteristics similar to West Penn 221-227 unshielded cable. Calculations are based on a 10-percent voltage drop (generally the maximum allowable drop for AC-powered devices).

The minimum acceptable voltage is calculated as follows:

$$\begin{aligned}
 & 24.0 \text{ VAC} \\
 & - 02.4 \text{ (10\%)} \\
 & 21.6 \text{ (Minimum Acceptable Voltage)}
 \end{aligned}$$

The minimum acceptable voltage used to create Table D was 21.6 volts. Therefore, the 24-volt output has an acceptable range from 24 volts down to 21.6 volts; the 28 volt output's acceptable range is from 28 volts down to 21.6 volts.

Table D. Required Wire Gauge

Required Wire Gauge Table (AWG)

WIRE DIST (feet) ↓	CCD Camera	P/T480 Pan/Tilt	Indoor Spectra	PT570 Pan/Tilt	Esprit Pan/Tilt	Indoor XLS	CX9000 Rxr's	Outdoor Spectra	← Equipment Loads (VA)		
	10VA	20VA	30VA	40VA	50VA	60VA	70VA	80VA	90VA	100VA	200VA
1000	12-14 16-18	12 12-14	N/A 12-14	N/A 12	N/A N/A	N/A N/A	N/A N/A	N/A N/A	N/A N/A	N/A N/A	N/A N/A
900	12-14 16-18	12 14-16	12 12-14	N/A 12	N/A 12	N/A N/A	N/A N/A	N/A N/A	N/A N/A	N/A N/A	N/A N/A
800	12-14 16-18	12 14-16	12 12-14	N/A 12	N/A 12	N/A 12	N/A N/A	N/A N/A	N/A N/A	N/A N/A	N/A N/A
700	12-16 18-20	12 14-16	12 12-14	12 12-14	N/A 12	N/A 12	N/A N/A	N/A N/A	N/A N/A	N/A N/A	N/A N/A
600	12-16 18-20	12 14-18	12 14-16	12 12-14	N/A 12-14	N/A 12	N/A 12	N/A 12	N/A N/A	N/A N/A	N/A N/A
500	12-16 18-20	12-14 16-18	12 14-16	12 12-14	12 12-14	N/A 12-14	N/A 12	N/A 12	N/A 12	N/A N/A	N/A N/A
400	12-18 20-22	12-14 16-18	12 14-18	12 14-16	12 12-14	12 12-14	12 12-14	N/A 12	N/A 12	N/A 12	N/A N/A
300	12-18 20-22	12-16 18-20	12-14 16-18	12 14-18	12 14-16	12 14-16	12 12-14	12 12-14	12 12-14	N/A 12-14	N/A N/A
200	12-20 22	12-18 20-22	12-16 18-20	12-14 16-18	12-14 16-18	12 14-16	12 14-16	12 14-16	12 14-16	12 12-14	N/A 12-14
100	12-22 N/A	12-20 22	12-18 20-22	12-18 20-22	12-16 18-20	12-16 18-20	12-16 18-20	12-14 16-18	12-14 16-18	12-14 16-18	12 12-14

Allowable Wire Gauge (AWG) Using 24 Volt Tap

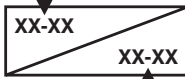

Allowable Wire Gauge (AWG) Using 28 Volt Tap

N/A - Distance and Load Not Recommended For Any Wire Size Between 12-22 (AWG)

MAINTENANCE

There are no user-serviceable parts except for the fuses. If the transformer in the unit does not work properly, contact the factory for return information. Refer to the *Warranty and Return Information* section of this manual.

Clean the outer surface of the power supply with a nonabrasive cleaning cloth and anti-static cleaner. Do not use kerosene or similar substances that may damage the surface.

SPECIFICATIONS

MECHANICAL

Cable Entry: Knockouts for either 1/2-inch (1.27 cm) or 3/4-inch (1.91 cm) conduit

Fuse Size
All Fuse Models: All fuses are 5 x 20 mm

ELECTRICAL

Input Voltage
All Models: 120 or 240 VAC, 50/60 Hz

Output Voltage
MCS4-2: 24 VAC
All Other Models: 24/28 VAC

Required Input Current: See *Models* section

Output Fuse Ratings

MCS4-2:	1 A
MCS8-5:	3 A
MCS16-10/16-10S:	3 A
MCS16-20/16-20S:	3 A

Output Circuit Breaker Ratings

MCS4-2B:	.9 A
MCS8-5B:	3 A
MCS16-10B/16-10SB:	3 A
MCS16-20B/16-20SB:	3 A

Input Connectors:	Wire nut
Output Connectors:	Screw-type barrier strips
Input Wire Size:	12-16 gauge solid wire
Output Wire Size:	12-22 gauge solid or stranded wire
Recommended Wiring Distances:	See Table C

GENERAL

Construction:	Steel
Finish:	Black polyester powder coat
Environment:	Indoor
Dimensions:	16.13 (H) x 10.86 (W) x 4.37 (D) inches (40.97 x 27.58 x 11.10 cm)
Approximate Unit Weight:	21.75 lb (9.87 cm)

RATINGS

NEMA 1

(Design and product specifications subject to change without notice.)

PRODUCT WARRANTY AND RETURN INFORMATION

WARRANTY

Pelco will repair or replace, without charge, any merchandise proved defective in material or workmanship for a period of one year after the date of shipment.

Exceptions to this warranty are as noted below:

- Five years on FT/FR8000 Series fiber optic products.
- Three years on Genex® Series products (multiplexers, server, and keyboard).
- Three years on Camclosure® and fixed camera models, except the CC3701H-2, CC3701H-2X, CC3751H-2, CC3651H-2X, MC3651H-2, and MC3651H-2X camera models, which have a five-year warranty.
- Two years on standard motorized or fixed focal length lenses.
- Two years on Legacy®, CM6700/CM6800/CM9700 Series matrix, and DF5/DF8 Series fixed dome products.
- Two years on Spectra®, Esprit®, ExSite™, and PS20 scanners, including when used in continuous motion applications.
- Two years on Esprit® and WW5700 Series window wiper (excluding wiper blades).
- Eighteen months on DX Series digital video recorders, NVR300 Series network video recorders, and Endura™ Series distributed network-based video products.
- One year (except video heads) on video cassette recorders (VCRs). Video heads will be covered for a period of six months.
- Six months on all pan and tilts, scanners or preset lenses used in continuous motion applications (that is, preset scan, tour and auto scan modes).

Pelco will warrant all replacement parts and repairs for 90 days from the date of Pelco shipment. All goods requiring warranty repair shall be sent freight prepaid to Pelco, Clovis, California. Repairs made necessary by reason of misuse, alteration, normal wear, or accident are not covered under this warranty.

Pelco assumes no risk and shall be subject to no liability for damages or loss resulting from the specific use or application made of the Products. Pelco's liability for any claim, whether based on breach of contract, negligence, infringement of any rights of any party or product liability, relating to the Products shall not exceed the price paid by the Dealer to Pelco for such Products. In no event will Pelco be liable for any special, incidental or consequential damages (including loss of use, loss of profit and claims of third parties) however caused, whether by the negligence of Pelco or otherwise.

The above warranty provides the Dealer with specific legal rights. The Dealer may also have additional rights, which are subject to variation from state to state.

If a warranty repair is required, the Dealer must contact Pelco at (800) 289-9100 or (559) 292-1981 to obtain a Repair Authorization number (RA), and provide the following information:

1. Model and serial number
2. Date of shipment, P.O. number, Sales Order number, or Pelco invoice number
3. Details of the defect or problem

If there is a dispute regarding the warranty of a product which does not fall under the warranty conditions stated above, please include a written explanation with the product when returned.

Method of return shipment shall be the same or equal to the method by which the item was received by Pelco.

RETURNS

In order to expedite parts returned to the factory for repair or credit, please call the factory at (800) 289-9100 or (559) 292-1981 to obtain an authorization number (CA number if returned for credit, and RA number if returned for repair).

All merchandise returned for credit may be subject to a 20% restocking and refurbishing charge.

Goods returned for repair or credit should be clearly identified with the assigned CA or RA number and freight should be prepaid. Ship to the appropriate address below.

If you are located within the continental U.S., Alaska, Hawaii or Puerto Rico, send goods to:

Service Department
Pelco
3500 Pelco Way
Clovis, CA 93612-5699

If you are located outside the continental U.S., Alaska, Hawaii or Puerto Rico and are instructed to return goods to the USA, you may do one of the following:

If the goods are to be sent by a COURIER SERVICE, send the goods to:

Pelco
3500 Pelco Way
Clovis, CA 93612-5699 USA

If the goods are to be sent by a FREIGHT FORWARDER, send the goods to:

Pelco c/o Expeditors
473 Eccles Avenue
South San Francisco, CA 94080 USA
Phone: 650-737-1700
Fax: 650-737-0933

REVISION HISTORY

Manual #	Date	Comments
C653M	3/99	Original version.
	5/99	Revisions made because fuses are no longer in a bag but in holders. Added weight.
C653M-A	8/99	Added material on the four "S" and "SB" (switched) power supply models.
C653M-B	6/00	Changed fuse installation information. Updated compliance information.
C653M-C	8/02	Added CE certification. Revised <i>Important Safeguards and Warnings</i> .
C653M-D	9/03	Revised <i>Important Safeguards and Warnings</i> to advise against interconnecting outputs. Revised table of models to show which ones have Class 2 outputs.

® Pelco, the Pelco logo, Spectra, Genex, Legacy, Esprit, and Camclosure are registered trademarks of Pelco.

© Copyright 2003, Pelco.
All rights reserved.

Free Manuals Download Website

<http://myh66.com>

<http://usermanuals.us>

<http://www.somanuals.com>

<http://www.4manuals.cc>

<http://www.manual-lib.com>

<http://www.404manual.com>

<http://www.luxmanual.com>

<http://aubethermostatmanual.com>

Golf course search by state

<http://golfingnear.com>

Email search by domain

<http://emailbydomain.com>

Auto manuals search

<http://auto.somanuals.com>

TV manuals search

<http://tv.somanuals.com>