



## C2224M-B (12/06) PMCL-WMT Monitor Mount

### Important Safety Instructions

1. Read these instructions.
2. Keep these instructions.
3. Heed all warnings.
4. Follow all instructions.
5. Installation should be done only by qualified personnel and conform to all local codes.
6. Only use installation methods and materials capable of supporting four times the maximum specified load.
7. Only use replacement parts recommended by Pelco.
8. This unit is designed for indoor use only, and it must not be installed where exposed to rain or moisture.

### Description

The PMCL-WMT is a tilt/swivel wall mount that can be used to mount any of Pelco's 200, 300, or 400 Series flat panel LCD monitors. This mount can also support most sizes of Pelco's 500 Series LCD monitors, although a PMCL-V200 adapter plate may be required. This mount can be swiveled 360 degrees to allow you to use the monitor in either landscape or portrait view. The mount also allows you to tilt the monitor 35 degrees for the best viewing angle. The PMCL-WMT is capable of supporting a maximum load of 90 pounds (40.8 kg).

### Installation

The following parts are supplied:

Qty	Description
1	Wall bracket
1	Monitor mount
4	M4 x 10 mm pan head Phillips screws, stainless steel
4	Split lock washers
4	M6 x 12 mm pan head Phillips screws, stainless steel
4	Flat washers
1	10-32 socket head screw
1	Flat washer, #10, stainless steel
1	Allen wrench, 3/16"
1	Allen wrench, 5/32"

To install the tilt/swivel wall mount:

1. Disassemble the monitor mount from the wall bracket by removing the 10-32 socket head screw and flat washer from the underside of the mount. Use the 5/32-inch Allen wrench (supplied) to loosen the screw. Slide the two pieces apart and retain the washer and screw for reassembly.
2. Attach the monitor mount to the monitor. Refer to Figure 1 and do one of the following:
  - **31-inch Monitor or Smaller:** Align the monitor to the correct hole pattern on the mounting plate. Use the M4 x 10 mm screws and split lock washers (supplied) to secure the monitor to the mounting plate.
  - or
  - **Monitors Larger than 31-inches:** Align the monitor to the outside hole pattern of the monitor plate. Use the M6 x 12 mm screws and flat washers (supplied) to secure the monitor to the mounting plate.

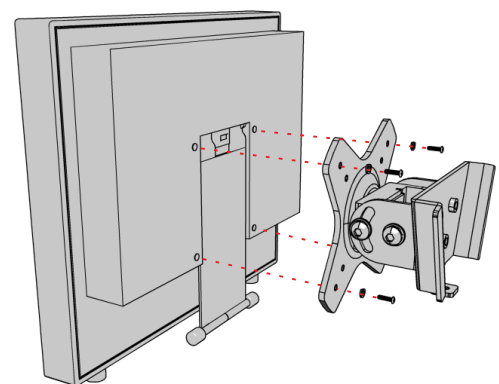


Figure 1. Attaching the Monitor Mount

3. Attach the wall bracket to the wall with the short side pointing down. Mounting hardware is not supplied.
  - a. If installing the mount to a wood stud wall, the stud must be at least 2 inches x 4 inches with a maximum 0.5-inch thick layer of wallboard or plywood. Use the following steps to attach the mount to a wood stud wall:
    - (1) Use a stud finder to locate and mark the edges of the wood stud that the mount will be attached to.
    - (2) Center two of the wall bracket mounting holes vertically between the edges of the wood stud. Use the wall bracket as a template to mark the two mounting holes.
    - (3) Attach the wall bracket to the wall and through the wood stud using two 1/4-inch diameter x 2-inch lag bolts as shown in Figure 2.
    - (4) Finish mounting the wall bracket to the wall. Insert hardware suitable for the mounting surface through the remaining two wall bracket mounting holes. Refer to the following chart for recommended installation surfaces and minimal hardware requirements.

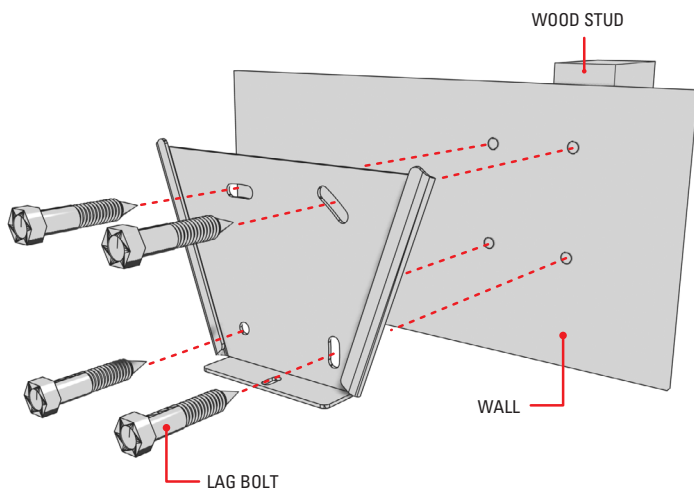
Recommended Mounting Surface	Recommended Hardware
Minimum 2-inch x 4-inch wood stud with maximum 0.5-inch thick wallboard	Two 1/4-inch diameter x 2-inch toggle bolts
Minimum 2-inch x 4-inch wood stud with maximum 0.5-inch thick plywood	Two 1/4-inch diameter x 2-inch lag bolts

- b. Use the following steps to attach the mount to a solid concrete or cinder block wall:
  - (1) Level and use the wall bracket as a template to mark the mounting holes on the wall.
  - (2) Attach the wall bracket to the wall using 1/4-inch diameter x 2-inch wedge anchors as shown in Figure 3.

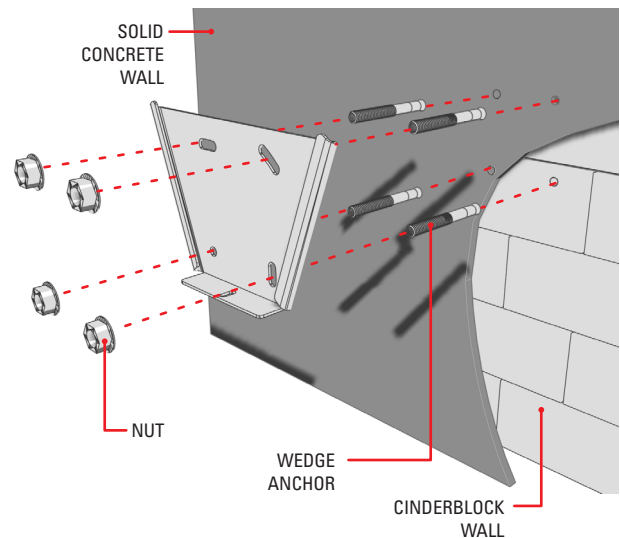
**WARNING:**

- Do not install hardware into mortar joints in filled or non-filled cinder block walls.
- Concrete must be a minimum of 3600 psi or 25 Mpa density.

- (1) Level and use the wall bracket as a template to mark the mounting holes on the wall.
- (2) Attach the wall bracket to the wall using 1/4-inch diameter x 2-inch wedge anchors as shown in Figure 3.

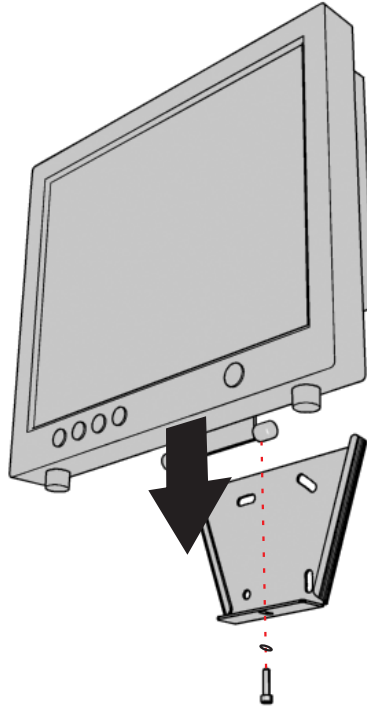


**Figure 2.** Attaching the Wall Bracket to Wood Stud Wall



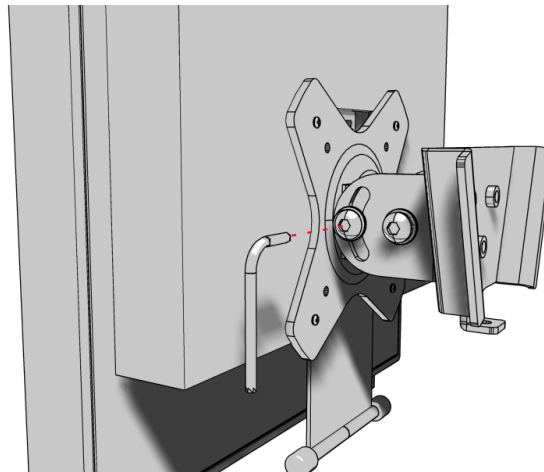
**Figure 3.** Attaching the Wall Bracket to Solid Concrete or Cinderblock Wall

- Carefully slide the monitor mount into the slots of the wall bracket. Use the 10-32 socket head screw and the flat washer (supplied) to fasten the wall bracket to the monitor mount. Refer to Figure 4. Use the 5/32-inch Allen wrench (supplied) to tighten the screw.




**Figure 4. Attaching the Wall Mount and Monitor**

- Using the 3/16-inch Allen wrench (supplied), loosen the button head bolts on the side of the mounting head. Tilt the monitor to the desired angle. To secure the monitor in place, retighten the button head bolts.



**Figure 5. Securing the Monitor**

- To swivel the monitor between portrait and landscape views, loosen the nut on the back side of the mounting head using a 9/16-inch wrench (not supplied). Retighten the nut to secure the monitor in place.

 The materials used in the manufacture of this document and its components are compliant to the requirements of Directive 2002/95/EC.

#### REVISION HISTORY

Manual #	Date	Comments
C2224M	8/06	Original version.
C2224M-A	11/06	Inserted statement per UL about minimum 2 x 4 wood stud.
C2224M-B	12/06	Added hardware information for large monitors per ECO 06-17078.

Pelco, the Pelco logo, Camclosure, Esprit, Genex, Legacy, and Spectra are registered trademarks of Pelco.  
Endura, ExSite, and Spectra III are trademarks of Pelco.  
DLP is a registered trademark of Texas Instruments, Inc.

©Copyright 2006, Pelco. All rights reserved.

## PRODUCT WARRANTY AND RETURN INFORMATION

### WARRANTY

Pelco will repair or replace, without charge, any merchandise proved defective in material or workmanship **for a period of one year** after the date of shipment.

Exceptions to this warranty are as noted below:

- Five years on FR/FT/FS Series fiber optic products and TW3000 Series unshielded twisted pair transmission products.
- Three years on Spectra® IV products.
- Three years on Genex® Series products (multiplexers, server, and keyboard).
- Three years on Camclosure® and fixed camera models, except the CC3701H-2, CC3701H-2X, CC3751H-2, CC3651H-2X, MC3651H-2, and MC3651H-2X camera models, which have a five-year warranty.
- Three years on PMCL200/300/400 Series LCD monitors.
- Two years on standard motorized or fixed focal length lenses.
- Two years on Legacy®, CM6700/CM6800/CM9700 Series matrix, and DF5/DF8 Series fixed dome products.
- Two years on Spectra III™, Esprit®, ExSite™, and PS20 scanners, including when used in continuous motion applications.
- Two years on Esprit and WW5700 Series window wiper (excluding wiper blades).
- Two years (except lamp and color wheel) on Digital Light Processing (DLP®) displays. The lamp and color wheel will be covered for a period of 90 days. The air filter is not covered under warranty.
- Eighteen months on DX Series digital video recorders, NVR300 Series network video recorders, and Endura™ Series distributed network-based video products.
- One year (except video heads) on video cassette recorders (VCRs). Video heads will be covered for a period of six months.
- Six months on all pan and tilts, scanners or preset lenses used in continuous motion applications (that is, preset scan, tour and auto scan modes).

Pelco will warrant all replacement parts and repairs for 90 days from the date of Pelco shipment. All goods requiring warranty repair shall be sent freight prepaid to Pelco, Clovis, California. Repairs made necessary by reason of misuse, alteration, normal wear, or accident are not covered under this warranty.

Pelco assumes no risk and shall be subject to no liability for damages or loss resulting from the specific use or application made of the Products. Pelco's liability for any claim, whether based on breach of contract, negligence, infringement of any rights of any party or product liability, relating to the Products shall not exceed the price paid by the Dealer to Pelco for such Products. In no event will Pelco be liable for any special, incidental or consequential damages (including loss of use, loss of profit and claims of third parties) however caused, whether by the negligence of Pelco or otherwise.

The above warranty provides the Dealer with specific legal rights. The Dealer may also have additional rights, which are subject to variation from state to state.

If a warranty repair is required, the Dealer must contact Pelco at (800) 289-9100 or (559) 292-1981 to obtain a Repair Authorization number (RA), and provide the following information:

1. Model and serial number
2. Date of shipment, P.O. number, Sales Order number, or Pelco invoice number
3. Details of the defect or problem

If there is a dispute regarding the warranty of a product which does not fall under the warranty conditions stated above, please include a written explanation with the product when returned.

Method of return shipment shall be the same or equal to the method by which the item was received by Pelco.

### RETURNS

In order to expedite parts returned to the factory for repair or credit, please call the factory at (800) 289-9100 or (559) 292-1981 to obtain an authorization number (CA number if returned for credit, and RA number if returned for repair).

All merchandise returned for credit may be subject to a 20% restocking and refurbishing charge.

Goods returned for repair or credit should be clearly identified with the assigned CA or RA number and freight should be prepaid. Ship to the appropriate address below.

*If you are located within the continental U.S., Alaska, Hawaii or Puerto Rico, send goods to:*

Service Department  
Pelco  
3500 Pelco Way  
Clovis, CA 93612-5699

*If you are located outside the continental U.S., Alaska, Hawaii or Puerto Rico and are instructed to return goods to the USA, you may do one of the following:*

If the goods are to be sent by a COURIER SERVICE, send the goods to:

Pelco  
3500 Pelco Way  
Clovis, CA 93612-5699 USA

If the goods are to be sent by a FREIGHT FORWARDER, send the goods to:

Pelco c/o Expeditors  
473 Eccles Avenue  
South San Francisco, CA 94080 USA  
Phone: 650-737-1700  
Fax: 650-737-0933



Worldwide Headquarters  
3500 Pelco Way  
Clovis, California 93612 USA

USA & Canada  
Tel: 800/289-9100  
Fax: 800/289-9150

International  
Tel: 1-559/292-1981  
Fax: 1-559/348-1120

[www.pelco.com](http://www.pelco.com)

ISO9001

Download from [Www.Somanuals.com](http://Www.Somanuals.com). All Manuals Search And Download.

## Free Manuals Download Website

<http://myh66.com>

<http://usermanuals.us>

<http://www.somanuals.com>

<http://www.4manuals.cc>

<http://www.manual-lib.com>

<http://www.404manual.com>

<http://www.luxmanual.com>

<http://aubethermostatmanual.com>

Golf course search by state

<http://golfingnear.com>

Email search by domain

<http://emailbydomain.com>

Auto manuals search

<http://auto.somanuals.com>

TV manuals search

<http://tv.somanuals.com>