

**MPT8000 Series
Wiretron Digital
Transmitter/
Controller and
WX8000 Series
Receiver/Driver**

**Installation/
Operation Manual**

C585M-B (11/98)

Pelco • 3500 Pelco Way, Clovis • CA 93612-5699 USA
In North America and Canada: Tel (800) 289-9100 or FAX (800) 289-9150
International Customers: Tel (1-559) 292-1981 or FAX (1-559) 348-1120

CONTENTS

Section	Page
1.0 GENERAL	5
1.1 IMPORTANT SAFEGUARDS AND WARNINGS	5
1.2 UNPACKING INSTRUCTIONS	6
1.3 RECOMMENDED TOOLS	6
2.0 DESCRIPTION	7
2.1 MODELS	7
2.1.1 Wiretron Digital Transmitter/Controller	7
2.1.2 Wiretron Receiver/Driver	8
2.2 CERTIFICATIONS	8
3.0 INSTALLATION	9
3.1 RECEIVER 24 VAC POWER INPUT MODIFICATION	10
3.2 MOUNTING	12
3.2.1 Transmitter/Controller	12
3.2.2 Receiver	12
3.3 WIRING	12
3.3.1 Control Wiring	12
3.3.1.1 Wiring the Transmitter/Controller to the Receiver ..	12
3.3.1.2 Wiring from the Receiver/Driver to the Pan/Tilt	13
3.3.2 Auxiliary Functions	16
3.3.3 Video Wiring	16
3.3.3.1 Long Distance Cable Installation	18
3.4 POWER	19
4.0 OPERATION	21
4.1 AUTO/RANDOM OPERATION	21
5.0 MAINTENANCE	22
6.0 TROUBLESHOOTING	22
6.1 RECEIVER PIN ASSIGNMENTS	23
7.0 SPECIFICATIONS	24
8.0 WARRANTY AND RETURN INFORMATION	28

LIST OF ILLUSTRATIONS

Figure		Page
1	Basic Wiretron System Configuration	9
2	Multiple Camera Wiretron System	9
3	Circuit Board Electrical Connections	10
4	24 VAC Power Input Modification Diagram	11
5	Basic Wiretron Interconnect Diagram	13
6	Connector Assembly	14
7	Receiver Control Output/Input Pin Assignments	15
8	Jumper Settings on the Receiver Circuit Board	16
9	Auxiliary Functions Wiring Diagram	17
10	External Device Wiring Diagram	17
11	Receiver Pin Assignments	23
12	MPT8000 Series Controller Dimension Drawing	25
13	WX8000 Series Receiver Dimension Drawing (Outdoor Models)	27
14	WX8000 Series Receiver Dimension Drawing (Indoor Models)	27

LIST OF TABLES

Table		Page
A	Control Cable Wiring Distances	12
B	Video Coaxial Cable Wiring Distances	20
C	24 VAC Wiring Distances	20

REVISION HISTORY

Manual #	Date	Comments
C585M	1985	Original version.
C585M-A	4/90	Rev A. Revised manual to include instructions on converting the WX802RX and WX8024RXI receiver/ drivers to operate on 24 VAC input voltage.
C585M-B	11/98	Rev B. Changed manual to new format. Completely revised installation and operation instructions, and added agency compliance certifications.

(This page intentionally left blank.)

1.0 GENERAL

1.1 IMPORTANT SAFEGUARDS AND WARNINGS

Prior to installation and use of this product, the following WARNINGS should be observed.

1. Installation and servicing should only be done by qualified service personnel and conform to all local codes.
2. Unless the unit is specifically marked as a NEMA Type 3, 3R, 3S, 4, 4X, 6, or 6P enclosure, it is designed for indoor use only and it must not be installed where exposed to rain and moisture.
3. Only use replacement parts recommended by Pelco.
4. After replacement/repair of this unit's electrical components, conduct a resistance measurement between line and exposed parts to verify the exposed parts have not been connected to line circuitry.

The product and/or manual may bear the following marks:



This symbol indicates that dangerous voltage constituting a risk of electric shock is present within this unit.



This symbol indicates that there are important operating and maintenance instructions in the literature accompanying this unit.

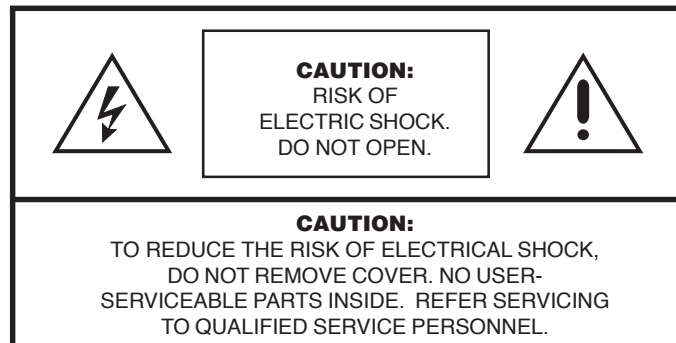

Please thoroughly familiarize yourself with the information in this manual prior to installation and operation.

1.2 UNPACKING INSTRUCTIONS

Unpack and inspect all parts carefully.

The following items are supplied:

- 1 MPT8000 Series Wiretron Controller
- or
- 1 WX8000 Series Receiver/Driver
- 1 Installation/Operation Manual (C585M-B)

Be sure to save the shipping carton, boxes and inserts. They are the safest materials in which to make future shipments.

If an item appears to have been damaged in shipment, replace it properly in its box and contact the factory at 1-800-289-9100 or 1-559-292-1981 for a replacement. (International customers fax 1-559-348-1120 for authorization and instructions.)

If an item needs to be returned to the factory for repair, consult the WARRANTY AND RETURN INFORMATION section of this manual for instructions.

1.3 RECOMMENDED TOOLS

Pelco does not supply the basic tools needed for the installation process. The following tools are recommended.

- Wire stripper
- Wire cutter
- AMP type crimper
- Medium Phillips screwdriver
- Power drill

2.0 DESCRIPTION

The Wiretron digital control system operates over a two-conductor cable and controls CCTV equipment such as pan/tilts, enclosures, and motorized zoom lenses from a remote location up to 10 miles (16 km) away.

Wiretron can be configured to control a single site or interfaced with Pelco video switching equipment to provide a convenient video/control system with multiple control sites and/or multiple camera sites.

The Wiretron control system provides up to 15 remote control functions:

- | | |
|---------------|-------------------------|
| 1. Pan Left | 9. Iris Open |
| 2. Pan Right | 10. Iris Close |
| 3. Tilt Up | 11. Auto/Manual Scan |
| 4. Tilt Down | 12. Aux 1 (Manual Iris) |
| 5. Zoom In | 13. Aux 2 (Auto Iris) |
| 6. Zoom Out | 14. Aux 3 |
| 7. Focus Near | 15. Aux 4 |
| 8. Focus Far | |

Functions 1 through 10 are momentary; that is, they are actuated only while the associated control switch is operated. Function 11 is latching; that is, auto scan remains on until turned off. Aux 1, 2, 3, and 4 are low power outputs that may be used to control such things as lights and gates. More auxiliary power output is available when the controller is used with the AUX2000 Auxiliary Control Box. Aux 1-4 are jumper selectable for momentary/latching operation.

Functions 1 through 10 can be operated simultaneously. Functions 11 through 15 must be used individually, although any one of these functions may be used simultaneously with functions 1 through 10.

Wiretron provides the following standard functions on a single circuit board and chassis with integral power supply:

1. Pan/tilt (24 VAC or 120 VAC as ordered from the factory)
2. Zoom lens—zoom, iris, focus with adjustable speed (speed not remotely controllable)
3. Camera power (24 VAC or 120 VAC as ordered from the factory)
4. An open collector transistor output (latching) for use in the manual override of an automatic iris control

Wiretron is designed to combat erroneous control and execution by providing the following protective functions:

1. Simultaneous commands from two different sources are processed to ensure that manual iris control cannot be inadvertently selected in place of automatic control.
2. A sustained (20-to-40 second) illegal command condition results in the following:
 - a. Automatic iris
 - b. Manual pan

2.1 MODELS

2.1.1 Wiretron Digital Transmitter/Controller

MPT8000CZ	Desktop Wiretron transmitter/controller with pan/tilt joystick and zoom lens control, 120 VAC input.
MPT8000CZ/220	Same as MPT8000CZ except 230 VAC input

2.1.2 Wiretron Receiver/Driver

Outdoor

WX8024RX	Wiretron receiver in weatherproof box for 24 VAC pan/tilts with power supply for pan/ tilt, zoom lens, 24 VAC camera power, 120 VAC input
WX8024RX/220	Same as WX8024RX except 230 VAC input
WX8115RX	Wiretron receiver in weatherproof box for 120 VAC pan/tilts with power supply for pan/ tilt, zoom lens, 120 VAC camera power, 120 VAC input
WX8220RX	Same as WX8115RX except 230 VAC input, 230 VAC pan/tilt output
WX8224RX	Same as WX8024RX except 24 VAC input

Indoor

WX8024RXI	Same as WX8024RX except for indoor use, 120 VAC input
WX8024RXI/220	Same as WX8024RXI except 230 VAC input
WX8224RXI	Same as WX8024RXI except 24 VAC input

2.2 CERTIFICATIONS

The products identified below have been tested and certified for agency compliance as noted.

Wiretron Digital Controller

Model	Agency Compliance Certification			
	CE	FCC	UL	CSA/cUL
MPT8000CZ			X	
MPT8000CZ/220				

Applicable CE, FCC, UL, and CSA/cUL standards:

- UL Standard 2044

Additional applicable standards:

- NEMA Type 1
- IP 20

Wiretron Receiver/Driver

Model	Agency Compliance Certification			
	CE	FCC	UL	CSA/cUL
Outdoor				
WX8024RX			X	
WX8024RX/220				
WX8115RX			X	
WX8220RX				
WX8224RX			X	
Indoor				
WX8024RXI			X	
WX8024RXI/220				
WX8224RXI			X	

Applicable CE, FCC, UL, and CSA/cUL standards:

- UL Standard 2044

Additional applicable standards:

- NEMA Type 1 (RXI models)
- NEMA Type 4 (WX8024RX/220; WX8024RXI/220; WX8220RX)
- NEMA Type 4X (WX8024RX; WX8115RX; WX8224RX)
- IP 20 (RXI models)
- IP 56 (RX models)

3.0 INSTALLATION

The simplest Wiretron system, consisting of the control transmitter and receiver, is shown in Figure 1. Up to 15 control functions are transmitted over the transmission line to the remotely located receiver. These signals are then converted to drive voltages or relay switching for auxiliary equipment being controlled. The basic system can be expanded to control multiple camera sites with the addition of a manual video switcher with balanced audio follow (BAF), as shown in Figure 2.

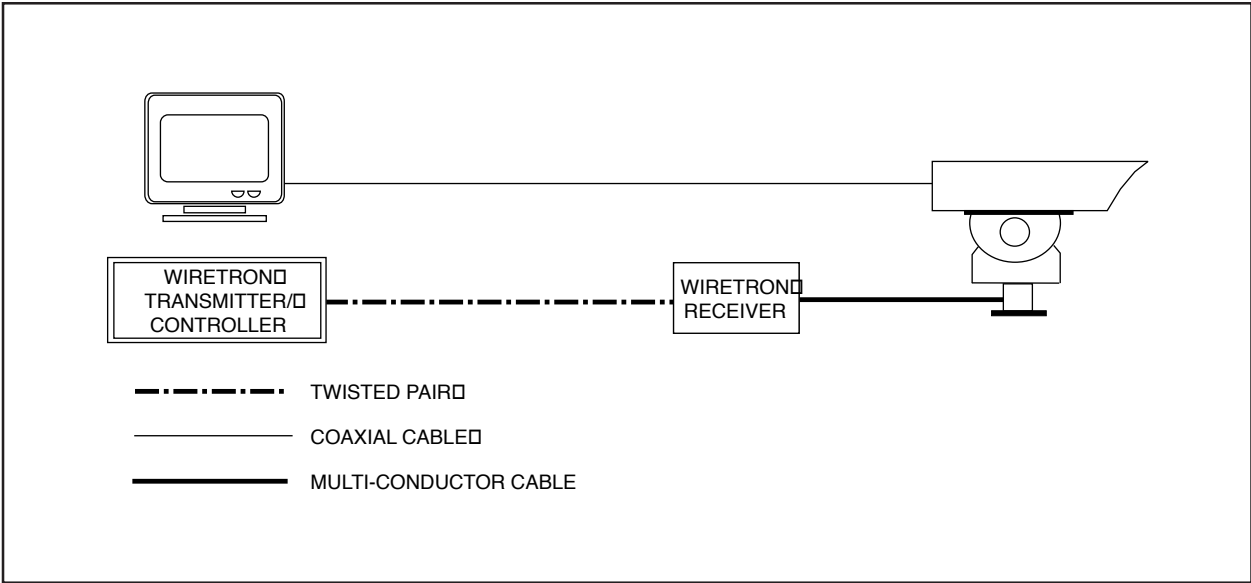

Figure 1. Basic Wiretron System Configuration

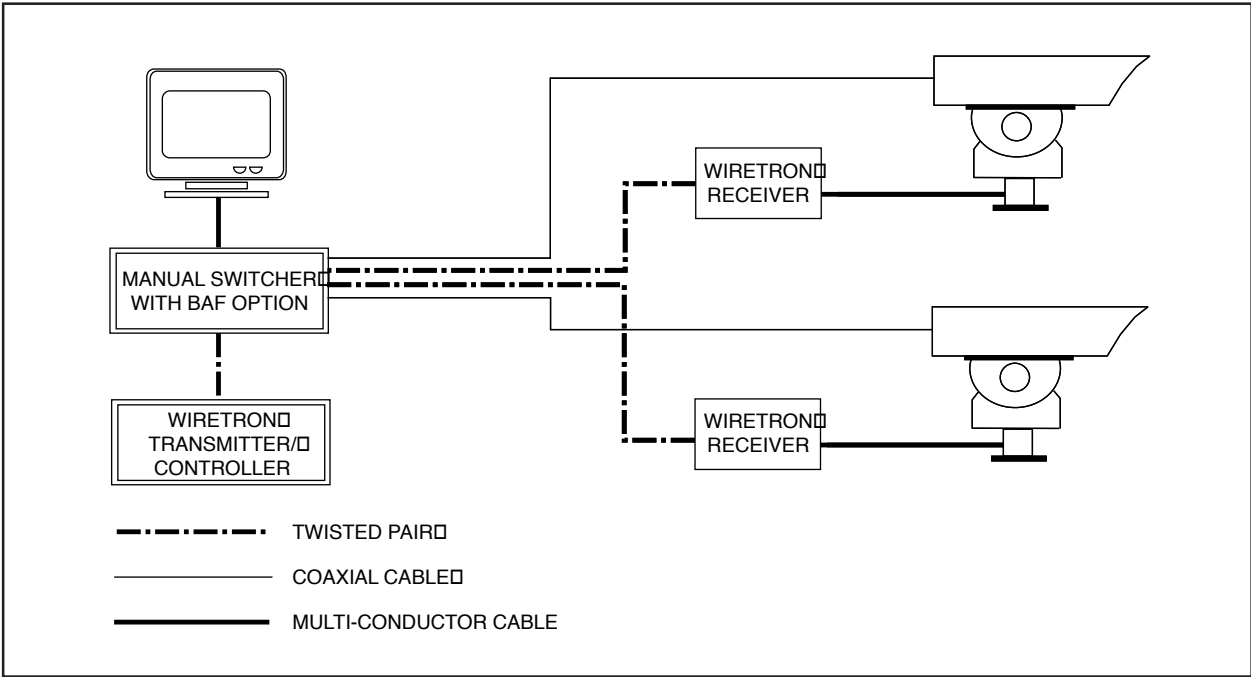

Figure 2. Multiple Camera Wiretron System

3.1 RECEIVER 24 VAC POWER INPUT MODIFICATION

The WX8024RX series receivers can be converted to operate with 24 VAC input.

To convert the receiver, disconnect the receiver circuit board and assembly from the enclosure. The patch panel circuit board is located on the bottom of the receiver circuit board mounting plate and requires the following modifications for 24 VAC operation (refer to Figures 3 and 4.)

NOTE: Parts needed for modification: one 3 A fuse for F3.



WARNING: High voltage is present on the T3 transformer wires when the unit is connected to power. Be sure the wires are insulated for safety.

NOTE: When operating with 24 VAC input power, the distance from the receiver to the 24 VAC power supply is typically limited to any conductor size/length combination resulting in less than 5 ohms total circuit resistance.

1. Turn off the power to the receiver and remove the power cord.
2. Remove all wires from patch panel sections T2 and T3 with the exception of the red wire connected to T3-1 and the red/white wire connected to T3-3.
3. Remove jumper wires from J4 pins 8 and 9 and J5 pins 8 and 9.
4. Remove transformer T2 (small transformer) and store for future use or discard.
5. On transformer T3 (large transformer), insulate the wire ends on the black, brown, black/white and brown/white wires.
6. Locate the blue wire connecting fuse F3 to pin 7 of P7 (labeled F3) and disconnect at the P7 location. Reconnect to T3-3.
7. Connect a jumper from J4 pin 9 to T3-1.
8. Locate the wire connecting fuse F2 to pin 6 of P7 (labeled F2) and disconnect at the P7 location. Reconnect to T2-3.
9. Connect a jumper from J5 pin 9 to T2-1.
10. Change fuse F2 from 2/10 ASB to 1 AG.
11. Change fuse F3 from 1 ASB to 3 AG.

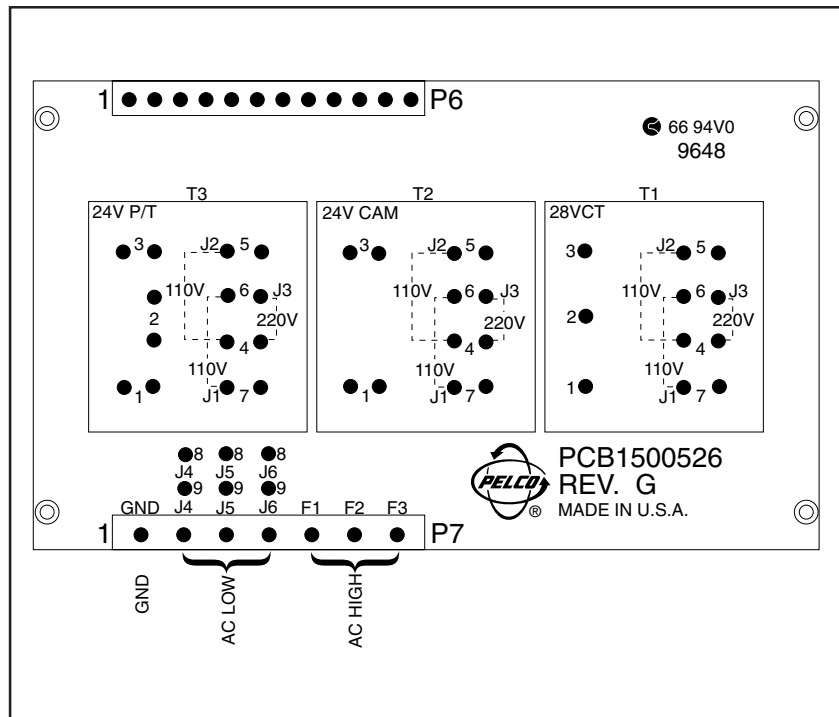

Figure 3. Circuit Board Electrical Connections

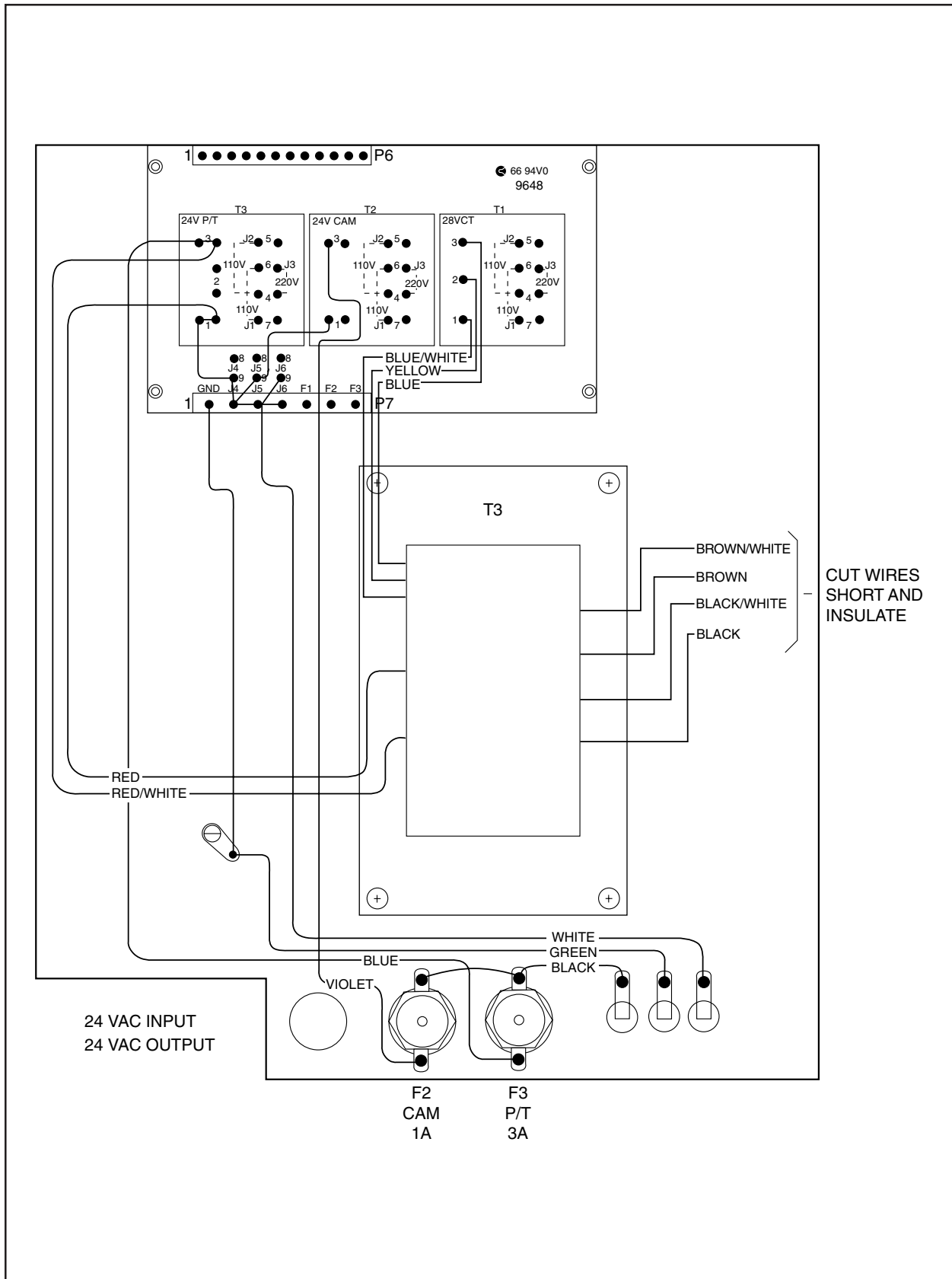

Figure 4. 24 VAC Power Input Modification Diagram

3.2 MOUNTING

3.2.1 Transmitter/Controller

NOTE: Never mount the receiver with wiring connectors facing up. Always have the connectors facing down to prevent water damage.

Transmitter/controllers in the MPT8000 Series are desktop units. Determine the best location for the unit.

Proceed to Section 3.2.2, RECEIVER.

3.2.2 Receiver

NOTE: When installing the WX8000 receiver to a wall outdoors, seal the bolt holes with an appropriate sealant. Apply the sealant around the bolt holes between the unit and the mounting surface. This will prevent possible water damage to the wall caused by rainwater leaking through the mounting bolt holes. (This may only be a problem when the mounting bolts go completely through the wall.)

1. Determine the best location to install the unit.
2. Using the WX8000 receiver box as a template, mark the hole pattern on the mounting surface. Drill holes in the mounting surface.
3. Attach the WX8000 receiver securely with four fasteners of appropriate length (not supplied.)

Proceed to Section 3.3, WIRING.

3.3 WIRING

3.3.1 Control Wiring

3.3.1.1 Wiring the Transmitter/Controller to the Receiver

Run the control cable between the controller/transmitter and the receiver (refer to Figures 1 and 2.)

The control cable should be unshielded twisted pair wire. Maximum operating distances should be determined by referring to Table A, Control Cable Wiring Distances.

Table A. Control Cable Wiring Distances

Wire Gauge*	Maximum Distance
22 AWG	5 miles (8 km)
20 AWG	10 miles (16 km)

* Control cable operating distances are approximate according to wire used.

To wire the MPT8000 control wires, refer to Figure 5 and perform the following instructions:

1. Attach one wire from the terminal labeled HI on the MPT8000 Series controller to the terminal labeled HI on the WX8000 Series receiver.
2. Attach one wire from the terminal labeled LOW on the MPT8000 Series controller to the terminal labeled LOW on the WX8000 Series receiver.

If you want to use a configuration that includes a switching device, refer to the manual provided with the switcher for the appropriate connections.

Proceed to Section 3.3.1.2, WIRING FROM THE RECEIVER/DRIVER TO THE PAN/TILT.

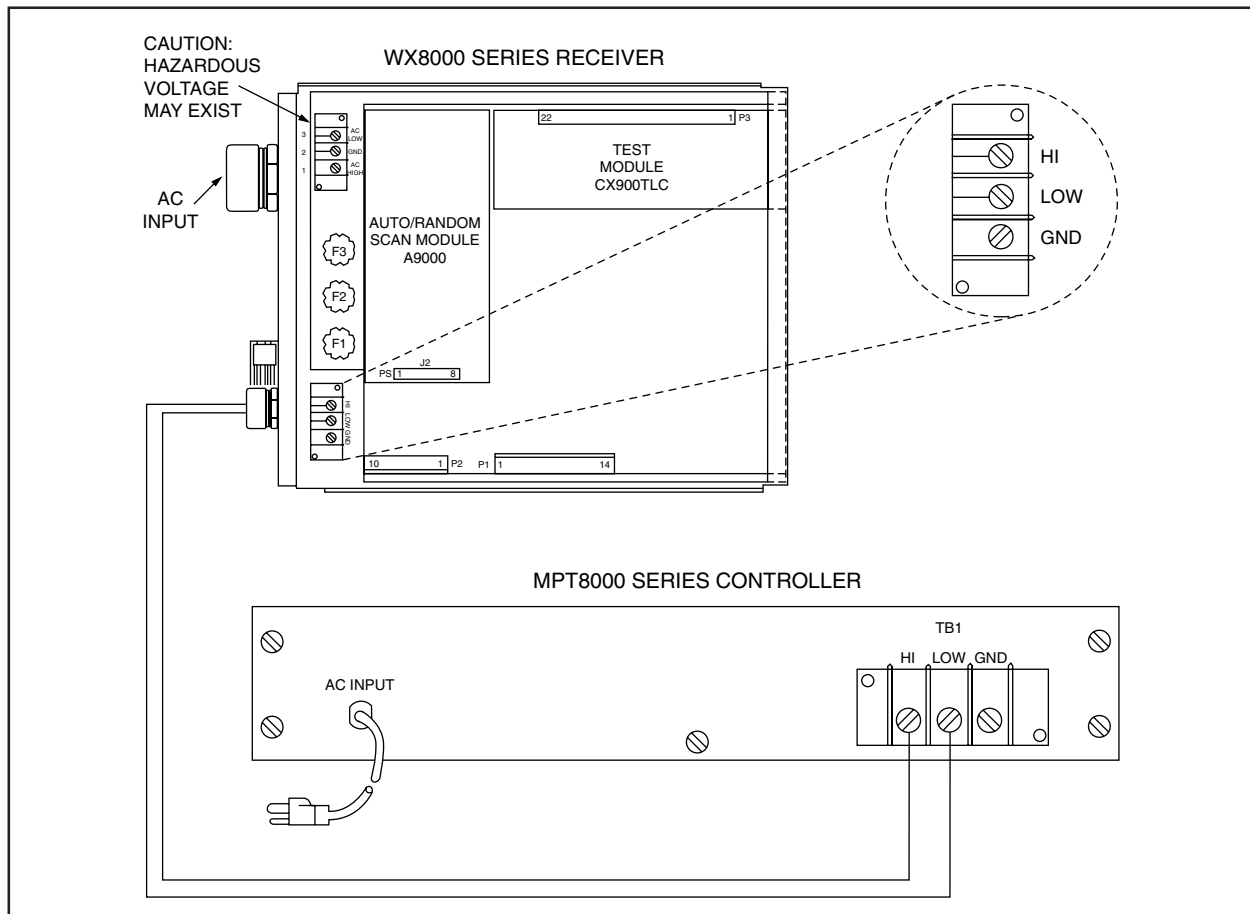

Figure 5. Basic Wiretron Interconnect Diagram

3.3.1.2 Wiring from the Receiver/Driver to the Pan/Tilt

1. Run multi-conductor cable between the receiver/driver and the pan/tilt (refer to Figures 1 and 2.)
2. Assemble the connector parts according to the following instructions. Detail B, in Figure 6, reflects the pin arrangement specific to the WX8000 Series receiver/drivers. Refer to Figures 6 and 7 during assembly. For best results, use an AMP style crimper when making the wire-to-pin connection.

The instructions that follow apply to all AMP style connectors regardless of pin size or pin number.

1. Slide the connector clamp assembly over the conductor cable. If the diameter of the conductor cable is such that the rubber boot will slide over it easily then slide the rubber boot onto the conductor cable at this time. If not, discard the rubber boot.
2. Prepare the wires from the conductor cable as follows:
 - a. Strip at least 1-inch (2.54 cm) from the cable jacket to expose the wires. You may need to strip more from the cable jacket if you have more wires.
 - b. Strip 1/8-inch (0.318 cm) from each wire.
 - c. Using an AMP style crimper, crimp the wires and their insulation to the connector pins. Refer to Detail A in Figure 6.

3. Slide the connector pins into the appropriate holes in the connector body until they snap into place. Refer to Figures 4 and 5 for correct pin arrangement, depending on model and options.
4. Push the connector clamp assembly (with boot, if used) toward the connector body. Screw the clamp assembly onto the connector body, being careful not to disturb the wires.
5. To complete the assembly, attach the appropriate clamp with the screws provided and tighten.
6. When you are finished wiring the connector, connect the 37-pin assembly to the WX8000 Series receiver/driver and the pan/tilt.

Proceed to Section 3.3.2, AUXILIARY FUNCTIONS.

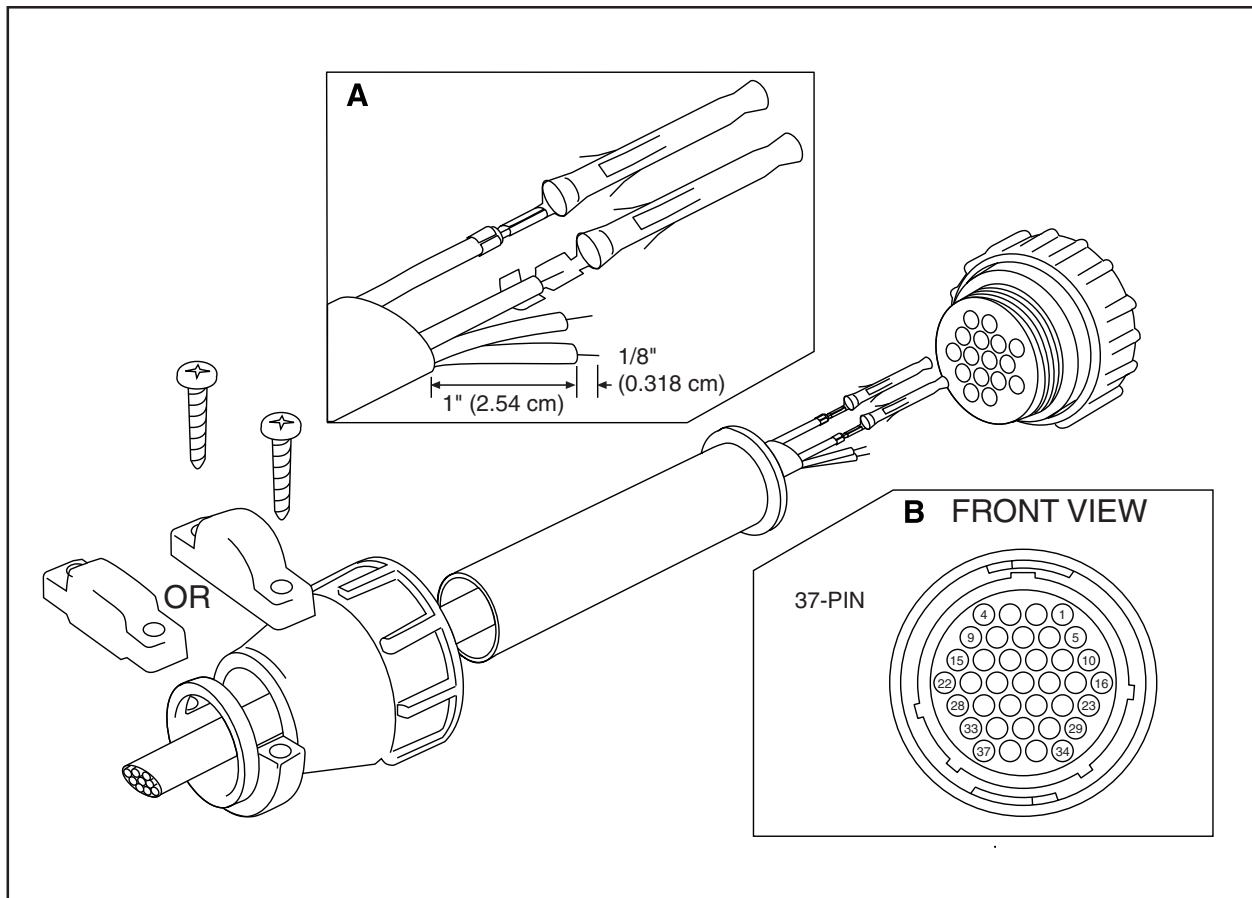

Figure 6. Connector Assembly

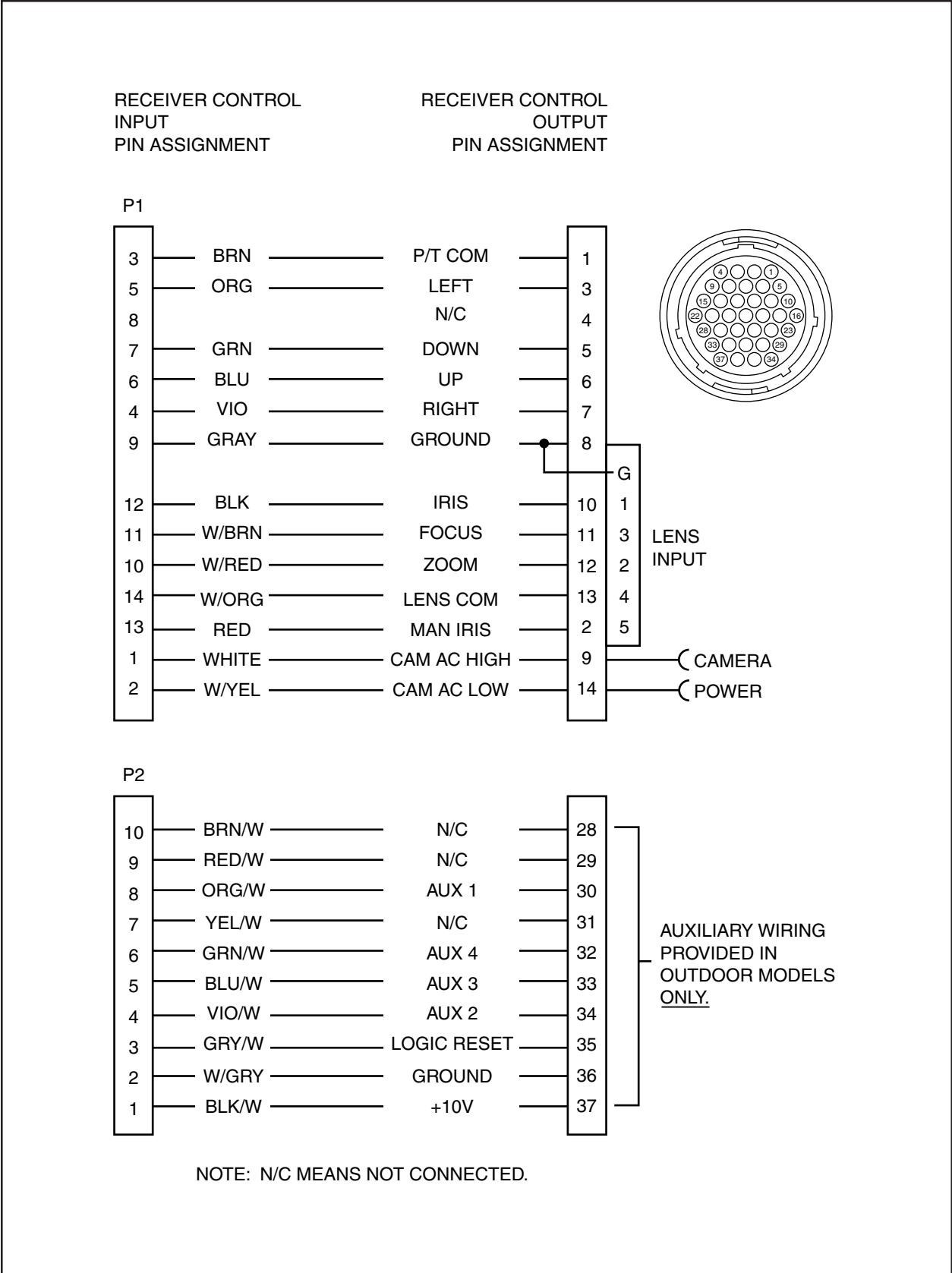

Figure 7. Receiver Control Output/Input Pin Assignments



WARNING: Mechanical relays used must not exceed 10 VDC at 25 mA. Applications with higher power requirements should be used with the AUX2000 Auxiliary Control Box. Refer to the AUX2000 manual for installation and operation instructions.

3.3.2 Auxiliary Functions

The Wiretron receiver is capable of operating up to four remotely activated auxiliary functions. Each auxiliary output may be individually converted at the receiver for momentary or latching operation. Refer to Figure 8 to set jumpers for auxiliary functions. When in the latching mode, activating the same AUX function will toggle the function from on to off.

The AUX outputs are buffered to provide a continuous 10 VDC at 25 mA to drive small relays, lights or other external devices such as gates. Refer to Figures 9 and 10 for examples of typical circuits used for auxiliary functions.

Proceed to Section 3.3.3, VIDEO WIRING.

3.3.3 Video Wiring

Install a video cable from the video output of the camera to the video input of the monitor (refer to Figures 1 and 2.) Proper termination of the video cable is vital to the operation of the equipment. Be sure 75-ohm cable termination is made at the monitor. Refer to Table B when wiring video coaxial cable distances up to 1,500 ft (457 meters).

Proceed to Section 3.4, POWER, if finished wiring video.

Proceed to Section 3.3.3.1, LONG DISTANCE CABLE INSTALLATION, when wiring longer distances.

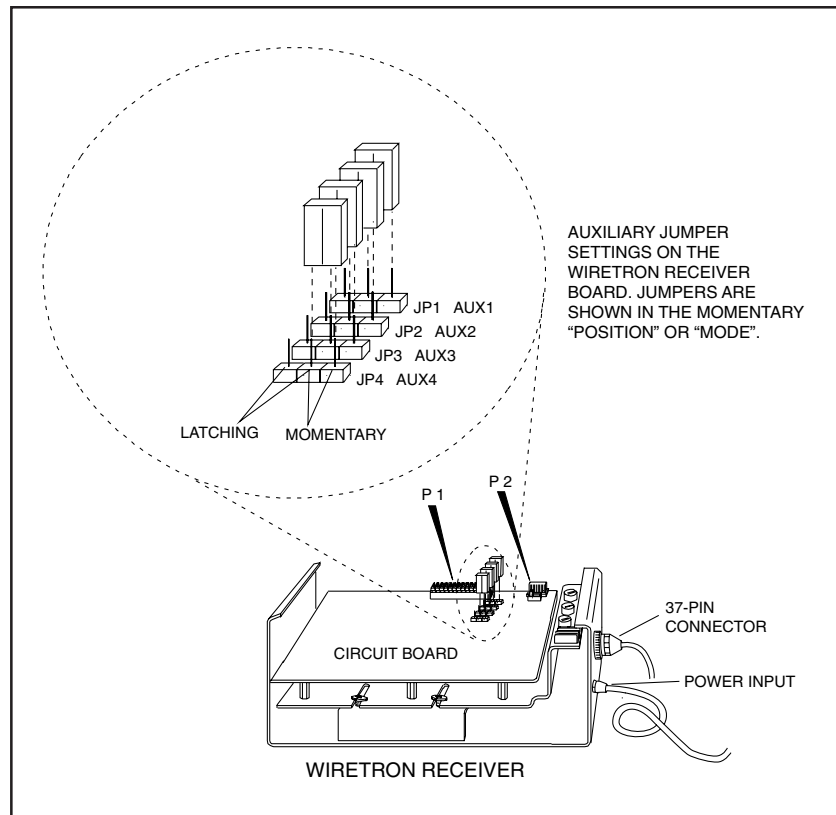

Figure 8. Jumper Settings on the Receiver Circuit Board

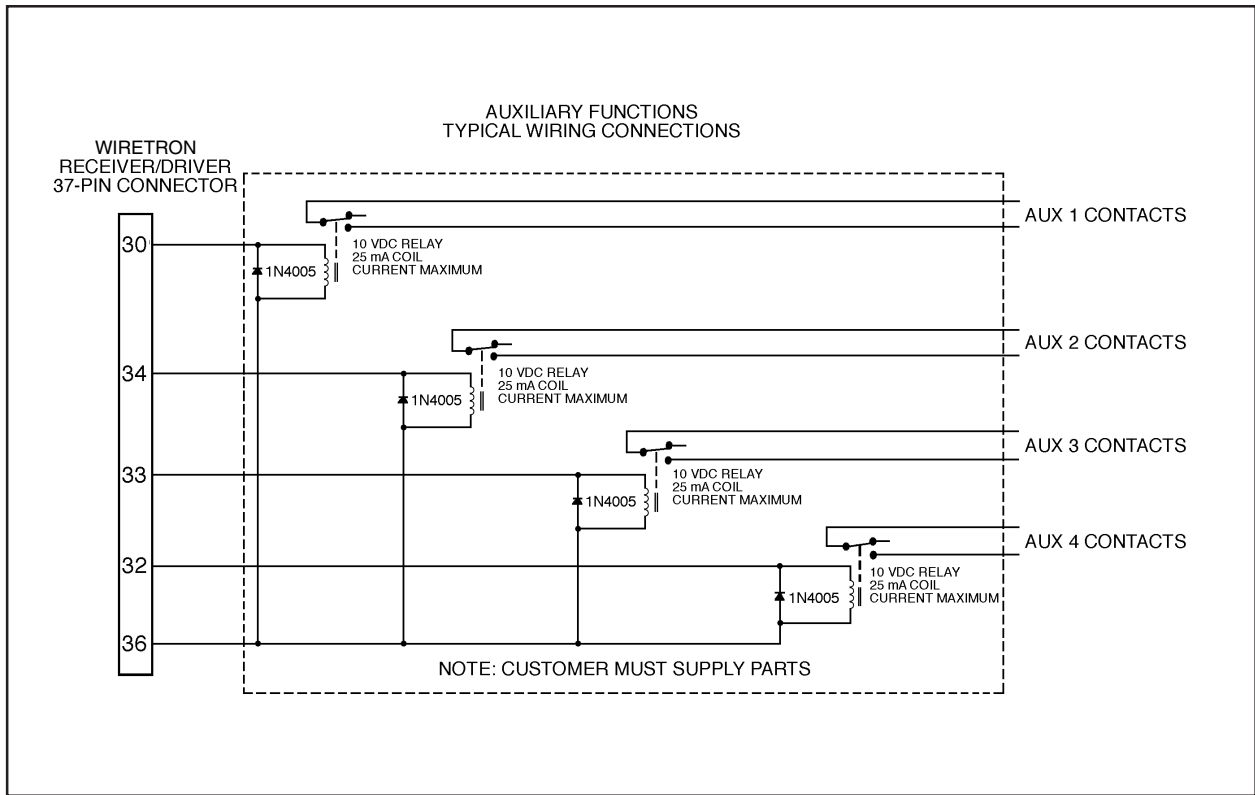

Figure 9. Auxiliary Functions Wiring Diagram

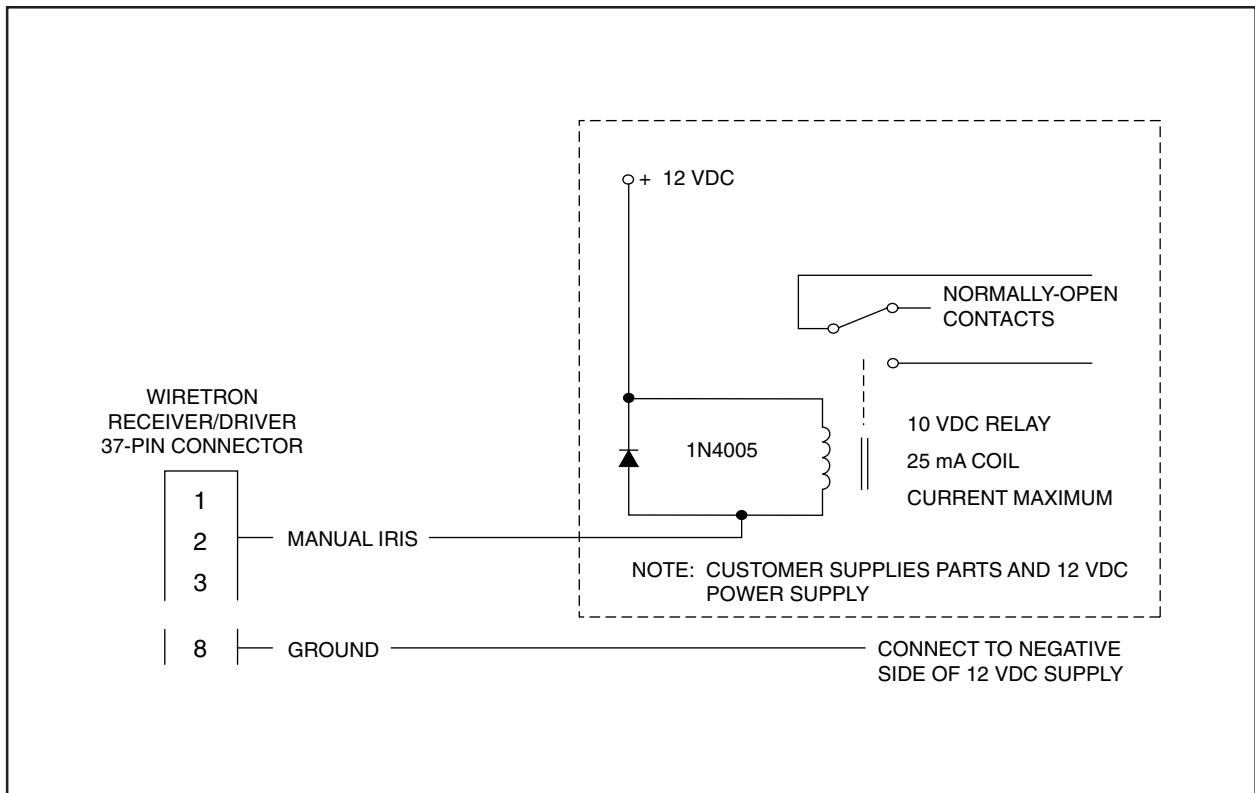

Figure 10. External Device Wiring Diagram

3.3.3.1 Long Distance Cable Installation

Because of the many options available, long distance video wiring is at your discretion. Review the following to determine the best method of wiring video for your application.

Maximum Distance Recommendations for Coaxial Cable

There are a number of variables to consider when specifying the type of coaxial cable to run. It is best to avoid the use of video amplifiers. Video amplifiers should be regarded as a remedy for an existing problem not as an installation aid.

Coaxial Splicing

Although not recommended, a splice in a coaxial cable is sometimes unavoidable in long runs or difficult conduit pulls. A female-to-male BNC splice is the first choice when splicing coaxial cable. An acceptable substitute is female-to-female with a barrel adapter (although there is more signal loss inherent in this type of splice.) The use of "F" connectors or barrels is not preferable because of the inferior mechanical connections and poor signal transmission characteristics inherent in those connectors.

Direct Burial

Direct burial cabling should only be used when the cabling is specifically rated for direct-burial use. Dig trenches and lay cable to a sufficient depth to accommodate climate and other conditions and local codes. Protect cabling from damage that may result from backfilling, traffic, burrowing animals, trenching, and other conditions.

Underground Conduit

Ensure that the cable is appropriate for use in underground conduit. Direct burial cable is usually not acceptable for use inside a buried conduit that may fill with water. Direct burial type of cable utilizes the earth surrounding the cable to wick moisture away from the cable. Call your cable supplier or manufacturer for their recommendations on the correct type of cable to use in circumstances where the cable will be used in conduit.

One-inch PVC is the minimum recommended size for underground conduits. Allow no more than two 90-degree bends between pull boxes. Make sure pull boxes and/or splice boxes are as water-resistant as possible and that splices stay above any water accumulation.

When using PVC, be sure to separate high voltage carrying conduits from video conduits by enough distance to ensure that the video signal is not degraded. When dealing with 120 VAC, about 12 inches of separation should be sufficient.

Aerial Spans

In some applications, it is preferable to run cable to a location overhead. If you want to use existing poles consult with the owners, warrantors, or maintaining entities. The poles may not be available for your use if the poles are owned by a public service, utility, or cable TV provider.

If poles are in use by others, make sure that the addition of your cable and wire complies with local codes and regulations. Proper spacing from existing wire and cable, the descending order of voltage-carrying cable, and the minimum low-clearance specifications over roads, alleys, and driveways etc. should be maintained.

Be aware of electrical inference that might be generated by high-voltage cables sharing the poles with the video cabling. Legal spacing may not be enough to prevent electrical inference if radiated levels are high.

Hardware on poles should be appropriate to sustain the weight and stress of the cable during adverse weather conditions.

Microwave

The WX8000 Series is excellent for microwave control. Consult with microwave equipment manufacturers and/or suppliers for recommendations regarding operating specifications, and installation.

Fiber Optic Cabling

Fiber optic transmission of both video and control presents some distinct advantages. Higher quality and longer distance transmission characteristics, inherent noise resistance, greater flexibility for usage, and reduced cabling diameter are but a few of these advantages. The incorporation of fiber optics systems are encouraged, especially when covering long distances and when seeking to maintain the highest quality video signals. Consult with equipment manufacturers and fiber optic cabling manufacturers or suppliers for recommendations regarding fiber optic type, operating specifications, and installation requirements.

Proceed to Section 3.4, POWER.

3.4 POWER

1. Run wiring and connect receiver input power to AC HIGH, AC LOW, and ground. If using 24 VAC to power the receiver, refer to Table C for the maximum recommended wiring distances.
2. Power up the controller and receiver.

Table B. Video Coaxial Cable Wiring Distances

Cable Type*	Maximum Distance
RG59/U	750 ft (229 m)
RG6/U	1,000 ft (305 m)
RG11/U	1,500 ft (457 m)

*Minimum cable requirements:
 75 ohms impedance
 All-copper center conductor
 All-copper braided shield with 95% braid coverage

Table C. 24 VAC Wiring Distances

The following are the recommended maximum distances for 24 VAC applications and are calculated with a 10-percent voltage drop. (Ten percent is generally the maximum allowable voltage drop for AC-powered devices.)

EXAMPLE: An enclosure that requires 80 vA and is installed 35 feet (10 m) from the transformer would require a minimum wire gauge of 20 AWG.

NOTE: Distances are calculated in feet; values in parentheses are meters.

		Wire Gauge					
		20	18	16	14	12	10
Total vA consumed	10	283 (86)	451 (137)	716 (218)	1142 (348)	1811 (551)	2880 (877)
	20	141 (42)	225 (68)	358 (109)	571 (174)	905 (275)	1440 (438)
	30	94 (28)	150 (45)	238 (72)	380 (115)	603 (183)	960 (292)
	40	70 (21)	112 (34)	179 (54)	285 (86)	452 (137)	720 (219)
	50	56 (17)	90 (27)	143 (43)	228 (69)	362 (110)	576 (175)
	60	47 (14)	75 (22)	119 (36)	190 (57)	301 (91)	480 (146)
	70	40 (12)	64 (19)	102 (31)	163 (49)	258 (78)	411 (125)
	80	35 (10)	56 (17)	89 (27)	142 (43)	226 (68)	360 (109)
	90	31 (9)	50 (15)	79 (24)	126 (38)	201 (61)	320 (97)
	100	28 (8)	45 (13)	71 (21)	114 (34)	181 (55)	288 (87)
	110	25 (7)	41 (12)	65 (19)	103 (31)	164 (49)	261 (79)
	120	23 (7)	37 (11)	59 (17)	95 (28)	150 (45)	240 (73)
	130	21 (6)	34 (10)	55 (16)	87 (26)	139 (42)	221 (67)
	140	20 (6)	32 (9)	51 (15)	81 (24)	129 (39)	205 (62)
	150	18 (5)	30 (9)	47 (14)	76 (23)	120 (36)	192 (58)
	160	17 (5)	28 (8)	44 (13)	71 (21)	113 (34)	180 (54)
	170	16 (4)	26 (7)	42 (12)	67 (20)	106 (32)	169 (51)
	180	15 (4)	25 (7)	39 (11)	63 (19)	100 (30)	160 (48)
	190	14 (4)	23 (7)	37 (11)	60 (18)	95 (28)	151 (46)
	200	14 (4)	22 (6)	35 (10)	57 (17)	90 (27)	144 (43)
		Maximum distance from transformer to load					

4.0 OPERATION

In general, all controller operating controls are self-explanatory. All controls, except the ON/OFF power switch, are center-off, spring return switches (momentary on-off-momentary on.)

When using Aux 1-4 in the latching mode, operating the switch once will latch the function and operating it again will unlatch the function.

The camera on/off switch is non-functional; the receiver is permanently in the ON condition.

Reset causes latching functions to revert to the following:

1. Manual scan
2. Automatic iris

4.1 AUTO/RANDOM OPERATION

Auto scan and random scan modes are available when the A9000 Auto/Random Scan plug-in module is installed in the Wiretron receiver. This module, when used with the MPT8000 Series controller, allows control of pan and tilts. Refer to the A9000 manual for installation and operation instructions.

Advantages of random scan:

1. Because the scan direction, scan period, and dwell period are unpredictable, unauthorized activities or intrusions are discouraged.
2. Because of the reduced duty cycle, gear train wear, cable fatigue, drive motor wear, and temperature rise are reduced. These factors contribute to system reliability and increased equipment life.

5.0 MAINTENANCE

Regularly scheduled maintenance is not required. Clean the outer surface of the controller or receiver with a non-abrasive cleaning cloth and antistatic cleaner. Do not use kerosene or similar substances that may damage the surface.

6.0 TROUBLESHOOTING

If you experience operating problems with either the controller or receiver, first check all fuses and voltage readings to make sure they are in working order.

Auxiliary Functions

Aux 1, 2, 3, and 4 are low power outputs that may be used to control such things as lights and gates. More auxiliary power output is available when the controller is used with the AUX2000 Auxiliary Control Box. Refer to the AUX2000 manual for installation and operation instructions.

CX900TLC Manual Test Module

The CX900TLC Manual Test Module can be used to verify the receiver functions and accessories are operational. The CX900TLC is a dual-purpose plug-in module that permits local operation of all functions directly from the receiver unit, and serves to verify that the receiver and accessories are operating properly by providing visual confirmation. This module also aids in troubleshooting receiver or controller operational problems. Refer to the CX900TLC manual for installation and operation instructions.

Also refer to Figure 11 for troubleshooting information.

For additional troubleshooting information contact your local dealer or Pelco.

6.1 Receiver Pin Assignments

Refer to Figure 11, Receiver Pin Assignments, when servicing the receiver.

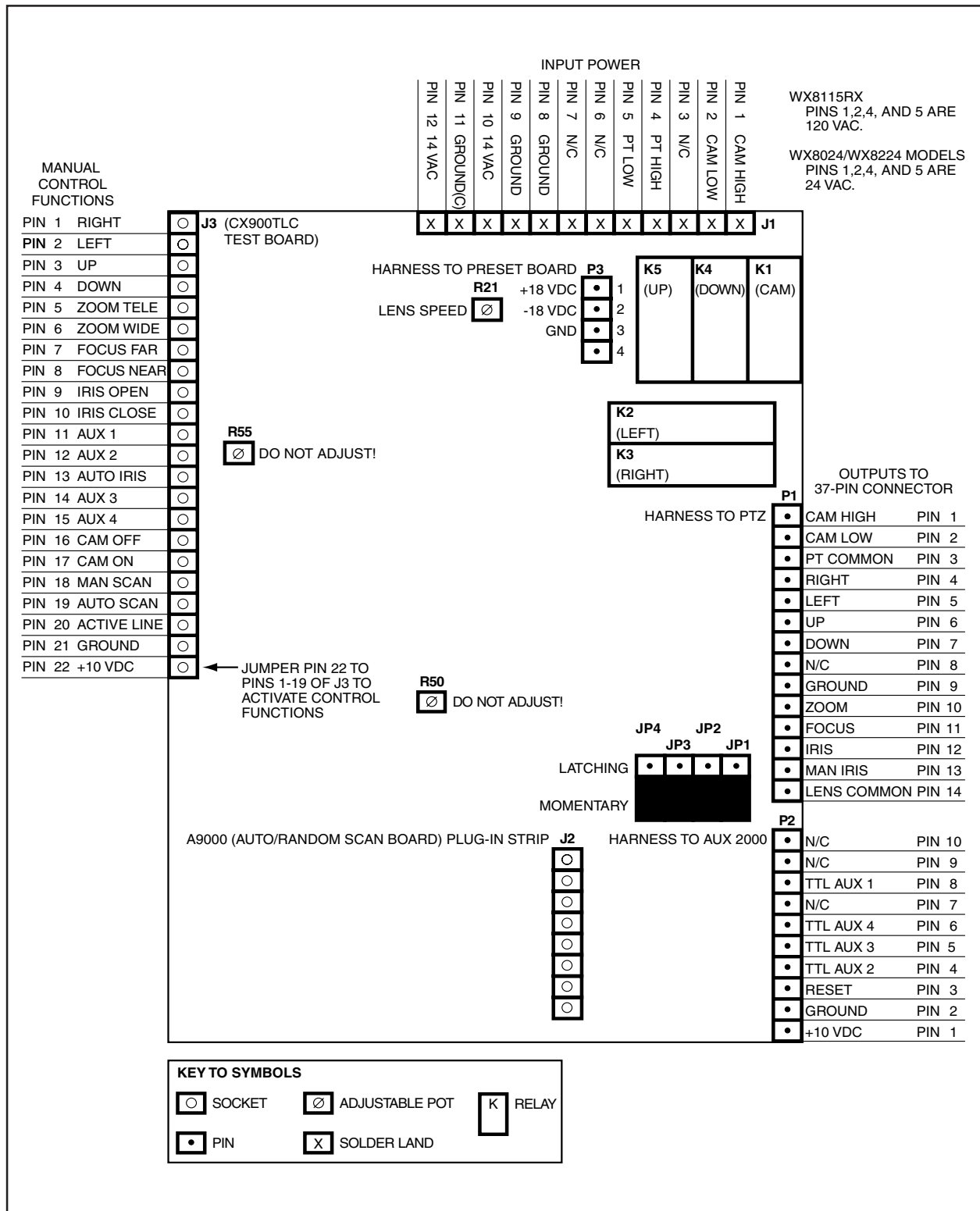

Figure 11. Receiver Pin Assignments

7.0 SPECIFICATIONS

MPT8000 CONTROLLER

ELECTRICAL

Input Voltage

MPT8000CZ: 120 VAC, 60 Hz

MPT8000CZ/220: 230 VAC, 60 Hz

Power Consumption: 2.5 vA

Control Method: 15 pulse train (pulse width modulated)

Pulse Amplitude: 35 mA current loop

Connectors: One 3-contact terminal block

Fuse Protection

MPT8000CZ,

MPT8000CZ/220: One 1/16 A, 3AG, slow blow fuse

Power Cord: 3-wire grounded #18 AWG

Cable Requirements: Twisted pair, unshielded

Operating Distance: Control cable distances are approximate according to wire used.

<u>Wire Gauge</u>	<u>Maximum Distance</u>
22 AWG	5 miles (8 km)
20 AWG	10 miles (16 km)

CONTROLS

Power ON/OFF: Rocker switch

Pan/Tilt: 8-position joystick

ZOOM: Paddle switch, TELE/WIDE

FOCUS: Paddle switch, NEAR/FAR

IRIS: Paddle switch, OPEN/CLOSE

PAN AUTO/MAN: Paddle switch (latching function in receiver)

CAMERA ON/OFF: Paddle switch (non-functional; receiver permanently in ON condition)

AUX 1, 2, 3, 4: Paddle switch (receiver provides +10 V, 20 mA output which can be used as latching or momentary functions)

Pilot Lamp: Long life neon

GENERAL

Construction and Finish: Black polyester powder coated steel

Operating Temperature: 32° to 120°F (0° to 49°C)

Dimensions: See Figure 12

Weights	Unit	Shipping
MPT8000CZ	7.5 lb (3.36 kg)	8 lb (3.62 kg)
MPT8000CZ/220	7.5 lb (3.36 kg)	8 lb (3.62 kg)

WX8000 RECEIVER/DRIVER

ELECTRICAL

Input Voltage
WX8024RX,
WX8024RXI: 120 VAC, 50/60 Hz

WX8024RX220,
WX8024RXI/220: 230 VAC, 50/60 Hz

WX8115RX: 120 VAC, 50/60 Hz

WX8220RX: 230 VAC, 50/60 Hz

WX8224RX,
WX8224RXI: 24 VAC, 50/60 Hz

Power Consumption
Receiver: 5 vA (120 VAC or 24 VAC)

Pan/Tilt Supply: 140 vA max. (120 VAC) 50 vA max. (24 VAC)

Lens Supply: 0-4 vA max.

Camera Supply: 15 vA (typical)

Control Method: 15-pulse train (pulse width modulated)

Pulse Amplitude: 35 mA current loop

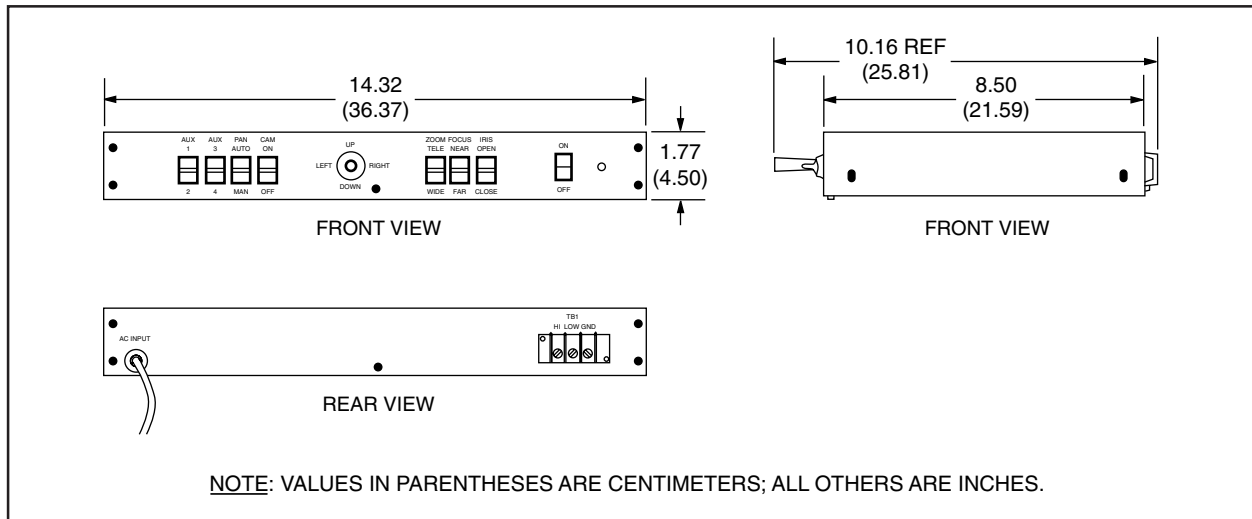

Figure 12. MPT8000 Series Controller Dimension Drawing

Connectors
Receiver Input: 3-contact terminal block
Receiver Output: 37-pin AMP CPC for control output (mate supplied)

Fuse Protection
WX8024RX, Fuse 1: Not used
WX8024RXI Fuse 2: 2/10 A, 3AG, slow blow fuse
Fuse 3: 1 A, 3AG, slow blow fuse

WX8024RX/220, Fuse 1: Not used
WX8024RXI/220 Fuse 2: 1/10 A, 3AG, slow blow fuse
Fuse 3: 1/2 A, 3AG, slow blow fuse

WX8115RX Fuse 1: 2/10 A, 3AG, slow blow fuse
Fuse 2: 2/10 A, 3AG, slow blow fuse
Fuse 3: 1 A, 3AG, slow blow fuse

WX8220RX Fuse 1: 1/10 A, 3AG, slow blow fuse
Fuse 2: 1/10 A, 3AG, slow blow fuse
Fuse 3: 1/2 A, 3AG, slow blow fuse

WX8224RX, Fuse 1: Not used
WX8224RXI Fuse 2: 1 A, 3AG, slow blow fuse
Fuse 3: 3 A, 3AG, slow blow fuse

Power Cord: 3-wire grounded, #18 AWG

Control Cable: Twisted pair, unshielded

GENERAL

Construction and Finish
Outdoor Models: Dark gray fiberglass
Indoor Models: Alodine aluminum

Latching
Outdoor Models: Two latches (accommodates padlocks - not supplied)

Operating
Temperature: -4° to 140°F (-20° to 60°C)

Environment: Indoor (RXI models)
Outdoor (All other models)

Weight	Unit	Shipping
	4 lb (1.81 kg)	6 lb (2.72 kg)

Dimensions
Outdoor Models: See Figure 13
Indoor Models: See Figure 14

(Design and product specifications subject to change without notice.)

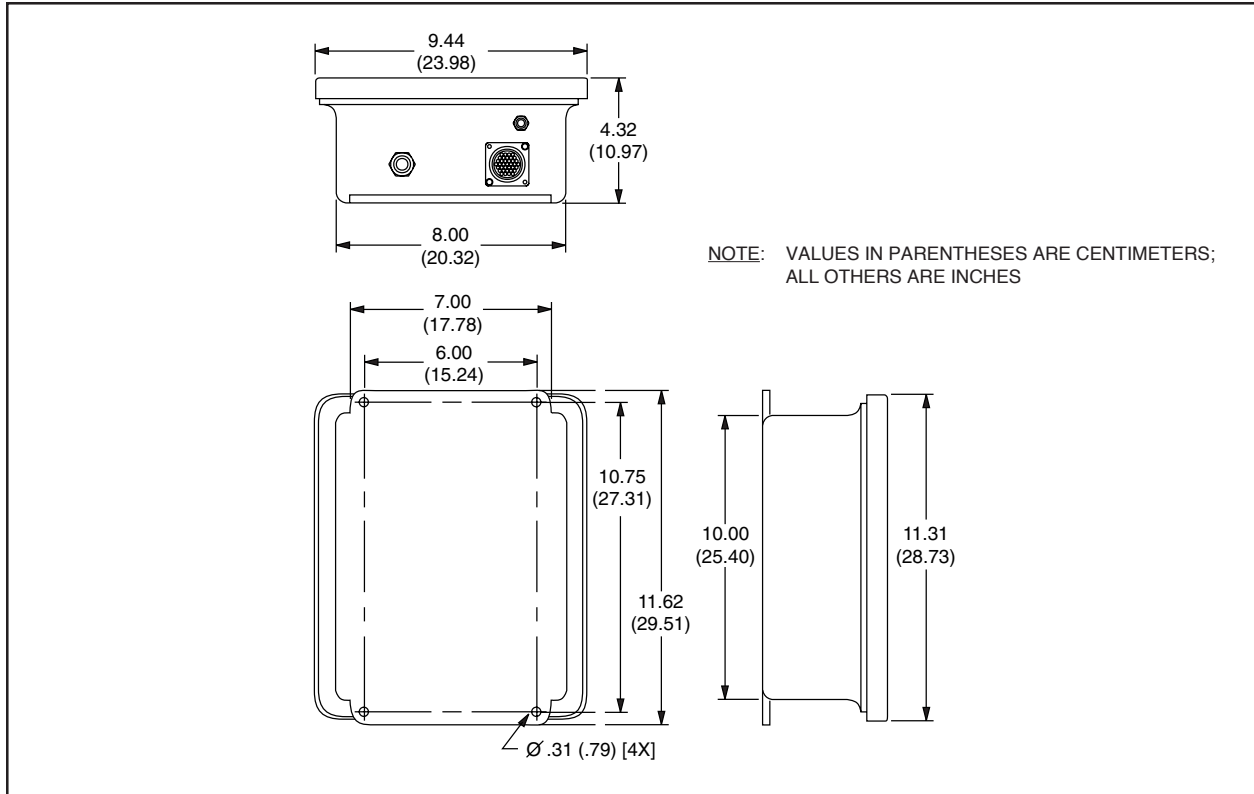

Figure 13. WX8000 Series Receiver Dimension Drawing (Outdoor Models)

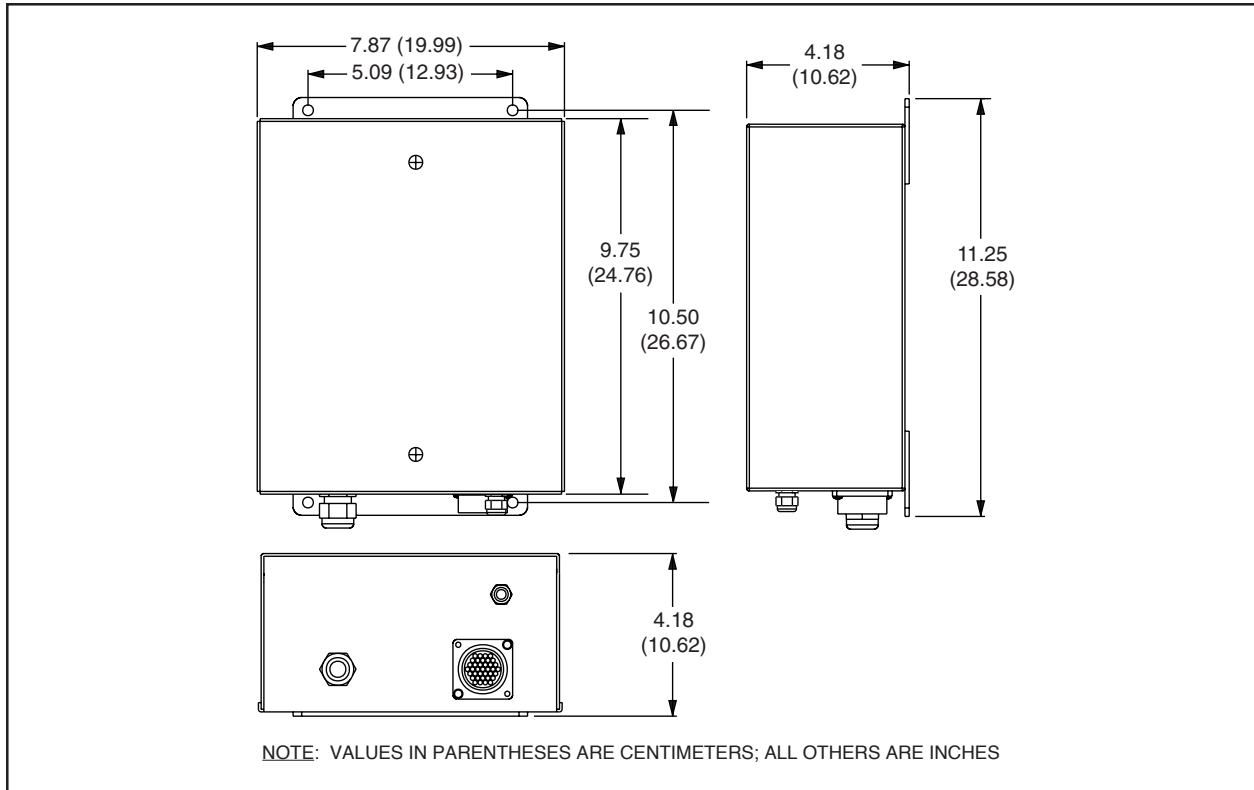

Figure 14. WX8000 Series Receiver Dimension Drawing (Indoor Models)

8.0 WARRANTY AND RETURN INFORMATION

WARRANTY

Pelco will repair or replace, without charge, any merchandise proved defective in material or workmanship for a period of one year after the date of shipment.

Exceptions to this warranty are as noted below:

- Five years on FT/FR8000 Series fiber optic products.
- Three years on Genex® Series products (multiplexers, server, and keyboard).
- Three years on Camclosure® and fixed camera models, except the CC3701H-2, CC3701H-2X, CC3751H-2, CC3651H-2X, MC3651H-2, and MC3651H-2X camera models, which have a five-year warranty.
- Two years on standard motorized or fixed focal length lenses.
- Two years on Legacy®, CM6700/CM6800/CM9700 Series matrix, and DF5/DF8 Series fixed dome products.
- Two years on Spectra®, Esprit®, ExSite™, and PS20 scanners, including when used in continuous motion applications.
- Two years on Esprit® and WW5700 Series window wiper (excluding wiper blades).
- Eighteen months on DX Series digital video recorders, NVR300 Series network video recorders, and Endura™ Series distributed network-based video products.
- One year (except video heads) on video cassette recorders (VCRs). Video heads will be covered for a period of six months.
- Six months on all pan and tilts, scanners or preset lenses used in continuous motion applications (that is, preset scan, tour and auto scan modes).

Pelco will warrant all replacement parts and repairs for 90 days from the date of Pelco shipment. All goods requiring warranty repair shall be sent freight prepaid to Pelco, Clovis, California. Repairs made necessary by reason of misuse, alteration, normal wear, or accident are not covered under this warranty.

Pelco assumes no risk and shall be subject to no liability for damages or loss resulting from the specific use or application made of the Products. Pelco's liability for any claim, whether based on breach of contract, negligence, infringement of any rights of any party or product liability, relating to the Products shall not exceed the price paid by the Dealer to Pelco for such Products. In no event will Pelco be liable for any special, incidental or consequential damages (including loss of use, loss of profit and claims of third parties) however caused, whether by the negligence of Pelco or otherwise.

The above warranty provides the Dealer with specific legal rights. The Dealer may also have additional rights, which are subject to variation from state to state.

If a warranty repair is required, the Dealer must contact Pelco at (800) 289-9100 or (559) 292-1981 to obtain a Repair Authorization number (RA), and provide the following information:

1. Model and serial number
2. Date of shipment, P.O. number, Sales Order number, or Pelco invoice number
3. Details of the defect or problem

If there is a dispute regarding the warranty of a product which does not fall under the warranty conditions stated above, please include a written explanation with the product when returned.

Method of return shipment shall be the same or equal to the method by which the item was received by Pelco.

RETURNS

In order to expedite parts returned to the factory for repair or credit, please call the factory at (800) 289-9100 or (559) 292-1981 to obtain an authorization number (CA number if returned for credit, and RA number if returned for repair).

All merchandise returned for credit may be subject to a 20% restocking and refurbishing charge. Goods returned for repair or credit should be clearly identified with the assigned CA or RA number and freight should be prepaid. Ship to the appropriate address below.

If you are located within the continental U.S., Alaska, Hawaii or Puerto Rico, send goods to:

Service Department
Pelco
3500 Pelco Way
Clovis, CA 93612-5699

If you are located outside the continental U.S., Alaska, Hawaii or Puerto Rico and are instructed to return goods to the USA, you may do one of the following:

If the goods are to be sent by a COURIER SERVICE, send the goods to:

Pelco
3500 Pelco Way
Clovis, CA 93612-5699 USA

If the goods are to be sent by a FREIGHT FORWARDER, send the goods to:

Pelco c/o Expeditors
473 Eccles Avenue
South San Francisco, CA 94080 USA
Phone: 650-737-1700
Fax: 650-737-0933

Pelco, the Pelco logo, Camclosure, Esprit, Genex, Legacy, and Spectra are registered trademarks of Pelco.
Endura and ExSite are trademarks of Pelco.

© Copyright 1999, Pelco. All rights reserved.

Free Manuals Download Website

<http://myh66.com>

<http://usermanuals.us>

<http://www.somanuals.com>

<http://www.4manuals.cc>

<http://www.manual-lib.com>

<http://www.404manual.com>

<http://www.luxmanual.com>

<http://aubethermostatmanual.com>

Golf course search by state

<http://golfingnear.com>

Email search by domain

<http://emailbydomain.com>

Auto manuals search

<http://auto.somanuals.com>

TV manuals search

<http://tv.somanuals.com>