

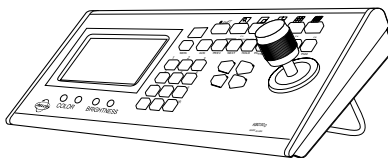

Installation/Operation

KBD300V Universal Keyboard

C519M-D (7/00)



Pelco • 3500 Pelco Way • Clovis, CA 93612-5699 USA • **Pelco Online** @ <http://www.pelco.com>
In North America and Canada: Tel (800) 289-9100 or FAX (800) 289-9150 • DataFAX (800) 289-9108
International Customers: Tel +1 (559) 292-1981 or FAX +1 (559) 348-1120 • DataFAX +1 (559) 292-0435
PelcoEurope BV • Dillenburg Center, Dillenburgstraat 5F • 5652 AM Eindhoven • The Netherlands
Tel +31(40) 251-9870 • FAX +31(40) 251-9835

CONTENTS

Section	Page
IMPORTANT SAFEGUARDS AND WARNINGS	2
Regulatory Notices	2
DESCRIPTION	3
Models	3
INSTALLATION - CM6700 MODE	4
INSTALLATION - DIRECT MODE	6
SWITCH SETTINGS	8
PROGRAMMING AND OPERATION	9
Scanning Functions	12
Programming Limit Stops	12
Zones	13
SPECIFICATIONS	14
INDEX	15
WARRANTY AND RETURN INFORMATION	16

IMPORTANT SAFEGUARDS AND WARNINGS

Prior to installation and use of this product, the following WARNINGS should be observed.

1. Installation and servicing should only be done by qualified service personnel and conform to all local codes.
2. This unit is designed for indoor use only, and it must not be installed where exposed to rain and moisture.
3. Only use replacement parts recommended by Pelco.
4. After replacement/repair of this unit's electrical components, conduct a resistance measurement between line and exposed parts to verify the exposed parts have not been connected to line circuitry.

Please thoroughly familiarize yourself with the information in this manual prior to installation and operation.

Regulatory Notices

NOTE: This equipment has been tested and found to comply with the limits of a Class A digital device, pursuant to part 15 of the FCC rules. These limits are designed to provide reasonable protection against harmful interference when the equipment is operated in a commercial environment. This equipment generates, uses, and can radiate radio frequency energy and, if not installed and used in accordance with the instruction manual, may cause harmful interference to radio communications. Operation of this equipment in a residential area is likely to cause harmful interference in which case the user will be required to correct the interference at his own expense.

DESCRIPTION

The KBD300V Universal Keyboard can be used in two operational modes. The KBD300V includes a 5-inch (12.7 cm) diagonal color monitor to make a complete, stand-alone viewing and control package.

CM6700 Mode: Program and operate the CM6700 Matrix Switcher/Controller Unit (SCU). Also control a Genex® multiplexer from a CM6700 SCU. Multiple keyboards can be used in this mode. (The KBD300V cannot be connected to the local keyboard port.)

Direct Mode: Control up to 16 receivers connected directly to the keyboard. Only one keyboard can be used in this mode. A separate system, such as an MS500 or VA6100 Switcher, is needed to route video to the monitor.

Models

KBD300V Keyboard with monitor, 120 VAC, 60 Hz, NTSC (CE, FCC)
 KBD300V-X Keyboard with monitor, 230 VAC, 50 Hz, PAL (CE)

Table A. KBD300V Operational Features

Function	CM6700 Mode	Direct Mode
Select cameras	Yes	Yes
Select monitors	Yes	No
Control lenses	Yes	Yes
Set and call presets/patterns	Yes	Yes
Control latching receiver auxiliaries	Yes	Yes
Control momentary receiver auxiliaries	Yes	Yes
Control multiplexer	Yes	No
Control CM6700 Matrix Switcher	Yes	No
Program CM6700 Matrix Switcher	Yes	No
Sequencing	Yes	No
Operate frame, auto, and random scans	Yes	Yes
Program and operate patterns*	Yes	Yes

* Firmware version 4.0 and higher

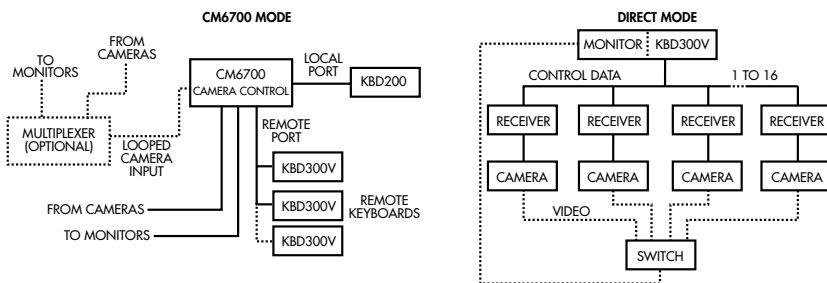

Figure 1. KBD300V Applications

INSTALLATION - CM6700 MODE

NOTE: There are two keyboard ports on the CM6700 SCU. The LOCAL KEYBOARD port cannot be used for the KBD300V.

To install KBD300V keyboards at the REMOTE KEYBOARD(S) port:

Refer to Figure 2. A KBD300V Interface is used to connect the KBD300V keyboard to the Remote Keyboard port on the back of the SCU or to another KBD300V Interface in a daisy-chain hookup. It can also connect to a wall block on either its input side or on its output side. You can have as many KBD300V keyboards as you have monitor outputs on your SCU.

- 1** Select a suitable location for the keyboard and interface. The interface must be within 6 feet (1.8 m) of a suitable electrical outlet and within 6 feet (1.8 m) of the keyboard. Attach the interface to the wall or other surface with the screws that are provided. Remove the cover if necessary, and replace when finished.
- 2** Connect a five-conductor (or larger) cable (user-supplied) from the SCU (or from a wall block or another interface) to the interface. Connect wires at the COM IN terminals. If additional keyboards follow the KBD300V, connect a cable from the interface output terminals to the next wall block or interface.
- 3** Connect a video cable from a monitor output on the SCU to the VIDEO IN jack on the interface.
- 4** Set the keyboard address switches for each keyboard according to the instructions on page 8.
- 5** Connect the keyboard data cable between the interface and the keyboard.
- 6** Connect the power supply to the interface and plug the transformer end into a suitable outlet.
- 7** Turn on the power switch on the back of the keyboard and apply power to the SCU (if not already powered).
- 8** To initialize the keyboard, wait five seconds after power up, enter the number for the monitor you are viewing (1-4), and press MON. The LED display shows the number entered.

NOTE: You must re-initialize whenever power is cycled.

- 9** Go to the *Programming and Operation* section and program and test for proper operation.

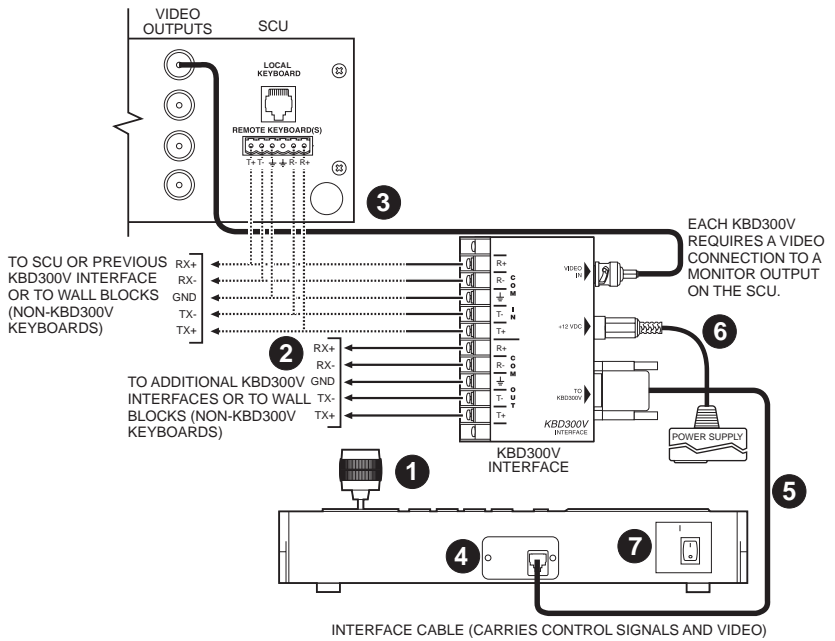

Figure 2. Wiring Diagram for Remote Keyboards

INSTALLATION - DIRECT MODE

Direct Mode is for a single-keyboard installation only. The keyboard is wired directly to a maximum of 16 receivers. Direct Mode installation/operation is not the same as CM6700 Mode installation/operation. A separate system, such as an MS500 or VA6100 switcher, is required for routing video to the monitor(s).

To connect the keyboard (refer to Figure 3).

- 1** Make sure all receivers are configured to communicate using Pelco P protocol at 4800 baud and that each receiver has a unique address. Refer to your receiver manual for switch settings.
- 2** Decide on a suitable location for the keyboard and interface module. The interface module must be within 6 feet (1.8 m) of the keyboard and of the nearest suitable electrical outlet.
- 3** Attach the KBD300V Interface module to the wall with the provided screws. Remove the cover, if necessary, and replace when finished.
- 4** Receiver wiring should be in place before installing the keyboard. You can control up to 16 receivers from the keyboard.

Communication to the keyboards is RS-485. Maximum cable distance for RS-485 communication over 24-gauge wire is 4,000 feet (1,219 m). Pelco recommends using shielded twisted pairs cable that meets or exceeds the basic requirements for EIA RS-485 applications.

- 5** Refer to Figure 3. Make receiver cable connections to the COM OUT terminals on the interface module.
 - Connect the TX+ terminal from COM OUT on the interface module to RX+ on the receiver.
 - Connect the TX- terminal from COM OUT on the interface module to RX- on the receiver.
 - Connect the ground terminal to the ground terminal on the receiver. (A ground connection may not be necessary if another ground path already exists).
- 6** Connect a video coaxial cable from the video out jack on a video switcher to the VIDEO IN jack on the interface module.
- 7** Set the keyboard DIP switches for Direct Mode according to the instructions on page 8.
- 8** Connect the keyboard data cable between the interface and the keyboard.
- 9** Connect the power supply to the interface and plug the transformer end into a suitable outlet. The LED display shows number 1, which is the default camera number.
- 10** Turn on the power switch on the back of the keyboard. The monitor comes on.
- 11** Go to the *Programming and Operation* section and program and test for proper operation.

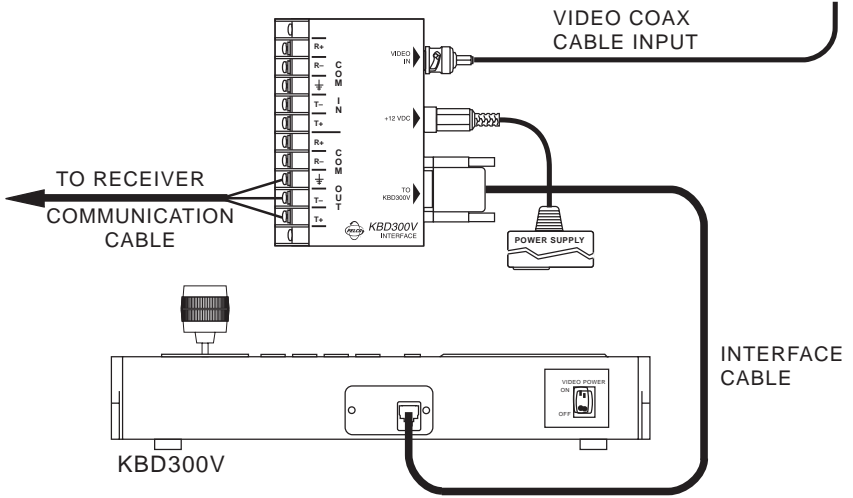

Figure 3. Keyboard Cabling Diagram

SWITCH SETTINGS

To set the switches on the keyboard (refer to Figure 4):

- 1 Remove the two screws and the DIP switch cover plate from the rear of the keyboard.
- 2 Set the switches:

• Address (Switches 1-4)

Position the switches according to Table B. Each keyboard in the system must have a different address, including the local keyboard. To make programming easier, address keyboards in ascending order.

NOTE: CM6700 accepts only eight addresses.

Table B. Keyboard Addresses

Keyboard	Address	Switch Settings			
		1	2	3	4
1	0	OFF	OFF	OFF	OFF
2	1	ON	OFF	OFF	OFF
3	2	OFF	ON	OFF	OFF
4	3	ON	ON	OFF	OFF
5	4	OFF	OFF	ON	OFF
6	5	ON	OFF	ON	OFF
7	6	OFF	ON	ON	OFF
8	7	ON	ON	ON	OFF
9	8	OFF	OFF	OFF	ON
10	9	ON	OFF	OFF	ON
11	10	OFF	ON	OFF	ON
12	11	ON	ON	OFF	ON
13	12	OFF	OFF	ON	ON
14	13	ON	OFF	ON	ON
15	14	OFF	ON	ON	ON
16	15	ON	ON	ON	ON

• Mode (Switches 5, 6, 8)

Table C. Keyboard Modes

	CM6700	Direct
Switch 5	OFF	ON
Switch 6*	ON or OFF*	ON or OFF*
Switch 8	OFF	OFF

* Switch 6 enables/disables turbo pan. (Can be switched while keyboard is on.)

• Not Used (Switch 7)

- 3 Replace the cover plate.

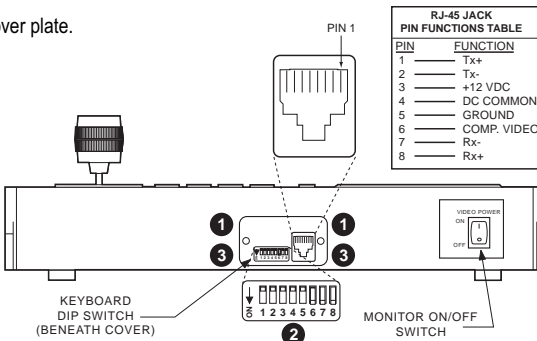

Figure 4. Keyboard Rear Panel

PROGRAMMING AND OPERATION

Table D. Keyboard Functions

Circled numbers refer to Figure 5.

Function	Procedure
Select Monitor*	LED display 1 shows monitor number in run mode. Enter monitor number (1-4) 15 and press MON 17 to select. NOTE: To view and control cameras on a monitor other than the one on the keyboard, enter the number of that monitor.
Select Camera	Enter camera number (1-16) 15 and press CAM 14 to select. NOTE: The CM6700 can be programmed to restrict some monitors from viewing certain cameras. To display a camera's view on your monitor, be sure that your keyboard shows the number of the monitor you are viewing and be sure that the CM6700 has not been programmed to restrict viewing of that camera.
Pan/Tilt/Zoom	Move the joystick 12 until the camera reaches the desired position. To increase the speed of movement, move the joystick further from center. Twist the joystick clockwise to zoom in, counterclockwise to zoom out.
Lens Control	Focus, iris - Press and hold the appropriate lens control key 11 until the desired effect is seen.
Presets	Enter preset number (1-66) 15 and press PRESET 9 to put camera in preset position. To program, position camera, enter desired preset number (1-66) 15 , and hold down PRESET 9 for two seconds. In CM6700 mode, a label appears on the monitor. Use F1 and F2 5 to edit the label, then select SET and press ACK 16 .
Patterns	Programming and operation varies with the receiver type. Spectra® domes (before version 3.0) can use one long (1 minute) or two short (0.5 minute) patterns. Spectra domes (version 3.0), Spectra II™ domes and Esprit™ Integrated Positioning Systems can use one long (1.5, 3 or 6 minutes) or two short (0.75, 1.5 or 3 minutes) patterns. (Select pattern lengths at the positioning system's menu.) To program Spectra and Esprit, select a camera (1-16) 15 , select a long pattern by holding down PATTERN 10 for two seconds, or select short pattern 1 or 2 by entering 1 or 2 15 and holding down PATTERN 10 for two seconds. The monitor will indicate the programming function is active. Move the camera position 12 as desired for the pattern and press ACK 16 to close the programming function. To run a long pattern, press PATTERN 10 . To run a short pattern, enter 1 or 2 15 and press PATTERN 10 . Move the joystick 12 or call a preset 9 to stop. Direct Mode is the same as above, except: Do not program a pattern with turbo pan on (switch 6).

*This function is not used in Direct Mode.

Continued on next page

Table D. Keyboard Functions (continued)

Function	Procedure
Sequence*	<p>Sequence steps through all 16 cameras. Camera number, camera title, sequence status, and time/date are shown on the monitor.</p> <p>Press PREV 4A to step back one camera. Hold for two seconds for a backward sequence. Monitor shows B. Press during sequence to speed up. Press during a forward sequence to reverse.</p> <p>Press NEXT 4B to step forward one camera. Hold for two seconds for a forward sequence. Monitor shows F. Press during sequence to speed up. Press during a backward sequence to go forward.</p> <p>Press HOLD 4C to hold a sequence. Monitor shows H. Press PREV or NEXT to resume.</p> <p>Manually select a camera or press CAM 14 to turn off a sequence. Monitor shows O.</p>
Macro Sequence*	<p>Enter 1 or 2 15 and press MACRO 8 to start a group camera sequence. Monitor shows M. Refer to the CM6700 manual for macro/sequence programming.</p>
Multiplexer Displays*	<p>Press SHIFT 2. Shift key LED 3 lights. The function keys F1 through F5 can now be used to display the images from multiple cameras on the monitor.</p> <p>F1: Zoom F2: PIP display F3: Quad display F4: 9-screen display F5: 16-screen display</p>
Auxiliaries/ Relays	<p>F1 – F3 5 control only the auxiliaries built into the CM6700 SCU. These outputs can be programmed for momentary, keyed, latched, or alarm operation. Refer to the CM6700 manual for programming instructions.</p> <p>F1: Activate/deactivate auxiliary 1 relay.* F2: Activate/deactivate switcher auxiliary 2 TTL output.* F3: Activate/deactivate switcher auxiliary 3 TTL output.* F4 and F5 control the auxiliaries in receivers.</p> <p>Enter the auxiliary number and press F4 to turn on. Hold, then release for momentary functions.</p> <p>Enter the auxiliary number and press F5 to turn off.</p> <p>In Direct Mode, F1- F3 5 have no function. LED 1 shows auxiliary number for two seconds after F4 or F5 5 is pressed.</p>
Acknowledge Alarm*	<p>Press ACK 16 to acknowledge an alarm. Refer to the CM6700 manual for further information on alarms.</p>
Program (CM6700)	<p>To program the CM6700 switcher, press PGM 7.</p> <p>Follow the programming procedure in the CM6700 manual. LED display shows P in program mode. Press ACK 16 to exit.</p>
LED	<p>LED 1 shows monitor number (in CM6700 Mode) or camera/receiver number (in Direct Mode) and P (in Program Mode).</p>
Firmware Version	<p>LED 1 flashes for a few seconds to show firmware version on power up (not functional on versions prior to 4.0).</p>
Clear	<p>Press CLEAR 13 to cancel a number that has been entered.</p>

*This function is not used in Direct Mode.

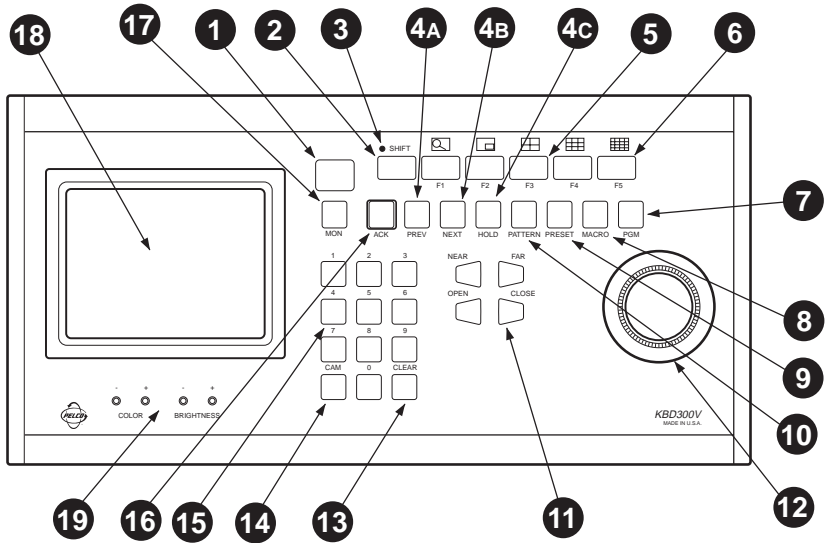

Figure 5. Keyboard Functions

Table E. KBD300V Button Functions

Reference Number	Description
1	LED display
2	Shift key
3	Shift key LED
4A-C	Sequence keys: Previous, Next, Hold
5	Function keys F1, F2, F3 control auxiliaries. With Shift on they control multiplexer display.
6	Functions keys F4, F5 control receiver auxiliaries. With Shift on they control multiplexer display.
7	Program key
8	Macro sequence key
9	Preset key
10	Pattern key
11	Focus and iris keys
12	Joystick
13	Clear key
14	Camera selection key
15	Keypad (numbers 1 through 0)
16	Acknowledge key
17	Monitor selection key
18	Monitor screen
19	Screen controls for color and brightness

Scanning Functions

Operation of the scanning functions depends on the kind of receiver or pan/tilt mechanism you have and the operating mode of your keyboard (CM6700 or Direct Mode).

There are four types of scanning functions: auto (moves camera back and forth between stops), random (moves camera in a random pattern), frame (moves camera back and forth in 10 degree steps), and preset (sequences camera through all programmed presets, pausing between each).

Operate scans according to Table F.

Table F. Operating Scan Functions with Various Receivers

Receiver Model	Controlling Protocol	Function				
		Auto Scan	Random Scan	Frame Scan	Preset	Stop Scan
All Pelco	15-bit (standard) Coaxitron®	97 Preset (1) (3)	97 Preset (1)	N/A	(2)	96 Preset
IRD2024 ERD2200	Extended Coaxitron	98 Preset or 99 Preset (3)	97 Preset	N/A	N/A	96 Preset
All Spectra All Esprit	Ext. Coax., Serial Pelco P or D	99 Preset	97 Preset	98 Preset	N/A	96 Preset or PTZ
LRD41C (before ver. 2.98)	Ext. Coax., Serial Pelco P or D	99 Preset (1) (3)	99 Preset (1)	N/A	N/A	96 Preset
LRD41C (ver 2.98 and later)	Ext. Coax., Serial Pelco P or D	99 Preset (3)	97 Preset	N/A	N/A	96 Preset
ERD97P21-U	Serial Pelco P	N/A	97 Preset	98 Preset	N/A	96 Preset

(1) First entry starts random scan, next entry changes to auto scan, etc.

(2) Enter dwell time (5-64 sec.) and press IRIS CLOSE.

(3) Changes to random scan after 30 minutes.

Programming Limit Stops

Spectra and Esprit can be programmed for scan and manual limit stops.

Program left limit before programming right limit. Locate camera at desired limit. Enter the set code from Table G. Hold the PRESET key for two seconds. In CM6700 Mode, a label appears on the monitor. Use F1 and F2 to edit the label, then select SET and press ACK.

To cancel all limit stops, enter 95. Hold the preset key for two seconds. Use the up down tilt keys to move the pointer to Other. Press IRIS OPEN. Move the pointer to Limit Stops. Press IRIS OPEN. Use the tilt keys to change limit stops to off. Press IRIS OPEN. Move the pointer to EXIT. Press IRIS OPEN. Move pointer to exit. Press IRIS OPEN.

Table G. Limit Set Codes

Direction	Scan Limit	Manual Limit
Left Limit	92	90
Right Limit	93	91

Zones

The Zone function is available on Esprit and Spectra positioning systems. This function puts a label on the screen to identify the viewing area. Zones can also be blanked* to prevent viewing while the camera is positioned in the zone.

Up to eight pan (horizontal) zones can be defined (zones are not affected by tilt or zoom). Higher numbered zones take precedence so that if zones overlap, the one with the higher number is in effect. Zone programming is outlined in Table H.

Table H. Zone Programming Procedure

Step	Procedure
1. Set left zone limit.	a. Use the joystick to position the camera at the start (left limit) of the zone.
2. Access zone programming.	a. Press 8, followed by the zone number N (N = 1 through 8), and then F4 to display the zone menu.
3. Define a label. HINT: To ease future title editing, start each title with Z(N), where N = zone number.	<p>a. Use F1 and F2 to find the characters for each position in the label (26 upper case letters, 26 lower case letters and 10 numbers).</p> <p>b. Pan left/right to move between character positions. Continue selecting characters until the title is completed (up to 20 characters).</p> <p>c. Move down to the SET field and press ACK.</p>
4. Set right zone limit.	<p>a. Position camera at the right limit of the zone.</p> <p>b. Press 8, followed by the zone number, and then F5.</p> <p>c. To view zone titles go to step 6.</p>
5. Clear zones.	<p>a. Press 8, followed by the zone number, and then F4.</p> <p>b. Move down to the SET field and Press ACK.</p> <p><i>NOTE: DO NOT pan right.</i></p> <p>c. Press 8, followed by the zone number, and then F5.</p>
6. Tun on zones.	a. Press 8, 8, Preset.
7. Blank zones.*	<p>a. Press 9, 5 and hold Preset for about 2 seconds to display the Edit Preset 95 menu.</p> <p>b. Move down to the SET field and press ACK to display the Camera menu.</p> <p>c. Move down to the <Alarms, Zone Blank> field and press Iris Open to display the Alarms, Zone Blank menu.</p> <p>d. Move down to the <Zone Blank> field and press Iris Open to display the Zone Blank menu.</p> <p>e. Move down to the zone number you wish to blank and press Iris Open to move the cursor arrow to the zone blanking status value.</p> <p>f. Pan up to turn blanking on, pan down to turn blanking off.</p> <p>g. Press Iris Open to accept new status; press Iris Close to cancel.</p> <p>h. Repeat steps 7e through 7g for each zone you wish to change, then go to step 7i.</p> <p>i. Move down to Exit and press Iris Open repeatedly to move up through the menus and return to the normal display.</p>

* Not available in Esprit systems.

SPECIFICATIONS

GENERAL

Keyboard Keypad:	Mechanical
Display:	Red LED, 7-segment, 2 cells
Joystick:	3-axis, vector-solving, with twisting, return-to-center head
Shift Mode Indicator:	Green LED
Storage Temperature:	-4° to 140°F (-20° to 60°C)
Ambient Operating Temperature:	14° to 140°F (-10° to 60°C)
Humidity:	10–90% non-condensing
Dimensions:	14.63 (W) x 7.125 (D) x 2.25 (H) inches (37.2 x 18.1 x 5.72 cm)
Weight:	4.3 lb (1.95 kg)

LCD MONITOR

Display Size:	5-inch diagonal (12.7 cm)
Display Method:	TFT Active Matrix System
Input Signal:	NTSC/PAL
Input Signal Level:	1.0 Vp-p, 75 ohms
Backlight:	CCFT Backlight
Power Supply:	+12 VDC, 500 mA
Screen Controls:	Brightness and color

ELECTRICAL

Input Voltage:	+12 VDC @ 1 Amp
Power Consumption:	8 watt
Connector Type:	RJ-45, 8-pin, modular (female)

Keyboard Communication, 6700 Mode

Interface:	RS-485
Protocol:	Pelco ASCII
Baud:	9600
Communication Parameters:	8 data bits, odd parity, 1 stop bit

Keyboard Communication, Direct Mode

Interface:	RS-422
Protocol:	Pelco P
Baud:	4800
Communication Parameters:	8 data bits, no parity, 1 stop bit

MECHANICAL

Tilt Stand:	Adds additional 20° viewing angle
-------------	-----------------------------------

(Design and product specifications subject to change without notice.)

INDEX

A

Acknowledge 10
Auxiliaries 10

C

Clear 10

D

DIP switch 8

F

Firmware version 10

G

Genex multiplexer 3

I

Installation
 CM6700 Mode 4
 Direct Mode 6

K

Keyboard addresses 8

L

LED 10
Lens Control 9
Limit stops 12

M

Macro sequence 10
Multiplexer displays 10

O

Operation 9
Operational features 3

P

Pan/Tilt 9
Patterns 9
Presets 9
Program 10
Programming 9

R

Regulatory notices 2
Relays 10
Returns 16

S

Safeguards 2
Scanning 12
Select camera 9
Select monitor 9
Sequence 10
Specifications 14
Switch settings 8

W

Warranty 16

Z

Zoom 9

WARRANTY AND RETURN INFORMATION

WARRANTY

Pelco will repair or replace, without charge, any merchandise proved defective in material or workmanship for a period of one year after the date of shipment. Exceptions to this warranty are as noted below:

- Three years on Genex® Series (multiplexers, server, and keyboard).
- Two years on cameras and all standard motorized or fixed focal length lenses.
- Two years on Legacy®, Camclosure™ Camera Systems, CM6700/CM8500/CM9500/CM9750/CM9760 Matrix, PelcoVision®, DF5 Series and DF8 Fixed Dome products.
- Two years on Spectra® and Esprit™, including when used in continuous motion applications.
- Two years on WW5700 series window wiper (excluding wiper blades).
- Six months on all pan and tilts, scanners or preset lenses used in continuous motion applications (that is, preset scan, tour and auto scan modes).

Pelco will warrant all replacement parts and repairs for 90 days from the date of Pelco shipment. All goods requiring warranty repair shall be sent freight prepaid to Pelco, Clovis, California. Repairs made necessary by reason of misuse, alteration, normal wear or accident are not covered under this warranty.

Pelco assumes no risk and shall be subject to no liability for damages or loss resulting from the specific use or application made of the Products. Pelco's liability for any claim, whether based on breach of contract, negligence, infringement of any rights of any party or product liability relating to the Products shall not exceed the price paid by the Dealer to Pelco for such Products. In no event will Pelco be liable for any special, incidental or consequential damages (including loss of use, loss of profit and claims of third parties) however caused, whether by the negligence of Pelco or otherwise.

The above warranty provides the Dealer with specific legal rights. The Dealer may also have additional rights, which are subject to variation from state to state.

If a warranty repair is required, the Dealer must contact Pelco at (800) 289-9100 or (559) 292-1981 to obtain a Repair Authorization number (RA), and provide the following information:

1. Model and serial number
2. Date of shipment, P.O. number, Sales Order number, or Pelco invoice number
3. Details of the defect or problem

If there is a dispute regarding the warranty of a product which does not fall under the warranty conditions stated above, please include a written explanation with the product when returned.

Method of return shipment shall be the same or equal to the method by which the item was received by Pelco.

RETURNS

In order to expedite parts returned to the factory for repair or credit, please call the factory at (800) 289-9100 or (559) 292-1981 to obtain an authorization number (CA number if returned for credit, and RA number if returned for repair). Goods returned for repair or credit should be clearly identified with the assigned CA/RA number and freight should be prepaid. All merchandise returned for credit may be subject to a 20% restocking and refurbishing charge.

Ship freight prepaid to: Pelco
3500 Pelco Way
Clovis, CA 93612-5699

REVISION HISTORY

Manual #	Date	Comments
C519M	12/97	Original version.
C519M-A	1/98	Added installation and operation instructions for Direct Mode. Added operation instructions for CM6700 Mode.
C519M-B	9/98	Revised manual to show new DIP switch and switch settings.
C519M-C	3/99	Revised manual to show changes to keyboard's screen, screen display controls, and how the keyboard is wired for use. Revised, added, and deleted figures throughout the manual. Changed manual to new format.
	6/99	Revised the sequence key definitions. Added paragraphs on how to turn off Spectra scan and manual limit stops. Added material on programming Spectra features to the Direct Mode Operation section.
	9/99	Corrected step 3 and Figure 9 of Direct Mode Keyboard Installation section. Added patent number.
C519M-D	7/00	Revised format.

© Pelco, the Pelco logo, Spectra, Genex, Legacy, Coaxitron, and PelcoVision are registered trademarks of Pelco.

™ Esprit, Spectra II, and Camclosure are trademarks of Pelco.

© Copyright 2000, Pelco. All rights reserved.
U.S. Patent No. 411, 530.

Free Manuals Download Website

<http://myh66.com>

<http://usermanuals.us>

<http://www.somanuals.com>

<http://www.4manuals.cc>

<http://www.manual-lib.com>

<http://www.404manual.com>

<http://www.luxmanual.com>

<http://aubethermostatmanual.com>

Golf course search by state

<http://golfingnear.com>

Email search by domain

<http://emailbydomain.com>

Auto manuals search

<http://auto.somanuals.com>

TV manuals search

<http://tv.somanuals.com>