

SEARS

PARTS MANUAL

MODEL NO.
919.152920

Important:
Before using this
equipment, read all
Safety Precautions
and both manuals.
Retain for future use.



CRAFTSMAN PERMANENTLY LUBRICATED AIR COMPRESSOR

SPECIFICATION CHART

Model No.	919.152920
Horsepower	4
Displacement CFM	11.9
Bore	2 3/8"
Stroke	1.35"
Voltage-Single Phase	120/240
Minimum Branch Circuit Requirement	*15 amps
**Fuse Type	Time Delay
Air Tank Capacity - GAL.	-25 gal. ASME
Approximate Cut-in Pressure	100
Approximate Cut-out Pressure	125
SCFM @ 40 psig	9.0
SCFM @ 90 psig	7.0

These compressors have a dual voltage motor, 120 and 240 volt. They are wired for 120 volt but can be converted to 240 volt operation. Conversion should be performed by Authorized Warranty Service Personnel.

CAUTION

When converting to 240 volt operation, the attached three-prong 120 volt plug must be replaced with the three-prong 240 volt plug, which is included in KK-5056. The KK-5056 Kit may be ordered from Sears.

*These compressors can be operated on a 15 amp circuit if:

1. Voltage supply to circuit is normal.
2. Circuit is not used to supply any other electrical needs (lights, appliances, etc.)
3. Extension cords comply with specifications in owners manual.
4. Circuit is equipped with 15 amp circuit breaker or 15 amp time delay fuse.

different motor safety valve reducer (for dia)

If any of the above conditions cannot be met, or if operation of the compressor repeatedly causes interruption of the power, it may be necessary to operate it from a 20 amp circuit. It is not necessary to change the cord set.

**A circuit breaker is preferred. Use only a fuse or circuit breaker that is the same rating as the branch circuit the air compressor is operated on. If the air compressor is connected to a circuit protected by fuses, use dual element time delay fuses.

Sears, Roebuck and Co., Chicago, IL 60684 U.S.A.

M-152920 1/20/94

AIR COMPRESSOR DIAGRAM

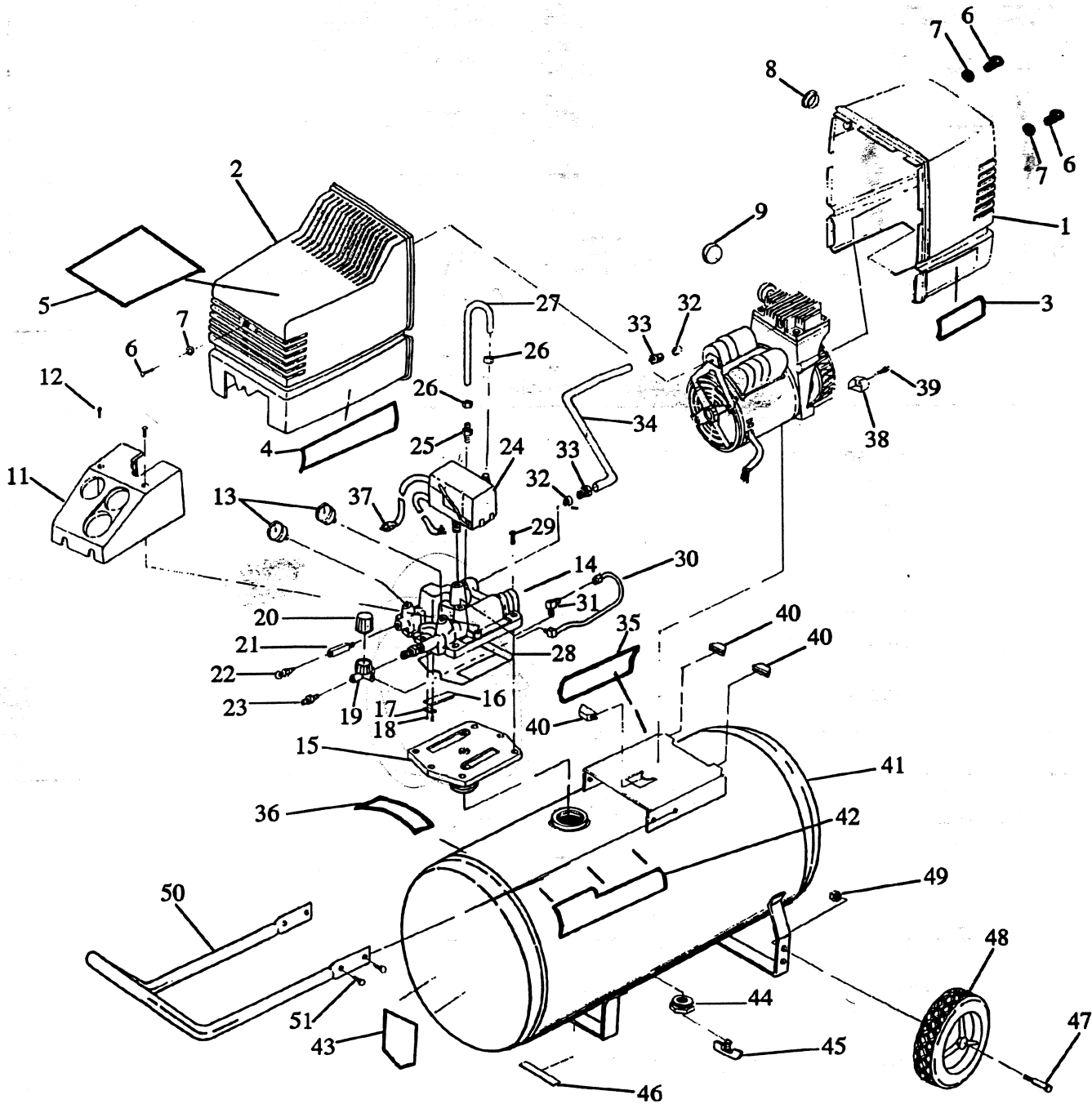

PARTS LIST

KEY NO.	PARTNUMBER	DESCRIPTION
1	CAC-1317	Shroud, Front
2	CAC-1318 AC-0029	Shroud, Rear
3	LA-2538	Label, Performance
4	LA-2537	Label, Billboard
5	CL-292	Label, Model Number
6	SSF-553	Screw #10-24x9/16 Pan HD (3 used)
7	SSG-3102	O-ring (3 used)
x 8	CAC-1373	Filter Retainer
x 9	CAC-1372	Filter Foam
---	---	---
11	CAC-1321	Console, Shroud
12	SSF-558	Screw, (2 used-Torque 30-45 in./lbs/)
13	GA-362	Pressure Guage (2 used)
14	CAC-1348	Manifold, top
15	CAC-1352	Manifold, bottom
16	265-196-1	Valve, Flapper
17	CAC-1391	Restrictor, Check Valve
18	SSF-9821	Screw, THD Forming 5-40x1 (2 used- Torque 13-17 in./lbs.)
19	CAC-4296-1	Regulator
20	CAC-1370	Knob, Acorn Regulator
21	CAC-1377	Safety Valve Adaptor
22	TIA-6126	Safety Valve
23	H-2101	Adaptor (Torque 7-10 ft./lbs.)
24	CAC-1383	Pressure Switch
25	SS-8553	Connector Body
26	SSP-7811	Nut/Sleeve Assy. (2 used)
27	CAC-1388	Pressure Relief Tube
28	SSG-3100	O-ring, Manifold
29	SSF-990	Screw 1/4-20 (6 used-Torque 8-11 ft./lbs.)
30	CAC-4125	Tube Assy.
31	SSP-6422	Elbow 90°
32	CAC-1369	Silicone Sleeve (2 used)
33	SSF-550	Compression Nut (2 used-Torque 120-140 in./lbs.)
34	CAC-1368	Outlet Tube
35	LA-2643	Label, Warning
36	LA-2621	Label, Warning - Manifold
37	SUDL-413-2	Cord Assembly
38	ACG-18	Cup, Saddle Mount (2 used)
39	91895680	Screw, 1/4-20 x .75 (2 used-Torque 9-12 ft./lbs.)
40	ACG-19	Isolator (3 used)
41	TA-4272	Tank -25 Gal.
42	LA-1811-1	Label, Sears Craftman
43	LA-1978-1	Label, Drain Tank
44	SSP-470	Hex Reducer Bushing
45	SS-2707	Drain Valve
46	SUDL-6-1	Strip, Rubber Foot
47	CAC-60	Shoulder Bolt (2 used)
48	CAC-4313	Wheel, 10" (2 used)
49	SSF-8080-ZN	Nut, Hex 3/8" (2 used)
50	CAC-1374	Handle
51	SSF-981	Screw (4 used)

COMPRESSOR PUMP DIAGRAM

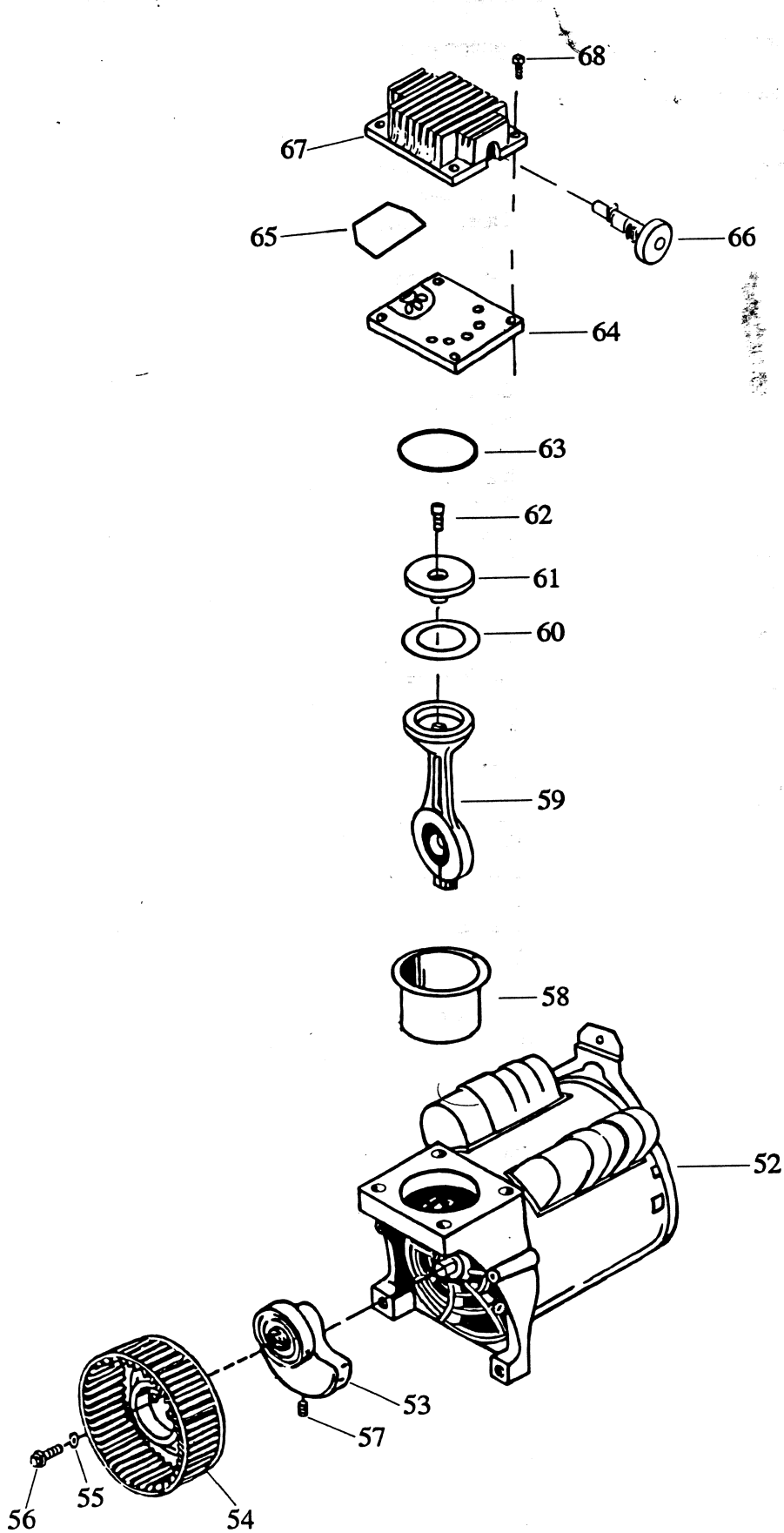

PARTS LIST

<u>KEY NO.</u>	<u>PARTNUMBER</u>	<u>DESCRIPTION</u>
52	MO-9041-1	Motor
53	CAC-4086	Eccentric Bearing Assy.
* 54	CAC-1148-1	Fan
* 55	SS-6505-CD	Washer
* 56	SSF-3155	Screw 1/4 - 28 (Torque 75-90 in./lbs.)
57	SSF-3153	Screw (Eccentric, torque 120-140 In. Lbs.)
.58	CAC-249-3	Sleeve, Cylinder
.59	ACG-401	Connecting Rod
.60	CAC-248-2	Compression Ring
.61	ACG-29	Connecting Rod Cap
.62	SSF-3158-1	Screw, #10-24
63	SSG-8156	O-ring
64	ACG-402	Valve Plate Assy.
65	ACG-45	O-ring, Head
66	CAC-1371	Muffler
67	ACG-31	Head
68	SSF-990	Screw 1/4" - 20 x 1 1/4" (4 used, torque 7-10 Ft. Lbs.)

NOT ILLUSTRATED

M-152920	Parts Manual
MG-OILFREE	General Manual
H-7038	1/4" x 15 Hose
SSH-20	Air Chuck

- Key No's 58, 59, 60, 61 and 62 can be purchased as KK-4835 Connecting Rod Kit.
- x Key No's 8 and 9 can be purchased as KK-5041 Muffler/Foam Kit.
- * Key No's 54, 55, and 56 can be purchased only as KK-5018.

Start cap. smaller than 152921

Free Manuals Download Website

<http://myh66.com>

<http://usermanuals.us>

<http://www.somanuals.com>

<http://www.4manuals.cc>

<http://www.manual-lib.com>

<http://www.404manual.com>

<http://www.luxmanual.com>

<http://aubethermostatmanual.com>

Golf course search by state

<http://golfingnear.com>

Email search by domain

<http://emailbydomain.com>

Auto manuals search

<http://auto.somanuals.com>

TV manuals search

<http://tv.somanuals.com>