

Save This Manual
For Future Reference

SEARS

**owner's
manual**

MODEL NO.

113.197411

**10-INCH ELECTRONIC
RADIAL SAW WITH
44-INCH CABINET
AND 2 DOORS**

OR

113.197511

**10-INCH ELECTRONIC
RADIAL SAW
WITH 44-INCH CABINET
AND 2 DOORS AND
CASTERS**

OR

113.197611

**10-INCH ELECTRONIC
RADIAL SAW WITH
44-INCH CABINET
AND 6 DRAWERS**

Serial

Number _____

Model and serial numbers
may be found on the left
hand side of the base.

You should record both
model and serial number in
a safe place for future use.

**FOR YOUR
SAFETY:**

**READ ALL
INSTRUCTIONS
CAREFULLY**

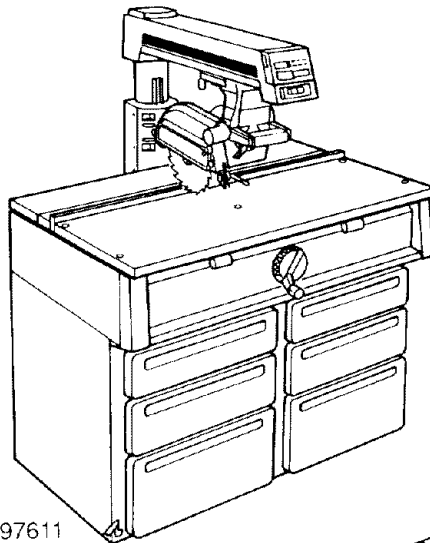

113.197611

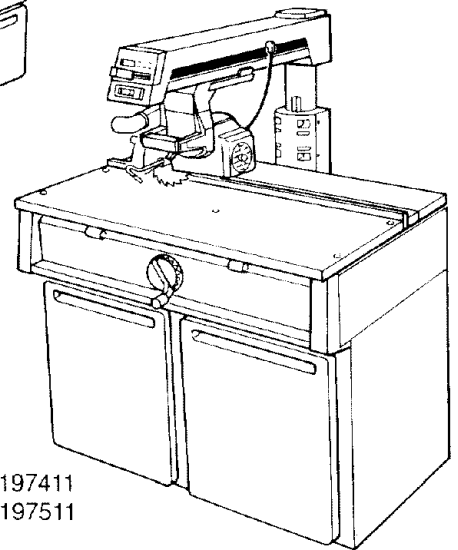

113.197411

113.197511

SEARS / CRAFTSMAN

10-INCH RADIAL SAW

- assembly
- operating
- repair parts

Sold by SEARS, ROEBUCK AND CO., Chicago, IL 60684 U.S.A.

Part No. SP5539

Printed in U.S.A.

Table of Contents

Section Title	Page
Safety	3
Assembly	10
Controls	34
Alignment and Adjustment	37
Digital Display	48
Electrical Connections	54
Crosscutting	57
Ripping	61
Cutting Aides	69
Accessories	72
Maintenance	75
Troubleshooting	79
Repair Parts	84
Index	103

FULL ONE YEAR WARRANTY ON CRAFTSMAN RADIAL ARM SAW

If within one year from the date of purchase, this Craftsman Radial Saw fails due to a defect in material or workmanship, Sears will repair it, free of charge.

WARRANTY SERVICE IS AVAILABLE BY SIMPLY CONTACTING THE NEAREST SEARS SERVICE CENTER/DEPARTMENT THROUGHOUT THE UNITED STATES.

This warranty applies only while this product is used in the United States.

This warranty gives you specific legal rights and you may also have other rights which vary from state to state.

**SEARS, ROEBUCK AND CO. DEPT. 698/731A SEARS TOWER,
CHICAGO, IL 60684**

This manual has safety information and instructions to help users eliminate or reduce the risk of accidents and injuries, including:

1. Severe cuts, and loss of fingers or other body parts due to contact with the blade
2. Eye impact injuries, and blindness, from being hit by a thrown workpiece, workpiece chips or pieces of blade
3. Bodily impact injuries, broken bones, and internal organ damage from being hit by a thrown workpiece
4. Shock or electrocution
5. Burns.

Safety Symbol and Signal Words

An exclamation mark inside a triangle is the safety alert symbol.

It is used to draw attention to safety information in the manual and on the saw. It is followed by a signal word, DANGER, WARNING, or CAUTION, which tells the level of risk:

⚠ DANGER: means if the safety information is not followed someone **will** be seriously injured or killed.

⚠ WARNING: means if the safety information is not followed someone **could** be seriously injured or killed.

⚠ CAUTION: means if the safety information is not followed someone **might** be injured.

Read and follow all safety information and instructions.

Major Hazards

Three major hazards are associated with using the radial arm saw for ripping. They are outfeed zone hazard, kickback, and wrong way feed.

This section only briefly explains these hazards. Read the ripping and crosscutting safety sections for more detailed explanations of these and other hazards.

Outfeed Zone Hazard

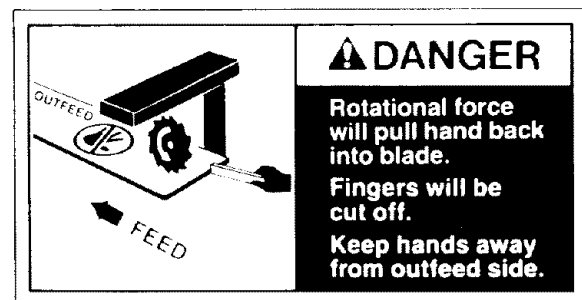

If you reach around the blade to the outfeed side when ripping, and try to hold down or pull the workpiece through to complete a cut, the rotational force of the blade will pull your hand back into the blade.

Fingers will be cut off.

Read and follow the information and instructions under ripping safety.

Safety

Kickback Hazard

Kickback is the uncontrolled propelling of the workpiece back toward the user during ripping.

The cause of kickback is the binding or pinching of the blade in the workpiece. Several conditions can cause the blade to bind or pinch.

When a workpiece kicks back, it could hit hard enough to cause internal organ injury, broken bones, or death.

Read and follow the information and instructions under ripping safety .



Wrong Way Feed Hazard

Wrong way feed is ripping by feeding the workpiece into the outfeed side of the blade.

The rotational force of the blade can grab and pull the workpiece.

Before you can let go or pull back, the force could pull your hand along with the workpiece into the blade. Fingers or hand could be cut off.

The propelled workpiece could hit a bystander, causing severe impact injury or death.

Read and follow the information and instructions under ripping safety.



Safety Instructions

Read and follow all safety instructions.

Personal Safety Instructions

1. Wear safety goggles labeled "ANSI Z87.1" on the package. It means the goggles meet impact standards set by the American National Standards Institute. Regular eyeglasses are not safety goggles.
2. Wear close fitting clothes, short sleeved shirts, and non-slip shoes. Tie up long hair. Do not wear gloves, ties, jewelry, loose clothing, or long sleeves. These can get caught in the spinning blade and pull body parts into the blade.
3. Wear dust mask to keep from inhaling fine particles.
4. Wear ear protectors, plugs or muffs if you use saw daily.
5. Keep good footing and balance; do not over-reach.

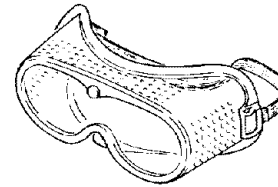

Safety Goggles

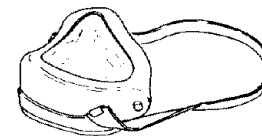

Dust Mask

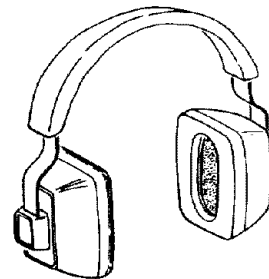

Ear Protectors

Work Area Safety Instructions

1. Keep children, pets, and visitors out of work area; they could be hit by a thrown workpiece, workpiece chips or pieces of blade.
2. Turn saw off, remove yellow key, and unplug before leaving work area. Do not leave until blade has stopped spinning.
3. Make work area child-proof: remove yellow key to prevent accidental start-up; store key out of sight and reach; lock work area.
4. Keep floors clean and free of sawdust, wax and other slippery materials.
5. Keep work area well lighted and uncluttered.
6. Use saw only in dry area. Do not use in wet or damp areas.

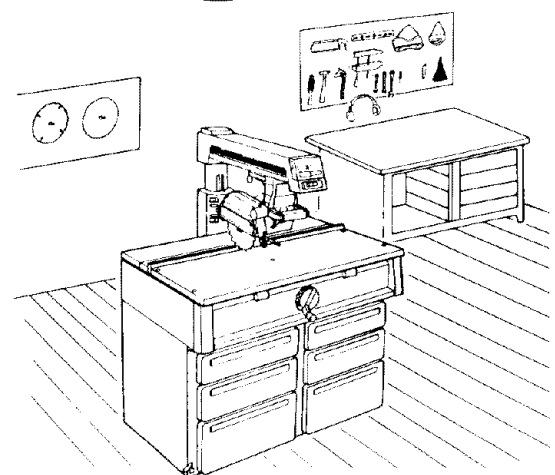

Safety

Saw Safety Instructions

1. Use guard, pawls and spreader according to instructions. Keep them in working order.
2. Routinely check saw for broken or damaged parts. Repair or replace damaged parts before using saw. Check new or repaired parts for alignment, binding, and correct installation.
3. Unplug saw before doing maintenance, making adjustments, correcting alignment, or changing blades.
4. Do not force saw. Use saw, blades and accessories only as intended.
5. Have yellow key out and saw switched off before plugging in power cord.

Workpiece Safety Instructions

1. Cut only wood, woodlike or plastic materials. Do not cut metal.
2. Cut only one workpiece at a time. Stacking or placing workpieces edge to edge can cause user to lose control of workpiece.

6. Before turning on saw, clear table of all objects except workpiece to be cut and necessary fixtures, clamps, or featherboards.
7. If blade jams, turn saw off immediately, remove yellow key, then free blade. Do not try to free blade with saw on.
8. Turn saw off if it vibrates too much or makes an odd sound. Correct any problem before restarting saw.
9. Do not layout, assemble, or setup work with saw on, or while blade is spinning.
10. Keep saw table clean.
11. Store items away from saw. Do not climb on saw or stand on saw table to reach items because saw can tip over.

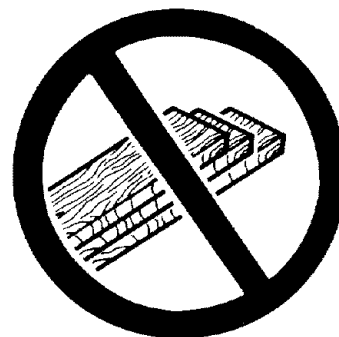
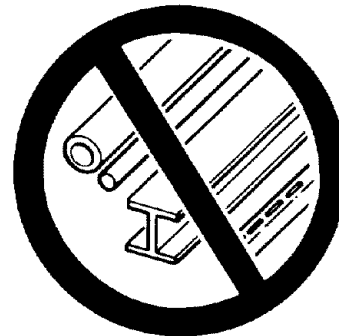
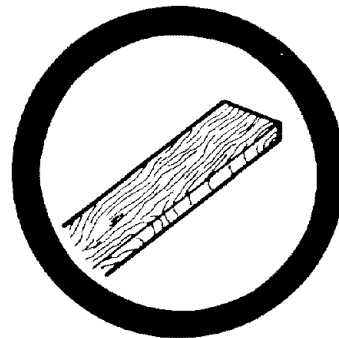

3. Rip only workpieces longer than the diameter of the blade. Do not rip workpieces that are shorter than the diameter of the blade being used.

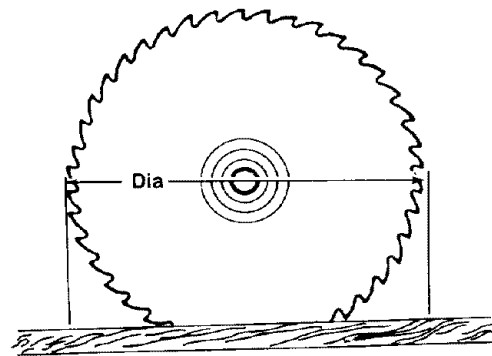

4. Workpieces that extend beyond the saw table can shift, twist, rise up from the table, or fall as they are cut. Support workpiece with table extensions the same height as the saw table.

5. To prevent tipping, support outer ends of extensions with sturdy legs or an outrigger.

6. Do not use another person to help support workpieces or to aid by pushing or pulling on workpieces, because these actions can cause kickback. Use table extensions.

7. Use clamps or vice to hold workpiece. It's safer than using your hands.

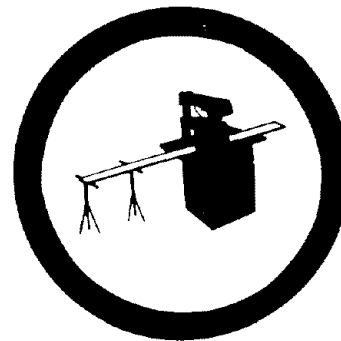

Blade Safety Instructions

1. Use only blades marked for at least 3450 rpm.
2. Use only 10" or smaller diameter blades.
3. Use blades for their recommended cutting procedures.
4. Keep blade sharp and clean.

5. Do not overtighten blade nut because blade collar could warp.

6. Do not turn saw on and off in rapid sequence because blade can loosen.

7. Blade should stop within 15 seconds after saw is switched off. If blade takes longer, the saw needs repair. Contact Sears Service Center.

Safety

On-Product Safety Labels

There are several safety labels on the saw. They alert the user to hazards explained in the manual and remind the user how to avoid the hazard.

Note where they are located on the saw. Read and follow the safety information and instructions in these labels. Refer to the manual for detailed explanations and instructions.

On the **outfeed side of the guard** is this safety label to alert you to **wrong way feed**:

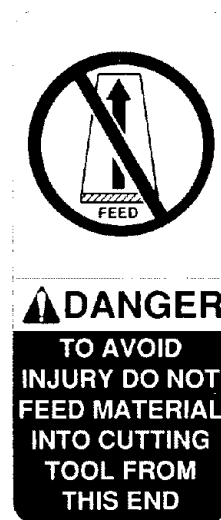

On the **infeed side of the guard** is this safety label to alert you to **kickback**, and to remind you to **lower the guard nose (hold down)** for ripping:



On the **side surface of the motor**, visible from the infeed side when the saw is in a rip position, is this safety label to alert you to **outfeed zone hazard**:

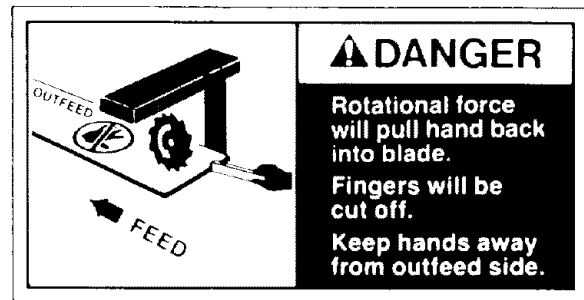

Near the saw handle is this safety label to alert you to **thrown objects** and to remind you to **wear safety goggles**:



On the **bottom surface of the motor**, visible when the cutting tool is horizontal, is this safety label to alert you **use a guard when edge molding**, and to **position cutting tool behind fence**: (see Accessories Section)

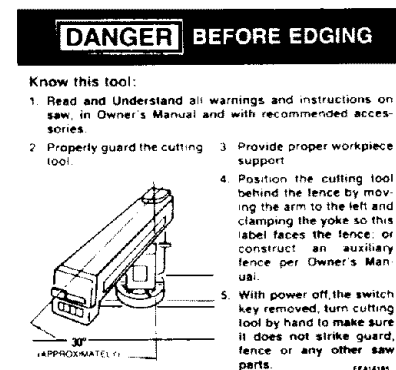

On the **front panel** is this **general safety instruction label**:

SAFETY INSTRUCTIONS

1. Read manual before using saw.
2. Wear safety goggles that meet ANSI Z87.1 standards.
3. Do not do freehand cuts.
4. Push carriage to full rear position after each cross cut.
5. Know how to reduce the risk of kickback. See instructions for ripping.
6. When ripping use push stick when blade is set 2 inches or more from fence.
7. When ripping use push block and auxiliary fence when blade is set between 1/2 and 2 inches from fence. Do not make rip cuts narrower than 1/2 inch.
8. Keep hands out of path of blade.
9. Do not reach around saw blade.
10. Turn power off and wait for blade to stop before adjusting or servicing.

Assembly

Identify Parts

The following parts are included:

Note: Before beginning assembly, check that all parts are included. If you are missing any part, do not assemble saw. Contact your Sears Service Center to get the missing part. Sometimes small parts can get lost in packaging material. Do not throw away any packaging until saw is put together. Check packaging for missing parts before contacting Sears. A complete parts list (Repair Parts) is at the end of the manual. Use the list to identify the number of the missing part.

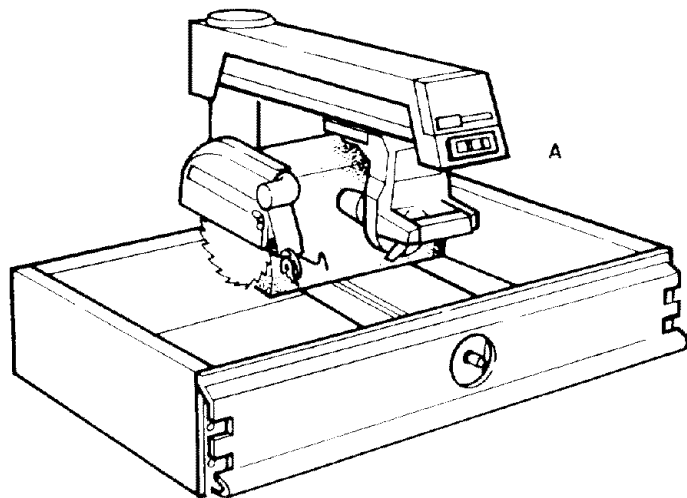

All models include:

- A. Basic Saw Assembly 1
- B. Rear Table 1
- C. Spacer Table 1
- D. Fence (wooden) 1
- E. Front Table 1
- F. Trim Cap 2
- G. Cabinet Box 1
- H. Loose Parts Bags *

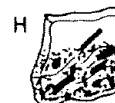
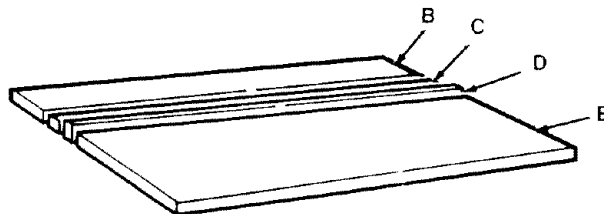

Only models with casters include:

- I. Caster/Foot Bag or Box 1

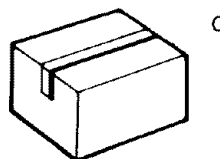

Only model with drawers includes:

- J. Drawer Box 1

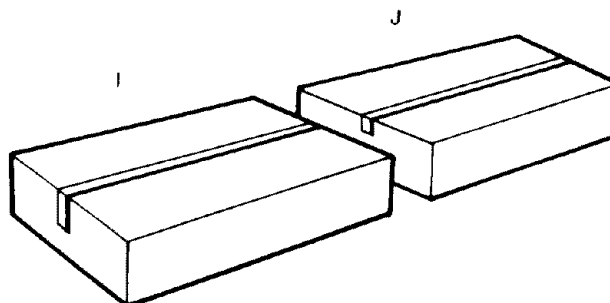

*Number varies; bags can contain other smaller bags. **Note:** To make assembly easier, keep contents of each bag together, and separate from contents of other bags.

Assembly

All models include: (When three numbers are given, the first is for the door model with casters, the second is for the door model without casters, and the third is for the drawer model.)

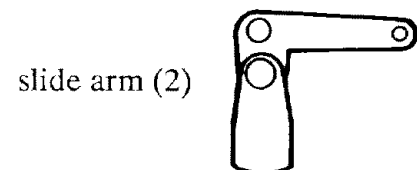
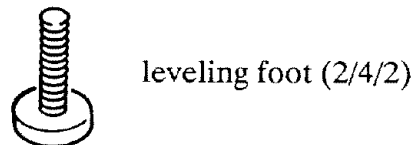
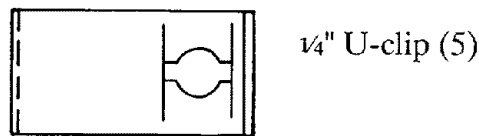
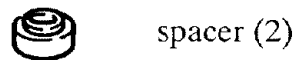
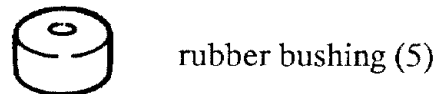
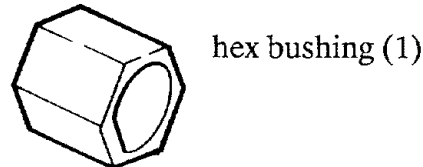
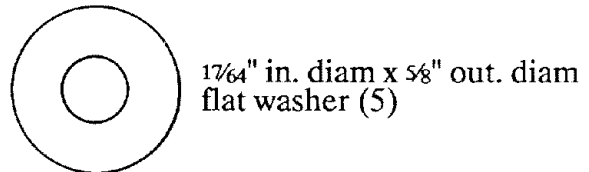
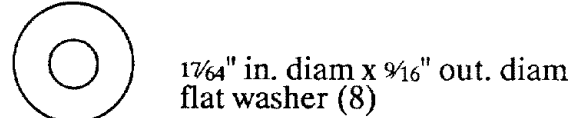
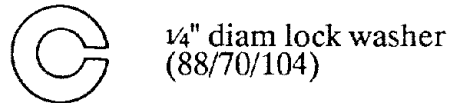
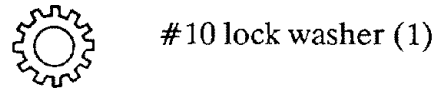
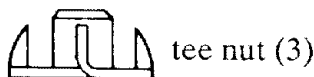
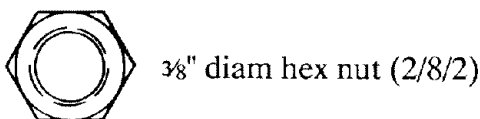
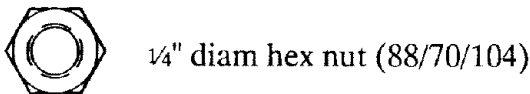
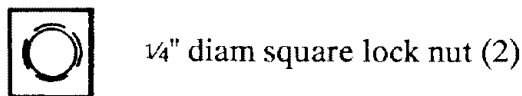
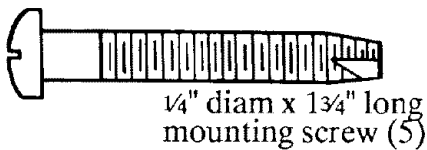
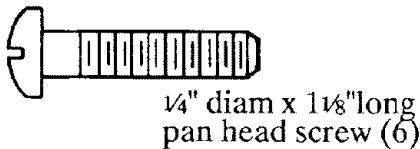
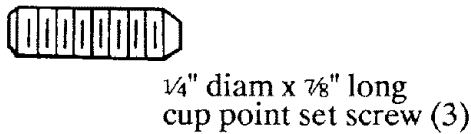
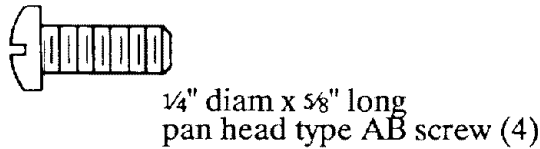
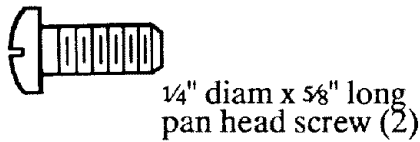
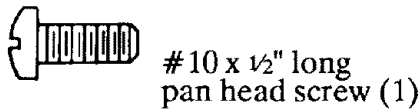
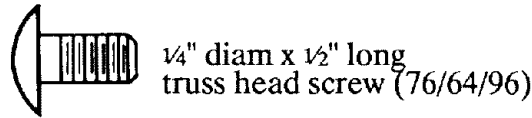

Assembly

All models include:

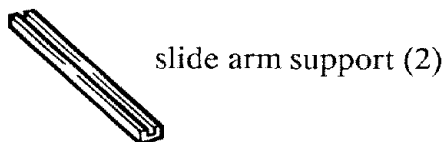

slide arm support (2)



lock handle (2)

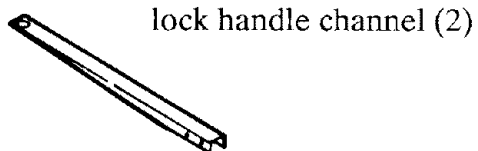

lock handle channel (2)

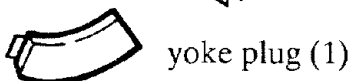

yoke plug (1)



yellow key (1)

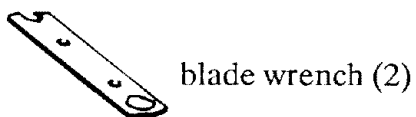

blade wrench (2)

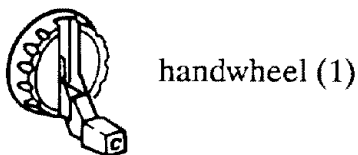

handwheel (1)

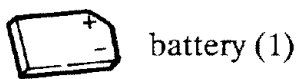

battery (1)

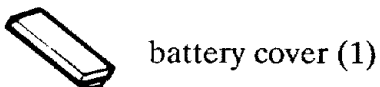

battery cover (1)

Only the door model with casters and the drawer model include:

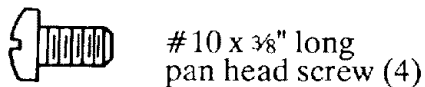

#10 x $\frac{3}{8}$ " long
pan head screw (4)

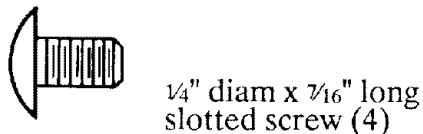

$\frac{1}{4}$ " diam x $\frac{7}{16}$ " long
slotted screw (4)

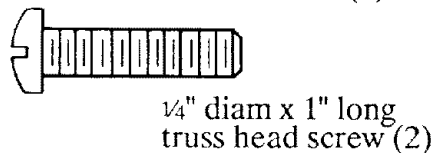

$\frac{1}{4}$ " diam x 1" long
truss head screw (2)

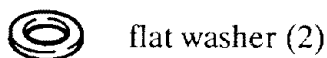

flat washer (2)

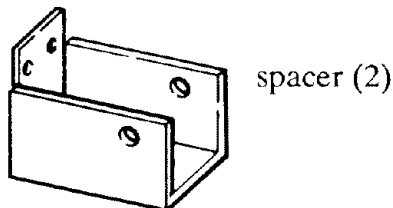

spacer (2)

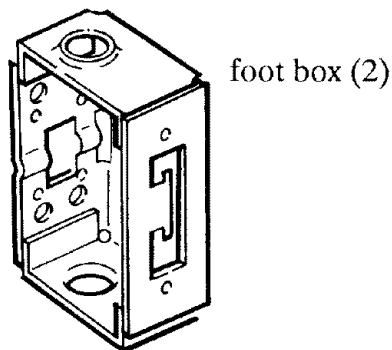

foot box (2)

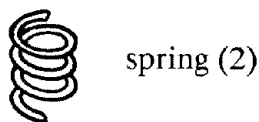

spring (2)

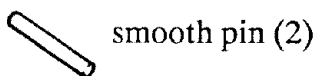

smooth pin (2)

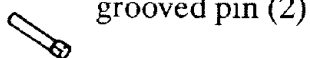

grooved pin (2)

Assembly

Only the door model with casters and the drawer model include:

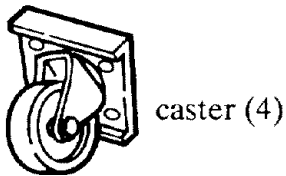
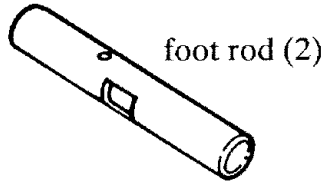
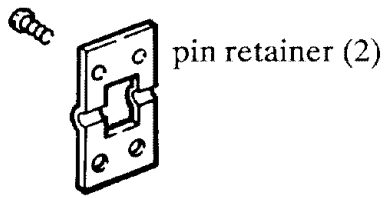

Only the drawer model includes:

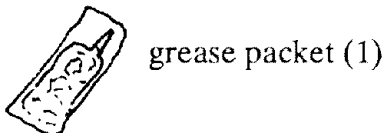
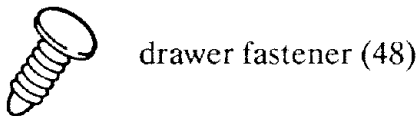

Only the door models include:

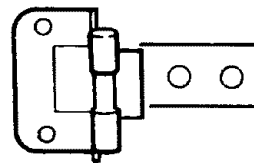
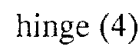
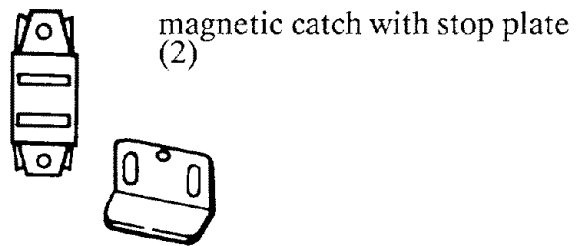
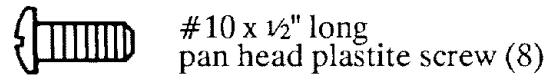
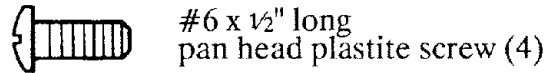
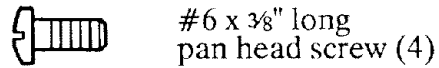

Tools Needed for Assembly

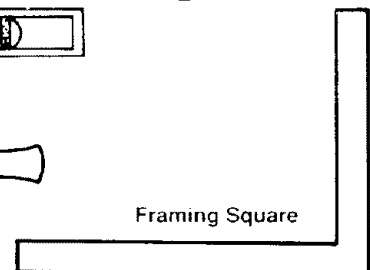
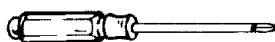
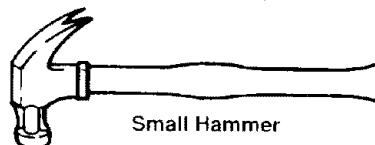
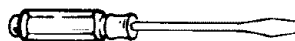
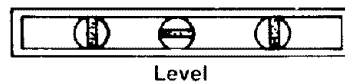
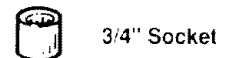
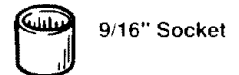
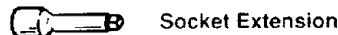

Assembly

Assembly Steps

It is important for your safety and to get accurate cuts that you put the saw together according to these instructions.

Note: *This manual covers three models. Depending on the model saw, you will be instructed to skip some steps, or do extra steps. The differences have to do with whether the cabinet has doors or drawers, and whether or not it has casters.*

Follow these steps **in order**.

Build Cabinet Base

1. Set out:

- bottom shelf
- front shelf stiffener
- under support
- lower support
- rear shelf stiffener
- four corner brackets
- sixteen $\frac{1}{4}$ " diam x $\frac{1}{2}$ " long truss head screws
- sixteen $\frac{1}{4}$ " diam lock washers
- sixteen $\frac{1}{4}$ " diam hex nuts.

2. Put bottom shelf upside down so long edge of raised (rear) side points down.

3. Put front shelf stiffener inside and against front edge of shelf.

4. Put under support on shelf so holes in end of support line up with two center holes in front shelf stiffener.

5. Put lower support under shelf so holes line up with holes in under support. **Note:** *Angled end of lower support will stick out from front of shelf.*

6. Place rear shelf stiffener so two center holes line up with holes in under support and ends are inside shelf edges.

7. Insert screws through eight holes shown. On end of each screw put washer, then nut, and wrench tighten.

WARNING

Plugging in saw during assembly can result in electrical shock, or severe cuts from contact with spinning blade.

Do not plug in saw at any time during assembly.

Plug in saw only when it is to be used.

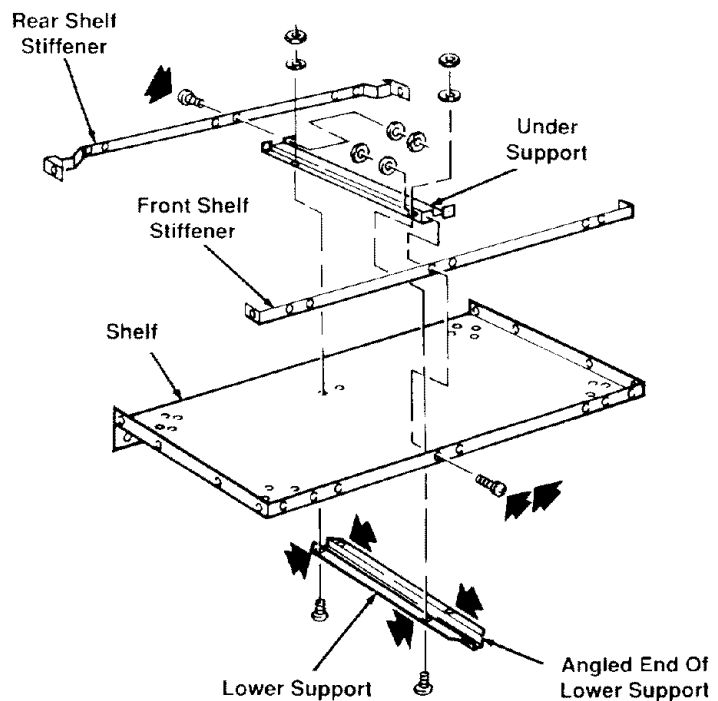
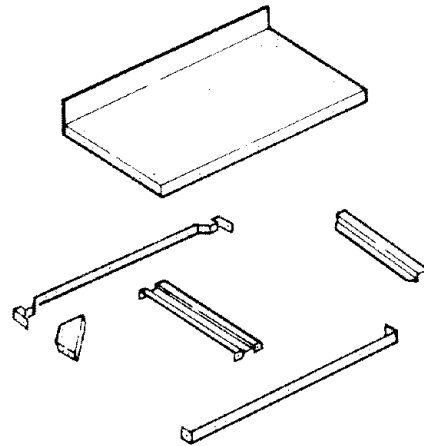

Assembly

8. Put corner bracket in each corner, so edges point up. Attach brackets to long sides of shelf: use two screws per bracket (*insert screws through shelf*); on end of each screw put washer, then nut, and wrench tighten. **Note:** *Screws for short sides will be installed later.*

Attach Casters (Only Models with Casters; Door Model without Casters: Go to "Assemble Side Panels")

1. Set out:

- four casters
- sixteen $\frac{1}{4}$ " diam x $\frac{1}{2}$ " long truss head screws
- sixteen $\frac{1}{4}$ " diam lock washers
- sixteen $\frac{1}{4}$ " diam hex nuts.

2. Attach one caster to each corner bracket: use four screws per caster (*insert screws through shelf*); on end of each screw put washer, then nut, and wrench tighten.

Build Foot Assemblies

1. Set out:

- two foot boxes
- two foot levers
- two foot rods
- two pin retainers
- two grooved pins
- two smooth pins
- two washers
- two springs
- two leveling feet
- four #10 x $\frac{3}{8}$ " long pan head screws
- two $\frac{3}{8}$ " diam hex nuts.

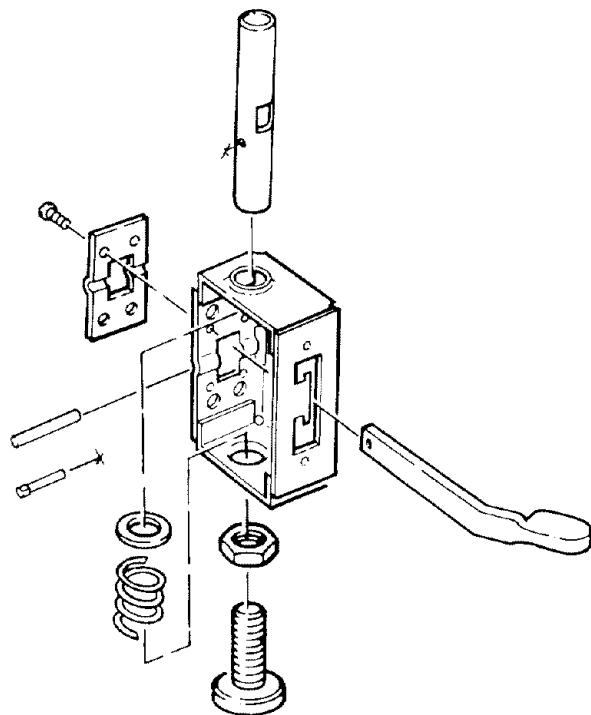
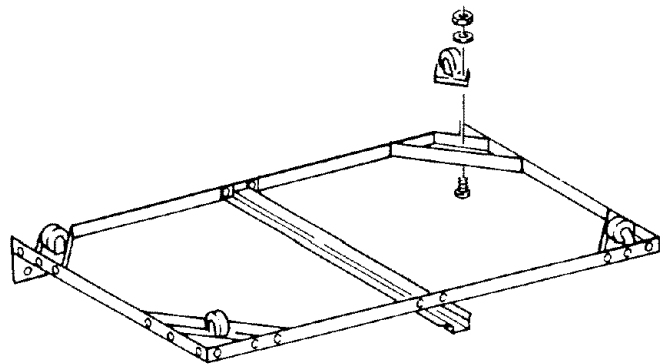
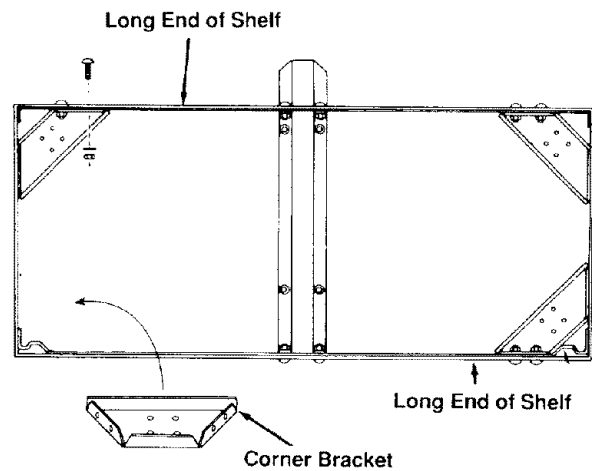

Assembly

2. Place one foot box so C-shaped opening faces you and closed side is on your left.

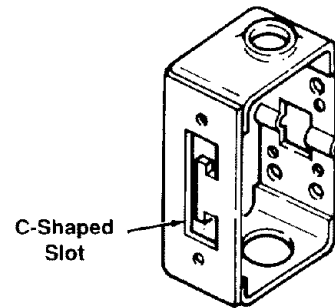

3. With threaded end of foot rod facing down, and smaller square opening facing you, put rod through top opening of foot box, and slide half way down into box.

4. Put grooved pin through hole in foot rod so grooved end faces out.

5. On end of foot rod put washer then spring. Push rod all the way down through spring.

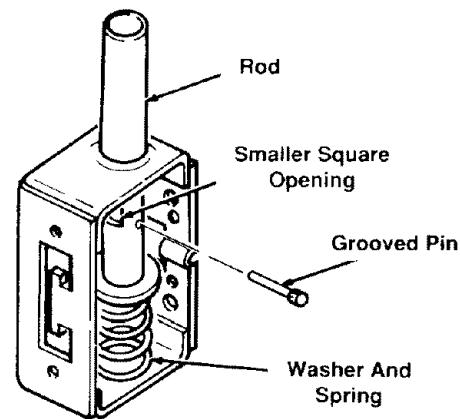

6. With lever pointing towards left, put foot lever through upper opening of "C", through rod, and out other end of foot box. Apply a few drops of SAE 10W-30 motor oil to area where lever and rod meet.

7. Put smooth pin through hole at end of foot lever.

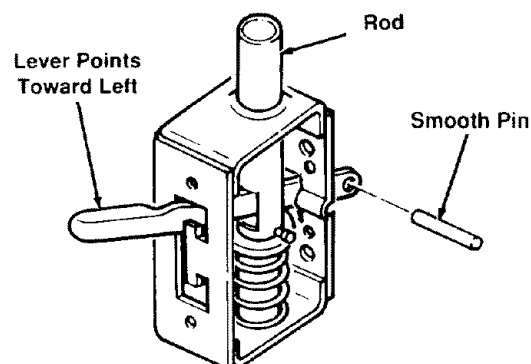

Assembly

8. Pull foot lever forward until smooth pin sits in groove of foot box. Attach pin retainer to rear of foot box: use two screws (insert screws through two smaller holes of retainer; make sure smaller holes are on top).

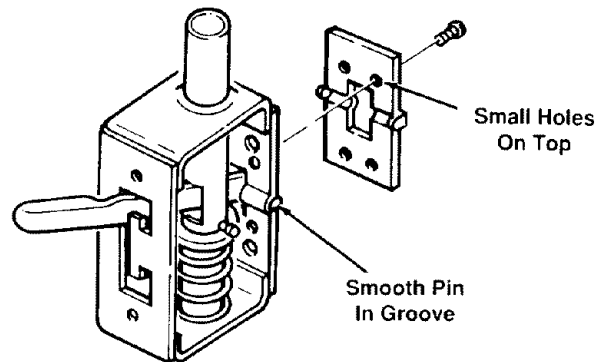

9. Screw nut to within $\frac{1}{2}$ " of bottom of leveling foot. Screw leveling foot into rod until nut meets foot box. This completes left foot assembly.

10. Repeat steps to build right foot assembly. Begin with closed side of foot box to your right (step 2). Have lever point toward right (step 6).

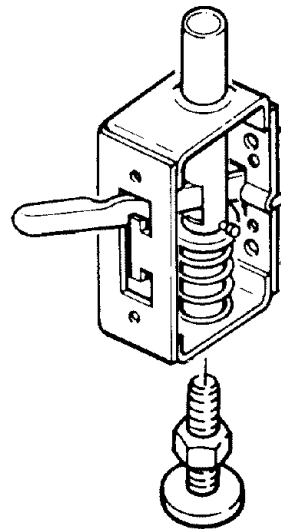

Attach Foot Assemblies

1. Set out:
 - right side panel
 - left side panel
 - four $\frac{1}{4}$ " diam x $\frac{7}{16}$ " long slotted screws.

2. Push foot lever on **right** foot assembly down into lower opening of "C" to lock foot assembly.

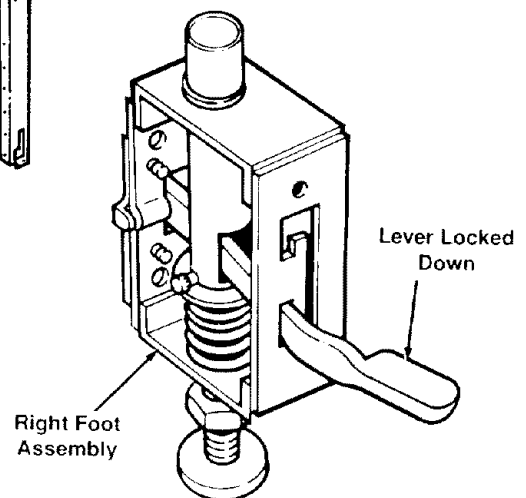
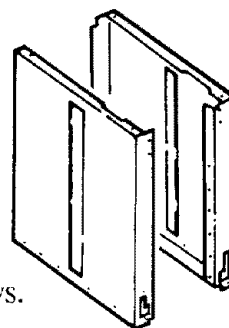

Assembly

3. Identify right side panel by locating letter "R" stamped near center of rear edge.
4. Put right foot assembly inside **front** edge of right side panel, so foot lever comes through "J" slot. Use two screws to attach foot assembly to panel (*insert screws through side panel*).
5. In similar way, attach **left** foot assembly to left side panel.

Assemble and Install Slide Brackets (Only Drawer Model; Door Model: Go to "Attach Door Hinges")

1. Set out:
 - twelve outer brackets
 - twelve center slides
 - three rear supports
 - grease packet
 - twenty $\frac{1}{4}$ " diam x $\frac{1}{2}$ " long truss head screws
 - twenty $\frac{1}{4}$ " lock washers
 - twenty $\frac{1}{4}$ " diam hex nuts.
2. Grease top and bottom of center slides.
3. Make twelve slide brackets: insert a center slide all the way into each of 12 outer brackets, then slightly pull back on center slide to make sure stop tabs are engaged.

4. Attach three slide brackets to **left** side of one rear support, in holes indicated: use one screw per slide bracket (*insert screws through larger hole in slide bracket*); on end of each screw put washer, then nut, and wrench tighten.

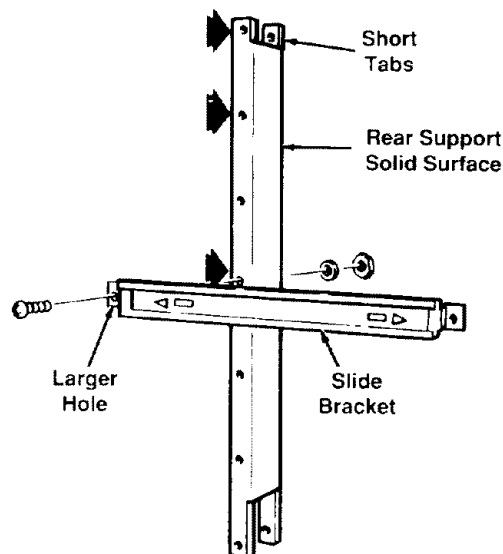
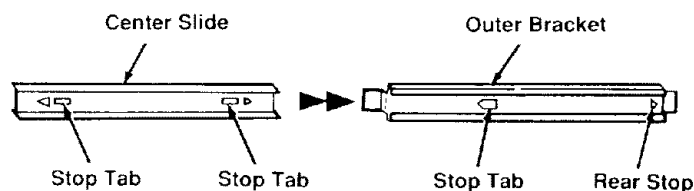
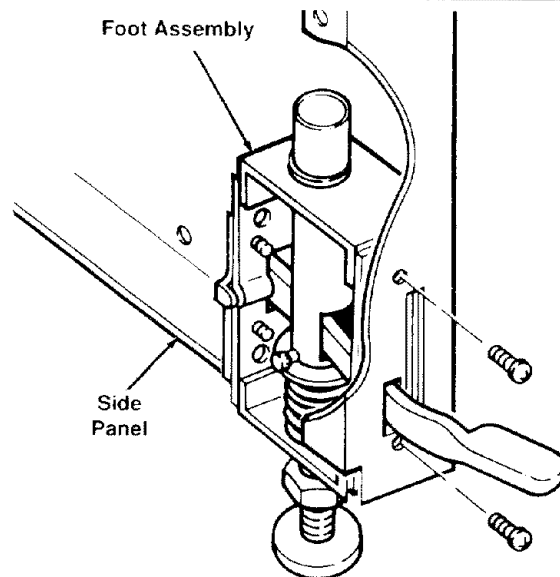

5. Position rear support, with slide brackets attached, inside **right** side panel, so short tabs point up, and solid surface faces front.

6. Attach rear support to side panel: use two screws (insert screws through side panel); on end of each screw put washer, then nut, and wrench tighten.

7. Attach slide brackets to front inside edge of side panel: use three screws (insert screws through slide brackets); on end of each screw put washer, then nut, and wrench tighten.

8. Repeat steps 4-7, installing slide brackets to **right** side of another rear support and attaching rear support, with slide brackets attached, to **left** side panel.

9. Attach four slide brackets to remaining rear support, one on each side of center hole and one on each side of second hole from top: use four screws (insert screws through larger hole in slide bracket); on end of each screw put washer, then nut, and wrench tighten. *Set this rear support aside for later use. Remaining two slide brackets will be installed later.*

10. Go to "Attach Side Panels to Bottom Shelf."

Assemble Side Panels(Only Door Model without Casters)

1. Set out:

- right side panel
- left side panel
- two spacers
- four leveling feet
- four 1/4" diam x 1/2" long truss head screws
- four 1/4" diam lock washers
- four 1/4" diam hex nuts
- eight 3/8" diam hex nuts.

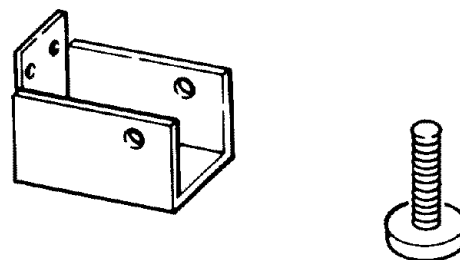
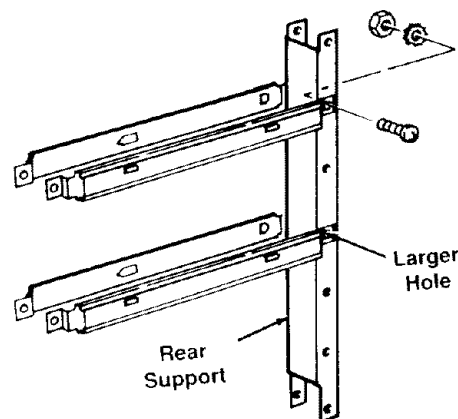
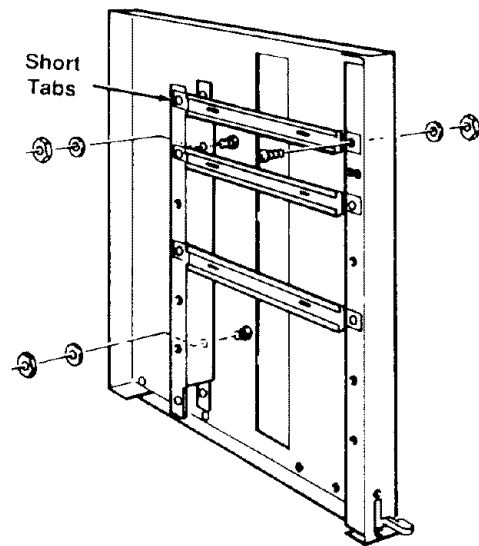

Assembly

2. Identify right side panel by locating letter "R" stamped near center of rear edge. Position right side panel upright, so "J" slot is at bottom and facing you.
3. Put spacer inside front bottom edge of side panel, so two holes face "J" slot and large hole rests on bottom edge.
4. Attach spacer to side panel: use two screws (*insert screws through side panel*); on end of each screw put washer, then $\frac{1}{4}$ " nut, and wrench tighten.
5. In similar way, attach spacer to left side panel.
6. Screw $\frac{3}{8}$ " nut onto each leveling foot.
7. Insert leveling foot through bottom hole at front and rear of each side panel. On end of each leveling foot put another $\frac{3}{8}$ " nut and finger tighten until it meets surface.

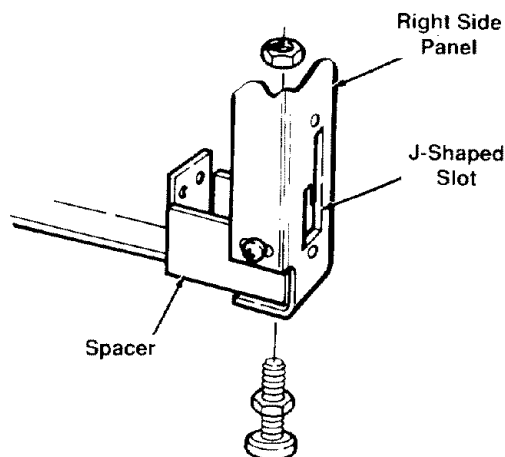

Attach Door Hinges

1. Set out:
 - four hinges
 - eight $\frac{1}{4}$ " diam x $\frac{1}{2}$ " long truss head screws
 - eight $\frac{1}{4}$ " diam lock washers
 - eight $\frac{1}{4}$ " diam hex nuts.
2. Attach two hinges to each side panel: use two screws per hinge (*insert screws through hinge*); on end of each screw put washer, then nut, and wrench tighten.

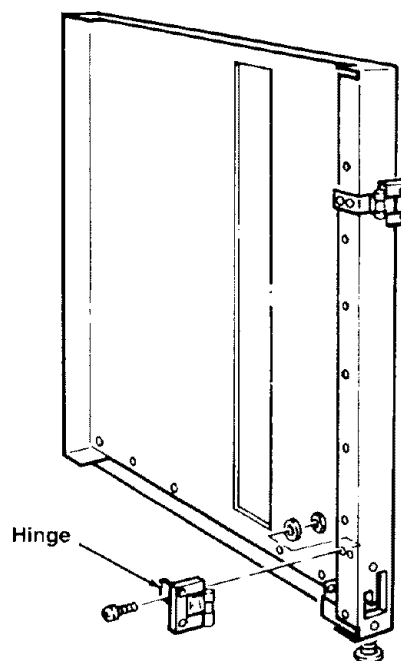

Attach Side Panels to Bottom Shelf

1. Set out:
 - eight $\frac{1}{4}$ " diam x $\frac{1}{2}$ " long truss head screws
 - eight $\frac{1}{4}$ " diam lock washers
 - eight $\frac{1}{4}$ " diam hex nuts.
2. Put bottom shelf on floor so bottom surface faces you and angled end of lower support points up. Slide right side panel into place so four holes in side panel line up with four holes in bottom shelf.
3. Attach panel to shelf: use four screws (*insert screws through side panel*); on end of each screw put washer, then nut, and wrench tighten.
4. In similar way, attach left side panel.

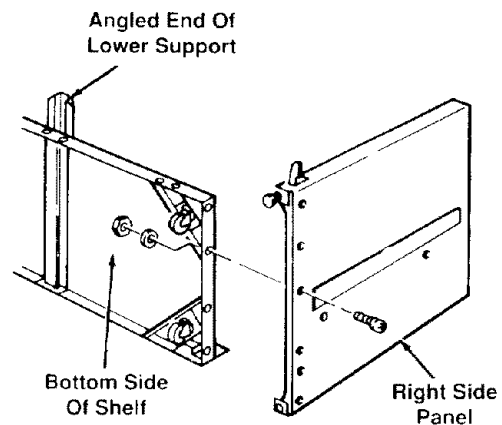

Attach/Install Spacers

Door Model WITHOUT Casters:

1. Set out:
 - two $\frac{1}{4}$ " diam x $\frac{1}{2}$ " long truss head screws
 - two $\frac{1}{4}$ " diam lock washers
 - two $\frac{1}{4}$ " diam hex nuts.
2. Attach spacers to bottom shelf: use one screw per spacer (*insert screw through spacer*); on end of screw put washer, then nut and wrench tighten.

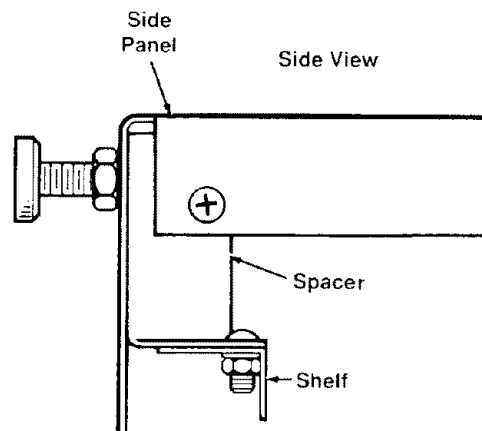

Door Model WITH Casters and Drawer:

1. Set out:
 - two spacers
 - two $\frac{1}{4}$ " diam x 1" long truss head screws
 - two $\frac{1}{4}$ " diam lock washers
 - two $\frac{1}{4}$ " diam hex nuts.
2. Push foot levers down and towards outside so they will release and unlock foot assemblies.

Assembly

3. Attach spacer between each foot assembly and bottom shelf: use one screw per spacer (*insert screw through foot assembly*); on end of each screw put washer, then nut, and wrench tighten.

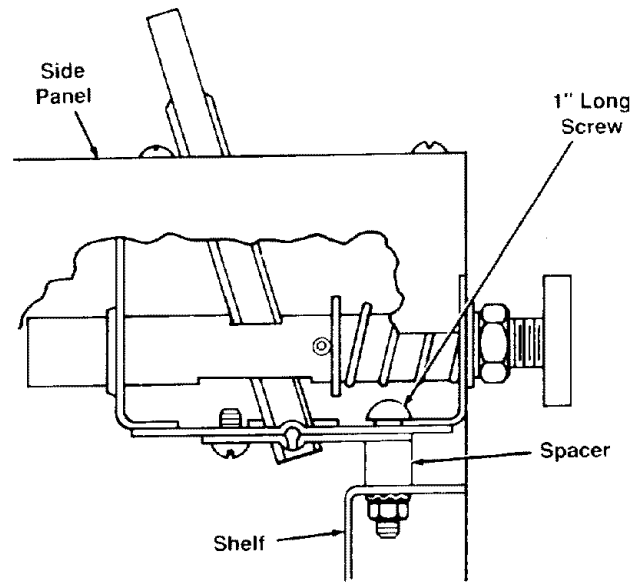

Attach Skirts

1. Set out:

- two skirts
- ten $\frac{1}{4}$ " diam x $\frac{1}{2}$ " long truss head screws
- ten $\frac{1}{4}$ " diam lock washers
- ten $\frac{1}{4}$ " diam hex nuts.

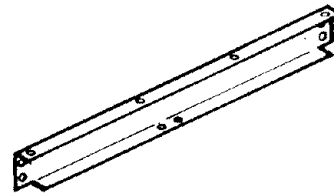

2. Turn cabinet right side up. Attach skirts, across front and rear of cabinet, to side panels: use four screws per skirt (*insert screws through skirt*); on end of each screw put washer, then nut, and finger tighten.

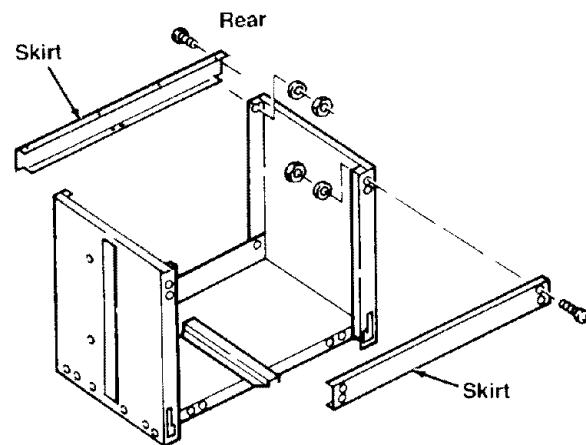

3. Put screw through hole at bottom rear of right side panel and through raised edge of bottom shelf. On end of screw put washer, then nut, and wrench tighten. Repeat for left side panel.

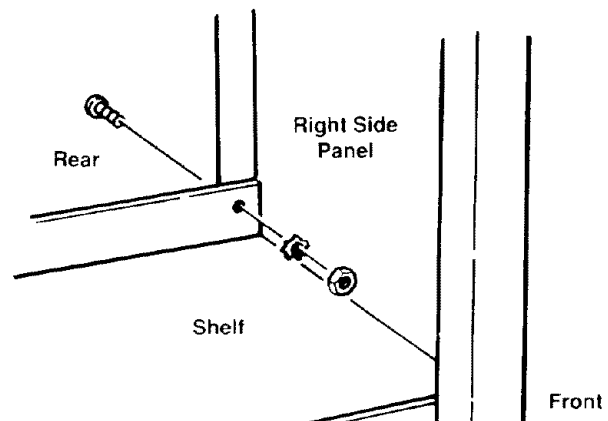

Finish Cabinet (Only Door Models; Drawer Model: Go to "Complete Center Slide Assembly")

1. Set out:

- upper support
- center support
- eight 1/4" diam x 1/2" long truss head screws
- eight 1/4" diam lock washers
- eight 1/4" diam hex nuts.

2. Rest center support on floor, solid surface down. Slide upper support into center support to form an "L" shaped assembly.

3. Attach center support to upper support: use two screws (*insert screws through long sides of center support*); on end of each screw put washer, then nut, and finger tighten.

4. Turn "L" shaped assembly 90° to right, so upper support is parallel to floor and solid surface is on top. Slide into front of cabinet, under front and rear skirts, so bottom of center support fits onto lower support.

5. Attach center and upper supports to front skirt: use two screws (*insert screws through upper support*); on end of each screw put washer, then nut and wrench tighten.

6. Attach upper support to rear skirt: use two screws (*insert screws through upper support*); on end of each screw put washer, then nut and wrench tighten.

7. Attach center support to lower support: tilt cabinet back; use two screws (*insert screws through sides of center support*); on end of each screw put washer, then nut and finger tighten.

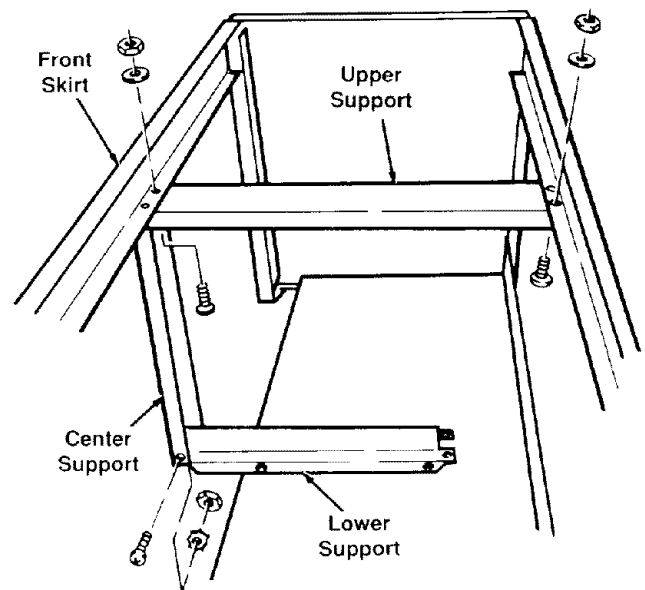
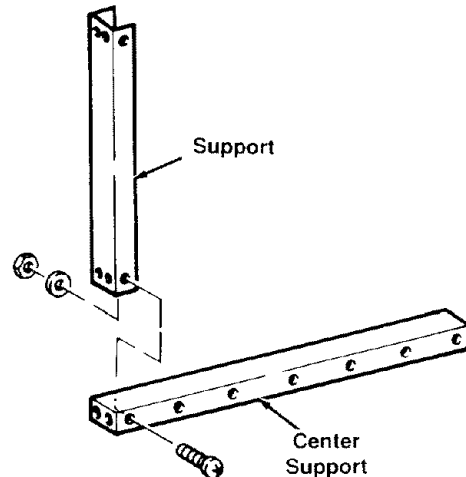
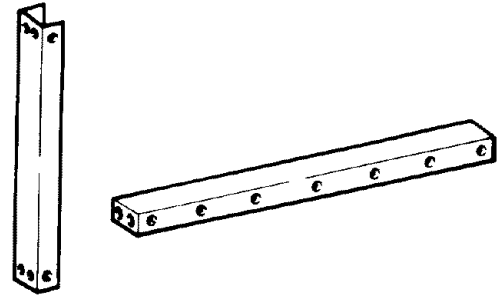

Assembly

Attach Doors

1. Set out:
 - two doors
 - two magnetic catches with stop plates
 - four #6 x 1/2" long pan head plastite screws
 - four #6 x 3/8" long pan head screws
 - eight #10 x 1/2" long pan head plastite screws.

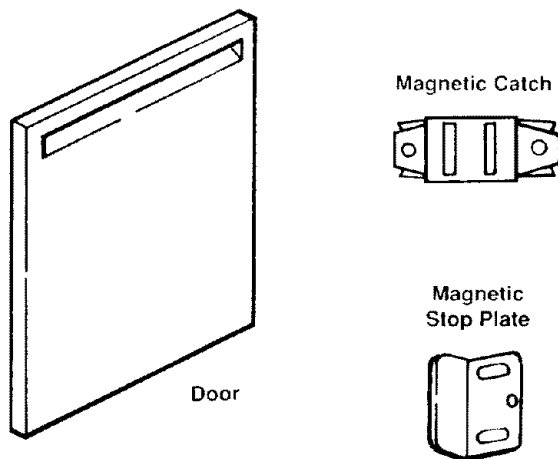

2. Put both doors face down on floor. Attach magnetic catch to inside surface of each door: use two #6 x 1/2" long screws per catch.

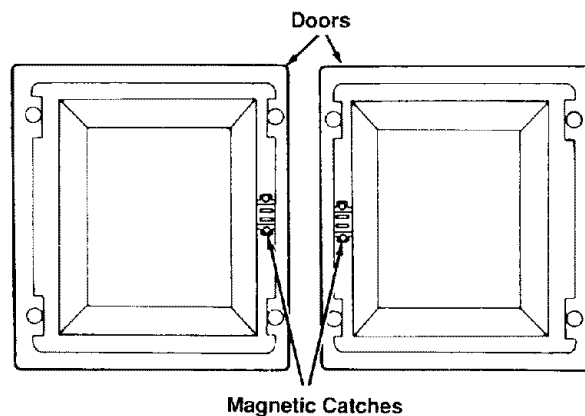

3. Attach magnetic stop plate to each side of center support: use two #6 x 3/8" long screws per stop plate (*insert screws through plate and into small holes*).
4. Attach doors to hinges on side panels: use four #10 x 1/2" screws per door.
5. Go to "Attach Handwheel".

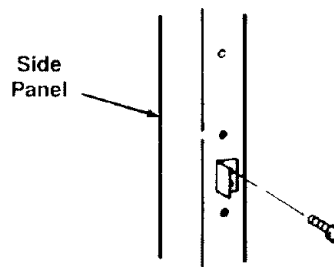

Complete Center Slide Assembly (Only Drawer Model)

1. Set out
 - center support
 - upper support
 - rear support with four slide brackets attached
 - two slide brackets
 - sixteen 1/4" diam x 1/2" long truss head screws
 - sixteen 1/4" diam lock washers
 - sixteen 1/4" diam hex nuts.

Assembly

2. Position rear support so **short tabs are at top**. Attach four slide brackets to center support (**make sure solid surface of support faces out**): use four screws (*insert screws through slide brackets*); on end of each screw put washer, then nut, and wrench tighten.

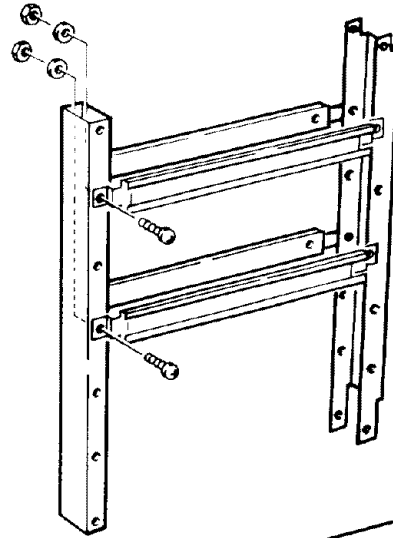

3. With solid surface on top, put upper support between rear and center supports, so it sits inside tabs of rear support and inside center support.

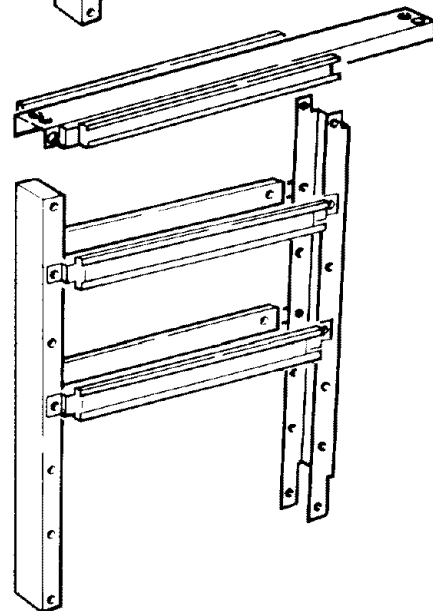

4. Attach two slide brackets at top: position them so larger holes line up on rear support; use two screws per bracket (*insert screws through slide bracket*); on end of each screw put washer, then nut, and wrench tighten.

5. Tilt center slide assembly and slide inside cabinet, under front and rear skirts, so center support rests on lower support.

6. Attach center slide assembly to front and rear skirts: use two screws per skirt (*insert screws through upper support*); on end of each screw put washer, then nut, and finger tighten.

7. Attach center and rear supports to lower support: use four screws (*insert screws through front and rear supports*); on end of each screw put washer, then nut, and wrench tighten.

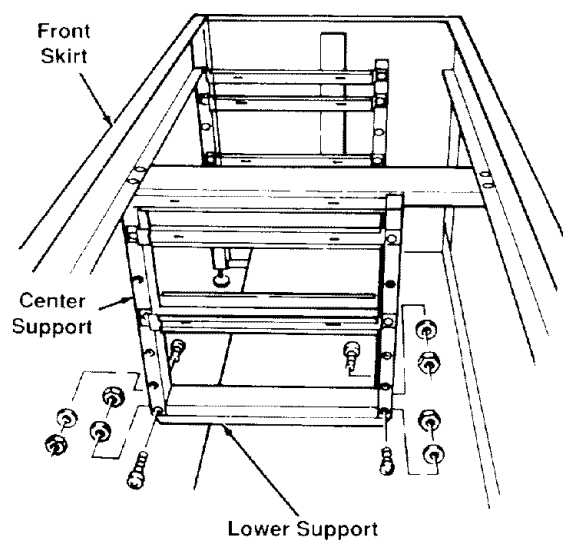

Assembly

Assemble Drawers

1. Set out:
 - two 10" drawers
 - two 6" drawers
 - two 3" drawers
 - six drawer fronts
 - forty-eight drawer fasteners.
2. Slide drawer fronts down onto drawers.
3. From inside drawer surface, push drawer fastener into each hole and into drawer front.
4. Set drawers aside for installation after saw has been mounted.

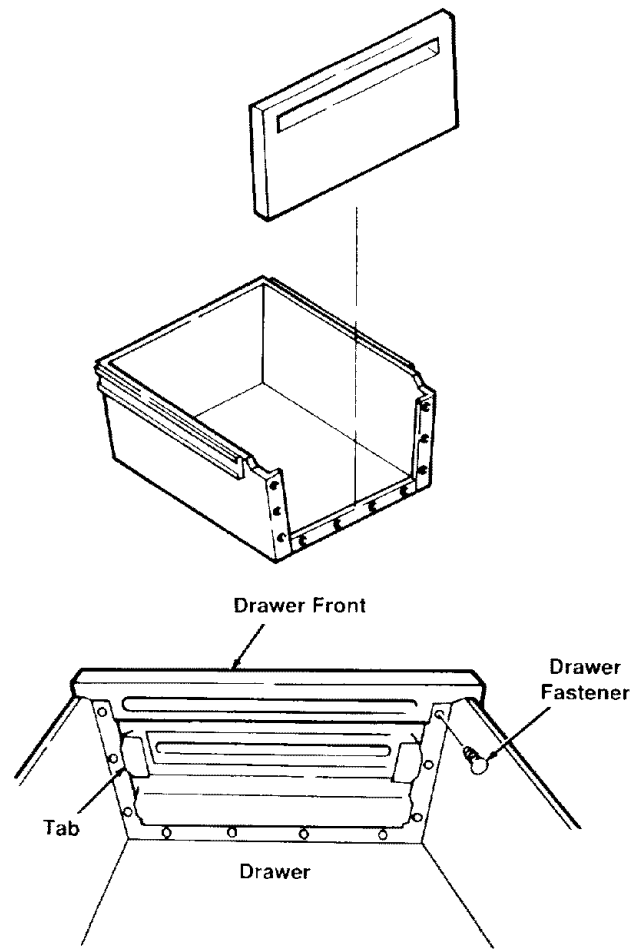

Attach Handwheel

1. Set out:
 - handwheel
 - #10 x 1/2" long pan head screw
 - #10 lock washer
 - hex bushing.
2. Put hex bushing into opening in back of handwheel.
3. Align hex bushing on elevation shaft.
4. Put washer on screw; put screw into hole in center of handwheel and tighten with screwdriver.

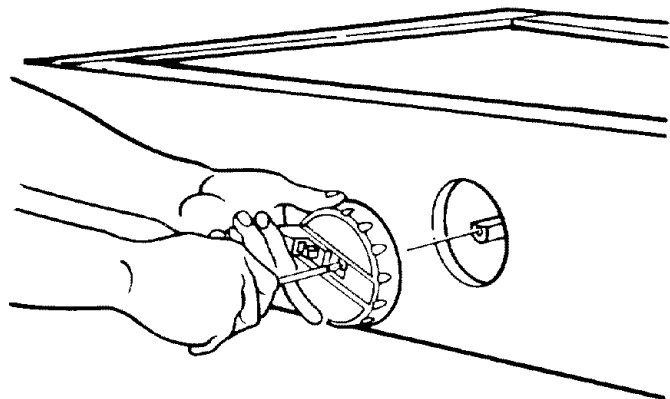

Mount Motor

1. Loosen guard clamp screw and lift guard off blade.

2. Use both blade wrenches in scissor action to loosen blade nut. **Note:** Arbor shaft has left-hand threads. Turn nut clockwise to loosen.

3. Remove and set aside nut, blade collars and blade. They will be re-installed later during alignment and adjustment.

4. Lock rip lock. Turn handwheel clockwise to raise radial arm about 3".

5. Remove styrofoam packing blocks, and clean small pieces of styrofoam off saw. Lift motor out of styrofoam base and set on center channel of saw. Remove three table sections and fence.

6. Remove lock nut and flat washer from motor support.

7. Slide bevel encoder to top position so it will fit into notch in plate index on motor.

8. Slide motor onto motor support. Make sure motor is firmly in place.

9. Re-install flat washer and lock nut. Tighten lock nut and at same time move bevel lock (located near saw handle) back and forth. Do not over tighten nut.

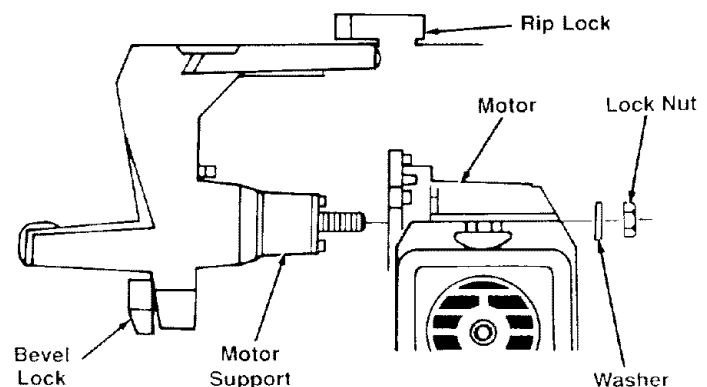
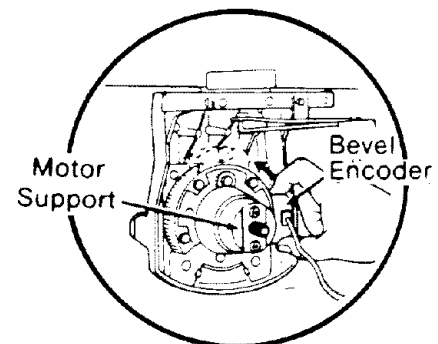
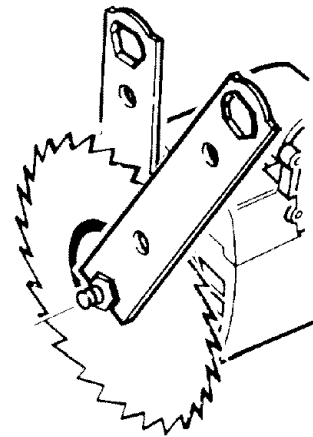
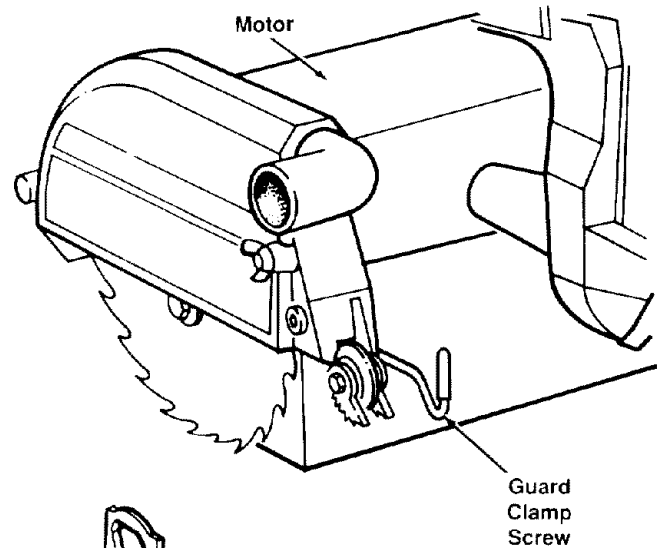

Assembly

10. Push bevel lock to left (locking direction) as far as it will go. Space between casting and bevel lock should be about $\frac{1}{16}$ ":

to increase space, unlock bevel lock then tighten lock nut on motor support;
to decrease space, unlock bevel lock then loosen lock nut on motor support.

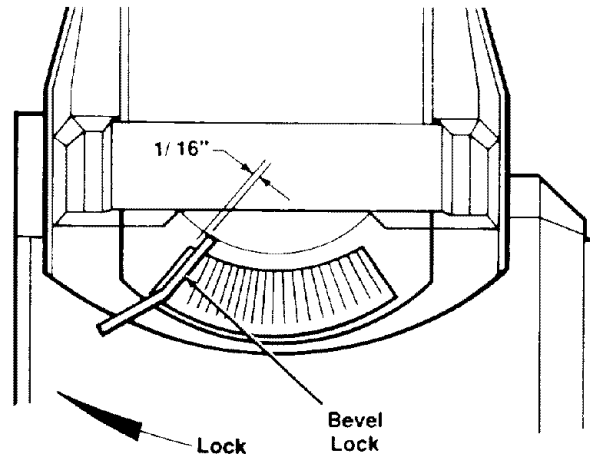

11. Lock bevel lock. With tabs on outside, insert one end of yoke plug into opening in blade carriage, just behind bevel lock. Push until plug snaps into place.

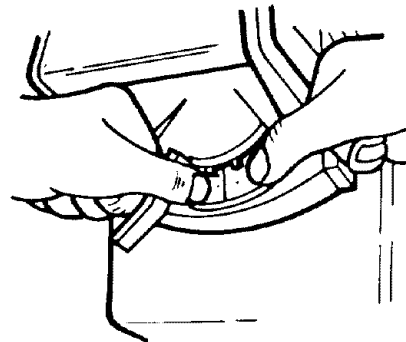

Mount Basic Saw Assembly

1. Set out:
 - basic saw assembly
 - eight $\frac{1}{4}$ " diam x $\frac{1}{2}$ " truss head screws
 - eight $\frac{1}{4}$ " diam lock washers
 - eight $\frac{1}{4}$ " diam hex nuts.
2. Lift saw assembly by front edge and column and place on cabinet so holes line up.
3. Attach saw to cabinet: use eight screws (*insert screws through saw frame*); on end of each screw put washer, then nut and wrench tighten.
4. Check and wrench tighten **all** nuts in cabinet.
5. Put saw in location where it will be used.

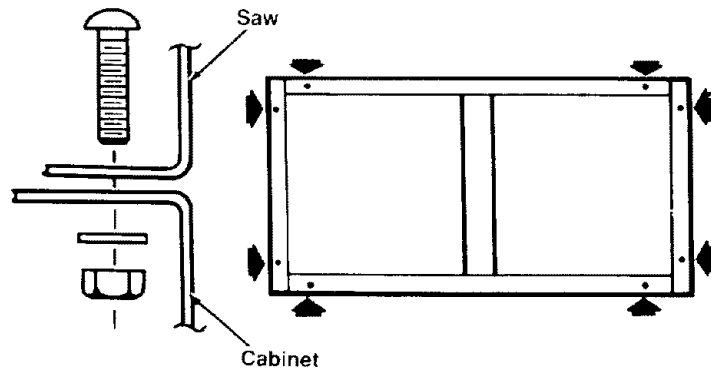

Adjust Leveling Feet

Note: *If cabinet has casters, lock foot assemblies and make sure front casters are slightly off floor before adjusting leveling feet.*

1. If cabinet rocks, adjust leveling feet so they rest on floor.
2. Rest a level on radial arm. If arm is level or slants forward, adjust leveling feet so arm slants slightly towards rear.
3. Only Door Model Without Casters: wrench tighten top nut on each leveling foot.

Attach Trim Caps

1. Line up plastic stubs on back of trim caps with holes on front corners of frame and snap into place.

Attach Lock Handle Channels

1. Set out:
 - two lock handle channels
 - two lock handles
 - four 1/4" diam x 1 1/8" long pan head screws
 - four 1/4" diam lock washers
 - four 1/4" diam hex nuts.
2. Insert lock handles through openings in front of saw.
3. Slide lock handle channel, open side facing down, onto each lock handle and attach: use two screws per channel (*insert screws through lock handle channel*); on end of each screw put washer, then nut and wrench tighten.

WARNING

Saw must slant slightly towards rear to keep blade carriage from rolling forward. Workpiece or saw can move unexpectedly if cabinet rocks. Fingers, hand or arm could be cut off by blade contact.

Adjust leveling feet before using saw.

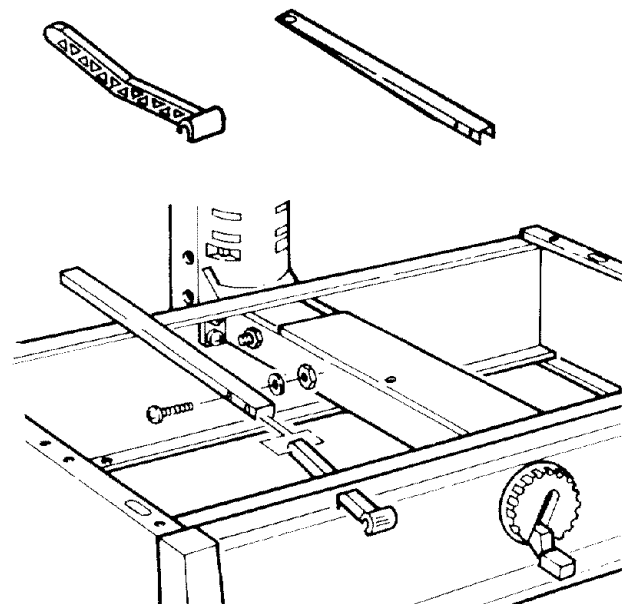
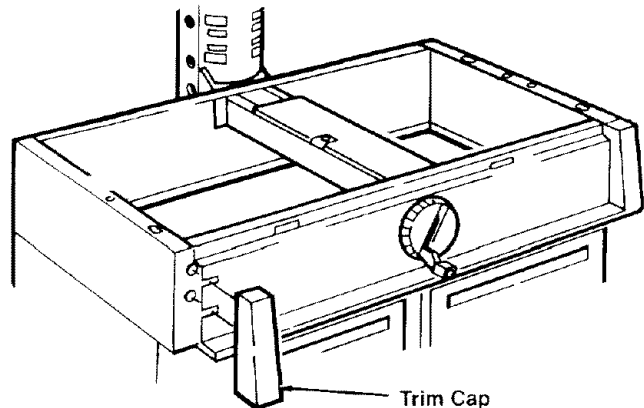

Assembly

Attach Slide Arm Supports

1. Set out:
 - two slide arm supports
 - four $\frac{1}{4}$ " diam x $\frac{5}{8}$ " long pan head type AB screws
 - front table.
2. Identify top and bottom of table: top has countersunk holes. Place table bottom side up.
3. Attach slide arm supports, solid sides down, to table: use two screws per support; tighten, but not fully, because support will have to be adjusted later.

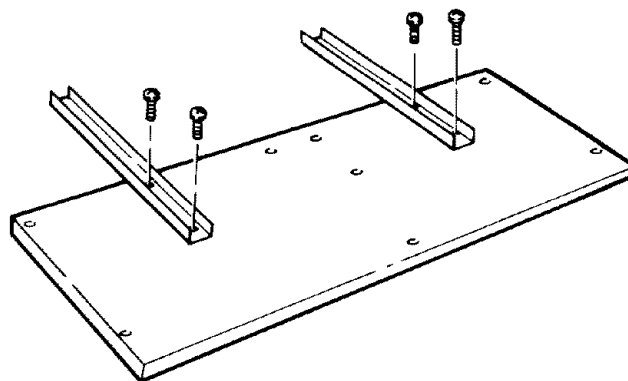

Install Front Table

1. Set out:
 - three tee nuts
 - five rubber bushings
 - five $\frac{1}{4}$ " U-clips
 - five $\frac{1}{4}$ " diam x $1\frac{3}{4}$ " long mounting screws
 - two $\frac{1}{4}$ " diam x $\frac{1}{2}$ " long truss head screws
 - three $\frac{1}{4}$ " diam x $\frac{7}{8}$ " long cup point set screws
 - five $1\frac{7}{64}$ " in. diam x $\frac{5}{8}$ " out. diam flat washers
 - two $1\frac{7}{64}$ " in. diam x $\frac{9}{16}$ " out. diam flat washers
 - two $\frac{1}{4}$ " diam lock washers
 - two $\frac{1}{4}$ " diam hex nuts.

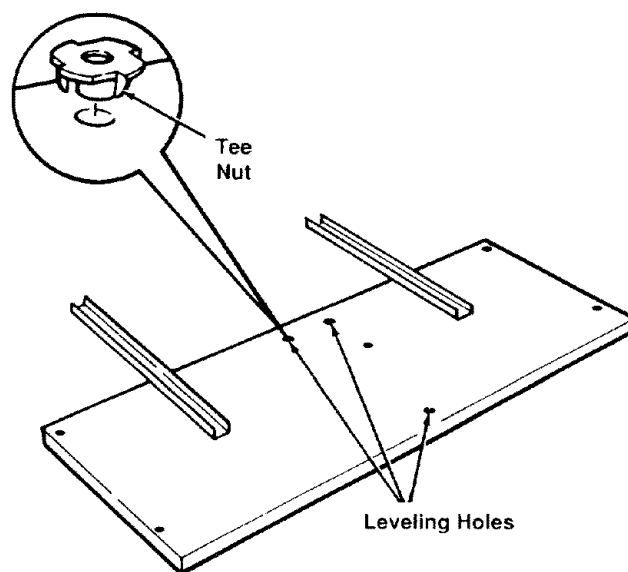

2. With front table still bottom side up, hammer tee nut into each leveling hole.

Assembly

3. Snap one U-clip onto left side of center channel, so hole lines up with hole in channel. Snap remaining four U-clips over holes in sides of saw frame.

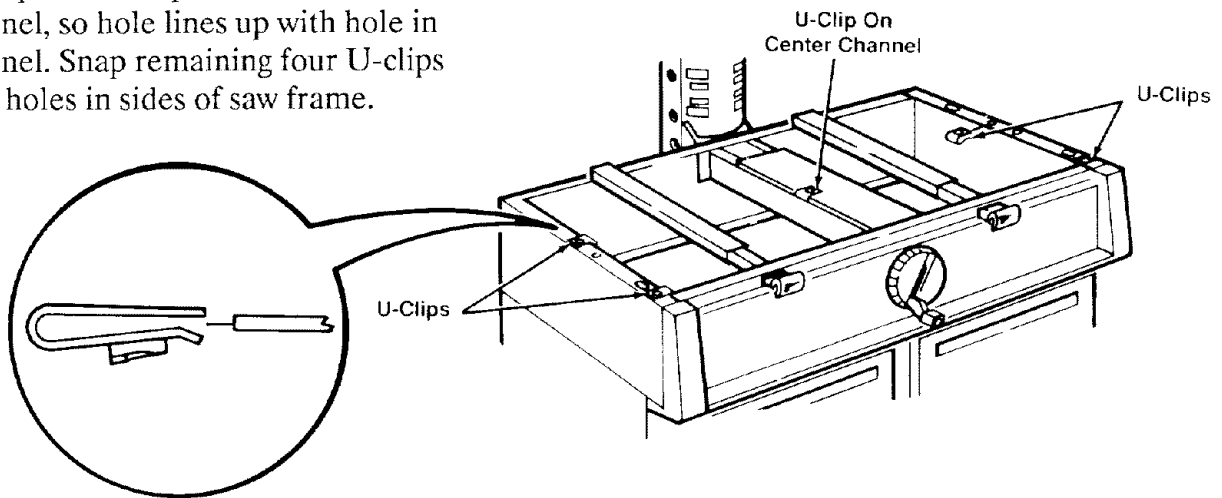

4. Put $1\frac{1}{64}$ " in. diam x $\frac{5}{8}$ " out. diam washer on each $1\frac{3}{4}$ " long mounting screw.

5. Stand table on edge. Put mounting screws, with washers attached, into each of five mounting holes (*insert screw through table top*); on end of each screw put rubber bushing.

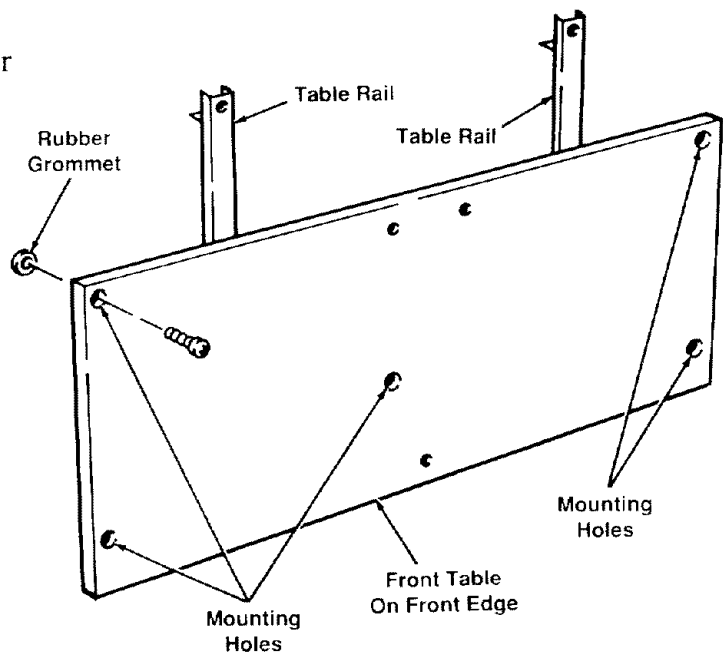

6. Place table, top side up, on saw so mounting screws line up with holes in U-clips. **Note:** *Table will extend about 1" beyond trim caps.*

7. Tighten mounting screws into U-clips until heads just touch table. **Note:** *Make sure rubber bushings are not squeezed.*

8. Start cup point set screw through each leveling hole and into tee nuts. Use $\frac{1}{8}$ " hex wrench to tighten screws until flush with table.

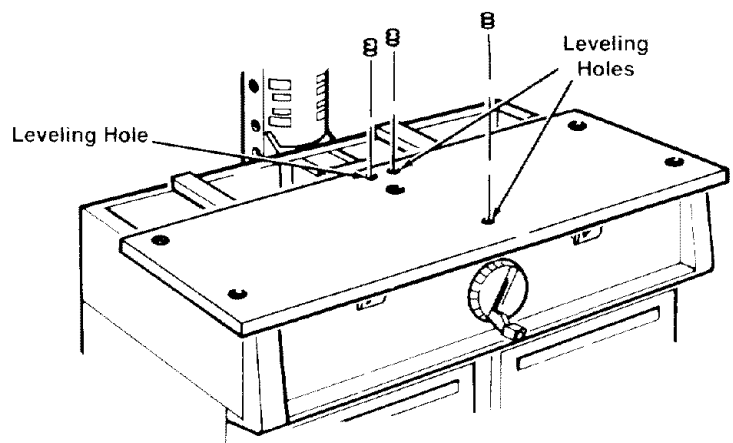

Assembly

9. Push slide arm supports until "L" brackets are flush with saw frame, then attach: use one $\frac{1}{2}$ " long truss head screw per support (*insert screw through "L" bracket*); on end of each screw put $\frac{17}{64}$ " in. diam x $\frac{9}{16}$ out. diam flat washer, then lock washer, then nut and wrench tighten.

10. From underneath table, tighten pan head screws in each slide arm support.

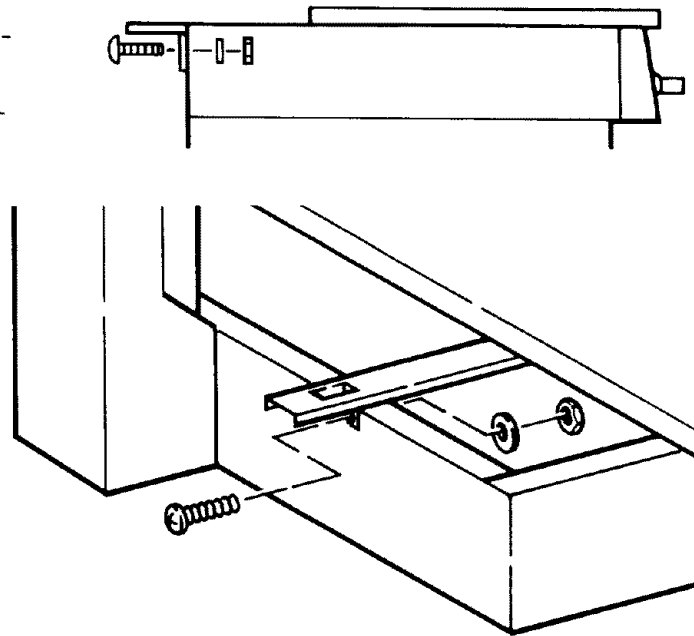

Assemble Table Lock Mechanism

1. Set out:

- two slide arms
- two spacers
- two $\frac{1}{4}$ " diam x $1\frac{1}{8}$ " long pan head screws
- two $\frac{1}{4}$ " diam x $\frac{5}{8}$ " long pan head screws
- six $\frac{17}{64}$ " in. diam x $\frac{9}{16}$ out. diam flat washers
- two $\frac{1}{4}$ " diam lock washers
- two $\frac{1}{4}$ " diam hex nuts
- two $\frac{1}{4}$ " diam square lock nuts.

2. Snap spacer into each slide arm.

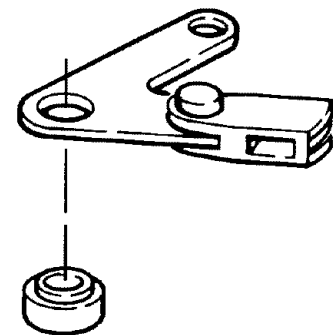

3. Drop slide arm into each slide arm support so "nose" faces front of table and "arm" extends over lock handle channel.

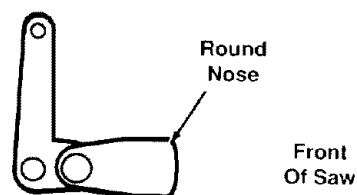

4. Attach slide arms to slide arm supports: use one 1 $\frac{1}{8}$ " long screw per slide arm; put flat washer on screw; insert screw through slide arm; on other end of screw put another flat washer; put screw through slide arm support; on end of screw put lock washer, then hex nut and wrench tighten.

5. Attach slide arms to lock handle channels: use one $\frac{5}{8}$ " long screw per slide arm; insert screw through slide arm; on end of screw put flat washer; put screw through lock handle channel; on end of screw put square lock nut and tighten.

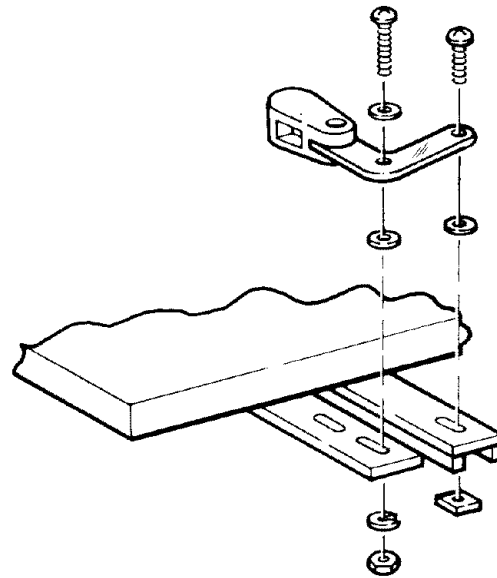

Install Drawers (Only Drawer Model)

1. Slide each drawer into place and push all the way in.
2. Pull each drawer out as far it will go. They should not come all the way out. If any do, use screwdriver to bend out stop tabs on slide brackets and re-test drawer.

To Remove Drawers (Only Drawer Model)

1. Use screwdriver to push in one stop tab on right slide bracket and at same time pull drawer out slightly.
2. Repeat with left slide bracket and pull drawer all way out.

Alignment and Adjustment

Go to Alignment and Adjustment Section and follow all instructions. You cannot use the saw until it is aligned and adjusted. It may be helpful to read the Controls Section before proceeding with alignment and adjustment.

Remaining parts will be installed in Digital Display Section.

Controls

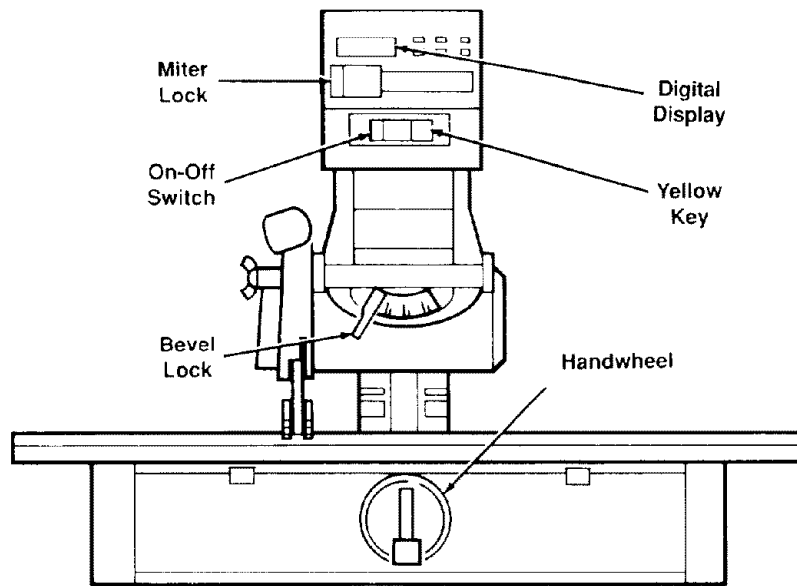

<u>Control</u>	<u>Function</u>	<u>Operation/Comments</u>
Miter Lock	Frees radial arm to move; locks in any desired position; pre-set indexed positions at 0°, 45°, -45°	Pull out and towards right to unlock, push to lock <i>Hold in unlocked position while moving arm</i>
On-off Switch	Turns motor on/off	Pull on, push off <i>Requires yellow key</i>
Yellow Key	Allows saw to be switched on	Insert into on-off switch <i>Remove after turning saw off</i>
Bevel Lock	Frees motor to rotate; locks in any desired position; pre-set indexed positions at 0°, 45°, -45°, 90°, -90°	Move towards right to unlock, towards left to lock <i>Support motor before unlocking because it can swing down quickly. Hold in unlocked position while moving motor</i>
Handwheel	Raises/lowers radial arm	Turn clockwise to raise, counterclockwise to lower <i>To fold handle into wheel, squeeze red plastic ears and push handle; pull handle out until ears click into place</i>
Table Lock	Frees table sections to allow fence changing	Pull to unlock, push to lock
Digital Display	Tells position of blade and arm at touch of a button	<i>See Digital Display Section</i>

Controls

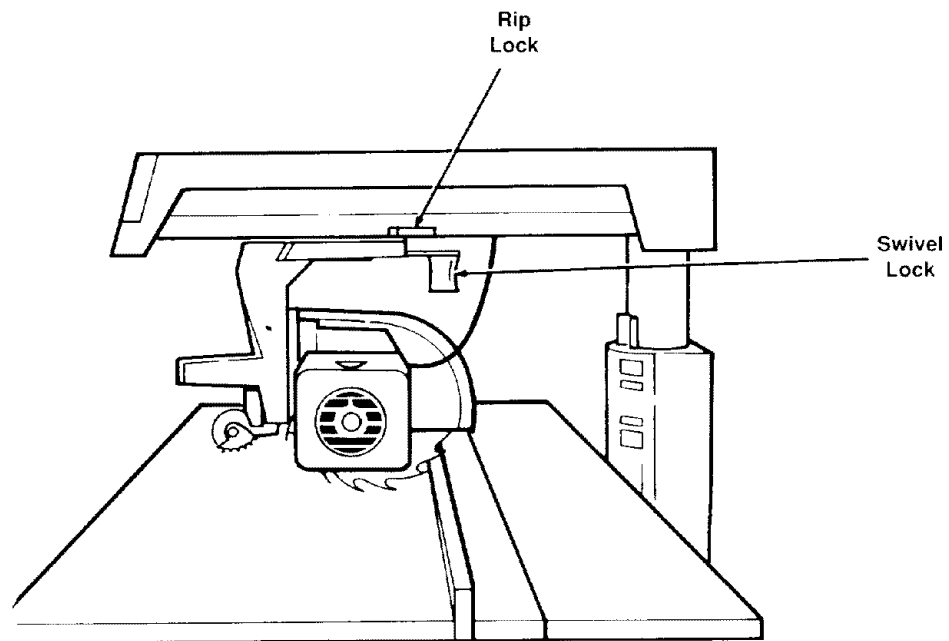

Control

Function

Operation/Comments

Rip Lock

Frees carriage to move along radial arm; locks in position

Pull to unlock, push to lock
Lock before ripping

Swivel Lock

Frees blade carriage to rotate between rip and crosscut positions; locks in position

Pull to unlock; push to lock
Hold in unlocked position while moving blade carriage

Controls

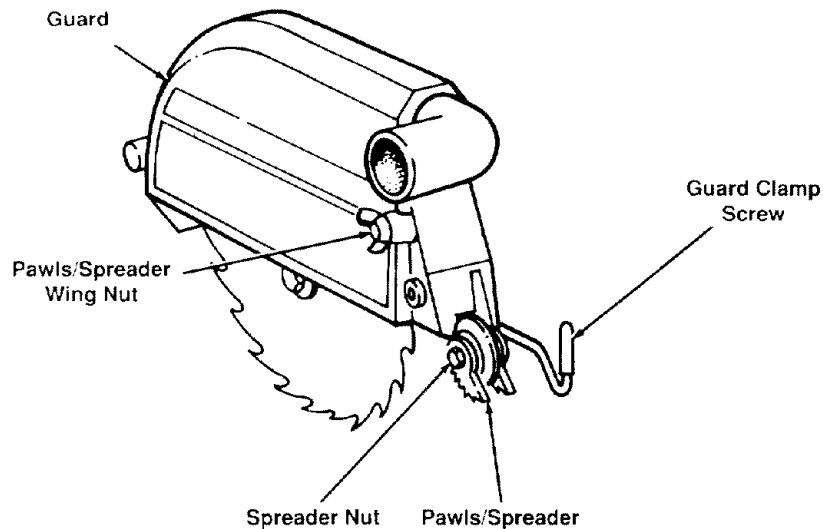

<u>Control</u>	<u>Function</u>	<u>Operation/Comments</u>
Guard	Partially protects against blade contact; keeps workpiece from fluttering during ripping; acts as saw-dust deflector	Lock in level position for crosscut; for ripping, rotate until guard nose just clears top surface of workpiece, then lock in place <i>See Ripping Set-Up for details and illustrations</i>
Guard Clamp Screw	Frees guard to rotate about blade	Turn counterclockwise to loosen, clockwise to tighten
Pawls/Spreader Wing Nut	Frees pawls/spreader to move up and down	Turn counterclockwise to loosen, clockwise to tighten
Spreader Nut	Frees pawls/spreader to move side to side	Loosen to make adjustment, then tighten. <i>For safety reasons spreader must be in line with blade. See Alignment: Spreader to Blade</i>
Pawls/Spreader	Reduce kickback by keeping kerf open (spreader function); slow or stop kickback by digging into workpiece (pawls function)	Set as unit, so pawl is level on workpiece and spreader rides in kerf. <i>For safety reasons set pawls/spreader before ripping. See Ripping Set-Up for details and illustrations</i>

Alignment and Adjustment

This section applies to all three models covered by this manual. The saw and blade must be aligned correctly for two reasons:

- 1) to prevent binding of the blade and workpiece, which can cause jams, kick-backs, or thrown workpieces;
- 2) to make accurate cuts.

Alignment and Adjustment Steps

The following alignments and adjustments **must be made in order**. If you miss an adjustment, you must go back, make the missed adjustment, and repeat all steps from that point on.

These adjustments are like fine tuning a piece of equipment. Often, a series of steps must be repeated more than once in order to get the adjustment right.

There are many adjustments to make. Because some adjustments may be awkward, you may want to ask someone to help you.

Before you start, make sure the framing square is true.

Adjust Column Support

The combined goal of this adjustment is:

- a) to eliminate looseness between the column and column support, and
- b) to make raising and lowering the radial arm a smooth and firm action.

1. Lock radial arm at 0° miter.
2. Raise and lower radial arm a few turns in each direction. Movement should be smooth but firm.

If movement seems difficult, slightly loosen (less than $\frac{1}{8}$ turn) four bolts at rear of column support.

WARNING

Plugging in saw during alignment could result in accidental start-up and severe cuts from contact with spinning blade.

Do not plug in saw at any time during alignment or adjustment.

Plug in saw only when it is to be used.

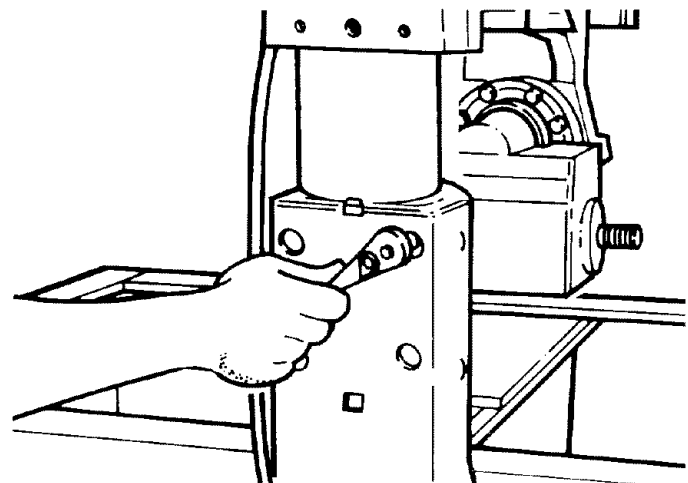
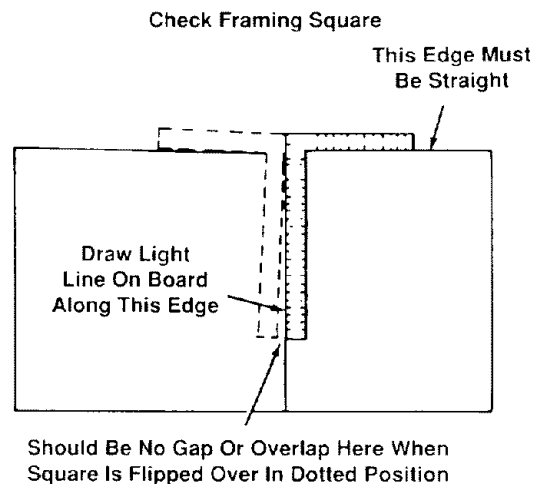

Alignment and Adjustment

3. Feel for movement between column and column support: place index finger of one hand against column and column support; use other hand to push end of radial arm side to side and up and down.

If there is no movement, no further adjustment is needed.

If there is movement, slightly tighten (less than $\frac{1}{8}$ turn) four bolts at rear of column support.

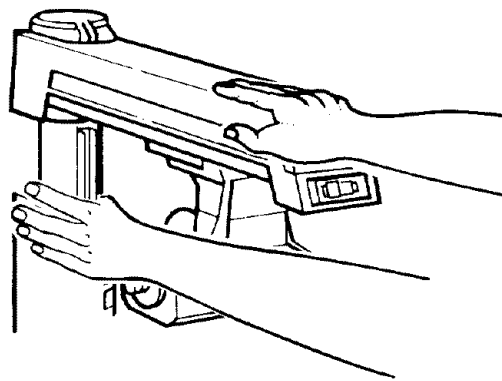

Level Front Table

The goal of this adjustment is to make the front table flat and parallel to the radial arm, so that when the blade is installed, there will be equal clearance between the blade and table at all points.

1. Loosen all three cup point set screws until they do not touch base. Make sure five mounting screws are snug but not overtightened.
2. Raise radial arm about 3". Lock motor at 90° bevel (arbor shaft points down).
3. Draw two lines on table, one over each lock handle channel/slide arm support area.
4. Unlock rip lock and pull blade carriage forward as far as it will go.
5. Unlock miter lock, move radial arm until center of arbor shaft is directly over a line. Mark that point on line.
6. Push blade carriage to rear and mark similar point at rear of line. Mark other line in same way.
7. Find lowest of four marked points: measure distance between arbor shaft and table (*greatest distance identifies lowest point*). Lower arbor shaft until it just clears table at lowest point.

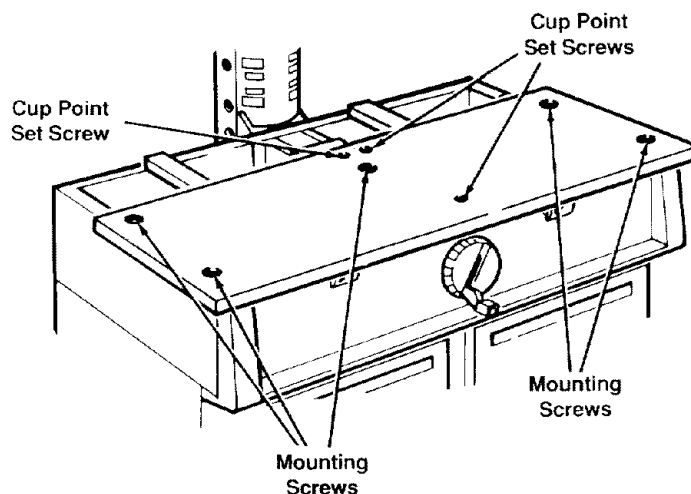

Alignment and Adjustment

8. **Without changing elevation of radial arm**, position arbor shaft, in turn, over each of three remaining marked points. Lower or raise table until arbor shaft just clears table at those points:

to lower table: tighten mounting screws
to raise table: tighten cup point set screws.

Check for equal clearance at all four points.

9. Place rear table on its edge, across front of table. Check for gap between surfaces. **If there is more than $\frac{1}{32}$ " gap**, close gap by tightening center mounting screw and/or cup point set screws.

10. Similarly, check for gap across rear of table and adjust as needed.

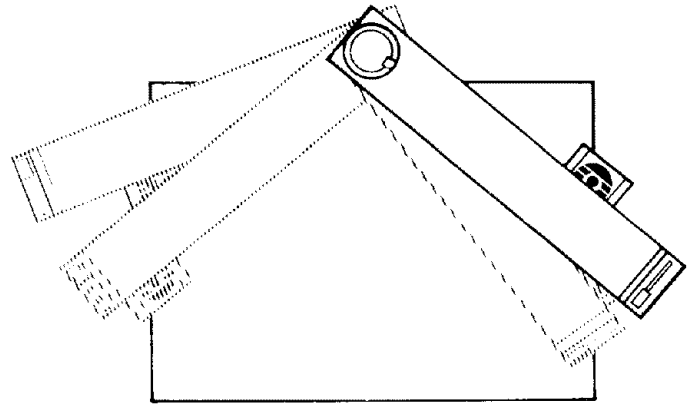

Square Crosscut Travel

The goal of this adjustment is to make accurate crosscuts. To do so, the radial arm must be perpendicular to the fence, otherwise, there will be a slight miter angle in all crosscuts.

1. Lock radial arm at 0° miter.
2. Lock motor at 90° bevel (arbor shaft points down).
3. Lower radial arm until arbor shaft is slightly above table.
4. Unlock rip lock. Move blade carriage until arbor shaft is at rear edge of front table.
5. Place framing square so long side is off rear edge of table, and short side just touches arbor shaft. Hold square in place, grasp saw handle and pull blade carriage forward. Arbor shaft should just touch square at all points. If it does, no adjustment is needed.

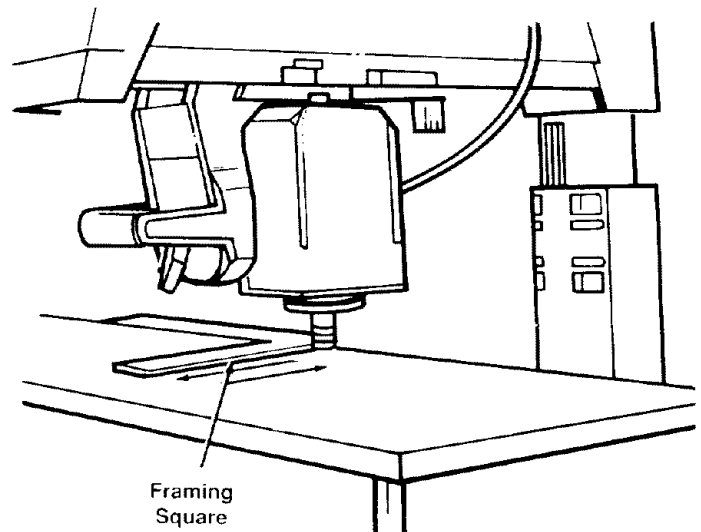

Alignment and Adjustment

6. If arbor shaft moves into or away from square, adjust radial arm:

to move radial arm toward right, loosen two socket head screws on right, then tighten two screws on left. **Note:** *Loosen and tighten screws equally.*

to move radial arm toward left, loosen two socket head screws on left, then tighten two screws on right. **Note:** *Loosen and tighten screws equally.*

7. When arbor shaft just touches square at all points, raise and lower radial arm a few times. If movement is difficult, slightly and equally loosen all four socket head screws.

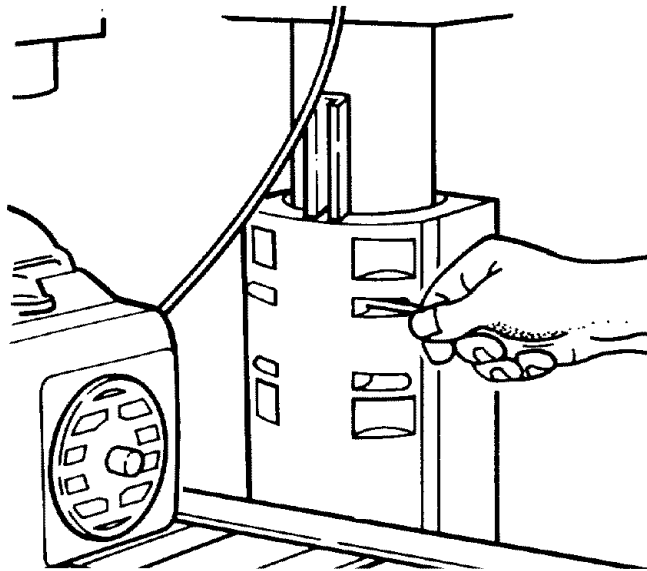

Install Blade

1. Lock rip lock.
2. Raise radial arm. Lock motor at 0° bevel (arbor shaft horizontal).
3. On arbor shaft put blade collar, then blade, then second blade collar, then blade nut. **Note:** *Concave surfaces of blade collars rest against blade. Make sure directional arrow on blade is on outside and points clockwise.*
4. Use blade wrenches in scissor action to tighten nut. **Note:** *Arbor shaft has left-hand threads. Turn nut counterclockwise to tighten. Do not overtighten nut because this can cause blade collar to warp and blade to wobble during cutting.*

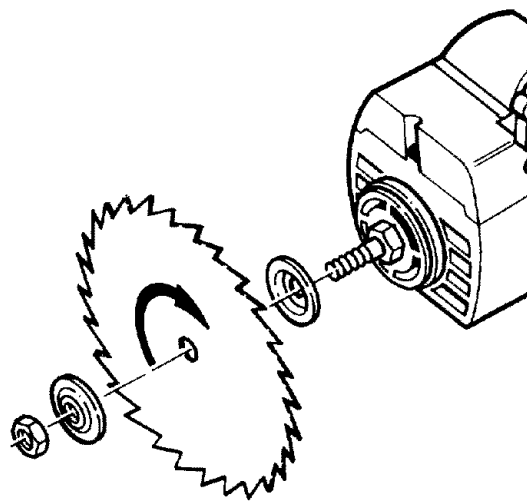

Square Blade to Table for Crosscutting

The goal of this adjustment is to make the blade perpendicular to the table so that crosscuts will be accurate; otherwise all crosscuts will have a slight bevel angle.

1. Lower blade until it just clears table. Lock bevel, miter, rip, and swivel locks.

Alignment and Adjustment

2. Place square so long edge rests on table and short edge rests against blade surface, not on a tooth.

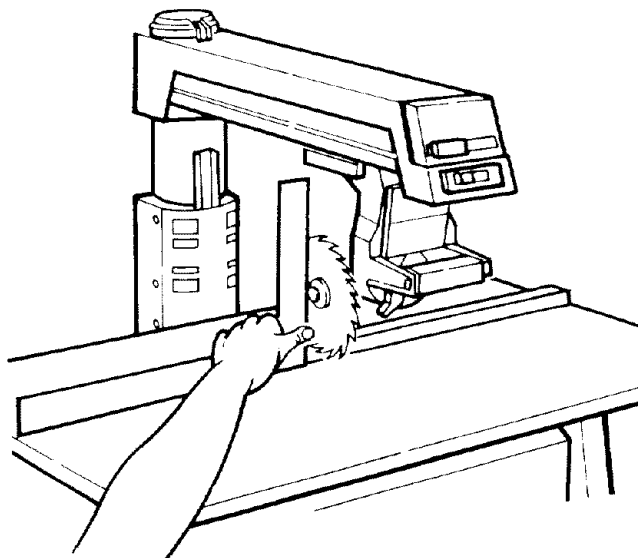

3. There should be no gap between blade and square. **Note:** *Not all blades are perfectly flat. Check different points along blade surface by making quarter turns and looking for gap each time. Consider overall fit of blade.* If there is no gap, no adjustment is needed.

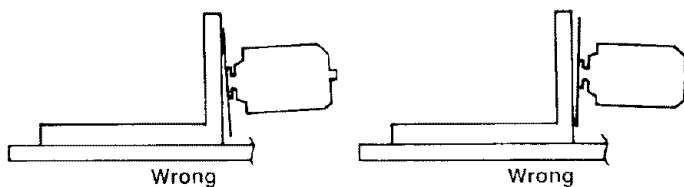
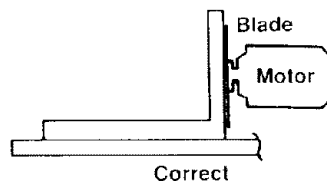

4. If there is a gap, adjust motor:
- i) unlock bevel lock
 - ii) loosen four socket head screws behind blade carriage
 - iii) move motor until blade rests flush against square
 - iv) lock bevel lock.

5. Re-check alignment and adjust as needed.

6. Tighten four socket head screws behind blade carriage.

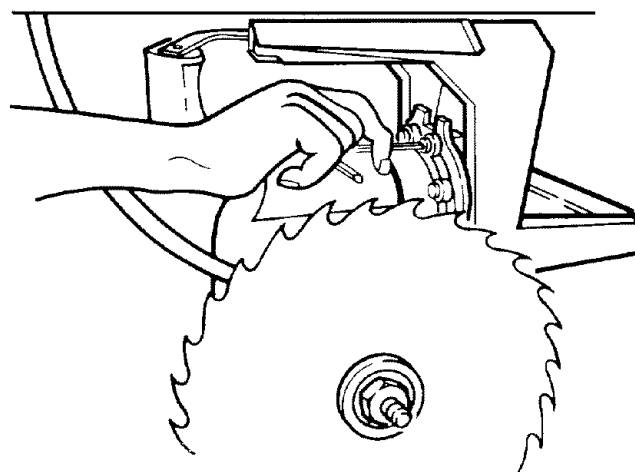

Alignment and Adjustment

Square Blade to Fence

The goal in setting the blade perpendicular to the fence is to reduce the risk of kickback when ripping. This adjustment will also reduce splintering of the workpiece and burning of the kerf during ripping and crosscutting.

1. Lower blade until it just clears table.
- 2 Place square so short edge is against fence and long edge is against flat surface of blade (not on a tooth), just above blade collar.
3. Unlock rip lock. Pull blade forward as far as you can, yet still have framing square against fence and blade. Lock rip lock.
4. There should be no gap between blade and square. **Note:** *Not all blades are perfectly flat. Check different points along blade surface by making quarter turns and looking for gap each time. Consider overall fit of blade.* If there is no gap, no adjustment is needed.

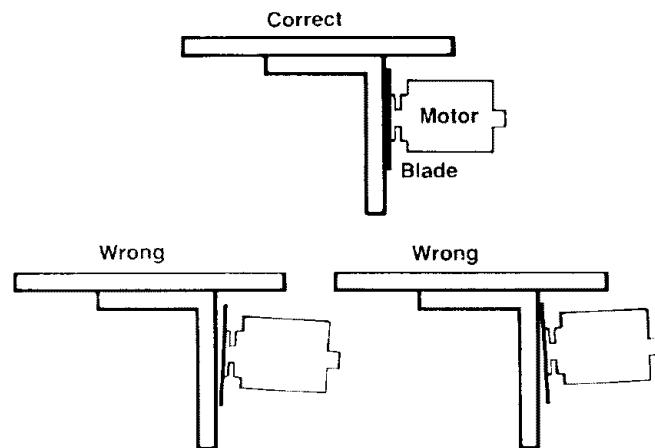
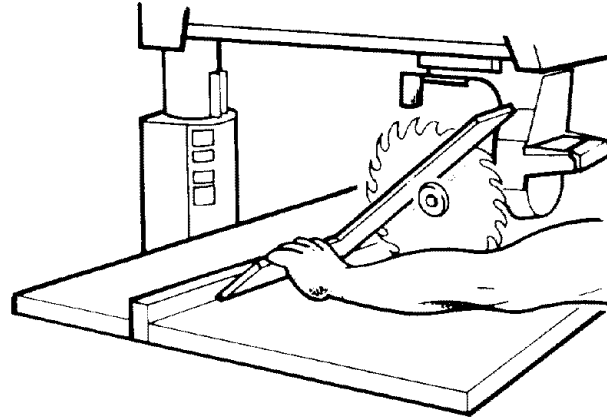

5. If there is a gap, adjust blade carriage:
 - i) unlock swivel lock
 - ii) loosen four adjusting screws under blade carriage
 - iii) grasp saw handle and move blade carriage until blade rests flush against square
 - iv) lock swivel lock.
6. Re-check alignment and adjust as needed.
7. Tighten four adjusting screws under blade carriage.

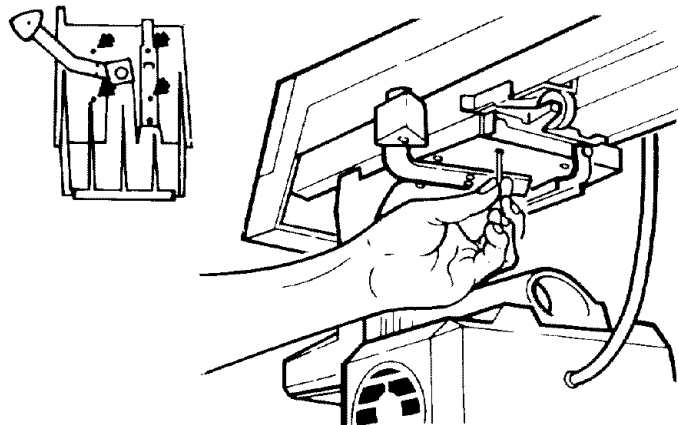

Alignment and Adjustment

Square Blade to Table for Ripping

The goal of this adjustment is to make the blade perpendicular to the table so that rip cuts will be accurate; otherwise all rip cuts will have a slight bevel angle.

1. Lock blade in out-rip position (blade towards table front, motor towards column). Lock rip lock.
2. Raise radial arm to allow clearance for square.
3. Place square so long edge is on table and short edge is against blade (not on a tooth), beside blade collar.

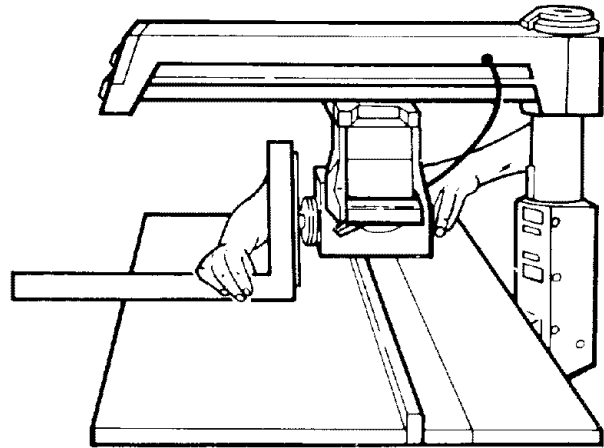

4. There should be no gap between blade and square. **Note:** *Not all blades are perfectly flat. Check different points along blade surface by making quarter turns and looking for gap each time. Consider overall fit of blade.* If there is no gap, no adjustment is needed.

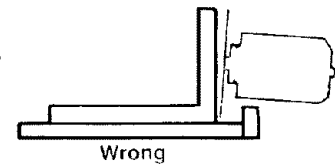
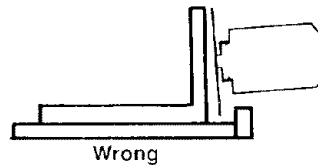
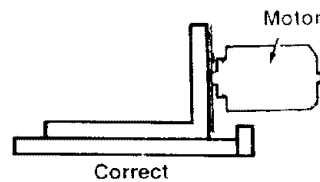

5. If there is a gap, adjust rear carriage bearing (which is visible when you go to rear of saw and look up under radial arm--carriage bearing rides on central track):

- i) hold bolt in place and loosen nut on bearing
- ii) rotate bolt until gap closes
- iii) hold bolt in place and tighten nut.

6. Re-check alignment and adjust as needed.

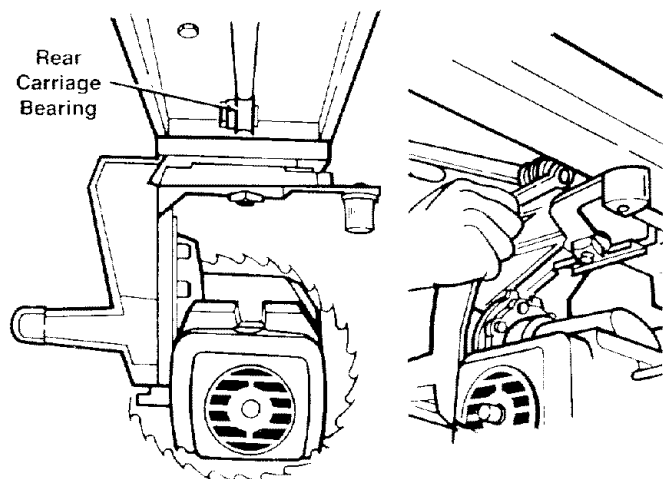

Alignment and Adjustment

Adjust Carriage Bearings

The goal of this adjustment is to eliminate looseness between the carriage bearings and the radial arm. The blade carriage should roll freely along the entire length of the radial arm, but with some resistance.

1. With blade still locked in out-rip position, unlock rip lock and move blade carriage to rear as far as it will go.
2. From front of saw, look up under radial arm to identify front carriage bearing. With thumb and index finger, get pinch-hold inside groove of bearing. Apply force to bearing and at same time, pull blade carriage forward. Force should **not** stop bearing from turning while carriage is moving.
3. If you can stop bearing from turning while carriage is moving, adjust bearings:
 - i) position blade carriage for good access to front and rear bearings
 - ii) lock rip lock
 - iii) hold front bearing bolt in place and loosen nut
 - iv) rotate bolt a few degrees, then tighten nut.

Note: Carriage bearings have eccentric bolts. High side of each bolt is marked by an arrow. Adjust rear carriage bearing same amount, but in opposite direction, as you adjust front carriage bearing.

Note: Do not overtighten. Overtightening can cause blade carriage to move with difficulty and will reduce life of track and bearings.

4. Before proceeding to next section, repeat steps to Square Blade to Table for Ripping, because adjusting carriage bearings affects that alignment.

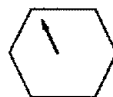
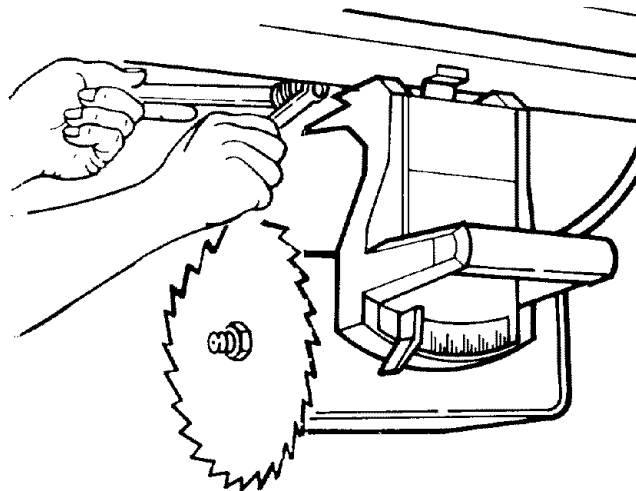
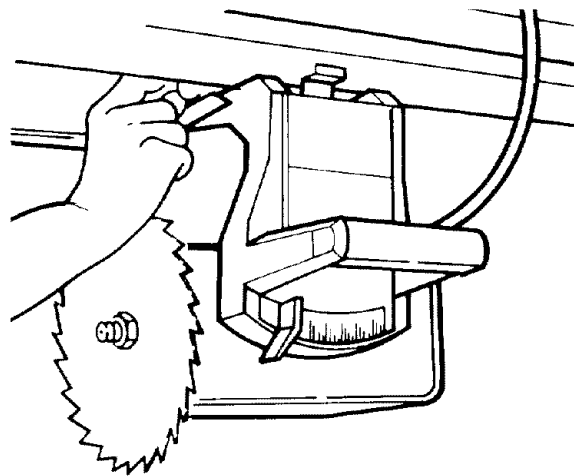

OK
Both Arrows Point Up

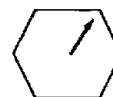

OK
Both Arrows Point Down

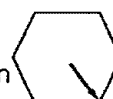

WRONG
One Arrow Points Up
One Arrow Points Down



Alignment and Adjustment

Make Blade Parallel to Table

The goal of this adjustment is to keep the workpiece from being thrown or damaged. This adjustment will also reduce splintering of the workpiece and burning of the kerf during ripping and crosscutting.

1. Lock blade in straight crosscut position.
2. Pull blade forward and lock rip lock.
3. Raise blade at least 2" above table.
4. Lock motor at 90° bevel (blade horizontal).
5. Place square so long side is on table under right side of blade, and short side hangs down vertically at front of saw. Push edge of square against fence.
6. Lower radial arm until blade surface, not a tooth, just rests on square.

7. There should be no gap between blade and square. **Note:** *Not all blades are perfectly flat. Check different points along blade surface by making quarter turns and looking for gap each time. Consider overall fit of blade.* If there is no gap, no adjustment is needed.

8. If there is a gap, adjust motor support:
 - i) unlock bevel lock
 - ii) loosen two screws on back of motor support
 - iii) move motor support until blade rests flush against square
 - iv) lock bevel lock.

9. Re-check alignment and adjust as needed.

10. Tighten motor support screws.

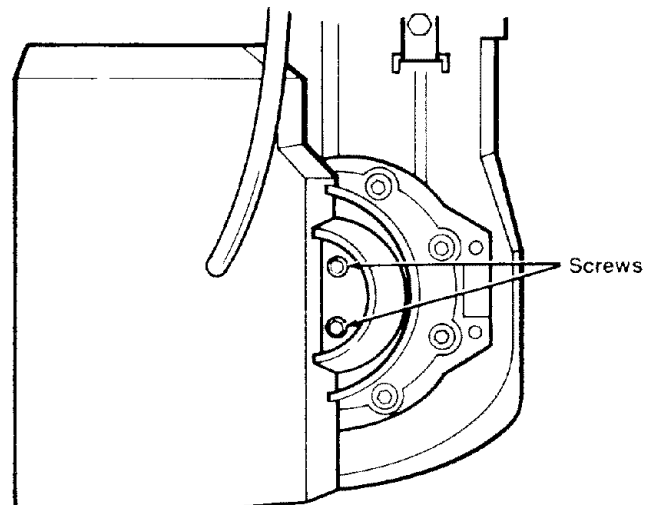
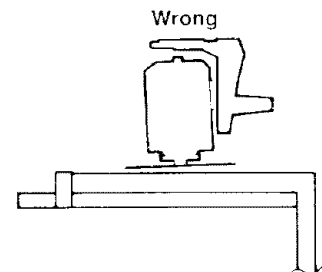
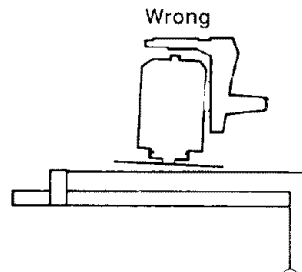
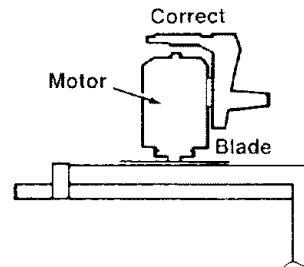
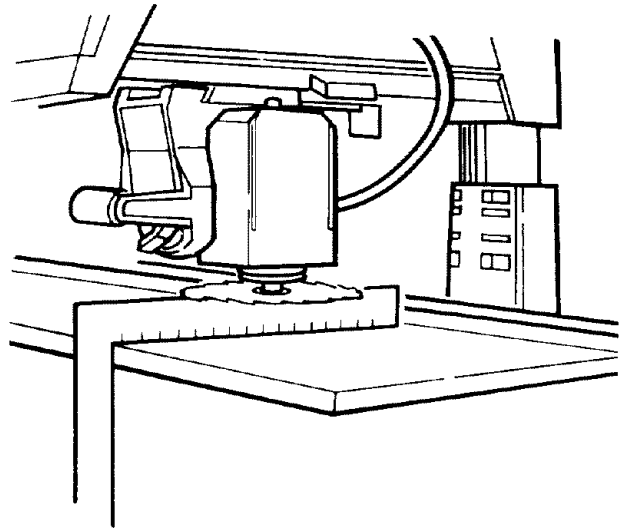

Alignment and Adjustment

Blade alignment and adjustment are complete. *Note: It is important that you periodically check alignment and adjustment to insure accurate cuts and improve the safety of cutting procedures. Be aware that alignment in one plane necessarily affects alignment in other planes. Thus, the blade may be perfectly aligned for one type of cut but not another.*

Install Guard

The guard is a very important safety feature. It covers a large part of the blade and helps protect against severe cuts. Always use the guard and adjust it according to instructions for the type of cut.

1. Raise blade at least 5" from table.
2. Lock motor at 0° bevel (blade vertical).
3. Loosen guard clamp screw until it no longer touches metal plate.

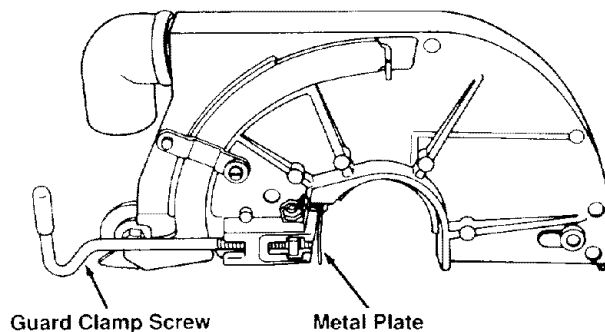

4. Place guard over blade so guard clamp screw is towards table front. Guard will fall into place when ridge on inside of guard slides into slot on motor.
5. Adjust guard to make sure bottom edge is parallel to table. Tighten guard clamp screw.

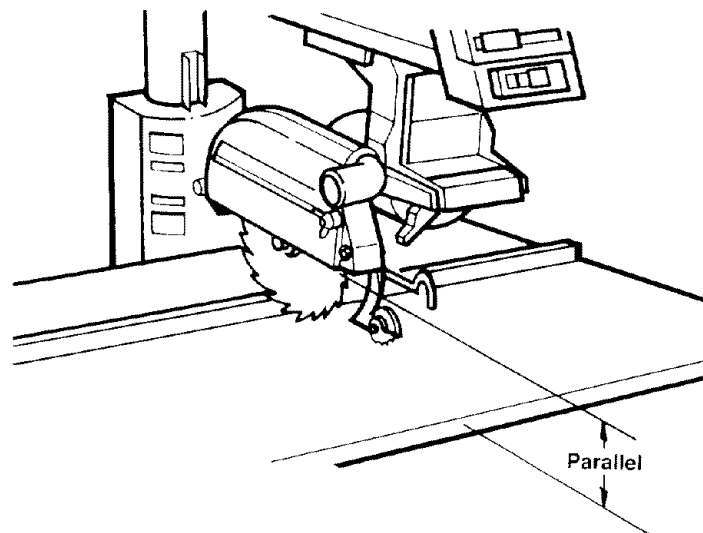

Align Spreader to Blade

The goal of this adjustment is to make the spreader directly in line with the blade. Spreader alignment is an important safety factor. The spreader rides in the kerf of the cut workpiece during ripping to help keep the two sides of the workpiece from pinching on the blade. Blade pinching is a cause of kickback.

Alignment and Adjustment

1. Lock blade in in-rip position (blade towards column, motor towards table front).
2. Lower blade until it just clears table.
3. Unlock rip lock, move blade back until it touches fence, and lock rip lock.
4. Loosen pawls/spreader wing nut and lower pawls/spreader to fence. Spreader should rest flat against fence, and one set of pawls should rest on top of fence.
5. If adjustment is needed:
 - i) loosen both spreader nuts
 - ii) slide spreader against fence and rest pawls on fence
 - iii) tighten spreader nuts.
6. Raise pawls/spreader unit up to guard and tighten wing nut.

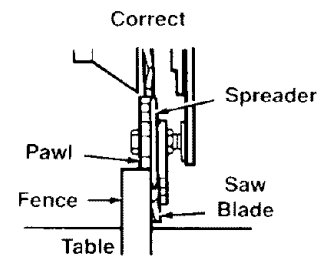

Complete Adjustments

Go to Digital Display Section and follow instructions to install battery, align encoders, and set zero reference points.

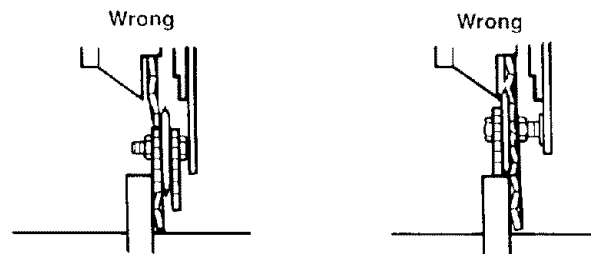

Digital Display

The digital display runs on battery power. It tells the position of the blade and radial arm at the touch of a button. The display automatically turns itself off approximately three minutes after a change in blade or arm position has been made. The system continues to track the position of the blade and arm even when the display is turned off.

Button Functions

- ON/OFF** Turns display on and off.
- REF SET** Used to set "zero" reference points.
- BEVEL** Displays bevel angle. Display is positive when motor has been moved counterclockwise from zero reference point; negative when motor has been moved clockwise from zero reference point.

Error Messages

The zero reference points you set according to the instructions later in this section will be stored in memory at all times, whether the display is on or off. If an error occurs, you will see either of these messages displayed.

An error can be caused by sudden movement of the radial arm or blade carriage when the electronic display is off. When this happens, reset the zero reference point for the function showing the error.

When the display is faded or hard to read, replace the battery and reset all the zero reference points.

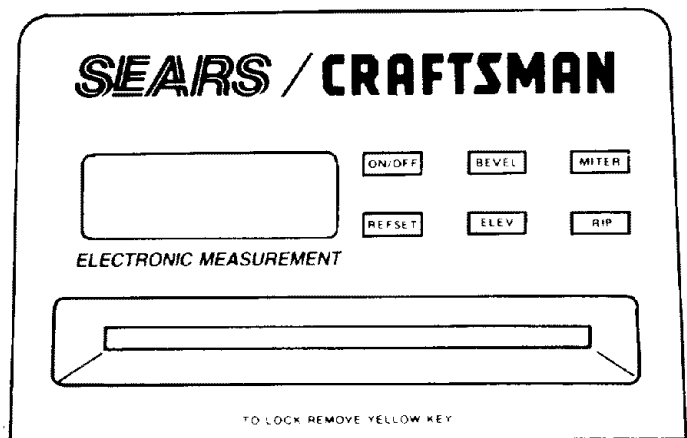

- ELEV** Displays distance between table and blade. Display is positive when blade is above zero reference point; negative when blade is below zero reference point.
- MITER** Displays miter angle. Display is positive when blade is to right of zero reference point; negative when blade is to left of zero reference point.
- RIP** Displays distance between blade and fence in in-rip or out-rip positions.

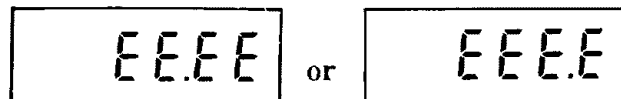

Install Battery

1. Set out
 - battery
 - battery cover.
2. Position battery with angled corner on top right and slide battery all the way into opening behind digital display, pushing slightly downward until it snaps into place.

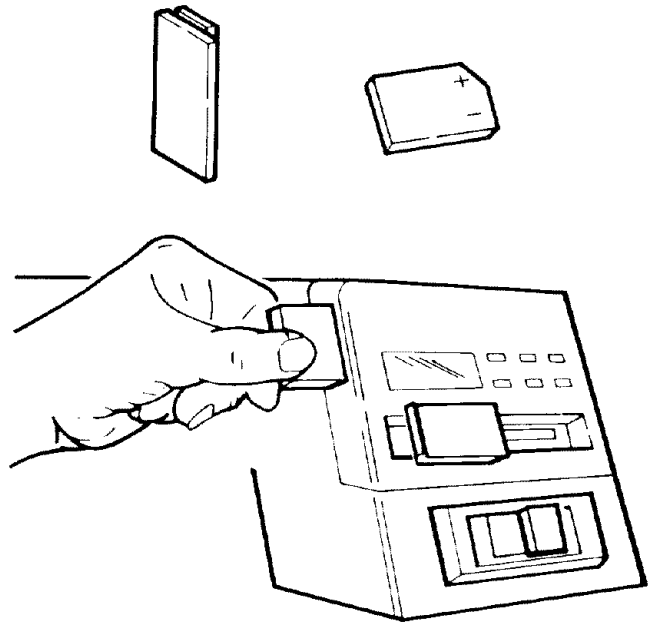

3. Look at display. It should look like this:
If it shows nothing, push in and slightly upwards on battery to remove it, then re-install.
If there still is no display, remove battery, wipe off contacts, then re-install.
If there is still no display, try a new 6V alkaline battery or contact Sears.
4. When display shows correctly, snap battery cover into place.
5. Follow steps to align encoders and set zero reference points.





To Replace Battery

1. Use screwdriver to pry off battery cover.
2. Push in and slightly upwards on battery to remove it. Install new 6V alkaline battery.
3. Follow steps to set zero reference points.

Digital Display

Align Encoders

Miter Encoder

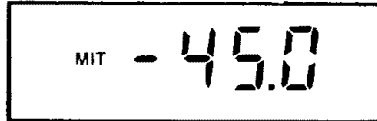
1. Turn display on.
2. Lock radial arm at 0° miter.
3. Push MITER button.
4. Push REF SET button. Display will read:

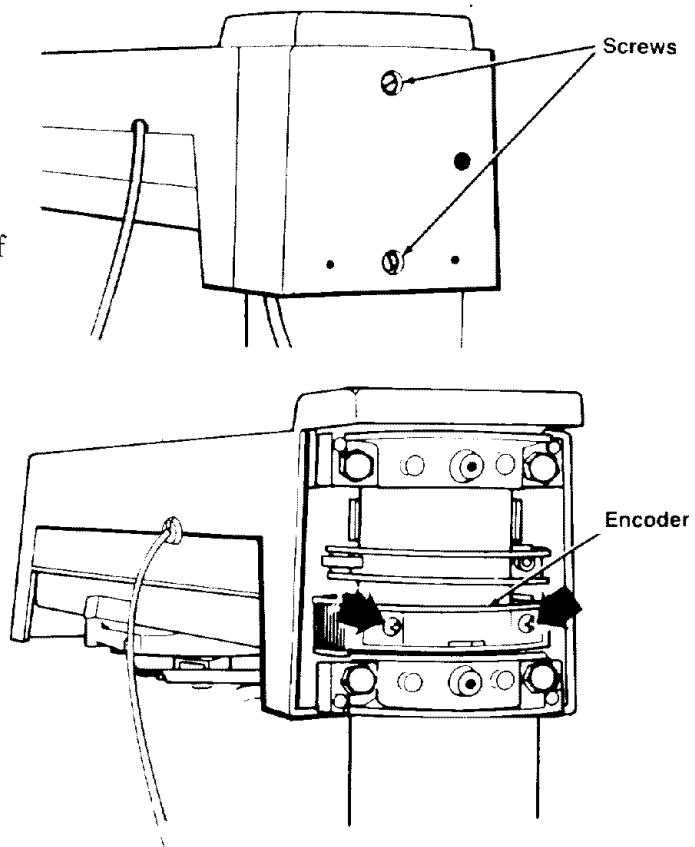
5. Unlock miter lock, move radial arm to right until it snaps into pre-set indexed position and lock miter lock. Display should read:

6. Unlock miter lock, move radial arm to left until it snaps into pre-set indexed position, and lock miter lock. Display should read:

7. If display reads as it should, miter encoder is aligned correctly---no adjustment is needed.
8. If display does not read as it should:
 - i) unscrew two screws from back cover of radial arm, and remove cover
 - ii) unlock miter lock, move arm to right until it snaps into pre-set indexed position, and lock miter lock
 - iii) loosen miter encoder mounting screws inside rear of radial arm to allow encoder to slide side to side
 - iv) slide or slightly tap encoder until display reads 45°
 - v) tighten miter encoder mounting screws.
9. Repeat steps to align miter encoder. When display reads as it should, re-install back cover.

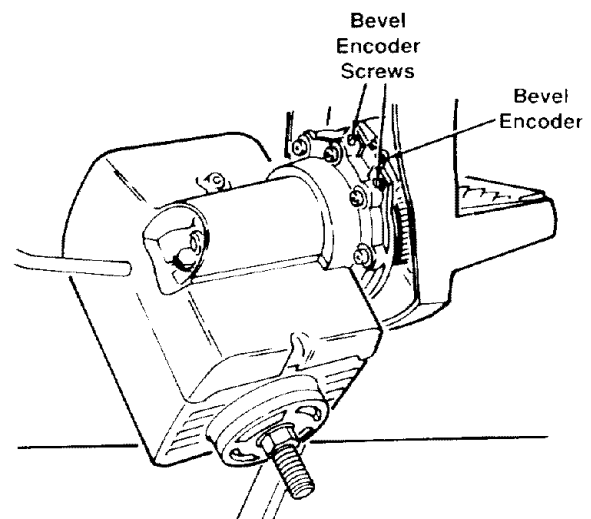
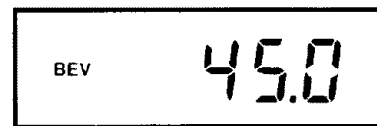

Digital Display

Bevel Encoder

1. Turn display on.
2. Lock radial arm at 0° miter. Lock motor at 0° bevel.
3. Push BEVEL button.
4. Push REF SET button. Display will read:
 5. Support motor, unlock bevel lock, move motor counterclockwise until it snaps into pre-set indexed position and lock bevel lock. Display should read:
 6. Support motor, unlock bevel lock, move motor counterclockwise until it snaps into next pre-set indexed position (blade horizontal) and lock bevel lock. Display should read:
 7. If display reads as it should, bevel encoder is aligned correctly--no adjustment is needed.
 8. If display does not read as it should:
 - i) unlock bevel lock, move motor clockwise until it snaps into pre-set indexed position, and lock bevel lock
 - ii) loosen bevel encoder screws on backside of blade carriage to allow encoder to slide side to side
 - iii) slide or slightly tap encoder until display reads 45°
 - iv) tighten bevel encoder screws.
 9. Repeat steps to align bevel encoder.



Set Zero Reference Points For Bevel, Miter, and Elevation

1. Set blade in straight crosscut position (0° miter) (0° bevel). Lower blade until it just touches table. **Note:** *This is the usual blade position for setting these zero reference points.*

Digital Display

2. Turn display on.

3. Push MITER button, then push REF SET button. Display will read:



4. Push BEVEL button, then push REF SET button. Display will read:



5. Push ELEV button, then push REF SET button. Display will read:



Set Zero Reference Point For In-Rip

1. Put fence in front position and lock table locks.

2. Lock blade in in-rip position (blade towards column, motor towards table front).

3. Unlock rip lock, push blade against fence, and lock rip lock.

4. Push RIP button, then push REF SET button. Display should read:

If it reads O-RIP instead of RIP, push RIP button then push REF SET button.

If display reads 10.00 instead of .00, push REF SET button.

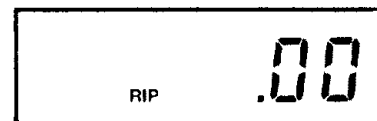

Set Zero Reference Point For Out-Rip

1. Unlock rip lock and pull blade away from fence.

2. Unlock table locks, move fence to rear position, and lock table locks.

3. Lock blade in out-rip position (motor towards column, blade towards table front).

Digital Display

4. Position blade 10" from fence, as measured to nearest tooth, and lock rip lock.

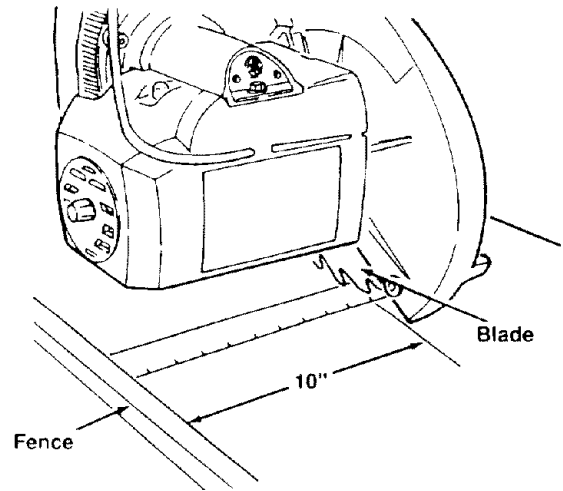

5. Push RIP button, then push REF SET button. Display should read:
If it reads RIP instead of O-RIP, push RIP button, then push REF SET button.
If it reads .00 instead of 10.00, push REF SET button.



Conversion Table

Decimal equivalents of fractions, rounded to nearest hundredth inch:

$\frac{1}{32}$.03	$\frac{17}{32}$.53
$\frac{1}{16}$.06	$\frac{9}{16}$.56
$\frac{3}{32}$.09	$\frac{19}{32}$.60
$\frac{1}{8}$.12	$\frac{5}{8}$.63
$\frac{5}{32}$.16	$\frac{21}{32}$.66
$\frac{3}{16}$.19	$\frac{11}{16}$.69
$\frac{7}{32}$.22	$\frac{23}{32}$.72
$\frac{1}{4}$.25	$\frac{3}{4}$.75
$\frac{9}{32}$.28	$\frac{25}{32}$.78
$\frac{5}{16}$.31	$\frac{13}{16}$.81
$\frac{11}{32}$.34	$\frac{27}{32}$.85
$\frac{3}{8}$.38	$\frac{7}{8}$.88
$\frac{13}{32}$.41	$\frac{29}{32}$.91
$\frac{7}{16}$.44	$\frac{15}{16}$.94
$\frac{15}{32}$.47	$\frac{31}{32}$.97
$\frac{1}{2}$.50	1	1.00

Electrical Connections

Motor Specifications

The AC motor used in the saw is a capacitor-start, non-reversible type. The models covered in this manual have the following specifications:

Rated H.P.	1.5
Max Developed H.P.	2.75
Voltage	120/240
Amperes	12/6
Hertz (cycles)	60
Phase	Single
RPM	3450
Arbor Shaft Rotation	Clockwise

Note: If saw does not start when switched on, immediately turn saw off and refer to Troubleshooting. Leaving the switch on will destroy the motor.

Power Supply

⚠ WARNING

Saw is factory wired for 120V operation. Connect to 120V, 15-AMP branch circuit and use 15-AMP time delay fuse or circuit breaker.

Failure to connect in this way could result in injury from shock or fire.

The saw must be properly grounded. Not all outlets are properly grounded. If you are not sure that your outlet is properly grounded, have it checked by a qualified electrician.

⚠ WARNING

If not properly grounded, this power tool could cause electrical shock, particularly when used in damp locations.

⚠ WARNING

If electrical shock occurs, your reaction to shock could bring hands into contact with blade.

⚠ WARNING

To avoid electric shock or fire, immediately replace worn, cut, or damaged power cord.

The unit is wired for 120V and has a plug that looks like this:

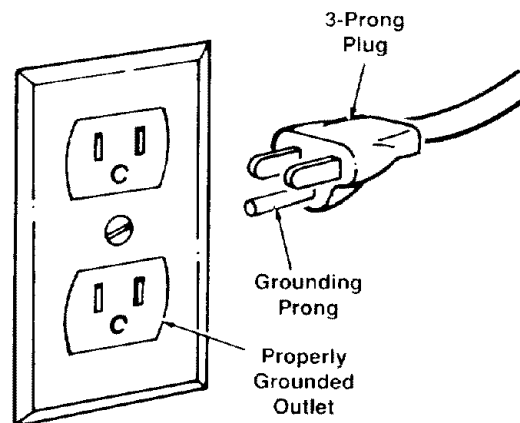

The power tool is equipped with a 3-conductor cord and grounding type plug listed by Underwriters' Laboratories. The ground conductor has a green jacket and is attached to the tool housing at one end and to the ground prong in the attachment plug at the other end.

The plug requires a mating 3-conductor grounded type outlet as shown above. If you have an outlet that is of the 2-prong type, it is recommended that you have a qualified electrician replace it with a properly grounded 3-prong outlet.

Electrical Connections

⚠ WARNING

To maintain proper tool grounding, whenever outlet you are planning to use for this power tool is of 2-prong type do not remove or alter grounding prong in any manner.

An adapter is available for connecting the plug to 2-prong receptables. The green grounding lead extending from the adapter must be connected to a permanent ground such as to a properly grounded outlet box.

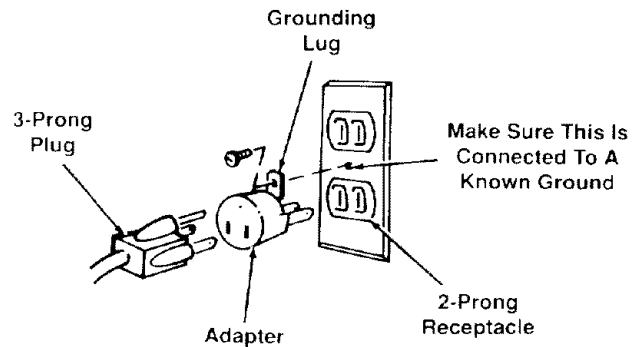

⚠ WARNING

Adapter illustrated is for use only if you already have a properly grounded 2-prong receptacle.

Extension Cords

The use of any extension cord will cause some loss of power. Determine the minimum wire size (American Wire Gage No. (AWG#)) extension cord. Use only 3-wire extension cords with 3-prong grounding type plug and 3-pole receptacles which accept the tool's plug.

Wire Sizes Required (AWG #)

Cord Length	120V	240V
0-25 ft	No. 14	No. 16
26-50 ft	No. 12	No. 14
51-100 ft	No. 10	No. 12

Note: The smaller the gauge number, the heavier the cord. For circuits farther away from the electrical circuit box, wire size must be increased proportionately to deliver ample voltage to the motor.

Motor Protection & Reset Button

The motor protector opens the power line circuit and stops the motor when the motor temperature exceeds a safe level, the motor is overloaded, or a low voltage condition exists.

When the protector activates, immediately turn saw off, remove yellow key and wait for motor to cool. Push red re-set button and listen/feel for click to indicate protector is re-set. If you do not hear/feel a click, motor is still too hot. Wait a while longer and repeat.

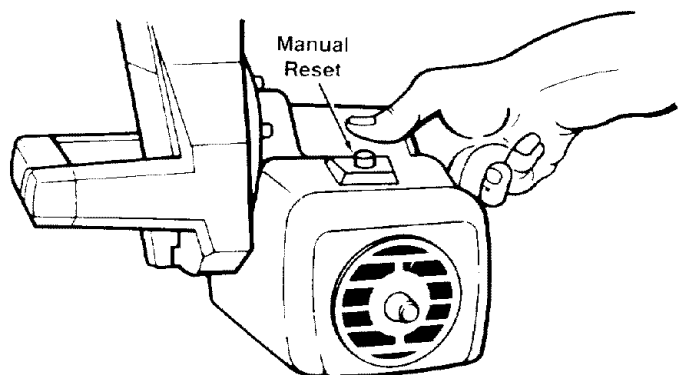

Electrical Connections

To Change Motor Voltage to 240 A.C.

Under normal home workshop conditions, if full voltage is supplied to the motor, the saw will operate efficiently on 120V. If any of the following conditions exist, it will be advisable to have a qualified electrician reconnect the motor for 240V operation:

- heavy duty operation
- either undersized or overloaded branch circuit serves the saw
- power company cannot correct a low voltage situation.

The following procedure to change motor voltage should be followed only by a qualified electrician. **Note:** *Whenever changing the switch position from 120 to 240V, make certain that all necessary steps (including proper fusing of the branch circuit) are completed.*

1. Unplug saw.
2. Remove pan head screw from top of motor cover. Remove motor cover panel at blade end of motor.
3. Use small screwdriver to slide dual voltage switch to 240V position.
4. Re-install motor cover panel.
5. Replace 120V power cord plug with 240V, 15 amp, 3-prong plug.
6. Connect power cord white and black leads to two "hot" plug blades; connect power cord grounding wire to plug ground prong.
7. Plug cord into 240V, 15 amp, 3-blade receptacle. Make sure receptacle is connected to a 240V A.C. power supply through a 240V branch circuit having at least a 15 amp time delay fuse or circuit breaker. **Note:** *No adapter is available for this type plug.*

DANGER

To avoid electric shock, unplug saw before changing motor voltage.

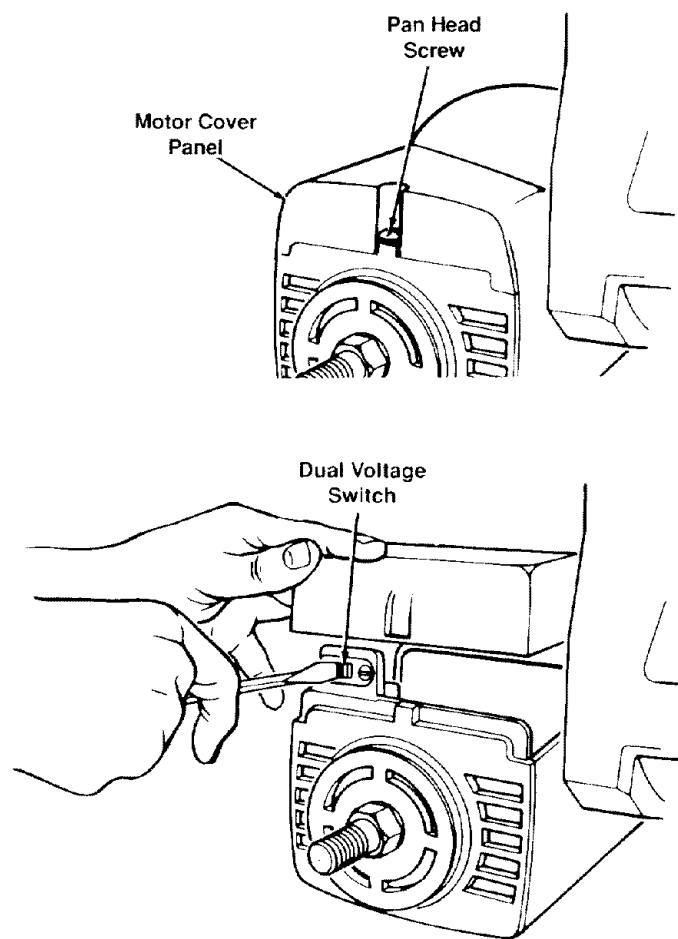

Crosscutting Defined

Crosscutting is cutting a workpiece to length. The workpiece is held firmly against the fence, and the blade is pulled through the workpiece to make the cut. Straight, bevel, miter and compound cuts can be made.

Crosscutting Safety

The hazards associated with crosscutting include: exposed blade teeth, rolling carriage, and thrown workpiece. This section explains these hazards and tells how to avoid them or reduce the risk of their happening. **Read this section before making any type of crosscut. Follow these steps every time you make a crosscut.**

Exposed Blade Teeth

WARNING

During crosscutting, blade teeth can be exposed. To reduce risk of having fingers, hand or arm cut off:

- ✓ Set bottom edge of guard parallel to table to cover upper half of blade.
- ✓ Lower pawls to clear fence or workpiece, whichever is higher, by $\frac{1}{4}$ ". Lowered pawls act as partial barrier to front of blade.
- ✓ Keep hands away from blade and out of blade path. Keep hand holding down workpiece at least 8" from blade.
- ✓ Blade can come off table edge beyond 30° left miter position. Use right miter position whenever possible.
- ✓ Do not cut freehand. You will not be able to control workpiece.
- ✓ If blade jams, turn off saw, remove yellow key, then free blade.

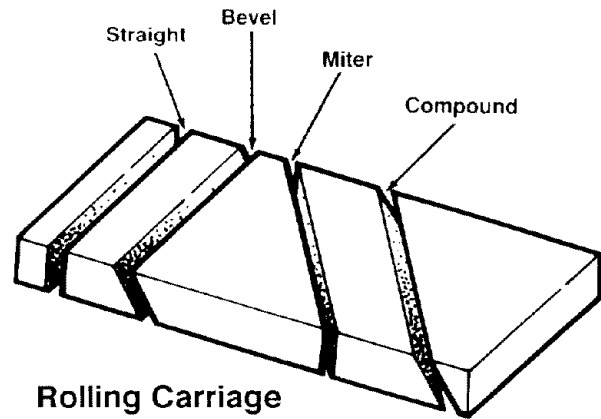

Rolling Carriage

WARNING

When saw is turned on, blade can suddenly come forward. To reduce risk of this happening:

- ✓ Keep one hand on saw handle when turning saw on.
- ✓ Adjust leveling feet to make sure radial arm slants slightly toward rear.

Thrown Workpiece

CAUTION

Workpiece could be picked up by spinning blade and thrown. You might be hit by thrown workpiece. To reduce risk of thrown workpiece:

- ✓ Make sure installed fence is at least half as high as the workpiece, and never less than $\frac{3}{4}$ ".
- ✓ Start and finish cut with blade in rear-most position, behind fence.
- ✓ Firmly hold workpiece flat on table and up against fence. Cut only one workpiece at a time.
- ✓ Pull blade through workpiece only distance needed to complete cut, and never more than half diameter of blade.
- ✓ Do not touch or move workpieces until blade has stopped spinning.
- ✓ Use length stop only on end of workpiece which is held down.
- ✓ Use table extensions to support workpieces that extend beyond table.

Crosscutting

Crosscut Kerfs

A kerf or shallow cut is needed in the table and fence to serve as a path for the blade and to ensure that the blade cuts all the way through the workpiece. **A kerf is needed for each different cutting path.**

To make an approximately $\frac{1}{16}$ " deep kerf:

1. Prepare table:
 - put fence in front position
 - lock table locks.
2. Prepare blade:
 - lock blade in crosscut position
 - lock radial arm at desired miter angle
 - lock motor at desired bevel angle
 - unlock rip lock and push blade to rearmost position, behind fence
 - lower blade to just clear table
 - lower pawls to clear fence by $\frac{1}{4}$ ".
3. Grasp saw handle, then turn saw on. **Keep one hand on saw handle through step 6.**
4. Slowly lower blade until it touches table, then lower by another turn of hand-wheel.

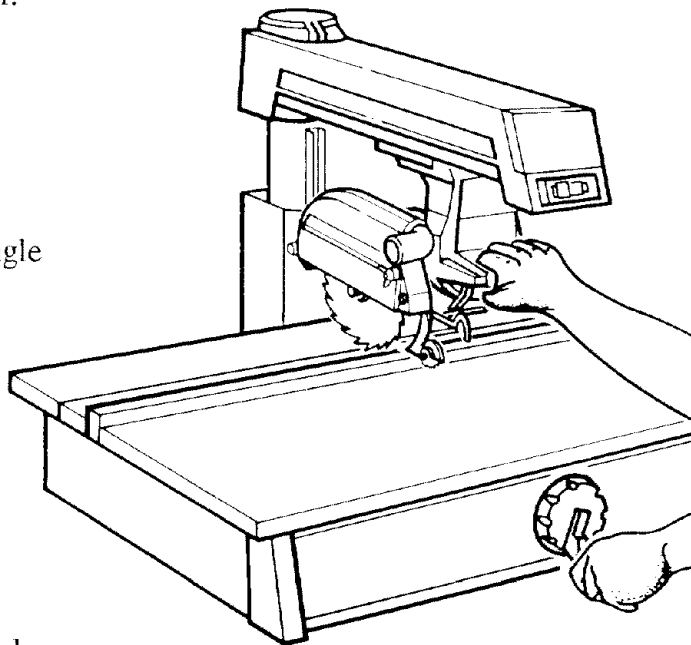

5. Pull blade through fence and across table as far as it will go.
6. Push blade to rearmost position, behind fence, and turn saw off. Keep hand on saw handle until blade stops spinning.

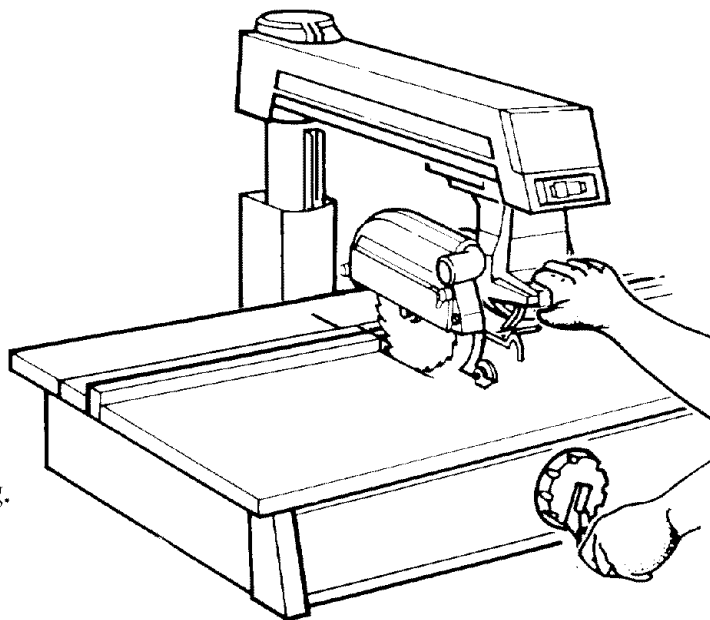

Crosscutting

Making Crosscuts

Follow these steps to make crosscuts.

1. Prepare table:

- put fence in front position
- lock table locks.

2. Prepare blade:

- lock blade in crosscut position
- lock radial arm at desired miter angle
- lock motor at desired bevel angle
- unlock rip lock and push blade to rearmost position, behind fence
- lower blade into kerf but not touching kerf bottom (blade should move freely).

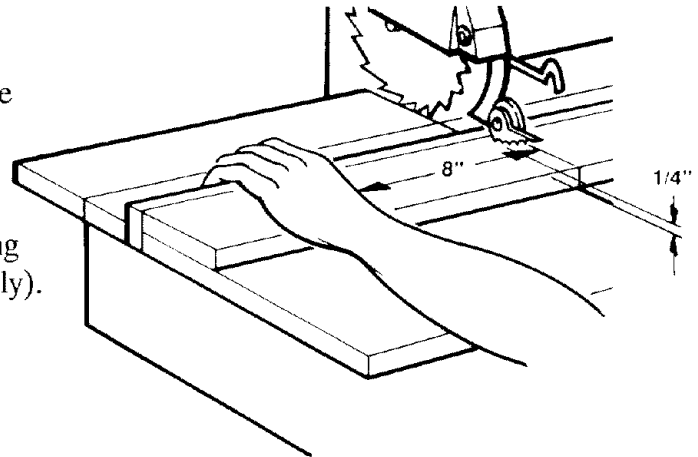

3. Position workpiece against fence, and lower pawls to clear fence or workpiece, whichever is higher, by 1/4".

4. Grasp saw handle, then turn saw on. **Keep one hand on saw handle through step 7.**

5. Hold workpiece down and against fence. Keep hand at least 8" away from blade.

6. Pull blade through fence and workpiece **only far enough to complete cut, and never more than half diameter of blade.**

7. Push blade carriage to rearmost position, behind fence, and turn saw off. Keep hand on saw handle until blade stops spinning.

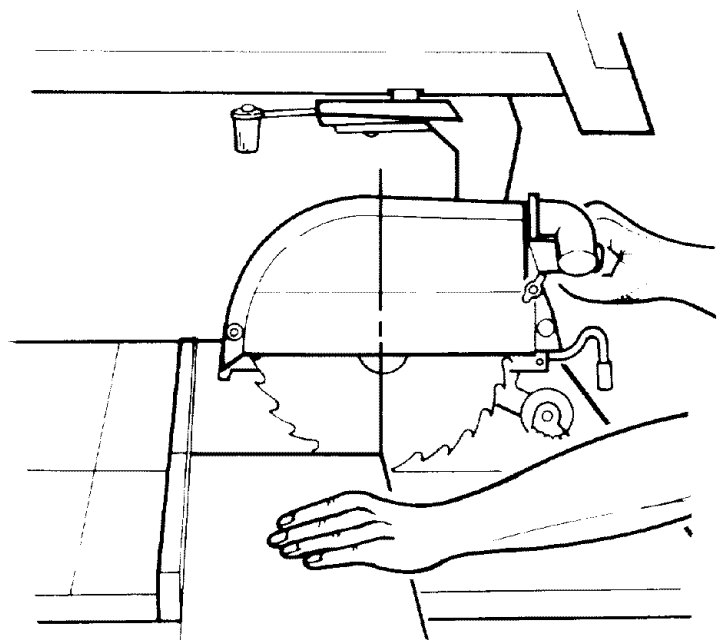

Crosscutting

Repetitive Crosscutting

Repetitive crosscutting is the repeated and continuous cutting of many pieces of lumber to the same length. Carriage and length stops can help make this type of crosscutting more efficient. A lower blade guard offers protection against the side of the blade (See Accessories).

A carriage stop defines the distance needed to pull the blade through to complete each cut. This will prevent pulling the blade through more than the recommended distance.

To make a carriage stop use 1x2 lumber:

- i) cut two pieces, each 2" long
- ii) clamp a piece on each side of radial arm, so blade carriage stops at distance needed to complete cut
- iii) check that clamps do not interfere with hand grip on saw handle.

A length stop defines the cut length and ensures that all pieces will be cut to the same size. Clamp a piece of 1x2 lumber on the fence to define the cut length. Use **a length stop only on the end of the workpiece which is held down.**

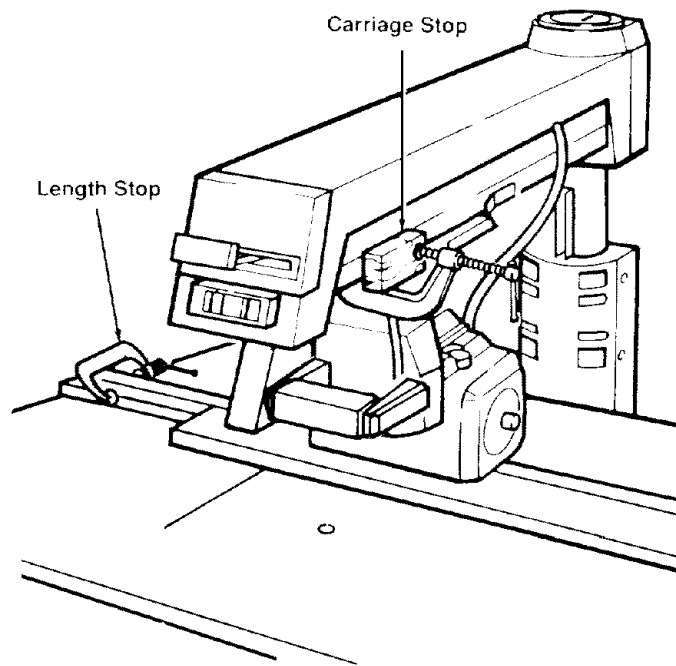

Crosscutting Hints

1. To extend life of table top, buy auxiliary table cover (see Accessories) or make one out of 1/4" plywood or fiber-board. Clamp or nail to original table top, section by section. If you use nails, nail in the four corners to make sure blade will not contact nails.
2. Make several fences, so each will have only a few kerfs (See Cutting Aides). Too many kerfs in a fence weaken it.
3. When making miter or bevel cuts, use extra force to hold workpiece down be-

cause it tends to move during these types of cuts.

4. When cutting hard woods, like oak, or making compound cuts, keep arm holding saw handle rigid and pull blade through slowly.
5. Keep table clean of chips and sawdust.
6. Use the right blade for each job.
7. Use sharp blades.
8. To keep cut line accurate, periodically check blade alignment.
9. Do not cut severely warped or crooked workpieces.

Ripping Defined

Ripping is changing the width of a workpiece by cutting along its length. The workpiece is fed into the blade, which rotates in a fixed position, parallel to the fence, a set distance from the fence. A solid fence (no kerfs) serves as a guide for the workpiece. Place the fence in the front position for narrower workpieces, and in the rear for wider ones.

In-Rip and Out-Rip Positions

In-rip and out-rip refer to blade position.

In-rip: the blade is toward the column, and the motor is toward the table front. In-rip is recommended because this position allows better visibility of the workpiece and your hands. Use in-rip when you set the blade $\frac{1}{2}$ to 16" from the fence.

Out-rip: the blade is toward the table front, and the motor is toward the column. Use out-rip **only** when you set the blade 12" or more from the fence.

Infeed and Outfeed Directions

Infeed and outfeed refer to sides of the blade.

Infeed: the side of the blade where the guard nose is. **Always start a rip cut at the infeed side and push the workpiece through to the outfeed side.**

Outfeed: the side of the blade where the pawls and spreader are. **Never start a rip cut at the outfeed side. This is wrong way feed. Never put hands on the outfeed side of the blade when ripping because they can be pulled back into the spinning blade.**

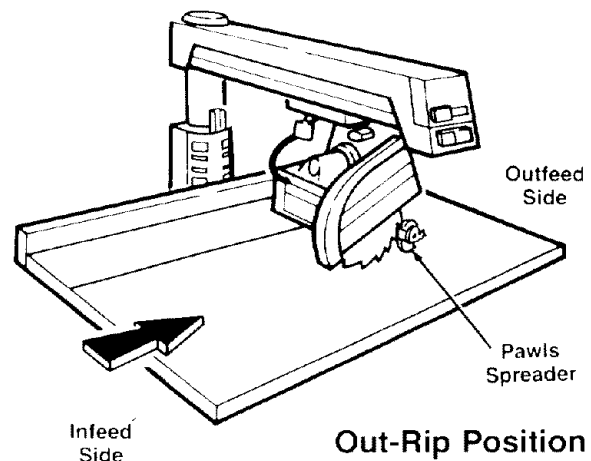
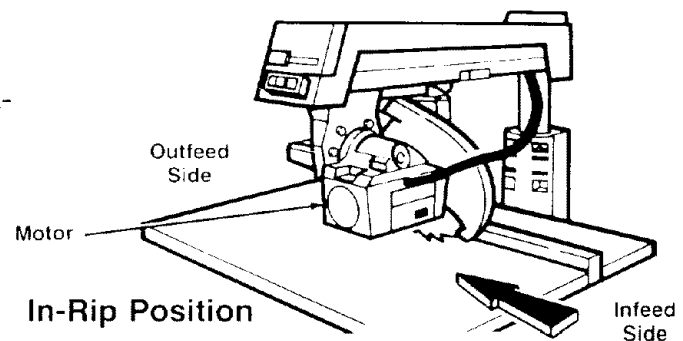
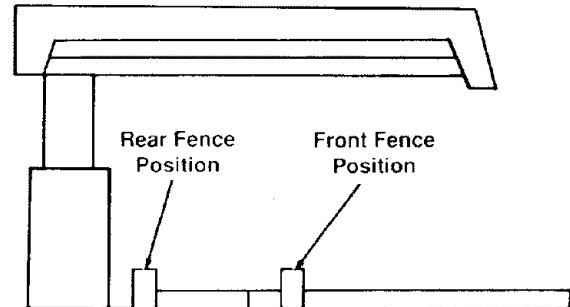

Ripping

Workpiece Positioning

Always set up so that the widest part of the workpiece is between the blade and fence. This gives you greater clearance for push sticks, and allows better stability for feeding the workpiece.

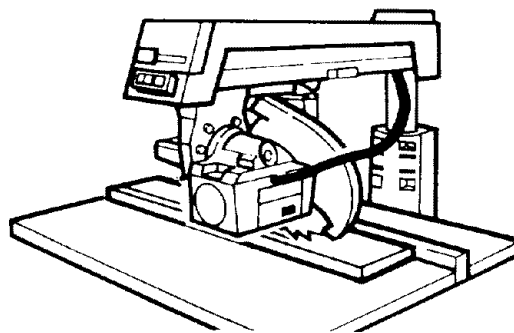

Example: to rip 1" off a 10" wide workpiece, set blade in in-rip position, 9" from fence.

Push Sticks and Push Blocks

Use push sticks and push blocks instead of the hands to push the workpiece through to complete cuts. They help keep hands away from the blade. A push block is used with an auxiliary fence (see Cutting Aides).

Use a push block and auxiliary fence when the blade is set $\frac{1}{2}$ to 2" from the fence.

Use a push stick when the blade is set 2" or more from the fence.

Do not set the blade closer than $\frac{1}{2}$ " to the fence. The radial saw is the wrong tool for such a narrow a cut. A band saw would be more appropriate for this type of cut.

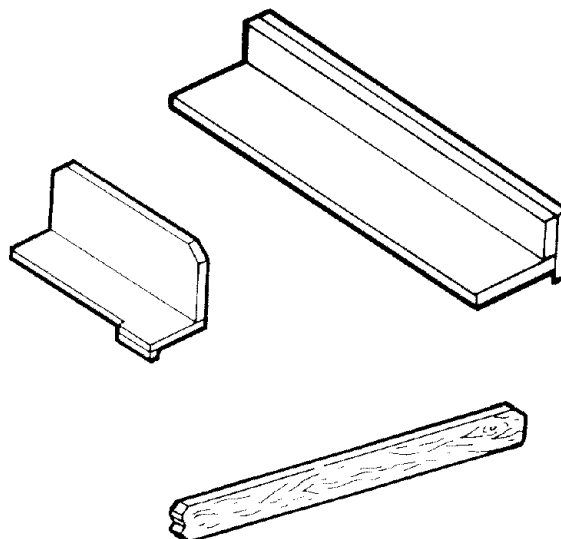

Ripping Safety

The hazards associated with ripping include: outfeed zone hazard, kickback, and wrong way feed. This section explains these hazards and tells how to avoid them or reduce the risk of their happening.

Read this section before making any type of rip cut. Follow these steps every time you make a rip cut.

Outfeed Zone Hazard

DANGER

Rotational force of blade can pull hands and fingers back into blade. Touching, holding, or pulling on outfeed side of workpiece while blade is still spinning will result in fingers, hand or arm being cut off.

To reduce risk of outfeed hazard:

- ✓ Set pawls and spreader; they act as partial barrier to outfeed side.
- ✓ Start and finish cut from **infeed** side.
- ✓ Keep both hands on infeed side.
- ✓ Keep hands away from outfeed side.
- ✓ Push workpiece through to complete cut. Do not reach around to pull it.
- ✓ If blade jams, turn saw off, remove yellow key, then free blade.

Kickback

Kickback is the uncontrolled propelling of the workpiece back toward the user.

WARNING

Kickback can happen when blade is pinched or bound by workpiece. Pinching or binding can happen when:

- pawls and spreader are not used or not set correctly
- spreader is not aligned with blade
- blade is not parallel to fence
- workpiece is twisted or warped and rocks on table top
- pressure is put on outfeed side of workpiece
- workpiece is released before being pushed past pawls and spreader
- user touches or tries to pull workpiece through outfeed side before blade has stopped spinning.

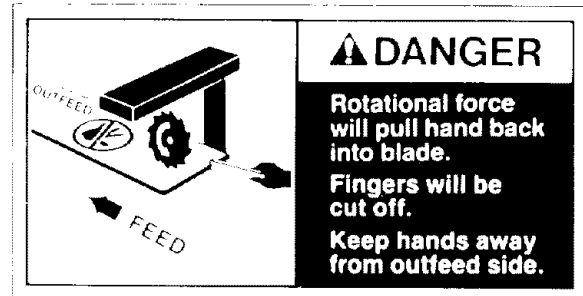

Ripping

To reduce risk of kickback:

- ✓ Set pawls and spreader according to ripping set-up procedure. Correctly set spreader is more likely to prevent workpiece from binding or pinching blade; correctly set pawls are more likely to grab into workpiece to stop or slow kickback if one happens.
- ✓ Check that spreader is in line with blade (see Alignment: Spreader to Blade).
- ✓ Cut only straight workpieces so surface will lie flat on table and edge will stay tight against fence. If you must cut an irregular workpiece, attach a straight edge (see Cutting Aides).
- ✓ Push workpiece through from infeed to outfeed side until it is completely past pawls and spreader.
- ✓ Use featherboard (see Cutting Aides).
- ✓ Keep hands away from outfeed side.
- ✓ If blade jams, turn saw off, remove yellow key, then free blade.
- ✓ When cutting composition materials, or other materials with one smooth and one rough side, put rough side up so pawls will be more likely to grab.

Wrong Way Feed

Wrong way feed is ripping by feeding the workpiece into the outfeed side of the blade.

WARNING

Rotational force of blade will pull workpiece through violently if workpiece is fed in same direction as blade rotates (wrong way feed). Hands and fingers could be pulled along with workpiece into spinning blade before you can let go or pull back. Fingers, hand or arm could be cut off. Propelled workpiece could hit bystander.

To eliminate risk of wrong way feed:

- ✓ Feed workpiece against blade rotation.
- ✓ Set pawls and spreader; they act as partial barrier to outfeed side.



Guard Nose Function

The guard nose (hold down) must be set correctly during ripping to act as a partial barrier against the infeed side of the blade, to help keep the workpiece flat on the table, and to deflect workpiece chips. It must be lowered to just clear the workpiece.

The guard nose must be re-set each time a different thickness workpiece is cut. Follow the Ripping Set-Up Procedure to correctly set the guard nose. Set guard nose first, then set pawls and spreader.

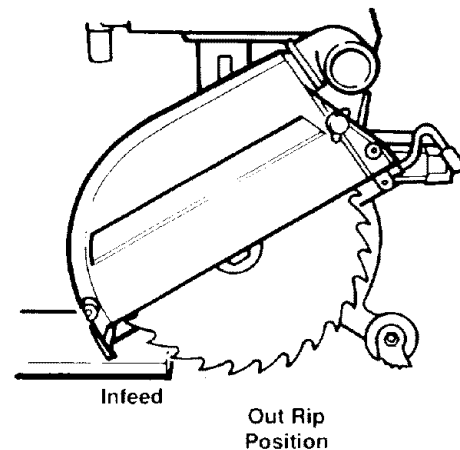

Pawls and Spreader Function

The pawls and spreader must be set correctly during ripping to reduce the risk of kickback, to prevent wrong way feed, and to act as a partial barrier to the hazardous outfeed side of the blade.

The spreader rides in the workpiece kerf to keep it open. This reduces the chances that the cut workpiece will spring closed and pinch the blade. Pinching the blade is a cause of kickback.

The pawls rest level on the upper surface of the workpiece. During cutting they allow the workpiece to pass freely from the infeed to the outfeed side, but help stop the kickback motion from outfeed to infeed side by grabbing into the workpiece surface.

The spreader and pawls must be re-set each time a different thickness workpiece is cut. Follow the Ripping Set-Up Procedure to correctly set the pawls and spreader.

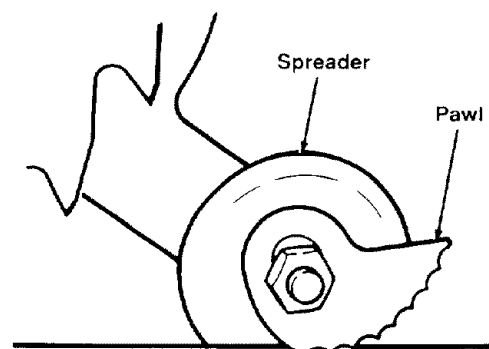
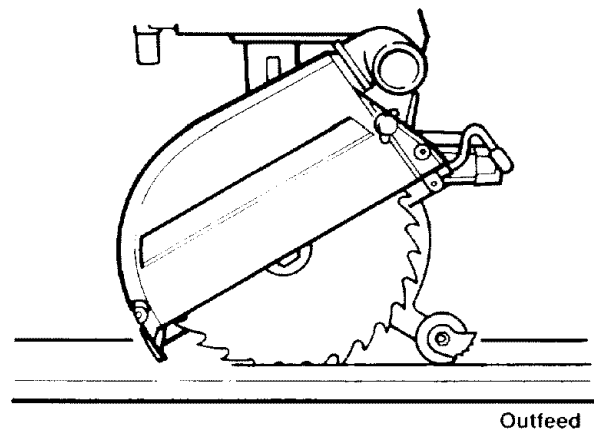

Ripping

Ripping Set-up Procedure

Follow these steps before ripping. These steps must be repeated each time a different thickness workpiece is ripped. A kerf must be made for each different width cut.

1. Prepare table:
 - insert solid (no kerfs) fence (**Note: Use auxiliary fence when blade is set $\frac{1}{2}$ to 2" from fence**)
 - lock table locks.
2. Prepare blade:
 - lock radial arm at 0° miter
 - lock motor at desired bevel angle
 - lock blade in in-rip position*
 - lower blade to just clear table
 - lock blade carriage desired distance from fence. *Make sure widest part of workpiece will be between blade and fence.*

*use out-rip position **only** when blade is set 12" or more from fence

3. Make kerf:
 - i) turn saw on
 - ii) lower blade about $\frac{1}{16}$ " into table
 - iii) turn saw off and remove yellow key.

4. Place workpiece parallel to and up against blade. **Note: Workpiece will be between blade and table front.**

5. Lower guard nose until it just clears top surface of workpiece, then tighten guard clamp screw.

6. Lower pawls and spreader so spreader hangs along side of workpiece, in line with blade, and one set of pawls rests level on workpiece surface, then tighten pawls/spreader wing nut.

7. Test setting: push workpiece toward outfeed side to see that workpiece moves freely; push workpiece toward infeed side to see that pawls grab. **If these conditions are not met, re-set pawls until they are.**

WARNING

If workpiece is pushed along fence with kerfs, workpiece could get caught on kerf, pinch blade and cause kickback. Do not use crosscutting fence for ripping.

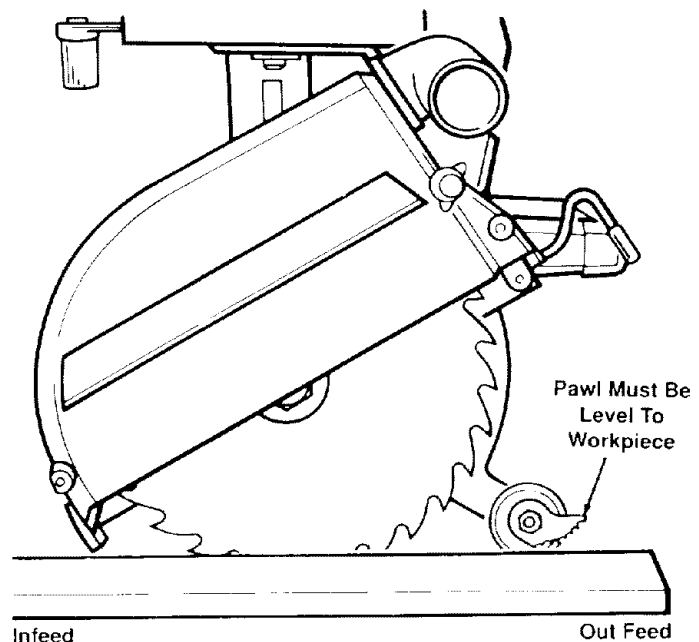
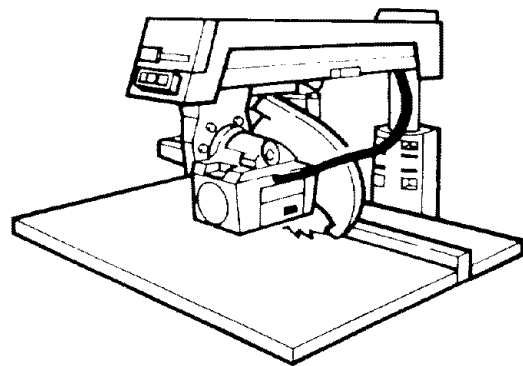

8. Remove workpiece from table.
9. Ready push stick (push block if using auxiliary fence).
10. Set up table extension(s) and support their outer ends. **Do not use another person to support workpieces because this can cause kickback and it exposes helper to potential hazards at outfeed side.**

Making Rip Cuts

Follow these steps to make in-rip cuts. For out-rip cuts, reverse hand functions; that is, put right hand on table and use left hand to support and push workpiece.

1. Follow ripping set-up procedure.
2. Insert yellow key and turn saw on.
3. Stand at infeed side and out of line of workpiece, in case of kickback. **Start and finish cut from infeed side.**
4. Put workpiece on table, in front of guard nose, and tight against fence. To hold workpiece in position, put left hand on table, at least 8" in front of guard nose, and lightly press fingers against workpiece. Support workpiece with table extension or right hand.
5. With right hand, push workpiece under guard nose and into blade. Keep left hand fixed on table, applying slight pressure to keep workpiece against fence.
6. Use right hand to continue to apply feed pressure to part of workpiece close to fence. Keep hand at least 8" in front of guard nose.
7. When end of workpiece gets to table, use push stick or block, instead of hand, on part of workpiece between blade and fence to push until workpiece is completely past pawls and spreader.
8. Turn saw off and **wait for blade to stop spinning before touching workpiece.**

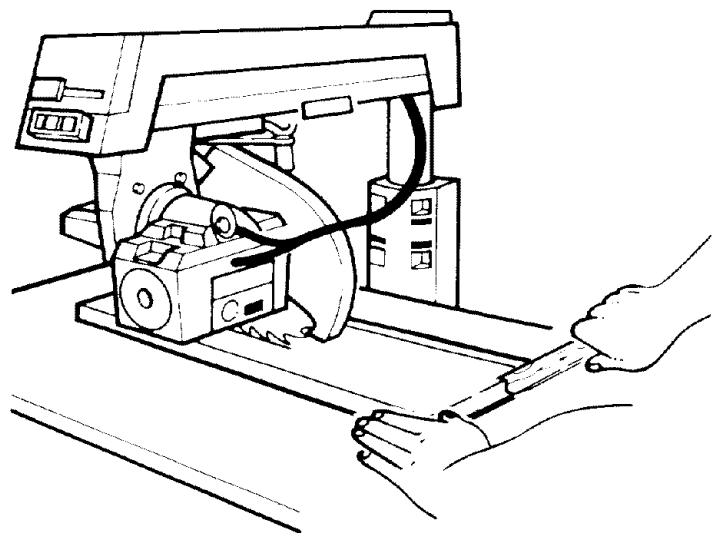
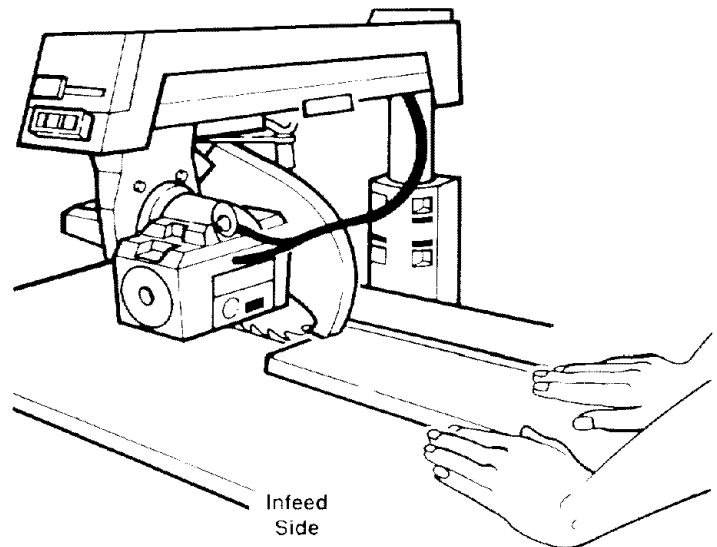
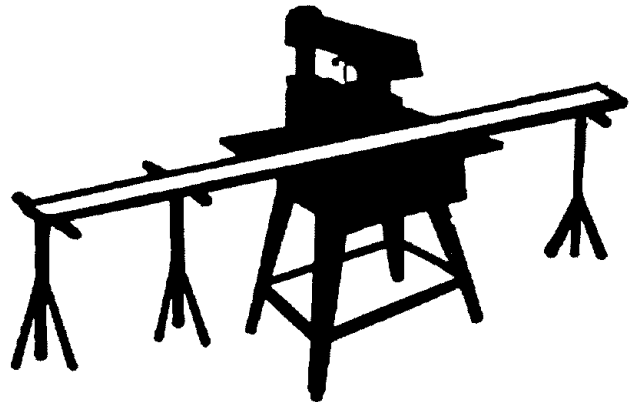

Ripping

Dado Blades, Molding Heads

See Accessories for information on safety, installation and use of dado blades and molding heads.

Edging

Edging is the use of a dado blade or molding head in the horizontal position. It is an advanced technique that requires a molding head guard and a special fence. See Accessories for information on safety, installation and use of dado blades and molding heads for edging. See Cutting Aides for information on making the special fence.

▲ DANGER

Edging without a guard could bring hands and fingers too close to cutting tool.

Hands, fingers, and arm could be cut off.

- **buy, install, and follow instructions for molding head guard**
- **use only dado or molding head for edging**
- **do not use blade because blade cannot be guarded when horizontal**
- **read and follow instructions in Accessories section of manual.**

Ripping Hints

1. To extend life of table top, buy an auxiliary table cover (see Accessories), or make one out of 1/4" plywood or fiberboard. Clamp or nail to original table top, section by section. If you use nails, nail in the four corners to make sure blade will not contact nails.
2. Keep table clean of chips and sawdust.
3. Use sharp blades.
4. Use the right blade for each job.
5. For workpiece with one smooth and one rough surface, such as paneling or finished fiberboard, cut with rough surface up so pawls will be more likely to grab in case of kickback.
6. To keep cut line accurate, periodically check blade alignment.
7. If you must cut an irregular workpiece, attach a straight edge (see Cutting Aides).

Cutting Aides

Cutting aides include push sticks, fences, auxiliary fences, push blocks, featherboards, and straight edges.

Push Sticks

To make a push stick, use $\frac{3}{4}$ " knot-free lumber, or a standard 1x2. Cut to dimensions shown (inches).

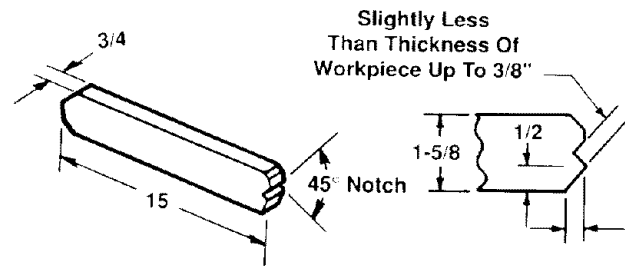

Fences

Fences are required for all saw operations.

To make a fence, use $\frac{3}{4}$ " knot-free lumber cut to table length. Do not use particle board or other composite materials because they are not strong enough. **Note:** *Installed fence must be at least half as high as the workpiece, and never less than $\frac{3}{4}$ ". The fence can be as high or higher than the workpiece.*

Auxiliary Fence and Push Block for Ripping

An auxiliary fence must be used when making very narrow rip cuts that don't allow enough room for a push stick without bringing it too close to the blade. An auxiliary fence must always be used with a push block.

To make an auxiliary fence, use one piece of $\frac{3}{8}$ " plywood and two pieces of $\frac{3}{4}$ " plywood. Cut to dimensions shown (inches). Glue pieces together, and reinforce with nails.

To make a push block, use one piece of $\frac{3}{4}$ " plywood and one piece of $\frac{3}{8}$ " plywood. Cut to dimensions shown (inches). Glue pieces together and reinforce with nails.

Lay the push block on top of the auxiliary fence to make sure their widths match exactly, and are each $4\frac{3}{4}$ ".

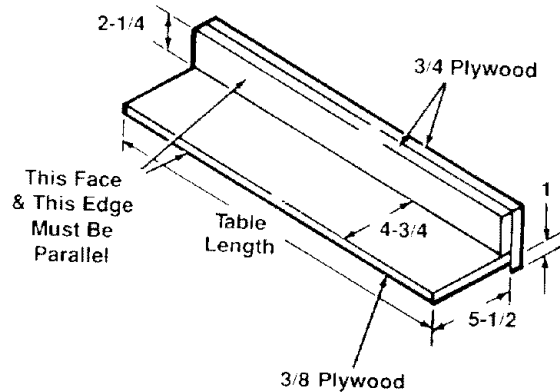

Cutting Aides

Auxiliary Fence for Edging

You must use an auxiliary fence for edging because you cannot completely locate the cutting tool behind a rip fence. Also, edging requires the use of a molding head guard (see Accessories).

To make an auxiliary fence for edging, use $\frac{3}{4}$ " knot-free lumber. Cut two pieces to dimensions shown (inches). To form fence, glue both pieces at right angles to a piece of lumber $\frac{3}{4}$ " x 1". Reinforce with nails.

Install the fence in the front position. Reverse order of rear and spacer tables, because to use molding head or drum sander with arbor vertical, you may have to make a 3" x $3\frac{1}{2}$ " opening in rear table for arbor clearance in order to get cutting tool closer to table. (Spacer table is too narrow for such an opening.)

Note: Initial edge cut will round angled edges of fence.

Note: When using drum sander, vacuum motor often to prevent sawdust/powder build-up, because powder interferes with motor ventilation and can clog starter switch.

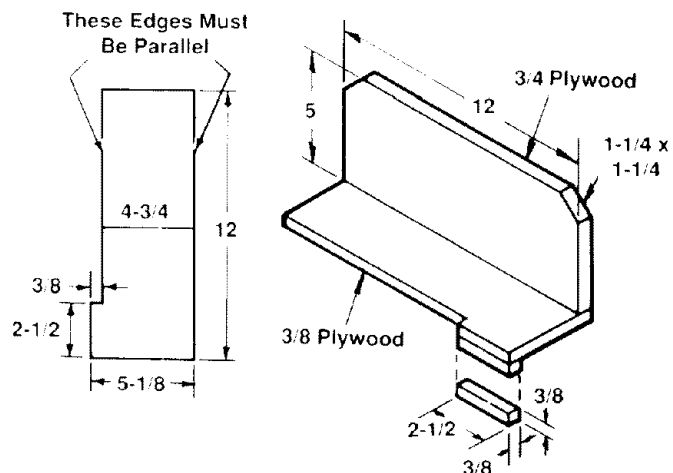
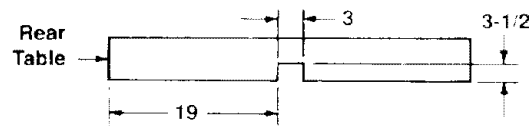
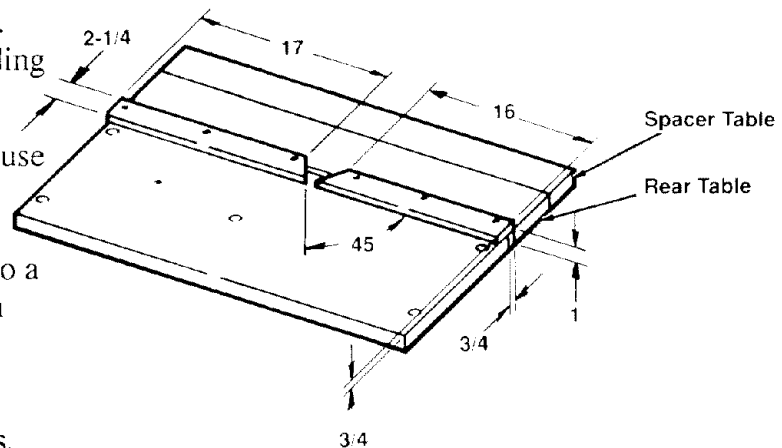

Featherboard

Use a featherboard on the infeed side during ripping to help keep the workpiece against the fence.

To make a featherboard, use knot-free $\frac{3}{4}$ " lumber $5\frac{1}{2}$ " wide. Miter crosscut lumber at a 30° angle to 24". Rip to make 5" long cuts about $\frac{1}{4}$ " apart.

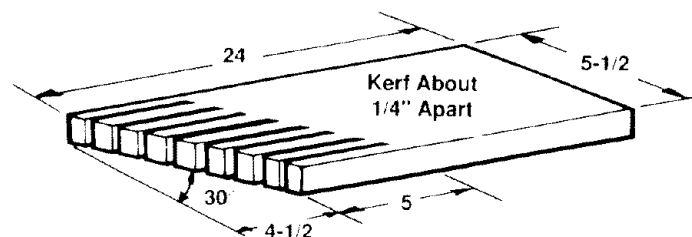

Cutting Aides

Clamp the featherboard to the front table, so that the angled edge of the featherboard is against the workpiece on the in-feed side of the blade. Do not clamp the featherboard against the cut off part (out-feed side) of the workpiece. If clamped to the outfeed side, the featherboard can squeeze the kerf closed, put binding pressure on the blade, and cause kickback.

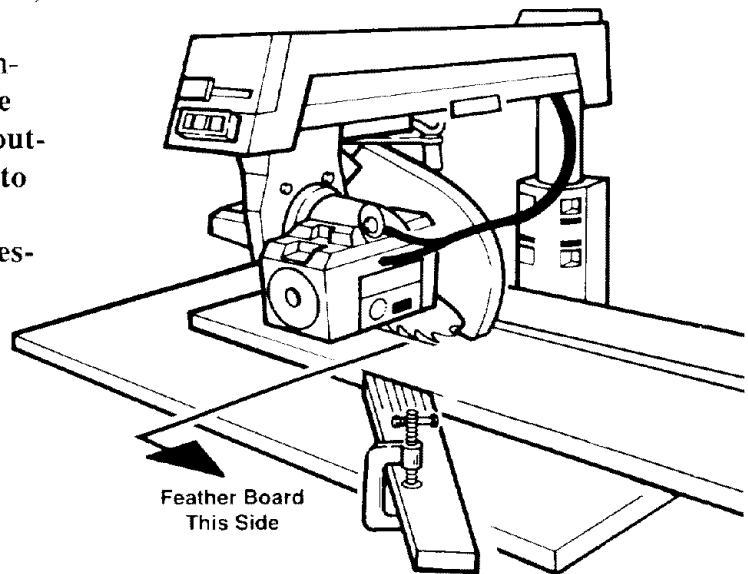

Straight Edge for Irregular Workpiece

WARNING

If you try to rip an irregular workpiece, it could bind blade and cause kickback.

If the workpiece you want to rip does not have a straight edge, attach a straight-edged board to the workpiece:

- i) place irregular side of workpiece against fence
- ii) put straight-edged board on top of workpiece and against fence
- iii) tack straight edged board to workpiece.

Note: Straight-edged board must not extend beyond leading end of workpiece and should cover workpiece width only enough to pass between blade and fence.

Note: Use fence at least as high as combined heights of workpiece and straight-edged board.

Accessories

Accessories Safety

1. Use only accessories listed in this section. Use of any other accessory or attachment might increase the risk of injury to you or others.
2. Read and follow instructions that come with accessory.
3. Do not install accessories on both ends of arbor shaft at same time.
4. Do not use twist drill bits longer than 7" because they can bend and break.
5. Use a spade type drill 1" or smaller in diameter for drilling only wood or plastic.
6. Do not use reduced shank drills.
7. Remove blade wrenches before turning saw on.

DANGER

Grinding wheels, abrasive or cut off wheels, or wire wheels can break explosively and throw pieces. You can be blinded or receive a life threatening puncture wound. Do not use grinding wheels, abrasive or cut off wheels, or wire wheels.

WARNING

When using accessory shaft, exposed arbor shaft can pull in clothing, hair or jewelry as it rotates. Broken bones and severe cuts could occur.

Follow personal safety instructions. Locate arbor shaft under radial arm: lock blade carriage in out-rip position, then bevel motor to -90°.

Information for Dado

1. Put inside loose collar on arbor shaft first, then install dado. Tighten blade nut directly against outside surface of dado.

2. Saw arbor is designed for dado up to 1 $\frac{3}{16}$ " wide. Use of wider dado could cause dado and blade nut to spin off. To make larger than 1 $\frac{3}{16}$ " wide cut, take several passes with dado.
3. To avoid excessive load on motor when making a 1 $\frac{3}{16}$ " wide cut, limit depth of cut to $\frac{1}{8}$ " in one pass.

Information for Edging

Edging is the use of a dado or molding head in the horizontal position. Edging requires the use of a molding head guard (see Accessories List) and an auxiliary fence (see Cutting Aides).

1. Use molding head guard for edging with molding head and dado blade. Follow instructions that come with guard. Do not edge with a blade.

DANGER

Edging without a guard can bring hands and fingers too close to blade. Hands, fingers and arm could be cut off. Buy, install, and follow instructions for molding head guard.

DANGER

Blade cannot be guarded in horizontal position. Edge with guarded molding head or dado. Do not edge with blade.

2. Install auxiliary fence (see Cutting Aides) to allow positioning of cutting tool behind fence.
3. Whenever possible, edge with arm locked at indexed 0° miter, so blade carriage is more likely to lock firmly.

DANGER

Edging without an auxiliary fence when arm is at 0° miter position prevents complete location of cutting tool behind fence. Make and use auxiliary fence to edge with arm locked at 0° miter.

4. If saw handle gets in way with radial arm locked at 0° miter, edging can be done at 30° left miter. In this position, cutting tool can be located behind either a regular or auxiliary fence.

- i) lock arm at 30° left miter
- ii) unlock swivel lock, move saw handle 90° towards left, so motor surface squarely faces front
- iii) lock swivel lock.

Note: This is not a pre-set indexed blade carriage position. Saw forces may affect swivel lock's ability to hold carriage firmly in place.

5. Before edging, with saw unplugged and yellow key out, turn cutting tool by hand to make sure it does not strike guard or any other part of saw.

Lower Blade Guard

The following safety information and instructions apply to all blades and accessories.

The lower blade guard is required by the Occupational Safety and Health Administration (OSHA) if the radial saw is used commercially. The lower blade guard is intended for use only in repetitive 90° crosscutting.

Repetitive 90° crosscutting is the repeated and continuous cutting of many pieces of lumber to the same length with the saw placed in the 90° crosscut position.

In repetitive 90° crosscutting, the guard may reduce the chance of accidentally touching the blade from the side. This protection is possible ONLY when:

- the blade is in its rearmost position and
- the guard is resting on the table so the leading and trailing teeth of the blade are not exposed from the sides.

The lower guard ONLY provides protection against minor lacerations and bruises that occur from contact with the flat sides of the spinning blade.

WARNING

Lower blade guard will not provide any protection if blade is pulled over your hand, or your hand enters blade path from front or rear of blade. Fingers or hand can be cut or cut off.

WARNING

Remove lower blade guard for ALL other types of cuts except repetitive 90° crosscutting. Using lower guard other than for repetitive 90° crosscutting will increase risk of certain hazards:

- During rip and bevel cuts, the workpiece or narrow cut-off pieces can be pinched between the guard and the blade. Workpiece or cut-off pieces can kickback.
- In the bevel position the blade teeth are fully exposed. Fingers or hand can be cut off.
- Cut off pieces can jam between the guard and blade. Turn saw off and wait for blade to stop before freeing a jammed guard or blade.

Accessories

- Workpiece or cut-off pieces can be violently thrown by the blade. Wear safety goggles.

CAUTION

Lower blade guard can get caught or jam in fence or table kerfs.

Read and follow the warning on the lower outer guard:

**WARNING:
TO AVOID INJURY
SHUT OFF POWER
BEFORE CLEARING A
JAMMED LOWER GUARD**

Accessories for this Saw

These accessories are designed to fit this saw. Read and follow instructions that come with accessory.

Item	Catalog No.
Auxiliary Table Cover	see catalog
Blades (10" with 5/8" hole)	see catalog
Dado Blades	
Adjustable Dado	
7"-24 tooth carbide	see catalog
7"-32 tooth carbide	see catalog
7"-16 tooth carbide	see catalog
8"-48 tooth carbide	see catalog
Satin Cut Dado	
7"	see catalog
8"	see catalog
8" carbide	see catalog
Standard Cut Dado	
8"	see catalog
Drill Chuck & Key	see catalog
Dust Collector	9-29978
Extension Table	see catalog

Molding Heads

7" bits not included	see catalog
7"-27 piece set	see catalog
7"-15 piece set	see catalog
Sanding Wheel -10"	see catalog
Sanding Drum	9-25246
Taper Jig	see catalog

Guards

Lower Retractable Guard For 90° Repetitive Crosscut Only	9-29009
Molding Head Guard -8"	see catalog

Books

Power Tool Know How Handbook	9-29117
------------------------------------	---------

Cabinet Accessories

Caster	9-22254
--------------	---------

General Information

When new, the saw requires no lubrication. The saw has been partially aligned and all bearings are lubricated and sealed for life. In time, in order to keep the saw in good working order, it will be necessary to clean, lubricate and re-align.

WARNING

To avoid shock, burns, or lacerations from accidental start up of saw, turn power switch off and unplug saw before doing maintenance or servicing saw.

Cleaning

Periodically remove any heavy build-up of sawdust that may accumulate on the saw. The absorbing tendency of sawdust will draw lubricants away from the areas where they are needed. Wipe the carriage bearings and track surfaces with a dry or lightly oiled cloth. If packed sawdust and grease build up repeatedly on the carriage bearings, inspect the track wipers for wear and replace if necessary.

To avoid motor damage due to sawdust build-up, which interferes with normal motor ventilation, vacuum the motor often.

Lubrication

Do not lubricate motor bearings, carriage bearings, or the area between the miter locking rings and the column tube. Motor and carriage bearings are sealed and do not need added lubrication.

You can lubricate other points if necessary, but only when sticking or binding occurs. Use a small amount of SAE No 10W-30 automotive engine oil. Excess oil attracts airborne dust and sawdust.

To lubricate swivel index pin:

1. Rotate blade to either rip position.
2. Apply a few drops of oil along index pin, as shown below.

To lubricate bevel index pin:

1. Bevel motor to 45°.
2. Apply a few drops of oil along index pin, as shown below.

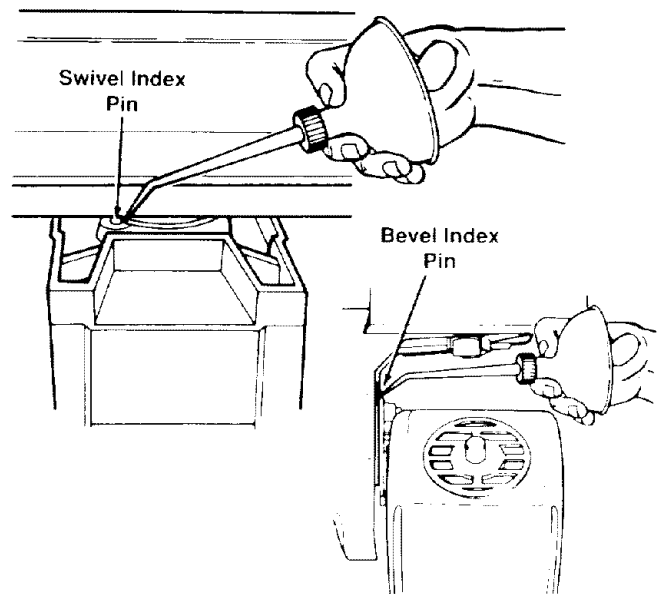

To lubricate the bearing points where the radial arm attaches to the column tube:

1. Remove rear arm cover.
2. Apply oil to two areas indicated by arrows. **Note:** Do not get oil on locking ring; oil will make it slippery and unable to lock securely in non-indexed miter positions.

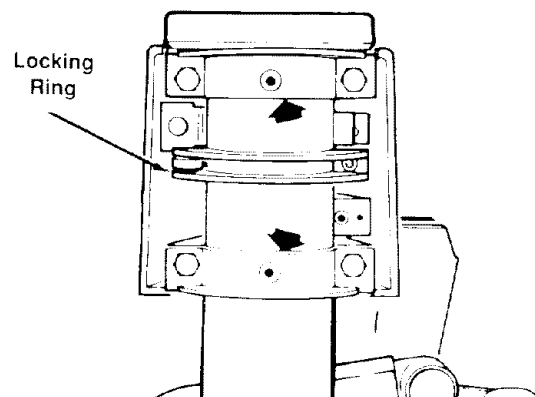

Maintenance

Other areas to lubricate include:

- cam surfaces of the rip lock assembly
- between column tube and column support (*Elevate radial arm to highest point, then wipe face of column tube with light film of oil.*)
- foot assemblies, where foot levers go through foot rods

Adjustments for Wear

Swivel Lock

The swivel lock is a friction lock that prevents play between the casting and blade carriage. If the carriage can be moved by hand when the lock is locked, adjust:

1. Unlock swivel lock.
2. Remove screw and nut from swivel lock knob.
3. **Note:** *Lever portion of swivel lock contains wrench used to make this adjustment.* Separate wrench from lever by turning wrench a few degrees counter-clockwise to release tab.
4. Position wrench across corners of square nut and move wrench to line up with lever.
5. Test adjustment: hold wrench in place, move blade carriage to a non-indexed position, and lock swivel lock. Try to move blade carriage by hand. If you can, further tighten square nut.
6. Unlock swivel lock and move blade to rip position. If carriage does not "snap" securely into pre-set position, loosen square nut one quarter turn.
7. Re-install wrench and knob.

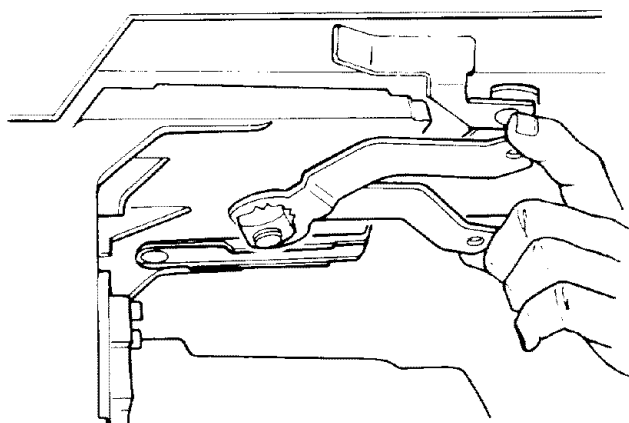
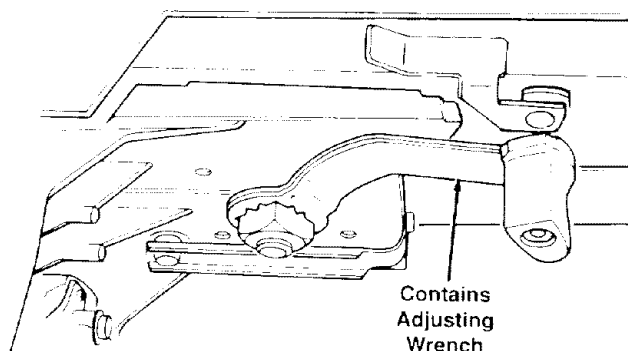

Bevel Lock

If the motor can be moved by hand when the bevel lock is locked, if the lock offers little resistance when being locked, or if the space between the lock lever and casting is different from approximately $\frac{1}{16}$ ", adjust according to step 10 in Mount Motor section of Assembly.

Carriage Bearings

The carriage should roll freely but with some resistance for the entire length of travel. If the carriage moves too freely or with too much resistance, adjust the bearings according to the instructions in Alignment and Adjustment.

Arm and Column

If you can move the end of the radial arm up and down when the arm is **unlocked** between 0 and 45° miter, adjust:

1. Remove rear arm cover.
2. Evenly tighten top two hex head tapping screws, then tighten bottom two hex head screws, but not as tightly as the top ones.
3. Re-install rear arm cover.

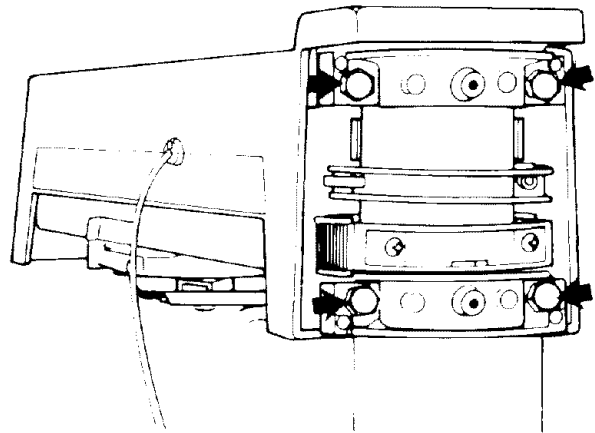

Miter Lock

If the radial arm can be moved side to side by hand when locked between 0 and 45° miter, adjust:

1. Unlock miter lock and move radial arm to any non-indexed position.
2. Tighten socket cap screw, in rear of arm cover, one quarter turn.
3. Lock miter lock and try to move radial arm. If arm still moves, slightly tighten socket cap screw. If lock is too difficult to lock, slightly loosen socket cap screw.

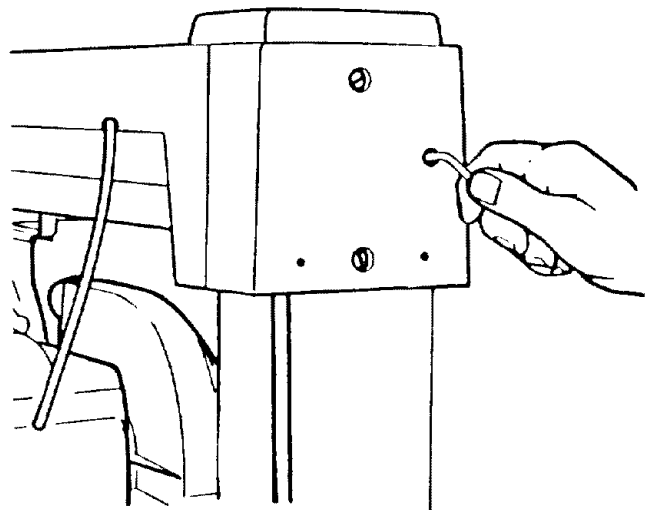

Maintenance

Rip Lock

If the blade carriage can be moved by pushing/pulling on the saw handle when the rip lock is locked, adjust:

1. Hold rip lock in unlocked position and tighten locknut one quarter turn.
2. Test adjustment: if carriage moves with difficulty, slightly loosen locknut; if carriage moves easily, lock rip lock and try to move carriage along arm.

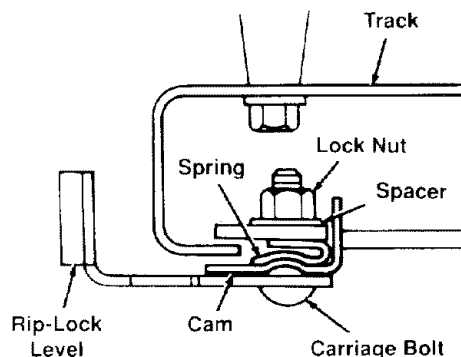

Replacing Pawls

Make sure the teeth of the pawls are always sharp. If they become dull the pawls must be replaced:

1. Remove hex nut and old pawls.
2. Install new pawls and spreader.
3. Align spreader to blade according to instructions in Alignment and Adjustment.

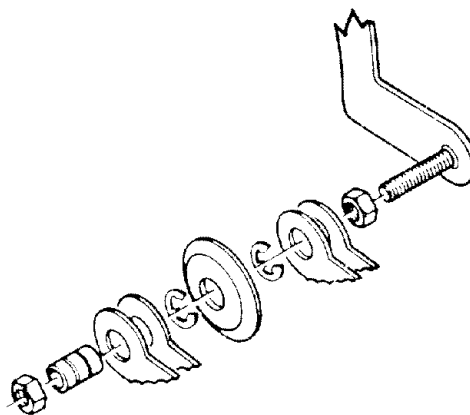

Blade Changing

To change the saw blade:

1. Turn switch off, remove yellow key, and unplug saw.
2. Use both blade wrenches in scissor action to loosen blade nut. **Note:** *Arbor shaft has left-hand threads. Turn nut clockwise to loosen.*
3. Remove nut, blade collar, and blade. Insert new blade, making sure that arrow is on outside and points clockwise.
4. Re-install blade collar and nut. **Note:** *Do not overtighten nut because this can cause blade collar to warp and blade to wobble during cutting.*

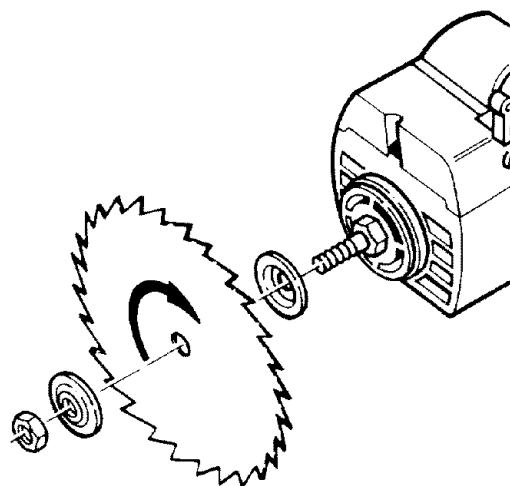

Troubleshooting

Motor Problem	Possible Cause(s)	What to Do
Motor overheats or stalls	Overloaded power line	Reduce line load by removing other lights, appliances
	Feeding rate too fast	Slow rate of feed
	Improper motor cooling	Vacuum sawdust from motor to allow normal air circulation
	Saw blade has heel	Check alignment
While motor is running, fuses blow	Need 15 amp circuit	Call your electrician
	Need 15 amp slow-blow fuse	Install correct fuses
	Low voltage	Check voltage. Normal loads can be safely handled at 10% above or below nameplate voltage; heavy loads need same voltage at motor terminal as on nameplate
Motor starts slowly or fails to come to full power	Incorrect gauge extension cord	Refer to table in Electrical Connections
	Overloaded power line	Reduce line load by removing other lights, appliances
	Undersize wires or circuit too long	Increase wire size or shorten length of wiring
	Sawdust build-up	Vacuum motor
Motor will not run	Protector circuit open	Push re-set button; listen and feel for click
	Low voltage	Check power line for correct voltage
	Sawdust build-up	Vacuum motor
	Bent or bound-up arbor shaft	Check that shaft turns freely by hand; if it doesn't, return to Sears
Fuses blow when motor is turned on	Internal damage	Take saw to Sears for service
Frequent opening of fuses or circuit breakers	Motor overloaded	Slow feed rate
	Fuses or circuit breakers do not have enough capacity	Replace with 15 amp slow-blow fuse or circuit breaker

Troubleshooting

Cutting Problem	Possible Cause(s)	What to Do
Inaccurate cut	Loose locks	Check miter, rip, bevel, and swivel locks. See Adjustments for Wear
	Saw blade out of alignment	Check alignment
Crosscuts not accurate at indexed miter positions	Sawdust between workpiece and fence	Keep front table clean
	Fence not straight	Replace fence
	Swivel lock loose or not locked	Adjust swivel lock for wear
	Crosscut travel not square with fence	Square blade crosscut travel
	Carriage assembly loose on arm	Adjust carriage bearings, then re-align saw
	Arm not indexing properly	Adjust miter lock for wear
	Looseness between column tube and column support	Adjust column support
Depth of crosscut varies from one side of workpiece to other	Table not parallel with radial arm	Level front table
Saw cuts at slight bevel	Blade not square to table	Square blade to table for crosscutting and ripping
	Table not parallel to radial arm	Level front table
	Bevel lock loose	Adjust bevel lock for wear
	Work table not flat	Replace table
	Carriage bearings loose	Adjust carriage bearings, then re-align saw
Workpiece kerf rough with tooth marks from blade	Blade not square to fence	Square blade to fence
	Using improper blade for desired finish cut	Use proper smooth-cutting blade
Blade tends to advance through workpiece too fast during crosscutting	Blade dull	Sharpen or replace blade
	User pulls blade through workpiece too fast	Pull blade slowly and steadily through workpiece

Troubleshooting

Cutting Problem	Possible Cause(s)	What to Do
Workpiece strikes spreader during ripping	Spreader not in line with blade	Align spreader to blade
Workpiece binds, smokes, and motor slows or stops when ripping	Saw blade out of alignment	Re-align
	Warped workpiece	Do not cut severely warped pieces
	Feed rate too fast	Slow feed rate
	Carriage assembly loose	Adjust carriage bearings, then re-align saw
	Fence not straight	Replace fence
Board pulls away from fence during ripping	Dull or incorrect blade	Sharpen or replace blade
	Blade out of alignment	Re-align
	May occur as normal result of applying feed pressure	Use featherboard on infeed side
Saw Problem	Possible Cause(s)	What to do
Radial arm moves when locked in a non-indexed miter position	Miter not locked firmly	Adjust miter lock for wear
Motor moves when bevel lock is locked	Bevel not locked firmly	Adjust bevel lock for wear
Blade carriage moves when rip lock is locked	Rip lock not locked firmly	Adjust rip lock for wear
Blade carriage does not travel smoothly on arm	Dirty track	Clean and lubricate track
	Carriage bearing set too tight	Adjust carriage bearings, then re-align saw
	Rip lock too tight	Adjust rip lock
	Worn arm track	Have Sears replace arm track
	Bad carriage bearing	Replace carriage bearing
Blade does not stop spinning within 15 seconds after saw is turned off	Blade nut loose	Tighten blade nut
	Internal damage	Take saw back to Sears for service

Troubleshooting

Electronics Problem	Possible Cause(s)	What to Do
No display when ON/OFF button pushed	Battery incorrectly installed	Install battery correctly
	Battery contacts dirty	Clean battery contacts
	Dead battery	Replace with 6V, size J battery
	Display failure	Have electronics checked by Sears
Display shows: ele ---	Normal at battery installation	No action
	Reference points not set	Set "0" reference points
	Poor battery contact	Clean battery contacts
	Display failure	Have electronics checked by Sears
Display dim	Low battery voltage	Replace with 6V, size J battery
	Saw very cold	Allow saw to warm above 32°F
Display dark	Saw very warm	Allow saw to cool below 120°F
Display blanks after a few minutes	Normal	Push ON/OFF to see display
Display blanks when moving carriage, then re-appears when motion stops	Normal when position is changed rapidly	No action
Display shows: EEE.E or EE.EE	Arm or carriage moved abruptly or too rapidly when display is off	Re-set "0" reference point(s)
Display resets but immediately shows EEE.E or EE.EE when carriage is moved	Defective encoder or display indicator	Have electronics checked by Sears
Display does not change when arm or carriage is moved	Wrong function selected	Select correct function
	Defective encoder or display indicator	Have electronics checked by Sears
Display does not read 0° or 45° at bevel or miter indexes	"0" reference points not set at indexed points	Set "0" reference points
	Miter and bevel encoders not aligned	Align encoders

Blank Page

Repair Parts

PARTS LIST FOR CRAFTSMAN 10" ELECTRONIC RADIAL SAW MODEL NOS. 113.197411 AND 113.197511 AND 113.197611

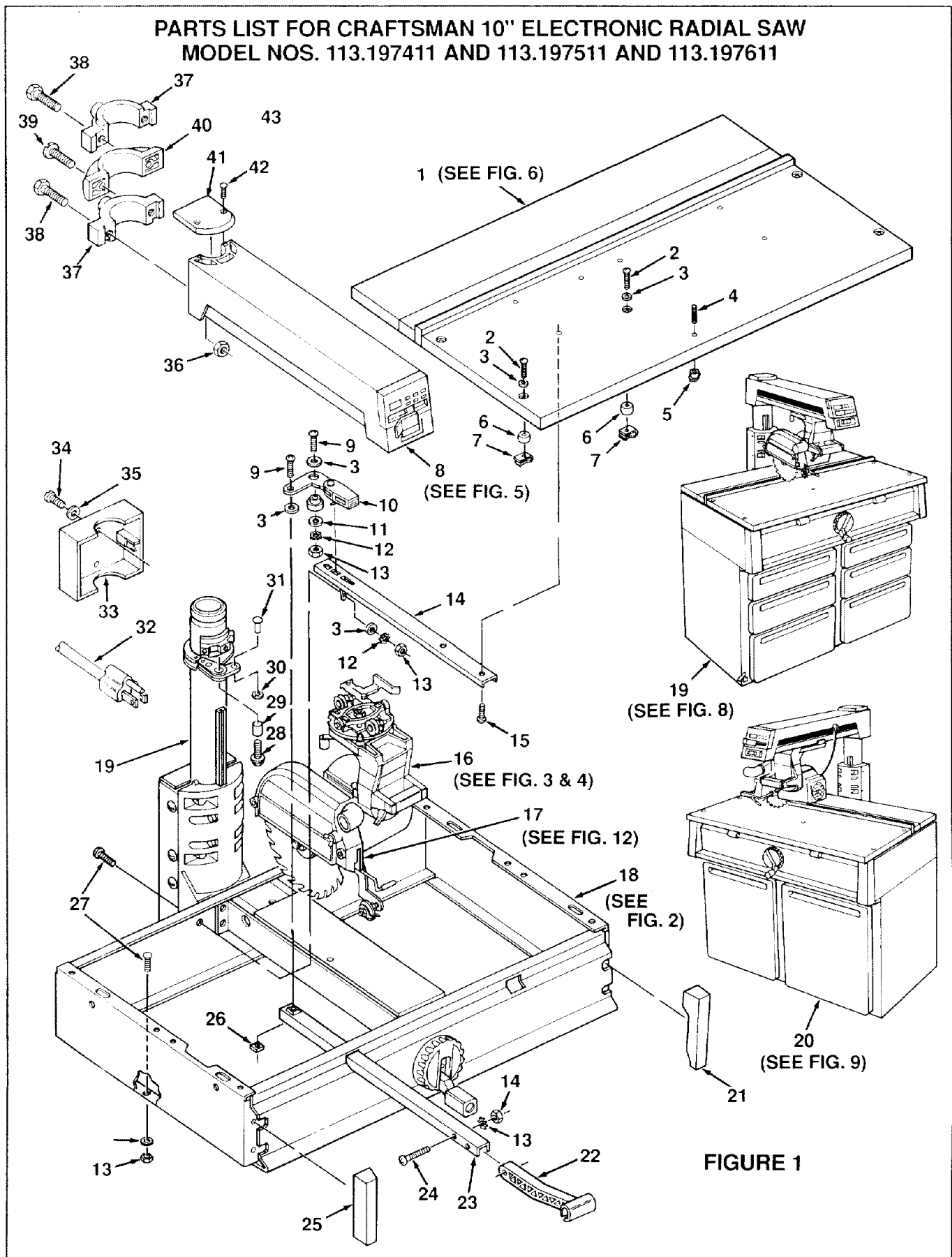

FIGURE 1

Repair Parts

PARTS LIST FOR CRAFTSMAN 10" ELECTRONIC RADIAL SAW MODEL NOS. 113.197411 AND 113.197611 AND 113.197511

Always order by Part Number - Not by Key Number

FIGURE 1

Key No	Part No.	Description	Key No	Part No.	Description
1	—	Table Boards Set (see Fig. 6)	21	818192	Cap, End R.H.
2	806828-4	Screw, Pan Cross Type "T" 1/4-20 x 1-3/4	22	816386	Knob, Bevel Lock
3	STD551012	* Washer, 17/64 x 5/8 x 1/32	23	818200	Actuator, Lock
4	60074	Screw, Hex Socket Set 1/4-20 x 7/8	24	60043	Screw, Pan Cross 1/4-20 x 1-1/8
5	37384	Nut, Tee	25	818193	Cap, End L.H.
6	815762	Bushing, Rubber	26	818247	Nut, Square Lock 1/4-20
7	815989	Clip, "U" 1/4-20	27	60314	Screw, Truss Hd 1/4-20 x 1/2
8	—	Arm Assembly (see Fig. 5)	28	815856-1	Screw, Hex Wash Hd 5/16-18 x 1-1/4
9	STD512507	* Screw, Pan Cross 1/4-20 x 5/8	29	815980	Bushing
10	818181	Slide Assembly, Lock L.H.	30	60208	Nut, Push 1/4
	818180	Slide Assembly, Lock R.H.	31	815774	Rivet 1/4 x 1/2
11	818160	Spacer	32	816114	Cord with Plug
12	STD551225	* Lockwasher, External 1/4	33	815773	Cover, Rear Arm
13	STD541025	* Nut, Hex 1/4-20	34	STD601105	* Screw, Pan Rec. Type "TT" 10-32 x 1/2
14	818190	Channel, Lock Mounting	35	STD551010	* Washer, 13/64 x 7/16 x 1/16
15	815797-1	Screw, Pan Cross Type "AB" 1/4 x 5/8	36	STD541037	* Nut, Hex 3/8-16
16	—	Yoke and Motor Assembly (see Figs. 3 & 4)	37	815649	Bearing, Arm
17	—	Guard Assembly (see Fig. 12)	38	60339	Bolt, Hex Hd 3/8-16 x 2-1/8
18	—	Base and Column Assembly (see Fig. 2)	39	808380-6	Screw, Pan Rec. Hd Plastite No. 8 x 1
19	—	Cabinet Assembly Model 197611 (see Fig. 8)	40	815710	Strap
20	—	Cabinet Assembly Model 197411 (see Fig. 9) and 197511	41	815820	Cap, Arm
			42	STD511107	* Screw, Pan Rec. Hd Type "TT" 10-32 x 7/8
			—	SP5539	Owners Manual (Not Illustrated)

* Standard Hardware Item may be Purchased Locally.

Repair Parts

PARTS LIST FOR CRAFTSMAN 10" ELECTRONIC RADIAL SAW MODEL NOS. 113.197411 AND 113.197611 AND 113.197511

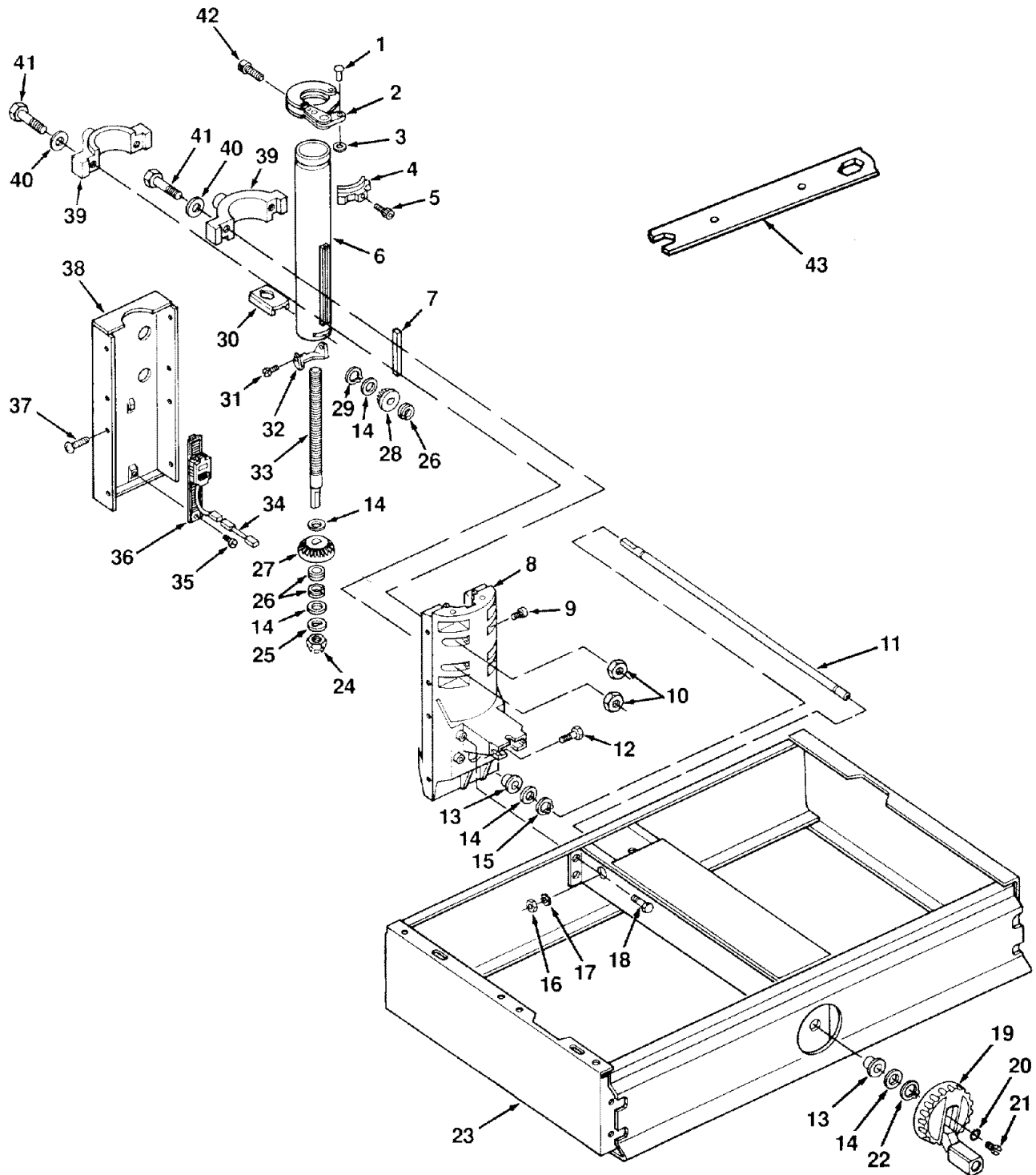

FIGURE 2

Repair Parts

PARTS LIST FOR CRAFTSMAN 10" ELECTRONIC RADIAL SAW MODEL NOS. 113.197411 AND 113.197611 AND 113.197511

Always order by Part Number - Not by Key Number

FIGURE 2 - BASE AND COLUMN ASSEMBLY

Key No	Part No.	Description	Key No	Part No.	Description
1	815774	Rivet, 1/4 x 1/2	23	818216	Base Assembly
2	818198	Lock Assembly	24	STD541450	* Nut, Lock 1/2-13
3	60208	Nut, Push 1/4	25	817106	Washer, Keyed
4	815763	Latch, Arm	26	63614	Bearing Lift Shaft
5	815992-1	Screw, Soc. Hd Type "T" 1/4-20 x 3/4	27	818164	Gear, Bevel
6	818226	Tube	28	818165	Gear, Pinion
7	815770	Gib, Column Tube	29	STD581043	* Ring, Retaining 7/16
8	818212	Support, Column Tube	30	818224	Nut, Elevation
9	817398-1	Screw, Locking Cap 1/4-20 x 5/8	31	STD601103	* Screw, Pan Rec. Hd Type "T" 10-32 x 3/8
10	STD541037	* Nut, Hex 3/8-16	32	815826	Actuator, Elevation
11	818177	Shaft, Elevating Crank	33	818167	Shaft, Elevating
12	STD523107	* Screw, Hex Hd 5/16-18 x 3/4	34	817022	Cord, Elevation
13	815772	Bushing, Elevation	35	STD610803	* Screw, Pan Rec. Hd Type "AB" #8 x 3/8
14	63500	Washer, Thrust .502 x .927 x .031	36	815749-1	Encoder, Elevation
15	STD582050	* Ring, Retaining 1/2	37	815865	Screw, Hex Washer Hd Ty "T" 1/4 - 20 x 1/2
16	STD541031	* Nut, Hex 5/16-18	38	815864	Cover, Column Support
17	STD551131	* Lockwasher, External 5/16	39	815649	Bearing, Arm
18	9416187	Screw, Hex Hd Type "T" 5/16-18 x 3/4	40	60353	Washer, .380 x 47/64 x 1/8
19	816499	Handwheel	41	60339	Bolt, Hex Washer Hd 3/8-16 x 2-1/8
20	STD551210	* Lockwasher, External #10	42	817398-2	* Screw, Socket Hd Cap 1/4-20 x 1-1/4
21	STD511105	* Screw, Pan Hd 10-32 x 1/2	43	3540	Wrench
22	804182	Ring, Retaining			

* Standard Hardware Item may be Purchased Locally.

Repair Parts

PARTS LIST FOR CRAFTSMAN 10" ELECTRONIC RADIAL SAW MODEL NOS. 113.197411 AND 113.197511 AND 113.197611

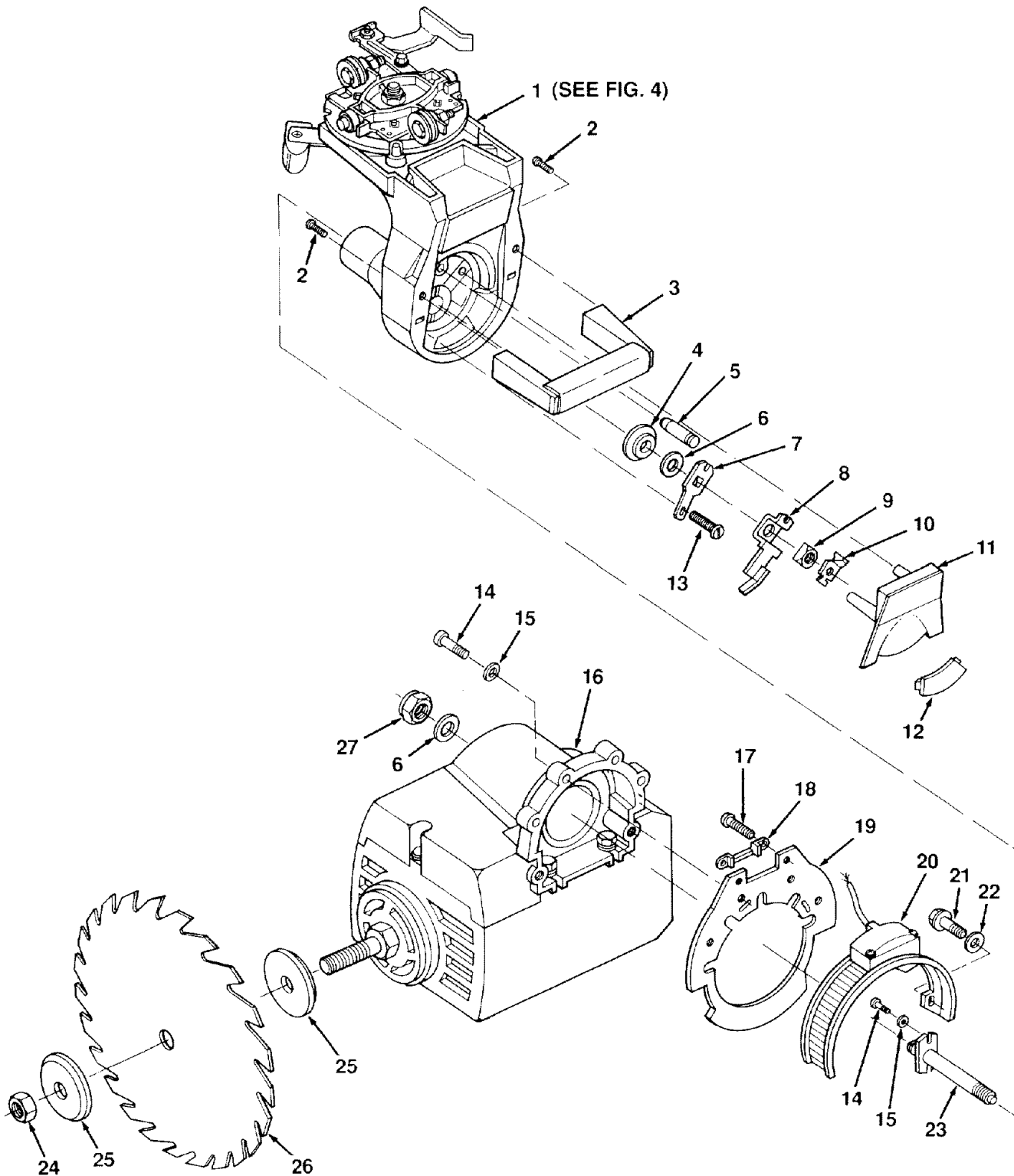

FIGURE 3

Repair Parts

PARTS LIST FOR CRAFTSMAN 10" ELECTRONIC RADIAL SAW MODEL NOS. 113.197411 AND 113.197611 AND 113.197511

Always order by Part Number - Not by Key Number

FIGURE 3 - YOKE AND MOTOR ASSEMBLY

Key No	Part No.	Description	Key No	Part No.	Description
1	—	Yoke Assembly (see Figure 4)	15	STD551012	* Washer, 17/64 x 9/16 x 1/16
2	818922	Screw, Flat Hd Plastite No. 8 x 1	16	818888	* Motor (Complete) (See Fig. 5)
3	818202	Handle, Yoke	17	STD510802	* Screw, Pan Hd Type "T" 8-32 x 5/16
4	815678	Washer, Shaft	18	815802	Guide, Bevel Reader
5	815679-1	Pin, Index	19	818197	Plate, Index
6	STD551043	* Washer, .505 x 7/8 x 1/16	20	815751	Encoder, Bevel
7	815791	Spring, Bevel	21	STD601105	* Screw, Hex Washer Hd Type "T" 10-32 x 1/2
8	818154	Lever, Bevel Lock	22	STD551010	* Washer, 3/16 x 3/8 x 1/32
9	815813	Nut, Square 1/2-13	23	508153	Shaft, Support w/Plate
10	815836	Wedge, Bevel Spring	24	30495	Nut, Shaft
11	818204	Cover, Yoke	25	62498	Collar, Blade
12	815799	Plug, Yoke	26	9-32668	† Blade, Saw
13	806828	Screw, Pan Hd Type "T" 1/4-20 x 1/2	27	805839-1	Nut, Lock 1/2-13
14	815992-1	Screw, Soc. Hd Type "TT" 1/4-20 x 5/8			

* Standard Hardware Item may be Purchased Locally.

† Stock Item may be secured Through the Hardware Department of Most Sears Retail or Catalog Order Houses.

- Any attempt to repair this motor may result in unit misalignment and create a HAZARD unless repair is done by a qualified service technician. Do not loosen the three screws holding the motor support to the motor. This assembly is factory aligned. Repair service is available at your nearest Sears Store.

Repair Parts

PARTS LIST FOR CRAFTSMAN 10" ELECTRONIC RADIAL SAW MODEL NOS. 113.197411 AND 113.197511 AND 113.197611

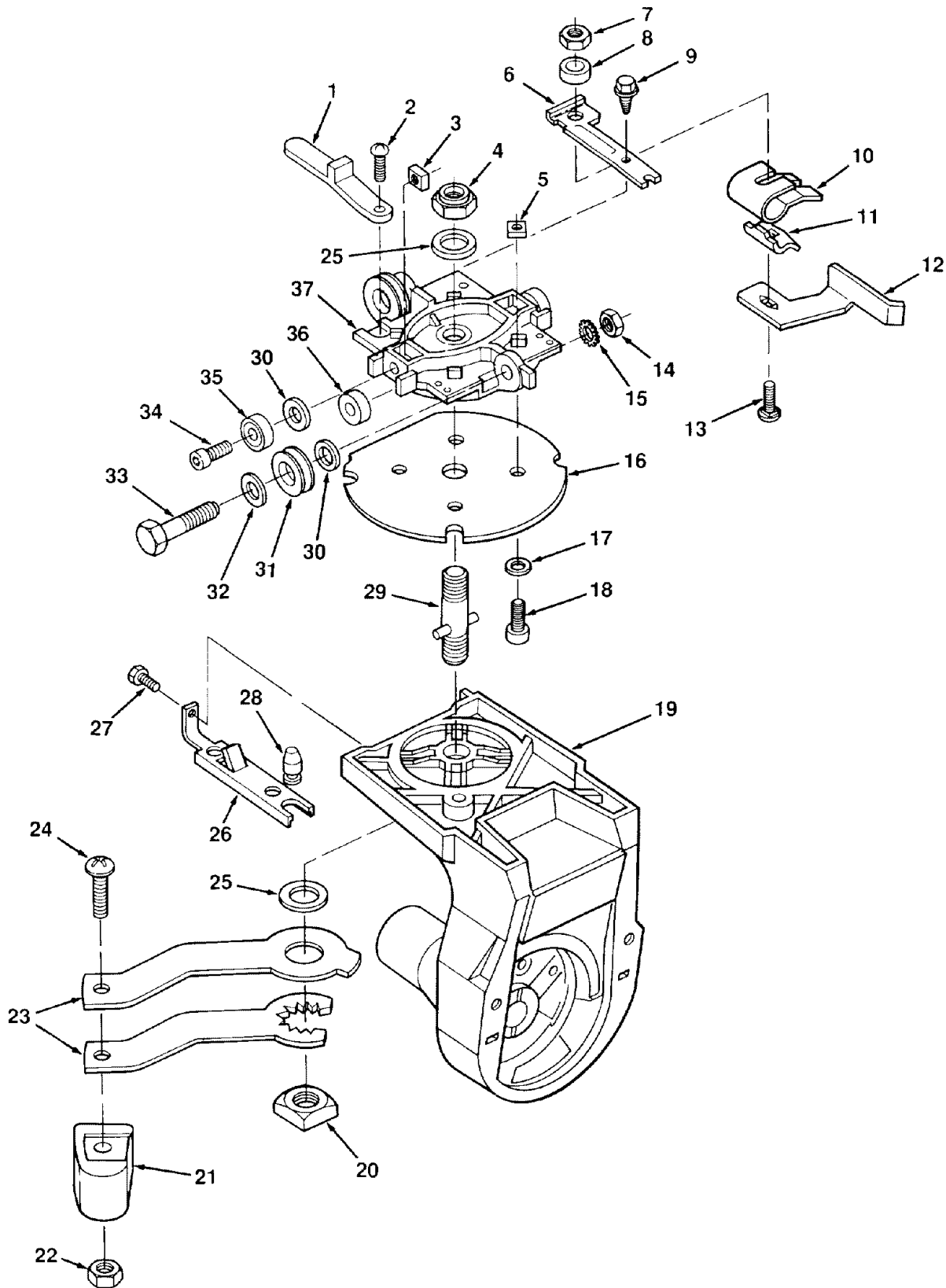

FIGURE 4

Repair Parts

PARTS LIST FOR CRAFTSMAN 10" ELECTRONIC RADIAL SAW MODEL NOS. 113.197411 AND 113.197611 AND 113.197511

Always order by Part Number - Not by Key Number

FIGURE 4 - YOKE ASSEMBLY

Key No	Part No.	Description	Key No	Part No.	Description
1	815827	Actuator, Rip	20	109529	Nut, Square 5/8-11
2	STD600803	* Screw, Pan Rec. Hd Type "T" 8-32 x 3/8	21	816988	Knob, Swivel
3	815817	Nut, Square Lock	22	STD541025	* Nut, Hex 1/4-20
4	STD541462	* Nut, Lock 5/8-11	23	508155	Wrench, Adjustment w/Actuator
5	62636	Nut, Square 1/4-20	24	STD512515	* Screw, Pan Hd 1/4-20 x 1-1/2
6	815693	Bracket, Rip Lock	25	STD551062	* Washer, .630 x 1-1/8 x 3/32
7	STD541425	* Nut, Lock 1/4-20	26	815680	Spring, Swivel
8	62520	Spacer	27	806828	Screw, Pan Hd Type "T" 1/4-20 x 1/2
9	273229	Screw, Hex Hd Type "T" 1/4-20 x 1/2	28	815679-1	Pin Index
10	816497	Spring, Rip Lock	29	815694	Stud, Yoke Clamp
11	815671	Cam, Rip Lock	30	STD551031	* Washer, 21/64 x 5/8 x 1/32
12	818155	Lever, Rip Lock	31	63777	Bearing, Carriage
13	STD532510	* Bolt, Carriage 1/4-20 x 1	32	60438	Washer, No. 2 Carriage Bearing
14	STD541231	* Nut, Hex Jam 5/16-18	33	815807	Screw, Eccentric
15	STD551131	* Lockwasher, External 5/16	34	810214-3	Screw, Low Hd Cap 5/16-18 x 7/8
16	815691	Ring, Yoke Index	35	STD315485	* Bearing, Ball .3150 I.D.
17	STD551012	* Washer, 17/64 x 7/16 x 1/32	36	817181	Wiper, Track
18	817398-1	Screw, Cap Locking 1/4-20 x 5/8	37	815689	Carriage
19	818207	Yoke			

* Standard Hardware Item may be Purchased Locally.

Repair Parts

PARTS LIST FOR CRAFTSMAN 10" ELECTRONIC RADIAL SAW MODEL NOS. 113.197411 AND 113.197511 AND 113.197611

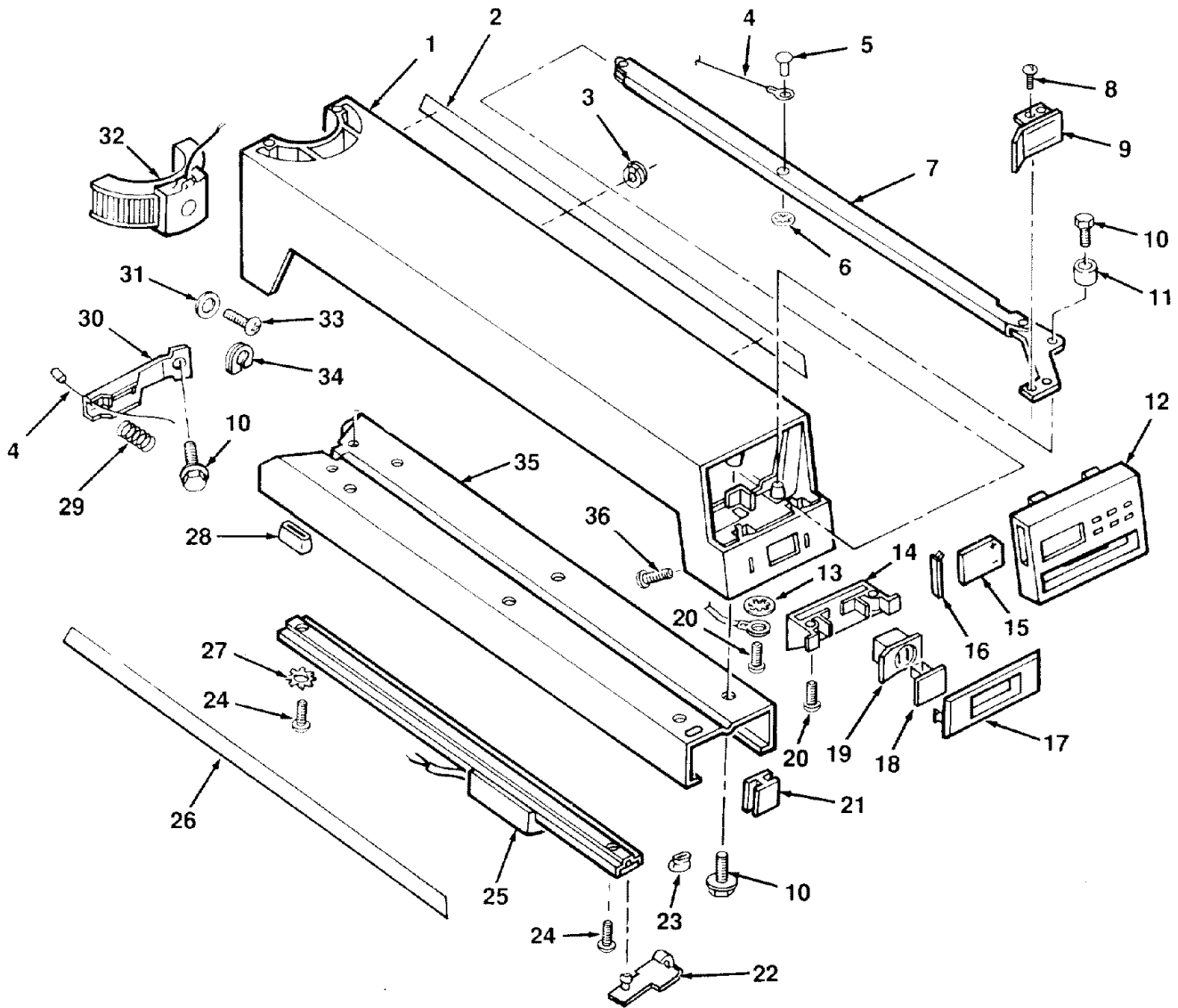

FIGURE 5

Repair Parts

PARTS LIST FOR CRAFTSMAN 10" ELECTRONIC RADIAL SAW MODEL NOS. 113.197411 AND 113.197611 AND 113.197511

Always order by Part Number - Not by Key Number

FIGURE 5 - ARM ASSEMBLY

Key No	Part No.	Description	Key No	Part No.	Description
1	818239	Arm, Radial	21	818521	Bumper, Rubber
2	818536	Label, Trim R.H.	22	816492	Clip, Wire
3	818537	Relief, Strain	23	815789	Strain, Relief
4	815809	Cable	24	816333-3	* Screw, Pan Rec. Hd Type "TT" #10-32 x 5/8
5	815774	Rivet, 1/4 x 1/2	25	816490	Encoder, Rip (Includes Key #23)
6	60208	Push Nut, 1/4	26	815786	Label, Trim L.H.
7	818182	Actuator Assembly	27	STD551210	* Lockwasher, External #10
8	STD601103	* Screw, Pan Rec. Type "T" 10-32 x 3/8	28	816178	Sleeve, Rubber
9	815703	Knob, Miter Lock	29	815867	Spring, Compression
10	9416187	Screw, Hex Washer Hd 5/16-18 x 3/4	30	815708	Spring, Miter Lock
11	815779	Bushing	31	STD551010	* Washer 13/64 x 5/8 x 1/32
12	815741	Controls, R.S.	32	815752	Encoder, Miter
13	STD551208	* Lockwasher, Internal #8	33	808380-10	Screw, Pan Rec. Hd Plastite #10-14 x 3/8
14	815704	Housing, Switch	34	815868	Relief, Strain
15	STD363539	* Battery	35	818088-1	Track, Arm
16	815735	Lid, Battery Access	36	STD610805	* Screw, Pan Rec. Hd #8-10 x 1/2
17	815976	Bezel, Switch			
18	9-22256	†Key, Switch			
19	815775	Switch, Locking			
20	STD600803	* Screw, Pan Rec. Hd Type "T" #8-32 x 3/8			

* Standard Hardware Item may be Purchased Locally.

† Stock Item may be Secured Through the Hardware Department of Most Sears Retail or Catalog Order Houses.

• Can also use these battery numbers:

Eveready #539
Rayovac #867
Duracel #7K67

Repair Parts

PARTS LIST FOR CRAFTSMAN 10" ELECTRONIC RADIAL SAW MODEL NOS. 113.197411 AND 113.197611 AND 113.197511

Always order by Part Number - Not by Key Number

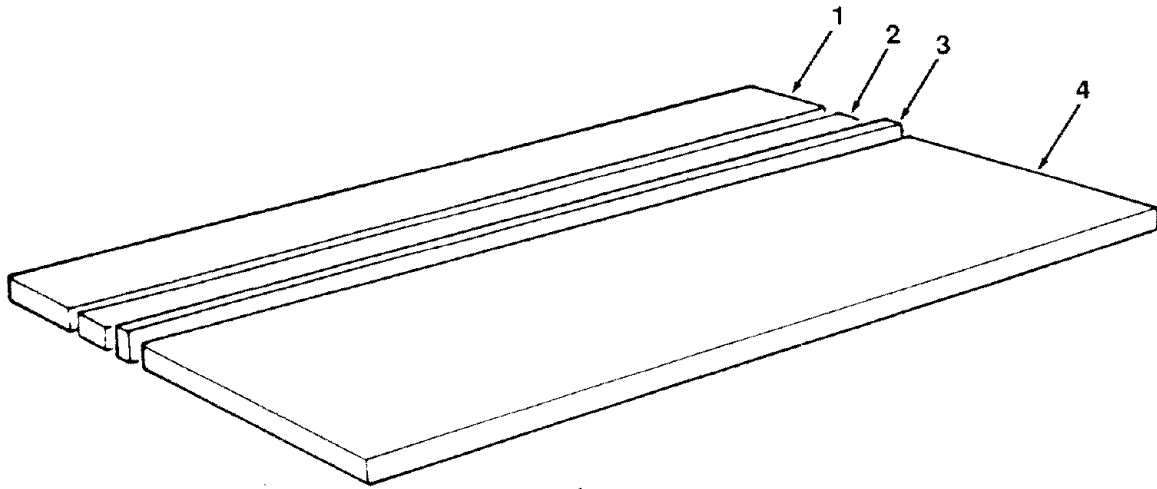

FIGURE 6 - TABLE ASSEMBLY

Key No	Part No.	Description
1	815757	Table, Rear
2	815755	Table, Spacer
3	815758	Fence, Rip
4	818196-1	Table, Front

* Standard Hardware Item may be Purchased Locally.

PARTS LIST FOR CRAFTSMAN 10" ELECTRONIC RADIAL SAW MODEL NOS. 113.197411, 113.197511 AND 113.197611

Always order by Part Number - Not by Key Number

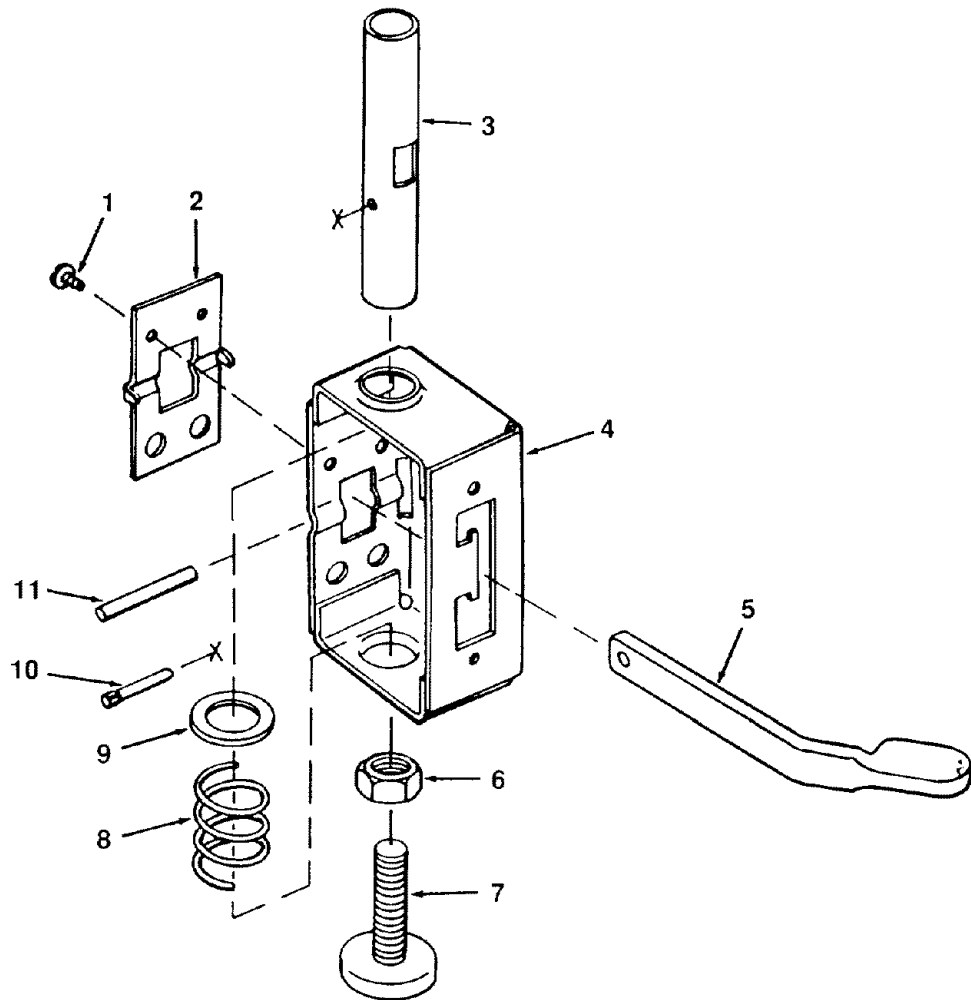

FIGURE 7 - FOOT ASSEMBLY - MODEL 113.197511 & 113.197611

Key No	Part No.	Description
1	STD601103	* Screw, Pan Rec. Hd Type "T" 10-32 x 3/8
2	815874	Retainer, Pin
3	817116	Rod Assembly, Foot
4	815879	Support
5	815871	Actuator, Foot
6	STD541237	* Nut, Hex Jam 3/8-16
7	803835-1	Foot, Leveling
8	815878	Spring
9	815875	Washer
10	803927-3	Pin, Groove
11	808503-1	Pin

* Standard Hardware Item may be Purchased Locally.

Repair Parts

PARTS LIST FOR CRAFTSMAN 10" ELECTRONIC RADIAL SAW MODEL NOS. 113.197411, 113.197511 AND 113.197611

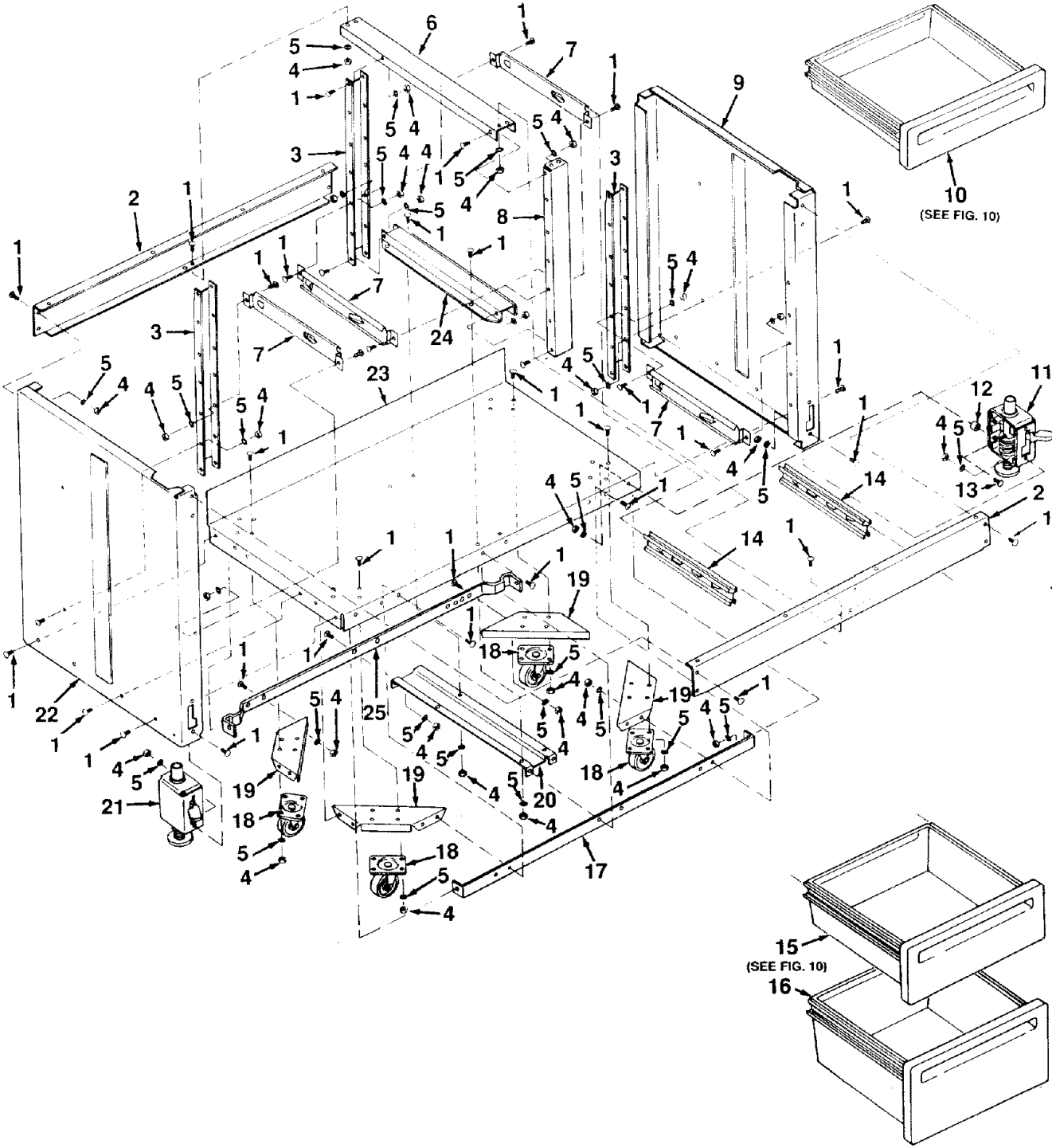

FIGURE 8

Repairs Parts

PARTS LIST FOR CRAFTSMAN 10" ELECTRONIC RADIAL SAW MODEL NOS. 113.197411, 113.197511 AND 113.197611

Always order by Part Number - Not by Key Number

FIGURE 8 - CABINET ASSEMBLY FOR MODEL 113.197611

Key No	Part No.	Description	Key No	Part No.	Description
1	60314	Screw, Truss Hd 1/4-20 x 1/2	15	—	Drawer Assembly 6 in. (see Fig. 10)
2	815898	Skirt 44"	16	—	Drawer Assembly 10 in. (see Fig. 10)
3	815892	Support, Center Rear	17	815942	Stiffener, Shelf
4	STD541025	* Nut, Hex 1/4-20	18	815896	Caster
5	STD551225	* Lockwasher, External 1/4	19	815993	Support, Caster
6	815893	Support, Upper	20	815991	Support, Under
7	815890	Bracket, Stand Slide	21	—	Foot Assembly, L.H. (see Fig. 7)
8	815886	Support, Front Center	22	817150	Panel, Side L.H.
9	817151	Panel, Side R.H.	23	815889	Shelf, Lower 44 in.
10	—	Drawer Assembly, 3 in. (see Fig. 10)	24	815891	Support, Lower
11	—	Foot Assembly, R.H. (see Fig. 7)	25	816336	Stiffener - Shelf Rear
12	802392-36	Spacer			
13	805529-5	Screw, Truss Hd 1/4-20 x 1			
14	815888	Bracket, Center Slide			

* Standard Hardware Item May Be Purchased Locally.

Repairs Parts

PARTS LIST FOR CRAFTSMAN 10" ELECTRONIC RADIAL SAW MODEL NOS. 113.197411, 113.197511 AND 113.197611

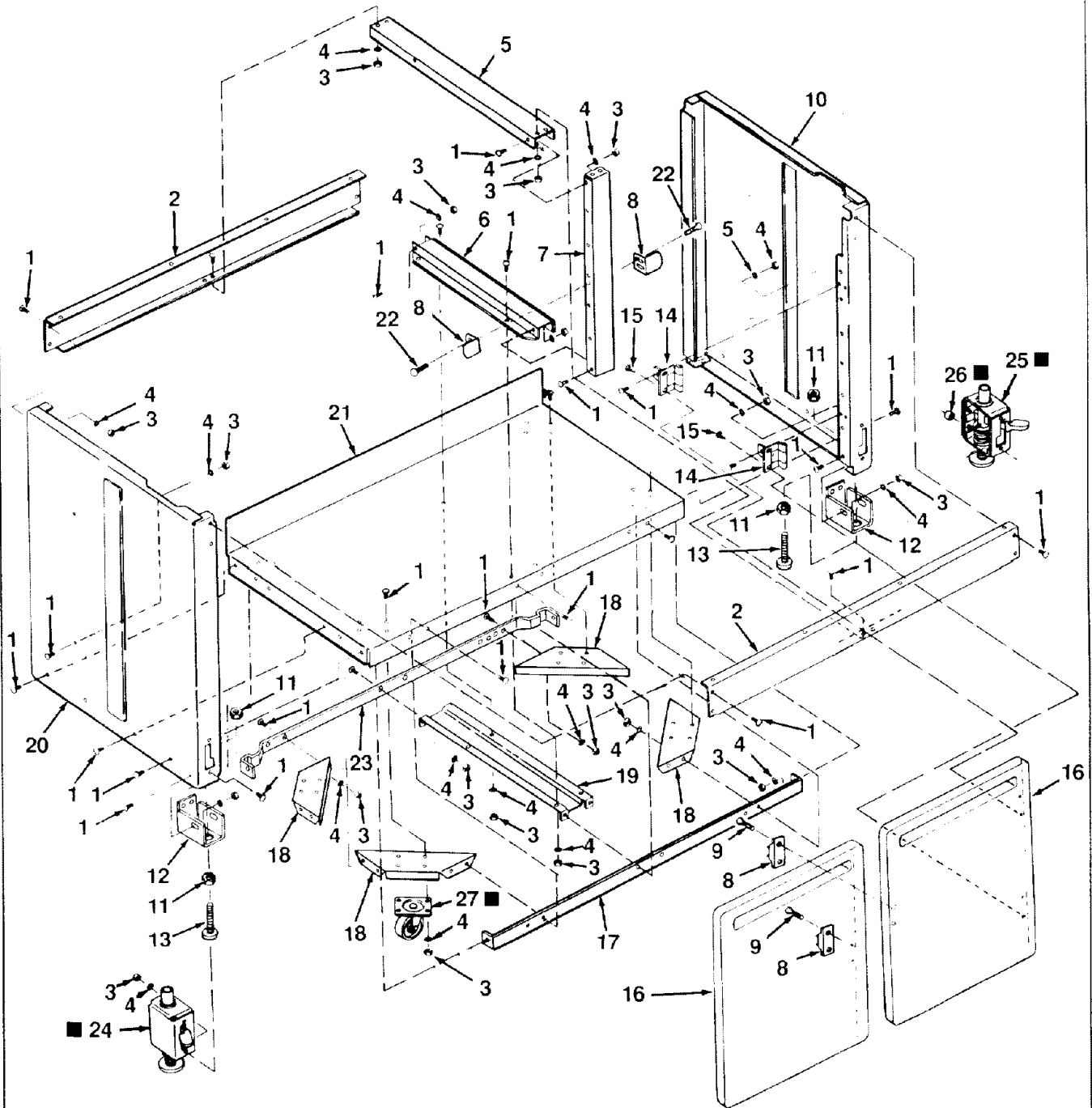

FIGURE 9

Repairs Parts

PARTS LIST FOR CRAFTSMAN 10" ELECTRONIC RADIAL SAW MODEL NOS. 113.197411, 113.197511 AND 113.197611

Always order by Part Number - Not by Key Number

FIGURE 9 - CABINET ASSEMBLY FOR MODEL 113.197411 AND 113.197511

Key No	Part No.	Description	Key No	Part No.	Description
1	60314	Screw, Truss Hd, 1/4-20 x 1/2	16	815882	Door, Cabinet
2	815898	Skirt	17	815942	Stiffener, Shelf
3	STD541025	* Nut, Hex 1/4-20	18	815993	Support, Caster
4	STD551225	* Lockwasher, External 1/4	19	815991	Support, Under
5	815893	Support, Upper	20	817150	Panel, L.H. Side
6	815891	Support, Lower	21	815889	Shelf, Lower
7	815886	Support, Front Center	22	STD600603	* Screw, Pan Hd Type "T" 6-32 x 3/8
8	815933	Catch, Magnetic	23	816336	Stiffener - Shelf Rear
9	816274	Screw, Pan Hd Plastite 6-10 x 1/2	24	—	■ Foot Assembly, L.H. (See Fig. 7)
10	817151	Panel, R.H. Side	25	—	■ Foot Assembly, R.H. (See Fig. 7)
11	STD541237	* Nut, Hex Jam 3/8-16	26	802392-36	■ Spacer
12	817108	Spacer	27	815896	■ Caster
13	803835-1	Foot, Leveling			
14	815934	Hinge, Door			
15	816274-1	Screw, Pan Hd Plastite 10-10 x 1/2			

* Standard Hardware Item May Be Purchased Locally.

■ Model 113.197511 Only

Repairs Parts

PARTS LIST FOR CRAFTSMAN 10" ELECTRONIC RADIAL SAW MODEL NOS. 113.197411, 113.197511 AND 113.197611

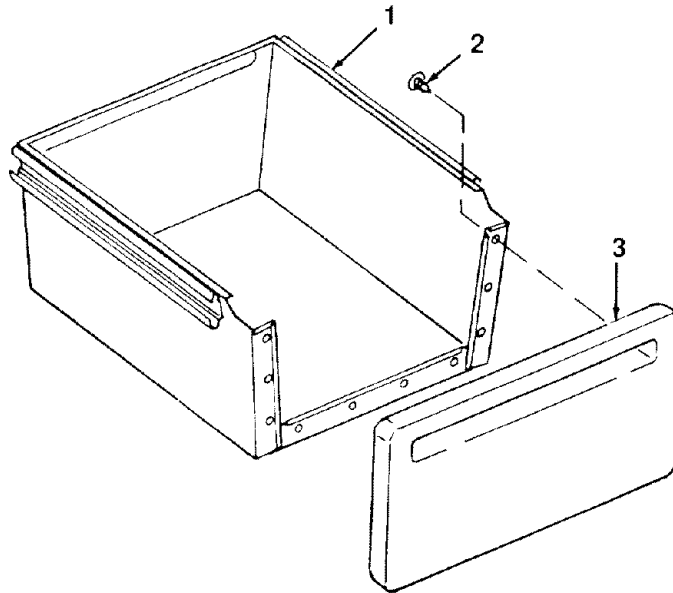

Always order by Part Number - Not by Key Number

**FIGURE 10 - DRAWER ASSEMBLIES 3", 6", 10"
FOR MODEL 113.197611**

Key No	Part No.	Description
1	815912	Drawer Assembly, 3"
	815917	Drawer Assembly, 6"
	815919	Drawer Assembly, 10"
2	330751	Fastener
3	815923	Drawer Front, 3"
	815901	Drawer Front, 6"
	815902	Drawer Front, 10"

* Standard Hardware Item may be Purchased Locally.

PARTS LIST FOR CRAFTSMAN 10" ELECTRONIC RADIAL SAW MODEL NOS. 113.197411, 113.197511 AND 113.197611

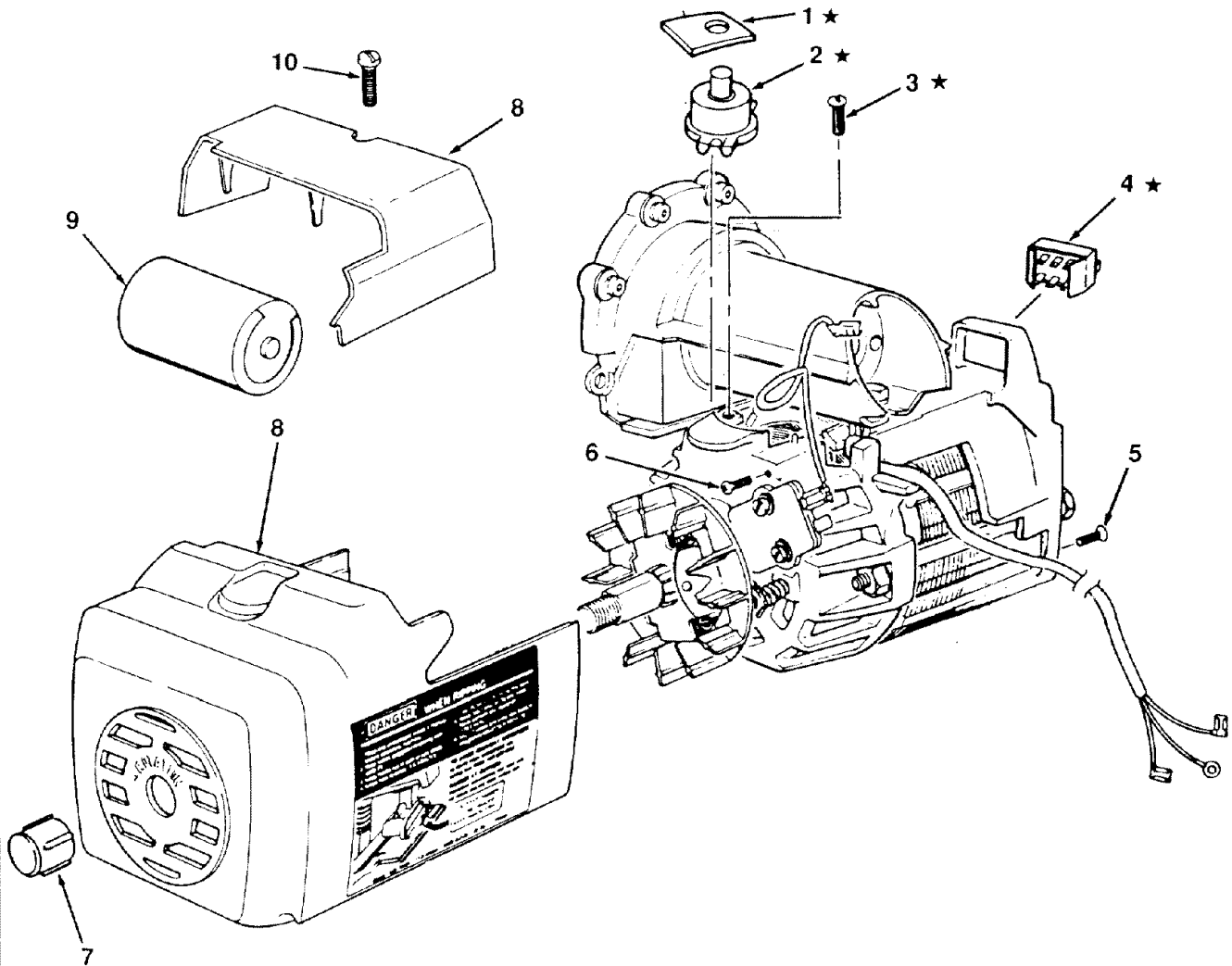

Always order by Part Number - Not by Key Number

FIGURE 11 - MOTOR ASSEMBLY

Key No	Part No.	Description
1	64922	Gasket
2	64921	Protector
3	STD600603	* Screw, Type 23 Pan Hd 6-32 x 3/8
4	64909	Switch, Slide
5	64951	Screw, Flat Head
6	64948	Screw, Ground
7	30582	Cap, Shaft
8	507744	Housing, Motor
9	STD376116	* Capacitor
10	64950	Screw, Type "T"

* Standard Hardware Item may be Purchased Locally.

Repairs Parts

PARTS LIST FOR CRAFTSMAN 10" ELECTRONIC RADIAL SAW MODEL NOS. 113.197411, 113.197511 AND 113.197611

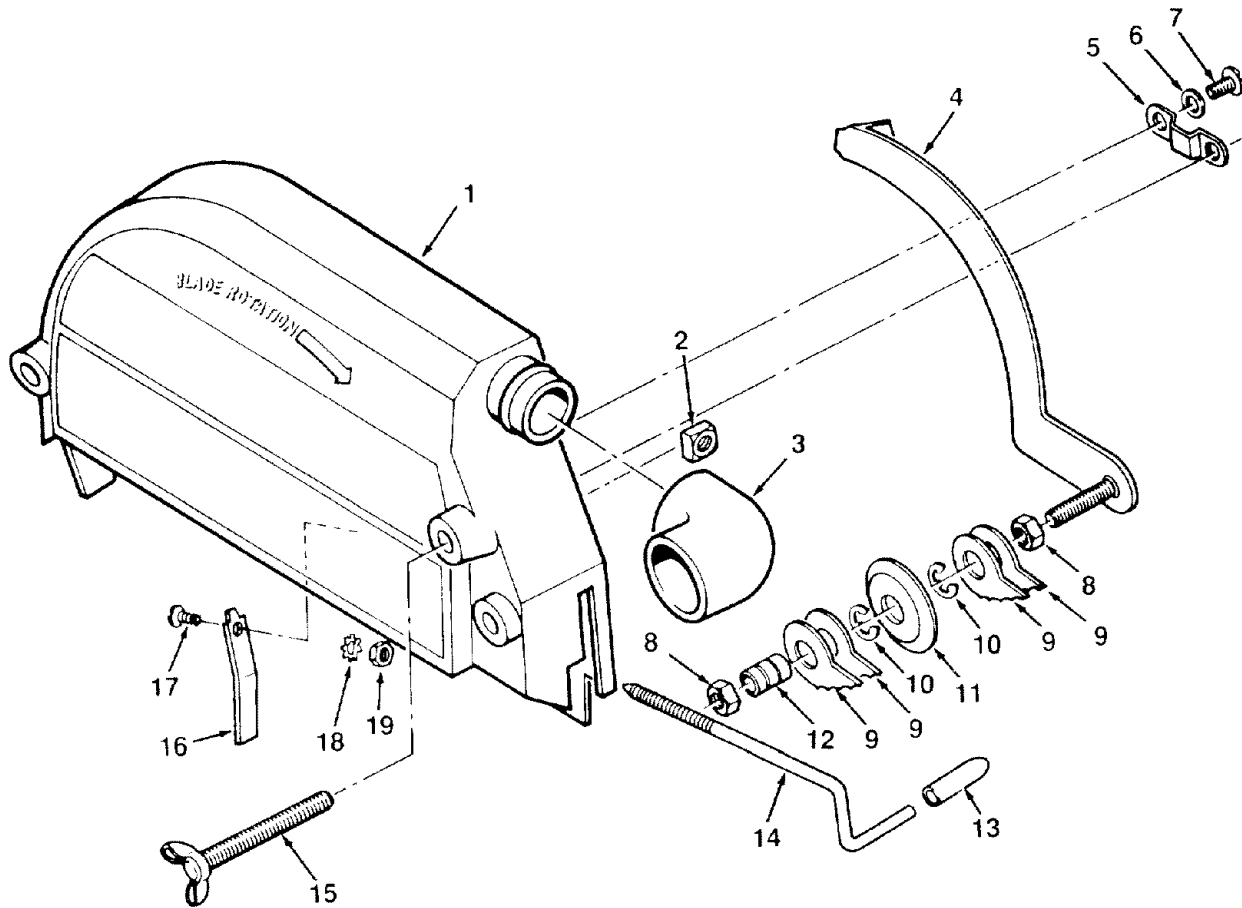

FIGURE 12 - GUARD ASSEMBLY

Always order by Part Number - Not by Key Number

Key No	Part No.	Description
1	816264-1	Guard
2	120399	* Nut, Square 5/16-18
3	63258	Elbow, Dust
4	63541	Bar, Anti-Kickback
5	815816	Guide, Anti-Kickback
6	STD551010	* Washer, 13/64 x 5/8 x 1/32
7	STD601103	* Screw, Pan Hd Type "T" 10-32 x 3/8
8	STD541231	* Nut, Hex Jam 5/6-18
9	815815	Pawl

Key No	Part No.	Description
10	STD581050	* Ring, Retaining
11	63270	Spreader
12	816341	Bearing (Includes Key #10)
13	60435	Grip
14	816070	Screw, Guard Clamp
15	166785-3	Screw, Wing 5/16-18 x 2-3/4
16	63538	Clamp, Guard
17	STD510805	* Screw, Pan Hd 8-32 x 1/2
18	STD551208	* Lockwasher, External No. 8
19	STD541008	* Nut, Hex 8-32

* Standard Hardware Item may be Purchased Locally.

- Accessories 72
 - Item List 74
- Adjustment
 - Arm & Column 77
 - Bevel Lock 28, 77
 - Carriage Bearings 44, 77
 - Column Support 37
 - Leveling Feet 29
 - Miter Lock 77
 - Rip Lock 78
 - Swivel Lock 76
- Alignment
 - Blade to Fence 42
 - Blade to Table (Parallel) 45
 - Blade to Table for Crosscut 40
 - Blade to Table for Rip 43
 - Crosscut Travel 39
 - Spreader to Blade 46
- Blade
 - Change 78
 - Install 40
 - Safety 7
- Carriage Bearings 44, 77
- Carriage Stop 60
- Cleaning 75
- Controls 34
- Conversion Table
 - Decimal/Fraction 53
- Crosscutting
 - Definition 57
 - Hints 60
 - Kerfs 58
 - Making Crosscuts 59
 - Repetitive 60
 - Safety 57
- Cutting Aides 69
- Dado 68, 72
- Digital Display
 - Align Encoders 50
 - Battery 49
 - Error Messages 48
 - Function 48
 - Set "0" Reference Points 51
- Edging 72
- Electrical Connections 54
- Extension Cords 55
- Featherboard 70, 71
- Fences
 - Auxiliary for Edging 70
 - Auxiliary for Ripping 69
 - Crosscut/Rip 69
- Guard
 - Function/Operation 36, 65
 - Guard Clamp Screw 36
 - Install 46
 - Lower Blade Guard 73
 - Molding Head Guard 68, 72
- Hints
 - Crosscutting 60
 - Ripping 68
- In-rip 61
- Infeed 61
- Kerfs
 - Crosscut 58
 - Ripping 66
- Kickback 4, 63
- Length Stop 60
- Level Front Table 38
- Leveling Feet 29
- Locks
 - Bevel 28, 34, 77
 - Miter 34, 77
 - Rip 35, 78
 - Swivel 35, 76
 - Table 34
- Lower Blade Guard 73
- Lubrication 75
- Maintenance
 - Adjustments for Wear 76
 - Cleaning 75
 - General 75
 - Lubrication 75
- Molding Head 68
- Molding Head Guard 68, 72
- Motor
 - Changing Voltage 56
 - Reset Button 55
 - Specifications 54
- Out-rip 61
- Outfeed 61
- Outfeed Zone Hazard 3, 63
- Pawls/Spreader
 - Function/Operation 36, 65
 - Replace Pawls 78
 - Setting 36
 - Setting for Crosscut 57
 - Setting for Rip 65
- Push Blocks
 - Making 69
 - Using 62
- Push Sticks
 - Making 69
 - Using 62
- Ripping
 - Definition 61
 - Fence Position 61
 - Hints 68
 - In-rip 61
 - Kerfs 66
 - Making Rip Cuts 67
 - Out-rip 61
 - Safety 62
 - Set-Up Procedure 66
 - Workpiece Position 62
- Safety
 - Accessories 72
 - Blade 7
 - Crosscutting 57
 - General 3
 - Personal 5
 - Ripping 3, 62
 - Saw 6
 - Work Area 5
 - Workpiece 6
- Spreader
 - Alignment 46
 - Function/Operation 36, 65
 - Straight Edge 71
- Table Lock
 - Function/Operation 34
- Wrong Way Feed 4, 64

SEARS

owner's manual

SERVICE

MODEL NO.

113.197411

**10-INCH ELECTRONIC
RADIAL SAW WITH
44-INCH CABINET
AND 2 DOORS**

OR

113.197511

**10-INCH ELECTRONIC
RADIAL SAW
WITH 44-INCH CABINET
AND 2 DOORS AND
CASTERS**

OR

113.197611

**10-INCH ELECTRONIC
RADIAL SAW WITH
44-INCH CABINET
AND 6 DRAWERS**

HOW TO ORDER REPAIR PARTS

10-INCH RADIAL SAW

Now that you have purchased your 10-inch radial saw, should a need ever exist for repair parts or service, simply contact any Sears Service Center and most Sears, Roebuck and Co. stores. Be sure to provide all pertinent facts when you call or visit.

The model number of your 10-inch radial saw will be found on a plate attached to your saw, at the left-hand side of the base.

WHEN ORDERING REPAIR PARTS, ALWAYS GIVE THE FOLLOWING INFORMATION:

PART NUMBER	PART DESCRIPTION
MODEL NUMBER	NAME OF ITEM
113.197411	10-INCH RADIAL SAW
113.197511	
113.197611	

All parts listed may be ordered from any Sears Service Center and most Sears stores. If the parts you need are not stocked locally, your order will be electronically transmitted to a Sears Repair Parts Distribution Center for handling.

Sold by SEARS, ROEBUCK AND CO., Chicago, IL 60684 U.S.A.

Part No. SP5539

Form No. SP5539

Printed in U.S.A. 10/91

Free Manuals Download Website

<http://myh66.com>

<http://usermanuals.us>

<http://www.somanuals.com>

<http://www.4manuals.cc>

<http://www.manual-lib.com>

<http://www.404manual.com>

<http://www.luxmanual.com>

<http://aubethermostatmanual.com>

Golf course search by state

<http://golfingnear.com>

Email search by domain

<http://emailbydomain.com>

Auto manuals search

<http://auto.somanuals.com>

TV manuals search

<http://tv.somanuals.com>