



SAMSUNG

LCD-Monitor

Chassis LHA20WS

Model 205BW

SERVICE Manual

LCD Monitor

Fashion Feature



- Premium HAS application(Lift 80mm)
- Magic Rotation application
(Auto pivot Delete)
- Embeded Power, Mechanical S/W
application

Copyright

©2006 by Samsung Electronics Co., Ltd.

All rights reserved.

This manual may not, in whole or in part, be copied, photocopied, reproduced, translated, or converted to any electronic or machine readable form without prior written permission of Samsung Electronics Co., Ltd.

LHA20WS Service Manual

First edition March 2006.

Printed in Korea.

Trademarks

Samsung is the registered trademark of Samsung Electronics Co., Ltd.

LHA20WS and MacMaster Cable Adapter are trademarks of Samsung Electronics Co., Ltd.

Macintosh, Power Macintosh are trademarks of Apple Computer, Inc.

All other trademarks are the property of their respective owners.

Contents

1. Precautions	1-1
1-1 Safety Precautions	1-1
1-2 Servicing Precautions	1-2
1-3 Electrostatically Sensitive Devices (ESD) Precautions	1-2
1-4 Installation Precautions	1-3
2. Product specifications	2-1
2-1 Fashion Feature	2-1
2-2 Specifications	2-1
2-3 LS20BRD feature	2-2
2-4 Spec Comparison	2-3
2-5 Option Specification	2-4
3. Alignments and Adjustments	3-1
3-1 Required Equipment	3-1
3-2 Automatic Color Adjustment	3-1
3-3 DDC EDID Data Input	3-1
3-4 Service Function Spec.	3-2
3-5 Hidden Key list	3-3
3-6 EDID Installation with Windows Program	3-4
3-7 Execution Items after replacing the main board	3-4
4. Troubleshooting	4-1
4-1 No Power	4-1
4-2 No Video (PC Analog Signal)	4-3
4-3 No Video (PC Digital Signal)	4-5
5. Exploded View and Parts List	5-1
5-1 LHA20WS Exploded View	5-1
5-2 LHA20WS Parts List	5-2
6. Electrical Parts List	6-1
6-1 LHA20WS Parts List	6-1
7. Block Diagram	7-1

Contents

8. Wiring Diagram	8-1
9. Schematic Diagrams	9-1
9-1 Schematic Diagrams	9-1
9-2 Schematic Diagrams	9-3
10. Operating Instructions and Installation	10-1
10-1 Front	10-1
10-2 Rear	10-2
10-3 Using the Stand	10-4
11. Disassembly and Reassembly	11-1
11-1 Disassembly	11-1
11-2 Reassembly	11-3
12. PCB Diagram	12-1
13. Circuit Descriptions	13-1
13-1 Block description	13-1
13-2 Block operating	13-2
14. Reference Information	14-1
14-1 Technical Terms	14-1
14-2 Pin Assignments	14-4
14-3 Timing Chart	14-5
14-4 Preset Timing Modes	14-6
14-5 Panel Description	14-7



-This Service Manual is a property of Samsung Electronics Co., Ltd.
Any unauthorized use of Manual can be punished under applicable International and/or domestic law.

Samsung Electronics Co.,Ltd.
416, Maetan-3Dong, Yeongtong-Gu, Suwon City,
Gyeonggi-Do, Korea, 443-742
Printed in Korea
P/N : BN82-00136G-00
URL : <http://itself.sec.samsung.co.kr/>

10 Operating Instructions and Installation

10-1 Front



1. Menu button

Opens the OSD menu. Also use to exit the OSD menu or return to the previous menu.

2. MagicBright button

MagicBright is a new feature providing optimum viewing environment depending on the contents of the image you are watching. Currently six different modes are available: Custom, Text, Internet, Game, Sport and Movie. Each mode has its own pre-configured brightness value. You can easily select one of six settings by simply pressing MagicBright control buttons.

1) Custom

Although the values are carefully chosen by our engineers, the pre-configured values may not be comfortable to your eyes depending on your taste. If this is the case, adjust the brightness and contrast by using the OSD menu.

2) Text : Normal brightness

For documentations or works involving heavy text.

3) Internet : Medium brightness

For working with a mixture of images such as text and graphics.

4) Game

For watching motion pictures such as a game.

5) Sport

For watching motion pictures such as a sport.

6) Movie : High brightness

For watching motion pictures such as a DVD or Video CD.

3. Bright button

When OSD is not on the screen, push the button to adjust brightness.

2,3. Adjust buttons

Adjust items in the menu.

4. Enter button / Source button

Activates a highlighted menu item. /

Push the 'SOURCE', then selects the video signal while the OSD is off. (When the source button is pressed to change the input mode, a message appears in the left upper side of the screen displaying the current mode -- analog or digital input signal.)

Note : If you select the digital mode, you must connect your monitor to the graphic card's port using the DVI cable.

5. Auto button

When the 'AUTO' button is pressed, the Auto Adjustment screen appears as shown in the animated screen on the center. Auto adjustment allows the monitor to self-adjust to the incoming video signal. The values of fine, coarse and position are adjusted automatically. (Available in analog mode only)

6. Power button

Use this button for turn the monitor on and off.

10-2 Rear

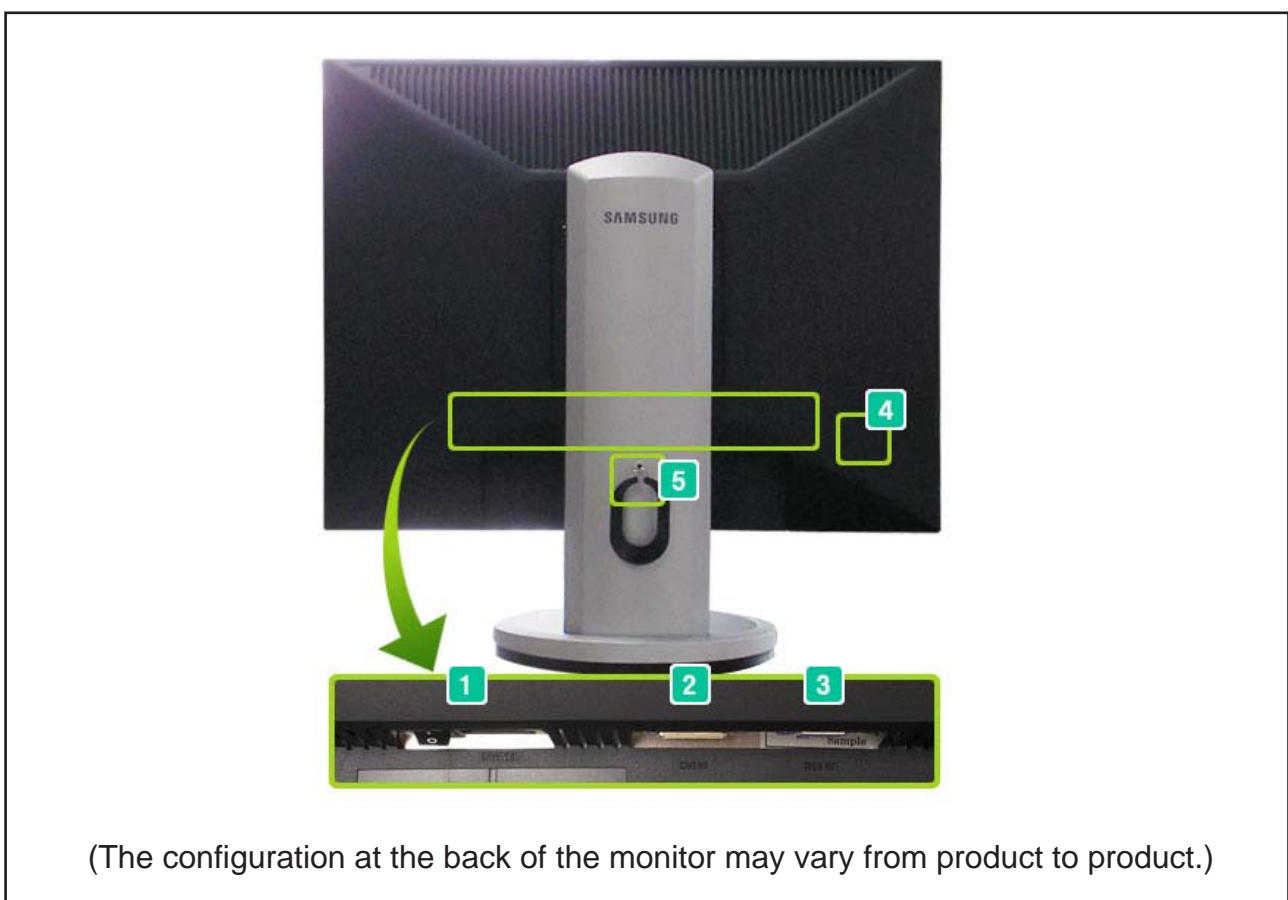

1. **POWER S/W** : Switch the monitor on and off.

2. **POWER IN** : Power cord, plugs into monitor and wall receptacle.



DVI IN port : Connect the DVI Cable to the DVI IN port on the back of your monitor.
(SOURCE : digital)

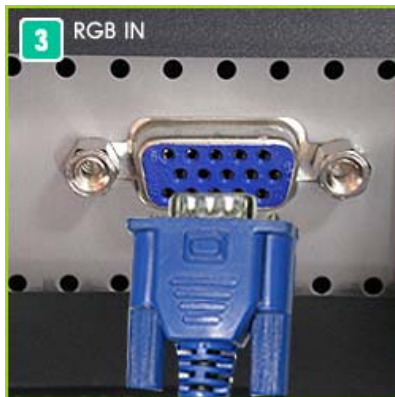

RGB IN port : Connect the signal cable to the RGB IN port on the back of your monitor.
(SOURCE : analog)



Kensington Lock : The Kensington lock is a device used to physically fix the system when using it in a public place.
(The locking device has to be purchased separately.)



Stand Stopper : Remove the fixing pin on the stand to lift the monitor up and down.

10-3 Using the Stand

10-3-1 Removing the base



1. Turn off your monitor and unplug its power cord.
2. Lay the LCD monitor face-down on a flat surface with a cushion beneath it to protect the screen.
3. Remove four screws(A) and then remove the Stand from the LCD monitor.

10-3-2 Attaching a Base

- This monitor accepts a 100mm x 100mm VESA-compliant mounting interface pad.

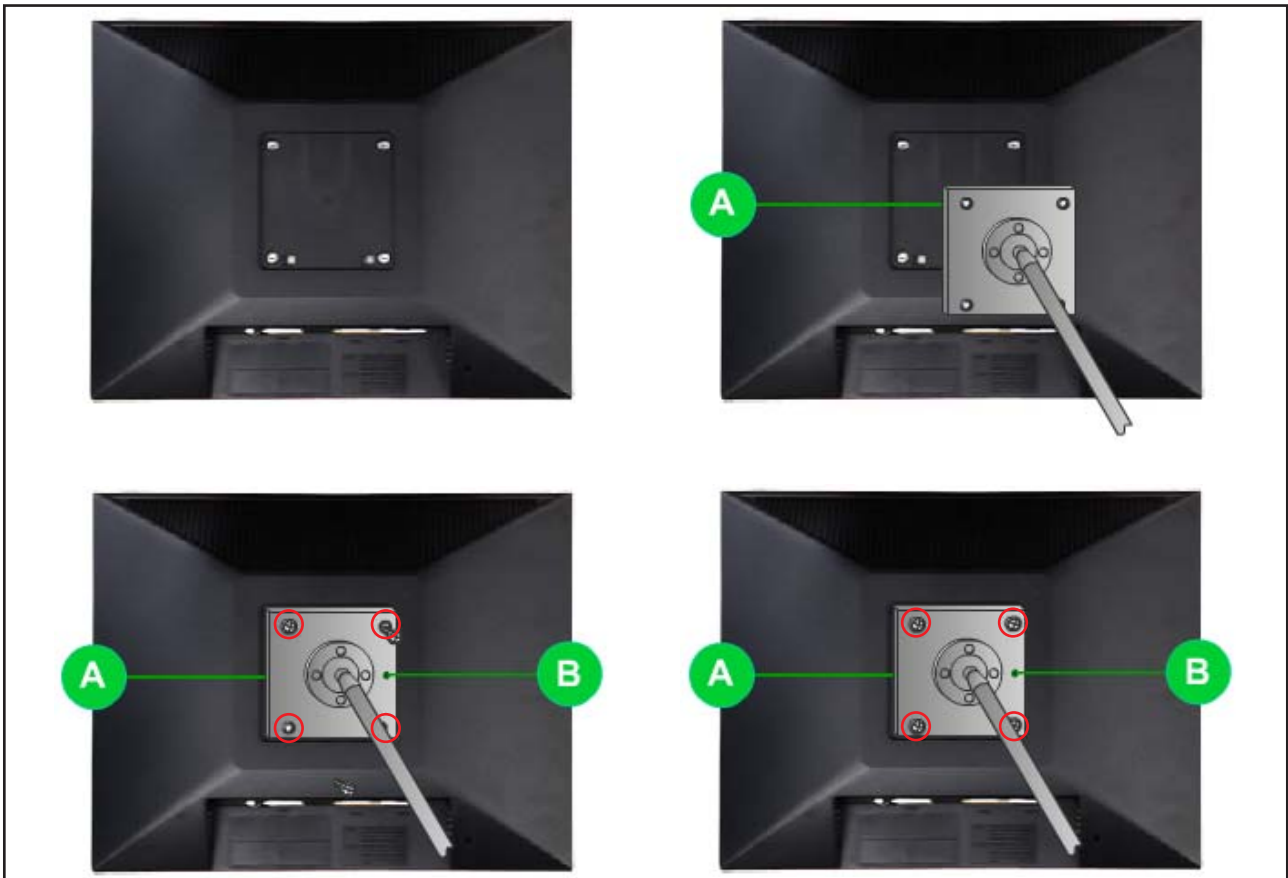

A. Monitor

B. Mounting interface pad

1. Turn off your monitor and unplug its power cord.
2. Lay the LCD monitor face-down on a flat surface with a cushion beneath it to protect the screen.
3. Remove four screws and then remove the stand from the LCD monitor.
4. Align the mounting interface Pad with the holes in the rear cover mounting pad and secure it with four screws that came with the arm-type base, wall mount hanger or other base.

Memo

12 PCB Diagram

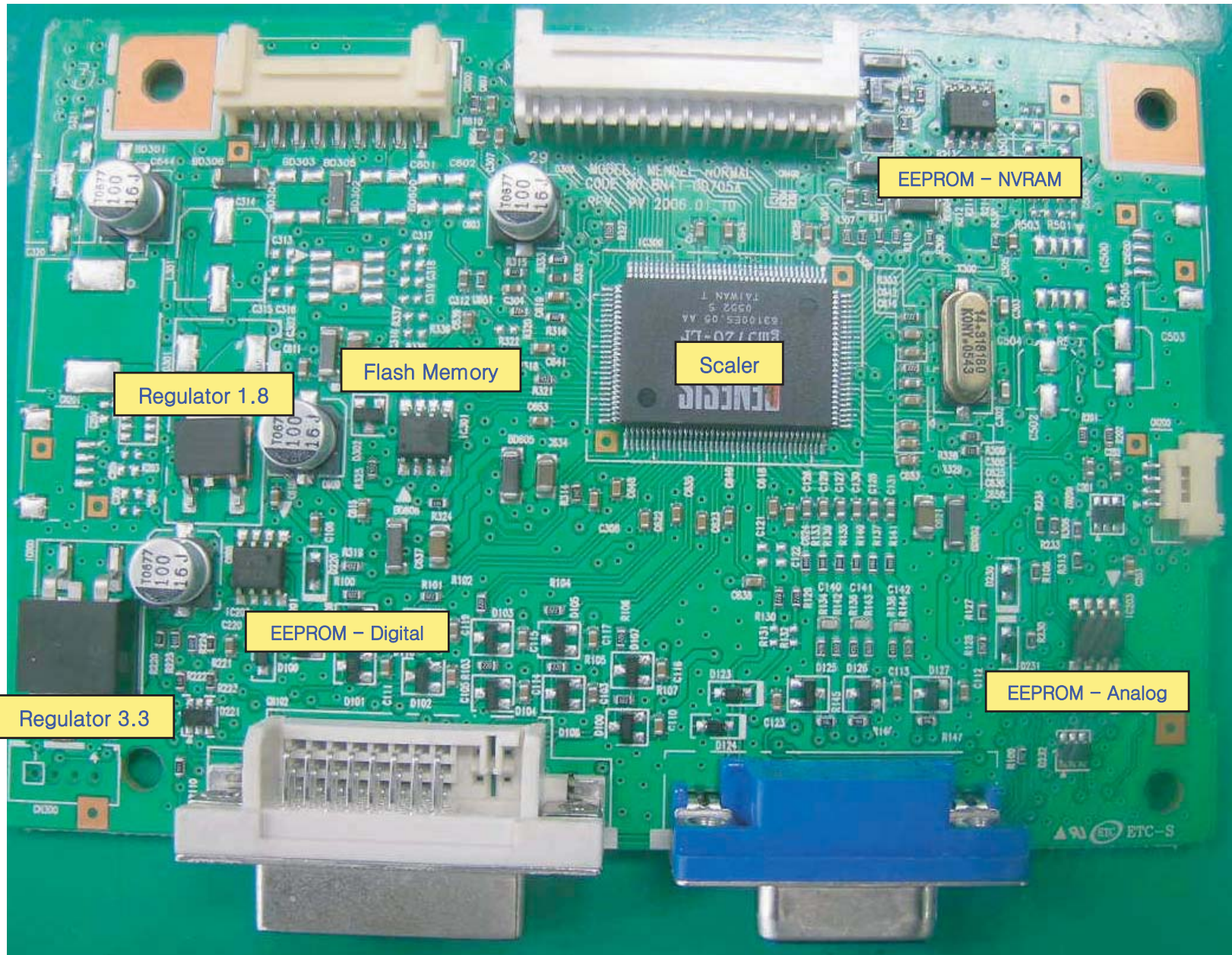

Memo

11 Disassembly and Reassembly

This section of the service manual describes the disassembly and reassembly procedures for the LHA20WS TFT-LCD monitors.

⚠ WARNING: This monitor contains electrostatically sensitive devices. Use caution when handling these components.

11-1 Disassembly

⚠ Cautions:

1. Disassembly stand on the flat desk.
2. Disconnect the monitor from the power source before disassembly.

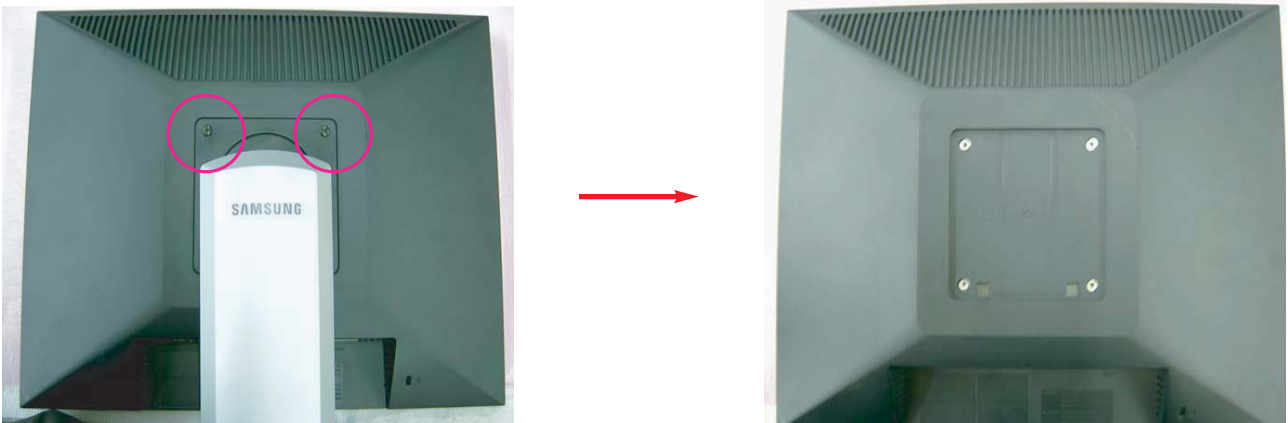

1. Separate the screw. (2 point)

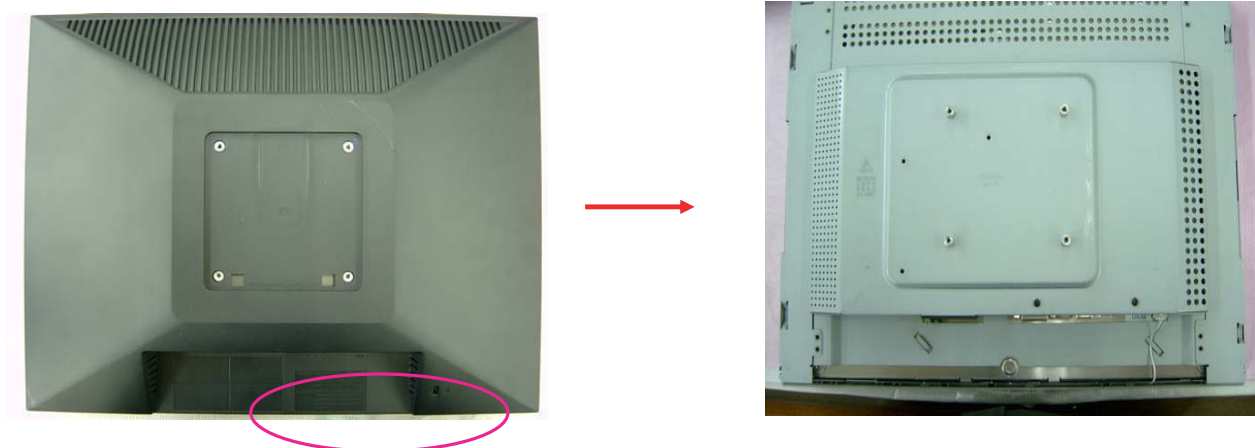

2. Use the Jig and Separate Cover Rear.

11 Disassembly and Reassembly



3. Separate cable Main Board and Separate screw between Shield PCB and Bracket PCB.(2 point)

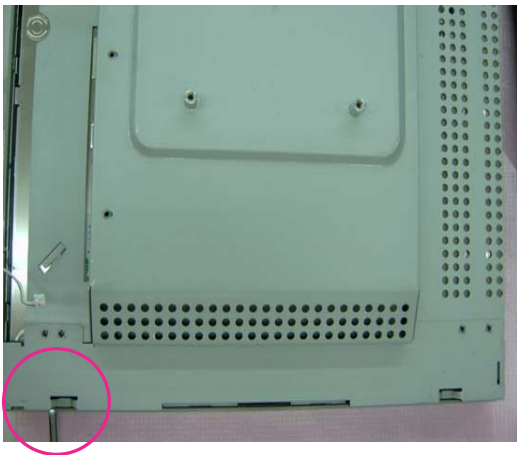

4. Separate screw Between Shield PCB and Panel. (4 point)

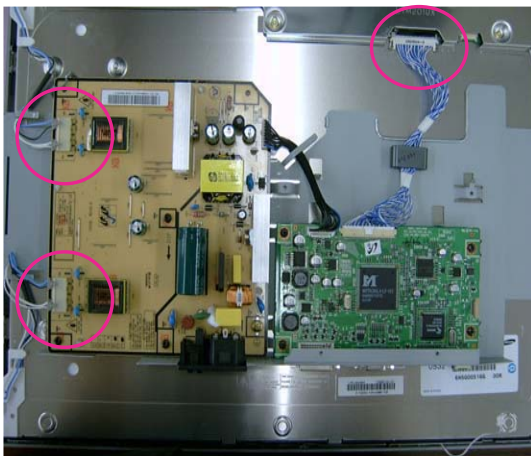

5. Separate harness of the Panel with the IP Board with the Main Board.

11-2 Reassembly

Reassembly procedures are in the reverse order of disassembly procedures.

13 Circuit Descriptions

13-1 Block description

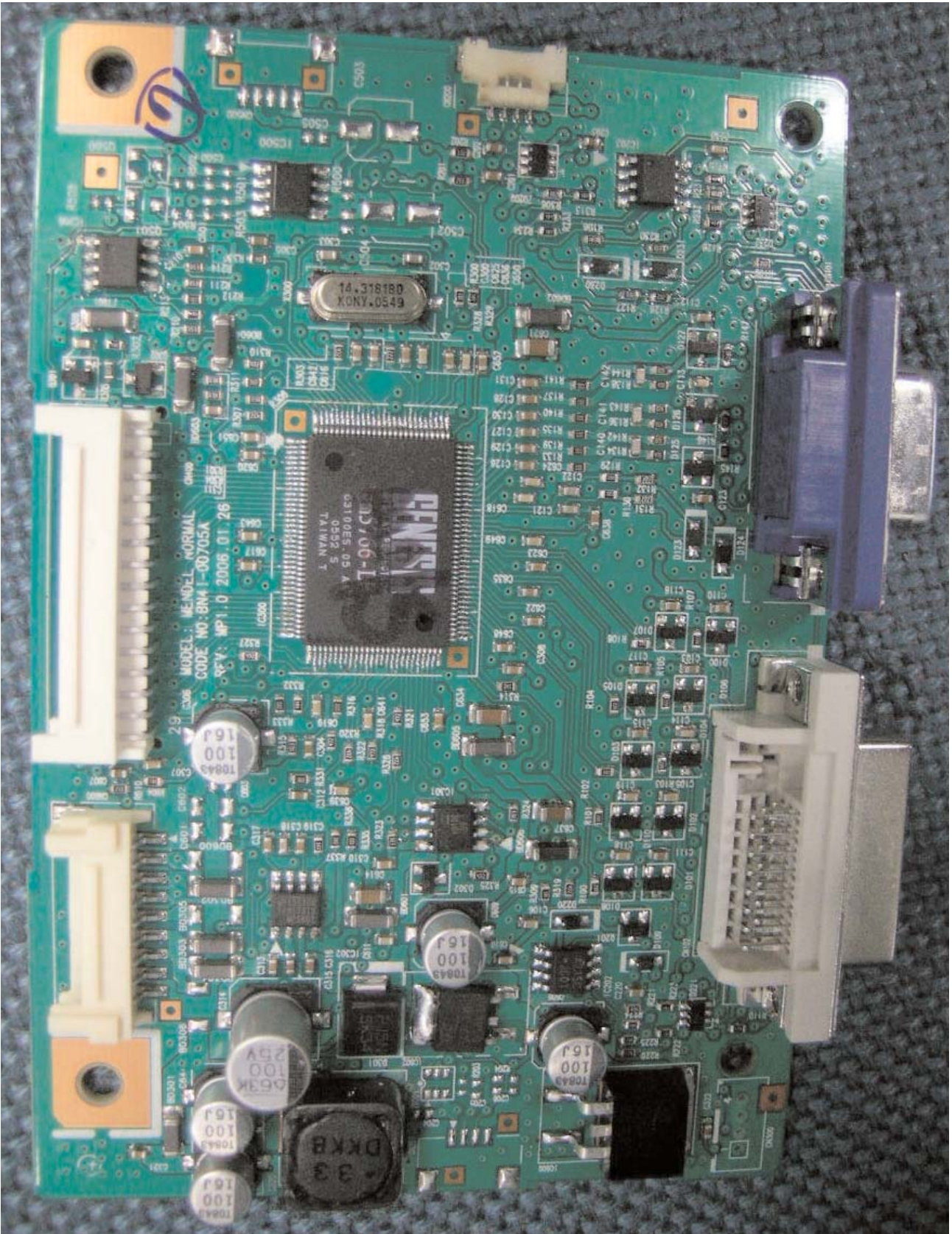

13-2 Block operating

No	Feature	Description
1	Scaler	Scaler Integrate ADC and TMDS, Scaling part.
2	DDR MEMORY	DDR memory Save frame information that SCALER needed .
3	MICOM	Microcontroller. Micom control all function of monitor.

Analog signal from the PC is changed to digital signal using the A/D converter integrated in scaler(MST6281). Scaler scale this digital signal to optimal signal fit to the panel and encode the LVDS signal. This LVDS signal enter the panel to show the image through the LVDS Connector.

In Case of DVI signal, integrated TMDS Block is operating and processing.

Micom control the all function of the monitor and OSD.

DC/DC Block make a suitable voltages from output 14V of I/P board which are used for function of all devices such as scaler, micom, memory, panel

IP board supplies voltages for main board and panel, at the same time, controls the lamp of panel back light.

14 Reference Information

14-1 Technical Terms

- **TFT-LCD**

(Thin film Transistor Liquid Crystal Display)

ADC(Analog to Digital Converter)

This is a circuit that converts from analog signal to digital signals.

- **PLL(Phase Locked Loop)**

During progressing ADC, Device makes clock synchronizing HSYNC with Video clock

- **Inverter**

Device that supplies Power to LCD panel lamp. This device generates about 1,500~2,000V.

- **SMPS(Switching Mode Power Supply)**

Switching Mode Power supply. This design technology is used to step up/down the input power by switching on/off

- **FRC(Frame Rate Controller)**

Technology that change image frame quantity displayed on screen for one second.

Actually TFT-LCD panel require 60 pcs of frame for one second.

so,this technology is needed to convert input image to 60 pcs regardless input frame quantity.

- **Image Scaler**

Technology that convert various input resolution to other resolution.(ex. 640* 480 to 1024*768)

- **Auto Configuration(Auto adjustment)**

This is an algorithm to adjust monitor to optimum condition by pushing one key.

- **OSD(On Screen Display)**

On screen display. customer can control the screen easily with this.

- **Image Lock**

This means "Fineness adjustment" in LCD Monitor, the features are "Fine" and "Coarse"

- **FINE**

"Fine" adjustment is used to adjust visibility by control phase difference.

- **COARSE**

This is a adjustment by tuning with Video colck and PLL clock.

- **DVI (Digital Visual Interface)**

This provides a high speed digital connection for visual data types that is display technology independent. this interface is primarily focused at providing a connection between a computer and its display device.

- **L.V.D.S.(Low Voltage Differential Signaling)**

a kind of transmission method for Digital. It can be used from Main PBA to Panel.

- **DVI (Digital Visual Interface)**

This provides a high speed digital connection for visual data types that is display technology independent. this interface is primarily focused at providing a connection between a computer and its display device.

- **T.M.D.S**

(Transition minimized Differential Signaling)

a kind of transmission method for Digital. It can be used from Video card to Main PBA.

- **DDC(Display data channel)**

It is a communication method between Host Computer and related equipment. It can make it Plug and Play between PC and Monitor.

- **EDID**

Extended Display Identification Data PC can recognize the monitor information as Product data, Product name,Display mode,Serial number and Signal source,etc through DDC Line communicating with PC and Monitor.

- Dot Pitch

The image on a monitor is composed of red, green and blue dots. The closer the dots, the higher the resolution. The distance between two dots of the same color is called the 'Dot Pitch'. Unit: mm

- Vertical Frequency

The screen must be redrawn several times per second in order to create and display an image for the user. The frequency of this repetition per second is called Vertical Frequency or Refresh Rate. Unit: Hz

Example: If the same light repeats itself 60 times per second, this is regarded as 60 Hz.

- Horizontal Frequency

The time to scan one line connecting the right edge to the left edge of the screen horizontally is called Horizontal Cycle. The inverse number of the Horizontal Cycle is called Horizontal Frequency. Unit: kHz

- Interlace and Non-Interlace Methods

Showing the horizontal lines of the screen from the top to the bottom in order is called the Non-Interlace method while showing odd lines and then even lines in turn is called the Interlace method. The Non-Interlace method is used for the majority of monitors to ensure a clear image. The Interlace method is the same as that used in TVs.

- Plug & Play

This is a function that provides the best quality screen for the user by allowing the computer and the monitor to exchange information automatically. This monitor follows the international standard VESA DDC for the Plug & Play function.

- Resolution

The number of horizontal and vertical dots used to compose the screen image is called 'resolution'. This number shows the accuracy of the display. High resolution is good for performing multiple tasks as more image information can be shown on the screen.

Example: If the resolution is 1280 x 1024 , this means the screen is composed of 1280 horizontal dots (horizontal resolution) and 1024 vertical lines (vertical resolution).

- S-Video

Short for "Super Video." S-Video allows up to 800 lines of horizontal resolution, enabling high-quality video.

- External Device Input

External device input refers to video input from such external video devices as VCRs, camcorders and DVD players, separate from a TV broadcast.

- DVD

A type of digital disk technology that takes up only the benefits of CD and LD, to implement a high resolution/quality, which enables the user to enjoy clearer images.

- Connecting the Monitor

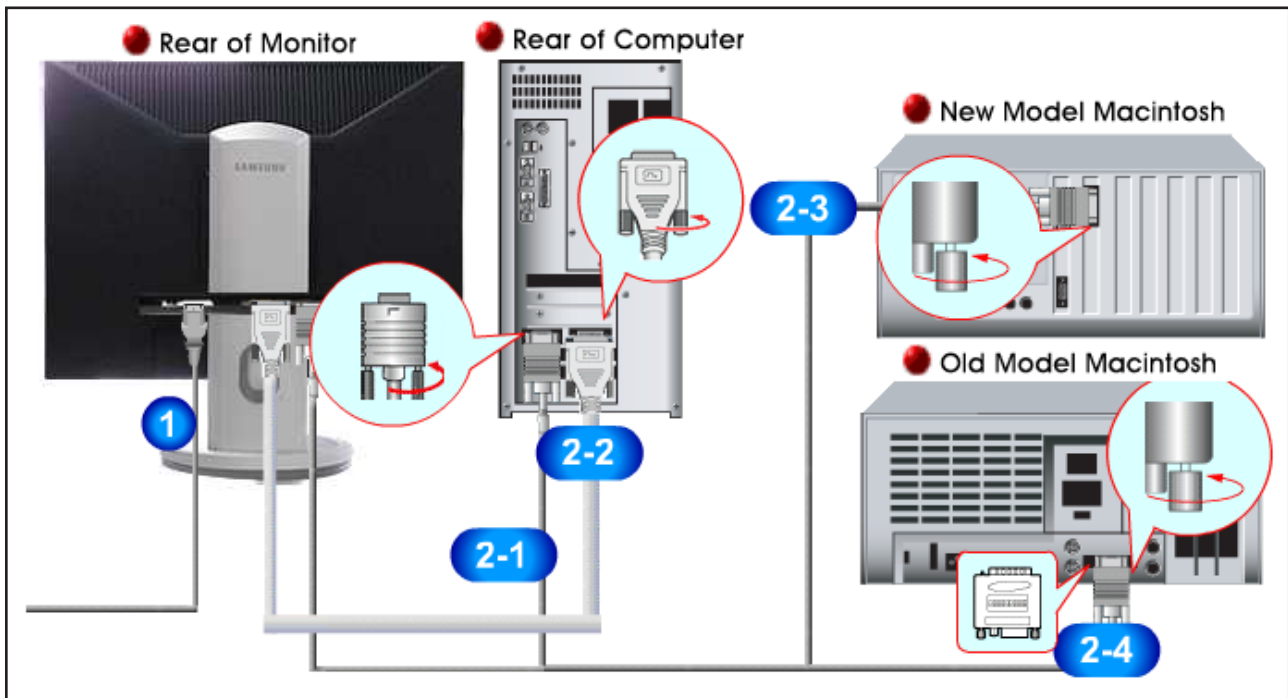

1. Connect the DC adapter for your monitor to the power port on the back of the monitor. Plug the power cord for the monitor into a nearby outlet.
- 2-1. Using the D-sub (Analog) connector on the video card. Connect the signal cable to the 15-pin, D-sub connector on the back of your monitor.



- 2-2. Using the DVI (Digital) connector on the video card. Connect the DVI cable to the DVI port on the back of your monitor.



- 2-3. Connected to a Macintosh. Connect the monitor to the Macintosh computer using the D-SUB connection cable.
- 2-4. In the case of an old model Macintosh, you need to connect the monitor using a special Mac adapter.
3. Turn on your computer and monitor. If your monitor displays an image, installation is complete.

- You may get a blank screen depending on the type of video card you are using, if you connect simultaneously both the D-Sub and DVI cables to one computer.

- If you properly connect your monitor using the DVI connector but get a blank screen, check to see if the monitor status is set to analog. Press power button to have the monitor double-check the input signal source.

14-2 Pin Assignments

Pin No.	Sync Type	15-Pin D-Sub Signal Cable Connector		
		Separate	Composite	Sync-on-green
1		Red	Red	Red
2		Green	Green	Green + H/V Sync.
3		Blue	Blue	Blue
4		GND	GND	GND
5		DDC Return (GND)	DDC Return (GND)	DDC Return (GND)
6		GND-R	GND-R	GND-R
7		GND-G	GND-G	GND-G
8		GND-B	GND-B	GND-B
9		DDC Power Input (+5V)	DDC Power Input (+5V)	DDC Power Input (+5V)
10		Self Raster	Self Raster	Self Raster
11		GND	GND	GND
12		Bi-Dr Data (SDA)	Bi-Dr Data (SDA)	Bi-Dr Data (SDA)
13		H-Sync.	H/V-Sync.	Not Used
14		V-Sync.	Not Used	Not Used
15		DDC Clock (SCL)	DDC Clock (SCL)	DDC Clock (SCL)

Pin No.	Sync Type	24P DVI-D		
1		Rx2-	13	No Connection
2		Rx2+	14	+5V_M
3		GND	15	Self Raster
4		No Connection	16	+5V_M
5		No Connection	17	Rx0-
6		DDC Clock (SCL)	18	Rx0+
7		DDC Data (SDA)	19	NC
8		NC	20	No Connection
9		Rx1-	21	No Connection
10		Rx1+	22	NC
11		NC	23	RxC+
12		No Connection	24	RxC-

14-3 Timing Chart

- This section of the service manual describes the timing that the computer industry recognizes as standard for computer-generated video signals.

Table 14-1 Timing Chart

Mode Timing	IBM		VESA						
	VGA2/ 70 Hz 720 x 400	VGA3/ 60 Hz 640 x 480	640/75 Hz 640x480	800/60 Hz 800x600	800/75 Hz 800x600	1024/60 Hz 1024x768	1024/75 Hz 1024x768	1280/60 Hz 1280x1024	1280/75 Hz 1280x1024
fH (kHz)	31.469	31.469	37.500	37.879	46.875	48.363	60.023	63.981	79.975
A μsec	31.777	31.778	26.667	26.400	21.333	20.677	16.660	11.852	12.504
B μsec	3.813	3.813	2.032	3.200	1.616	2.092	1.219	1.037	1.067
C μsec	1.589	1.589	3.810	2.200	3.232	2.462	2.235	2.296	1.837
D μsec	26.058	26.058	20.317	20.000	16.162	15.754	13.003	9.259	9.481
E μsec	0.318	0.318	0.508	0.000	0.323	0.369	0.203	0.000	0.119
fV (Hz)	70.087	59.940	75.000	60.317	75.000	60.004	75.029	60.020	75.025
O msec	14.268	16.683	13.333	16.579	13.333	16.666	13.328	16.005	13.329
P msec	0.064	0.064	0.080	0.106	0.064	0.124	0.050	0.047	0.038
Q msec	0.858	0.794	0.427	0.607	0.448	0.600	0.466	0.594	0.475
R msec	13.155	15.761	12.800	15.840	12.800	15.880	12.795	15.630	12.804
S msec	0.191	0.064	0.027	0.0261	0.021	0.062	0.017	0.016	0.013
Clock Freq. (MHz)	28.322	26.175	31.500	40.000	49.500	75.000	78.750	108.000	135.000
Polarity H.Sync	Negative	Negative	Negative	Positive	Positive	Negative	Positive	Positive	Positive
V.Sync	Positive	Negative	Negative	Positive	Positive	Negative	Positive	Positive	Positive
Remark	Separate	Separate	Separate	Separate	Separate	Separate	Separate	Separate	Separate

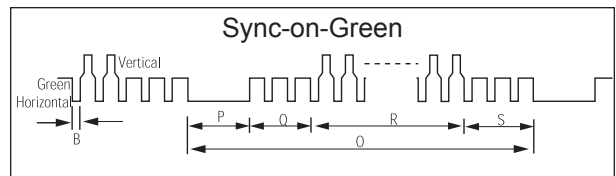
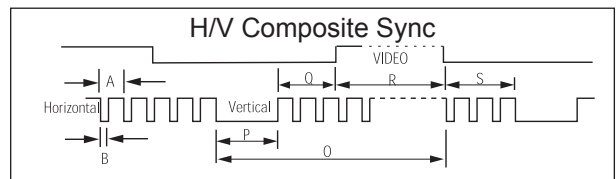
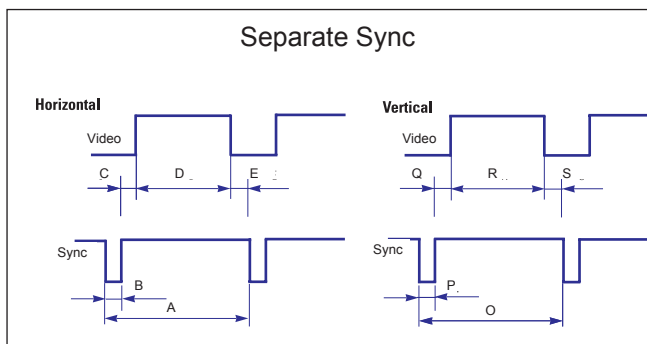

A : Line time total
 B : Horizontal sync width
 C : Back porch
 D : Active time
 E : Front porch

O : Frame time total
 P : Vertical sync width
 Q : Back porch
 R : Active time
 S : Front porch

14-4 Preset Timing Modes

- If the signal transferred from the computer is the same as the following Preset Timing Modes, the screen will be adjusted automatically. However, if the signal differs, the screen may go blank while the power LED is on. Refer to the video card manual and adjust the screen as follows.

Table 1. Preset Timing

Display Mode	Horizontal Frequency (kHz)	Vertical Frequency (Hz)	Pixel Clock (MHz)	Sync Polarity (H/V)
MAC, 640 x 480	35.000	66.667	30.240	-/-
MAC, 832 x 624	49.726	74.551	57.284	-/-
IBM, 640 x 350	31.469	70.086	25.175	+/-
IBM, 640 x 480	31.469	59.940	25.175	-/-
IBM, 720 x 400	31.469	70.087	28.322	-/+
VESA, 640 x 480	37.500	75.000	31.500	-/-
VESA, 640 x 480	37.861	72.809	31.500	-/-
VESA, 800 x 600	35.156	56.250	36.000	+,-/+,-
VESA, 800 x 600	37.879	60.317	40.000	+/+
VESA, 800 x 600	46.875	75.000	49.500	+/+
VESA, 800 x 600	48.077	72.188	50.000	+/+
VESA, 1024 x 768	48.363	60.004	65.000	-/-
VESA, 1024 x 768	56.476	70.069	75.000	-/-
VESA, 1024 x 768	60.023	75.029	78.750	+/+
VESA, 1280 x 1024	63.981	60.020	108.00	+/+
VESA, 1280 x 1024	79,976	75,025	135,00	+/+
VESA, 1600 x 1200	75.000	60.000	162.00	+/+

Horizontal Frequency

The time to scan one line connecting the right edge to the left edge of the screen horizontally is called Horizontal Cycle and the inverse number of the Horizontal Cycle is called Horizontal Frequency. Unit: kHz

Vertical Frequency

Like a fluorescent lamp, the screen has to repeat the same image many times per second to display an image to the user. The frequency of this repetition is called Vertical Frequency or Refresh Rate. Unit: Hz

14-5 Panel Description

Maker	VENDOR P/N	PANEL_CODE	PANEL_ABB	STICKER_CODE	Remarks
SEC	LT140X1-002	BN07-00004A	SA	BN68-00239H	-
SEC	LT150XS-L01	BN07-00009A	SB		-
SEC	LT150XS-L01-B	BN07-00022A	SC		-
SEC	LTM150XS-L02	BN07-00005A	SD		-
SEC	LT181E2-132	BN07-00001A	SE		-
SEC	LT150XS-T01	BN07-00010A	SF		-
SEC	LTM181E3-132	BN07-00019A	SG		-
SEC	LT170E2-131	BN07-10001D	SH		-
SEC	LT181E2-131	BN07-10001E	SJ		-
SEC	LTM170E4-L01	BN07-00018A	SK		-
SEC	LTM240W1-L01	BN07-00015A	SL		-
SEC	LTM213U3-L01	BN07-00016A	SM		-
SEC	LTM150XH-L01	BN07-00026A	SN		-
SEC	LTM150XH-L03	BN07-00027A	SP		-
SEC	LTM150XS-L01	BN07-00032A	SQ		DELL(ZPD)
SEC	LTM181E4-L01	BN07-00034A	SR		PVA
SEC	LTM170EH-L01	BN07-00036A	SS		TN
SEC	LTM170E5-L01	BN07-00037A	SU		PVA
SEC	LTM150XH-L11	BN07-00041A	SV		-
SEC	LTM213U4-L01	BN07-00039A	SW		PVA
SEC	LTM150XH-L01(ZPD)	BN07-00045A	SX		ZPD
SEC	LTM150XH-L04	BN07-00046A	SY		New panel with high brightness
SEC	LTM170W1-L01	BN07-00047A	SZ		Panel for TV
SEC	LTM150XH-L06	BN07-00053A	EA		Panel for TV High luminance for 450cd _ SONY&EOS Team Panel for TV
SEC	LTM153W1-L01	BN07-00054A	EB		Use NIKE MODEL
SEC	LTM170EH-L05	BN07-00055A	EC		Panel EOS proj. for high brightness of 17" EH-L05
SEC	LTM170E5-L03	BN07-00056A	ED		Dell 1702FP pro. E4. EH mechanical Compatible
SEC	LTM190E1-L01	BN07-00057A	EE		DELL 1900 FP
SEC	LTM181E5-L01	BN07-00061A	EF		18" narrow bezel GH18PS
SEC	LTM150XP-L01	BN07-00065A	EG		AMLCD PVA PANEL
SEC	LTM240W1-L02	BN07-00062A	EH		Panel for 15" Wide TV
SEC	LTM170EU-L01	BN07-00071A	EJ		Slim design, TN
SEC	LTM170E5-L04	BN07-00072A	EK		E5-L04 6 bits FRC... for IBM
SEC	LTA220W1-L01	BN07-00074A	EL		Panel for 22" TV
SEC	LTM170E6-L02	BN07-00075A	EM		AMLCD Narrow & slim design 17" PVA mode
SEC	LTM170W1-L01	BN07-00082A	EN		LTM170W1-L01 ZPD panel
SEC	LTM170EH-L01	BN07-00080A	EP		LTM170EH-L01 ZPD panel
SEC	LTM170E5-L01	BN07-00081A	EQ		LTM170E5-L01 ZPD panel
SEC	LTM170EH-L05	BN07-00083A	ER		LTM170EH-L05 ZPD panel
SEC	LTM170E5-L03	BN07-00084A	ES		LTM170E5-L03 ZPD panel
SEC	LTM170EU-L01	BN07-00085A	ET		LTM170EU-L01 ZPD panel
SEC	LTM170E5-L04	BN07-00086A	EU		LTM170E5-L04 ZPD panel
SEC	LTM170E6-L02	BN07-00087A	EV		LTM170E6-L02 ZPD panel
SEC	LTM150XH-L06	BN07-00091A	EW		Color coordinates change for LCD TV
SEC	LTM153W1-L01	BN07-00092A	EX		AMLCD WIDE 15" 9/10
SEC	LTM170W1-L01	BN07-00100A	EY		Color Coordinates change code management
SEC	LTM170EH-L05	BN07-00097A	EZ		LTM170E5-L05 Color Coordinates Change Panel Code
SEC	LTA400W1-L01	BN07-00109A	S1		PANEL of AMLCD 40" TV
SEC	LTM153W1-L01	BN07-00110A	S2		Color coordinates change 0.280/0.290, 10000k & ZPD Panel
SEC	LTM150XH-L06	BN07-00111A	S3		Color coordinates change 0.280/0.290, 10000k & ZPD Panel
SEC	LTM170W1-L01	BN07-00112A	S4		Color coordinates change 0.280/0.290, 10000k & ZPD Panel
SEC	LTM170EH-L05	BN07-00113A	S5		Color coordinates change 0.280/0.290, 10000k & ZPD Panel
SEC	LTM220W1-L01	BN07-00114A	S6		ZPD Panel for AMLCD 22" TV
SEC	LTM150XH-L06	BN07-00117A	S7		ZPD Panel code
SEC	LTM153W1-L01	BN07-00118A	S8		ZPD Panel code
SEC	LTM170WP-L01	BN07-00119A	S9		PVA Panel for NIKE
SEC	LTM213U4-L01	BN07-00039A	E1		21.3" NARROW
SEC	LTA260W1-L01	BN07-00121A	E2		VENUS
SEC	LTA220W1-L01	BN07-00074B	E3		"Panel B-level panel code for 22" TV Panel"
SEC	LTA320W1-L01	BN07-00108A	E4		"Panel for AMLCD 32" TV"
SEC	LTM213U4-L01	BN07-00124A	E5		NARROW BEZEL 21" PANEL
SEC	LTM170E6-L04	BN07-00129A	E6		"HIGHLAND 17" LOW PANEL (Panel only for TCO03)"
SEC	LTM190E1-L01	BN07-00088A	E7		LTM190E1-L01 ZPD panel
SEC	M150X4-L06	BN07-00137A	E8		15" Narrow & Slim panel
SEC	LTA170V1	BN07-00139A	E9		"17" Panel for Muse 4:3 VGA TV"
SEC	LTM190E1-L02	BN07-00128A	E10		"New Panel from AMLCD, Specification : 6bit Driver IC"
SEC	LTM170EX-L01	BN07-00143A	E11		"Development new Panel from AMLCD"
SEC	LTM170E8-L01	BN07-00144A	E12		"Development new Panel from AMLCD"
SEC	LTM170E6-L04	BN07-00129B	E13		"ZPD panel for AMLCD (Panel only for TCO03)"
SEC	LTA320W1-L02	BN07-00108B	E14		"Creat B-level Panel code for AMLCD 32" TV"
SEC	LTM190E1-L03	BN07-00151A	E15		"Development new 19" Panel from AMLCD (Panel only for TCO03)"
SEC	LTM240W1-L03	BN07-00134A	E16		"AMLCD 24" panel development"
SEC	LTM190E1-L02	BN07-00128B	E17		"New Panel from AMLCD, Specification : 6bit Driver IC(ZPD)"
SEC	LTM190E4-L01	BN07-00145A	E18		"AMLCD 24" new panel development"
SEC	LTM170E8-L01	BN07-00158A	E19		"ZPD code derivation"
SEC	LTM170EX-L01	BN07-00159A	E20		"ZPD code derivation"
SEC	LTM190E1-L03	BN07-00151B	E21		"Creat new panel code for AMLCD 19" (Panel only for TCO03)"

14 Reference Infomation

Maker	VENDOR P/N	PANEL_CODE	PANEL_ABB	STICKER_CODE	Remarks
SEC	LTA460H1-L01	BN07-00157A	E22		*creat panel code for AMLCD 46" TV *
SEC	LTM170EU-L11	BN07-00160A	E23		*creat new panel code for AMLCD 17" (Panel only for TCO03)
SEC	LTM240W1-L03	BN07-00134B	E24		"24" panel ZPD code derivation"
SEC	LTM190E4-L01	BN07-00145B	E25		"AMLCD 19" ZPD Panel code derivation"
SEC	LTM240W1-L03	BN07-00134B	E26		"24" panel ZPD code derivation"
SEC	LTM150XO-L01	BN07-00164A	E27		"AMLCD 15" XO-L01 new panel development"
SEC	LTM150XO-L01	BN07-00164B	E28		"AMLCD 15" XO-L01 ZPD code derivation"
SEC	LTM170EU-L11	BN07-00160B	E29		"AMLCD 17" NEW panel code derivation"
SEC	LTA320W2-L01	BN07-00172A	SPZ		AMLCD 32" NEW panel
SEC	LTM213U4-L01	BN07-00124B	SPZ		21.3" Narrow PANEL ZPD Panel derivation
SEC	LTM170EU-L11	BN07-00189A	STH		AMLCD EU-L11 Pb free panel code derivation
SEC	LTM170EU-L11	BN07-00189B	STZ		AMLCD EU-L11 Pb free panel ZPD code derivation
SEC	LTM240W1-L04	BN07-00188A	SPH		24" A-DCC new panel development
SEC	LTM240W1-L04	BN07-00188B	SPZ		24" A-DCC panel ZPD code derivation
SEC	LTM190EX-L01	BN07-00191A	STH		AMLCD 19" TN new Panel
SEC	LTM190EX-L02	BN07-00191B	STZ		AMLCD 19" TN new Panel ZPD derivation
SEC	LTA230W1-L02	BN07-00184A	SPZ		AMLCD 23" 16:9 new Panel
SEC	LTA260W2-L01	BN07-00185A	SPZ		AMLCD 26" 16:9 new Panel
SEC	LTM240M1-L01	BN07-00195A	SPH		24" panel with high brightness development
SEC	LTA400W2-L01	BN07-00186A	SPZ		AMLCD 40" 16:9 new Panel
SEC	LTM150XO-L01	BN07-00197A	STH		AMLCD 15" XO-L01 Pb free panel code
SEC	LTM150XO-L01	BN07-00197B	STZ		AMLCD 15" XO-L01 Pb free panel ZPD code
SEC	LTM170EU-L21	BN07-00202A	STZ		AMLCD EU-L21 ZPD new code derivation
SEC	LTA460W2-L03	BN07-00187A	SPZ		BEETOVEN 46"ZPD new panel
SEC	LTM240M1-L01	BN07-00195B	SPZ		24" igh brightness panel ZPD code derivation
SEC	M170EX-L21	BN07-00206A	STZ		AMLCD LTM170EX-L21 ZPD new code derivation
SEC	LTA460H3-L01	BN07-00200A	SPZ		AMLCD 46" LED BLU panel
SEC	LTM170EU-L15	BN07-00214A	STZ		AMLCD EU-L15 TV high brightness ZPD new code derivation
SEC	LTM170E8-L21	BN07-00218A	SPZ		AMLCD LTM170E8-L21 PVA ZPD new code derivation
SEC	LTM190EX-L21	BN07-00222A	STZ		DISPLAY LCD
SEC	LTM201U1-L01	BN07-00190B	SPZ		AMLCD 20.1" Normal panel ZPD code derivation
SEC	LTM190E4-L21	BN07-00223A	SPZ		HAYDN 17" PZD code PANEL derivation
SEC	LTA570H1-L01	BN07-00196A	SPZ		AMLCD 57" new panel development
SEC	LTM150XO-L21	BN07-00229A	STZ		AMLCD 15" XO-L21 8ms panel code
SEC	LTA260W2-L11	BN07-00239A	SPZ		AMLCD 26" 16:9 7Line new Panel
SEC	LTA400WS-LH1	BN07-00245A	SPZ		AMLCD 40" 16:9 SPVA 90% new Panel
SEC	LTM213U6-L01	BN07-00231A	SPZ		AMLCD 21.3" PVA new Panel Code
SEC	LTA320WS-LH2	BN07-00244A	SPZ		AMLCD 32" 16:9 SPVA 90% new Panel
SEC	LTA400WS-LH1	BN07-00245A	SPZ		AMLCD 40" 16:9 SPVA 90% new Panel
CPT	CLAA150XG09	BN07-00141A	PA		"CPT 15" Monitor new panel development"
CPT	CLAA170EA02	BN07-00148A	PB		"17" CPT NEW development panel"
CPT	CLAA170EA02	BN07-00148B	PC		"17" CPT ZPD panel code derivation"
CPT	CLAA150XG09	BN07-00141B	PTZ		"CPT 15" panel ZPD code derivation (GOYA-PJT)"
CPT	CLAA150XP01	BN07-00173A	PTH		CPT 15" PSWG code derivation
CPT	CLAA150XP01	BN07-00173B	PTZ		CPT 15" PSWG panel ZPD code
CPT	CLAA170EA07	BN07-00174A	PTH		"CPT 17" PSWG panel code derivation
CPT	CLAA170EA07	BN07-00174B	PTZ		CPT 17" PSWG type new Panel code"
CPT	CLAA170EA07	BN07-00174B	PTZ		CPT 17" PSWG type new Panel code
CPT	CLAA170EA07Q	BN07-00220A	PTZ		CPT 17" PSWG R/T 8mscc code derivation
CPT	CLAA170EA07Q	BN07-00220B	PTH		CPT 17" PSWG R/T 8mscc HPD code derivation
CPT	CLAA150XP01F	BN07-00236A	PTZ		CPT 15" PSWG panel ZPD & Lead free code derivation
TOSHIBA	LTM15C419(A)	BN07-00002A	TA		-
TOSHIBA	LTM15C423(B)	BN07-00006A	TB		-
TOSHIBA	LTM18C161	BN07-00008A	TC		-
TOSHIBA	LTM15C443	BN07-00031A	TD		-
TOSHIBA	LTM15C458	BN07-00043A	TE		-
TOSHIBA	LTM15C458S	BN07-00077A	TF		"TSB 15" high brightness Panel"
TOSHIBA	LTM15C458	BN07-00078A	TG		Toshiba ZPD panel
TOSHIBA	LTM15C458S	BN07-00099A	TH		TSB LTM15C458S (ZPD)
HANNSTAR	HSD150MX41A(A)	BN07-00020A	NA		"TTL type"
HANNSTAR	HSD150MX12	BN07-00030A	NB		"TTL type"
HANNSTAR	HSD170ME13	BN07-00180A	NTH		Hannstar 17" TN new panel development
HANNSTAR	HSD170ME13	BN07-00180B	NTZ		Hannstar 17" TN new panel development ZPD code derivation
HANNSTAR	HSD190ME12	BN07-00210A	NTZ		Hannstar 19" TN new panel development
HANNSTAR	HSD150MX17-A	BN07-00226A	NTZ		Hannstar 15" slim panel ZPD code derivation
TORISAN	TM150XG-22L03(A)	BN07-00021A	RA		-
TORISAN	TM150XG-26L06	BN07-00042A	RB		-
TORISAN	TM181SX-76N01	BN07-00048A	RC		-
TORISAN	TM150XG-26L06	BN07-00059A	RD		15" XGA TN MODE(ZPD)
TORISAN	TM290WX-71N31	BN07-00063A	RE		"RS24NS (TORISAN 29" NEW PANEL)"
TORISAN	TM396WX-71N31	BN07-00064A	RF		"RS24NS (TORISAN 40" NEW PANEL)"
TORISAN	TM150XG-26L09	BN07-00073A	RG		"Panel for 15" TV"
TORISAN	TM150XG-26L10	BN07-00089A	RH		"L10(change except D/C) ZPD"
TORISAN	TM150XG-26L10	BN07-00090A	RJ		L10 NORMAL
TORISAN	TM190SX-70N01	BN07-00098A	RK		Torisan 19" Panel
TORISAN	TM181SX-76N01	BN07-00106A	RL		ZPD Panel code
TORISAN	TM190SX-70N01	BN07-00107A	RM		ZPD Panel code

Maker	VENDOR P/N	PANEL_CODE	PANEL_ABB	STICKER_CODE	Remarks
TORISAN	TM290WX-71N31	BN07-00115A	RN		*Color Coordinates change panel for TORISAN 29" TV"
TORISAN	TM396WX-71N31	BN07-00116A	RP,Q		*Color Coordinates change panel for TORISAN 40" TV"
TORISAN	TM220WX-71N31	BN07-00125A	RR		*Development TORISAN 22" TV PANEL (ZPD)
TORISAN	TM220WX-71N31	BN07-00127A	RS		*Development TORISAN 22" TV PANEL (HPD)
TORISAN	TM396WX-71N32A	BN07-00150A	RT		120V inverter Exclusive panel
TORISAN	TM190SX-70N02	BN07-00154A	RMH		Torisan 8bit panel code Derivation
TORISAN	TM190SX-70N02	BN07-00154B	RMZ		Torisan 8bit panel code Derivation
TORISAN	TM150XG-A01	BN07-00162A	RTH		Torisan 15" Narrow & Slim panel development
TORISAN	TM150XG-A01	BN07-00162B	RTZ		Torisan 15" N&S panel ZPD code Derivation
SHARP	LQ181E1DG11(A)	BN07-10001C	PA		-
SHARP	LQ150X1LW71	BN07-00067A	PB		SHARP 15" PVA PANEL
SHARP	LQ370T3LZ41	BN07-00216A	FAZ		Rome2
HITACHI	TX38D12VCOCAA(A)	BN07-00003A	HA		-
HITACHI	TX43D1VCOCCAB	BN07-00060A	HB		17" SXGA PVA MODE
HITACHI	TX43D15VCOCCAB	BN07-00101A	HC		ZPD Panel
HITACHI	TX51D11VCOCCAB	BN07-00122A	HD		20.1" NARROW
HITACHI	TX54D11VCOCCAB	BN07-00123A	HE		21.3" NARROW
HITACHI	TX80D12VCOCCAB	BN07-00169A	HIZ		*Development new panel for Hitachi 32" TV (ZPD)
HITACHI	TX54D11VCOCCAB	BN07-00123B	HIZ		Hitachi 21.3"ZPD panel
IBM	ITSX94S	BN07-00017A	IA		-
UNIPAC	UM170E0	BN07-00028A	UA		Loaded by cisdba
HYUNDAI	HT15X13	BN07-00035A	DA		-
HYUNDAI	HT17E11-200	BN07-00049A	DB		TN MODE
HYUNDAI	HT17E11-300	BN07-00093A	DC		HT17E11-300 ZPD panel
HYUNDAI	HT17E11-400	BN07-00094A	DD		HT17E11-400 normal panel
HYUNDAI	HT17E11-400	BN07-00095A	DE		HT17E11-400 ZPD panel code
HYUNDAI	HT17E12	BN07-00096A	DF		HT17E12 (Narrow & slim Design)
HYUNDAI	HT17E12	BN07-00105A	DG		ZPD Panel code
HYUNDAI	HT15X15-D00	BN07-00146A	DH		*Development for Ares 15" Hydis TV"
HYUNDAI	HT15X15-D01	BN07-00146B	DJ		*Derivation panel HPD for Ares 15" Hydis TV "
HYUNDAI	HT17E13-100	BN07-00167A	DTH		*PINEHURST-2(BM) PJT 17" HYDIS PANEL Derivation"
HYUNDAI	HT17E13-100	BN07-00167B	DTZ		*PINEHURST-2(BM) Hydis 17" ZPD code Derivation"
ACER	L170E3	BN07-00044A	AA		TN(ADT)
ACER	M170EN05	BN07-00076A	AB		AU 17" Panel (Narrow & slim design)
ACER	M170EN05	BN07-00102A	AC		ZPD Panel code
ACER	M190EN02	BN07-00170A	AMH		*AU Monitor 19" new panel development (P19-1S)
ACER	M190EN02	BN07-00170B	AMZ		*AU 19" ZPD code derivation (ZPD)"
ACER	M170EN06	BN07-00171A	ATH		*AU Monitor 17" New panel development "
ACER	T260XW01	BN07-00163A	AMZ		*AU 26" new panel development (NF26E0)"
ACER	A201SN01	BN07-00177A	ATZ		*AU TV panel 20.1" TN SVGA new panel development"
ACER	M170EN06	BN07-00171B	ATZ		AU Monitor 17" ZPD code derivation
ACER	T315XW01	BN07-00194A	AMZ		AU 32" new
ACER	M170EG01	BN07-00192A	ATH		AU TN PSWG type new Panel code
ACER	M170EG01	BN07-00192B	ATZ		AU TN PSWG type NEW panel code derivation
ACER	M190EN04	BN07-00203A	ATH		AU Monitor 19" ZPD new Panel code
ACER	T260XW02	BN07-00208A	AMZ		AUO 26" ZPD panel
ACER	M170EG01 V8	BN07-00221A	ATZ		AU TN PSWG type new Panel (8mssec) ZPD code derivation
ACER	T260XW02	BN07-00233A	AMZ		AUO 26" Panel new (Cosmetic spec down grade)
ACER	T315XW01	BN07-00234A	AMZ		AUO 32" Grade new (Cosmetic spec down grade)
ACER	M190EN03	BN07-00224A	AMZ		AU Monitor 19" MVA new code derivation
ACER	T315XW01	BN07-00237A	AMZ		LCD TV VE project new
ACER	T315XW01	BN07-00238A	AMZ		LCD TV VE project new
ACER	M201UN02 V3	BN07-00168A	AMZ		
CHIMEI	M170E3-L01	BN07-00050A	CA		TN PANEL
CHIMEI	M150X3-L01	BN07-00051A	CB		COMPATIBLE
CHIMEI	M170E4-L01	BN07-00052A	CC		MVA PANEL
CHIMEI	M150X2-L01	BN07-00066A	CD		CHIMEI 15" PVA PANEL
CHIMEI	M150X3-L01	BN07-00079A	CE		Chimei ZPD panel
CHIMEI	M170E3-L01	BN07-00103A	CF		ZPD Panel code
CHIMEI	M170E4-L01	BN07-00104A	CG		ZPD Panel code
CHIMEI	V296W1-L01	BN07-00120A	CH		MVA
CHIMEI	M170E6-L02	BN07-00126A	CJ		HIGHLAND 17" LOW PANEL
CHIMEI	M190E2-L01	BN07-00131A	CK		GH19AS,BS CHIMEI PANEL
CHIMEI	M150X4-L06	BN07-00137A	CL		15" Narrow & Slim panel
CHIMEI	M170E6-L01	BN07-00133A	CM		"2003-03-11 vendor change"
CHIMEI	M170E6-L01	BN07-00133B	CN		ZPD derivation panel
CHIMEI	V201V1-T01	BN07-00135A	CP		CHIMEI 20.1" panel development
CHIMEI	M170E6-L02	BN07-00126B	CQ		"HIGHLAND 17" LOW PANEL ZPD derivation panel"
CHIMEI	M170E6-L05	BN07-00152A	CR		"CMO 17" new panel development code"
CHIMEI	M170E6-L05	BN07-00152B	CS		"CMO 17" ZPD panel code derivation"
CHIMEI	M150X4-L06	BN07-00137B	CT		Chimei 15" Narrow & Slim panel ZPD derivation
CHIMEI	M170E5-L05	BN07-00165A	CTH		CMO 17" new panel development code (GOYA2-PJT)
CHIMEI	M170E5-L05	BN07-00165B	CTZ		CMO 17" ZPD panel(GOYA2-PJT)
CHIMEI	V230W1-L02	BN07-00209A	CMZ		CMO 23" development
CHIMEI	V320B1-L01	BN07-00207A	CMZ		CMO 32" development
CHIMEI	V270W1-L01	BN07-00136A	CMZ		CHI MEI 27" panel development
NEC	SVA150XG04TB	BN07-00225A	BTZ		SVA NEC 15" panel ZPD code

Memo

4 Troubleshooting

4-1 No Power

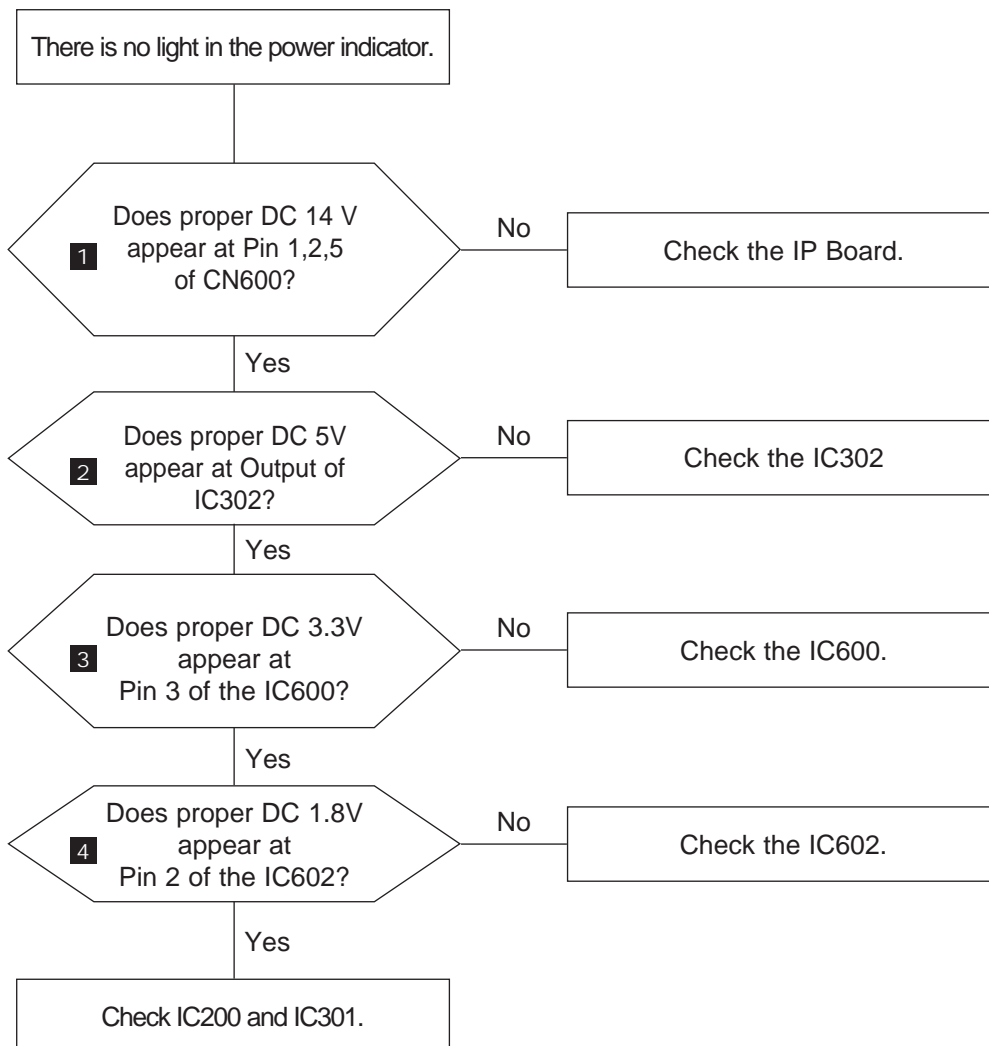

WAVEFORMS

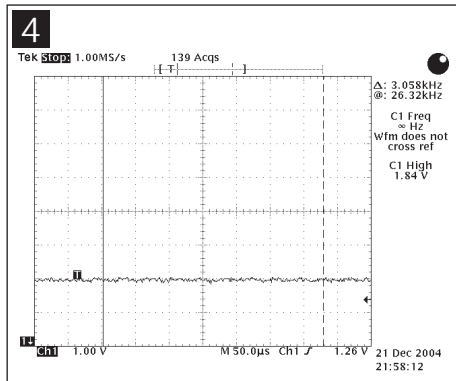
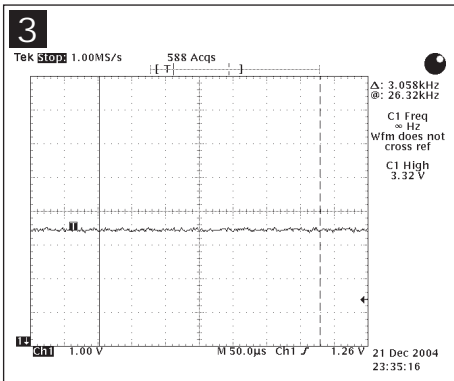
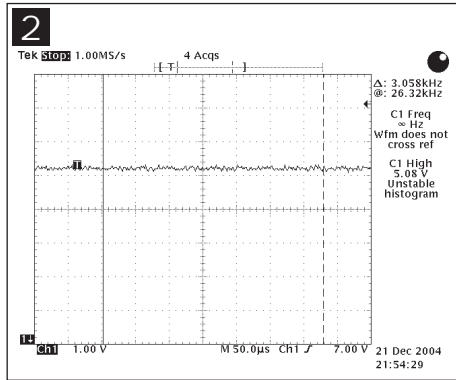
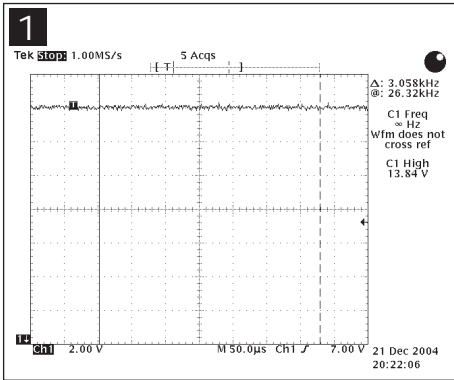

4-2 No Video (PC Analog Signal)

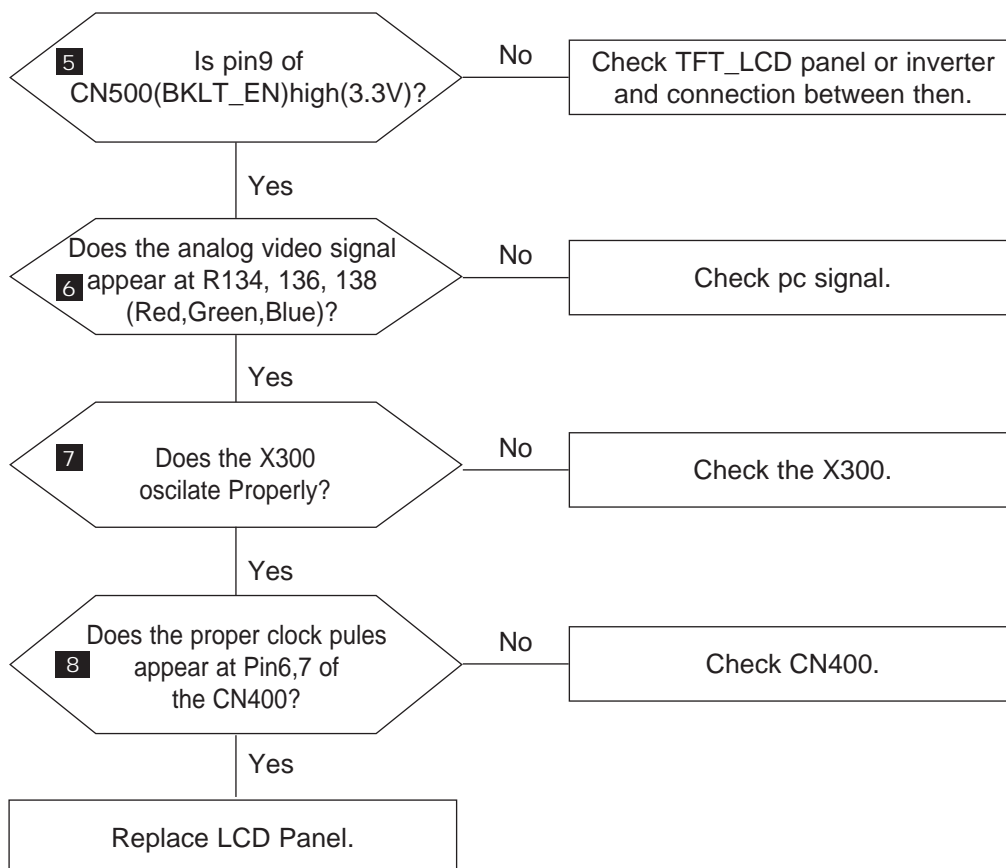

WAVEFORMS

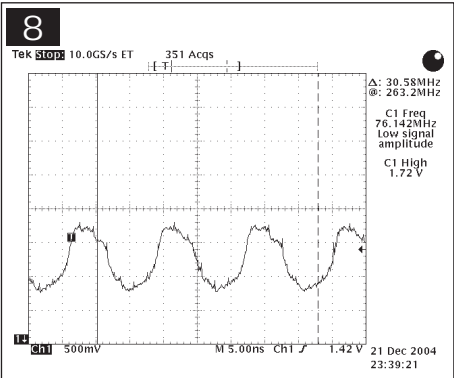
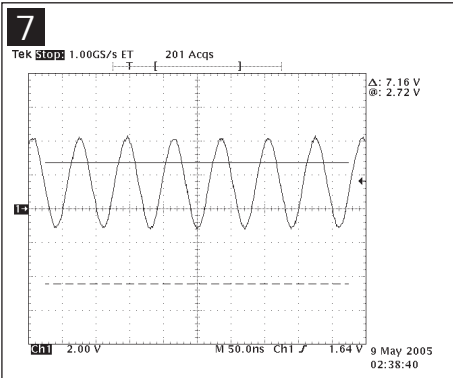
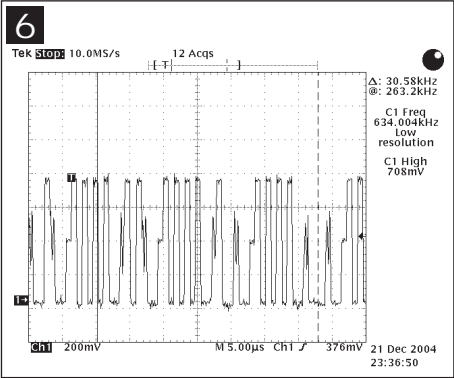
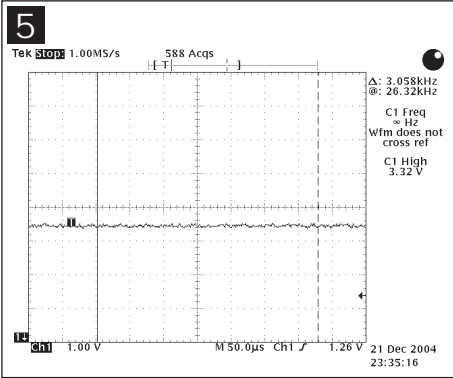

4-3 No Video (PC Digital Signal)

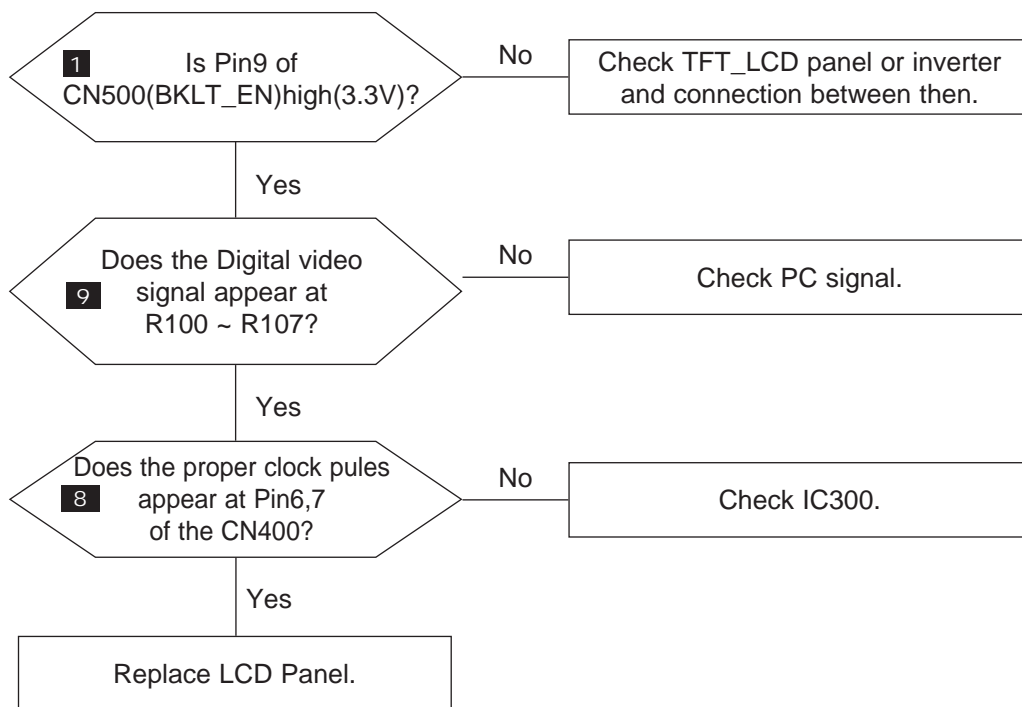

WAVEFORMS

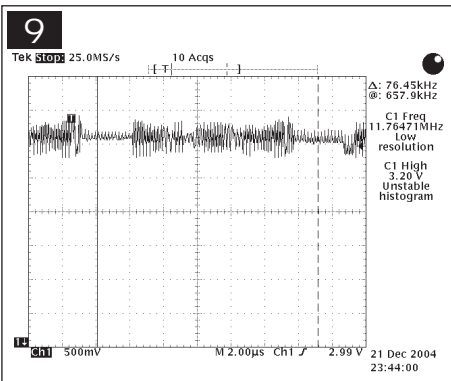
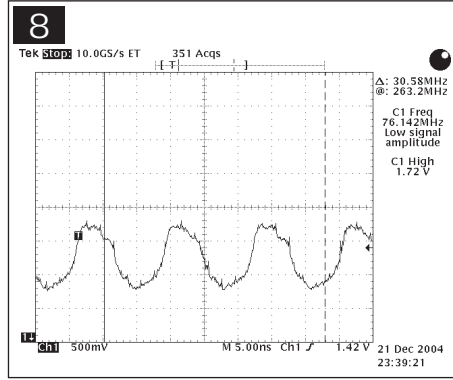
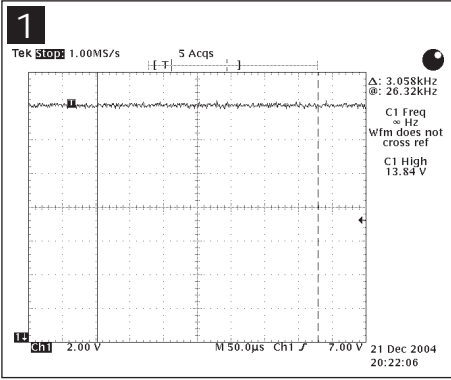

3 Alignments and Adjustments

This section of the service manual explains how to use the RS232 JIG.
This function is needed for AD board change.

3-1 Required Equipment

The following equipment is necessary for adjusting the monitor:

- Computer with Windows 95, Windows 98, Windows NT, Windows 2000, or Windows XP.
- MTI-2031 DDC MANAGER JIG

3-2 Automatic Color Adjustment

To Analog video, In 16gray or any pattern using black and white and any mode.(16gray and XGA mode recommend)

1. Push the OSD Menu button to open the OSD
2. Select language English
3. Push enter button during 5 seconds.
4. See the screen flashing

3-3 DDC EDID Data Input

1. Input DDC EDID data when replacing AD PCB.
2. Receive/Download the proper DDC file for the model from HQ quality control department.
Install the below jig (Figure 1) and enter the data.

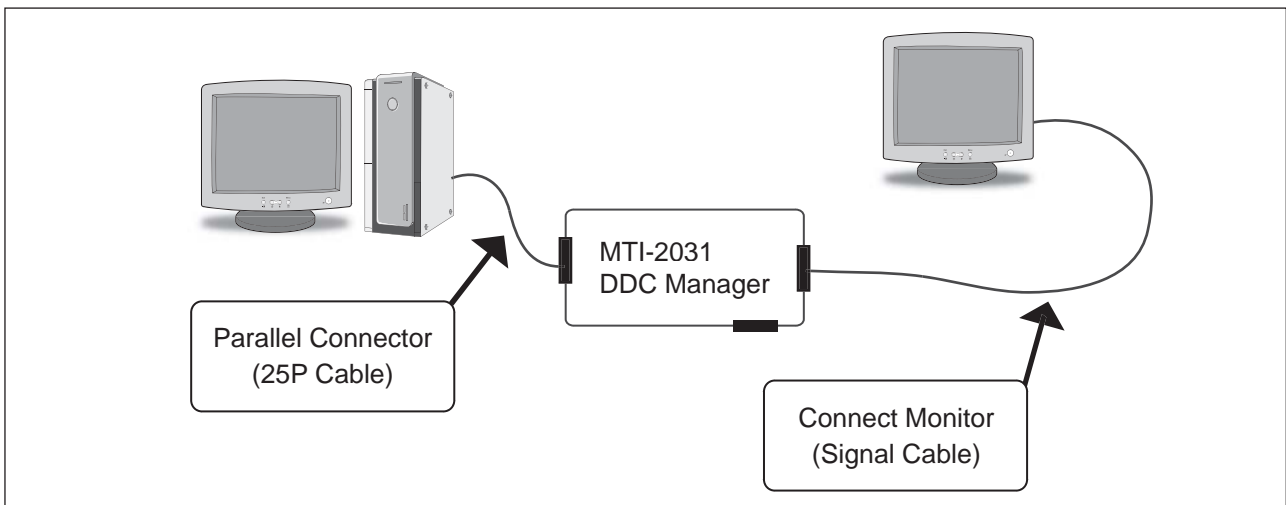

Figure 1.

3-4 Service Function Spec.

3-4-1 How to Display Service Function OSD

1. After setting both brightness and contrast to '0' push the 'enter' button more than 5 seconds.
2. service function appear as below.

Service Function			
Monitor On Time:			42Hr
Panel Cycle	:		13
		Time	Ch. No
Panel:	:	42Hr	165
Lower Lamp:		42Hr	165
Upper Lamp:		42Hr	165
Version : TM-Haydn20WW-0714			
Checksum :			

Figure 2.

3-4-2 How to Control Service Function OSD

1. Monitor On Time : Power on time
2. Panel Cycle : Panel on/off time(Power off, mode change, DPMS on/off..)
3. Panel : Panel on time
(Each time the panel is replaced press the menu key for 5 seconds to add to the Ch. No. indicating the number of time the panel has been changed.)
4. Upper lamp : Upper lamp on time
(When the upper lamp is replaced press menu to add to the Ch. No. which shows the number of times the lamp has been replaced.)
5. Lower lamp : lower lamp on time
(When the upper lamp is replaced press menu to add to the Ch. No. which shows the number of times the lamp has been replaced.)
6. Auto auto : If Auto auto menu set to on, when the mode is changed for the first time, Auto adjust function is performed. Default is on
7. Pixel Shift : Not used
8. Country : OSD language can be changed with this menu to World wide, Korean, China, or Japanese.

You can navigate the menu with "+"key, and adjust with "menu key" pressing 5 seconds(Panel, Upper Lamp, and Lower Lamp memu). You can also control Auto auto, Pixel Shift, and country menu with pressing "-"key.

3-5 Hidden Key list

No	Function	Action method
1.	Hidden Service Function	<ul style="list-style-type: none"> - After setting brightness and contrast '0' push the "Enter" button more than 5 seconds. - Service Function appear.
2.	Factory Reset	<ul style="list-style-type: none"> - While Menu is opened(any menu), press "enter" key over 5 seconds. - Screen is flashing, then all menus return to the factory default.
3.	Auto calibration	<p>To Analog video, In 16gray or any pattern using black and white and any mode.(16gray and XGA mode recommend)</p> <ol style="list-style-type: none"> 1. Push the OSD Menu button to open the OSD. 2. Select language English. 3. Push enter button during 5 seconds. 4. Screen is flashed and auto calibration is completed.
4.	OSD lock	<ul style="list-style-type: none"> - Press the menu key over 5 seconds, then OSD is locked . - To unlocked the OSD, press the memu key over 5 seconds.

3 Alignments and Adjustments

3-6 DDC Input Method(Windows Program)

After change a Main Board ,DDC input shpuld be done via DDC control JIG.
Connecting method is refer to below picture.

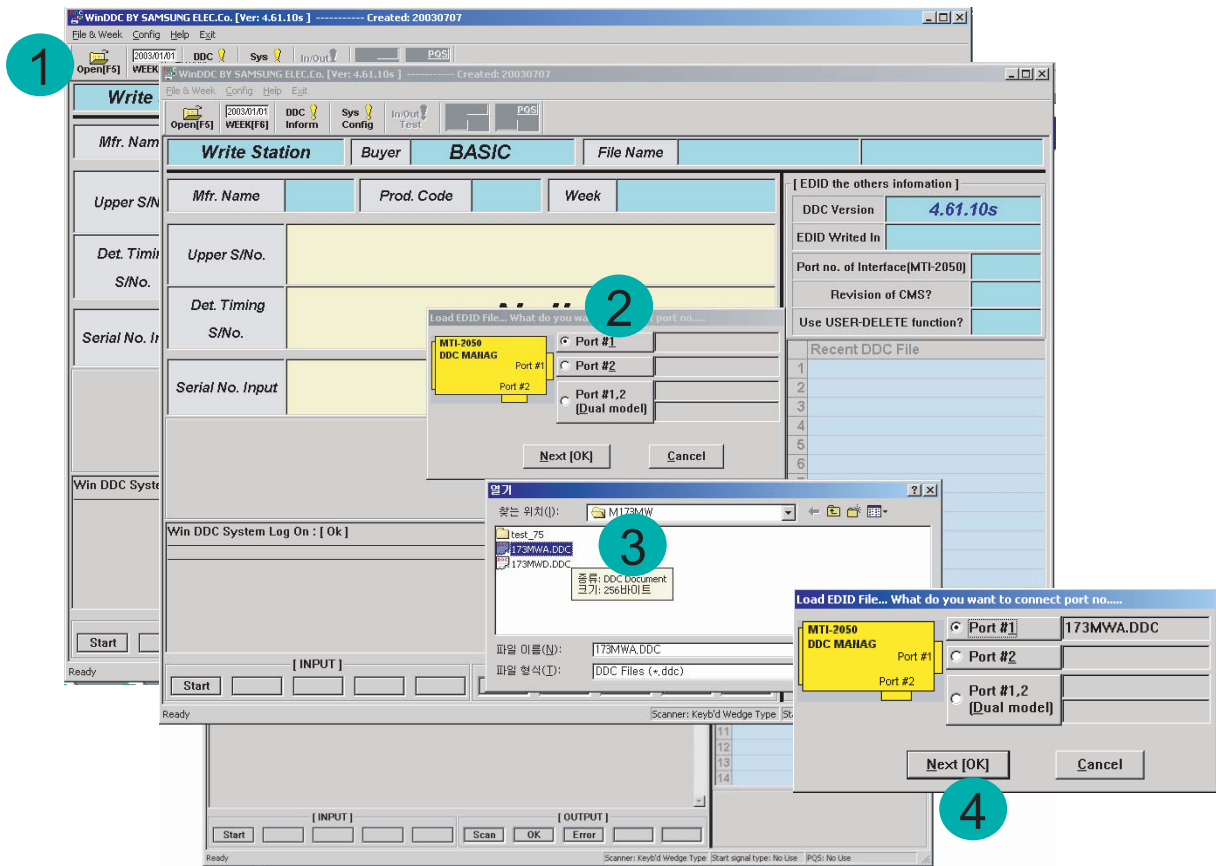
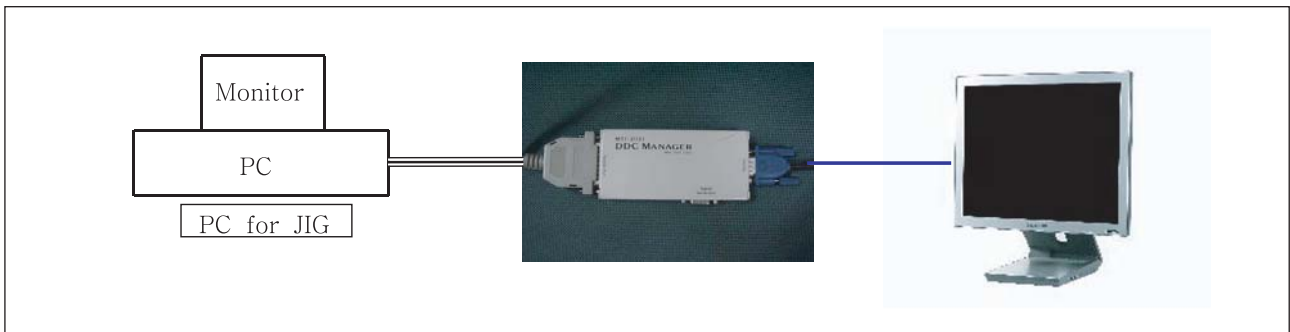

1. Winddc.exe Program install in PC

2. Cilk the Winddc icon.

3. File open.

4. Select Port#1

Load DDC fileFile Name

- "SM205BWA.ddc"

- "SM205BWD.ddc"

Click Next(OK) button.

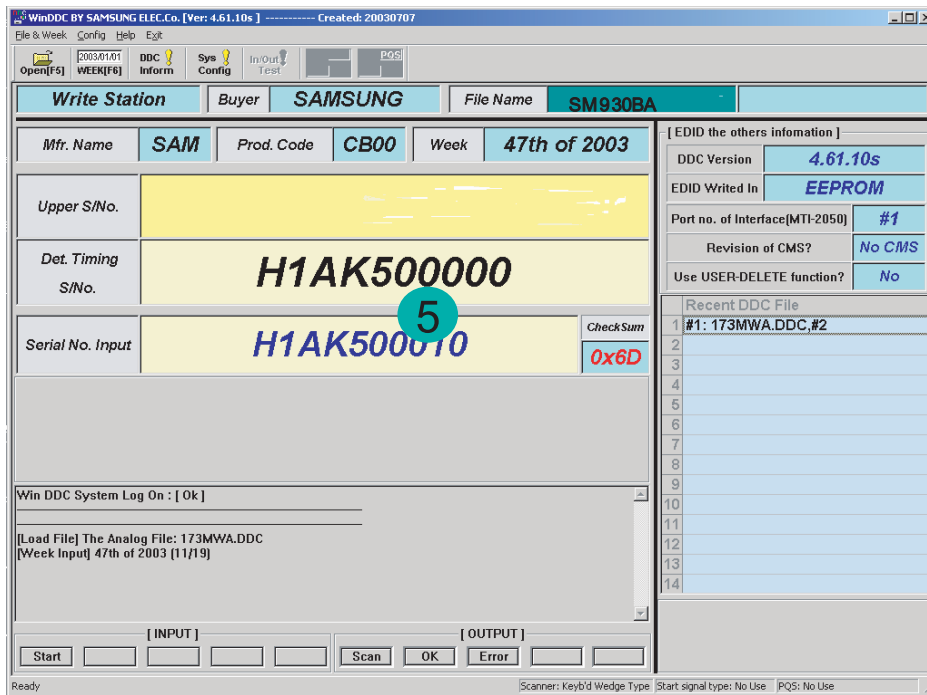

5: Input a monitor serial number and push the enter key.

After Analog input, Please do # 2 ~ 5 when digital input.

3-7 Execution Items after replacing the main board

After Replacing the Maing Board

1. Auto Calibration
2. EDID installation(Analog and Digital)
3. Factory Reset

Memo

6 Electrical Parts List

-You can search for updated part codes through ITSELF web site.

URL : <http://itself.sec.samsung.co.kr/>

6-1 LS20HAWCSZ/EDC Parts List

Level	Loc. No.	Code No.	Description & Specification	Q'ty	SA/SNA
		LS20HAWCSZ/EDC	205BW,WPA1/S20B2-LHA,20,LCD-MO,NETHERLAN		
0.1	M0001	BN90-00900G	ASSY COVER FRONT;ATZ-LS20HAWCSZ/EDC,4Imp	1	S.N.A
..2	T0003	BN96-03328F	ASSY COVER P-FRONT;LS20HAW,ABS HB,GR70,S	1	S.A
...3	M0112	BN63-02513B	COVER-FRONT;LS20HAW(205BW),ABS,HB,GR70,S	1	S.N.A
...3	T0022	BN64-00377B	KNOB CONTROL;HA17TS,PC CLEAR,T2.1.9,112,	1	S.N.A
...3	M0145	BN96-02474C	ASSY BOARD P-FUNCTION;HAYDN,YWP-VD-05-05	1	S.A
....4	M0014	BN94-01300K	ASSY PCB MAIN-SEDA,FUCHION PCB;HAYDN*	1	S.N.A
.....5	CIS	0203-001809	TAPE-DOUBLE FACE;467MP,-,W7.80,L106.67	1	S.N.A
.....5	SW1	BN34-00001A	SWITCH-DOME SHEET;HYADN_FUNCTION F/K,DOM	1	S.A
.....5	SW2	BN34-00001A	SWITCH-DOME SHEET;HYADN_FUNCTION F/K,DOM	1	S.A
.....5	SW3	BN34-00001A	SWITCH-DOME SHEET;HYADN_FUNCTION F/K,DOM	1	S.A
.....5	SW4	BN34-00001A	SWITCH-DOME SHEET;HYADN_FUNCTION F/K,DOM	1	S.A
.....5	SW5	BN34-00001A	SWITCH-DOME SHEET;HYADN_FUNCTION F/K,DOM	1	S.A
.....5	SW6	BN34-00001A	SWITCH-DOME SHEET;HYADN_FUNCTION F/K,DOM	1	S.A
.....5	M2893	BN39-00688A	LEAD CONNECTOR;HAYDN,UL1571#30,4P,450mm,	1	S.A
.....5	CIS	BN61-01846A	GUIDE-CONTROL;HA17T,ABS HB,T1.1.9,112,IV	1	S.N.A
.....5	T0174	BN97-01589K	ASSY SMD;HAYDN*	1	S.N.A
.....6	L0405	0601-001896	LED;SMD,BLUE,1.6x0.8x0.4mm,470,1.6x0.8x0	1	S.A
.....6	R3	2007-000081	R-CHIP;2.7Kohm,5%,1/10W,TP,1608	1	S.A
.....6	R4	2007-000081	R-CHIP;2.7Kohm,5%,1/10W,TP,1608	1	S.A
.....6	R1	2007-000123	R-CHIP;1.5Kohm,5%,1/10W,TP,1608	1	S.A
.....6	R2	2007-000123	R-CHIP;1.5Kohm,5%,1/10W,TP,1608	1	S.A
.....6	CN330	3711-005935	HEADER-BOARD TO CABLE;BOX,4P,1R,1mm,SMD-	1	S.A
.....6	T0077	BN41-00633A	PCB MAIN;HAYDN,FR4,2L,MP1.0,0.6T,105*8,1	1	S.N.A
0.1	M0216	BN90-00907D	ASSY STAND;LS20HAWCSZ/EDC,4LMP	1	S.N.A
..2	M0003	BN96-05837A	ASSY STAND P;LS19HAW (WIDE),HIPS HB,BK24	1	S.A
...3	T0081	6001-001547	SCREW-MACHINE;BH,+,M4,L10(5),ZPC(BLK),SW	2	S.A
...3	M0081	6003-000275	SCREW-TAPTITE;BH,+,-,B,M3,L10,ZPC(BLK),S	5	S.N.A
...3	M0081	6003-000337	SCREW-TAPTITE;BH,+,S,M4,L10,ZPC(BLK),SWR	4	S.A
...3	M0081	6003-001001	SCREW-TAPTITE;FH,+,B,M3,L8,ZPC(BLK),SWRC	7	S.N.A
...3	HC+CW	6009-001370	SCREW-SPECIAL;PWH,+,-,M4,L8,ZPC(WHT),SWR	1	S.N.A
...3		BN61-00875A	GUIDE-WASHER;HS15PO,SK-5,T0.5,NTR	4	S.N.A
...3		BN61-01396A	HOLDER-SWIVEL RING;MJ17MS,ACETAL,NTR	1	S.N.A
...3	M0114	BN61-01397A	HOLDER-WIRE;MJ17MS,ABS HB,BK07	1	S.N.A
...3		BN61-01404A	BRACKET-STAND BOTTOM;MJ17MS,SECC,T2.0	1	S.N.A
...3	CIS4	BN61-01438A	HOLDER-STAND;MATISSE HAS-STAND,SWRCH18A	1	S.N.A
...3		BN61-02073A	BRACKET-STAND LIFT;HA17TS,SECC,T2.0,52.5	1	S.N.A
...3		BN61-02074A	GUIDE-STAND BODY;HA17TS,ACETAL,T1.5,19.8	2	S.N.A
...3		BN61-02075A	GUIDE-STAND LIFT;HA17TS,ACETAL,T2.0,57.6	1	S.N.A
...3		BN61-02433A	BRACKET-STAND BODY;S/M 205BW,SECC,T2.0	1	S.N.A
...3	M0412	BN63-01515D	COVER-SWIVEL BASE;MATISSE,HIPS,T2.5,200,	1	S.N.A
...3	M0174	BN63-01983B	COVER-STAND TOP;HA17,HIPS,T2.5,200,200,H	1	S.N.A
...3	T0003	BN63-01984A	COVER-STAND BOTTOM;HA17TS,HIPS,T2.5,200,	1	S.N.A
...3		BN63-02206A	COVER-STAND SUB;HA17TS,HIPS,T2.0,80,100,	1	S.N.A
...3		BN63-02524B	COVER-STAND REAR;LS20HAW(205BW),HIPS,HB,	1	S.N.A
...3		BN63-02525A	COVER-STAND TILT;S/M 205BW,HIPS,HB,BK24	1	S.N.A
...3		BN63-02526A	COVER-STAND FRONT;S/M 205BW,HIPS,HB,BK24	1	S.N.A

6 Electrical Parts List

Level	Loc. No.	Code No.	Description & Specification	Q'ty	SA/SNA
...3	T0132	BN73-00077A	RUBBER FOOT;MATISSE,BUMPON, ³13.5,T2.0,6	4	S.NA
...3	T0081	BN73-00085A	RUBBER CUSHION;MATISSE, ³4.5(IN SIDE),CL	1	S.NA
...3	M0007	BN96-01524A	ASSY STAND P-STOPPER;MJ17BS,SUS T1.0,L26	1	S.NA
...3	M0126	BN96-02310A	ASSY STAND P-SPRING;HA19TS,SUS301	2	S.NA
...3	T0054	BN96-05355A	ASSY HINGE P;940B,HGI,SGCC,T2.0	1	S.A
...4		BN60-00040A	SPACER-WASHER;940B,SK-5,8.0,14.0,0.4	4	S.NA
...4		BN61-03141A	BRACKET-HINGE TILT;940B,HGI, SGCC,T2.0	1	S.NA
...4	T0530	BN61-03184A	SPRING ETC-COIL;940B,SWPB,3.0,15.0,19.0,	1	S.NA
...4	T0530	BN61-03185A	SPRING ETC-COIL;940B,SWPB,3.0,15.0,19.0,	1	S.NA
...4		BN61-03208A	SPRING ETC-DISK;940B,SK-5,8.0,14.5,0.85	4	S.NA
...4		BN61-03263A	BRACKET-STAND VESA;940B,HGI, SGCC,T2.0	1	S.NA
...4		BN66-00009A	SHAFT-HINGE;940B,SUM24L,16.5,14	2	S.NA
0.1	M0002	BN90-01220A	ASSY COVER REAR;ATZ-LS20HAWCSZ/EDC,205BW	1	S.NA
..2	M0013	BN96-04799A	ASSY COVER P-REAR;LS20HAW,HIPS HB,BK24,4	1	S.A
...3	M0006	BN63-03158A	COVER-REAR;LS20HAW,HIPS HB,BK24,4LAMP	1	S.NA
...3	M0126	BN73-00049E	RUBBER-FOOT;LS20MEW,RUBBER,CR,LIGHT GRAY	4	S.NA
0.1	M0112	BN91-01028B	ASSY SHIELD;ATZ-LS20HAWCSZ/EDC,205BW,4LM	1	S.NA
..2		BN63-03157A	SHIELD-LAMP;LS20HAW,SPTe,T0.3,4LAMP	1	S.NA
0.1	M0017	BN91-01408F	ASSY CHASSIS-ATZ;WW;LS20HAW*,4LAMP	1	S.A
..2	M0081	6003-000115	SCREW-TAPTITE;BH,+,B,M3,L6,ZPC(BLK),SWRC	4	S.A
..2	M0081	6003-001439	SCREW-TAPTITE;BH,+,-,S,M4,L8,ZPC(WHT),SW	1	S.NA
..2	T0562	6046-001013	STAND OFF;M3,L5,Ni PLT,SUM24L,#4-40	4	S.NA
..2	M2893	BN39-00664F	LEAD CONNECTOR-LVDS;HAYDN,UL1571#30,UL/C	1	S.A
..2	M0174	BN44-00127N	IP BOARD;IP-43130A(BW),205BW,3.0 -5.0mA,	1	S.A
..2		BN61-02426A	BRACKET-SHIELD;S/M 203B,SPTe,T0.3	1	S.NA
..2	M0014	BN94-01204H	ASSY PCB MAIN-ATZ,WW;LS20HAW*,4LAMP	1	S.NA
...3	T0245	0202-001492	SOLDER-WIRE FLUX;HSE-02 LFM48 SR-34 S,-,	0.003	S.NA
...3	CN102	3701-001173	CONNECTOR-DVI;24P,3R,FEMALE,ANGLE,AUF	1	S.A
...3	CN101	3701-001219	CONNECTOR-DSUB;15P,3R,FEMALE,ANGLE,AUF	1	S.A
...3	CN400	3711-005884	HEADER-BOARD TO BOARD;BOX,30P,2R,2mm,ANG	1	S.A
...3	HDCP	BN97-00688A	ASSY HDCP;BN46-00018A,PS-42V6S,D73A,GENE	1	S.NA
...4		BN46-00018A	KEY CODE-CERTIFICATE;(HDCP KEY)PPM42M5S,	1	S.NA
...3	T0174	BN97-01414J	ASSY SMD;LS20HAW*	1	S.NA
...4	D100	0401-001056	DIODE-SWITCHING;MMBD4148SE,100V,200mA,SO	1	S.A
...4	D101	0401-001056	DIODE-SWITCHING;MMBD4148SE,100V,200mA,SO	1	S.A
...4	D102	0401-001056	DIODE-SWITCHING;MMBD4148SE,100V,200mA,SO	1	S.A
...4	D103	0401-001056	DIODE-SWITCHING;MMBD4148SE,100V,200mA,SO	1	S.A
...4	D104	0401-001056	DIODE-SWITCHING;MMBD4148SE,100V,200mA,SO	1	S.A
...4	D105	0401-001056	DIODE-SWITCHING;MMBD4148SE,100V,200mA,SO	1	S.A
...4	D106	0401-001056	DIODE-SWITCHING;MMBD4148SE,100V,200mA,SO	1	S.A
...4	D107	0401-001056	DIODE-SWITCHING;MMBD4148SE,100V,200mA,SO	1	S.A
...4	D108	0401-001056	DIODE-SWITCHING;MMBD4148SE,100V,200mA,SO	1	S.A
...4	D110	0401-001056	DIODE-SWITCHING;MMBD4148SE,100V,200mA,SO	1	S.A
...4	D125	0401-001056	DIODE-SWITCHING;MMBD4148SE,100V,200mA,SO	1	S.A
...4	D126	0401-001056	DIODE-SWITCHING;MMBD4148SE,100V,200mA,SO	1	S.A
...4	D127	0401-001056	DIODE-SWITCHING;MMBD4148SE,100V,200mA,SO	1	S.A
...4	D301	0402-001098	DIODE-RECTIFIER;SK34,40V,3A,SMC,TP	1	S.A
...4	D109	0403-001411	DIODE-ZENER;- ,5.49-5.73V,200mW,SOD-323,T	1	S.A
...4	D123	0403-001411	DIODE-ZENER;- ,5.49-5.73V,200mW,SOD-323,T	1	S.A
...4	D124	0403-001411	DIODE-ZENER;- ,5.49-5.73V,200mW,SOD-323,T	1	S.A
...4	D220	0403-001411	DIODE-ZENER;- ,5.49-5.73V,200mW,SOD-323,T	1	S.A
...4	D230	0403-001411	DIODE-ZENER;- ,5.49-5.73V,200mW,SOD-323,T	1	S.A

Level	Loc. No.	Code No.	Description & Specification	Q'ty	SA/SNA
....4	D231	0403-001411	DIODE-ZENER;-5.49-5.73V,200mW,SOD-323,T	1	SA
....4	D221	0406-001061	DIODE-TVS;MMQA5V6T3,5.32/5.6/5.88V,24W,S	1	SA
....4	D232	0406-001061	DIODE-TVS;MMQA5V6T3,5.32/5.6/5.88V,24W,S	1	SA
....4	ZD200	0406-001061	DIODE-TVS;MMQA5V6T3,5.32/5.6/5.88V,24W,S	1	SA
....4	Q201	0501-000342	TR-SMALL SIGNAL;KSC1623-Y,NPN,200mW,SOT-	1	SA
....4	Q302	0501-002080	TR-SMALL SIGNAL;2SC2412K,NPN,200mW,SC-59	1	SA
....4	Q409	0505-001957	FET-SILICON;NTR2101P,P,-8V,-3.7A,0.052oh	1	SA
....4	IC112	1103-000129	IC-EEPROM;24C02,2Kbit,256x8Bit,SOP,8P,5x	1	SA
....4	IC112	1103-000129	IC-EEPROM;24C02,2Kbit,256x8Bit,SOP,8P,5x	1	SA
....4	IC112	1103-001023	IC-EEPROM;24C08,8Kbit,1Kx8Bit,SOP,8P,5x4	1	SA
....4	IC303	1203-001212	IC-VOL. DETECTOR;7029,SOT-89,3P,-,PLASTI	1	SA
....4	T0170	1203-003059	IC-SWITCH VOL. REG.;MP1583,SOIC,8P,4.9x3	1	SA
....4	T0087	1203-003060	IC-POSI.FIXED REG.;AP1084,TO-263,3P,9.97	1	SA
....4	T0087	1203-003696	IC-POSI.FIXED REG.;NCP1117DT18T5G,DPAK,3	1	SA
....4	IC109	1205-003036	IC-LCD CONTROLLER;GM5766H-LF-AB,PQFP,128	1	SA
....4	R316	2007-000070	R-CHIP;0ohm,5%,1/10W,TP,1608	1	SA
....4	R333	2007-000070	R-CHIP;0ohm,5%,1/10W,TP,1608	1	SA
....4	R100	2007-000071	R-CHIP;22ohm,5%,1/10W,TP,1608	1	SA
....4	R101	2007-000071	R-CHIP;22ohm,5%,1/10W,TP,1608	1	SA
....4	R102	2007-000071	R-CHIP;22ohm,5%,1/10W,TP,1608	1	SA
....4	R103	2007-000071	R-CHIP;22ohm,5%,1/10W,TP,1608	1	SA
....4	R104	2007-000071	R-CHIP;22ohm,5%,1/10W,TP,1608	1	SA
....4	R105	2007-000071	R-CHIP;22ohm,5%,1/10W,TP,1608	1	SA
....4	R106	2007-000071	R-CHIP;22ohm,5%,1/10W,TP,1608	1	SA
....4	R107	2007-000071	R-CHIP;22ohm,5%,1/10W,TP,1608	1	SA
....4	R129	2007-000071	R-CHIP;22ohm,5%,1/10W,TP,1608	1	SA
....4	R130	2007-000071	R-CHIP;22ohm,5%,1/10W,TP,1608	1	SA
....4	R224	2007-000071	R-CHIP;22ohm,5%,1/10W,TP,1608	1	SA
....4	R225	2007-000071	R-CHIP;22ohm,5%,1/10W,TP,1608	1	SA
....4	R125	2007-000074	R-CHIP;100ohm,5%,1/10W,TP,1608	1	SA
....4	R126	2007-000074	R-CHIP;100ohm,5%,1/10W,TP,1608	1	SA
....4	R134	2007-000074	R-CHIP;100ohm,5%,1/10W,TP,1608	1	SA
....4	R136	2007-000074	R-CHIP;100ohm,5%,1/10W,TP,1608	1	SA
....4	R138	2007-000074	R-CHIP;100ohm,5%,1/10W,TP,1608	1	SA
....4	R142	2007-000074	R-CHIP;100ohm,5%,1/10W,TP,1608	1	SA
....4	R143	2007-000074	R-CHIP;100ohm,5%,1/10W,TP,1608	1	SA
....4	R144	2007-000074	R-CHIP;100ohm,5%,1/10W,TP,1608	1	SA
....4	R212	2007-000074	R-CHIP;100ohm,5%,1/10W,TP,1608	1	SA
....4	R213	2007-000074	R-CHIP;100ohm,5%,1/10W,TP,1608	1	SA
....4	R222	2007-000074	R-CHIP;100ohm,5%,1/10W,TP,1608	1	SA
....4	R223	2007-000074	R-CHIP;100ohm,5%,1/10W,TP,1608	1	SA
....4	R233	2007-000074	R-CHIP;100ohm,5%,1/10W,TP,1608	1	SA
....4	R234	2007-000074	R-CHIP;100ohm,5%,1/10W,TP,1608	1	SA
....4	R309	2007-000074	R-CHIP;100ohm,5%,1/10W,TP,1608	1	SA
....4	R313	2007-000074	R-CHIP;100ohm,5%,1/10W,TP,1608	1	SA
....4	R328	2007-000074	R-CHIP;100ohm,5%,1/10W,TP,1608	1	SA
....4	R329	2007-000074	R-CHIP;100ohm,5%,1/10W,TP,1608	1	SA
....4	R332	2007-000074	R-CHIP;100ohm,5%,1/10W,TP,1608	1	SA
....4	R604	2007-000074	R-CHIP;100ohm,5%,1/10W,TP,1608	1	SA
....4	R306	2007-000078	R-CHIP;1Kohm,5%,1/10W,TP,1608	1	SA
....4	R610	2007-000078	R-CHIP;1Kohm,5%,1/10W,TP,1608	1	SA
....4	R109	2007-000080	R-CHIP;2Kohm,5%,1/10W,TP,1608	1	SA
....4	R128	2007-000080	R-CHIP;2Kohm,5%,1/10W,TP,1608	1	SA
....4	R201	2007-000082	R-CHIP;3.3Kohm,5%,1/10W,TP,1608	1	SA
....4	R202	2007-000082	R-CHIP;3.3Kohm,5%,1/10W,TP,1608	1	SA

6 Electrical Parts List

Level	Loc. No.	Code No.	Description & Specification	Q'ty	SA/SNA
...4	R311	2007-000083	R-CHIP;3Kohm,5%,1/10W,TP,1608	1	S.A
...4	R330	2007-000083	R-CHIP;3Kohm,5%,1/10W,TP,1608	1	S.A
...4	R331	2007-000083	R-CHIP;3Kohm,5%,1/10W,TP,1608	1	S.A
...4	R300	2007-000084	R-CHIP;4.7Kohm,5%,1/10W,TP,1608	1	S.A
...4	R307	2007-000084	R-CHIP;4.7Kohm,5%,1/10W,TP,1608	1	S.A
...4	R310	2007-000084	R-CHIP;4.7Kohm,5%,1/10W,TP,1608	1	S.A
...4	R318	2007-000084	R-CHIP;4.7Kohm,5%,1/10W,TP,1608	1	S.A
...4	R319	2007-000084	R-CHIP;4.7Kohm,5%,1/10W,TP,1608	1	S.A
...4	R320	2007-000084	R-CHIP;4.7Kohm,5%,1/10W,TP,1608	1	S.A
...4	R321	2007-000084	R-CHIP;4.7Kohm,5%,1/10W,TP,1608	1	S.A
...4	R322	2007-000084	R-CHIP;4.7Kohm,5%,1/10W,TP,1608	1	S.A
...4	R325	2007-000084	R-CHIP;4.7Kohm,5%,1/10W,TP,1608	1	S.A
...4	R326	2007-000084	R-CHIP;4.7Kohm,5%,1/10W,TP,1608	1	S.A
...4	R327	2007-000084	R-CHIP;4.7Kohm,5%,1/10W,TP,1608	1	S.A
...4	R108	2007-000090	R-CHIP;10Kohm,5%,1/10W,TP,1608	1	S.A
...4	R127	2007-000090	R-CHIP;10Kohm,5%,1/10W,TP,1608	1	S.A
...4	R220	2007-000090	R-CHIP;10Kohm,5%,1/10W,TP,1608	1	S.A
...4	R221	2007-000090	R-CHIP;10Kohm,5%,1/10W,TP,1608	1	S.A
...4	R230	2007-000090	R-CHIP;10Kohm,5%,1/10W,TP,1608	1	S.A
...4	R231	2007-000090	R-CHIP;10Kohm,5%,1/10W,TP,1608	1	S.A
...4	R232	2007-000090	R-CHIP;10Kohm,5%,1/10W,TP,1608	1	S.A
...4	R301	2007-000090	R-CHIP;10Kohm,5%,1/10W,TP,1608	1	S.A
...4	R304	2007-000090	R-CHIP;10Kohm,5%,1/10W,TP,1608	1	S.A
...4	R305	2007-000090	R-CHIP;10Kohm,5%,1/10W,TP,1608	1	S.A
...4	R308	2007-000090	R-CHIP;10Kohm,5%,1/10W,TP,1608	1	S.A
...4	R315	2007-000090	R-CHIP;10Kohm,5%,1/10W,TP,1608	1	S.A
...4	R323	2007-000090	R-CHIP;10Kohm,5%,1/10W,TP,1608	1	S.A
...4	R324	2007-000090	R-CHIP;10Kohm,5%,1/10W,TP,1608	1	S.A
...4	R210	2007-000092	R-CHIP;15Kohm,5%,1/10W,TP,1608	1	S.A
...4	R211	2007-000092	R-CHIP;15Kohm,5%,1/10W,TP,1608	1	S.A
...4	R214	2007-000092	R-CHIP;15Kohm,5%,1/10W,TP,1608	1	S.A
...4	R302	2007-000102	R-CHIP;100Kohm,5%,1/10W,TP,1608	1	S.A
...4	R303	2007-000124	R-CHIP;2.2Kohm,5%,1/10W,TP,1608	1	S.A
...4	R131	2007-000491	R-CHIP;2.2Kohm,1%,1/10W,TP,1608	1	S.A
...4	R132	2007-000491	R-CHIP;2.2Kohm,1%,1/10W,TP,1608	1	S.A
...4	R314	2007-000608	R-CHIP;240ohm,5%,1/10W,TP,1608	1	S.A
...4	R336	2007-000708	R-CHIP;3.9Kohm,1%,1/10W,TP,1608	1	S.A
...4	R337	2007-000965	R-CHIP;5.1Kohm,5%,1/10W,TP,1608	1	S.A
...4	R110	2007-001002	R-CHIP;510ohm,5%,1/10W,TP,1608	1	S.A
...4	R145	2007-001164	R-CHIP;75ohm,1%,1/10W,TP,1608	1	S.A
...4	R146	2007-001164	R-CHIP;75ohm,1%,1/10W,TP,1608	1	S.A
...4	R147	2007-001164	R-CHIP;75ohm,1%,1/10W,TP,1608	1	S.A
...4	R335	2007-007004	R-CHIP;12Kohm,1%,1/10W,TP,1608	1	S.A
...4	C302	2203-000041	C-CER,CHIP;0.01nF,0.25pF,50V,COG,1608	1	S.A
...4	C303	2203-000041	C-CER,CHIP;0.01nF,0.25pF,50V,COG,1608	1	S.A
...4	C203	2203-000189	C-CER,CHIP;100nF,+80-20%,25V,Y5V,1608	1	S.A
...4	C315	2203-000189	C-CER,CHIP;100nF,+80-20%,25V,Y5V,1608	1	S.A
...4	C321	2203-000189	C-CER,CHIP;100nF,+80-20%,25V,Y5V,1608	1	S.A
...4	C318	2203-000236	C-CER,CHIP;0.1nF,5%,50V,COG,1608	1	S.A
...4	C126	2203-000257	C-CER,CHIP;10nF,10%,50V,X7R,1608	1	S.A
...4	C127	2203-000257	C-CER,CHIP;10nF,10%,50V,X7R,1608	1	S.A
...4	C128	2203-000257	C-CER,CHIP;10nF,10%,50V,X7R,1608	1	S.A
...4	C129	2203-000257	C-CER,CHIP;10nF,10%,50V,X7R,1608	1	S.A
...4	C130	2203-000257	C-CER,CHIP;10nF,10%,50V,X7R,1608	1	S.A
...4	C131	2203-000257	C-CER,CHIP;10nF,10%,50V,X7R,1608	1	S.A

Level	Loc. No.	Code No.	Description & Specification	Q'ty	SA/SNA
....4	C201	2203-000257	C-CER,CHIP;10nF,10%,50V,X7R,1608	1	SA
....4	C202	2203-000257	C-CER,CHIP;10nF,10%,50V,X7R,1608	1	SA
....4	C300	2203-000257	C-CER,CHIP;10nF,10%,50V,X7R,1608	1	SA
....4	C313	2203-000257	C-CER,CHIP;10nF,10%,50V,X7R,1608	1	SA
....4	C316	2203-000257	C-CER,CHIP;10nF,10%,50V,X7R,1608	1	SA
....4	C319	2203-000257	C-CER,CHIP;10nF,10%,50V,X7R,1608	1	SA
....4	C121	2203-000384	C-CER,CHIP;0.015nF,5%,50V,C0G,1608	1	SA
....4	C103	2203-000440	C-CER,CHIP;1nF,10%,50V,X7R,1608	1	SA
....4	C122	2203-000626	C-CER,CHIP;0.022nF,5%,50V,C0G,1608	1	SA
....4	C317	2203-000975	C-CER,CHIP;47nF,10%,25V,X7R,TP,1608,-	1	SA
....4	C607	2203-001652	C-CER,CHIP;470nF,+80-20%,16V,Y5V,1608	1	SA
....4	C105	2203-005005	C-CER,CHIP;100nF,10%,16V,X7R,1608	1	SA
....4	C106	2203-005005	C-CER,CHIP;100nF,10%,16V,X7R,1608	1	SA
....4	C110	2203-005005	C-CER,CHIP;100nF,10%,16V,X7R,1608	1	SA
....4	C111	2203-005005	C-CER,CHIP;100nF,10%,16V,X7R,1608	1	SA
....4	C112	2203-005005	C-CER,CHIP;100nF,10%,16V,X7R,1608	1	SA
....4	C113	2203-005005	C-CER,CHIP;100nF,10%,16V,X7R,1608	1	SA
....4	C114	2203-005005	C-CER,CHIP;100nF,10%,16V,X7R,1608	1	SA
....4	C115	2203-005005	C-CER,CHIP;100nF,10%,16V,X7R,1608	1	SA
....4	C116	2203-005005	C-CER,CHIP;100nF,10%,16V,X7R,1608	1	SA
....4	C117	2203-005005	C-CER,CHIP;100nF,10%,16V,X7R,1608	1	SA
....4	C118	2203-005005	C-CER,CHIP;100nF,10%,16V,X7R,1608	1	SA
....4	C119	2203-005005	C-CER,CHIP;100nF,10%,16V,X7R,1608	1	SA
....4	C123	2203-005005	C-CER,CHIP;100nF,10%,16V,X7R,1608	1	SA
....4	C210	2203-005005	C-CER,CHIP;100nF,10%,16V,X7R,1608	1	SA
....4	C220	2203-005005	C-CER,CHIP;100nF,10%,16V,X7R,1608	1	SA
....4	C230	2203-005005	C-CER,CHIP;100nF,10%,16V,X7R,1608	1	SA
....4	C307	2203-005005	C-CER,CHIP;100nF,10%,16V,X7R,1608	1	SA
....4	C308	2203-005005	C-CER,CHIP;100nF,10%,16V,X7R,1608	1	SA
....4	C310	2203-005005	C-CER,CHIP;100nF,10%,16V,X7R,1608	1	SA
....4	C322	2203-005005	C-CER,CHIP;100nF,10%,16V,X7R,1608	1	SA
....4	C610	2203-005005	C-CER,CHIP;100nF,10%,16V,X7R,1608	1	SA
....4	C611	2203-005005	C-CER,CHIP;100nF,10%,16V,X7R,1608	1	SA
....4	C615	2203-005005	C-CER,CHIP;100nF,10%,16V,X7R,1608	1	SA
....4	C616	2203-005005	C-CER,CHIP;100nF,10%,16V,X7R,1608	1	SA
....4	C617	2203-005005	C-CER,CHIP;100nF,10%,16V,X7R,1608	1	SA
....4	C618	2203-005005	C-CER,CHIP;100nF,10%,16V,X7R,1608	1	SA
....4	C619	2203-005005	C-CER,CHIP;100nF,10%,16V,X7R,1608	1	SA
....4	C620	2203-005005	C-CER,CHIP;100nF,10%,16V,X7R,1608	1	SA
....4	C622	2203-005005	C-CER,CHIP;100nF,10%,16V,X7R,1608	1	SA
....4	C623	2203-005005	C-CER,CHIP;100nF,10%,16V,X7R,1608	1	SA
....4	C624	2203-005005	C-CER,CHIP;100nF,10%,16V,X7R,1608	1	SA
....4	C625	2203-005005	C-CER,CHIP;100nF,10%,16V,X7R,1608	1	SA
....4	C635	2203-005005	C-CER,CHIP;100nF,10%,16V,X7R,1608	1	SA
....4	C636	2203-005005	C-CER,CHIP;100nF,10%,16V,X7R,1608	1	SA
....4	C638	2203-005005	C-CER,CHIP;100nF,10%,16V,X7R,1608	1	SA
....4	C639	2203-005005	C-CER,CHIP;100nF,10%,16V,X7R,1608	1	SA
....4	C641	2203-005005	C-CER,CHIP;100nF,10%,16V,X7R,1608	1	SA
....4	C642	2203-005005	C-CER,CHIP;100nF,10%,16V,X7R,1608	1	SA
....4	C643	2203-005005	C-CER,CHIP;100nF,10%,16V,X7R,1608	1	SA
....4	C648	2203-005005	C-CER,CHIP;100nF,10%,16V,X7R,1608	1	SA
....4	C649	2203-005005	C-CER,CHIP;100nF,10%,16V,X7R,1608	1	SA
....4	C650	2203-005005	C-CER,CHIP;100nF,10%,16V,X7R,1608	1	SA
....4	C651	2203-005005	C-CER,CHIP;100nF,10%,16V,X7R,1608	1	SA
....4	C652	2203-005005	C-CER,CHIP;100nF,10%,16V,X7R,1608	1	SA

6 Electrical Parts List

Level	Loc. No.	Code No.	Description & Specification	Q'ty	SA/SNA
....4	C653	2203-005005	C-CER,CHIP;100nF,10%,16V,X7R,1608	1	S.A
....4	C304	2203-005065	C-CER,CHIP;1000nF,+80-20%,10V,Y5V,1608	1	S.A
....4	C305	2203-005065	C-CER,CHIP;1000nF,+80-20%,10V,Y5V,1608	1	S.A
....4	C309	2203-005065	C-CER,CHIP;1000nF,+80-20%,10V,Y5V,1608	1	S.A
....4	C311	2203-005065	C-CER,CHIP;1000nF,+80-20%,10V,Y5V,1608	1	S.A
....4	C312	2203-005065	C-CER,CHIP;1000nF,+80-20%,10V,Y5V,1608	1	S.A
....4	C614	2203-005437	C-CER,CHIP;10000nF,+80-20%,10V,Y5V,3216	1	S.A
....4	C621	2203-005437	C-CER,CHIP;10000nF,+80-20%,10V,Y5V,3216	1	S.A
....4	C634	2203-005437	C-CER,CHIP;10000nF,+80-20%,10V,Y5V,3216	1	S.A
....4	C637	2203-005437	C-CER,CHIP;10000nF,+80-20%,10V,Y5V,3216	1	S.A
....4	C306	2402-001128	C-AL,SMD;100nF,20%,16V,-,TP,6.3X5.7mm	1	S.A
....4	C320	2402-001128	C-AL,SMD;100nF,20%,16V,-,TP,6.3X5.7mm	1	S.A
....4	C608	2402-001128	C-AL,SMD;100nF,20%,16V,-,TP,6.3X5.7mm	1	S.A
....4	C609	2402-001128	C-AL,SMD;100nF,20%,16V,-,TP,6.3X5.7mm	1	S.A
....4	C644	2402-001128	C-AL,SMD;100nF,20%,16V,-,TP,6.3X5.7mm	1	S.A
....4	X300	2801-003667	CRYSTAL-SMD;14.31818MHz,30ppm,28-AAN,16p	1	S.A
....4	T0568	3301-001145	BEAD-SMD;60ohm,4516,TP,70ohm/45MHz,82ohm	1	S.N.A
....4	T0568	3301-001145	BEAD-SMD;60ohm,4516,TP,70ohm/45MHz,82ohm	1	S.N.A
....4	T0568	3301-001145	BEAD-SMD;60ohm,4516,TP,70ohm/45MHz,82ohm	1	S.N.A
....4	T0568	3301-001145	BEAD-SMD;60ohm,4516,TP,70ohm/45MHz,82ohm	1	S.N.A
....4	T0568	3301-001145	BEAD-SMD;60ohm,4516,TP,70ohm/45MHz,82ohm	1	S.N.A
....4	T0568	3301-001145	BEAD-SMD;60ohm,4516,TP,70ohm/45MHz,82ohm	1	S.N.A
....4	T0568	3301-001145	BEAD-SMD;60ohm,4516,TP,70ohm/45MHz,82ohm	1	S.N.A
....4	T0568	3301-001145	BEAD-SMD;60ohm,4516,TP,70ohm/45MHz,82ohm	1	S.N.A
....4	CN330	3711-005503	HEADER-BOARD TO CABLE;BOX,9P,1R,2mm,SMD-	1	S.A
....4	CN330	3711-005509	HEADER-BOARD TO CABLE;BOX,4P,1R,1.25mm,S	1	S.A
....4	T0010	BN27-00009A	COIL CHOKE;SMD 12X12X6,EOS,33UH,15%,-,0.	1	S.A
....4	T0077	BN41-00772C	PCB MAIN;DOPPLER,CEM-3,2L,1.2.1.6,118*78	1	S.N.A
....4	MICOM	BN97-01361X	ASSY MICOM-ATZ,WW;M-HA20W9BGa-1002,(628	1	S.N.A
....5	IC115	1107-001561	IC-FLASH MEMORY;25VF010,128Kx8Bit,SOP,8P	1	S.N.A
....4	C314	2402-001310	C-AL,SMD;100nF,20%,35V,WT,TP,8X10mm	1	S.A
....4	SUB05	0202-001477	SOLDER-CREAM;LST309-M,-,D20-45\$,96.5Sn/	0.15	S.N.A
..2	M0006	BN96-04800A	ASSY SHIELD P-COVER;LS20HAW,SECC T1.0,4L	1	S.N.A
...3		BN61-02428D	STUD-PEM;PNA,M4,D8,L8,ZPC(SIL),SUM24L	4	S.N.A
...3		BN61-02429D	STUD-PEM;PNB,M2.8,D7,L20,ZPC(SIL),SUM24L	1	S.N.A
...3	M0001	BN63-01774A	SHIELD-INSULATOR;BI17/19BS,PET,T0.35	1	S.N.A
...3	M0107	BN63-03156A	SHIELD-COVER;LS20HAW,SECC,T1.0,4LAMP	1	S.N.A
..2	M2893	BN39-00785A	LEAD CONNECTOR;LS19PLMTSQ,UL1007#26,UL/C	1	S.A
0.1	M0113	BN92-01619X	ASSY P/MATERIAL;LS20HAWCBQ/XAA	1	S.N.A
..2	T0376	6902-000061	BAG AIR;LDPE,T0.2,L1000,W500,TRP,,,	0.014	S.N.A
..2	T0376	6902-000379	BAG AIR;LDPE,T0.2,W1000,L1800,TRP,-,-	0.002	S.N.A
..2	T0524	6902-000520	BAG PE;HDPE/NITRON(DOUBLE),T0.015/T0.5(D	1	S.N.A
..2	T0003	6902-000604	BAG WRAPPING;LDPE,T0.02,W500,L10000,TRP,	1.83	S.N.A
..2	M0081	6902-000609	BAG ROLL;LDPE,T0.05,W2400,L1000,TRP,-,-	0.026	S.N.A
0.1	M0045	BN92-01720S	ASSY ACCESSORY;LS20HAWCSQ/EDC	1	S.N.A
..2	M0114	BN39-00244B	CBF SIGNAL;MO15PS,15P/15P,20276-N,1830mm	1	S.A
..2	M0125	BN39-00246F	CBF SIGNAL-DVI(D);1703FP,24P/24P,20276-D	1	S.A
..2	M0045	BN96-03262T	ASSY ACCESSORY;LS20HAWCSQ/EDC	1	S.A
...3	T0268	3903-000042	CBF-POWER CORD;DT,EU,FP3/YES,IEC320 C13/	1	S.A
...3	T0524	6902-000110	BAG PE;LDPE,T0.05,W250,L400,TRP,28,2	1	S.N.A
...3	ACCESSORY	BH68-70448A	CARD-01;TFT LCD,SRG,RUSSIA,S/W,120,W210*	1	S.N.A
...3	ACCESSORY	BN68-00907A	MANUAL FLYER-01,CARD;COMM,SAMSUNG,18 LAN	1	S.N.A
...3	M0215	BN96-03059C	ASSY MANUAL P-IB+QSG;203BW,SyncMaster,W/	1	S.N.A
....4	QSG	BH68-00376L	MANUAL FLYER-06,QSG;LCDQUICK SETUP GUIDE	1	S.N.A

Level	Loc. No.	Code No.	Description & Specification	Q'ty	SA/SNA
...4	T0081	BN59-00509C	S/W DRIVER-06,IB;203BW,W/W,SyncMaster,Ha	1	S.NA
...3	ACCESSORY	BN68-01237A	MANUAL FLYER-QSG;COMM,W/W(L12),Mojo 100g	1	S.NA
...3	ACCESSORY	BH68-00633B	MANUAL FLYER-00,WARRANTY CARD;comm,Samsu	1	S.NA
...3	ACCESSORY	BN68-01118B	MANUAL-01,TCO03 CARD;COMM,W/W,Mojo 100g,	1	S.NA
0.1	M0003	BN92-01728D	ASSY BOX;LS20HAWCSQ/EDC	1	S.NA
..2	BOX	BN69-01356A	BOX-02,SET;LS20HAW_HAS,SY-03,A,YEL,A1,W5	1.02	S.NA
..2	T0081	BN96-02895A	ASSY MISC P-HANDLE PACKING;ALL MODEL,BN6	1	S.NA
...3	M0103	BN66-00007A	LEVER-TOP;ALL MODEL,LDPE,WHITE	1	S.NA
...3	M0102	BN66-00008A	LEVER-BOTTOM;ALL MODEL,LDPE,WHITE	1	S.NA
0.1		BN91-01303M	ASSY LCD-ATZ;LS20HAWCSZ*,4LAMP	1	S.NA
..2	M0215	BN07-00402A	LCD-PANEL;M201EW02 V8,Doppler,6bit Hi-FR	1	S.A
0.1	M0019	BN92-02921L	ASSY LABEL;LS20HAWCSQ/EDC	1	S.NA

6 Electrical Parts List

Memo

7 Block Diagram

Block Diagram

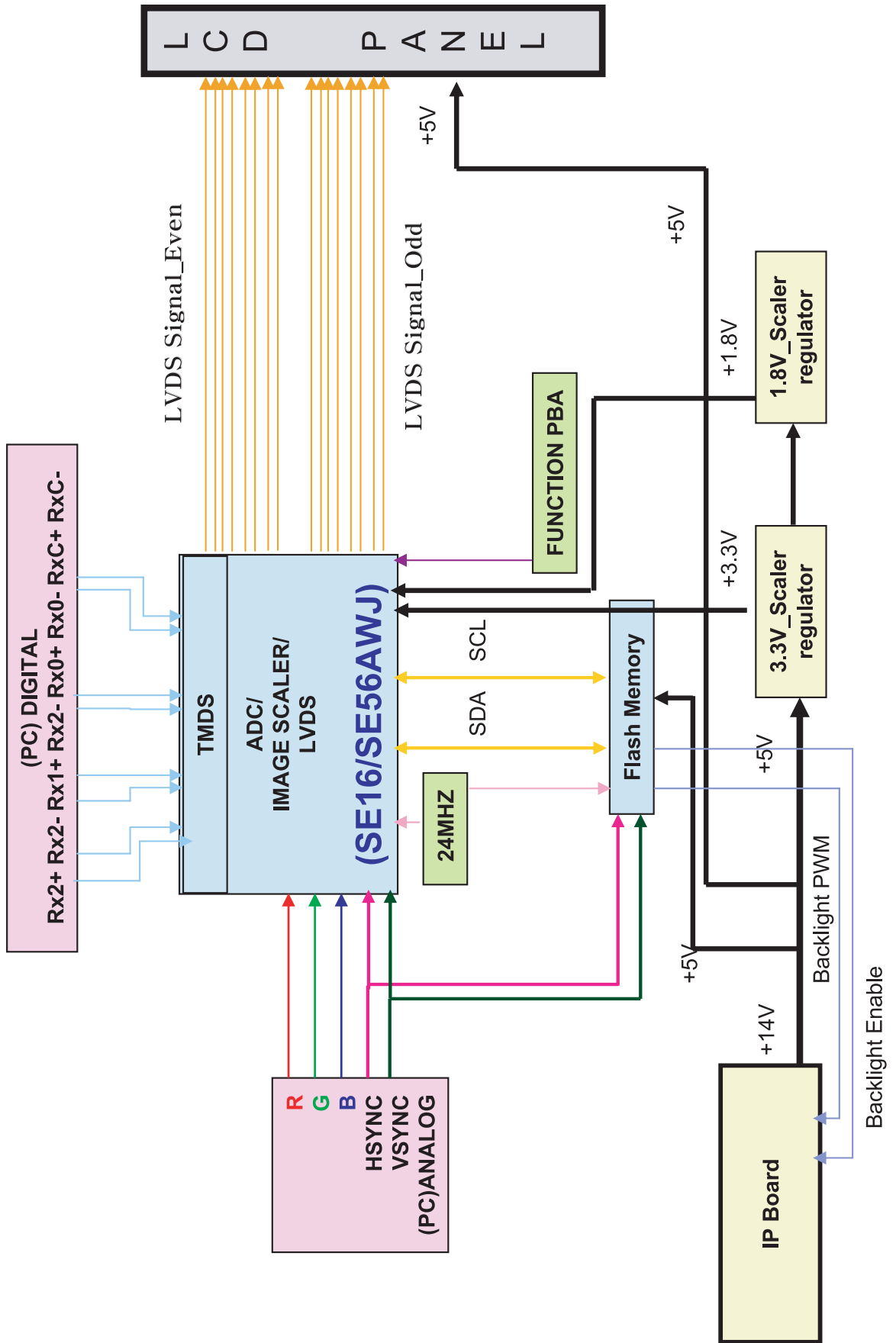

Power Flow

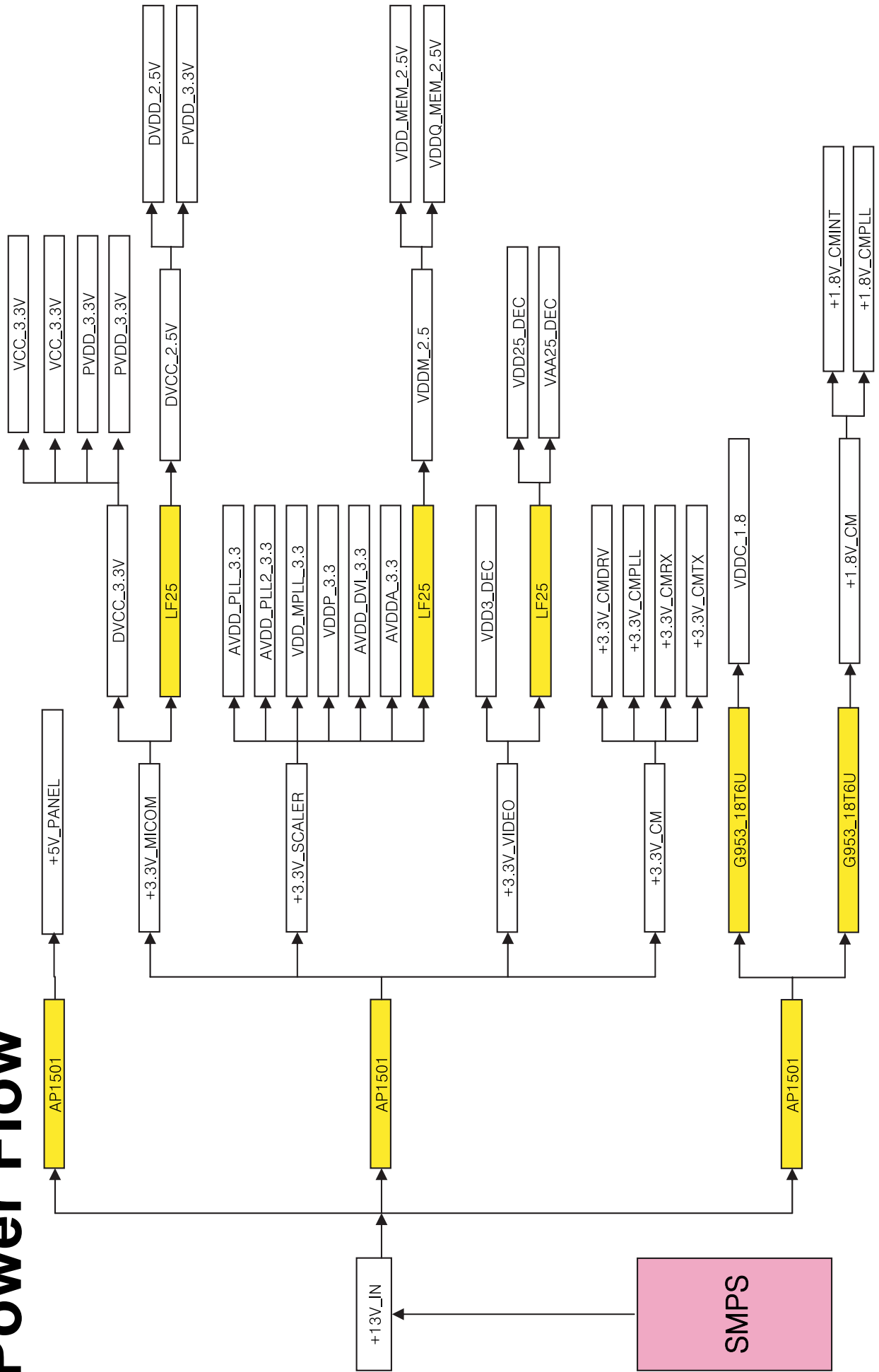

8 Wiring Diagram

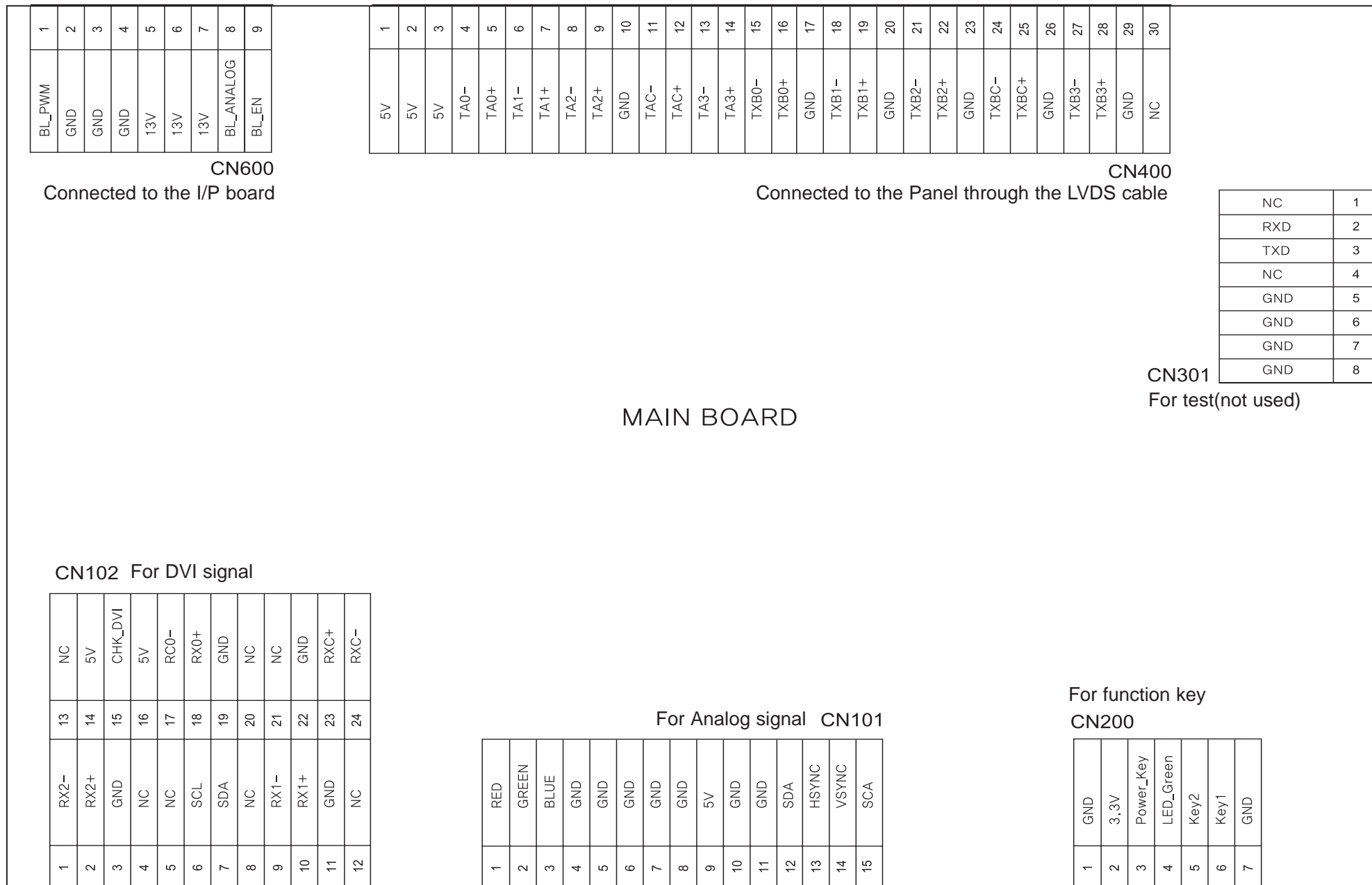

Memo

1 Precautions

Follow these safety, servicing and ESD precautions to prevent damage and to protect against potential hazards such as electrical shock.

1-1 Safety Precautions

1-1-1 Warnings

1. For continued safety, do not attempt to modify the circuit board.
2. Disconnect the AC power and DC power jack before servicing.

1-1-2 Servicing the LCD Monitor

1. When servicing the LCD Monitor, Disconnect the AC line cord from the AC outlet.
2. It is essential that service technicians have an accurate voltage meter available at all times. Check the calibration of this meter periodically.

1-1-3 Fire and Shock Hazard

Before returning the monitor to the user, perform the following safety checks:

1. Inspect each lead dress to make certain that the leads are not pinched or that hardware is not lodged between the chassis and other metal parts in the monitor.
2. Inspect all protective devices such as nonmetallic control knobs, insulating materials, cabinet backs, adjustment and compartment covers or shields, isolation resistor-capacitor networks, mechanical insulators, etc.
3. Leakage Current Hot Check (Figure 1-1):

WARNING : Do not use an isolation transformer during this test.

Use a leakage current tester or a metering system that complies with American National Standards Institute (*ANSI C101.1, Leakage Current for Appliances*), and Underwriters Laboratories (*UL Publication UL1410, 59.7*).

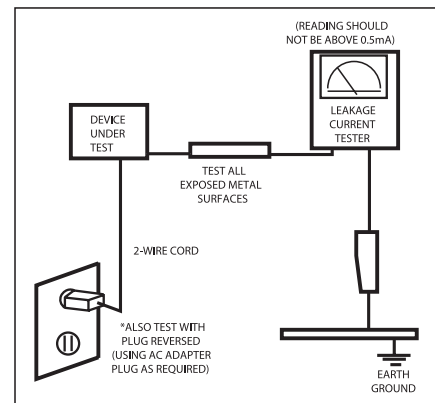

Figure 1-1. Leakage Current Test Circuit

4. With the unit completely reassembled, plug the AC line cord directly into a 120V AC outlet. With the unit's AC switch first in the ON position and then OFF, measure the current between a known earth ground (metal water pipe, conduit, etc.) and all exposed metal parts, including: metal cabinets, screwheads and control shafts. The current measured should not exceed 0.5 milliamp. Reverse the power-plug prongs in the AC outlet and repeat the test.

1-1-4 Product Safety Notices

Some electrical and mechanical parts have special safety-related characteristics which are often not evident from visual inspection. The protection they give may not be obtained by replacing them with components rated for higher voltage, wattage, etc. Parts that have special safety characteristics are identified by \triangle on schematics and parts lists. A substitute replacement that does not have the same safety characteristics as the recommended replacement part might create shock, fire and/or other hazards. Product safety is under review continuously and new instructions are issued whenever appropriate.

1 Precautions

1-2 Servicing Precautions

WARNING: An electrolytic capacitor installed with the wrong polarity might explode.

Caution: Before servicing units covered by this service manual, read and follow the Safety Precautions section of this manual.

Note: If unforeseen circumstances create conflict between the following servicing precautions and any of the safety precautions, always follow the safety precautions.

1-2-1 General Servicing Precautions

1. Always unplug the unit's AC power cord from the AC power source and disconnect the DC Power Jack before attempting to:
(a) remove or reinstall any component or assembly, (b) disconnect PCB plugs or connectors, (c) connect a test component in parallel with an electrolytic capacitor.
2. Some components are raised above the printed circuit board for safety. An insulation tube or tape is sometimes used. The internal wiring is sometimes clamped to prevent contact with thermally hot components. Reinstall all such elements to their original position.
3. After servicing, always check that the screws, components and wiring have been correctly reinstalled. Make sure that the area around the serviced part has not been damaged.
4. Check the insulation between the blades of the AC plug and accessible conductive parts (examples: metal panels, input terminals and earphone jacks).
5. Insulation Checking Procedure: Disconnect the power cord from the AC source and turn the power switch ON. Connect an insulation resistance meter (500 V) to the blades of the AC plug.
The insulation resistance between each blade of the AC plug and accessible conductive parts (see above) should be greater than 1 megohm.
6. Always connect a test instrument's ground lead to the instrument chassis ground before connecting the positive lead; always remove the instrument's ground lead last.

1-3 Electrostatically Sensitive Devices (ESD) Precautions

Some semiconductor (solid state) devices can be easily damaged by static electricity. Such components are commonly called Electrostatically Sensitive Devices (ESD). Examples of typical ESD are integrated circuits and some field-effect transistors. The following techniques will reduce the incidence of component damage caused by static electricity.

1. Immediately before handling any semiconductor components or assemblies, drain the electrostatic charge from your body by touching a known earth ground. Alternatively, wear a discharging wrist-strap device. To avoid a shock hazard, be sure to remove the wrist strap before applying power to the monitor.
2. After removing an ESD-equipped assembly, place it on a conductive surface such as aluminum foil to prevent accumulation of an electrostatic charge.
3. Do not use freon-propelled chemicals. These can generate electrical charges sufficient to damage ESDs.
4. Use only a grounded-tip soldering iron to solder or desolder ESDs.
5. Use only an anti-static solder removal device. Some solder removal devices not classified as "anti-static" can generate electrical charges sufficient to damage ESDs.
6. Do not remove a replacement ESD from its protective package until you are ready to install it. Most replacement ESDs are packaged with leads that are electrically shorted together by conductive foam, aluminum foil or other conductive materials.
7. Immediately before removing the protective material from the leads of a replacement ESD, touch the protective material to the chassis or circuit assembly into which the device will be installed.
Caution: Be sure no power is applied to the chassis or circuit and observe all other safety precautions.
8. Minimize body motions when handling unpackaged replacement ESDs. Motions such as brushing clothes together, or lifting your foot from a carpeted floor can generate enough static electricity to damage an ESD.

1-4 Installation Precautions

1. For safety reasons, more than two people are required for carrying the product.
2. Keep the power cord away from any heat emitting devices, as a melted covering may cause fire or electric shock.
3. Do not place the product in areas with poor ventilation such as a bookshelf or closet. The increased internal temperature may cause fire.
4. Bend the external antenna cable when connecting it to the product. This is a measure to protect it from being exposed to moisture. Otherwise, it may cause a fire or electric shock.
5. Make sure to turn the power off and unplug the power cord from the outlet before repositioning the product. Also check the antenna cable or the external connectors if they are fully unplugged. Damage to the cord may cause fire or electric shock.
6. Keep the antenna far away from any high-voltage cables and install it firmly. Contact with the highvoltage cable or the antenna falling over may cause fire or electric shock.
7. When installing the product, leave enough space (10cm) between the product and the wall for ventilation purposes.
A rise in temperature within the product may cause fire.

1 Precautions

Memo

Free Manuals Download Website

<http://myh66.com>

<http://usermanuals.us>

<http://www.somanuals.com>

<http://www.4manuals.cc>

<http://www.manual-lib.com>

<http://www.404manual.com>

<http://www.luxmanual.com>

<http://aubethermostatmanual.com>

Golf course search by state

<http://golfingnear.com>

Email search by domain

<http://emailbydomain.com>

Auto manuals search

<http://auto.somanuals.com>

TV manuals search

<http://tv.somanuals.com>