



User's Guide

User's Guide



Color All-in-One

SF-430

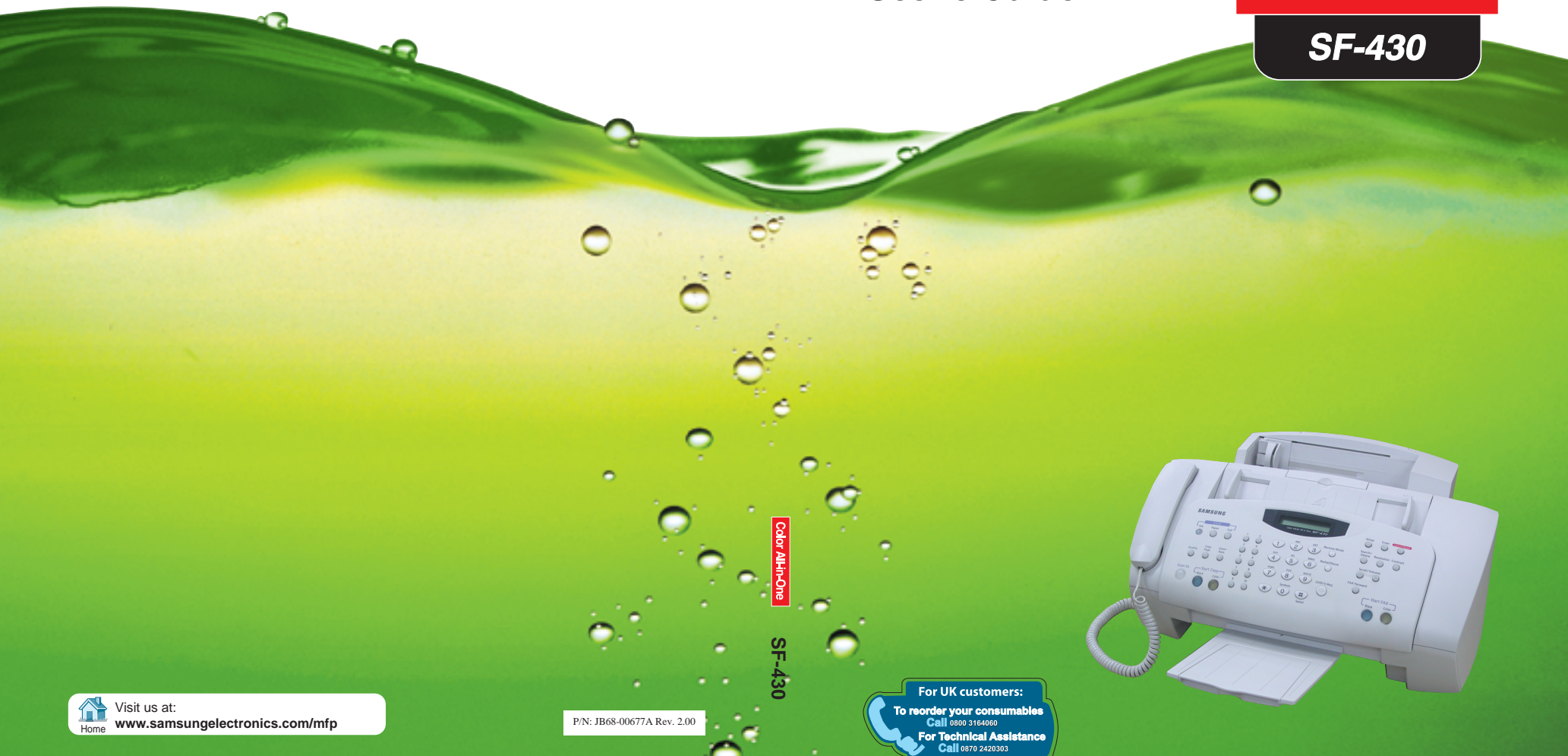

Color All-in-One

SF-430



Home Visit us at: www.samsungelectronics.com/mfp

P/N: JB68-00677A Rev. 2.00

For UK customers:
To reorder your consumables
Call 0800 3164060
For Technical Assistance
Call 0870 2420303

Important Precautions and Safety Information

When using this product, these basic safety precautions should always be followed to reduce risk of fire, electric shock, and injury to persons:

- 1** Read and understand all instructions.
- 2** Use common sense whenever operating electrical appliances.
- 3** Follow all warnings and instructions marked on the product and in the literature accompanying the product.
- 4** If an operating instruction appears to conflict with safety information, heed the safety information. You may have misunderstood the operating instruction. If you cannot resolve the conflict, contact your sales or service representative for assistance.
- 5** Unplug the product from the AC wall socket and/or telephone jack before cleaning. Do not use liquid or aerosol cleaners. Use only a damp cloth for cleaning.
- 6** Do not place the product on an unstable cart, stand, or table. It may fall, causing serious damage.
- 7** Your product should never be placed on, near, or over a radiator, heater, air conditioner, or ventilation duct.
- 8** Do not allow anything to rest on the power. Do not locate your product where the cords will be abused by persons walking on them.
- 9** Do not overload wall outlets and extension cords. This can diminish performance, and may result in the risk of fire or electric shock.
- 10** Do not allow pets to chew on the AC power, telephone, or PC interface cords.
- 11** Never push objects of any kind into the product through case or cabinet openings. They may touch dangerous voltage points, creating a risk of fire or shock. Never spill liquid of any kind onto or into the product.

- 12** Your product may have a heavy cover for optimal pressure on the document for the best scanning and/or faxing (usually the flatbed-type product). In this case, replace the cover after placing document on the scan glass, by holding and moving it down slowly until it seats on its location.
- 13** To reduce the risk of electric shock, do not disassemble the product. Take it to a qualified service technician when repair work is required. Opening or removing covers may expose you to dangerous voltages or other risks. Incorrect reassembly could cause electric shock when the unit is subsequently used.
- 14** Unplug the product from the telephone jack, PC and AC wall outlet, and refer servicing to qualified service personnel under the following conditions:
- When any part of the power cord, plug, or connecting cable is damaged or frayed.
 - If liquid has been spilled into the product.
 - If the product has been exposed to rain or water.
 - If the product does not operate properly after instructions have been followed.
 - If the product has been dropped, or the cabinet appears damaged.
 - If the product exhibits a sudden and distinct change in performance.
- 15** Adjust only those controls covered by the operating instructions. Improper adjustment of other controls may result in damage, and may require extensive work by a qualified service technician to restore the product to normal operation.
- 16** Avoid using this product during a lightning storm. There may be a remote risk of electric shock from lightning. If possible, unplug the AC power and telephone cord for the duration of the lightning storm.
- 17** SAVE THESE INSTRUCTIONS.

CONTENTS

1	SETUP	1.1
	Setting Up Your Product	1.2
	Choosing a Location	1.2
	Unpacking	1.2
	Contents	1.3
	Control Locations and Functions.....	1.4
	Front Panel Button Functions.....	1.6
	Setting Up Your product	1.8
	Loading Paper	1.11
	Installing the Print Cartridges	1.13
	Installing Software	1.19
	About Samsung Software	1.19
	System Requirements	1.20
	Installing Samsung Software.....	1.21
	Configuring the Fax Gate and Internet Gates	1.25
	Uninstalling Samsung Software	1.29
	Basic System Setup.....	1.34
	Setting Date and Time	1.34
	Setting Fax Number and Name	1.37
	Changing the Display Language	1.40
	Setting the Discard Size	1.40
	Setting Sounds.....	1.41
	Setting Dialling Mode	1.42
	Setting the PIN Code.....	1.43
	Setting the Handset Mode.....	1.44
	Setting Paper and Ink Save Modes.....	1.45

2	PRINT	2.1
	Paper Selection	2.2
	Loading Speciality Paper.....	2.4
	Printing a Document	2.6
	Printer Settings	2.8
	Using the Printer Control Program.....	2.18
3	COPY.....	3.1
	Setting Paper Size and Type.....	3.2
	Copying a Document.....	3.4
	Setting Copy Options	3.5
	Changing Default Settings	3.9
4	SCAN.....	4.1
	Scanning Basics	4.2
	Starting Scan from the Front Panel	4.2
	The Scanning Process with TWAIN-enabled Software	4.6
5	FAX.....	5.1
	Sending a Fax	5.2
	Preparing Documents for Faxing	5.2
	Adjusting Document Settings	5.3
	Loading Document.....	5.6
	Sending a Fax Automatically	5.7
	Sending a Fax Using Manual Dial	5.7
	Sending a Fax After Talking	5.8
	Cancelling a Fax	5.8
	Confirming Transmission	5.9
	Automatic Redial	5.9
	Redialling	5.10
	Voice Request	5.11
	Using the Toll Save Transmission.....	5.12

Receiving a Fax..... 5.14

About Reception Modes 5.14
Loading Paper for Receiving Faxes 5.15
Receiving Automatically in FAX Mode..... 5.16
Receiving in AUTO Mode 5.16
Receiving Automatically in ANS/FAX Mode..... 5.17
Receiving Manually in TEL Mode..... 5.18
Receiving Manually Using an Extension Telephone. 5.18
Receiving Using DRPD Feature..... 5.19
Receiving in Colour 5.19
Receiving Fax in Memory 5.19
Forwarding Received Faxes 5.20

Automatic Dialling 5.22

One-Touch Dialling 5.22
Speed Dialling 5.23
Group Dialling 5.25
Searching for a Number in the Memory 5.27

Advanced Faxing..... 5.28

Broadcasting 5.28
Delayed Fax..... 5.29
Priority Fax 5.31
Polling..... 5.32
Adding Documents To a Scheduled Operation 5.34
Cancelling a Scheduled Operation 5.35

Additional Feature 5.36

Printing Reports 5.36
Fax Setup Options 5.38
Using the Fax Settings Utility 5.44

6	MAINTENANCE	6.1
	Maintaining Print Cartridges	6.2
	Viewing Ink Levels	6.3
	Cleaning the Print Cartridges.....	6.3
	Replacing the Print Cartridges	6.10
	Aligning the Print Cartridges.....	6.16
	Clearing Memory	6.19
	Adjusting Shading	6.20
	Setting the Product to be Checked by Phone	6.20
	Cleaning the Document Scanner	6.21
7	TROUBLESHOOTING	7.1
	Clearing Jams	7.2
	LCD Error Messages	7.6
	Fixing Problems.....	7.9
8	APPENDIX	8.1
	Printer Specification	8.2
	Scanner and Copier Specification	8.2
	Fax Specification	8.3
	General Specification	8.4
	Paper Specification	8.5

INDEX

1

SETUP

Thank you for purchasing the Samsung SF-430 InkJet all in one. This multifunctional product provides printing, copying and scanning functions!

This chapter provides step-by-step instructions on setting up the product, and installing the software.

The chapter includes:

- **Setting Up Your Product**
- **Installing Software**
- **Basic System Setup**

Setting Up Your Product

Choosing a Location

To help guarantee trouble-free operation of your product, place it on a flat, stable surface near your workstation. Leave enough space to allow for easy paper loading, paper out and opening the top cover.

Do not place your product:

- In direct sunlight.
- Near heat sources or air conditioners.
- In dusty or dirty environments.

Unpacking

Unpack your product from the packing box, and check if anything is missing or damaged. Remove the shipping tapes from the front, back, and sides of the product.

Contents

Here is what is supplied with your product.

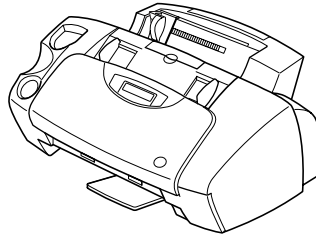

SF-430

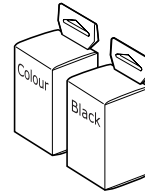

Colour and Black ink cartridges

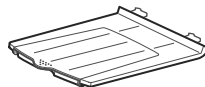

Document output support

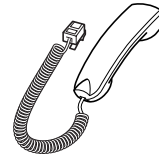

Handset

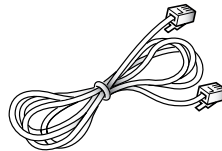

Telephone line cord^a

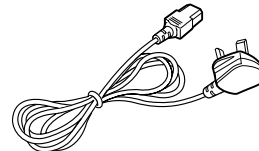

Power cord^a

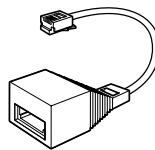

TAM lead

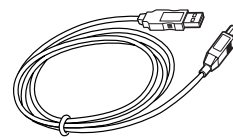

USB cable



**Software CD-ROM,
User's Guides**

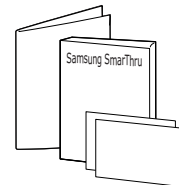

**SmarThru User's Guides,
Warranty cards, Quick Install Guide**

a. The shape of the cord plug may differ depending on your country.

Control Locations and Functions

Take a moment to familiarize yourself with the main components of your product.

Front View

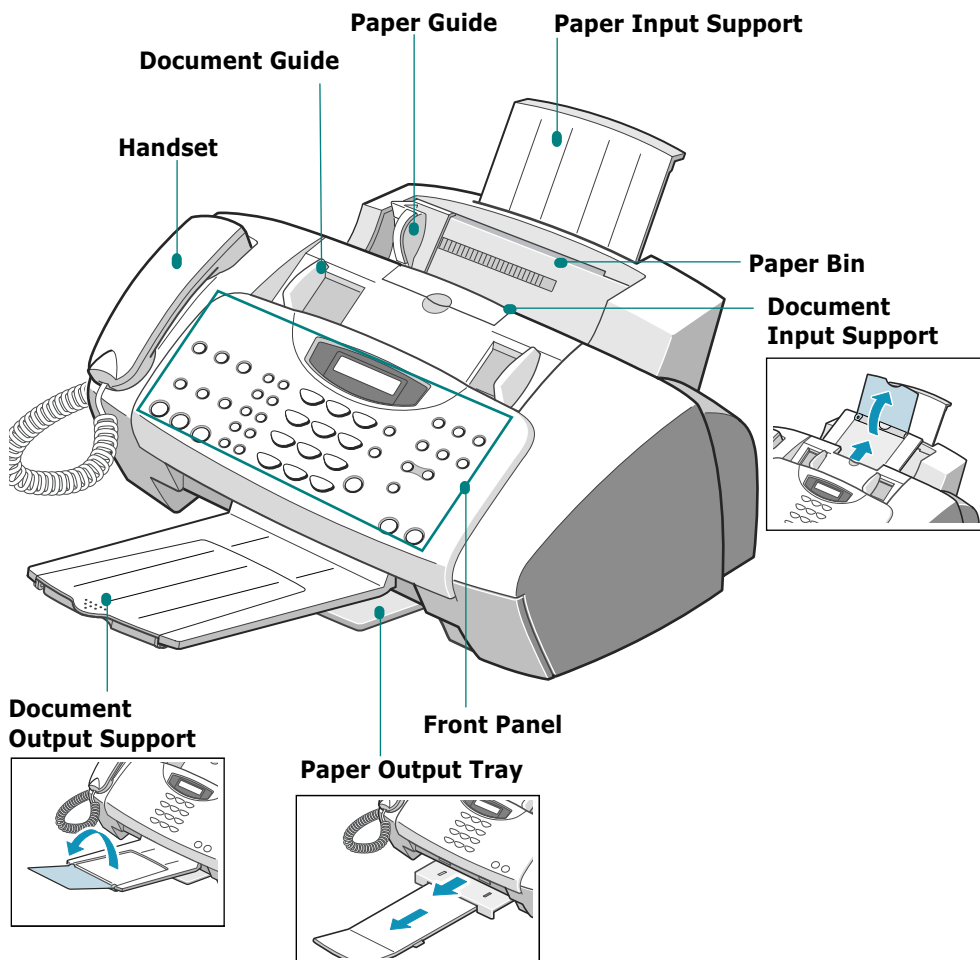

Inside

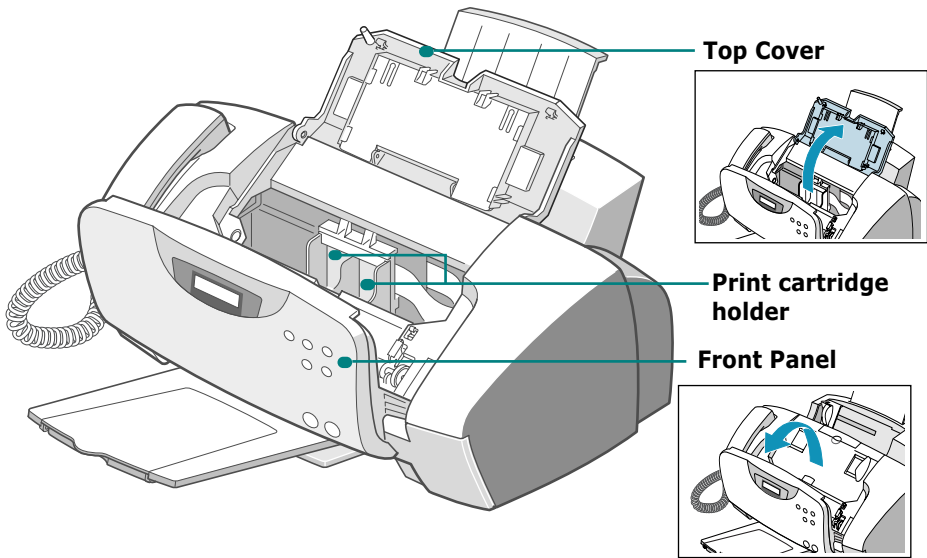

Rear

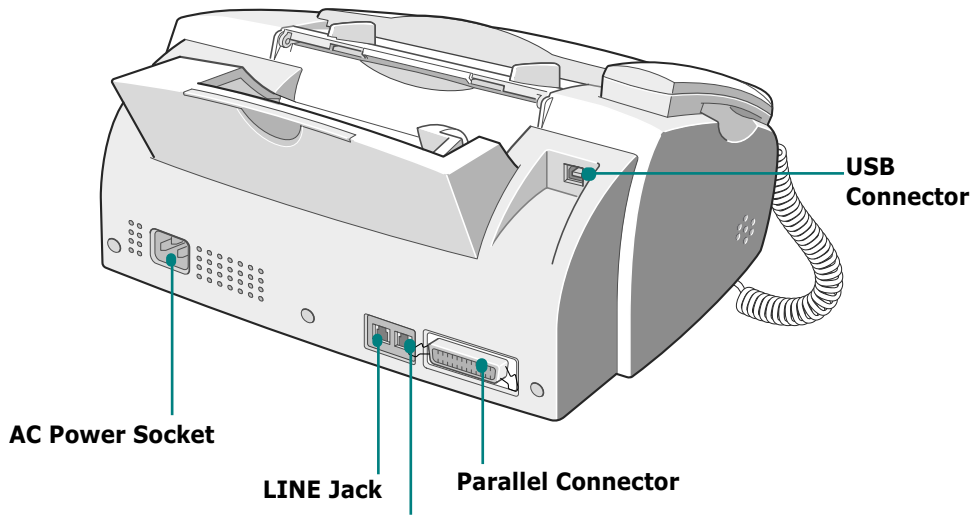





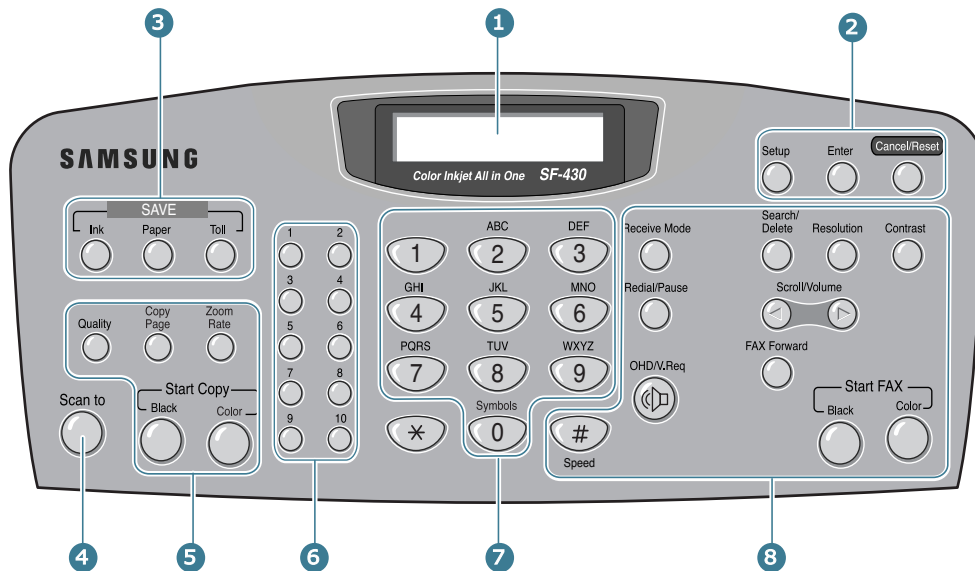













If your country has a different telephone connection system, this socket may be blocked.

Front Panel Button Functions



1		Displays current status and prompt during operation.
2		Enters menu mode.
		Confirms the selection on the display.
		Cancels a current operation including PC printing or resets the copy and fax setting item (Quality, Copy Page, Zoom Rate, Resolution, or Contrast) to its default setting.
3		Allows you to save ink by up to a maximum of 50% by printing images lighter (available in PC print, Copy and Fax receiving mode).
		Allows you to save paper by printing 2 pages on a single sheet of paper (available in Black and White Fax receiving and Copy mode only).
		Allows you to save on faxing costs by sending a fax at a preset time. By using this feature, you can take advantage of lower long distance rates at night, for example (only available in fax sending).
4		Launches Samsung ScanWizard in the desktop window from which you can select the scan destination.

1.6 SETUP

5		Adjusts the copy quality.
		Selects the number of copies.
		Makes a copy smaller or larger than the original.
		Makes a black and white copy.
		Makes a colour copy.
6		Stores frequently dialed fax numbers and dials them with a touch of the buttons.
7		Dials a number or enter alphanumeric characters.
8		Selects the receive mode. The selected mode is displayed in Standby mode.
		Searches for a number in memory. Also use to delete digits in the edit mode.
		Adjusts the resolution of the documents for the current fax job.
		Adjusts the contrast of the documents for the current fax or copy job.
		Redials the last number you dialed or received, and inserts a pause into a fax number.
		Scrolls through the menu items. Also used to adjust the volume.
		Engages the telephone line. Also used to reserve a voice call during fax transmission or reception.
		Sets your product to forward incoming faxes to another fax number.
		Stores frequently dialed fax numbers and dial them using a 2-digit speed number.
		Starts to send a black and white fax.
		Starts to send a colour fax.

Setting Up Your product

Document Input Support

Pull the document input support upward. Fold out the extender, if necessary.

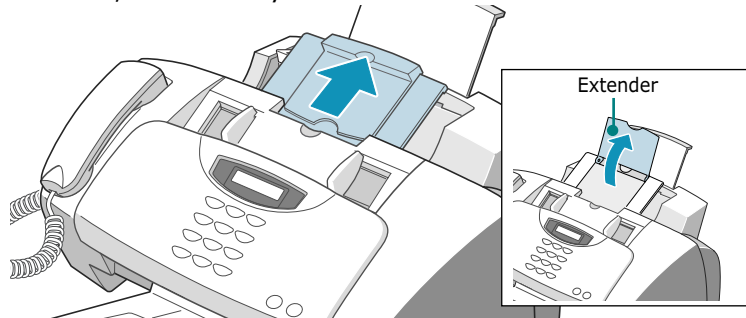

Document Output Support

Insert the two tabs on the document output support tray into the slots on the front of your product. Fold out the extender, if necessary.

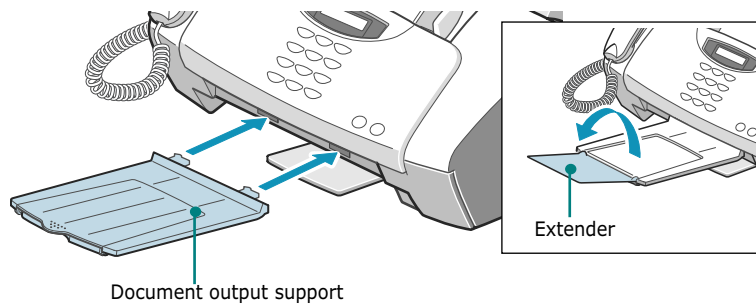

Handset

Plug the end of the handset line into the jack at the bottom of the product, and fix the line into the latch.

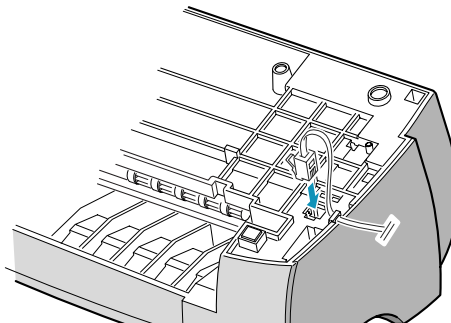

Telephone Line

Plug one end of the supplied telephone line cord into the **LINE** jack socket and the other end into a standard phone wall jack socket.

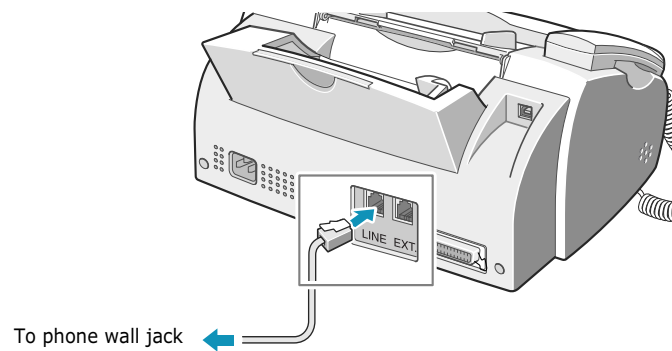

NOTES:

- This product is intended for connection to analogue telephone networks in the United Kingdom.
- It is strongly recommended that you use the TAM lead and telephone line cord supplied with your machine.
- If you are using the line cord with the other manufacturer's, it should be AWG #26 or lower gauge. Note that the product may not operate correctly.

Extension Phone

If you want to use a regular phone or answering machine with your product, connect the phone into the **EXT** jack.

Plug the cord of your extension phone or answering machine into the TAM lead and the TAM lead into the socket marked **EXT** on the back of your product.

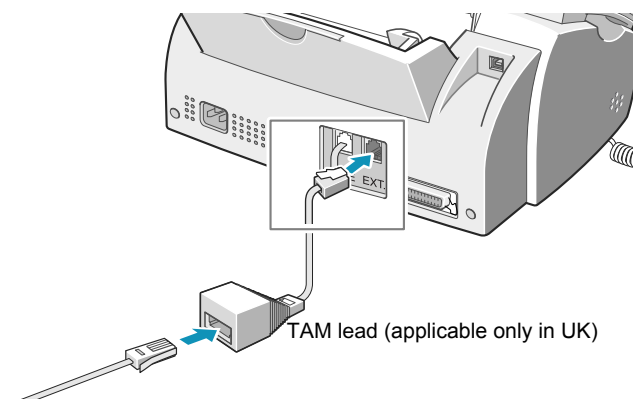

Printer Cable

Connect the printer cable into the connector on the back of the product. Then, connect the other end of the cable to the corresponding port on your computer.

Use either USB cable which come with your product or IEEE-1284 compliant parallel cable (purchased separately).

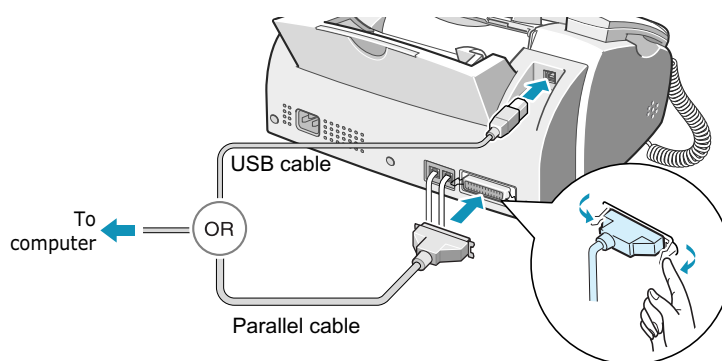

NOTES:

- If using a USB cable, you must be running Windows 98/Me/2000/XP.
- Shut down your computer before connecting the cable.
- When using USB connection, your product provides two USB modes: Fast and Slow. Fast is the default mode. Some PC user may experience poor USB implementation in the default mode. If this occurs, select Slow mode to achieve successful results. For details on changing the USB mode, see page 7.14.

AC Power Cord

Plug one end of the cord into the back of the product and the other end into a standard grounded AC power outlet.

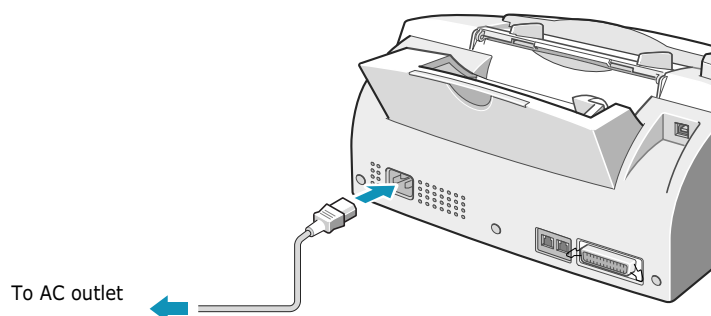

As you plug it in, your product will turn on. 'POWERING UP PLEASE WAIT' appears on the display indicating the product is on. To view your display text in another language, see page 1.40.

If you want to turn it off, unplug the power cord.



NOTE: When you first set up the product, you see "CHECK CARTRIDGES" on the display. Load paper (see page 1.11), then install the print cartridges (see page 1.13).

Loading Paper

The display shows "ADD PAPER THEN PRESS ENTER" if no paper is loaded starting to print a job. The paper bin will hold approximately 100 sheets of 20 lb plain paper.

In the Fax or Copy mode, you can use A4-, letter-, or legal-size paper.

To load plain paper, take the following steps:

- 1** Pull the paper support on the paper bin all the way up.

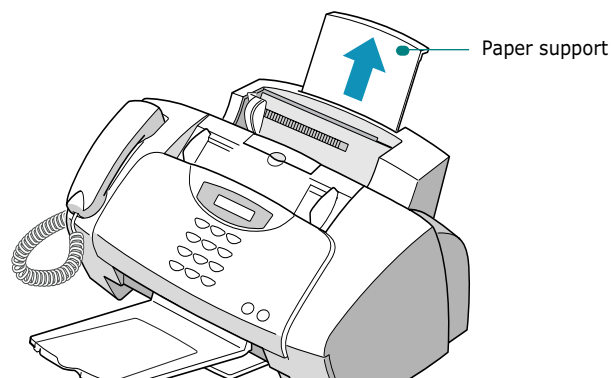

- 2** Fan the paper and then insert it into the paper bin with the print side facing you. Ensure that the right edge of the paper is in contact with the right side of the paper bin. Do not exceed the specified capacity.

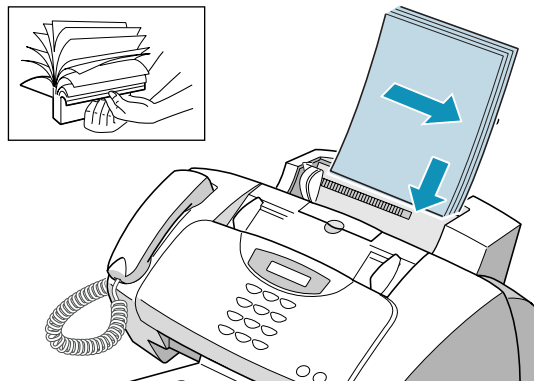

- 3** Squeeze the paper guide and move it to the right to match the width of the paper.

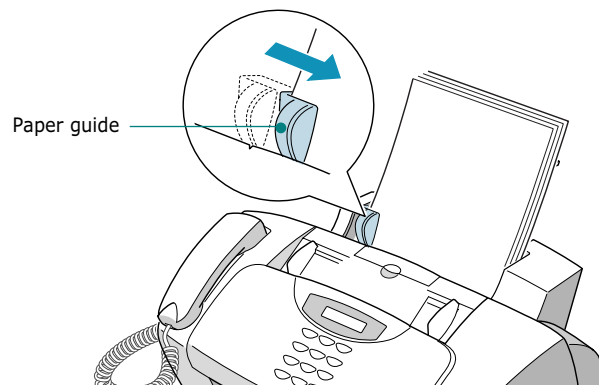

- 4** Pull the output tray and the output tray extender on the front of the product all the way out.

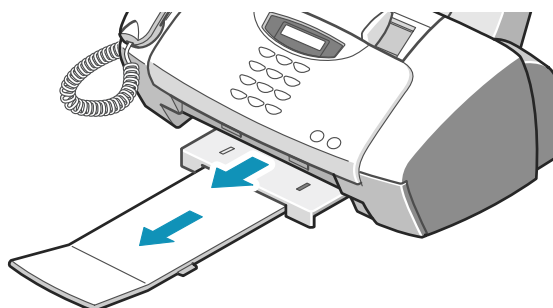

**NOTE:**

- Do not force the paper down into the printer.
- To ensure proper paper feeding, it is recommended that you load a stack of paper (more than 20 sheets).
- If you are using legal-size paper, do not pull the output tray out. Push it in, or it may cause a paper jam when the paper prints out.
- After loading paper, you have to set your product for the paper size you have used. For details, see page 3.2 for copy job, page 5.39 for fax job and page 2.10 for PC printing job.

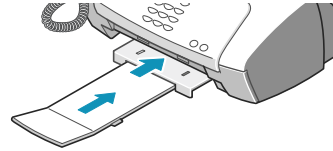

Installing the Print Cartridges

Your product comes with a black and a colour cartridge. You can purchase an optional photo cartridge and install it instead of the black cartridge. See page 1.18 for the options you can purchase.

Use this procedure when installing print cartridges for the first time. To install replacement print cartridges, see "Replacing the Print Cartridges" on page 6.10.



NOTE: There are two types of black and colour cartridges: Standard and high yield. Before proceeding to install, you need to check which cartridge type you have. When installing the cartridges, you will be asked if it is Standard or High Yield. To find out the type, please refer to the table on page 6.10.

- 1** Unwrap and remove the black print cartridge from the plastic bag. Hold the print cartridge at the top. Do not touch the electrical contacts.

Carefully remove the sealing tape covering the print head.

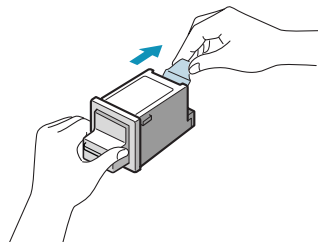

- 2** Lift the front panel by grabbing the panel along the top edge and pulling it towards you.

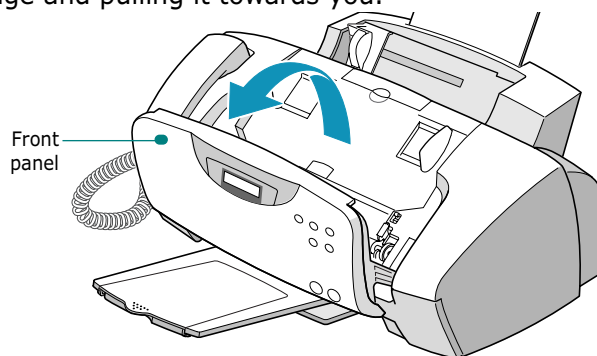

- 3** Open the top cover.

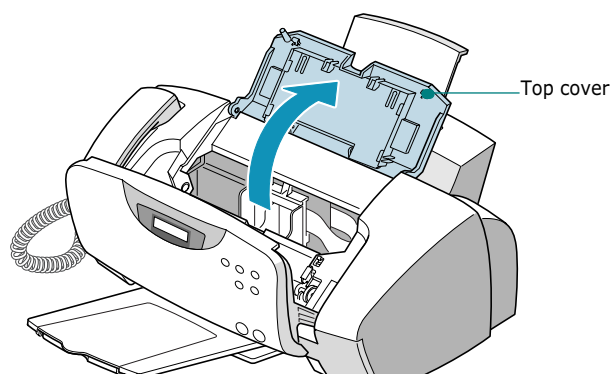

4 The cartridge holder moves to the install position.

The colour cartridge will be inserted into the left side of the cartridge holder and can be identified by a yellow tab on the top of the holder.

The black (or photo) cartridge will be inserted into the right side of the cartridge holder and can be identified by a green tab on the top of the holder.

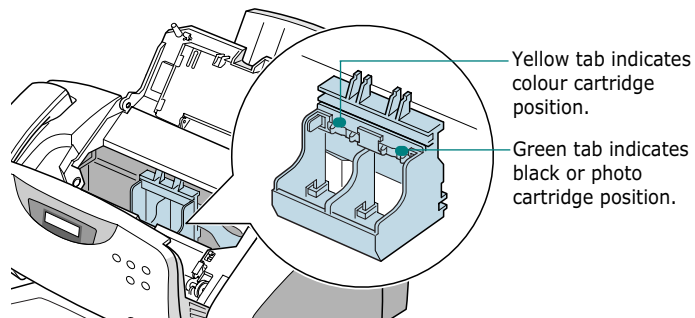

5 Insert the black print cartridge into the right side of the holder.

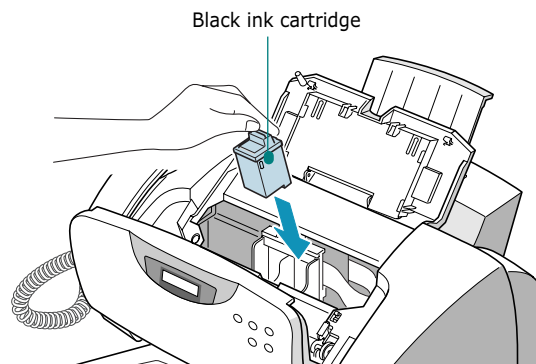

6 Push the black cartridge back until it clicks into place.

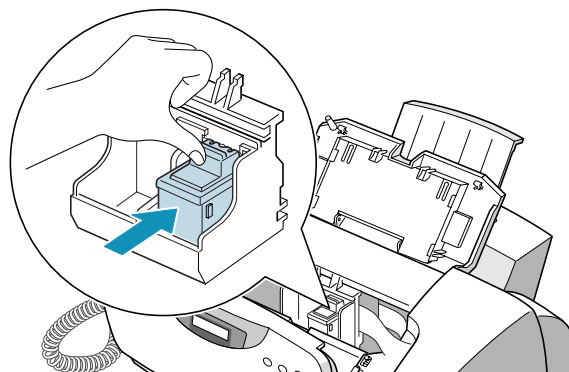

- 7** Unwrap and remove the colour print cartridge from the plastic bag. Holding the cartridge at the top, carefully remove the sealing tape.
- 8** Insert the colour print cartridge from the print head into the left side of the holder.

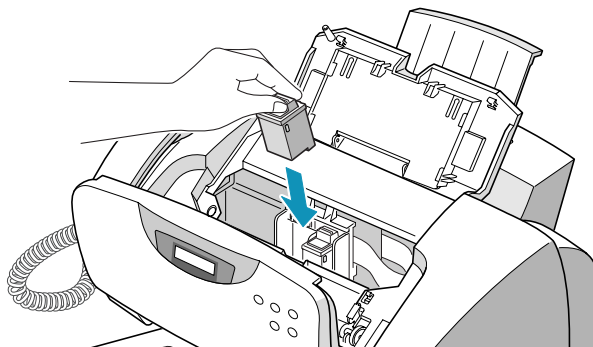

- 9** Push the colour print cartridge back until it clicks into place.

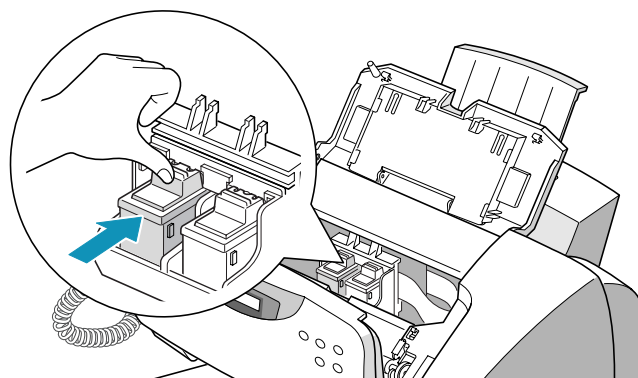

- 10** After installing the print cartridges, close the cover and replace the front panel.



NOTES: If the display shows "REMOVE PAPER JAM AND PRESS CANCEL" when you have closed the front panel, re-install the cartridge(s). With the print cartridge(s) installed improperly, the product might not print.

- 11** When you have closed the covers, the display prompts you to confirm 'CARTRIDGE CHANGED? NO'. Press the **Scroll** buttons (◀ or ▶) until you see 'BOTH' in the bottom right corner of the display and then press **Enter**.

- 12** The display shows 'LEFT CARTRIDGE NEW COLOR'. Press **Enter** to confirm you have installed a new colour cartridge.
- 13** The display shows 'LEFT CARTRIDGE STANDARD COLOR'. Press **Enter** to confirm you have installed a standard capacity cartridge. If not, press the **Scroll** buttons (◀ or ▶) to display 'LEFT CARTRIDGE HIGH YIELD COLOR' and then press **Enter**.
- 14** The display shows 'RIGHT CARTRIDGE NEW BLACK'. Press **Enter** to confirm you have installed a new black cartridge.
- 15** The display shows 'RIGHT CARTRIDGE STANDARD BLACK'. Press **Enter** to confirm you have installed a standard capacity cartridge. If not, press the **Scroll** buttons (◀ or ▶) to display 'RIGHT CARTRIDGE HIGH YIELD BLACK' and then press **Enter**.
- 16** The cartridge holder returns to the home position. The Cartridge Alignment procedure begins automatically by printing an Alignment Test Form.

Use this test form to identify the straightest line in each of six alignment areas. By selecting the straightest line for each pattern, you will optimise the print head alignment.

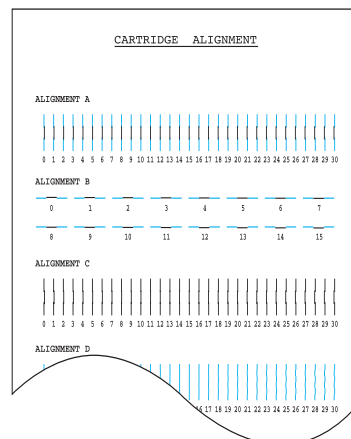

- 17** Looking at your Alignment Test Form, identify the straightest line in Alignment A.

Using the number keypad, enter the two digit number of your straightest line and then press **Enter**.

SETUP

1.17

18 The display accepts your number and moves to alignment B. Repeat step 16 for alignment patterns B-F.

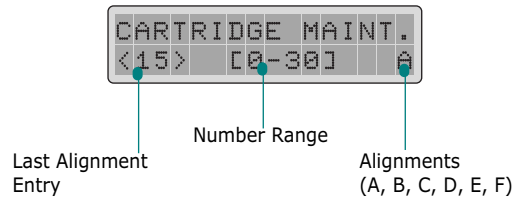

19 When you finish entering the number for alignment pattern F, the display returns to Standby mode.



NOTES:

- When either print cartridge starts to run out of ink, replace the empty print cartridge. With an empty print cartridge or only one print cartridge installed, the product will print but the print quality will be reduced.
- Keep a spare print cartridge on hand. When buying print cartridges, check the part numbers referenced below to ensure buying the correct print cartridge. These print cartridges have been specifically designed to work with your product to produce results that are always clear and sharp.
- If you want to purchase a new print cartridge, either contact your point of purchase or any Lexmark authorized supplies dealer.

Cartridge type		Part number
Black cartridge	High yield	Lexmark 12A1975
	Standard	Samsung INK-M50 Lexmark 12A1970
Colour cartridge	High yield	Lexmark 15M0125
	Standard	Samsung INK-C60 Lexmark 15M0120
Photo cartridge		Lexmark 12A1990

Installing Software

1

About Samsung Software

You must install the SmarThru CD-ROM after you have set up your product and connected it to your computer. The SmarThru CD-ROM includes the following:

- MFP Driver
- SmarThru Software
- OCR Software (AnyPage Lite)

MFP Driver

To use your SF-430 as a printer and scanner, you must install the MFP driver.

SmarThru Software

SmarThru is the accompanying software for your SF-430 multifunctional product. SmarThru contains a powerful image editor that allows you to edit images in many ways and also includes powerful Internet mail client software. With SmarThru, you can save the scanned images in a dedicated storage area for subsequent editing, sending via e-mail or fax, printing, and processing by other programs of your choice.

OCR Software (AnyPage Lite)

OCR (Optical Character Recognition) is software that has the ability to recognize most character formats, so that a scanned document can be read and edited with word processing software.

System Requirements

Before you begin, ensure your system meets these minimum requirements.

Supported Operating System

Windows 95 OSR2/Windows 98/Windows 98 SE/Windows Me/Windows NT 4.0 Workstation or Server with Service Pack 3/Windows 2000 Professional or Advanced Server/Windows XP Home edition or Professional.

Minimal Requirements

- **Disk space:** 130 MB for installation
- **Memory:** 64 MB
- **CPU:** Pentium II 233 or higher
- **Required software:** Internet Explorer 4.01 or later.

Recommended

- **Disk space:** 250 MB for installation
- **Memory:** 128 MB
- **CPU:** Pentium II 400 or higher
- **Required software:** Internet Explorer 5.5 or later



NOTES:

- Administrative rights should be set for installation on Windows NT 4.0/2000/XP.
 - Windows 95 versions prior to OSR2 are not recommended due to compatibility with OLE/COM libraries.
-

Installing Samsung Software



NOTES:

- For Windows 95/98/Me/2000/XP users, cancel the "New Hardware Found" screen when the computer boots up.
- Make sure that your SF-430 is plugged in and connected to your computer's USB or parallel port **before installing software** from the CD. Windows 95 and Windows NT 4.0 do not support USB connection.

- 1** Insert the supplied SmarThru CD-ROM into your CD-ROM drive.

The SmarThru CD-ROM should automatically run and the opening window appears.

If the opening window does not appear, click **Start**, and then **Run**. Type **X:Autorun**, replacing "X" with the letter of your drive, and click **OK**.

If you are asked to select the language, choose the desired language.

- 2** Click **Install the Samsung Software on your PC**.

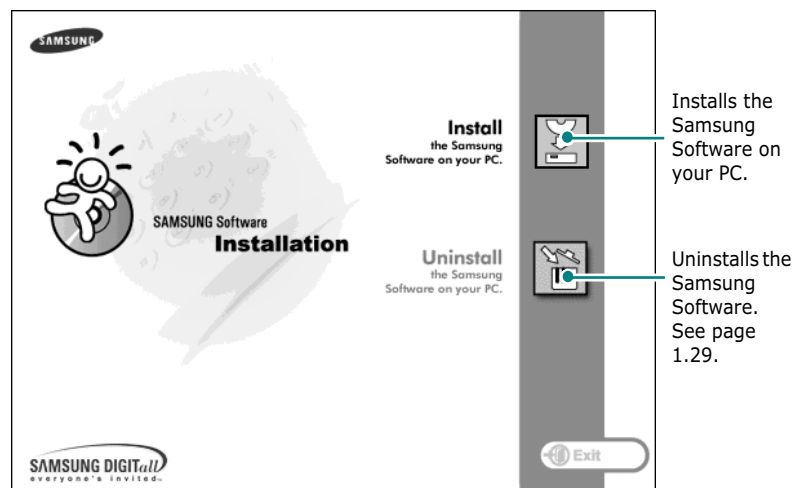

- 3** After reading, click **Next**.

- 4 Follow the on-screen instructions and click **Next**.
- 5 The SmarThru installation supports three types of setup:
 - **Typical:** Program will be installed with the most common options and is recommended for most users.
 - **Compact:** Only the MFP driver will be installed.
 - **Custom:** You may choose the options you want to install. Recommended for advanced users.

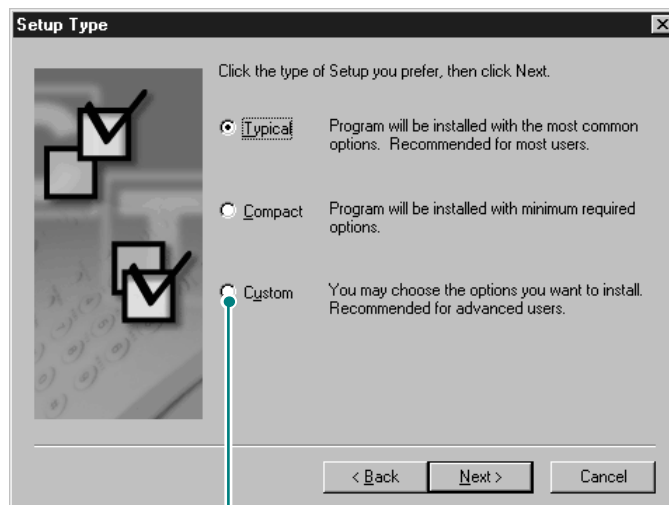

If you select the Custom installation, you may choose the options you want to install.

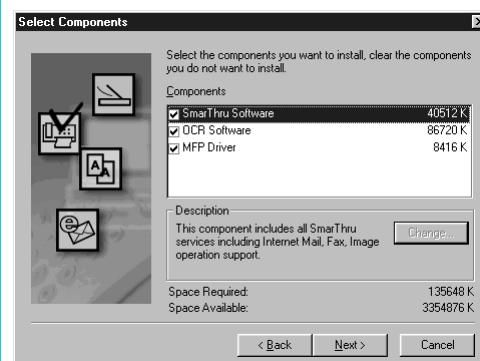

- **SmarThru Software:** to scan and edit images and work with electronic documents.
- **OCR Software:** AnyPage Lite software to enable OCR.
- **MFP Driver:** to print and scan.

- 6 Click **Next**.

- 7 You can choose the SmarThru networking option. This feature allows you to share the modems on your computer and the scan device SF-430 via a network or to access these shared devices located on other computers.

Stand-alone configuration does not allow you to use any networking features such as Remote Fax or Remote Scan service.

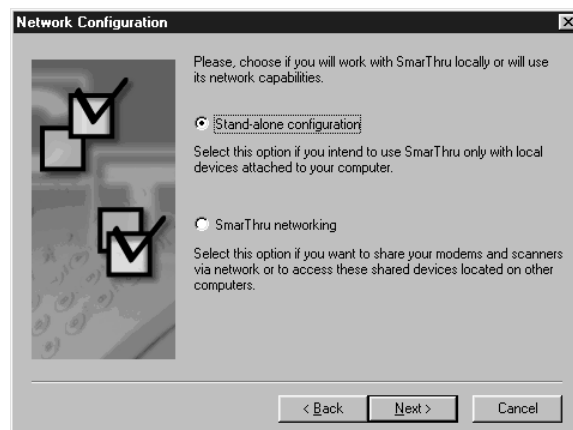

If you selected **SmarThru networking**, you can select to install server, client, or both.

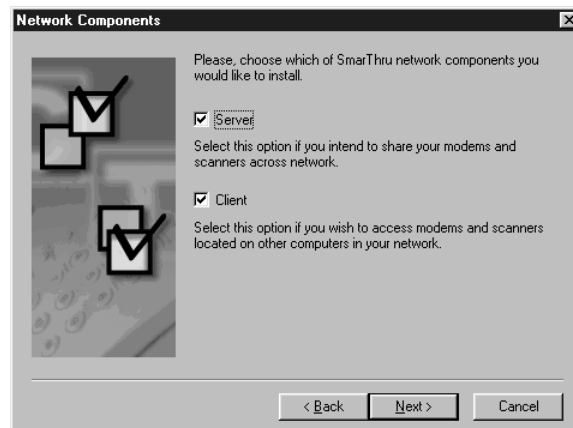

Server allows you to share a local fax modem and/or scanner over a LAN. You can control sharing by managing remote service users. **Client** allows you to use Remote Fax or Remote Scan services provided by a SmarThru Remote Services Server over a LAN. You need to have a client account. These accounts are provided by the server. For details on Remote Fax/Scan Services, please refer to the SmarThru User's Guide.

8 Click **Next**.

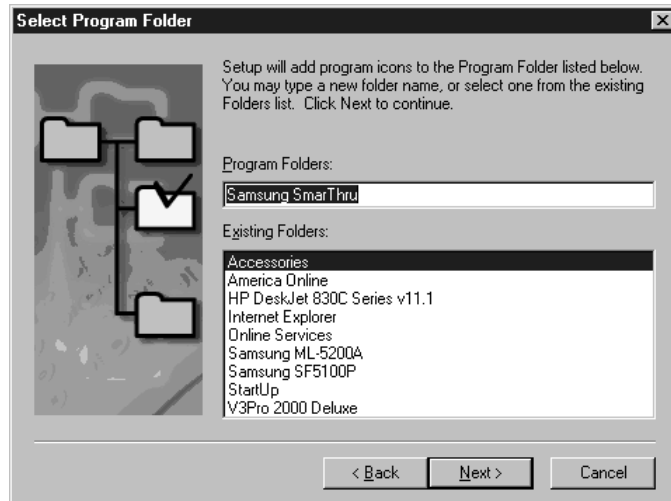

9 When the installation is completed, shut down and restart your computer.

If your computer does not shut down and restart automatically, you must shut it down manually and restart it before the changes will be effective.



NOTE: When you install the software, the Digital Signature Not Found window may appear in Windows 2000 and Windows XP. Click **OK** in Windows 2000 and click **Continue Anyway** in Windows XP.

Configuring the Fax Gate and Internet Gates

If you select **SmarThru networking Server** option (see page 1.23), when your computer restarts after the Samsung software has installed, you will be prompted to configure the fax and Internet gates allowing you to send and receive faxes and e-mails on the SmarThru system.

If you select the **Stand-alone** or **SmarThru networking Client** option (see page 1.23), the following wizards appear only the first time you try to launch Mailbox in the SmarThru program. For information on SmarThru, please refer to the SmarThru User's Guide.)



NOTE: To configure the Internet gate, you must enter your e-mail address, incoming (POP3 or IMAP4) and outgoing (SMTP) mail server address, and account name. Ask your Internet service provider or on-line service provider for the information on your Internet gate configuration.

- 1 When the New Modem Wizard appears, choose the modem installed in your system and then click **Next**. This fax modem will be used by SmarThru Fax Gate for sending and/or receiving faxes.

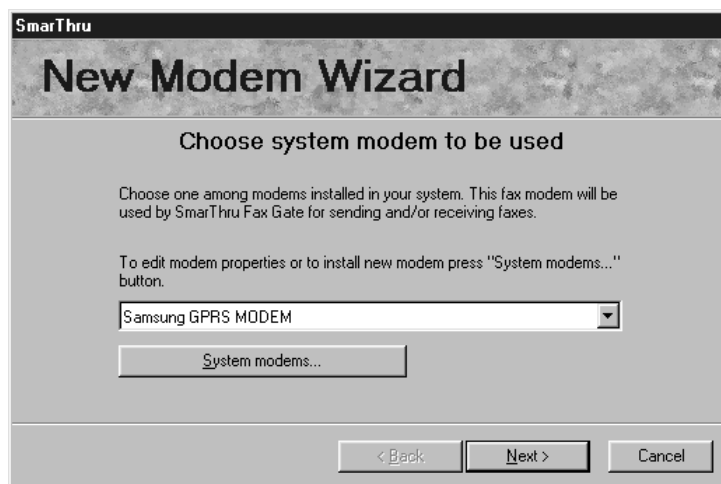

- 2 Click **Finish** to save the modem setting.

- 3 Enter your name and e-mail address, and click **Next**. The e-mail address has been assigned to you by your Internet service provider.

The screenshot shows a window titled "SmarThru" with a header "New Mail Account Wizard". The main heading is "Internet E-Mail Address". Below this, there are two input fields. The first is labeled "Enter your name:" and contains the text "buriniMe". Below it is an example: "For example: John A. Smith". The second input field is labeled "Enter your e-mail address:" and is empty. Below it is an example: "For example: mailbox@company.com". A note at the bottom states: "Note: Your e-mail address is the address other people use to send e-mail messages to you. This address has been assigned to you by your Internet service provider." At the bottom right, there are three buttons: "< Back", "Next >", and "Cancel".

- 4 Enter the addresses of your incoming and outgoing mail servers. Choose the incoming mail server type, then click **Next**. Your Internet service provider will be able to provide you with this information.

The screenshot shows a window titled "SmarThru" with a header "New Mail Account Wizard". The main heading is "E-Mail Server Addresses". Below this, there is a prompt: "Type the addresses of your incoming and outgoing mail servers." There are two input fields. The first is labeled "Incoming (POP3 or IMAP4) mail server address:" and is empty. Below it is an example: "For example: company.com". The second input field is labeled "Outgoing (SMTP) mail server address:" and is empty. Below it is an example: "For example: company.com". To the right of the second input field is a dropdown menu labeled "Incoming mail server protocol type:" with "POP3" selected. At the bottom right, there are three buttons: "< Back", "Next >", and "Cancel".

- 5 Enter your account name and password to access your Internet mail server, and click **Next**. Your Internet service provider will be able to provide you with this information.

The screenshot shows a dialog box titled "SmarThru" with the main heading "New Mail Account Wizard". The sub-heading is "Incoming mail server". Below this, there is a paragraph of instructions: "Please type your POP3 or IMAP4 account user name and password to access your Internet mail server. Your Internet service provider must give you this information." There are two input fields: "Account user name:" with the text "bruce999" and "Password:" with asterisks "*****". A note below the password field says "(Your password will appear in asterisks to prevent others from reading it.)". At the bottom, there are three buttons: "< Back", "Next >", and "Cancel".

- 6 Enter an account name, and click **Next**.

The screenshot shows a dialog box titled "SmarThru" with the main heading "New Mail Account Wizard". The sub-heading is "Account record name". Below this, there is a paragraph of instructions: "Please type account record name. This name will be used to refer it in Internet Gate Configuration and any incoming mail information notifications." There is one input field labeled "Account name:" with the text "chollian". At the bottom, there are three buttons: "< Back", "Next >", and "Cancel".

- 7 Click **Finish** to quit the wizard and enable the Internet e-mail service.



NOTE: If you wish, you can reconfigure the Internet gate later by using SmarThru Configuration. For details, refer to the SmarThru User's Guide.

Uninstalling Samsung Software

Uninstall is required if you are upgrading the software or if your installation fails. You can uninstall all software including SmarThru and MFP drivers using the SmarThru CD or selectively uninstall the desired item using the Windows unInstallShield.



NOTE: Before beginning uninstallation, ensure all applications are closed on your PC. A system reboot is required after the software is uninstalled.

Uninstalling the MFP Driver

- 1 Start Windows if not already started.
- 2 From the **Start** menu, select **Programs**, then select **Samsung SF-430 Series**.

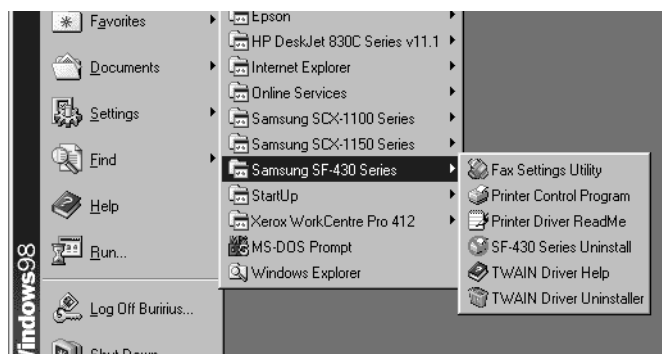

▲ In case of Windows 98

- 3 You can select the component in the MFP driver to uninstall individually.

To uninstall the scan driver, select **TWAIN Driver Uninstaller**.

To uninstall the printer driver, select **SF-430 Series Uninstall**. Restarting your computer will be required.

- 4 When your computer confirms your selection, click **Yes**. The selected printer driver and all its components are removed from your computer.



- 5 When uninstallation is finished, click **OK**.
- 6 The message box recommends you restart your computer. Click **OK**, and restart Windows.



NOTE: If you want to install the printer driver or the scan driver using the SmarThru CD-ROM, make sure that you select the Setup Type to **Compact**. Or select **Custom** then select **MFP Driver**. For details, see page 1.22.

Uninstalling Samsung SmarThru

- 1 Start Windows if not already started.
- 2 From the **Start** menu, select **Programs**.
- 3 Select **Samsung SmarThru**, then select **SmarThru 3 Uninstall**.

- 4 When your computer asks you to confirm your selection, click **Yes**. The Uninstall Options dialogue box appears.

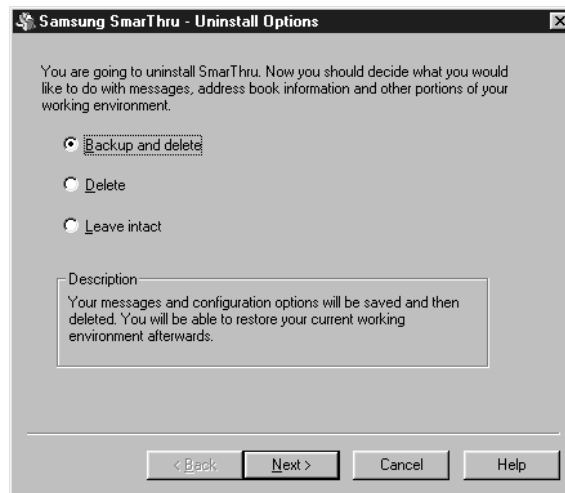

Uninstall options are:

- **Backup and delete:** Backs up all your data and options to a safe place. Then removes the SmarThru system including the data.
- **Delete:** Deletes all the SmarThru data and options. No backup or copying takes place. Be careful while using this option as you can easily lose your data.
- **Leave intact:** Uninstalls SmarThru software leaving data and options intact. This can be useful, if, for example, you decide to install Stand Alone configuration over SmarThru Networking. In this case, uninstall Samsung SmarThru having **Leave intact** option set and install SmarThru Stand Alone configuration.

- 5 After selecting the uninstall option, click **Next**.

- 6 Follow the on-screen instructions to complete the un-installation. The SmarThru software and all components will be removed.



- 7 When uninstalling is finished, click **OK**. The message box recommends restarting your computer.
- 8 Click **OK**.
- 9 Shut down and restart your computer to complete the uninstallation process and save your changes.

Using the SmarThru CD-ROM

You can uninstall both the MFP driver and the SmarThru software with the CD-ROM you used to install the software.

- 1 Insert the SmarThru CD-ROM into your CD-ROM drive.

The SmarThru CD-ROM should automatically run and the opening window appear. (If the opening window does not appear, select **Run** from the Start menu, then type **X:Autorun**, replacing "X" with the letter of your drive and click **OK**.

- 2 Click **Uninstall the Samsung software on your PC**.

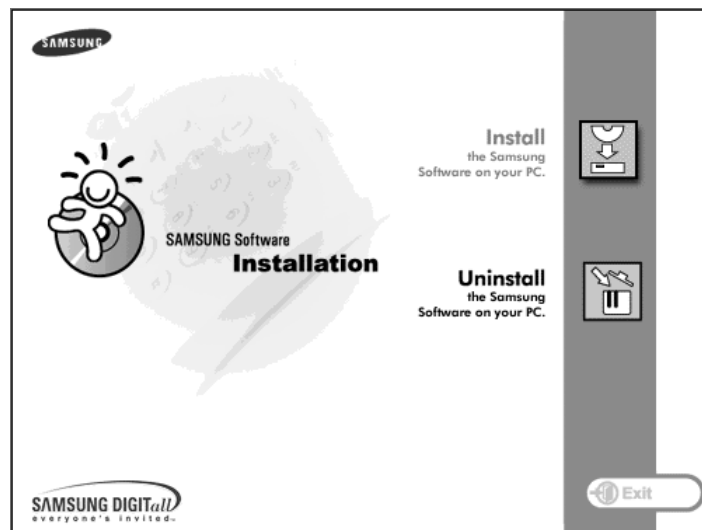

- 3 Follow the on-screen instructions to complete uninstallation.

You must shut down and restart your computer before any changes you have made will come into affect.

Basic System Setup

Setting Date and Time

If you are setting up the product for the first time, or if the product has not been operated for an extended period of time in power plug off, the LCD display prompts you to set the current date and time.

The current date and time are shown on the display when the product is in Standby mode. The time and date are also printed on all faxes you send.

In Standby mode, you can also access the date and time setup menu at any time by taking the following steps:

- 1 Press **Setup**. The display shows "1.SYSTEM SETUP" on the bottom line.
- 2 Press **Enter**. The display shows "FAX NUMBER/NAME" on the bottom line.
- 3 Press the **Scroll** buttons (◀ or ▶) until you see "DATE/TIME", and then press **Enter**. The date currently set for the product is displayed.

Take the following steps to enter your current date and time:

- 1 A flashing cursor prompts you to enter the date. Use the number keypad to enter the correct date. You can use the **Scroll** buttons (◀ or ▶) to manually move the cursor to a digit you wish to change.



Use the Europe format D-M-Y (Day-Month-Year). You can change the date format to the USA mode M-D-Y (Month-Day-Year). See page 1.36.

- 2** Press **Enter** when the date on the display is correct.

If you enter an invalid number, the product beeps and does not proceed to the next step. If this happens, just re-enter the correct number.

- 3** The display asks you to enter the time. Use the number keypad to enter the current time using 24-hour format.



You can change the clock mode to 12-hour format (e.g. 13:00 as 01:00 PM). See page 1.36. Use the **Scroll** buttons (◀ or ▶) to select AM or PM in 12-hour mode.

- 4** Press **Enter** when the time on the display is correct.

The display automatically returns to Standby mode.

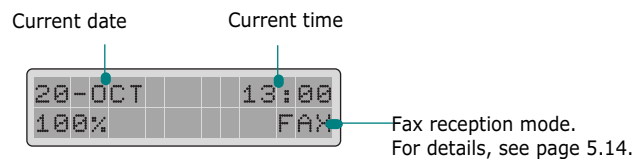

Changing Date Format

Your product displays the current date in Europe format. Europe format displays the date in a format of Day-Month-Year. You can change the date format to USA format (Month-Day-Year).

Take the following steps to change the date format:

- 1 Press **Setup**. The display shows "1.SYSTEM SETUP" on the bottom line.
- 2 Press **Enter**.
- 3 Press the **Scroll** buttons (◀ or ▶) until you see "DATE FORMAT" and then press **Enter**. The date format currently set for the product is displayed.

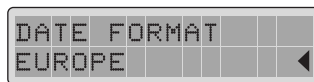

- 4 Press ◀ or ▶ to select the other format and then press **Enter** to save the selection.

Changing Clock Mode

You can configure the product to display time using either a 12 hour or 24 hour format.

Take the following steps to change the date format:

- 1 Press **Setup**. The display shows "1.SYSTEM SETUP" on the bottom line.
- 2 Press **Enter**.
- 3 Press the **Scroll** buttons (◀ or ▶) until you see "CLOCK MODE" and then press **Enter**. The clock mode currently set for the product is displayed.
- 4 Press the **Scroll** buttons (◀ or ▶) to select the other mode and then press **Enter** to save the selection.

Setting Fax Number and Name

In some countries you are required by law to indicate your fax number on any fax you send. Your telephone number and name (or company name), will be printed at the top of each page sent from your product.



NOTE: Depending on your country, the Fax Number and Name setting may be unavailable.

- 1 Press **Setup**. The display shows "1.SYSTEM SETUP" on the bottom line.
- 2 Press **Enter**. The display shows "FAX NUMBER/NAME" on the bottom line.
- 3 Press **Enter**. If there is a number already set, the number appears on the bottom line.



- 4 Enter your fax telephone number. You can include the + symbol in the phone number by pressing the * button and the - symbol by pressing the # button.

If you make a mistake, move the cursor under the wrong character by pressing the **Scroll** buttons (◀ or ▶) and press the correct number. To delete a number, press **Search/Delete**.

- 5 Press **Enter** when the number on the display is correct. The display asks you to enter the name.



- 6 Enter your name or company name by using the number keypad.

For details on how to use the number keypad to enter alphanumeric characters, see page 1.38.

If you want to enter the same letter or number in succession (e.g. SS, AA, 777), enter one digit, then move the cursor by pressing the ► button, and enter the next digit.

If you want to insert a space in the name, you can also use the ► button to move the cursor to skip the position.

- 7 Press **Enter** when the name on the display is correct.

The display automatically returns to Standby mode.

Entering Characters Using the Number Keypad

As you perform various tasks, you'll need to enter names and numbers. For example, when you set up your product, you enter your name (or your company's name) and telephone number. When you store one-touch dial, Speed dial or Group dial numbers, you may also enter a corresponding name.

To enter alphanumeric characters:

- 1 When prompted to enter a letter, locate the button labelled with the character you want.

Press the button repeatedly until the correct letter appears in the display.

For example, to enter the letter **O**, press **6**, (labelled MNO).

Each time you press **6**, the display shows a different letter, first **M**, then **N** and **O**, and finally **6**.

You can enter special characters (space, plus sign, etc.). For details, see "Keypad Character Assignment" on page 1.39.



- 2 To enter additional letters, repeat step 1.

If the next letter is printed on the same button, move the cursor by pressing the ► button, then press the button labelled with the letter you want.

The cursor moves right and the next letter appears in the display.

- 3** When you finish entering letters, press **Enter**.

Keypad Character Assignment

Key	Assigned numbers, letters or characters
1	Space 1
2	A B C 2
3	D E F 3
4	G H I 4
5	J K L 5
6	M N O 6
7	P Q R S 7
8	T U V 8
9	W X Y Z 9
0	+ - , . ' / * # & 0

Editing Numbers or Names

If you make a mistake, move the cursor under the wrong character by pressing the **Scroll** buttons (◀ or ▶) and enter the correct number. To delete a letter, press **Search/Delete**.

Inserting a Pause while Entering a Number

With some telephone systems, you must dial an access code (9 for example) and listen for a second dial tone. In such cases, you must insert a pause in the telephone number. You can insert a pause while you are setting up automatic dial numbers.

To insert a pause, press **Redial/Pause** at the appropriate place while entering the telephone number. "P" will appear in the display at the corresponding location.

Changing the Display Language

- 1 Press **Setup**. The display shows "1.SYSTEM SETUP" on the bottom line.
- 2 Press **Enter**.
- 3 Press ◀ or ▶ repeatedly until you see "LANGUAGE", and press **Enter**.
- 4 Press the **Scroll** buttons (◀ or ▶) repeatedly to select the desired language.

The following options can be selectable: English, German, French, Italian, Spanish, Portuguese, or Dutch.

- 5 Press **Enter** to save the selection and return to Standby mode.

Setting the Discard Size

When receiving or copying a document as long as or longer than the paper loaded in the paper bin, you can set the product to discard any excess images at the bottom of the page, to fit on to the paper size in use.



NOTE: If the Auto Reduction feature (page 5.40) is turned ON, discarding parts of the received faxes does not take place.

- 1 Press **Setup**. The display shows "1.SYSTEM SETUP" on the bottom line.
- 2 Press **Enter**.
- 3 Press the **Scroll** buttons (◀ or ▶) repeatedly until you see "DISCARD SIZE", and press **Enter**.

- 4 Enter the desired discard size using the number keypad.

Anything within the margin set will be discarded from received or copied pages.

If the data is outside the margin set, it will be printed on two sheets of paper at the actual size.

- 5 Press **Enter** to save the selection and return to Standby mode.

Setting Sounds

You can set the following sounds:

- Ringer volume: You can adjust the ringer volume. Choose from HIGH, MED, LOW, or OFF. The OFF setting turns the ringer off.
- Alarm sound : You can turn the alarm sound on or off. If set to ON, an alarm sounds when an error occurs.
- Key sound : You can turn the key tone on or off. If set to ON, key tone are heard when a key is pressed.
- Speaker volume: You can adjust the volume of the speaker to desired level.

Ringer Volume, Alarm Sound, Key Sound

- 1 Press **Setup** on the front panel. The display shows "1.SYSTEM SETUP" on the bottom line.
- 2 Press **Enter**.
- 3 Press the **Scroll** buttons (◀ or ▶) repeatedly until you see the desired sound you want to set and then press **Enter**.
- 4 Press the **Scroll** buttons (◀ or ▶) until you see and hear the desired volume setting on the display and then press **Enter** to save the selection.

Adjusting Speaker Volume

- 1** Press **OHD/V.Req**. You'll hear a dial tone if the telephone line is correctly connected to the Line jack.
- 2** Press the **Scroll** buttons (◀ or ▶) repeatedly until you hear the desired loudness. The display shows the current volume level.
- 3** Press **OHD/V.Req** to save the setting and return to Standby mode.

Setting Dialling Mode

You can set the type of telephone system your product is connected to. This setting may be unavailable depending on your country.

- 1** Press **Setup**. The display shows "1.SYSTEM SETUP" on the bottom line.
- 2** Press **Enter**.
- 3** Press the **Scroll** buttons (◀ or ▶) repeatedly until you see "DIALLING MODE", and press **Enter**.
- 4** Press the **Scroll** buttons (◀ or ▶) repeatedly to select the desired mode.

Select "TONE" if the product is connected to a tone dial line.
Select "PULSE" if the product is connected to a pulse dial line.
- 5** Press **Enter** to save the selection and return to Standby mode.

Setting the PIN Code

You can set the product to require a special PIN (Personal Identification Number) code when somebody tries to make colour copy. The PIN code helps you prevent your product being used by unauthorised persons.

Take the following steps to activate this feature and set the PIN code:

- 1** Press **Setup** on the front panel. The display shows "1.SYSTEM SETUP" on the bottom line.
- 2** Press **Enter**.
- 3** Press the **Scroll** buttons (◀ or ▶) repeatedly until you find "PIN CODE", and press **Enter**.
- 4** Press the **Scroll** buttons (◀ or ▶) repeatedly to select "ON", and press **Enter**.

If you want to disable the PIN code, select "OFF". You do not need to continue the following steps.

- 5** The display prompts you to enter the PIN code number. Enter the four-digit code number as your preference using the number keypad.

The PIN code is preset to "0000" at the factory.

- 6** Press **Enter** to save the setting.

You will be required to enter the four-digit code each time you press the **Start Copy Color** button.

Setting the Handset Mode

You can activate the PIN code to restrict the use of the handset by setting the handset mode to ON. This will block the outgoing calls from your product by unauthorised persons.



NOTE: Before enabling this feature, you must enable the PIN code by restricting colour copy. See page 1.43.

- 1** Press **Setup** on the front panel. The display shows "1.SYSTEM SETUP" on the bottom line.
- 2** Press **Enter**.
- 3** Press the **Scroll** buttons (◀ or ▶) repeatedly until you see "HANDSET MODE", and press **Enter**.
- 4** Press the **Scroll** buttons (◀ or ▶) repeatedly to select the desired setting.

If you want to restrict calls from your product, select "ON". Otherwise, select "OFF".

- 5** Press **Enter** to save the selection.

You will be required to enter the four-digit code each time you lift the handset.

Setting Paper and Ink Save Modes

Ink Save

The Ink Save feature allows the printer to use less ink on each page. Activating this mode will extend the life of the ink cartridge, but will reduce the print quality.

To use Ink Save mode, press **SAVE Ink** on the front panel. If the button backlight is on, the Ink Save mode is active and the printer uses less ink when printing from PC, receiving faxes and printing copy pages.

If the button backlight is off, the Ink Save mode is disabled and you will print in a normal quality.

Paper Save

This feature allows you to print 2 pages on a single sheet of paper saving paper. This mode is available only in black and white copy or fax modes.

- 1 Press **SAVE Paper** on the front panel.
- 2 Press the **Scroll** buttons (◀ or ▶) repeatedly until you find the desired setting.

Select "ON" to activate the Paper Save mode.
Select "OFF" to deactivate the Paper Save mode.
- 3 Press **Enter** to save the selection and return to Standby mode.



NOTE: The Paper Save feature may not work when copying or receiving long documents (for example, legal size) because Auto Reduction cannot be achieved.

Memo



1.46

SETUP

2

PRINT

Read this chapter to learn how to select and load print media and how to use the print settings.

The topics included in this chapter are:

- **Paper Selection**
- **Loading Speciality Paper**
- **Printing a Document**
- **Printer Settings**
- **Using the Printer Control Program**

Paper Selection

One of the most important things you can do to assure the best possible printing performance of your product is to select the correct paper. Your product produces letter quality print on most plain bond paper, including cotton bond and photocopying paper; it does not require special ink jet paper. However, the print quality varies with different paper types. Be sure to test a type of paper before you purchase a large quantity.

Your printer supports the following types of paper. Select the right paper.

- **Plain Paper**
The product supports paper sizes of letter, legal, and A4 in portrait orientation. You can use regular copier paper, cotton bond papers, and typical letterhead. Always use paper without curls, folds, staples, or damaged edges.
- **Coated paper**
Paper developed for high quality printing with minimal or no smearing or running when in contact with water or damp surfaces.
- **Glossy/Photo Paper**
A high gloss, thicker paper that produces the look and feel of a photograph. Use this paper to produce photo-realistic prints from your printer.
- **Transparency**
Your transparencies should be products designed for use in Ink Jet products, with excellent contrast, sharpness, and colour quality. The transparency is placed in the product with the image side up.
- **Iron-on Transfer**
Use inkjet T-shirt transfers to create and personalize T-shirts, sweatshirts, aprons, tablecloths, napkins, tote bags, and anything else your imagination allows! Use on any cotton or cotton/poly blend fabric. Your image is printed in mirror image so when you iron it onto the T-shirt, the image is viewed correctly.
- **Greeting Card Stock**
You can create greeting cards, business cards, invitations, announcements, and more.



NOTE: When you print on different papers, you have to set the appropriate paper type in your application. See page 2.10.

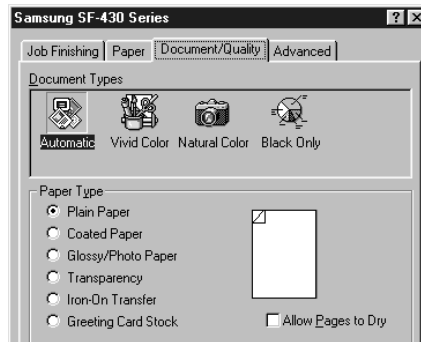

2

Guidelines for Special Media

Be sure to read any instructions that come with your special paper. These instructions provide important information regarding how to achieve the highest print quality with these papers.

- It is recommended that you feed special paper types one sheet at a time.
- For transparencies and glossy photo paper, follow these guidelines:
 - Let the printed sheets dry completely before handling or storing them.
 - When a printed sheet has dried completely, cover the printed side with a sheet of plain (not coated) paper before storing it, this is recommended even if you place the sheets in a clear file or plastic holder.
 - Do not leave the film in the paper output tray for long periods of time. Dust and dirt may accumulate on the film resulting in spotty printing.
 - To avoid smudging caused by fingerprints, handle transparency film and coated paper carefully.
 - To avoid fading, do not expose the printed film to prolonged sunlight.

PRINT

2.3

- Store unused media flat. Do not remove paper from its protective packaging until you are ready to use it.
- Store unused media at temperatures between 59 and 86 °F (15 to 30 °C). The relative humidity should be between 10% and 70%.
- If the print density of your page is very high, light paper stock may curl slightly due to the large amount of ink. If you need to print dense graphics, try printing on heavier stock.
- Do not use thicker paper than meets the specifications for this product. Printing with a paper that is thick enough to come in contact with the print head nozzles may damage the cartridge.

Loading Speciality Paper

Follow these guidelines when loading speciality paper:

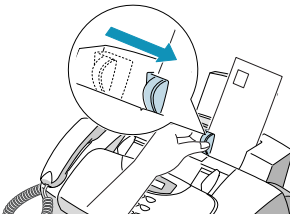
Load up to:	And make sure:
100 sheets of 20lb plain paper	<ul style="list-style-type: none"> •The print side is facing you. •The paper is against the right side of the paper support. •The paper guides rest against the edge of the paper.
10 envelopes	<ul style="list-style-type: none"> •The print side is facing you. •The envelopes are loaded vertically against the right side of the paper support. •The stamp location is in the upper left corner. •The paper guides rest against the edge of the envelopes. 
10 greeting cards, index cards, postcards, or photo cards	<ul style="list-style-type: none"> •The print side is facing you. •The cards are loaded vertically against the right side of the paper support. •The paper guides rest against the edge of the cards.

Load up to:	And make sure:
25 sheets of photo paper	<ul style="list-style-type: none"> •The glossy or coated side is facing you. •The paper guides rest against the edge of the photo paper.
10 transparencies	<ul style="list-style-type: none"> •The rough sides of the transparencies are facing you. •The paper guides rest against the edge of the transparencies.
100 sheets of custom size paper	<ul style="list-style-type: none"> •The print side is facing you. •Your paper size fits within these dimensions: <ul style="list-style-type: none"> - Width: 76 mm to 216 mm (3.0 in. to 8.5 in.) - Length: 127 mm to 432 mm (5.0 in. to 17.0 in.) •The paper guides rest against the edge of the paper
25 iron-on transfers	<ul style="list-style-type: none"> •You follow the loading instructions on the iron-on packaging. •The print side (blank side) is facing you. •The paper guides rest against the edge of the iron-on transfers.

Paper Guidelines

- When loading paper, envelopes, or other special media, keep these guidelines in mind:
- Attempting to print on damp, curled, wrinkled, or torn paper can cause paper jams and poor print quality.
- Use only high quality inkjet or copier grade paper. Avoid paper with embossed lettering, perforations, or texture that is too smooth or too rough.
- Store paper in its ream wrapper until ready to use. Place cartons on pallets or shelves, not on the floor. Do not place heavy objects on top of the paper, whether it is packaged or unpackaged. Keep it away from moisture, or other conditions that can cause it to wrinkle or curl.
- During storage, moisture-proof wrap (any plastic container or bag) should be used to prevent dust and moisture from contaminating your paper.
- Always use paper and other media that conform with those listed under "Paper Specification" on page 8.5.

- Use only well-constructed envelopes with sharp, well creased folds.
- DO NOT use envelopes with clasps and/or snaps.
- DO NOT use envelopes with windows, coated linings, self-adhesive seals, or other synthetic materials.
- DO NOT use damaged or poorly made envelopes.

Printing a Document

This procedure describes the general steps required for printing from various Windows applications. The exact steps for printing a document may vary depending on the application program you are using. Refer to your software application's documentation for the exact printing procedure.

The following steps describe the typical process to print from a Windows environment:

- 1** Ensure that your Samsung SF-430 is properly connected to the computer, the product is powered on, and there is paper in the paper bin.
- 2** Verify that you have installed the Samsung software for your computer. For details, see "Installing Samsung Software" on page 1.21.
- 3** Start the program you are using to create the document, and create or open the document you want to print.

- 4 Choose **Print** or **Print Setup** from the **File** menu. Make sure that **Samsung SF-430 Series** is selected as your default printer. Click **Properties** or **Setup** if you want to make any adjustments that are appropriate for printing your document. (For details, see "Printer Settings" on page 2.8.)

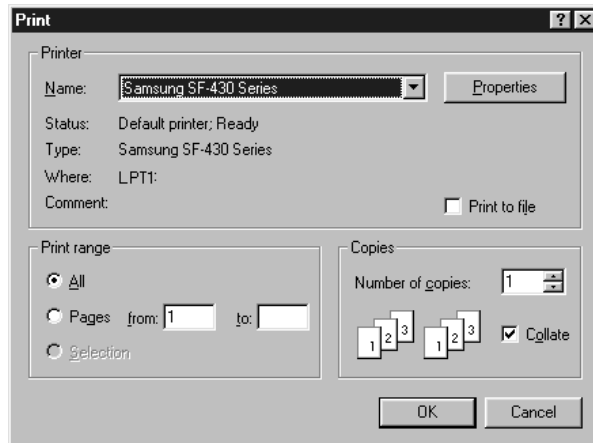

▲ In case of Windows 98

- 5 Click **OK** to close the Properties dialogue box.
- 6 After making any necessary changes to the printing parameters, click **OK** to start the print job.

After a moment, the Samsung SF-430 Series Control Program window appears. You can cancel the print job as well as seeing how much ink you have left and view printing tips in this window.



▲ In case of Windows 98

For Windows 2000/XP, the Control Program does not appear. Right-click on the printer icon on the taskbar at the bottom right corner of the desktop window. From the pop-up menu, you can select commands to cancel, pause, or resume printing.



NOTE: If you want to use another printer instead of SF-430, you must disable the scan monitor on the taskbar at the bottom right corner of the desktop window. The scan monitor is enabled as long as SF-430 is connected to your computer and turned on. To disable the scan monitor, right-click on the scan monitor and select **Disable** from the pop-up menu.

Printer Settings

You can use the product with all your Windows 95/98/Me/2000/XP or Windows NT 4.0 applications. Be sure to set Samsung SF-430 Series as the default printer for all your Windows operations.

Most Windows software applications allow you to make changes to the printer settings. This includes settings that determine how a print job looks such as paper size, paper orientation, and margins. Settings made in the application to create the document will usually override settings made in the printer driver.



NOTE: You do not need to use any of the front panel buttons to use the product as a PC printer. For example, if you want to adjust the printing contrast you do not have to press **Contrast** on the front panel. The front panel buttons are used primarily for copying.

Accessing Printer Settings

You can access printer settings by using either of these methods.

Windows 95/98/Me

- Select the **File > Print > Properties** or **File > Print Setup** command from within any Windows application.

Or

- Select **Samsung SF-430 Series** printer from the **Printers** folder, then select **File > Properties** (or select the printer icon in the **Printers** folder, and click the right mouse button).

2

Windows NT 4.0

- Select the **File > Print > Properties** or **File > Print Setup** command from within any Windows application.

Or

- Select **Samsung SF-430 Series** printer from the **Printers** folder, click the right mouse button, then select **Document Defaults** from the drop-down list.

Windows 2000/XP

- Select the **File > Print > Properties** or **File > Print Setup** command from within any Windows application.

Or

- Select **Samsung SF-430 Series** printer from the **Printers** folder, click the right mouse button, then select **Printing Preferences** from the drop-down list.

Printer Properties Tabs (Windows 95/98/Me)

When the Printer Properties are displayed, you can review and change whatever settings are needed for your print job.

Your printer's Properties window consists of 4 tabs: **Paper**, **Quality**, **Job Finishing** and **Advanced**.

If you access the Printer Properties through the **Printers** folder, you can view more Windows-based tabs, as well as these 4 tabs. For information on the Windows-based tabs, refer to your Windows User Guide.



NOTE: If you access the Printer Properties through the **Printers** folder, any settings made will become the default settings for the printer. Settings made when the Printer Properties are accessed through an application **File** menu and **Print** or **Print Setup** will remain active until the application you are printing from is closed.

Paper Tab

Use the **Paper** tab to select what size of paper you have in your printer, the orientation, the number of copies to print, etc.

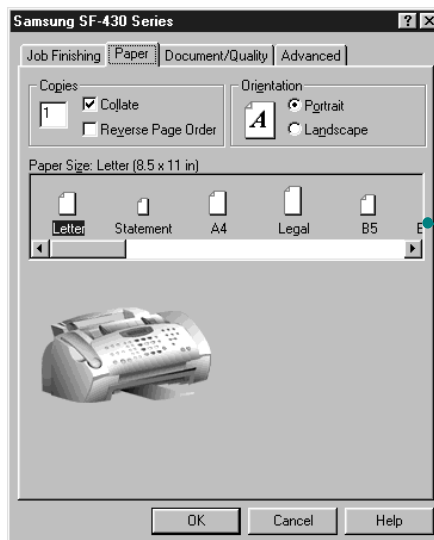

Select the paper size you have loaded in your printer. If you have a special size of paper to print on, select **Custom** and define its size in the custom paper size. The minimum you can use is 3 by 5 inches and the maximum is 8.5 by 17 inches.

Document/Quality Tab

The **Document/Quality** tab controls the document and paper type, such as plain, coated, and glossy. It also controls the quality (resolution) of the printing. Higher resolutions print better, but take longer and consume more ink. Selecting **Web Smoothing** allows you to print clearer images from the Internet.

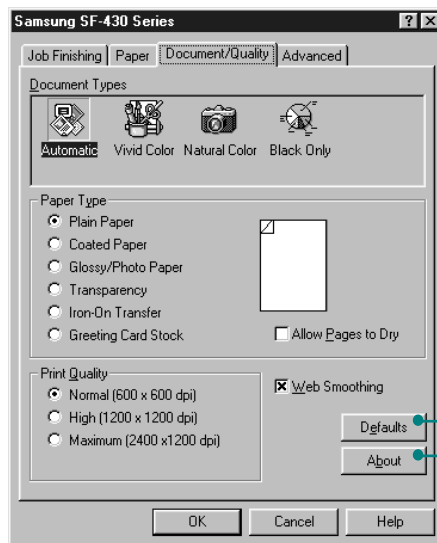

Resets to the default settings.

Shows the printer driver version.

Job Finishing Tab

The **Job Finishing** tab provides options for you to adjust how the document will appear on the printed page. **Job Finishing** options can include **Poster**, **Handout**, **Booklet** and **Two-sided printing**.

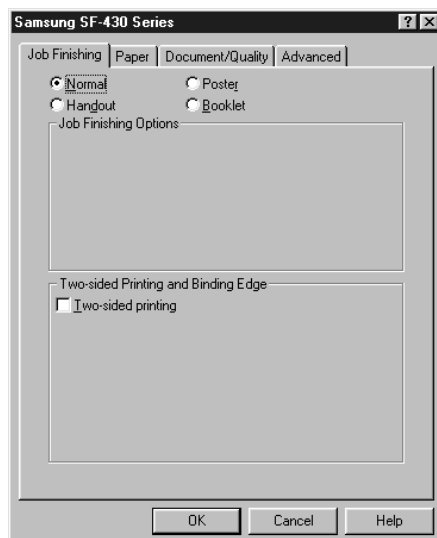

Booklet

The Booklet option allows you to print a document out as a booklet. If the **Print reloading instructions after the first side prints** is checked, a page will print directing you how to insert the paper so that the booklet prints correctly.

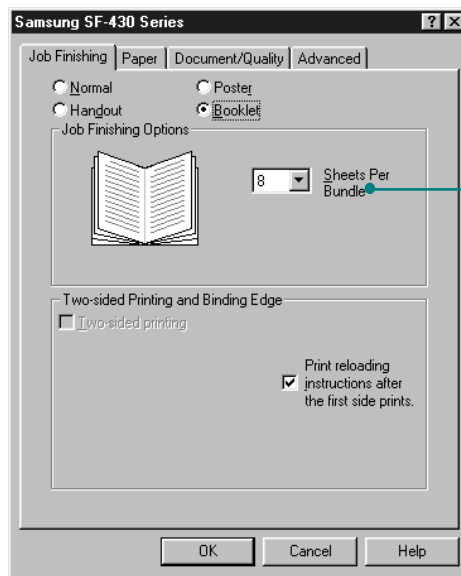

A bundle is any number of sheets of paper folded together. When printing with a heavier paper stock, select a smaller number of Sheets Per Bundle.

Once your document prints, stack the bundles and bind the booklet.

- 1** Take the first bundle from the paper output tray, fold it in half, and set it aside.
- 2** Fold and stack the rest of your bundles, one on top of the other, until your booklet is complete.
- 3** Bind the bundles.



Poster

Choose the **Poster** option to enlarge the printed document. If you check **Show Crop Marks**, the image will print with crop marks. The white space around the image can easily be trimmed.

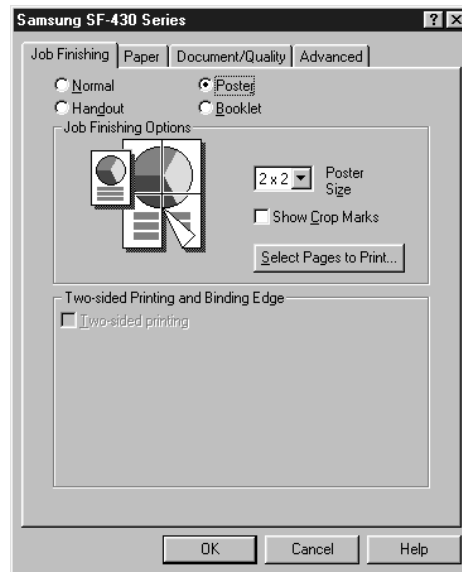

Handout

Choose the **Handout** option to print multiple pages on a single sheet of paper.

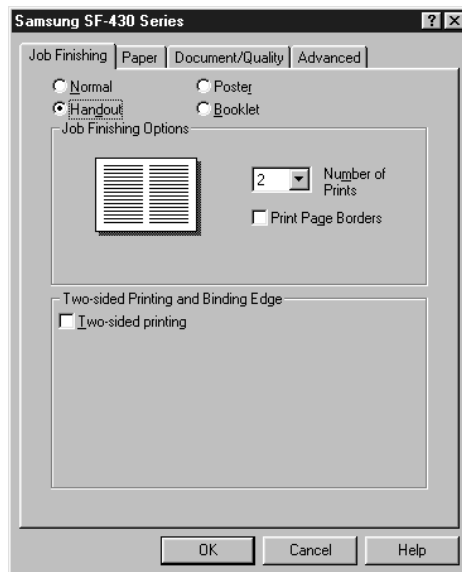

Two-Sided Printing

Choose the **Two-sided printing** option from the **Job Finishing** tab to print the document on both sides of the paper. You can choose the binding type from **Long Edge Binding** or **Short Edge Binding**.

Advanced Tab

The **Advanced** tab allows you to change how the printer handles colour printing. You should rarely need to change these settings.

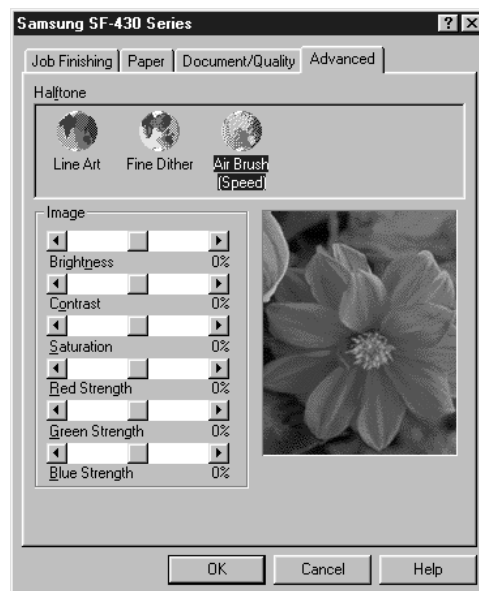

Printer Properties Tabs (Windows NT 4.0)

Page Setup Tab

This tab allows you to set page properties including number of copies, collate, print quality, orientation, reverse order printing, paper size, and paper type.

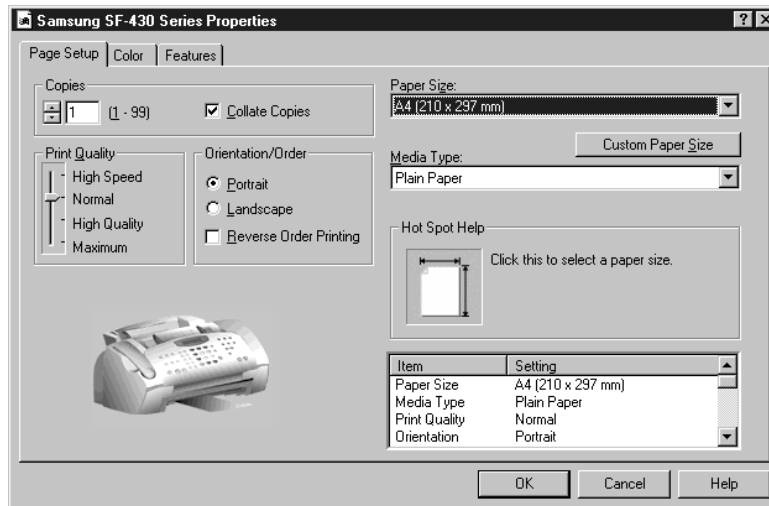

Color Tab

Use the **Color** tab for optimising the graphic and colour print job. You can adjust halftone shading, brightness and contrast. You can also select the colour appearance and the document colour.

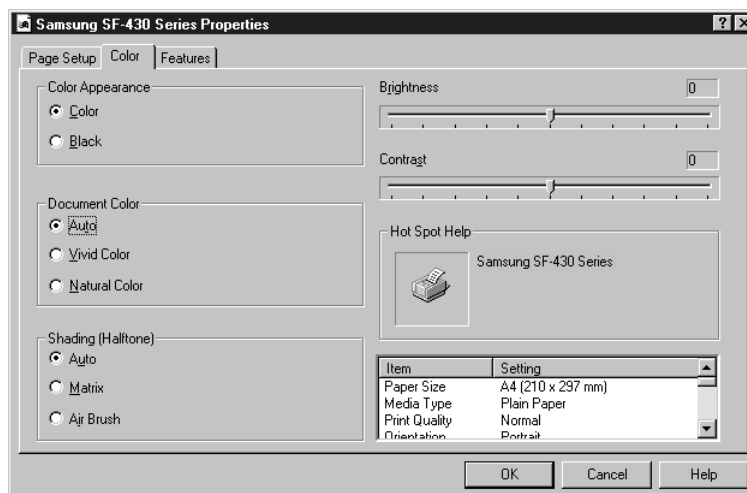

Feature Tab

You can select the Dry Time Delay option and the two-sided printing option. You can also access Cartridge Maintenance features from this tab.

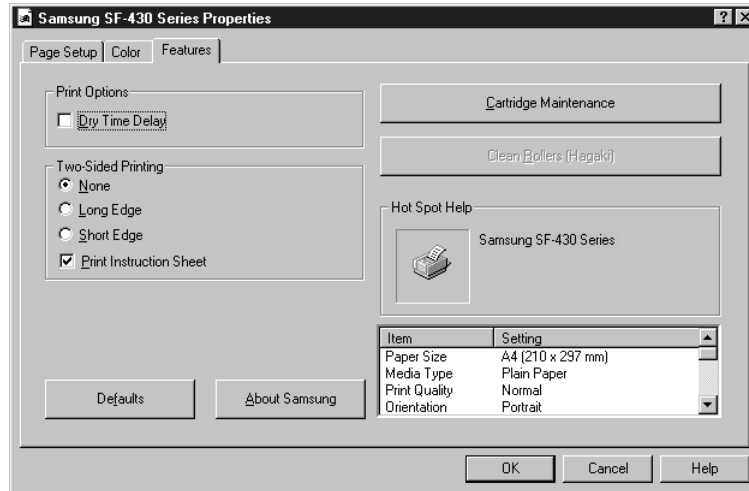

NOTE: In Windows NT 4.0, Poster, Handout, and Booklet printing are not provided.

Printer Properties Tabs (Windows 2000/XP)

Paper Quality Tab

This tab allows you to select paper source, paper type, print quality, and colour. The **Advanced** button under this tab allows you to select advanced document settings including paper size, print resolution, and colour intent.

2

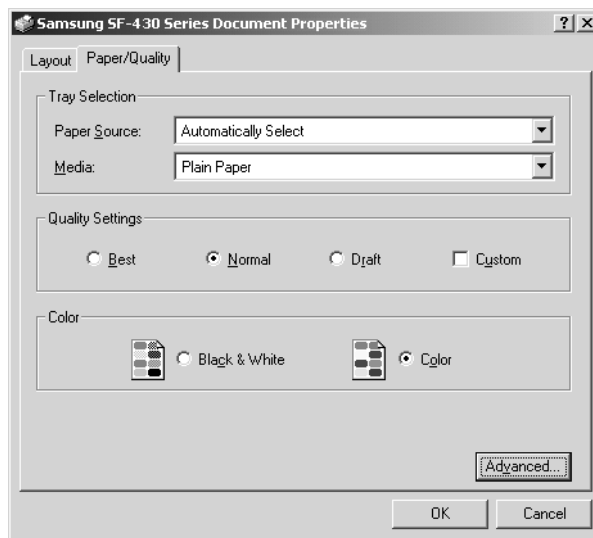

Layout Tab

Use the **Layout** tab to select print orientation, and page order.

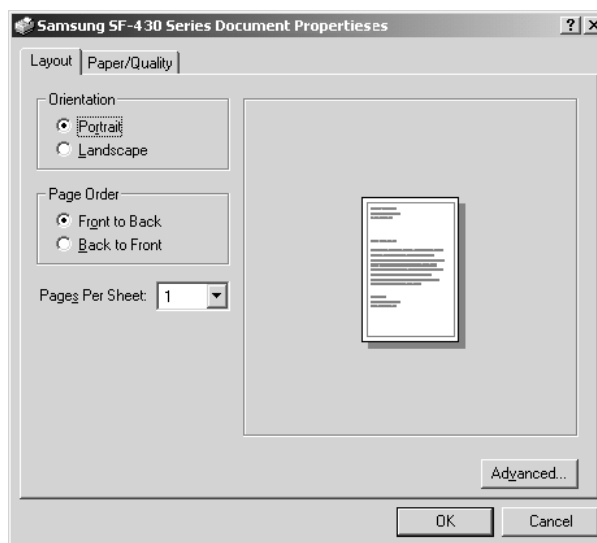

Printer Properties Buttons & Icons

- Click **OK** when done reviewing or making changes.
- Click **Cancel** if you want to exit the tab menus without applying any changes.
- Click **Help** to view the online Help feature and tab menu details.
- Click the **?** icon in the title bar. Position the **?** pointer over the parameter in question and click to see a pop up window explaining that parameter.

Using the Printer Control Program

The SF-430 Series Control Program contains setup options that define the operation of your product.



NOTE: The Printer Control Program is not available in Windows 2000/XP.

Accessing the Printer Control Program

- 1** Click **Start > Programs > SAMSUNG SF-430 Series > Printer Control Program**.



NOTE: Windows NT 4.0 users can also access the Printer Control Program from the Printer Properties window. See page 2.15.

2 The Samsung SF-430 Series Control Program window appears. The appearance of the window may be different from the ones below depending on your Windows operating system. Click the appropriate tab for the options you want to display, and make the necessary changes on each tab.



NOTE: Click **Help** on any tab in the Control Program window to access on-line Help.

Status Tab

The **Status** tab gives you general status information on the printer. You will see this window when the printer is printing (unless you've set the Control Program Options to **Run Minimized**, using the options on page 2.20).

Once a print job has started, you can use this window to cancel the print job or monitor the job progress.

The ink level of the cartridges is also displayed. Use the gauges to help you determine when they need replacing.



NT 4.0 provides this button in the Cartridge tab.

▲ In case of Windows 98

Options Tab

From the **Options** tab, you can control some of the behaviour of the Control Program. The options available will vary depending on your Windows operating system. Some of the options activate under a specific printing environment such as network printing. Click **Help** for further information.

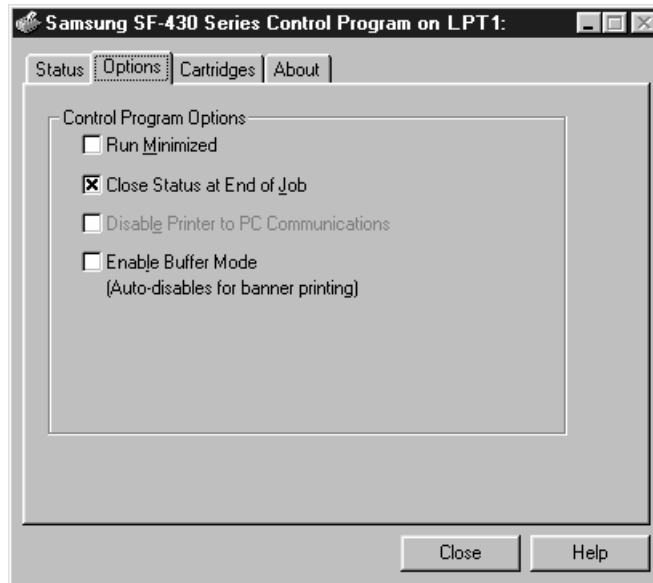

▲ In case of Windows 98.

Cartridges Tab

The **Cartridges** tab gives you access to several different cartridge functions. From here, you can install new cartridges, change them, clean your print nozzles, align your cartridges, or order supplies from the internet.

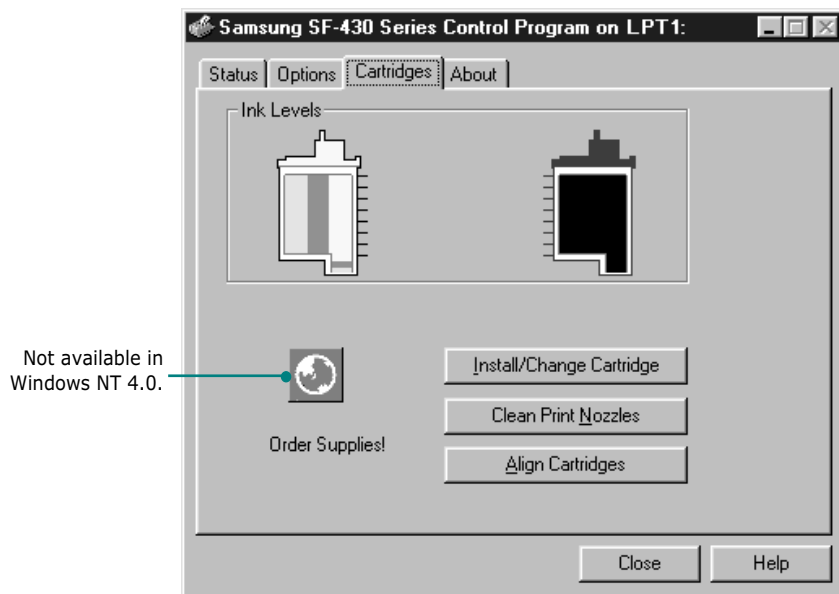

▲ In case of Windows 98



NOTE: If you are using Windows 2000/XP, you can access the Cartridge Maintenance tab through the printer properties by taking the following steps:

1. Click **Start > Settings > Printers**.
2. Right-click on the **Samsung SF-430 Series** printer from the Printers folder.
3. From the pop-up list, select **Properties**.
4. Click the **Cartridge Maintenance** tab.

About Tab

The **About** tab gives you the program version number. If you click on the globe image on the bottom of the window, you will be connected to the Samsung web site provided you are connected to the internet.

Memo



2.22

PRINT

3

COPY

You can use your SF-430 like a standard copier. You don't even have to turn your computer on. The buttons on the operation panel let you make all the basic settings: paper type and size, copy size, copy contrast and quality, number of copies, and colour or black and white.

This chapter includes:

- **Setting Paper Size and Type**
- **Copying a Document**
- **Setting Copy Options**
- **Changing Default Settings**

Setting Paper Size and Type

First make sure you have paper loaded, following the instructions in "Loading Paper" on page 1.11. Then you have to set the paper size and type using the front panel buttons.



NOTE: These settings are applied to the stand-alone copy mode only.

Paper Size

After loading paper, take the following steps to set the paper size from the front panel:

- 1 Press **Setup** on the front panel. The display shows "1.SYSTEM SETUP" on the bottom line.
- 2 Press the **Scroll** buttons (◀ or ▶) until you see "3.COPY SETUP" and then press **Enter**.
- 3 The display shows the first option "PAPER SIZE". Press **Enter** to access the Paper Size option.

The current setting is tagged with a ◀ at the right end of the display.

- 4 Press the **Scroll** buttons (◀ or ▶) to select the paper size you are using in the display.

LETTER, A4, and LEGAL sizes are available.

- 5 Press **Enter** to save the selection and return to Standby mode.



NOTE: When you use legal-size paper, do not pull out the paper output tray. If you do, a paper jam may occur.

Paper Type

You can use special media such as inkjet, transparency, and photo paper as well as plain paper. After loading any special type of media, set the paper type using this menu:

- 1** Press **Setup** on the front panel. The display shows "1.SYSTEM SETUP" on the bottom line.
- 2** Press the **Scroll** buttons (◀ or ▶) until you see "3.COPY SETUP" and then press **Enter**.
- 3** Press the **Scroll** buttons (◀ or ▶) until you see "PAPER TYPE" and press **Enter**.

The current setting is tagged with a ◀ at the end of the display.

- 4** Press the **Scroll** buttons (◀ or ▶) until you see the paper type you are using in the display.
- 5** Press **Enter** to save the selection and return to Standby mode.

3

Copying a Document

Simply pressing the **Start Copy** buttons on the front panel allows you to copy using the default copy quality and quantity settings: one normal page. You can change the default copy settings which will apply when copying documents using the corresponding buttons on the front panel. See "Setting Copy Options" on page 3.5.

Follow these steps to copy using the front panel:

- 1** Feed the document to be copied face down into the Automatic Document Feeder using light forward pressure until "DOCUMENT READY" appears in the LCD display.

If necessary, adjust the document guides to match the width of the document.

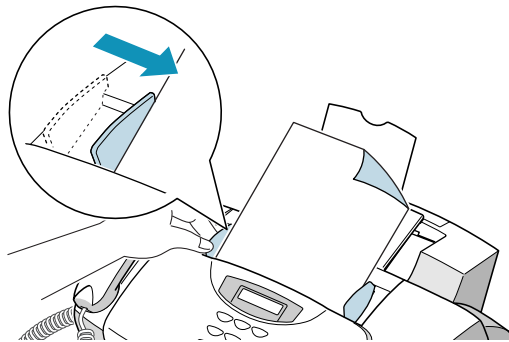

You can insert up to 30 sheets at a time. If you insert more than one sheet, make sure the bottom sheet enters first. Stagger the leading edge of the sheets slightly, and insert the sheets with a slight push to ensure smooth feeding.

To add pages while the document is being copied, insert them into the loading slot on top of the already loaded sheets.

If you're loading pages that are unusually thick or thin, feed one sheet at a time.

- 2** Customise the copy settings including copy quality, contrast, number of copies, and copy size if necessary. See "Setting Copy Options" on page 3.5.

- 3** When you are finished setting the copy options, press **Start Copy Black** to begin a black and white copy or **Start Copy Color** for a colour copy.

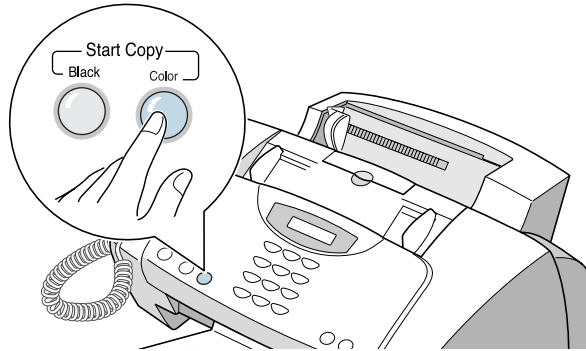

3



NOTES: If you want to cancel the copy job, press **Cancel/Reset** during copying

Setting Copy Options

The following buttons on the front panel let you make all the basic settings: copy quality, contrast, number of copies and copy size. You can cancel the settings and reset to default settings by pressing **Cancel/Reset** at any time while you are setting the options.



NOTES: The option settings for the current copy job will be automatically reset to their default status (page 3.9) 2 minutes after the job is completed. If necessary, you can reset the copy options immediately by pressing **Cancel/Reset**.

Quality

To select the copy quality, use the **Quality** button on the operation panel. You can select **DRAFT**, **NORMAL**, or **BEST**. The BEST mode is good for documents with fine details. The copy quality is good but the copy speed is low. The NORMAL mode works well for normal documents (text). The DRAFT mode can be used for fast copying with lower resolution.

COPY

3.5

To select copy quality:

- 1** Press **Quality**. The current setting is tagged with a ◀ at the end of the display.
- 2** Scroll through the options available by pressing **Quality** repeatedly or using the **Scroll** buttons (◀ or ▶).
- 3** When the desired mode is displayed, press **Enter** to save the selection.



NOTE: While the Paper Save feature is active, you cannot change the quality using the **Quality** button. The quality is fixed to "NORMAL".

Contrast

Contrast is the difference in brightness between the lightest and darkest parts of a printed document. You can adjust the contrast the product will use to copy a document. Adjust it according to how light or dark your document is.

You can select **LIGHTEN**, **PHOTO**, **DARKEN** or **NORMAL**. The **LIGHTEN** contrast is good for documents containing dark images. The **NORMAL** contrast works well with a standard document. The **DARKEN** contrast works well with light print or faint pencil markings. Choose the **PHOTO** contrast if you are copying a photograph.

To select the contrast:

- 1** Press **Contrast**. The current setting is tagged with a ◀ at the end of the display.
- 2** Scroll through the options available by pressing **Contrast** repeatedly or using the **Scroll** buttons (◀ or ▶).
- 3** When the desired mode is displayed, press **Enter** to save the selection.

Copy Page

You can select the number of copies you want from 1 to 99. To change the number of copies:

- 1 Press **Copy Page** on the front panel.
- 2 Enter the desired number of copies using the number keypad.
- 3 When the desired number is displayed, press **Enter** to save the selection.

If you select multiple copies, you can set your product to sort the copy job. For details, see page 3.8.



NOTE: When making a colour copy, you cannot make multiple copies.

3

Zoom Rate

You can reduce or enlarge the size of a copy image from 25% to 400% using the **Zoom Rate** button on the front panel.

To select the zoom rate from pre-defined copy sizes:

- 1 Press **Zoom Rate** until the setting you want appears on the display.
- 2 Press **Enter** to save the selection.

To fine-tune the size of copies:

- 1 Press **Zoom Rate** until you see 'CUSTOM 100% ◀' on the display and then press **Enter**.
- 2 Enter the desired rate using the number keypad
- 3 Press **Enter** to save the selection.



NOTE: When the Paper Save feature is active, the zoom rate you previously selected is ignored.

Collation

If you are making multiple copies, you can set your product to sort the copy job and change the print order.

- 1** Press **Setup**. The display shows the "1.SYSTEM SETUP" on the bottom line.
- 2** Press the **Scroll** buttons (◀ or ▶) until you see "3.COPY SETUP" and then press **Enter**.
- 3** Press the **Scroll** buttons (◀ or ▶) until you see "COLLATE" and then press **Enter**.

The current setting is tagged with ◀ at the end of the display.

- 4** Press the **Scroll** buttons (◀ or ▶) to select ON and press **Enter**.

The product will now collate the copy job. For example, 2 copies of a 3 page job; it will print one complete document followed by the second complete document, (e.g. 1, 2, 3 then 1, 2, 3).

The OFF setting disables the collation and you don't need to continue the following steps. The product will print all the copies of one page and then the next page.

- 5** The display prompts you to select the copy print order. Select the desired print order by using the **Scroll** buttons (◀ or ▶).
 - **NORMAL** : Set to collate in normal order.
 - **REVERSE** : Set to collate in reverse order. The product prints the last page first so that you do not need to rearrange the printed copies.
- 6** Press **Enter** to save the selection and return to Standby mode.



NOTES:

- When you make a colour copy, collation is disabled.
 - If the memory gets full while making black and white copies using collation, collation automatically is disabled.
-

Changing Default Settings

The copy options including copy quality, contrast, number of copies and copy size can be set to the most frequently used modes. When a document is copied, the default settings will be used unless otherwise you do not change for the individual copy job by using the corresponding buttons on the front panel.

To create your own default settings:

- 1** Press **Setup** on the front panel. The display shows "1.SYSTEM SETUP" on the bottom line.
- 2** Press **Enter**.
- 3** Press the **Scroll** buttons (◀ or ▶) repeatedly until you see "SET DEFAULT".
- 4** Press **Enter**. The display shows the first option "CONTRAST".
- 5** Press the **Scroll** buttons (◀ or ▶) repeatedly to scroll through the available setup options.
- 6** When the desired option appears, press **Enter**.
- 7** Change the setting using the **Scroll** buttons (◀ or ▶) and then press **Enter** to save the selection.
- 8** Repeat steps 5 through 7 as necessary.
- 9** To return to Standby mode, press **Cancel/Reset**.

3

Memo



3.10 COPY

4

SCAN

Scanning with the Samsung SF-430 lets you turn pictures and text into digital files on your computer. Then you can fax or e-mail the files, display them on your web site, or use them to create projects that you can print out using Samsung SmarThru software which comes with the product.

This chapter includes:

- **Scanning Basics**
- **Starting Scan from the Front Panel**
- **The Scanning Process with TWAIN-enabled Software**

Scanning Basics

Your SF-430 offers three ways to start scanning. These include:

- From the Samsung SmarThru software: Launch Samsung SmarThru and open the Scan Wizard to start scanning. Please refer to the SmarThru User's Guide.
- From the front panel on your product: Use the **Scan To** button on the front panel to initiate scanning. The SmarThru system launches automatically on your PC and the Scan Wizard window opens on the desktop window.
- From TWAIN-compliant software: You can use other software including Adobe PhotoDeluxe and Adobe Photoshop.



NOTES:

- To scan with your product, you must install the MFP driver.
 - Scanning is done through the same LPT or USB port that is currently assigned for your printer port.
-

Starting Scan from the Front Panel

You can quickly start scanning from the front panel on your product. The Samsung SmarThru program automatically launches and allows you to select the desired scan service. Take the following steps:

- 1 Make sure that your computer and SF-430 are turned on. You will see the scan monitor icon on the taskbar at the bottom right corner of the desktop window unless you disable or have turned it off.



Scan monitor

- 2 Load the document face down into the Automatic Document Feeder.
- 3 Adjust the document guides to match the width of the document.

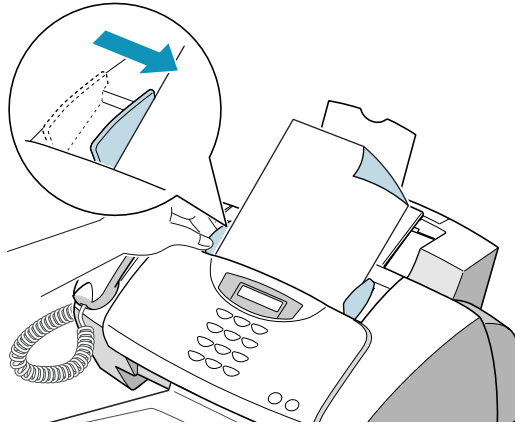

- 4 Slide the sheet down into the document tray until it's gripped by the product.
- 5 Press **Scan To** on the front panel.

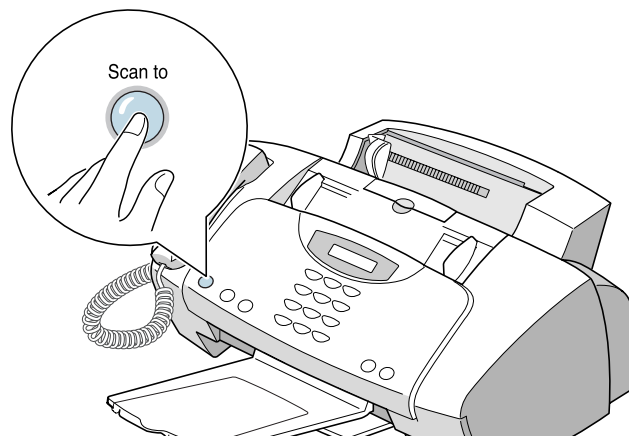

NOTE: If you press **Scan to** when the scan monitor on the desktop window is disabled or turned off (see page 4.2), 'PC NOT AVAILABLE' appears on the SF-430 display and scanning is not possible.

- 6 The Samsung SmarThru starts automatically and the Scan Wizard window opens.



The Scan Wizard lets you use the following services:

- **Scan**

Lets you scan the documents and save them in the Image Manager. The Image Manager is an image database manager and image-editing program.

- **Copy**

Lets you use your product to produce professional quality copies. You can adjust the image size and make advanced settings.

- **Scan to Email**

Lets you scan the documents, then launches a New Message form to send the just scanned image attached to a new mail. The email account must be configured in the Samsung SmarThru system to enable e-mail services.

- **Scan to FAX**

Lets you scan the documents then launches a New Fax form which helps you send them as a fax image.

- **Scan to WEB**

Lets you scan the documents for further publishing to the Web.

- **Scan to OCR**

Lets you scan the documents and pass them to the OCR program. OCR (Optical Character Recognition) is the process of converting a scanned image into text that you can edit in a word processing program. After you scan your document, the software processes or "recognises" it. Then you can edit it and either save the file or open it in a word processing program on your computer.

- 7 Click the desired service.
- 8 The Samsung Scan Manager for the selected service opens. Adjust the scan settings. You can use the **Help** button to get on-line help.

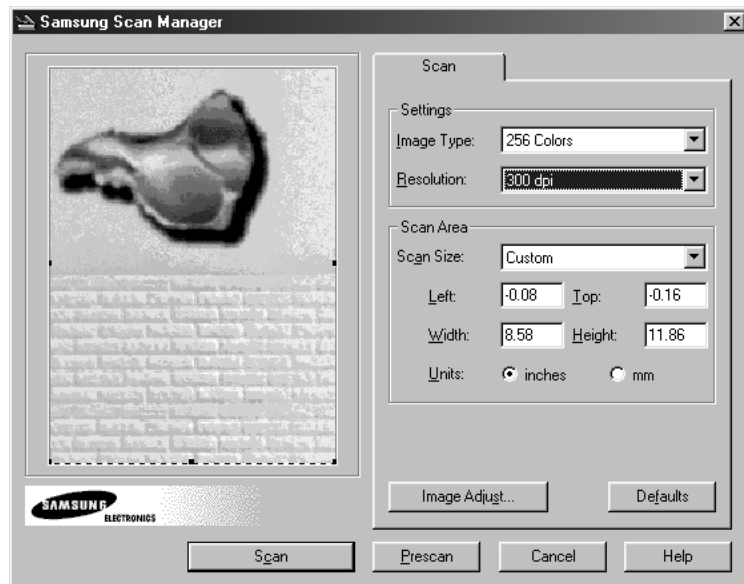

4

- 9 To start scanning, click **Scan**.

For further information, please refer to the SmarThru User's Guide which came with your product.



NOTE: If you want to cancel the scan job, press **Cancel/Reset** at any time.

The Scanning Process with TWAIN-enabled Software

If you want to scan documents using alternative software, you will have to use a TWAIN-compliant software such as Adobe PhotoDeluxe or Adobe Photoshop. The first time you scan with your SF-430, you will need to select it as your TWAIN source in the application you will use.

The basic scanning process involves a number of steps:

- Placing your photo or page on the document glass.
- Opening an application (such as PhotoDeluxe or Photoshop).
- Opening the TWAIN window and setting scan options.
- Scanning and saving your scanned image.

You have to follow the program's instructions for acquiring an image. Please refer to the application user's guide.



4.6

SCAN

5

FAX

This chapter includes:

- **Sending a Fax**
- **Receiving a Fax**
- **Automatic Dialling**
- **Advanced Faxing**
- **Additional Feature**

Sending a Fax

Preparing Documents for Faxing

Use the following guidelines to prepare your documents for faxing:

- Do not attempt to feed the following types of documents into the Automatic Document Feeder:
 - carbon-paper or carbon-backed paper
 - coated paper
 - onion skin or thin paper
 - wrinkled or creased paper
 - curled or rolled paper
 - torn paper
- Remove all staples and paper clips before feeding the document.
- Make sure any glue, ink or correction fluid on the paper is completely dry before loading the document.
- Do not load documents containing different sizes or weights of paper.

Acceptable Documents (for ADF¹)

		Single Sheet	2 or More Sheets
Document Size	Max.	8.5 in. (W) x 14 in. (L) (216 mm x 356 mm)	8.5 in. (W) x 11.7 in. (L) (216 mm x 297 mm)
	Min.	5.8 in. (W) x 5.0 in. (L) (148 mm x 128 mm)	
Effective Scanning Width		8.26 in. (210 mm)	
Number of sheets which can be loaded at a time			Up to 30
Thickness of document		0.05 mm ~ 0.07 mm 0.15 mm ~ 0.2 mm	0.075 mm ~ 0.12 mm
Print Quality		Uncoated on both sides	

1.ADF stands for Automatic Document Feeder. It allows you to stack original documents, which will be faxed or copied one by one.

Adjusting Document Settings

When setting typical text based documents, the default document settings produce good results.

However, if you send documents that are of poor quality, or contain photographs, you can adjust the following features to ensure a higher quality.

Resolution

Resolution is a measure of the fineness of clarity of a printout. Low resolution may cause text and graphics to have a jagged appearance, while higher resolutions provide smoother curves and lines, crisp text and graphics, and a better match to traditional typeface designs.

Press **Resolution** on the front panel to increase resolution. By pressing **Resolution** repeatedly or using the **Scroll** buttons (◀ or ▶), you can choose between STANDARD, FINE, and SUPERFINE. Press **Enter** to save the selection.

The document types recommended for quality settings are described below.

- **Standard** works well for normal handwritten typed, or printed documents.
- **Fine** is good for documents containing a lot of detail.
- **Superfine** works well for documents containing extremely fine detail. Superfine works only if the receiving machine also has the SUPERFINE feature.



NOTES:

- Superfine resolution is not available to store the document. Superfine documents will be stored to memory with Fine mode for the advanced faxing like delayed transmission. And for a normal fax, the pages will be sent one by one as soon as they are scanned, even though Send From Memory is set to ON.
 - If the product is set to Superfine resolution and the receiving fax machine does not support Superfine resolution, your product will transmit using the highest resolution mode supported by the remote fax machine.
-

Contrast

Contrast is the difference in brightness between the lightest and darkest parts of a printed document. You can adjust the contrast your product will use to send faxes. Adjust according to how light or dark your document is.

Press **Contrast** on the front panel to compensate for the brightness or darkness of your faxed document. By pressing **Contrast** repeatedly or using the **Scroll** buttons (◀ or ▶) after loading a document, you can choose between LIGHTEN, PHOTO, DARKEN, or NORMAL. Press **Enter** to save the selection.

- **Lighten** works well with dark print.
- **Photo** is used when faxing photographs or other documents containing shades of grey.



NOTE: The Photo setting is only enabled when sending a black and white fax. If you select the Photo setting and try to fax documents with colour images, the contrast will be set to 'NORMAL' automatically.

- **Darken** works well with light print or faint pencil markings. The light image and text on the original document will be darker on the printed page.
- **Normal** works well with standard typed or printed documents.

Setting Default Resolution and Contrast

You can set the default document settings including contrast and resolution. The default mode will be used when a document is sent unless you change the setting for individual operation.

- 1** Press **Setup**. The display shows "1.SYSTEM SETUP" on the bottom line.
- 2** Press **Enter**.
- 3** Press the **Scroll** buttons (◀ or ▶) until you see "SET DEFAULT".
- 4** Press **Enter**. The display shows the first option "CONTRAST".
- 5** To set the default contrast, press **Enter**.

Or,

To set the default resolution, press the **Scroll** buttons (◀ or ▶) until you see "RESOLUTION" and then press **Enter**.
- 6** Press the **Scroll** buttons (◀ or ▶) until you see the desired mode in the display.
- 7** Press **Enter** to save the selection.
- 8** Press **Cancel/Reset** to return to Standby mode.

Loading Document

- 1** Load the top edge of your document face down in the document feeder.
- 2** Adjust the document guides to match the width of the document.
- 3** Slide the sheet down into the document tray until it's gripped by the product.

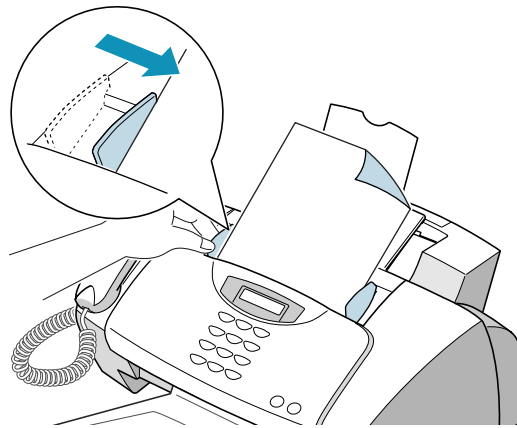

The automatic document feeder seizes and pulls the page in. The display shows "DOCUMENT READY" and the remaining memory capacity.

You can insert up to 30 sheets (75 g/m² Paper) at a time. If you insert more than one sheet, make sure the bottom sheet enters first. Stagger the leading edge of the sheets slightly, and insert the sheets with a slight push to ensure smooth feeding.

To add pages while the fax is sending, insert them into the loading slot on top of the already loaded sheets.

- 4** If necessary, use the **Resolution** button to change the resolution and the **Contrast** button to change the contrast. For details, see page 5.3.

Sending a Fax Automatically

- 1** Load the top edge of your document face down in the document feeder.
- 2** You can adjust the document settings to suit your fax needs. For details, see "Adjusting Document Settings" on page 5.3.

- 3** Enter the phone number of the remote fax machine using the number keypad.

If you make a mistake while entering a number, move the cursor under the wrong digit by using the **Scroll** buttons (◀ or ▶), and enter the correct number or press **Search/Delete** to delete the number.

- 4** When the number is correct, press **Start FAX Black** to send a black and white fax or **Start FAX Color** to send a colour fax. The product dials the number and begins to transmit.

Sending a Fax Using Manual Dial

- 1** Load the top edge of your document face down in the document feeder.
- 2** You can adjust the document settings to suit your fax needs. For details, see page 5.3.
- 3** Press **OHD/V.Req** on the front panel or lift the handset on the product. You hear a dial tone if the telephone line is correctly connected.
- 4** Enter the remote fax phone number using the number keypad.

- 5 When you hear the fax tone from the remote machine, press **Start FAX Black** to send a black and white fax or **Start FAX Color** to send a colour fax.

Sending a Fax After Talking

You can send a fax after speaking with a person at the remote site.

- 1 When finished talking, instruct the person at the remote location to start their fax machine and hang up.

The remote fax machine will send the initial fax tones.

- 2 Wait until you hear the fax tone from the remote fax machine.
- 3 Slide the document into the document feeder.
- 4 Press **Start FAX Black** to send a black and white fax or **Start FAX Color** to send a colour fax and replace your handset.

Cancelling a Fax

To cancel a fax, press **Cancel/Reset** at any time during the transmission.

Confirming Transmission

When the last page of your document has been sent successfully, the product beeps and returns to Standby mode.

If something went wrong during your fax transmission, an error message appears on the display. For a listing of error messages and their meanings, see page 7.6.

If you receive an error message, press **Cancel/Reset** to clear the message and try to send the document again.

You can set your product to print out a confirmation report automatically each time sending is completed. For details, see "Sending Confirmation" on page 5.36.

Automatic Redial

When you send a fax, if the number you have dialled is busy or there is no answer, the product will automatically redial the number every three minutes up to 5 times (factory default).

The display shows "RETRY REDIAL?" to redial the number without waiting, press **Enter**. To cancel the automatic redial, press **Cancel/Reset**.

You can change the time between redials and the number of redial attempts using the Fax Setup options. See page 5.40 and page 5.41 respectively.

Redialling

The memory in your product retains the last 10 numbers called, and the last 30 numbers received, provided the CLI (Caller Line Identification) Service is available.



NOTE: The CLI Service may be unavailable depending on your area or country.

Dialling the Last Number You Dialed

To redial the number last called:

- 1 Press **Redial/Pause**. The display shows the last number you dialed.
- 2 Lift the handset to make a call.

If a document is loaded in the document feeder, press **Start FAX Black** for black and white faxing, or **Start FAX Color** for colour faxing when the display shows "PRESS FAX BLACK OR COLOR".

To search through the Redial memory:

- 1 Press and hold **Redial/Pause** for 2 seconds. The display shows "Redial" on the bottom line.
- 2 Press **Enter**. The display shows the last number you dialed.

If you have dialled the same number multiple times, the product does not count the duplicates.

- 3 Press the **Scroll** buttons (◀ or ▶) to search through the memory until you see the number you want to dial.
- 4 Press **Enter**.
- 5 Lift the handset to make a call.

If a document is loaded in the document feeder, press **Start FAX Black** for black and white faxing, or **Start FAX Color** for colour faxing when the display shows "PRESS FAX BLACK OR COLOR".

Dialling the Number You Received

- 1** Press and hold **Redial/Pause** for 2 seconds. The display shows "Redial" on the bottom line.
- 2** Press the **Scroll** buttons (◀ or ▶) to select "CALLER ID" and then press **Enter**.
- 3** Press the **Scroll** buttons (◀ or ▶) to search through the memory until you see the number you want to dial.
- 4** Press **Enter**.
- 5** Lift the handset to make a call.

If a document is loaded in the document feeder, press **Start FAX Black** for black and white faxing, or **Start FAX Color** for colour faxing when the display shows "PRESS FAX BLACK OR COLOR".

Voice Request

5

If you are sending or receiving a document and need to speak to the other person during the same phone call, use Voice Request to alert the person at the remote site. You can also respond to a Voice Request made by the person at the remote end.

Sending a Voice Request

- 1** Press **OHD/V.Reg** while a document is being sent or received. A voice request signal is stored and then sent to the remote fax machine after the document has been sent or received. "VOICE REQUEST" is seen in the display.
- 2** When the phone rings, pick up the handset and answer it.

You can cancel a Voice Request by pressing **OHD/V.Reg** again while you are sending or receiving a document. "VOICE REQUEST" disappears from the display.

FAX **5.11**

Answering a Voice Request

When the phone rings after sending or receiving a fax, pick up the handset and answer it.

If you do not answer the Voice Request, the product prints out the number that made the Voice Request, as well as the time and date that the request was made.

Using the Toll Save Transmission

If you have set a specific toll save time using the FAX SETUP menu (see page 5.40), you can quickly set your document(s) to be sent at the preset time using the **SAVE Toll** button on the front panel. Using this feature, you can take advantage of lower long distance rates at night, for example.

- 1** Load the document(s) face up into the ADF until "DOCUMENT READY" appears in the display.
- 2** You can adjust the resolution and the contrast to suit your fax needs. For details, see page 5.3.
- 3** Press **SAVE Toll**. The display prompts you to enter the fax number.



NOTE: If you have not set a toll save time, specify the time in the Fax Setup menu first.

- 4** Enter the number of the remote fax machine using the number keypad.

You can also use a one-touch button or press **Speed** then use a 2-digit speed dial number.

- 5** Press **Enter** to confirm the number.

- 6 The display asks you to enter another fax number to send the document.
- 7 Select "1.YES" by pressing **1** and repeat from step 4 to enter another fax number.

Note that you cannot use Group dial numbers for another fax number.

- 8 To send to one location or when you complete the last fax number setting, select "2.NO" by pressing **2** in the "ANOTHER FAX NO.?" screen.
- 9 Press **Enter**. The document is scanned into memory with Black and White mode and the display shows a reminder that a toll save transmission is reserved at the preset time.



20-OCT 10:30 AM
SAVE TOLL 23:45

Transmission will be start at 11:45 PM.



NOTES:

- You cannot use a colour fax for a toll save transmission.
 - To cancel the job reserved in memory, see "Cancelling a Scheduled Operation" on page 5.35.
-

Receiving a Fax

About Reception Modes

Your product has four reception modes:

- In FAX mode, the product answers an incoming call and immediately goes into receive mode.
- In AUTO mode, the product answers an incoming call expecting to receive a fax. If the product does not sense a fax signal, it will continue to sound the ringing tone to tell you it is a phone call. If you do not lift the handset during the ringing, the product will switch to automatic fax reception mode.
- In ANS/FAX mode, an answering machine answers an incoming call, and the caller can leave a message on the answering machine. If your product senses a fax tone on the line, the call automatically switches to the fax machine.



NOTE: To use the ANS/FAX mode, attach an answering machine to the EXT jack on the back of your product (see page 1.9).

- In TEL mode, the automatic fax reception is turned off. You can receive a fax by picking up the handset and pressing **Start FAX Black** or **Start FAX Color** on the front panel of your SF-430 series product.
- In DRPD mode, you can receive a call using the Distinctive Ring Pattern Detection (DRPD) feature. "Distinctive Ring" is a telephone company service which enables a user to use a single telephone line to answer several different telephone numbers. This mode is displayed when you have set up the distinctive ring pattern. For details on this feature, see page 5.41.

The current reception mode is displayed when the product is in Standby mode.



If you seldom use the fax line for voice conversations, set your product to receive a fax automatically by selecting FAX mode.



NOTE: While the product is printing a received document, scanning for fax or copy job is not possible. After the current print job is completed, try the job.

Loading Paper for Receiving Faxes

The instructions for loading paper in the paper input tray are the same whether you are printing, faxing, or copying, except that faxes can only be printed on letter-, A4-, or legal-sized paper. See "Loading Paper" on page 1.11 for instructions.

After loading paper for receiving faxes, set the paper size to the size of paper you normally load in the paper bin. Your product uses this setting when printing reports and determining auto reduction for incoming faxes. See page 5.39 to set the paper size.



NOTE: The FAX PAPER SIZE setting does not affect the printing from PC. If you are loading special-sized media for your current print job, do not change this setting. After you have finished printing, reload the original paper for fax printing.

Receiving Automatically in FAX Mode

Your product is preset to FAX mode at the factory. If you have changed the receive mode, take the following steps to receive faxes automatically:

- 1** Press **Receive Mode** on the front panel repeatedly until you see "FAX". Then, press **Enter**.
- 2** When you receive a call, the product answers the call on a specified number of rings and receives a fax automatically. To change the number of rings, see "Fax Setup Options" on page 5.38.

To adjust the ringer volume, see "Setting Sounds" on page 1.41.

Receiving in AUTO Mode

- 1** Press **Receive Mode** on the front panel repeatedly until you see "AUTO". Then, press **Enter**.
- 2** When you get a call, the product answers it.

If a fax is being sent, the product goes into reception mode.

If the product does not detect a fax signal, it will continue ringing to tell you it is a phone call. You should pick up the handset to answer the call, or it will switch to automatic reception mode.

Receiving Automatically in ANS/ FAX Mode

For this mode, you must attach an answering machine to the EXT jack on the back of your product (see page 1.9).

- 1** Press **Receive Mode** on the front panel repeatedly until you see "ANS/FAX". Then, press **Enter**.
- 2** When you receive a call, the answering machine will answer.

If the caller leaves a message, the answering machine stores the message as it would normally. If your product hears a fax tone on the line, it automatically starts to receive the fax.



NOTES:

- If you have set your product to ANS/FAX mode and your answering machine is switched off, or no answering machine is connected to your product, your product will automatically go into FAX mode after predefined rings. The ring count may vary depending on your country.
 - If your answering machine has a 'user-selectable ring counter', set the product to answer incoming calls within 1 ring.
 - If you are in TEL mode (manual reception) when the answering machine is connected to your product, you must switch off the answering machine, or the outgoing message from the answering machine will interrupt your phone conversation.
-

Receiving Manually in TEL Mode

You can answer calls using the handset, and start the product to receive a fax.

- 1** Press **Receive Mode** on the front panel repeatedly until you see "TEL". Then, press **Enter**.
- 2** When the telephone rings, pick up the handset and answer it.
- 3** If you hear a fax tone, or if the person on the other end asks you to receive a document, press **Start FAX Black** or **Start FAX Color**.
- 4** Replace the handset. The product begins receiving and returns to Standby mode when the reception is complete.

Receiving Manually Using an Extension Telephone

This feature works best when you are using an extension telephone connected to the EXT jack on back of your product (see page 1.9). You can receive a fax from someone you are talking to on the extension telephone without having to go to the fax machine.

When you receive a call on the extension phone and hear fax tones, press the keys **"*9*"** (star nine star) on the extension telephone.

The product receives the document.

Press the buttons slowly in sequence. If you still hear the fax tone from the remote machine, try pressing **"*9*"** once again.

"*9*" is the remote receive start code preset at the factory. The first and the last asterisks are fixed, but you can change the middle number to whatever you choose. For more information, see page 5.41.

Receiving Using DRPD Feature

You can not set 'DRPD (Distinctive Ring Pattern Detection)' as the receive mode using the **Receive Mode** button on the front panel if you have not set up your product for use with the DRPD service and turned on the feature (see page 5.41).

When the receive mode is set to "DRPD," if someone calls using the number assigned for telephone communication, your product rings in the pattern you registered for voice calls. When you hear this pattern, simply pick up the handset of the telephone connected to your product and talk.

When someone sends a fax using the number assigned for fax communication, your product receives the fax automatically.

You can select the other receive mode using **Receive Mode** button on the operation panel to temporarily disable the DRPD service.

Receiving in Colour

Your product has been set to receive faxes in colour from fax machines with colour capability. When receiving a fax, your product detects if the incoming fax is in colour or black and white, and prints the fax accordingly.

Receiving Fax in Memory

Since your product is a multitasking device, it can receive faxes while you are making copies or printing. If you receive a fax while you are copying or printing, your product stores the incoming fax in memory. Then, as soon as you finish copying or printing, the product automatically prints the fax.

Forwarding Received Faxes

You can set your product to forward incoming faxes to another fax number during a specified time period. When the fax arrives at your product, it is stored in memory. Then, your product dials the fax number you have specified and sends the fax.

If it cannot forward a fax after repeated attempts because of an error, such as the number being busy and redials failing, your product will print a message confirmation report showing the result of the transmission. If it runs out of memory while receiving a fax, it will terminate the incoming fax and only forward the partial pages already stored in memory.

You can also select the fax forwarding option which allows you to print the fax on your product if fax forwarding is completed without an error.

To use fax forwarding, take the following steps:

- 1** Press **FAX Forward**.
- 2** Select the fax forwarding option by pressing **FAX Forward** or using the **Scroll** buttons (◀ or ▶). The following options are available:
 - **OFF**: turns the fax forwarding off.
 - **FORWARD**: forwards the fax to a specified number. Your product does not print the fax.
 - **FORWARD & PRINT**: forwards the fax to a specified number and prints the fax on your product.
- 3** Press **Enter** to save the selection.
- 4** If you choose to forward faxes, enter the fax number where you would like the fax to go, and then press **Enter** to save your selection.
- 5** Enter the date using the number keypad you want to start forwarding incoming faxes and then press **Enter**.

- 6** Enter the time using the number keypad you want to start forwarding incoming faxes and then press **Enter**.
- 7** Enter the date using the number keypad you want to end forwarding incoming faxes and then press **Enter**.
- 8** Enter the time using the number keypad you want to end forwarding incoming faxes and then press **Enter**.
- 9** The display shows "FW" at the left side of the receiving mode, for example "FW FAX" at the bottom right corner to indicate that the fax forwarding feature is activated.

When the time you have set to start forwarding is up, the display shows "FORWARDING".

Automatic Dialling

One-Touch Dialling

One-Touch dialling lets you use any of the 10 one-touch buttons to automatically dial a number.

Storing a Number for One-Touch Dialling

- 1** Press and hold one of ten one-touch buttons for more than 2 seconds. The display shows "Txx:", where xx represents the selected one-touch button number.

If a number is already stored in the location you chose, the display shows the number. To replace the number with other phone number, select "1.RENEW". Otherwise, select "2.OTHER" and start over with a different one-touch button.

- 2** Enter the number you want to store by using the number keypad and then press **Enter**.

To insert a pause between numbers, press **Redial/Pause**. 'P' appears on the display.

If you make a mistake while entering a number, press **Search/Delete** and re-enter the correct number.

- 3** To assign a name to the number, enter the desired name. For information on how to enter names, see "Entering Characters Using the Number Keypad" on page 1.38.

Or,

If you do not want to assign a name, skip this step.

- 4** Press **Enter** when the name appears correctly or simply without entering a name.

- 5 To store more telephone numbers, press another one-touch button and repeat steps 2 through 4.

Or

To return to Standby mode, press **Cancel/Reset**.

Sending a Fax using a One-Touch Number

- 1 Load the document(s) face down into the ADF. "DOCUMENT READY" appears in the display.
- 2 You can adjust the resolution and the contrast to suit your fax needs. For details, see page 5.3.
- 3 Press the one-touch button where you stored a number.
- 4 Press **Start FAX Black** to send a black and white fax or **Start FAX Color** to send a colour fax.

The fax number stored in the one-touch dial location will be automatically dialled, and the document will be sent when the remote fax machine answers.

Speed Dialling

You can store up to 90 numbers in the 2-digit Speed Dial locations (01-90).

Storing a Number for Speed Dialling

- 1 Press and hold **Speed** for 2 seconds.
- 2 Enter a speed dial number using the number keypad and then press **Enter**.

If a number is already stored in the location you chose, the display shows the number. To replace the number with other phone number, select "1.RENEW". Otherwise, select "2.OTHER" and start over with a different speed dial number.

- 3** Enter the number you want to store, and press **Enter**.
- 4** To assign a name to the number, enter the desired name. For details on how to enter names, see "Entering Characters Using the Number Keypad" on page 1.38.

Or

If you do not want to assign a name, skip this step.
- 5** Press **Enter** when the name appears correctly or simply without entering a name.
- 6** To store more telephone numbers, repeat steps 2 through 5.

Or

To return to Standby mode, press **Cancel/Reset**.

Sending a Fax using a Speed Dial Number

- 1** Load the document(s) face down into the document feeder. "DOCUMENT READY" appears in the display.
- 2** You can adjust the resolution and the contrast to suit your fax needs. For details, see page 5.3.
- 3** Press **Speed**.
- 4** Enter the speed dial number using the number keypad.

You can scroll through the numbers stored in memory by using the **Scroll** buttons (◀ or ▶).
- 5** When the desired number appears in the display, press **Enter**.
- 6** Press **Start FAX Black** to send a black and white fax or **Start FAX Color** to send a colour fax.

The fax number stored in the speed dial location will be automatically dialed and the document will be sent when the remote fax machine answers.

Group Dialling

If you frequently send the same document to several destinations, you can create a group of these destinations and set them under a one-touch button. This enables you to press a single one-touch button to send the same document to all the destinations in the group.



NOTE: You can only group numbers that have already been registered for speed dialling.

Setting Group Dial

- 1 Press **Setup**. The display shows "1.SYSTEM SETUP" on the bottom line.
- 2 Press the **Scroll** buttons (◀ or ▶) until you see "6.GROUP SET" and then press **Enter**. The display prompts you to select a one-touch button.
- 3 Press the one-touch button under which you want to register the group and then press **Enter**.



NOTE: If the one-touch button has already been registered for one-touch dialling or another group, the display prompts you to renew the selected one-touch button or select another one-touch button. Select "1:RENEW" to delete the contents in the selected one-touch button and continue, or "2:OTHER" to keep the the contents and start over with a different one-touch button.

- 4 The selected group number appears in the display and the display prompts you to confirm the number. Press **Enter** to accept "1:YES". If you select "2:NO", the selected one-touch button will be cancelled and you can start over with another one-touch group number.
- 5 The display prompts you to enter a speed dial number. Enter the 2-digit speed dial number you want to include in the group and then press **Enter**.

- 6** Repeat step 5 to enter another speed dial number into the group.
- 7** When you have entered all the desired numbers, press **Cancel/Reset**. The display prompts you to enter a name.
- 8** If you want to assign a name to the group, enter the desired name.

Or, skip this step.
- 9** Press **Enter** after you enter the name or without entering the name.
- 10** If you want to assign another group, repeat from step 3.

To return to Standby mode, press **Cancel/Reset**.

Sending a Fax Using Group Dialling (Multi-Address Transmission)

You can use Group Dialling for broadcasting, delayed fax, or toll save transmission.

Follow the procedure of the desired operation (broadcasting - page 5.28, delayed fax - page 5.29, toll save transmission - page 5.12). When you come to a step in which the display requests you to enter the remote fax number, press the one-touch button assigned to a group. You can use only one group number for one operation. Then continue the procedure to complete the desired operation.

Your product automatically scans the document loaded in the document tray into the memory, and the product will dial each of the numbers included in the Group.

Searching for a Number in the Memory

There are two ways to search for a number in the memory. You can either scan from A to Z sequentially, or you can search using the first letter of the name associated with the number.

Searching Sequentially through the Memory

- 1 Press **Search/Delete**.
- 2 Press the **Scroll** buttons (◀ or ▶) to scroll through the memory until you see the name and number you want to dial. You can search downward or upward through the entire memory in alphabetical order (from A to Z).

While searching through the product's memory, you will see that each entry is preceded by one of three letters: "T" for one-touch dial, "S" for speed, or "G" for group dial number. These letters tell you how the number is stored.

- 3 When the name and number you want appears on the display, press **Enter** to dial.

5

Searching with a Particular First Letter

- 1 Press **Search/Delete**.
- 2 Press the button labelled with the letter you want to search for. A name beginning with the letter appears on the display.

For example, if you want to find the name 'MOBILE', press the **6** button, which is labelled with 'MNO.'

- 3 Press the **Scroll** buttons (◀ or ▶) to display the next name in the list.
- 4 When the name and number you want appear, press **Enter** to dial.

Advanced Faxing

Broadcasting

Documents are automatically stored in memory and sent to a remote station. Use this feature to send your documents to multiple locations. After sending, the documents are automatically erased from the memory.



NOTE: You can not use colour mode in broadcast mode.

- 1** Load the document(s) face down into the document feeder. "DOCUMENT READY" appears in the display.
- 2** You can adjust the resolution and the contrast to suit your fax needs. For details, see page 5.3.
- 3** Press **Setup**.
- 4** Press the **Scroll** buttons (◀ or ▶) until you see "4.ADVANCED FAX" and then press **Enter**.
- 5** The display shows the first menu "BRAODCASTING". Press **Enter**.
- 6** Enter the phone number of the remote fax machine using the number keypad.

You can also use a one-touch button or press **Speed** then use a 2-digit speed dial number.
- 7** Press **Enter** to confirm the number. The display asks you to enter another fax number to send the document too.
- 8** Select "1.YES" by pressing **1** and repeat from step 6 to enter another fax number.

Note that you cannot use Group dial numbers for another fax number.

- 9 To send to one location or when you complete the last fax number setting, press **2** to select "2.NO" in the "ANOTHER FAX NO.?" screen.
- 10 The document(s) will be scanned into the memory before transmission.

The display shows the memory capacity and the number of pages being stored in the memory and then the product begins sending the document in order you entered the numbers.

Delayed Fax

You can set your product to send a fax at a later time, for example when you will not be there.



NOTE: You can not use colour mode for delayed faxing.

- 1 Load the document(s) face down into the document feeder. "DOCUMENT READY" appears in the display.
- 2 You can adjust the resolution and the contrast to suit your fax needs. For details, see page 5.3.
- 3 Press **Setup**.
- 4 Press the **Scroll** buttons (◀ or ▶) until you find "4.ADVANCED FAX" and then press **Enter**.
- 5 Press the **Scroll** buttons (◀ or ▶) until you see "DELAYED FAX" and then press **Enter**.
- 6 Enter the phone number of the remote fax machine using the number keypad.

You can also use a one-touch button or press **Speed** then use a 2-digit speed dial number.

7 Press **Enter** to confirm the number. The display asks you to enter another fax number to send the document too.

8 Select "1.YES" by pressing **1**, and repeat from step 6 to enter another fax number.

Note that you cannot use Group dial numbers for another fax number.

9 To send to one location or when you complete the last fax number setting, press **2** to select "2.NO" in the "ANOTHER FAX NO.?" screen.

10 The display asks you to enter a name. If you want to assign a name to the transmission, enter the name. If not, skip over this step.

For details on how to enter the name using the number keypad, see "Entering Characters Using the Number Keypad" on page 1.38.

11 Press **Enter**. The display shows the current time and asks you to enter the start time when the fax is to be sent.

12 Enter the time by using the number keypad.

If you set a time earlier than the current time, the document will be sent at that time on the following day.

13 Press **Enter** when the start time on the display is correctly.

14 The document will be scanned into the memory before transmission.

The display shows the memory capacity and the number of pages being stored in the memory.

The product returns to Standby mode and the display reminds you that you are in Standby mode and that Delayed Transmission is set.



NOTE: If you want to cancel the Delayed Fax, see "Cancelling a Scheduled Operation" on page 5.35.

Priority Fax

When priority sending is enabled, a high priority document can be transmitted ahead of reserved operations. The document is scanned into the memory, then transmitted when the current operation is concluded. In addition, the Priority Send will interrupt a broadcast operation between stations (i.e., when transmission to station A ends, before transmission to station B begins) or between redial attempts.



NOTE: You cannot use colour mode for priority faxing.

- 1** Load the document(s) face down into the document feeder. "DOCUMENT READY" appears in the display.
- 2** You can adjust the resolution and the contrast to suit your fax needs. For details, see page 5.3.
- 3** Press **Setup**.
- 4** Press the **Scroll** buttons (◀ or ▶) until you see "4.ADVANCED FAX" and then press **Enter**.
- 5** Press the **Scroll** buttons (◀ or ▶) until you see "PRIORITY FAX" and then press **Enter**.
- 6** Enter the phone number of the remote fax machine using the number keypad.

You can also use a one-touch button or press **Speed** then use a 2-digit speed dial number.

- 7** Press **Enter** to confirm the number. The display asks you to enter a name.
- 8** If you want to assign a name to the transmission, enter the name. If not, skip over this step.

For details on how to enter a name using the number keypad, see "Entering Characters Using the Number Keypad" on page 1.38.

- 9 Press **Enter**. The document(s) will be scanned into the memory before transmission.

The display shows the memory capacity and the number of pages being stored in the memory.

- 10 The product shows the number being dialled and then begins sending the document.

Polling

Polling is used when one fax machine requests another to send a document. This is useful when the person with the original document to be sent is not in the office. The person who wants to receive the document calls the fax machine holding the original and requests that the document be sent. In other words, it "polls" the machine holding the original.

Polling Transmission

You can program your product to send documents in your absence when polled by a remote fax machine. It is possible to use a poll code to prevent unauthorized polling of your product. When you secure your product in this manner, only those who know the poll code can poll your product.



NOTE: You cannot use colour mode for polling transmission.

- 1 Load the document(s) face down into the document feeder. "DOCUMENT READY" appears in the display.
- 2 You can adjust the resolution and the contrast to suit your fax needs. For details, see page 5.3.
- 3 Press **Setup**.
- 4 Press the **Scroll** buttons (◀ or ▶) until you see "4.ADVANCED FAX" and then press **Enter**.

- 5 Press the **Scroll** buttons (◀ or ▶) until you find "SEND POLLING", and then press **Enter**.

The display asks you to enter a 4-digit poll code. The poll code is preset to "0000" at the factory, which represents no poll code.

- 6 If you want to use a poll code, enter the desired 4-digit code (except for "0000") and then press **Enter**.

Or

If you do not want to secure the transmission with a poll code, press **Enter** when the display shows "0000" for the poll code, or enter **0000**.

- 7 The product stores the document in the memory. The display counts the number of pages being stored in the memory and the memory capacity remaining.

The product returns to Standby mode and the display shows a reminder that "POLL TX" is set.



NOTE: If you have previously set the receive mode to other than FAX mode, the product automatically switches to FAX mode (automatic receiving) when set to be polled.

5

Polling a Remote Machine

Your product will poll a remote fax machine and retrieve a document, which is stored in memory and then print it.

- 1 Lift the handset or press **OHD/V.Reg** on the front panel, and enter the phone number of the remote fax machine.
- 2 When you hear a fax tone from the remote machine, press **Setup**.
- 3 When the display shows "TO RX POLL PRESS ENTER", Press **Enter**.

The display asks you to enter a 4-digit poll code. The poll code is preset to "0000" at factory. 0000 represents no code.

- 4 If the remote machine is secured with a Poll code, you must enter the correct code and then press **Enter**.

Or

If the remote machine is not secured with a Poll code, just press **Enter** to accept "0000".

- 5 Your product starts to receive the document from the remote fax machine.

Adding Documents To a Scheduled Operation

You can add documents to a transmission previously reserved in your product's memory.

- 1 Load the document(s) face down into the document feeder. "DOCUMENT READY" appears in the display.
- 2 You can adjust the resolution and the contrast to suit your fax needs. For details, see page 5.3.
- 3 Press **Setup**.
- 4 Press the **Scroll** buttons (◀ or ▶) until you see "4.ADVANCED FAX" and then press **Enter**.
- 5 Press the **Scroll** buttons (◀ or ▶) until you see "ADD SCHEDULE" and then press **Enter**.
- 6 Press the **Scroll** buttons (◀ or ▶) repeatedly until you see the operation to which you want to add documents on the display, then press **Enter**.
- 7 The product automatically stores the documents in the memory, and the display shows the memory capacity and the number of pages.

After storing, the product displays the number of total pages and then returns to Standby mode.

Cancelling a Scheduled Operation

- 1** Press **Setup**.
- 2** Press the **Scroll** buttons (◀ or ▶) until you see "4.ADVANCED FAX" and then press **Enter**.
- 3** Press the **Scroll** buttons (◀ or ▶) until you find "CANCEL SCHEDULE", and then press **Enter**.
- 4** Press the **Scroll** buttons (◀ or ▶) repeatedly until you find the operation you want to cancel and then press **Enter**.
- 5** The selected job is cancelled and the display returns to Standby mode.

Additional Feature

Printing Reports

Your product can print reports containing useful information – Schedule Job, System Data, etc. The following reports are available:

Help List

This list shows the product's basic functions and commands to use as a quick reference guide.

Sent Journal

This report shows information concerning transmission activities recently made.

Received Journal

This report shows information concerning reception activities recently made.

Phonebook

This list shows all of the numbers currently stored in the product's memory as one-touch dial numbers, speed dial numbers and group dial numbers.

Sending Confirmation

This report shows the fax number, the number of pages, elapsed time of the operation, the communication mode, and the communication results.

You can set up your product to print the message confirmation report in one of the following ways:

- Automatically after each transmission (ON)

- Automatically only if an error occurs during transmission (ERR)
- No report printed at all (OFF). You can print this report manually at any time you want.

Schedule Job Information

This list shows the document currently stored for Delayed Sending, Priority Sending, Group Sending, and TX polling. The list shows the starting time, type of operation, etc.

System Data List

This list shows the status of System Setup, Fax Setup, and Copy Setup options. After you change any setting, print this list to confirm your changes.

Self Test Page

This page shows the pattern indicating the status of the cartridge nozzle. You can check if the product is printing correctly using this page.

CID (Caller Identification) List

This list shows 30 last numbers you received if you have the Line Identification Service from the network. You can check the phone number of the caller and the date and time when the call was received.

Junk Fax List

This list shows the fax numbers defined as junk fax numbers by using the Junk Fax Setup menu (see page 5.43). When the Junk Fax Barrier feature is turned on, the incoming faxes from those numbers will be blocked.



NOTE: The list you have set to print out automatically will not print out when there is no paper loaded or a paper jam has occurred.

Other Reports

- Multi-Communication Report: This report is printed automatically after sending documents to more than one location.

- **Power Failure Report:** This report is printed out automatically when power is restored after a power failure if there occurs any data loss due to the power failure.

Printing List

- 1** Press **Setup**.
- 2** Press the **Scroll** buttons (◀ or ▶) repeatedly until you see "5.REPORT/HELP", and press **Enter**.
- 3** Press the **Scroll** buttons (◀ or ▶) repeatedly until you find the list you want to print.
- 4** When the desired list displays, press **Enter**. The selected list will be printed.

Fax Setup Options

Your product has various user-selectable setup options for the fax system. These options are preset at the factory, but you may need to change them. To find out how the options are currently set, print the System Data list. For details on printing the list, see above.

Setting an Option

- 1** Press **Setup**.
- 2** Press the **Scroll** buttons (◀ or ▶) until you see "2.FAX SETUP" and then press **Enter**.
- 3** The display shows the first setup option "SEND FROM MEMORY". Scroll through the options by pressing the **Scroll** buttons (◀ or ▶).
- 4** When you see the option you want on the display, press **Enter**.

- 5** Choose the desired status by pressing the **Scroll** buttons (◀ or ▶) or enter the desire number using the number keypad.
- 6** Press **Enter** to save the selection.
- 7** Repeat from step 1 to set other data options if necessary. You can exit from setup mode at any time by pressing **Cancel/Reset**.

Selectable Options

These instructions assume you've followed the steps under "Setting an Option" on page 5.38 and the product is prompting you to change one of the options listed here.

- **SEND FROM MEMORY** : If you are annoyed that you have to wait until documents in the ADF are sent out when you try to send or reserve another fax, turn this feature on. With this feature enabled, all transmission documents are automatically scanned into memory before transmission.

Select ON to turn this feature on. Note that this feature will be disabled for colour faxing.

Select OFF to turn this feature off.

- **SENDING CONFIRM** : A message confirmation report shows whether the transmission was successful or not, how many pages were sent, etc.

Select ON to print a confirmation report automatically each time you send a fax.

Select OFF to turn this feature off.

Select ERROR to print only when an error occurs and the transmission was not successful.

- **FAX PAPER SIZE** : Select the paper size you will use for the recording paper. Sizes available are: LETTER, A4, LEGAL.

- **AUTO REDUCTION:** When receiving a document as long or longer than the paper loaded in your product, the product can reduce the received data to fit into your recording paper size.

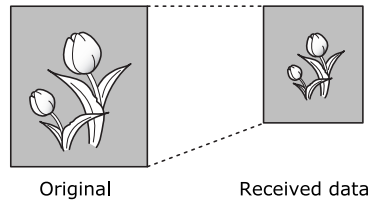

Turn this feature on to reduce an incoming page that may need to be divided into two pages with only a few lines on the second page. If the product cannot reduce the data to fit onto one page with this feature enabled, the data will be divided and printed in actual size on two or more sheets if necessary.

Select ON to enable. Note that this feature does not apply in copy mode.

Select OFF to turn this feature off. The overflow data will be discarded or printed out on a second page depending on the discard size setting (see page 1.40).

- **SAVE TOLL TIME:** You can set the start time for toll save transmission using the **SAVE Toll** button. For details on toll save transmission, see page 5.12.

Enter the desired time using the number keypad. You can toggle between AM and PM by pressing the **Scroll** buttons (◀ or ▶) repeatedly in 12-hour mode.

- **RINGS TO ANSWER :** You can select the number of times your product rings before answering an incoming call.

Enter a number using the number keypad.

- **REDIAL INTERVAL :** Your product automatically redials a remote fax machine if it was busy or does not answer on the first call.

Enter the number of minutes using the number keypad.

- **REDIAL COUNT:** Enter the number of attempts made to redial a number.

If you enter **0**, the product will not redial.

- **STAMP RCV. NAME :** Allows the product to automatically print the page number, and the date and time of the reception at the bottom of each page of a received document.

Select ON to turn this feature on.
Select OFF to turn this feature off.

- **RCV. START CODE :** The remote receive code allows you to initiate fax reception from an extension phone plugged into the EXT jack. If you pick up the extension phone and hear fax tones, enter the remote receive code and the fax will start receiving. The password is preset to * 9* at the factory.

Enter the desired code from **0** to **9** on the number keypad.

- **DRPD (Distinctive Ring Pattern Detection) MODE :** 'Distinctive Ring' is a telephone company service which enables a user to use a single telephone line to answer several different telephone numbers. The particular number someone uses to call you on is identified by different ringing patterns, which consist of various combinations of long and short ringing sounds. This feature is often used by answering services who answer telephones for many different clients and need to know which number someone is calling in on to properly answer the phone.

Using the Distinctive Ring Pattern Detection feature, your product can 'learn' the ring pattern you designate to be answered by the SF-430 product. Unless you change it, this ringing pattern will continue to be recognized and answered as a FAX call, and all other ringing patterns will be forwarded to the extension telephone or answering product plugged into the EXT jack. You can easily suspend or change Distinctive Ring Pattern Detection at any time.

Before using the Distinctive Ring Pattern Detection option, Distinctive Ring services must be enabled on your telephone line by the telephone company. To setup Distinctive Ring Pattern Detection, you will need another telephone line at your location, or someone available to dial your fax number from outside.

Select ON to turn this mode on.
Select OFF to turn this mode off.
Select SET to setup the Distinctive Ring Pattern Detection. The LCD displays "WAITING RING". Call your fax number from another telephone. When the product completes 'learning', the LCD displays "END DRPD SETUP".

With the DRPD feature active, "DRPD MODE" appears in the display and the previously set reception mode is ignored. If you turn DRPD off, the product returns to the previously set reception mode.



NOTES:

- DRPD must be set up again if you re-assign your fax number, or connect the product to another telephone line.
 - After DRPD has been set up, call your fax number again to verify that the product answers with a fax tone, then have a call placed to a different number assigned to that same line to be sure the call is forwarded to the extension telephone or answering product plugged into the EXT jack.
-

- **ECM MODE (Error Correction Mode)** : This mode compensates for poor line quality and ensures accurate, error-free transmission with any other ECM-equipped facsimile machine. If the line quality is poor, transmission time may be increased when ECM is enabled.

Select ON to turn the Error Correction mode on.
Select OFF to turn this Error Correction mode off.

- **AUTO JOURNAL** : A journal shows specific information concerning transmission or reception activities, the time and dates of up to 40 most recent transmissions or receptions.

Select ON to print the journal automatically after every 40 transmissions or receptions.
Select OFF to print the journal manually.

- **CALLER ID** : When you receive a call, you can see the number of the person calling you if you have Caller Line Identification Service from the network. (This option may not work when connected to a PABX.)

Select ON to display the caller ID.
Select OFF not to display the caller ID.



NOTE: The Caller ID option may be unavailable depending on your area or country.

- **JUNK FAX BARRIER**: With this feature set to ON, the system will not accept a fax sent from a remote station who's fax number is stored in memory as a junk fax number via the Junk Fax Setup menu below.

Select ON to turn this feature on. You can not receive from stations identified as junk fax numbers.

Select OFF to turn this feature off. Anybody can send you a fax.

- **JUNK FAX SETUP** : You can register up to 20 desired fax numbers from the CID (Caller Identification) list as junk fax numbers. When the Junk Fax Barrier feature is turned on, the incoming faxes from those numbers will be blocked.

Select REGISTER to register a junk fax number. Press the **Scroll** buttons (◀ or ▶) to scroll through the CID list, and press **Enter** when the desired number is displayed.

Select DELETE to delete a registered junk fax number. Press the **Scroll** buttons (◀ or ▶) to scroll through the list and press **Enter** when the desired number is displayed.

Using the Fax Settings Utility

When you install the MFP driver, the Fax Settings Utility is automatically installed. With this program, you can configure the various fax setup options and store speed dial numbers from your computer. You can download this information to your SF-430 to make them effective on the front panel.

To install the MFP driver, see "Installing Samsung Software" on page 1.21.

Accessing the Fax Settings Utility

- 1 Click **Start > Programs > SAMSUNG SF-430 Series > Fax Settings Utility**.

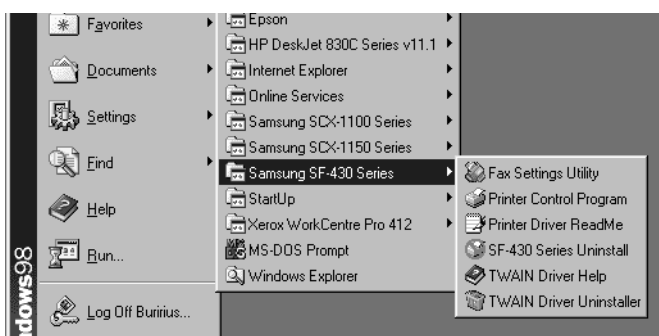

▲ In case of Windows 98

- 2 The Samsung SF-430 Fax Settings Utility dialogue box opens.

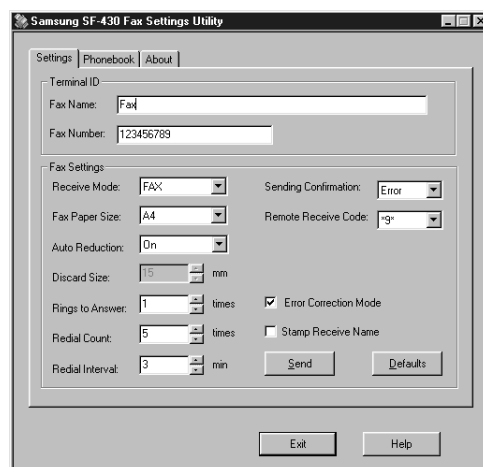

- 3 After using the Fax Settings Utility, click **Exit** to close the dialogue box.

You can get online help by clicking the **Help** button.

Settings Tab

Using the **Settings** tab, you can set up the fax name and number, and configure the fax setup options. For details on each setup option, see "Fax Setup Options" on page 5.38.

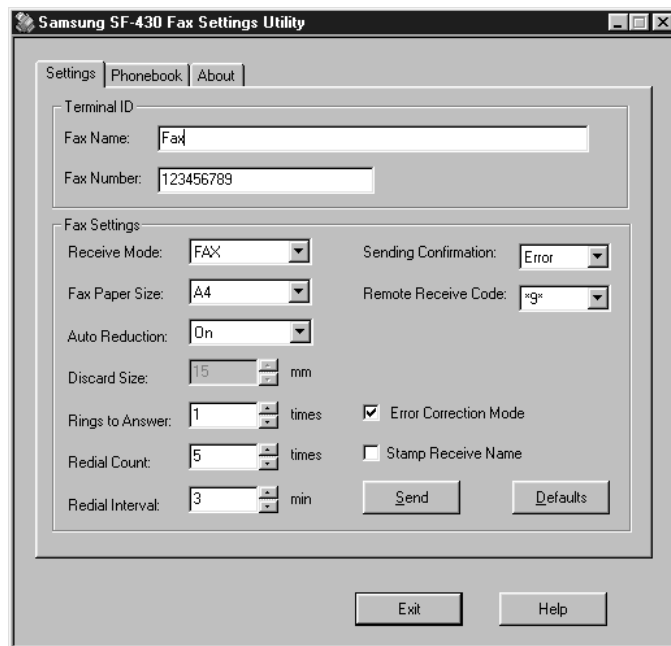

5

When configuration is complete, click **Send** to download the information to SF-430.

The **Defaults** button allows you to restore the default status of each item.

Phonebook Tab

Using the **Phonebook** tab, you can store speed dial numbers (for details on speed dialling, see page 5.23).

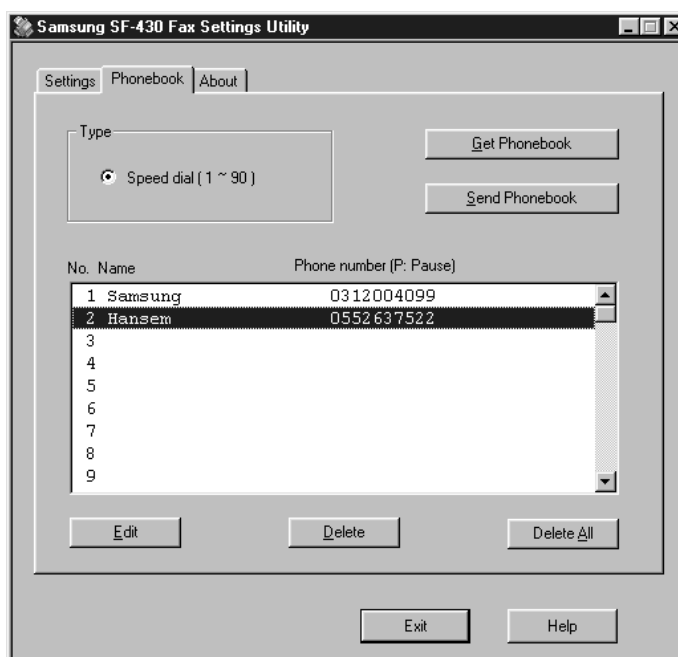

- **Get Phonebook:** gets the speed dial numbers stored in the memory of your product.
- **Send Phonebook:** sends the speed dial numbers to your product. After storing or deleting a speed dial number, you must click this button to make the changes effective on the front panel of your product.
- **Edit:** allows you to store or edit a speed dial number. After selecting the desired speed dial location from the list, click this button. Then, enter a name and number in the Edit - Speed dial #X dialogue box (where X designates the selected speed dial location), and click **OK** to save.
- **Delete:** deletes the selected speed dial number.
- **Delete All:** deletes all the speed dial numbers.

About Tab

The **About** tab gives you the program version number. If you click on the globe image on the bottom of the window, you will be connected to the Samsung web site provided you are on the internet.



6

MAINTENANCE

This chapter provides suggestions for high-quality and economical printing and information for maintaining the print cartridges and the product.

This chapter includes:

- **Maintaining Print Cartridges**
- **Viewing Ink Levels**
- **Cleaning the Print Cartridges**
- **Replacing the Print Cartridges**
- **Aligning the Print Cartridges**
- **Clearing Memory**
- **Adjusting Shading**
- **Setting the Product to be Checked by Phone**
- **Cleaning the Document Scanner**

Maintaining Print Cartridges

To get the maximum benefit from your print cartridges:

- Do not remove a print cartridge from its packaging until you are ready to install it.
- Do not refill the print cartridges. The warranty does not cover damage caused by using refilled cartridges.
- Store the print cartridges in the same environment as your equipment.
- Do not remove a print cartridge from the product except to replace, or clean. Immediately replace the print cartridge or store in the storage unit. The print cartridge will not print correctly if removed from your product and left exposed for an extended period of time.
- Your product will not print with only one print cartridge installed. If you do not have a new replacement for the empty print cartridge, leave the empty cartridge in the cartridge holder of the product.
- Do not swap the colour cartridge with the black cartridge. The colour cartridge should be installed in the Left carrier and the black cartridge should be installed in the Right carrier.
- If you have an opened ink cartridge you are not currently using and do not have an available print cartridge storage unit, store it in an airtight plastic bag. Do not leave it exposed to the air for an extended period; this promotes drying out and clogging of the print nozzles.

Viewing Ink Levels

You can view the ink level on the LCD display using the front panel buttons. Take the following steps:

- 1 Press **Setup**. The display shows "1.SYSTEM SETUP" on the bottom line.
- 2 Press the **Scroll** buttons (◀ or ▶) until you see "8.MAINTENANCE" and then press **Enter**.
- 3 Press the **Scroll** buttons (◀ or ▶) until you see "VIEW INK LEVEL" on the display and then press **Enter**.
- 4 The colour ink level and the black (or photo) ink level are displayed. The remaining ink is displayed as a fraction of the full capacity.

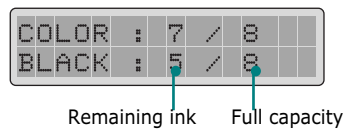

Cleaning the Print Cartridges

Cleaning your print cartridges can improve the quality of printing. If your printed page is missing lines or dots or contains ink streaks, clean the print cartridges as described in this section.

There are two methods to clean the print cartridges:

- Printing a head cleaning page, which can be done from the front panel of the SF-430 or from the Control Program on your computer screen.
- Clean the print cartridge nozzles.



NOTE: Do not clean the print cartridges unnecessarily, as this wastes ink and shortens the life of the print cartridge.



Printing a Cleaning Page from the SF-430

1 Press **Setup**. The display shows "1.SYSTEM SETUP" on the bottom line.

2 Press the **Scroll** buttons (◀ or ▶) until you find "8.MAINTENANCE" on the display, and press **Enter**.

The first maintenance option "CLEAN CARTRIDGES" appears on the bottom line of the display.

3 Press **Enter** to start the cleaning process. Your product prints a cartridge cleaning page.

4 Examine the cleaning pattern. Compare the diagonal lines at the top and bottom of the test pattern.

A broken line shows any clogged nozzles. If the bottom line shows improvement, rerun this cleaning process two more times.

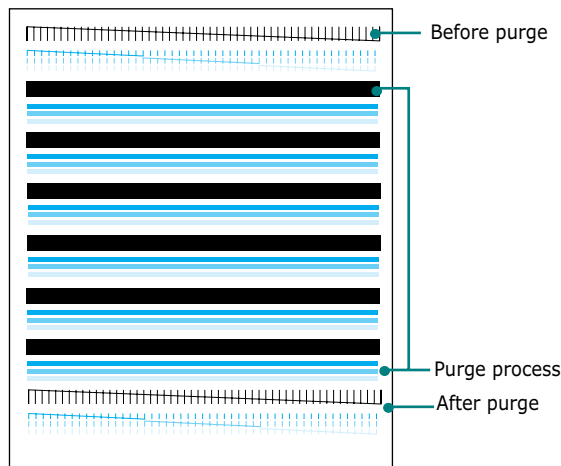

If this process does not improve the print quality, your print cartridges may be low in ink. Replace the print cartridge, if necessary.

5 If the line is still broken, clean the print nozzles. See "Cleaning the Print Cartridge Nozzles" on page 6.6.



Printing a Cleaning Page from Your Computer

- 1 Click **Start > Programs > Samsung SF-430 Series > Printer Control Program**.

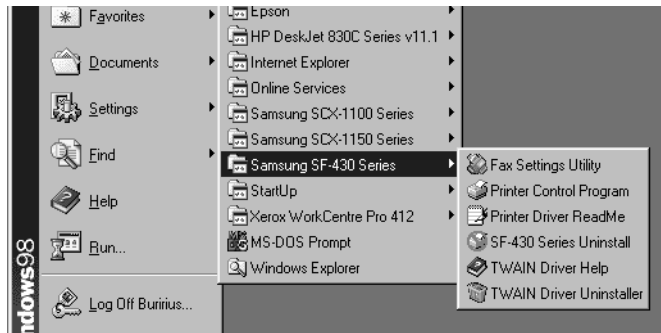

▲ In case of Windows 98

- 2 The Samsung SF-430 Series Control Program dialogue box appears. Select the **Cartridges** tab.

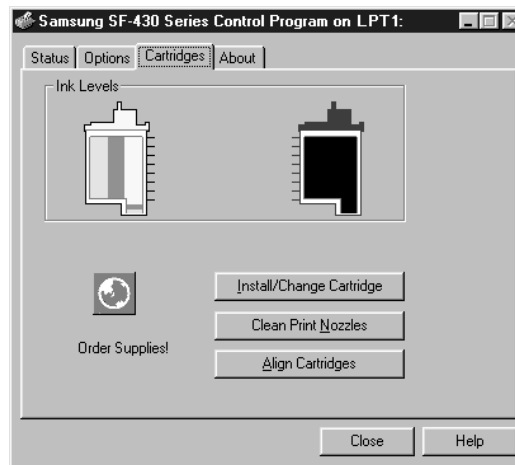

▲ In case of Windows 98



NOTE: In Windows 2000/XP, the Printer Control Program is unavailable. But, you can access the Cartridge Maintenance features through the printer properties by taking the following steps:

1. Click **Start > Settings > Printers**.
2. Right-click on the **Samsung SCX-1150 Series** printer in the Printers folder.
3. From the pop-up list, select **Properties**.
4. Click the **Cartridge Maintenance** tab.

- 3 Click **Clean Print Nozzles** from the Cartridges tab.
- 4 The product feeds a sheet of paper and prints a cleaning pattern. Examine the cleaning pattern. Refer to step 5 under "Printing a Cleaning Page from the SF-430" on page 6.4.

Cleaning the Print Cartridge Nozzles

If print quality does not improve after repeatedly printing the cleaning page, the problem may be caused by dried ink on the print cartridges.

- 1 Lift the front panel and open the top cover.

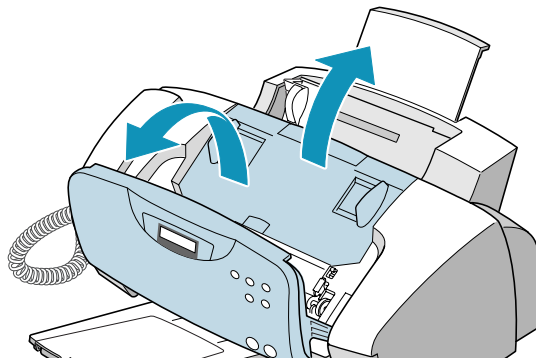

- 2 After the print cartridges have moved to the centre of the product, unplug the power cord from the back of your product.
- 3 Pull the print cartridge(s) towards you until you hear a click and remove the cartridge(s).

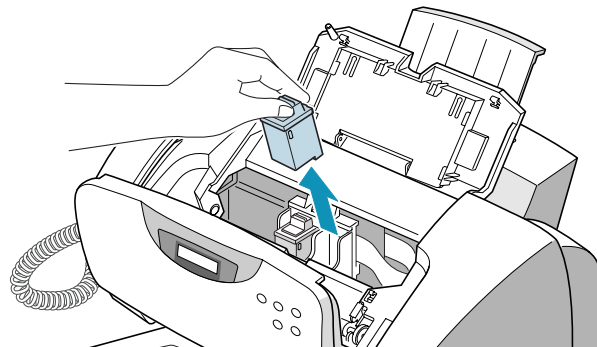

**NOTES:**

- Keep new and used print cartridges out of the reach of children.
- Be careful not to touch the ink nozzles or the electrical contacts. Touching these parts of the print cartridge can result in clogs, ink failure, or a bad electrical connection.

- 4** Use a clean cloth, dampened with water only, to gently clean the entire copper coloured area, including the nozzles and contacts.

To dissolve any dried ink, place the cartridge on a heavy damp cloth as shown below and push the cartridge with light pressure to let the nozzles come in contact with the cloth for about three seconds. Then gently blot and wipe dry.

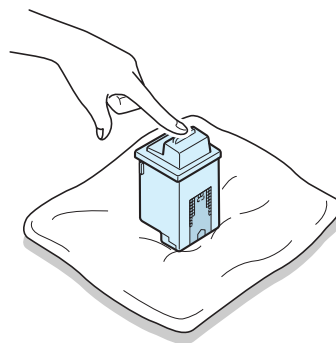

If you are cleaning a colour print cartridge, be especially careful to wipe the nozzles in only one direction so the colours do not mix.

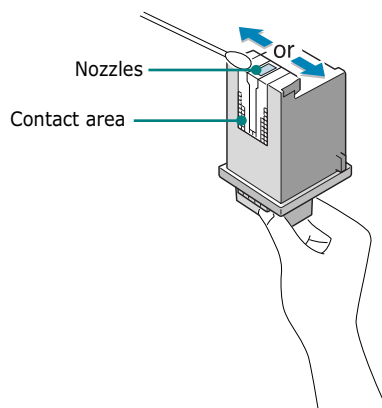

- 5 Allow the copper-coloured area to dry.
- 6 Reinstall the print cartridges and close the top cover. Then, plug the power cord in to turn the product on.

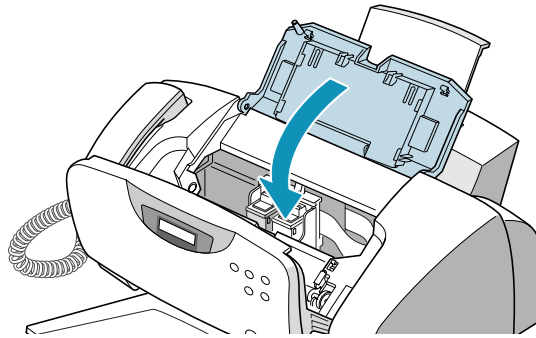

- 7 Print a cleaning page and examine the cleaning pattern. If the line is still broken, clean the print cartridge holder contacts in your product.



NOTE: Once the cartridges are removed and installed, cartridge alignment may be required. After you clean the cartridge, if necessary, align the cartridges.

Cleaning the Cartridge Holder Contacts

- 1** Open the front panel and the top cover. The print cartridges move to the centre of the printer.
- 2** Unplug the power cord from the electrical outlet or the rear of the product.
- 3** Remove the print cartridges.

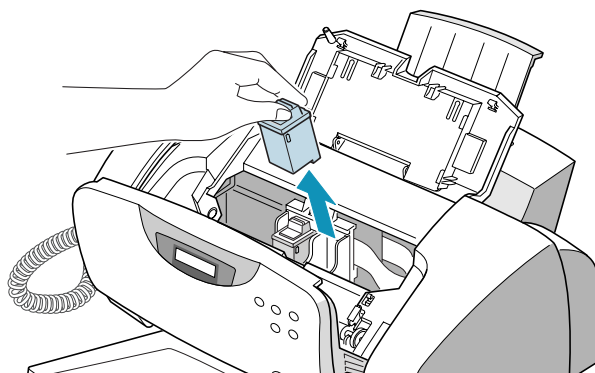

- 4** Use a CLEAN, DRY CLOTH to clean the print cartridge holder contacts inside the printer.

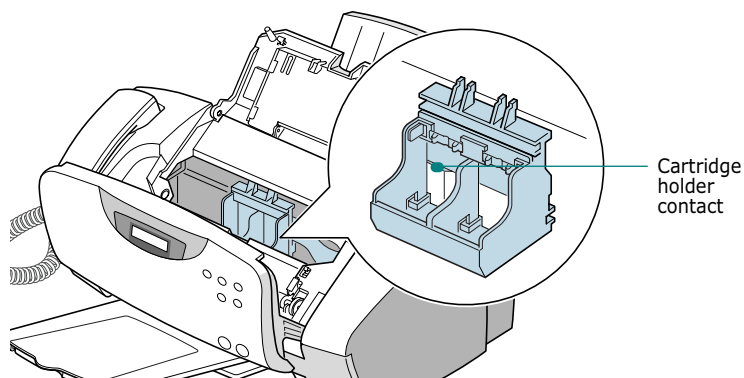

- 5** Install the print cartridges, and close the top cover and the front panel.

Then plug the power cord in.

Replacing the Print Cartridges

Your product is a dual cartridge inkjet printer. You must use a black (or photo) and a colour ink cartridge.

There are two types of black and colour cartridges: Standard and high yield. Before proceeding to install, you need to check which cartridge type you have. When you install the cartridges, you will be asked if it is Standard or High Yield. In order to find out the type, match the part number on the cartridge with the table below.

Cartridge type		Part number
Black cartridge	High yield	Lexmark 12A1975
	Standard	Samsung INK-M50 Lexmark 12A1970
Colour cartridge	High yield	Lexmark 15M0125
	Standard	Samsung INK-C60 Lexmark 15M0120
Photo cartridge		Lexmark 12A1990

When you notice the print becomes light or "CHANGE XXXXX INK" (where XXXXX designates the empty cartridge) appears in the display, replace the appropriate cartridge(s).

The print cartridge includes the ink supply and the print head. Each time you replace the ink cartridge you are replacing the print head as well.

Replacement of the print cartridges can be done from the front panel of your product or from the computer using the Samsung SF-430 Series Control Program.



Replacing Print Cartridges from the SF-430

- 1 Carefully unwrap the new ink cartridge(s) and remove the sealing tape by slowly pulling it in a straight out motion.

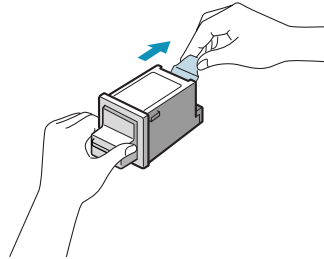

NOTE: Avoid touching the electrical contacts on the cartridge. Ensure that there are no pieces of tape remaining on the cartridge.

- 2 Lift the front panel by grabbing the panel along the top edge and pulling it towards you.

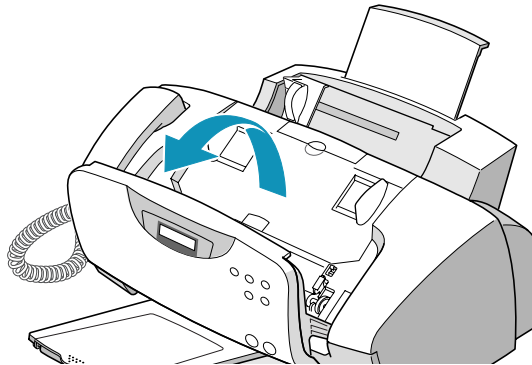

- 3 Open the top cover. The print cartridge holder moves to the centre position.

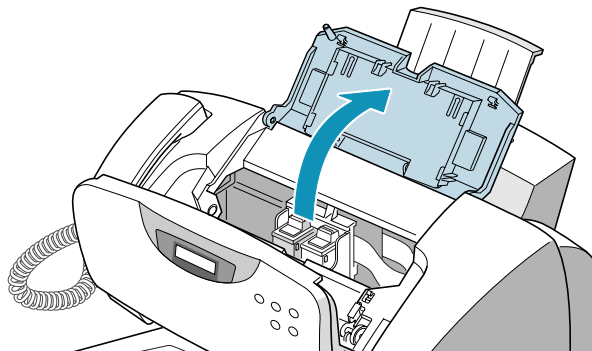

6

MAINTENANCE 6.11

- 4 Locate the print cartridge holder inside the product. The black (or photo) ink cartridge holder is located on the right and the colour ink cartridge is on the left.

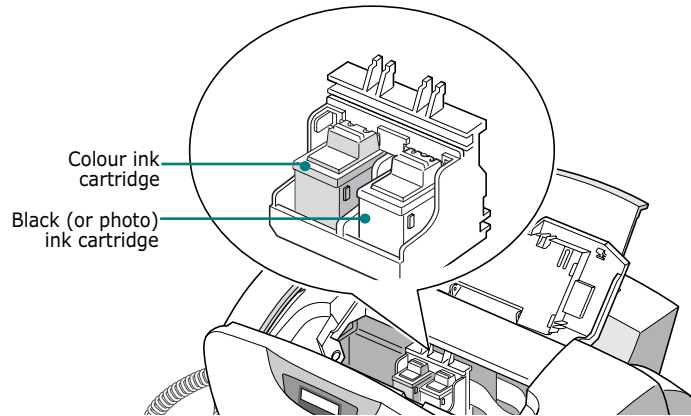

- 5 Pull the old cartridge(s) towards you until you hear a click and then remove the cartridge(s) from the holder.

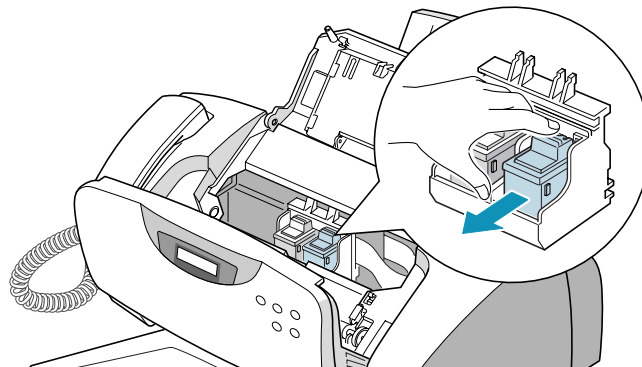

- 6 Place the new print cartridge(s) into the holder and push it forwards until it clicks into place.



NOTES: If the display shows "REMOVE PAPER JAM AND PRESS CANCEL" when you have closed the front panel, re-install the cartridge(s). With the print cartridge(s) installed improperly, the product might not print.

- 7 Close the top cover and then the front panel. The display prompts you to confirm the changed cartridge(s).

You can choose from LEFT, RIGHT or BOTH by using the **Scroll** buttons (◀ or ▶). Press **Enter** when your choice appears in the display.

- 8** The display prompts you to confirm a new or an old cartridge. Press the **Scroll** buttons (◀ or ▶) to scroll through the options and press **Enter** when your choice appears in the display.

The available options for the right cartridge are: NEW BLACK, OLD BLACK, NEW PHOTO, and OLD PHOTO. If you installed a photo cartridge instead of a black cartridge, select "NEW PHOTO" or "OLD PHOTO".

The available options for the left cartridge are: NEW COLOR and OLD COLOR.



NOTES:

- With the photo cartridge installed, only PC printing is available.
 - If you reinstall the printer driver or replace a print cartridge with an old cartridge, the ink level on the Printer Control Program may be incorrect even when you do not change the cartridges.
-

- 9** The display prompts you to confirm the cartridge capacity: Standard or High Yield. Use the **Scroll** buttons (◀ or ▶) to scroll through the options and press **Enter** when your choice appears in the display.

If you have installed a photo cartridge, you don't have to select the capacity of the photo cartridge because your product supports only a standard photo cartridge.



NOTE: If you make a mistake when you confirm the cartridge capacity, the ink level shown in the Printer Control Program may not be correct.

- 10** When you have finished setting the cartridge(s) and if any new cartridges were installed, the cartridge alignment procedure begins automatically by printing the Cartridge Alignment form.

Refer to step 4 under "Aligning the Print Cartridges" on page 6.16.

If you installed an old cartridge, the product returns to Standby mode without printing an Cartridge Alignment form.

CAUTION: Do not power off the product until the Cartridge Carrier Assembly has moved back into the home position. If no menu choices are made, the Carrier Assembly will automatically return to the home position after about one minute.



Replacing Print Cartridges from the Control Program

- 1** Click **Start > Programs > Samsung SF-430 Series > Printer Control Program**. You have accessed the Samsung SF-430 Series Control program.
- 2** Select the **Cartridges** tab.
- 3** Click **Install/Change Cartridge** from the Cartridge tab. The cartridge holder moves to the centre position.
- 4** Lift the front panel by grabbing the panel along the top edge and open the top cover. Replace the old cartridge(s) by following the instructions on page 6.11.

- 5 After installing, click the appropriate buttons in the Samsung SF-430 Series dialogue box to indicate the type of the cartridge(s) you have installed.

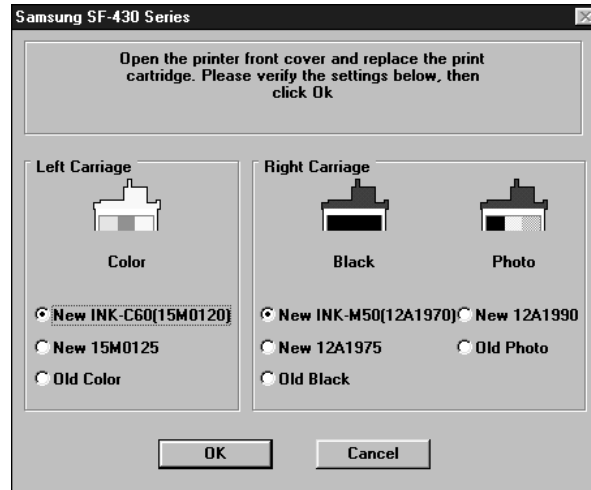

▲ In case of Windows 98

- 6 When you finish, click **OK**. If you have installed one or both cartridges as new, the message dialogue box appears to prompt you to align the cartridge. Click **Align**.
- 7 Your product prints the Cartridge Alignment form. Complete the alignment procedure by following the instructions on page 6.18.

If you installed an old cartridge(s), the product returns to Standby mode without printing the Cartridge Alignment form.

6



NOTE: In Windows 2000/XP, the Printer Control program is unavailable. But, you can access the Cartridge Maintenance features through the printer properties by taking the following steps:

1. Click **Start > Settings > Printers**.
2. Right-click on the **Samsung SF-430 Series** printer in the Printers folder.
3. From the pop-up list, select **Properties**.
4. Click the **Cartridge Maintenance** tab.

Aligning the Print Cartridges

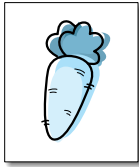

You must align the black and colour print cartridges after installing new print cartridges or if the black portions of graphics do not align with the colour portions.

Cartridge alignment can be done from the computer using the Samsung SF-430 Series Control Program or from the front panel of the product.

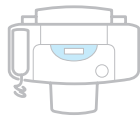

Aligning Print Cartridges from the SF-430

- 1 Press **Setup**. The display shows "1.SYSTEM SETUP" on the bottom line.
- 2 Press the **Scroll** buttons (◀ or ▶) until you find "8.MAINTENANCE" on the bottom line and then press **Enter**.
- 3 Press the **Scroll** buttons (◀ or ▶) until you see "ALIGN CARTRIDGE" on the display and then press **Enter** to start cartridge alignment.
- 4 The product feeds a sheet of paper and prints the Cartridge Alignment form.

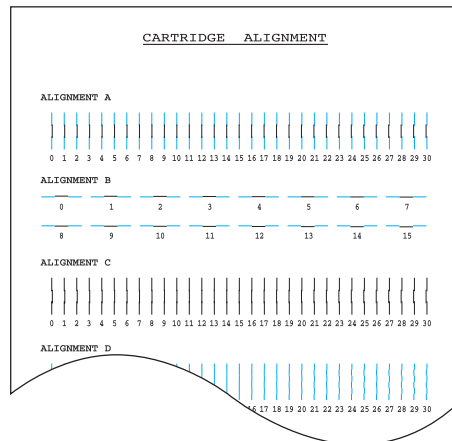

- 5 From each group on the form, locate the number under the alignment pattern that comes closest to forming a perfectly straight line.
- 6 The alignment entry menu appears on the display. The letter on the right end of the display corresponds to the alignment pattern. The range of numbers in the centre of the display indicates the range of valid selection choices. The flashing number on the left side of the display indicates the line from the form that is currently selected as optimal.

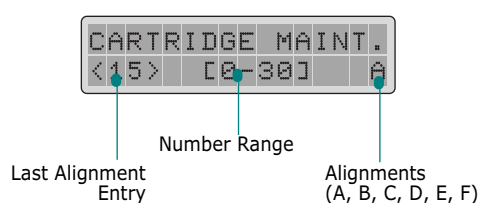

- 7 Enter the number of the line which appears the straightest from pattern A.

Press **Enter** to confirm your selection. The alignment entry menu for the Alignment B pattern is displayed.
- 8 Repeat step 7 for Alignment test patterns B through F (or D for the colour and the photo cartridges).
- 9 After you enter the number for the last group, Alignment F (or D for the colour and the photo cartridges), the display automatically returns to the Standby mode.

6



Aligning Print Cartridges from the Computer

- 1 Click **Start > Programs > Samsung SF-430 Series > Printer Control Program**. You have accessed the Samsung SF-430 Series Control program.
- 2 Select the **Cartridges** tab.
- 3 Click **Align Cartridges** from the Cartridge tab.

- 4 The product feeds a sheet of paper and prints the Cartridge Alignment form. The Align Cartridges dialogue box appears.

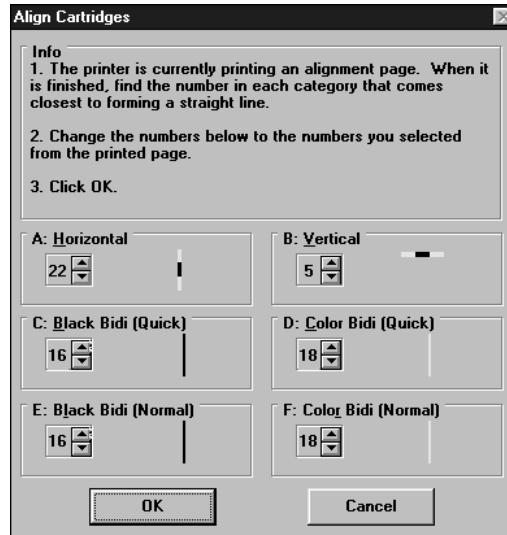

▲ In case of Windows 98

- 5 Locate the number under each alignment group in the pattern that comes closest to forming a perfect straight line and enter the number of the line or click repeatedly on the ▲ or ▼ button to select the number.
- 6 When the procedure is finished, click **OK**.



NOTE: In Windows 2000/XP, the Printer Control program is unavailable. But, you can access the Cartridge Maintenance features through the printer properties by taking the following steps:

1. Click **Start > Settings > Printers**.
 2. Right-click on the **Samsung SF-430 Series** printer in the Printers folder.
 3. From the pop-up list, select **Properties**.
 4. Click the **Cartridge Maintenance** tab..
-

Clearing Memory

You can selectively clear information stored in your product's memory.

- 1** Press **Setup**.
- 2** Press the **Scroll** buttons (◀ or ▶) until you see "7. MEMORY CLEAR" on the display and then press **Enter**.
- 3** Press the **Scroll** buttons (◀ or ▶) until you find the item you want to clear. You can also enter the number of the desired item.
 - **FAX NUMBER/NAME**: your fax number and name are cleared from memory.
 - **DIAL/SCHEDULE**: clears the phonebook numbers, one-touch, speed dial, or group dial numbers stored in the memory. Also, all Schedule Job operations reserved are cancelled.
 - **JOURNAL**: clears all records of transmissions and receptions.
 - **DEFAULT SETUP**: restores all settings to their factory defaults.
- 4** Press **Enter** when your choice appears in the display. The selected item is cleared.
- 5** Repeat steps 1 through 4 to clear another item.

Adjusting Shading

If the scanning unit becomes dirty, it can alter the shading value. If your print has black lines or is blurred, adjust the shading setting. Take the following steps:

- 1** Load a sheet of white Letter-size paper into the document feeder.
- 2** Press **Setup**.
- 3** Press the **Scroll** buttons (◀ or ▶) until you see "8.MAINTENANCE" on the display and then press **Enter**.
- 4** Press the **Scroll** buttons (◀ or ▶) until you see "ADJUST SHADING" on the display and then press **Enter**.



NOTE: Do not remove paper from the document feeder while adjusting.

Setting the Product to be Checked by Phone

The Remote Test feature allows your product to be checked out by a service company at a remote place by phone.

- 1** Press **Setup**.
- 2** Press the **Scroll** buttons (◀ or ▶) until you see "8.MAINTENANCE" on the display and then press **Enter**.
- 3** Press the **Scroll** buttons (◀ or ▶) until you see "REMOTE TEST" on the display and then press **Enter**.
- 4** Press the **Scroll** buttons (◀ or ▶) to turn this feature ON and then press **Enter**.

If you want to protect your product from being accessed by unauthorised persons, select "OFF".

Cleaning the Document Scanner

To keep your product working properly, occasionally clean the white roller, ADF rubber, and the scanning glass.



NOTE: Do not turn the power off to clean the scanner, as documents stored in the memory will be lost.

1 Lift the front panel by grabbing the panel along the top edge and pulling towards you.

2 Disassemble the white roller as follows:

Both ends of the white roller have plastic bushings that are snapped shut with small tabs on them. Pull the bushing on one end of the roller slightly inward (A), then rotate the bushing until it reaches a slot (B). Pull the roller upward.

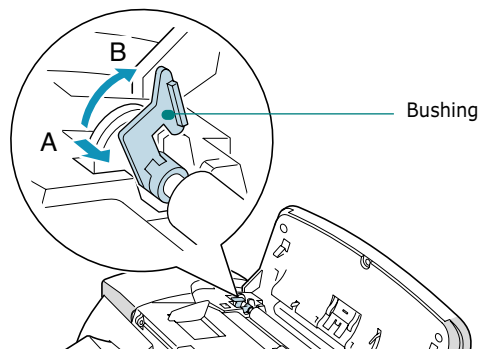

Remove the other end the same way.

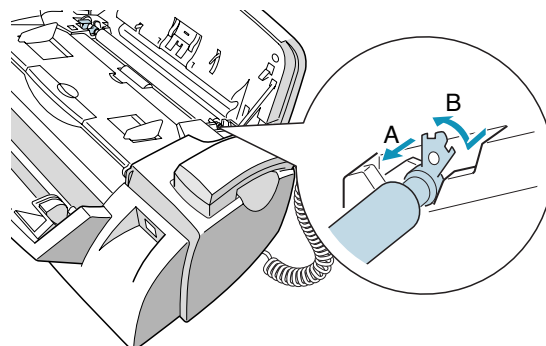

6

- 3** Wipe the roller surface with a soft cloth dampened with water.

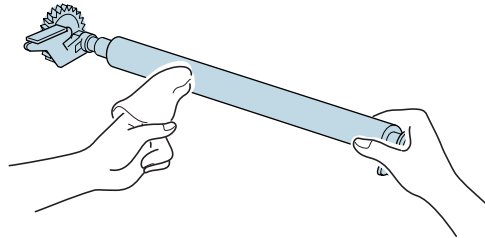

- 4** Clean the ADF rubber piece.

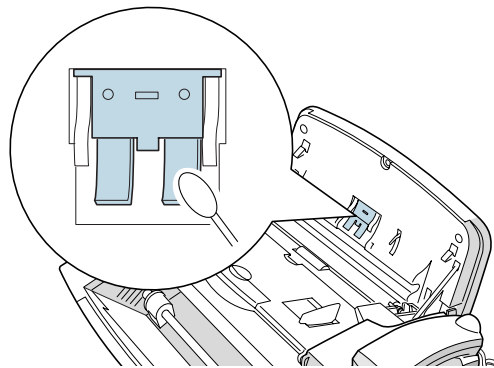

- 5** Carefully wipe the scanning glass with a soft, dry cloth.

If the glass is very dirty, first wipe it with a slightly dampened cloth, then with a dry cloth. Be very careful not to scratch the glass surface.

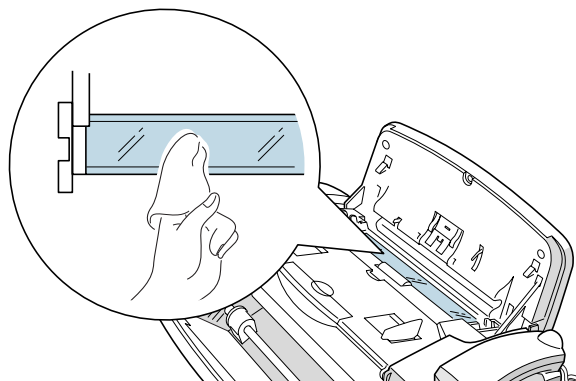

- 6** Replace the roller in reverse order, and then close the front panel firmly until it clicks into place.



7

TROUBLESHOOTING

This chapter gives helpful information for what to do if you encounter an error.

This chapter includes:

- **Clearing Jams**
- **LCD Error Messages**
- **Fixing Problems**

Clearing Jams

Document Jams While Sending a Fax

If a document jams while you are sending it, 'DOCUMENT JAM' appears in the display. Do not pull the document out of the slot. If you do this, it could harm your product.

- 1** Lift the front panel by grabbing the panel along the top edge and pulling towards you.

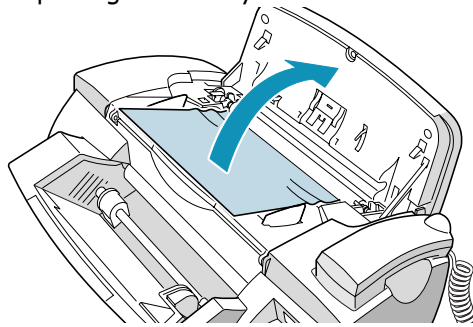

- 2** Carefully remove the jammed document.

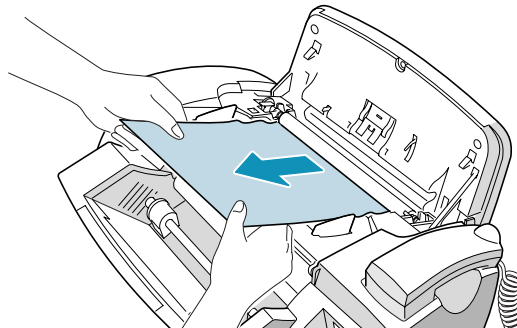

- 3** Close the front panel firmly until it clicks into place.

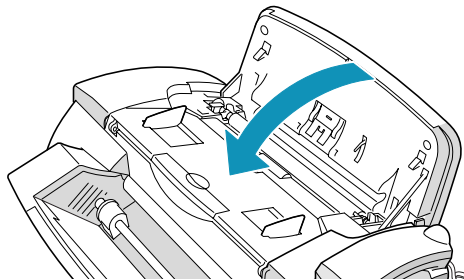

Paper Jams While the Product is Printing

If the paper jams while your product is printing, 'REMOVE PAPER JAM AND PRESS CANCEL ' appears in the display. Do not pull it out. If you do, it could harm the product

If Jammed in the received paper output area:

- 1 Remove the jammed paper by hand as shown.

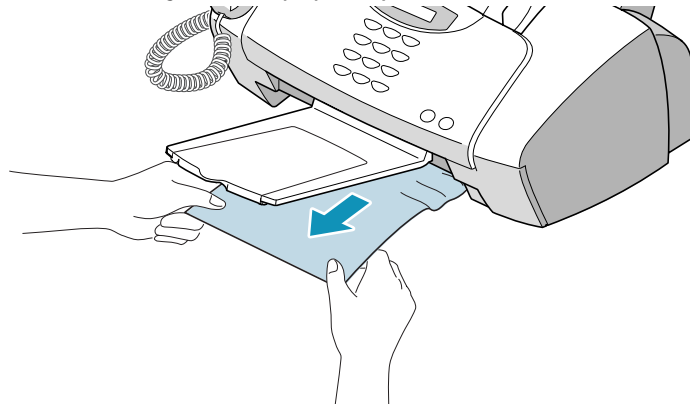

- 2 Press **Cancel/Reset** to clear the message.

If jammed in the paper feed area:

- 1 Remove the jammed paper as shown below.

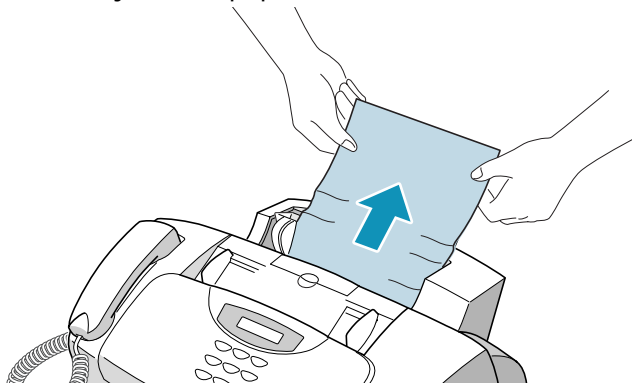

- 2 Press **Cancel/Reset** to clear the message.
- 3 After you have removed the jammed paper, load the paper with the print side facing you.

Squeeze the left paper guide and move it to the right to match the width of the paper.

If jammed inside the product:

- 1** Lift the front panel by grabbing the panel along the top edge and pulling towards you.

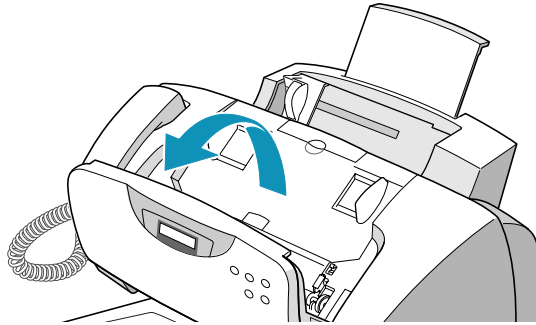

- 2** Open the top cover.

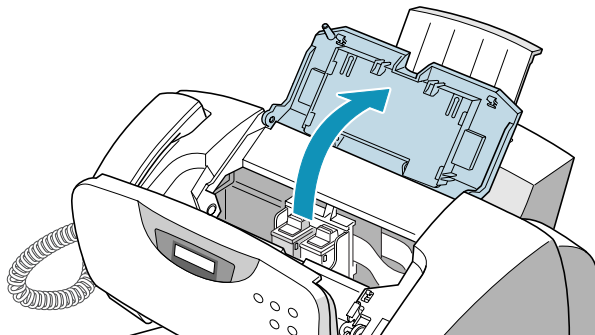

- 3** Carefully remove the jammed paper.

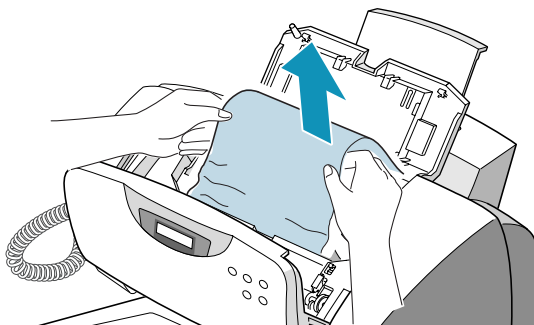

- 4** Close the cover and the front panel.

- 5** Press **Cancel/Reset** to clear the message.

Tips for Avoiding Paper Jams

By carefully selecting print materials and loading them properly, you should be able to avoid most paper jams. If jams do occur, follow the steps outlined in "Clearing Jams" on page 7.2. If jams occur frequently, make sure that you are following these preventative tips:

- Follow the procedures in "Loading Paper" on page 1.11 to load paper properly. Make sure that the adjustable guides are positioned correctly.
- Do not overload the paper. Up to 100 sheets can be loaded in the paper bin at a time.
- Envelopes with self-stick adhesives may cause wrinkling, creasing, or even jams and may even damage your product.
- Fan stacks of labels or transparencies before loading them into the paper bin. If jams occur, try feeding one sheet at a time.
- Do not load wrinkled, creased, damp, or highly curled paper.
- Do not mix paper sizes in the paper bin.
- Use only recommended print media.
- Make sure that the recommended print side is facing up when loading it in the paper bin.
- Keep print media stored in a suitable environment.

LCD Error Messages

Display	Meaning	Solution
ADD PAPER THEN PRESS ENTER	Paper has run out while printing.	Load paper in the paper bin and press Enter .
CHANGE BLACK INK	The black ink cartridge has run out.	Replace with a new ink cartridge.
CHANGE COLOR INK	The colour ink cartridge has run out.	Replace with a new ink cartridge.
CHANGE PHOTO INK	The photo ink cartridge has run out.	Replace with a new ink cartridge.
CHECK CARTRIDGES	The print cartridges are not installed or have some problem.	Check the print cartridges. Install or replace the cartridges if necessary.
CHECK LEFT CARTRIDGE	The colour cartridge is not installed or has some problem.	Check the colour cartridge. Install or replace if necessary.
CHECK RIGHT CARTRIDGE	The black (or photo) cartridge is not installed or has some problem.	Check the black (or photo) cartridge. Install or replace if necessary.
CID NUM. EMPTY	You have attempted to register a junk fax number when the CID list is empty.	The CID list is created when Caller Line Identification service is available. Make sure that you have subscribed to the service and there is a number in the CID list.
DOCUMENT JAM	The loaded document has jammed in the feeder.	Clear the document jam.
LINE ERROR	Your unit cannot connect with the remote machine, or has lost contact because of a problem on the phone line.	Try again. If failure persists, wait an hour or so for the line to clear, and try again. Or, turn the ECM mode on. See "Fax Setup Options" on page 5.38.

7.6 TROUBLESHOOTING

Display	Meaning	Solution
LOAD DOCUMENT	You have attempted to set up a sending operation with no document loaded.	Load a document and try again.
MEMORY FULL	The memory is full.	Either delete unnecessary documents, or retransmit after more memory becomes available, or split the transmission into more than one operation.
MEMORY JOB NOT ASSIGNED	You attempted to add documents when there is no scheduled job.	Check the display if there is any scheduled job. The display should indicate the job in Standby mode (for example, DELAY TX or SAVE TOLL).
NO ANSWER	The remote machine has not answered after all the redial attempts.	Try again. Make sure the remote machine is operational.
NO. NOT ASSIGNED	The one-touch or speed dial location you tried to use has no number assigned to it.	Dial the number manually with the keypad, or assign a number.
PC NOT AVAILABLE	Your product is not properly connected to your PC.	Check the cable connection between the product and the PC. Connect properly using a parallel or USB cable. See page 1.10.
POLLING ERROR	The remote fax machine you want to poll is not ready to respond to your poll. Or When setting up to poll another fax machine, you have used an incorrect poll code.	The remote operator should know in advance that you are polling and have their fax unit loaded with the original document. Or Enter the correct poll code.

Display	Meaning	Solution
RECEIVE ERROR	A fax has not been received successfully.	A problem with the facsimile communications has occurred. Ask the sender to try again.
REMOVE PAPER JAM AND PRESS CANCEL	Recording paper has jammed.	Clear the jam and press Cancel/Reset .
RETRY REDIAL?	The product is waiting for a specified time interval to redial a station which was busy or did not answer previously.	You can press Enter to immediately redial, or Cancel/Reset to cancel the redial operation.
SEND ERROR	Your fax has not gone through successfully.	A problem with the facsimile communications has occurred. Try again.
TX NOT AVAILABLE	You have attempted to send a document while the product is printing received data.	Send the document after the current job is completed.
WRONG PIN CODE	You have entered the wrong PIN Code.	Re-enter the correct four digits of the PIN code.

7.8 TROUBLESHOOTING

Fixing Problems

Fax Problems

Symptom	Cause and Solution
The product is not working, there is no display and the buttons are not working.	<ul style="list-style-type: none">• Unplug the power cord and plug it in again.• Check that your socket is active.
No dial tone.	<ul style="list-style-type: none">• Check that the phone line is connected properly.• Check the phone socket on the wall by plugging in another phone.
The numbers stored in the memory do not dial correctly.	<ul style="list-style-type: none">• Make sure that the numbers are stored in the memory correctly.• Print a Phonebook list. See page 5.36.
The document does not feed into the product.	<ul style="list-style-type: none">• Make sure that the document is not wrinkled and you are putting it in correctly. Check the document is the right size, not too thick or thin.• Make sure that the cover is firmly closed.
You cannot receive faxes automatically.	<ul style="list-style-type: none">• The FAX mode should be selected.• Is there paper in the product?• Check if the display shows "MEMORY FULL".
Your product cannot receive faxes manually.	<ul style="list-style-type: none">• Did you hang up the handset before you pressed Start FAX Black or Start FAX Color?
Your product will not send anything.	<ul style="list-style-type: none">• Make sure that the document is loaded face down.• "TX" should show up on the display.• Check the other fax machine you are sending to, to see if it can receive your fax.
You cannot poll another fax machine.	<ul style="list-style-type: none">• The product you are polling may be using a poll code.

Symptom	Cause and Solution
The incoming fax has blank spaces or you received a poor-quality copy.	<ul style="list-style-type: none"> • The product sending you the fax may be faulty. • The remote fax machine sending you a fax may have a dirty scan glass. • A noisy phone line can cause line errors. • Check your product by making a copy. • The print cartridge may be empty.
Are some of the words on the incoming fax stretched?	<ul style="list-style-type: none"> • The fax machine sending you the fax had a temporary document jam.
There are lines on the copies or documents you send.	<ul style="list-style-type: none"> • Check your scan glass for marks, and clean it. See page 6.21.
The product dials a number, but fails to make a connection with another fax machine.	<ul style="list-style-type: none"> • The other fax machine may be turned off, out of paper, or cannot answer incoming calls. Speak with the other machine operator and ask them to sort out the problem.
You cannot store a document in the memory.	<ul style="list-style-type: none"> • There may not be enough memory to store the document. If the display shows a 'MEMORY FULL' message, delete any documents you no longer need from the memory, and restore the document.
Blank areas appear at the bottom of each page or on other pages, with only a small strip of text printed at the top.	<ul style="list-style-type: none"> • You may have chosen the wrong paper settings in the user option setting. See page 5.39 to choose a proper paper size.

7.10 TROUBLESHOOTING

Paper Feeding Problems

Symptom	Cause and Solution
Paper is jammed during printing.	Clear the paper jam. See page 7.2.
Paper sticks together.	<ul style="list-style-type: none"> • Ensure there is not too much paper in the paper bin. Depending on the thickness of your paper, the paper bin can hold up to 100 sheets of paper. • Make sure you are using the correct type of paper. See "Paper Selection" on page 2.2. • Remove paper from the paper bin and flex or fan the paper. • Humid conditions may cause some paper to stick together.
Paper fails to feed.	Remove any obstructions inside the product.
Multiple sheets of paper do not feed.	<ul style="list-style-type: none"> • Different types of paper may be stacked in the paper bin. Load the paper of only one type, size, and weight. • When loading paper, do not force the paper down into the printer. • If multiple sheets have caused a paper jam, clear the paper jam. See page 7.2.
Paper skews or buckles	<ul style="list-style-type: none"> • Ensure there is not too much paper in the paper bin. Depending on the thickness of your paper, the paper bin can hold up to 100 sheets of paper. • Make sure the paper guide does not cause the paper to bow in the paper bin. • Make sure you are using the correct type of paper. See "Paper Selection" on page 2.2. • When loading paper, do not force the paper down into the product. • Make sure the right side of the paper is aligned with the right edge of the paper bin, and the left paper guide is set against the left side of the paper.
Transparencies stick together in the paper exit.	Use only the transparencies specially designed for an ink jet printer. Remove each transparency as it exits from the printer.

Symptom	Cause and Solution
Envelopes skew or fail to feed correctly.	Ensure that the paper guide is against the left side of the envelopes.

General Printing Problems

Problem	Possible Cause and Remedy
Your product does not print.	<ul style="list-style-type: none"> • The printer cable is not connected properly. Check the printer cable connection. • The printer cable is defective. Swap the cable with one known to work. • The port setting is incorrect. Check the Windows printer settings to make sure that the print job is being sent to the correct port (for example, LPT1). • You have unplugged the USB cable from your computer then plugged back to a different USB port than you have used before. In this case, your printer driver creates a virtual printer in the Printer folder on your computer system each time you use another different port. You have to remove the newly created virtual printer(s). To remove: <ol style="list-style-type: none"> 1. Open the Printer folder and right-click on the last created Samsung SF-430 Series Copy x (where x is the number of the created virtual printers). 2. Select Properties from the pop-up menu and then click Ports tab. 3. Locate the USB port which is checked and then close the Printer folder. 4. Reopen the Printer folder. 5. Right-click on the original printer Samsung SF-430 Series. 6. Select Properties from the pop-up menu and then click Ports tab. 7. Put a check mark in the checkbox of the USB port you have found at step 3. 8. Remove Samsung SF-430 Series Copy x from the Printer folder.

Problem	Possible Cause and Remedy
Your product does not print. (continued)	<ul style="list-style-type: none"> • The print cartridge is not installed properly. Remove and reinsert the print cartridge. • The printer properties may be configured incorrectly. Check the application to make sure that all print settings are correct. • The printer driver may be incorrectly installed. Uninstall the MFP driver and reinstall the MFP driver. Then try printing a test page. Refer to "Uninstalling Samsung Software" on page See "Uninstalling Samsung Software" on page 1.29. • A paper jam has occurred. Remove the jammed paper. See page 7.2. • For Windows 2000/XP, if you remove the product from the PC and then connect back to the PC, the printer might be set to Off line status. Open the Windows Printer folder and check if the SF-430 is off line. If so, right-click on SF-430 Series printer and deselect Use Printer Offline.
A file sent from Acrobat Reader 4.0 does not print or print properly.	<ul style="list-style-type: none"> • From the Acrobat Reader File menu, Select Print and check the Print as image box. If it does not solve the problem, upgrade Acrobat Reader to 5.0 or higher.
The paper is not fed into the product.	<ul style="list-style-type: none"> • Paper has not been inserted correctly. Remove and reinsert the paper correctly. See "Loading Paper" on page 1.11. • There is too much paper in the paper bin. Remove some of the paper from the paper bin.
The paper keeps jamming.	<ul style="list-style-type: none"> • There is too many sheets of paper in the paper bin. Remove some of the paper from the bin. (If printing onto transparencies, or labels, insert them one at a time.) • The paper setting method may be incorrect. If printing onto envelopes, insert the envelopes to have a gap of approximately 1 mm (1/32") between the left and right edge of the envelopes at the paper guide.

Problem	Possible Cause and Remedy
Part of the printed page is blank.	<ul style="list-style-type: none"> • The page layout is too complex. Simplify the page layout and remove any unnecessary graphics from the document if possible. • The page orientation setting may be incorrect. Change the page orientation in the Printer Properties dialogue box. • The paper size and the software paper size settings do not match. Insert the correct paper into the product or change the software paper size settings. • If using a parallel cable, ensure that it is compliant with an IEEE-1284 rated cable.
Your product prints the wrong data, or it prints incorrect characters.	<ul style="list-style-type: none"> • The printer cable might not be connected properly. Check the printer cable connection. • There may be a problem with the printer driver software. Exit Windows and reboot the computer. Turn the printer off and then back on again. • If using a parallel cable, ensure that it is compliant with an IEEE-1284 rated cable.
Printing is too slow.	<ul style="list-style-type: none"> • You may be using High or Maximum print quality. See page 2.11. The higher the quality, the lower the speed. • If you are using Windows NT, the Scheduling setting may be set incorrectly. From the Start menu, select Settings and Printers. Click your printer icon with the right mouse button, select Properties, click the Scheduling tab. Then, select the desired scheduling setting from the available choices.
When printing using the USB connection, an error occurs repeatedly	<p>When the USB mode is set to FAST, the communication between the product and the computer may be poor. Change the USB mode to SLOW. To do so, take the following steps:</p> <ol style="list-style-type: none"> 1. Press Setup on the front panel. You can see "1.SYSTEM SETUP" on the display. 2. Press Enter. 3. Press the Scroll buttons (◀ or ▶) until you see "USB MODE" and then press Enter. 4. Press the Scroll buttons (◀ or ▶) to select "SLOW" and then press Enter to save the selection.

7.14 TROUBLESHOOTING

Colour Printing Problems

Problem	Possible Cause and Remedy
Your product prints only in black	<ul style="list-style-type: none"> • The Samsung SF-430 Series printer driver may not be selected. Verify that you selected the Samsung SF-430 Series printer driver. • The colour print cartridge may not be working properly. Print a test page to make sure the ink cartridges are working correctly. • The print nozzles of the colour print cartridge may need to be cleaned. Clean the print cartridges. See page 6.3. • You may be using Black Only in your printer driver. See page 2.11.
Colours print incorrectly	<ul style="list-style-type: none"> • The Samsung SF-430 Series printer driver may not be selected. Verify that you selected the Samsung SF-430 Series printer driver. • Print cartridges may be installed in the incorrect holders. Remove each print cartridge that is in an incorrect holder. Check that the ink have not mixed in the cartridges. If this is the case, replace the cartridge with a new one. • Print a test page. If the problem persists, replace the cartridge with new one. • Print nozzles on the colour print head may be clogged. Print a test page to check the status of the nozzles and clean the print cartridge. See page 6.3.
Colours are missing	<ul style="list-style-type: none"> • The colour print cartridge may not be working properly. Print a test page to make sure the ink cartridge is working correctly. • The print head may need to be cleaned. Clean the print cartridges. See page 6.3.
Colours in a line are uneven, or different from the previous lines	<ul style="list-style-type: none"> • You may have turned the product off(paused) and then on(resumed) during print job. Do not turn the product off and back on during a print job. • Set the print quality to High or Maximum in the printer driver. • Align the print cartridges. See page 6.16.

Problem	Possible Cause and Remedy
Hue changes	<ul style="list-style-type: none"> • Print nozzles on the print head may be clogged. Print a test page to check the status of the nozzles and clean the print cartridge. See page 6.3. • The colour print cartridge may be empty. Replace the cartridge with a new one. See page 6.10.

Print Quality Problems

Problem	Possible Cause and Remedy
Light print or fade	<ul style="list-style-type: none"> • The print cartridge may be running out of ink. Install a new ink cartridge. • The paper may not meet paper specifications (for example, the paper is too moist or too rough). See "Paper Selection" on page 2.2. • If the whole page is light, the print resolution setting is too low. Adjust the print resolution within the printer properties. See page 2.11. • A combination of faded and smeared defects may indicate that the print cartridges need to be cleaned. See "Cleaning the Print Cartridges" on page 6.3.
Splashed dots	<ul style="list-style-type: none"> • The paper may not meet paper specifications (for example, the paper is too moist or too rough). See "Paper Selection" on page 2.2. • The print nozzles may be clogged with ink. See "Cleaning the Print Cartridges" on page 6.3.
White streaks or missing dots	<ul style="list-style-type: none"> • The moisture content of the paper is uneven or the paper has moist spots on its surface. Try a different kind or brand of paper. • Print cartridges may be installed incorrectly. Make sure the print cartridges are installed correctly. • A print cartridge may be empty. Check the contacts of the print cartridge. If there is not any ink in the cartridge, replace it with a new one. • The print media being used may not be acceptable. Use only print media specified in "Paper Selection" on page 2.2. • The print head may be aligned incorrectly. Print the alignment pattern to align the print cartridge. See page 6.16.

7.16 TROUBLESHOOTING

Problem	Possible Cause and Remedy
Blurred or smudged ink	<ul style="list-style-type: none"> • You may printing on the wrong side of the paper. Turn the paper over and print on the other side. • The paper may not meet paper specifications (for example, too moist or too rough). See "Paper Selection" on page 2.2. • Let the ink dry before handling the paper.
Characters with white lines	<ul style="list-style-type: none"> • The print cartridge may be almost empty. Check the contacts of the print cartridge and replace, if necessary. • The print cartridges may need to be cleaned. See "Cleaning the Print Cartridges" on page 6.3.
Characters are improperly formed or not aligned correctly	<ul style="list-style-type: none"> • The print media is loaded incorrectly or is an unsupported size or type. Use the print media specified in "Paper Selection" on page 2.2. • If characters are improperly formed, producing a wavy effect, the scanner unit may need servicing. • The print cartridges may need to be cleaned. See "Cleaning the Print Cartridges" on page 6.3. • The print cartridges may need to be aligned. See "Aligning the Print Cartridges" on page 6.16.
Vertical lines in tables, borders and graphics not smooth	<ul style="list-style-type: none"> • The print cartridge may need to be cleaned. See "Cleaning the Print Cartridges" on page 6.3. • The print cartridge may need to be aligned. See "Aligning the Print Cartridges" on page 6.16.
Solid black areas contain white streaks	<ul style="list-style-type: none"> • Change the fill pattern in the application software.
Printing appears jagged	<ul style="list-style-type: none"> • The print resolution selected in the printer driver may be low. Check the printer driver for the correct resolution. Printing in low resolution will give the printout a jagged look. Change the Print Quality to a higher resolution. See page 2.11.

Scanning Problems

Problem	Possible Cause and Remedy
<p>The product does not scan.</p>	<ul style="list-style-type: none"> • Make sure you place the document to be scanned face down on the document glass. • There may not be enough available memory to hold the document you want to scan. Try the Pre-Scan function to see if that works. Try lowering the scan resolution rate. • The USB or parallel cable is not connected properly. • The USB or parallel cable is defective. Swap the cable with a known good cable. If necessary, replace the cable. • If using a parallel cable, ensure that it is compliant with the IEEE 1284 standard. • The scanner is configured incorrectly. Check scan setting in the SmarThru Configuration or the application you want to use to make certain that the scanner job is being sent to the correct port (for example, LPT1).
<p>The unit scans very slowly.</p>	<ul style="list-style-type: none"> • Check if the product is printing received data. Scan the document after the current job is completed. • Graphics are scanned more slowly than text. • Communication speed becomes slow in scan mode because of the large amount of memory required to analyse and reproduce the scanned image. Set your computer to ECP printer mode through BIOS setting. It will help to increase the speed. For details on how to set BIOS, refer to your PC documentation.
<p>The following message appears on the computer screen: Scanner is busy receiving or printing data. When the current job is completed, try again.</p>	<p>There may be a copying or printing job in progress. When the current job is completed, try the job again.</p>

8

APPENDIX

This chapter includes:

- **Printer Specification**
- **Scanner and Copier Specification**
- **Fax Specification**
- **General Specification**
- **Paper Specification**

Printer Specification

Item	Description
Emulation	HBP (GDI)
Resolution	True 600 x 600 dpi, 2400 x 1200 dpi
Printing speed	14 PPM (mono) 7 PPM (colour)
Effective printing width	203 ± 1 mm (8 inches)

Scanner and Copier Specification

Item	Description
Scanning method	CIS, Sheetfeed
Scan resolution	600 x 1200 dpi
Scan mode	True colour, 256 grey, Black and white
Copy mode	Colour, Black and white
Effective scanning width	210 mm
Maximum document width	216 mm
Multi copy range	1 ~ 99
Reduction & Enlargement	25% ~ 400% in 1% increment
Maximum print edge margin	Top: max 4mm Bottom: max 5 mm * Print Quality Guarantee margin Colour: 19.05 mm mono: 12.7 mm Each side: 3.5 mm ± 2 mm (A4) 6.5 mm ± 2 mm (LTR)

Fax Specification

Item	Description
Applicable line	G3 PSTN (Public Switched Telephone Network)
Compatibility	ITU Group 3
Resolution	Mono Standard: 203 x 98 dpi Fine: 203 x 196 dpi Super Fine: 300 x 300 dpi
	Colour 200 x 200 dpi (High compression) 200 x 200 dpi (Middle compression) 200 x 200 dpi (Low compression)
Data coding	MH/MR/MMR/JPEG
Maximum modem speed	33.6 kbps
Transmission speed	3 sec. (Standard resolution, MMR, 33.6 kbps)
Memory	2 Mbytes
Effective scanning width	210 mm
Effective printing width	203 mm ± 1 mm (8 inches)
Document width and weight	176 ~ 216 mm, 16 lb ~ 24 lb
ADF capacity	30 pages (20 lb)

General Specification

Item	Description
Paper bin capacity	100 sheets (20 lb)
Paper output tray capacity	50 sheets (20 lb)
Printer/Scanner average life time (approximate)	20,000 pages
ADF Rubber life time (approximate)	10,000 pages
Operating Environment	Temperature: 10-32 °C (20 ~ 80% RH)
Original document width and weight	176 ~ 216 mm, 16 lb ~ 24 lb
Power rating	See Rating Label attached on the back of the machine.
Power consumption	15 W in Standby mode 20 W during operation
Weight	5.6 kg (without cartridges)
Dimensions (WxDxH)	With the paper support and output tray retracted: 439.8 x 326.6 x 192.9 mm With the paper support and output tray extended: 439.8 x 602.5 x 192.9 mm
Ink Cartridge Life (approximate)	Black Cartridge High yield: 1,100 sheets Standard: 600 sheets (based on ITU 5% chart - see "A Sample of ITU 5% Chart (reduced to 60%)" on page 8.6.)
	Colour Cartridge High yield: 625 sheets Standard: 275 sheets (based on ITU 15% chart)
	Photo Cartridge: 450 sheets (based on ITU 15% chart)

Paper Specification

Item	Description		
Paper types available	Plain paper, OHP film, Label, Envelope, Card, Postcard		
Paper sizes	Paper Type	W x L (mm)	W x L (Inch)
	Letter	215.9 x 279	8.5 x 11
	Legal	215.9 x 355.6	8.5 X 14
	JIS B5	182 x 257	7.17 x 10.12
	A4	210x 297	8.27 x 11.69
	Executive	184.2 x 266.7	7.25 x 10.5
	A5	148.5 x 210	5.85 x 8.27
	A6 card	105 x 148.5	4.13 x 5.85
	Post Card 4x6	101.6 x 152.4	4 x 6
	HagaKi	100 x 148	3.94 x 5.83
	Envelope 7-3/4	98.4 x 190.5	3.88 x 7.5
	Envelope COM-10	105 x 241	4.12 x 9.5
	Envelope DL	110 x 220	4.33 x 8.66
	Envelope C5	162 x 229	6.38 x 9.02
	Custom	76 ~ 216 x 127 ~ 432	2.99 ~ 8.5 x 5 ~ 17

A Sample of ITU 5% Chart (reduced to 60%)

THE SLEREXE COMPANY LIMITED
SAPORS LANE - BOOLE - DORSET - BH 25 8 ER
TELEPHONE BOOLE (945 13) 51617 - TELEX 123456

Our Ref. 350/PJC/EAC 18th January, 1972.

Dr. P.N. Cundall,
Mining Surveys Ltd.,
Holroyd Road,
Reading,
Berks.

Dear Pete,

Permit me to introduce you to the facility of facsimile transmission.

In facsimile a photocell is caused to perform a raster scan over the subject copy. The variations of print density on the document cause the photocell to generate an analogous electrical video signal. This signal is used to modulate a carrier, which is transmitted to a remote destination over a radio or cable communications link.

At the remote terminal, demodulation reconstructs the video signal, which is used to modulate the density of print produced by a printing device. This device is scanning in a raster scan synchronised with that at the transmitting terminal. As a result, a facsimile copy of the subject document is produced.

Probably you have uses for this facility in your organisation.

Yours sincerely,

Phil.

P.J. CROSS
Group Leader - Facsimile Research

Registered in England: No. 2098
Registered Office: 80 Vicars Lane, Ilford, Essex.

Replacing the Fitted Plug (UK)

Important

The mains lead for this machine is fitted with a standard (BS 1363) 13 amp plug and has a 13 amp fuse. When you change or examine the fuse, you must re-fit the correct 13 amp fuse. You then need to replace the fuse cover. If you have lost the fuse cover, do not use the plug until you have another fuse cover. Please contact the people from you purchased the machine.

The 13 amp plug is the most widely used type in the UK and should be suitable. However, some buildings (mainly old ones) do not have normal 13 amp plug sockets. You need to buy a suitable plug adaptor. Do not remove the moulded plug.

Warning

If you cut off the moulded plug, get rid of it straight away.
You cannot rewire the plug and you may receive an electric shock if you plug it into a socket.

Important warning: You must earth this machine

The wires in the mains lead have the following colour code:

- Green and Yellow: Earth
- Blue: Neutral
- Brown: Live

If the wires in the mains lead do not match the colours marked in your plug, do the following:

You must connect the green and yellow wire to the pin marked by the letter 'E', or by the safety 'Earth symbol' or coloured green and yellow or green.

You must connect the blue wire to the pin which is marked with the letter 'N' or coloured black.

You must connect the brown wire to the pin which is marked with the letter 'L' or coloured red.

You must have a 13 amp fuse in the plug, adaptor, or at the distribution board.

Notes For Use of This Device (New Zealand)

The grant of a Telepermit for any item of terminal equipment indicates only that Telecom has accepted that the item complies with minimum conditions for connection to its network. It indicates no endorsement of the product by Telecom, nor does it provide any sort of warranty. Above all, it provides no assurance that any item will work correctly in all respects with another item of Telepermitted equipment of a different make or model, nor does it imply that any product is compatible with all of Telecom's network services.

This equipment shall not be set up to make automatic calls to the Telecom '111' Emergency Service.

This equipment may not provide for the effective hand-over of a call to another device connected to the same line.

Important Notice

Under power failure conditions, this telephone may not operate. Please ensure that a separate telephone, not dependent on local power, is available for emergency use.

Declaration of Conformity (European Countries)

Approvals and Certifications



The CE marking applied to this product symbolises Samsung Electronics Co., Ltd. Declaration of Conformity with the following applicable 93/68/EEC Directives of the European Union as of the dates indicated:

January 1, 1995: Council Directive 73/23/EEC Approximation of the laws of the member states related to low voltage equipment.

January 1, 1996: Council Directive 89/336/EEC (92/31/EEC), approximation of the laws of the Member States related to electromagnetic compatibility.

March 9, 1999: Council Directive 1999/5/EC on radio equipment and telecommunications terminal equipment and the mutual recognition of their conformity.

A full declaration, defining the relevant Directives and referenced standards can be obtained from your Samsung Electronics Co., Ltd. representative.

EC Certification

Certification to 1999/5/EC Radio Equipment & Telecommunications Terminal Equipment Directive (FAX)

This Samsung product has been self-certified by Samsung for pan-European single terminal connection to the analogue public switched telephone network (PSTN) in accordance with Directive 1999/5/EC. The product has been designed to work with the national PSTNs and compatible PBXs of the European countries:

In the event of problems, you should contact the Euro QA Lab of Samsung Electronics Co., Ltd. in the first instance.

The product has been tested against TBR21 and/or TBR 38. To assist in the use and application of terminal equipment which complies with this standard, the European Telecommunication Standards Institute (ETSI) has issued an advisory document (EG 201 121) which contains notes and additional requirements to ensure network compatibility of TBR21 terminals. The product has been designed against, and is fully compliant with, all of the relevant advisory notes contained in this document.

Memo



INDEX

A

- Add documents..... 5.34
- Align, print cartridge 6.16
 - from SF-430 6.16
 - from the computer 6.17
- Automatic dial
 - group 5.25
 - one-touch 5.22
 - speed 5.23

B

- Booklet, print 2.12
- Broadcasting 5.28

C

- Cancel
 - fax 5.8
 - print..... 2.7
 - scan 4.5
 - scheduled fax 5.35
- Character, enter 1.38
- Clean
 - cartridge holder contact 6.9
 - document scanner..... 6.21
 - print cartridge 6.3
 - print nozzle 6.6
- Clean, print cartridge 6.3
 - from SF-430 6.4
 - from the computer 6.5
- Clearing..... 7.2
- Clock mode, change 1.36
- Collate
 - copy 3.8
 - print..... 2.10
- Contents..... 1.3
- Contrast
 - copy 3.6
 - fax 5.4
 - print..... 2.14
- Control program 2.18
- Copy page

- for copy 3.7
- for print 2.10
- Copying a document 3.4

D

- Date and time, set 1.34
- Date format, change 1.36
- Default setting
 - copy 3.9
 - fax 5.5
- Delayed fax..... 5.29
- Dialling mode, set..... 1.42
- Discard size, set 1.40
- Document
 - set for copy 3.5
 - set for fax 5.3
 - set for print..... 2.11
- Document jam, clear 7.2
- DRPD mode
 - receiving faxes 5.19
 - set up..... 5.41

E

- Error messages 7.6

F

- Fax and Internet gate..... 1.25
- Fax number and name, set..... 1.37
- Fax Settings Utility..... 5.44
- Fax setup options 5.38
 - from the computer 5.45
- Faxing a document
 - receive 5.14
 - send..... 5.2
- Forwarding fax 5.20
- Front panel
 - buttons..... 1.6
 - location 1.4

G			
Guide			
document.....	3.4, 5.6		
paper	1.12		
H			
Handout, print.....	2.13		
I			
Ink level, view			
from control program.....	2.19		
from SF-430	6.3		
Ink save mode	1.45		
J			
Jams, clear			
document.....	7.2		
paper	7.3		
K			
Key sound, set	1.41		
L			
Language, change.....	1.40		
LCD			
error messages.....	7.6		
location and function	1.6		
Load			
document.....	3.4, 5.6		
paper	1.11		
M			
Memory, clear	6.19		
O			
Orientation, print.....	2.10		
P			
Paper guidelines	2.5		
Paper jams, clear.....	7.3		
Paper save mode	1.45		
Paper size			
set for copy	3.2		
set for fax	5.39		
set for PC print	2.10		
Paper type			
set for copy	3.3		
set for PC print	2.10		
Paper, load	1.11		
Paper, select	2.2		
PIN code, set	1.43		
Polling.....	5.32		
Poster			
print.....	2.13		
Print cartridge			
align.....	6.16		
clean	6.3		
install	1.13		
maintain	6.2		
replace	6.10		
type	1.18		
Printer control program	2.18		
Printer settings.....	2.8		
access	2.9		
properties tabs			
Windows 2000/XP.....	2.17		
Windows 95/98/Me	2.10		
Windows NT 4.0.....	2.15		
Printing a document	2.6		
Priority fax.....	5.31		
Q			
Quality			
copy.....	3.5		
fax.....	5.3		
print.....	2.11		
R			
Reception modes	5.14		
Redial			
automatic	5.9		
dialled number.....	5.10		
received number	5.11		
Remote test	6.20		
Replace, print cartridge	6.10		
from SF-430	6.11		
from the computer	6.14		

Reports, print.....	5.36
Restrict	
colour copy	1.43
outgoing call.....	1.44
Reverse page order	
copy.....	3.8
print.....	2.10
Ringer volume, adjust	1.41

S

Scan	
from SF-430	4.2
TWAIN-enabled software....	4.6
Scan monitor	4.2
Search for numbers.....	5.27
Set up	
AC power cord	1.10
document input support	1.8
document output support ...	1.8
extension phone	1.9
fax number and name.....	1.37
handset	1.8
paper input support.....	1.11
print cartridge	1.13
printer cable	1.10
system	1.34
telephone line.....	1.9
Shading, adjust	6.20
Software	
install	1.21
overview	1.19
system requirements	1.20
uninstall.....	1.29
Speaker volume, adjust	1.42
Specialty paper	
guidelines	2.3
load	2.4
Speed dial	5.23

T

Toll save fax.....	5.12
Troubleshooting	
colour printing problem	7.15
fax problem.....	7.9
general printing problem ...	7.12
jams.....	7.2
paper feeding problem	7.11
print quality problem	7.16
scanning problem.....	7.18
Two-sided print	2.14

U

Uninstall, software	
MFP driver.....	1.29
SmarThru	1.30
using CD-ROM	1.33
Unpacking	1.2

V

Voice request	5.11
---------------------	------

W

Web smoothing	2.11
---------------------	------

Z

Zoom rate, set for copy	3.7
-------------------------------	-----

Free Manuals Download Website

<http://myh66.com>

<http://usermanuals.us>

<http://www.somanuals.com>

<http://www.4manuals.cc>

<http://www.manual-lib.com>

<http://www.404manual.com>

<http://www.luxmanual.com>

<http://aubethermostatmanual.com>

Golf course search by state

<http://golfingnear.com>

Email search by domain

<http://emailbydomain.com>

Auto manuals search

<http://auto.somanuals.com>

TV manuals search

<http://tv.somanuals.com>