

For Customer in China

根据中华人民共和国信息产业部第39号令《电子信息产品污染控制管理办法》及标准中要求的“有毒有害物质或元素名称及含量”等信息，本产品相关信息请参考以下链接：

<http://pro.sony.com.cn>

SONY®

SOLID-STATE MEMORY CAMCORDER

PMW-500

SOLID-STATE MEMORY CAMCORDER PMW-500

The supplied CD-ROM includes operation manuals for the PMW-500 Solid-State Memory Camcorder (English, Japanese, French, German, Italian, Spanish and Chinese versions) in PDF format.
For more details, see “Using the CD-ROM” on page 14.

出版日期：2011年3月

PMW-500
(SYM)
4-260-128-03 (1)

Sony Corporation

<http://www.sony.net/>
Printed on recycled paper.

Printed in Japan
2011.03 32
© 2010

XDCAM™ Power HAD™ FX SxS

MPEG HD422 CINEALTA i

OPERATION MANUAL **English**
1st Edition (Revised 2)



WARNING

To reduce the risk of fire or electric shock, do not expose this apparatus to rain or moisture.

To avoid electrical shock, do not open the cabinet. Refer servicing to qualified personnel only.

Important Safety Instructions

- Read these instructions.
- Keep these instructions.
- Heed all warnings.
- Follow all instructions.
- Do not use this apparatus near water.
- Clean only with dry cloth.
- Do not block any ventilation openings. Install in accordance with the manufacturer's instructions.
- Do not install near any heat sources such as radiators, heat registers, stoves, or other apparatus (including amplifiers) that produce heat.
- Do not defeat the safety purpose of the polarized or grounding-type plug. A polarized plug has two blades with one wider than the other. A grounding-type plug has two blades and a third grounding prong. The wide blade or the third prong are provided for your safety. If the provided plug does not fit into your outlet, consult an electrician for replacement of the obsolete outlet.
- Protect the power cord from being walked on or pinched particularly at plugs, convenience receptacles, and the point where they exit from the apparatus.
- Only use attachments/accessories specified by the manufacturer.
- Refer all servicing to qualified service personnel. Servicing is required when the apparatus has been damaged in any way, such as power-supply cord or plug is damaged, liquid has been spilled or objects have fallen into the apparatus, the apparatus has been exposed to rain or

moisture, does not operate normally, or has been dropped.

WARNING

Excessive sound pressure from earphones and headphones can cause hearing loss. In order to use this product safely, avoid prolonged listening at excessive sound pressure levels.

For the customers in the U.S.A.

This equipment has been tested and found to comply with the limits for a Class B digital device, pursuant to Part 15 of the FCC Rules. These limits are designed to provide reasonable protection against harmful interference in a residential installation. This equipment generates, uses, and can radiate radio frequency energy and, if not installed and used in accordance with the instructions, may cause harmful interference to radio communications. However, there is no guarantee that interference will not occur in a particular installation. If this equipment does cause harmful interference to radio or television reception, which can be determined by turning the equipment off and on, the user is encouraged to try to correct the interference by one or more of the following measures:

- Reorient or relocate the receiving antenna.
- Increase the separation between the equipment and receiver.
- Connect the equipment into an outlet on a circuit different from that to which the receiver is connected.
- Consult the dealer or an experienced radio/TV technician for help.

You are cautioned that any changes or modifications not expressly approved in this manual could void your authority to operate this equipment.

All interface cables used to connect peripherals must be shielded in order to comply with the limits for a digital device pursuant to Subpart B of Part 15 of FCC Rules.

If you have any questions about this product, you may call;

Sony Customer Information Service Center
1-800-222-7669 or <http://www.sony.com/>

Declaration of Conformity

Trade Name : SONY
Model : PMW-500
Responsible party : Sony Electronics Inc.
Address : 16530 Via Esprillo,
San Diego, CA
92127 U.S.A.

Telephone Number : 858-942-2230

This device complies with part 15 of the FCC Rules. Operation is subject to the following two conditions: (1) this device may not cause harmful interference, and (2) this device must accept any interference received, including interference that may cause undesired operation.

For the customers in Canada

This Class B digital apparatus complies with Canadian ICES-003.

For the customers in Europe

This product with the CE marking complies with the EMC Directive issued by the Commission of the European Community. Compliance with this directive implies conformity to the following European standards:

- EN55103-1: Electromagnetic Interference(Emission)
- EN55103-2: Electromagnetic Susceptibility(Immunity)

This product is intended for use in the following Electromagnetic Environments: E1 (residential), E2 (commercial and light industrial), E3 (urban outdoors), E4 (controlled EMC environment, ex. TV studio).

The manufacturer of this product is Sony Corporation, 1-7-1 Konan, Minato-ku, Tokyo, Japan.

The Authorized Representative for EMC and product safety is Sony Deutschland GmbH, Hedelfinger Strasse 61, 70327 Stuttgart, Germany.

For the State of California, USA only

Perchlorate Material - special handling may apply, See

www.dtsc.ca.gov/hazardouswaste/perchlorate

Perchlorate Material : Lithium battery contains perchlorate.

For the customers in Taiwan only



廢電池請回收

AVERTISSEMENT

Afin de réduire les risques d'incendie ou d'électrocution, ne pas exposer cet appareil à la pluie ou à l'humidité.

Afin d'écartier tout risque d'électrocution, garder le coffret fermé. Ne confier l'entretien de l'appareil qu'à un personnel qualifié.

AVERTISSEMENT

Une pression acoustique excessive en provenance des écouteurs ou du casque peut provoquer une baisse de l'acuité auditive.

Pour utiliser ce produit en toute sécurité, évitez l'écoute prolongée à des pressions sonores excessives

Pour les clients au Canada

Cet appareil numérique de la classe B est conforme à la norme NMB-003 du Canada.

Pour les clients en Europe

Ce produit portant la marque CE est conforme à la Directive sur la compatibilité électromagnétique (EMC) émise par la Commission de la Communauté européenne.

La conformité à cette directive implique la conformité aux normes européennes suivantes :

- EN55103-1 : Interférences électromagnétiques (émission)
- EN55103-2 : Sensibilité électromagnétique (immunité)

Ce produit est prévu pour être utilisé dans les environnements électromagnétiques suivants : E1 (résidentiel), E2 (commercial et industrie légère), E3 (urbain extérieur) et E4 (environnement EMC contrôlé, ex. studio de télévision).

Le fabricant de ce produit est Sony Corporation, 1-7-1 Konan, Minato-ku, Tokyo, Japon.

Le représentant autorisé pour EMC et la sécurité des produits est Sony Deutschland GmbH, Hedelfinger Strasse 61, 70327 Stuttgart, Allemagne.

WARNUNG

Um die Gefahr von Bränden oder elektrischen Schlägen zu verringern, darf dieses Gerät nicht Regen oder Feuchtigkeit ausgesetzt werden.

Um einen elektrischen Schlag zu vermeiden, darf das Gehäuse nicht geöffnet werden. Überlassen Sie Wartungsarbeiten stets nur qualifiziertem Fachpersonal.

WARNUNG

Zu hoher Schalldruck von Ohrhörern und Kopfhörern kann Gehörschäden verursachen.

Um dieses Produkt sicher zu verwenden, vermeiden Sie längeres Hören bei sehr hohen Schalldruckpegeln.

Für Kunden in Europa

Dieses Produkt besitzt die CE-Kennzeichnung und erfüllt die EMV-Richtlinie der EG-Kommission.

Angewandte Normen:

- EN55103-1: Elektromagnetische Verträglichkeit (Störaussendung)
- EN55103-2: Elektromagnetische Verträglichkeit (Störfestigkeit)

Für die folgenden elektromagnetischen Umgebungen: E1 (Wohnbereich), E2 (kommerzieller und in beschränktem Maße industrieller Bereich), E3 (Stadtbereich im Freien) und E4 (kontrollierter EMV-Bereich, z.B. Fernsehstudio).

Der Hersteller dieses Produkts ist Sony Corporation, 1-7-1 Konan, Minato-ku, Tokyo, Japan.

Der autorisierte Repräsentant für EMV und Produktsicherheit ist Sony Deutschland GmbH, Hedelfinger Strasse 61, 70327 Stuttgart, Deutschland.

Table of Contents

Foreword	11
Before Use.....	11
Mode Indications in This Manual	11

Chapter 1 : Overview

Features	12
Using the CD-ROM	14
Reading the CD-ROM Manuals	14
Locations and Functions of Parts and Controls.....	15
Power Supply	15
Accessory Attachments.....	16
Operating and Connectors Section.....	17
LCD Monitor.....	26
HDVF-20A Viewfinder (Optional).....	28
CBK-VF01 Viewfinder (Optional)	29
Status Display on the Viewfinder Screen.....	30

Chapter 2 : Preparations

Preparing a Power Supply	35
Using a Battery Pack.....	35
Using AC Power	36
Attaching the Viewfinder	37
Attaching the Viewfinder.....	37
Adjusting the Viewfinder Position.....	37
Using the BKW-401 Viewfinder Rotation Bracket	38
Detaching the Eyepiece.....	39
Adjusting the Viewfinder Focus and Screen.....	39
Setting the Area of Use	40
Setting the Date/Time of the Internal Clock	41
Mounting and Adjusting the Lens.....	42
Adjusting the Flange Focal Length.....	42
Preparing the Audio Input System	43
Connecting a Microphone to the MIC IN Connector.....	43
Connecting Microphones to the AUDIO IN Connectors.....	44

Attaching a UHF Portable Tuner (for a UHF Wireless Microphone System)	45
Connecting Line Input Audio Equipment	47
Tripod Mounting	48
Connecting a Video Light	49
Using the Shoulder Strap	49
Adjusting the Shoulder Pad Position	50

Chapter 3 : Adjustments and Settings

Setting the Video Format	51
Selecting the Recording Mode	53
Changing the Video Format	53
Adjusting the Black Balance and the White Balance	54
Adjusting the Black Balance	54
Adjusting the White Balance	55
Setting the Electronic Shutter	57
Shutter Modes	57
Selecting the Shutter Mode and Shutter Speed	57
Changing the Reference Value for Automatic Iris Adjustment	59
Adjusting the Audio Level	60
Manually Adjusting the Audio Levels of the Audio Inputs from the AUDIO IN CH-1/CH-2 Connectors	60
Manually Adjusting the Audio Level of the MIC IN Connector	60
Recording Audio on Channels 3 and 4	61
Setting the Time Data	62
Setting the Timecode	62
Setting the User Bits	63
Synchronizing the Timecode	63
Setting Shot Data	65
Creating a Shot ID	65
Checking Camcorder Settings and Status Information (Status Screens)	66

Chapter 4 : Shooting

Handling SxS Memory Cards	68
About SxS Memory Cards	68
Loading and Ejecting SxS Memory Cards	69
Selecting the SxS Memory Card to Use	70

Formatting (Initializing) SxS Memory Cards	70
If You Load a Memory Card Formatted in the Different Recording Mode from the Mode Selected on the Camcorder	71
Checking the Remaining Recording Time	71
Restoring SxS Memory Cards	72
Handling USB Flash Drives	73
Formatting (Initializing) USB Flash Drives	73
Restoring USB Flash Drives	74
Basic Operations	74
Playing Recorded Clips	76
Deleting Recorded Clips	77
Advanced Operations	77
Recording Shot Marks	77
Setting OK Marks	78
Starting to Record from Pre-stored Video (Picture Cache Function)	78
Recording Time-lapse Video (Interval Rec Function)	79
Shooting Stop Motion Animations (Frame Rec Function)	81
Shooting with Slow & Quick Motion	82
Recording with the Clip Continuous Rec Function	83
Framing Shots with the Freeze Mix Function	84
Recording Proxy Data	85
Recording Proxy Data While Recording Clips	85
Recording Proxy Data for Existing Clips	86
Deleting All Proxy Data from a USB Flash Drive	86
Planning Metadata Operations	87
Loading a Planning Metadata File into Camcorder's Internal Memory	87
Defining Clip Names in Planning Metadata	88
Defining Shot Mark Names in Planning Metadata	90

Chapter 5 : Clip Operations

Clip Playback	91
Thumbnail Screen	91
Playing Clips	94
Using Thumbnails to Search Inside Clips	95
Thumbnail Operations	96
THUMBNAIL Menu Configuration	96
Basic THUMBNAIL Menu Operations	98
Changing the Thumbnail Screen Type	98
Displaying Clip Properties	100
Adding and Deleting OK, NG or KP Marks	101

Protecting Clips.....	102
Copying Clips	102
Deleting Clips.....	103
Displaying the Expand Thumbnail Screen.....	104
Displaying the Essence Mark Thumbnail Screen	105
Adding and Deleting Shot Marks.....	106
Changing Clip Index Pictures	106
Dividing Clips	106

Chapter 6 : Menu and Detailed Settings

Setup Menu Organization and Levels.....	107
Setup Menu Organization	107
Setup Menu Levels.....	107
Basic Setup Menu Operations	109
Menu List.....	111
USER Menu (Factory Default Configuration).....	111
OPERATION Menu.....	112
PAINT Menu.....	129
MAINTENANCE Menu	135
FILE Menu	150
Assigning Functions to Assignable Switches	155
Functions That Can Be Assigned to the ASSIGN. 0 Switch	155
Functions That Can Be Assigned to the ASSIGN. 2 Switch	156
Functions That Can Be Assigned to the ASSIGN. 1 and 3 Switches, the ASSIGNABLE 4 and 5 Switches, and the COLOR TEMP. Button.....	156
Functions That Can Be Assigned to the RET Button on the Lens	159

Chapter 7 : Saving and Loading User Setting Data

Saving and Loading Settings.....	160
Saving Setting Data.....	160
Loading Setting Data.....	161
Resetting a File after Changing Its Contents.....	162
Saving and Loading Scene Files	162
Saving Scene Files	162
Loading Scene Files	163
Saving and Loading Lens Files	164
Setting Lens File Data.....	164
Saving Lens Files	164
Loading Lens Files	164

Loading Lens Files Automatically	165
Saving and Loading User Files	165
Saving User Files	165
Loading Setting Data.....	166

Chapter 8 : Connecting External Devices

Connecting External Monitors	167
Operating Clips with a Computer	169
Using the ExpressCard Slot of a Computer	169
USB Connection with a Computer.....	169
Connecting an External Device (i.LINK Connection)	171
Recording the Camera Picture on an External Device.....	171
Nonlinear Editing	172
Recording External Input Signals	172
Configuring a Shooting and Recording System	173

Chapter 9 : Maintenance

Testing the Camcorder	174
Maintenance	174
Cleaning the Viewfinder	174
Note about the Battery Terminal.....	175
Operation Warnings.....	176
Error Indication	176
Warning Indication.....	177

Appendix

Important Notes on Operation	184
Exchanging the Battery of the Internal Clock	186
Specifications	186
General	186
Camera Block.....	187
Audio Block	188
Display	188
Media Block	188
Inputs/Outputs	188
Supplied Accessories	189
Recommended Additional Equipment	189

Chart of Optional Components and Accessories	191
About i.LINK	192
MPEG-4 Visual Patent Portfolio License	193
MPEG-2 Video Patent Portfolio License	193
About Bitmap Fonts	193
About OpenSSL	194
Index.....	197

Foreword

Before Use

After purchasing the PMW-500 Solid-State Memory Camcorder, before operating, it is necessary to set the area of use. (Unless this setting is made, the camcorder will not operate.)

For details of these settings, see “Setting the Area of Use” (page 40).

Note

Before attaching/removing optional components or accessories to/from the PMW-500 (referred to as “the camcorder”), be sure to turn the power of the camcorder off.

Mode Indications in This Manual

Some functions and information are available only when this camcorder is in a specific operating mode. This manual indicates those modes by using the following marks. When these marks appear, the associated function or information is available only in that mode.

HD

HD mode: When OPERATION >Format >HD/SD in the setup menu is set to [HD].

UDF

UDF mode: When OPERATION >Format >File System in the setup menu is set to [UDF].

FAT

FAT mode: When OPERATION >Format >File System in the setup menu is set to [FAT].

FAT-HD

FAT-HD mode: When OPERATION >Format >File System in the setup menu is set to [FAT] and OPERATION >Format >HD/SD in the setup menu is set to [HD].

FAT-SD

FAT-SD mode: When OPERATION >Format >File System in the setup menu is set to [FAT] and OPERATION >Format >HD/SD in the setup menu is set to [SD].

Chapter 1 Overview

Features

2/3-inch full-HD “PowerHAD FX” CCDs

- IT (Interline Transfer) 2/3-inch progressive image sensors with 207 million pixels, for full HD resolution (1920 × 1080)
- “PowerHAD FX” CCDs, featuring a signal processing ASIC with 14-bit A/D converters. These new image sensor technologies enable the capture of very high-quality images, with F11 (59.94i) and F12 (50i) sensitivity and an SN ratio of 59 dB.¹⁾

1) With noise suppression on (off value is 54 dB) Noise suppression uses proprietary Sony signal processing technology to suppress noise in highfrequency regions.

SxS memory cards as recording media

Using SxS memory cards, the camcorder offers nonlinear capabilities such as instant random access and file-based operation.

You can choose FAT or UDF as the file system for recording media.

Light weight, low power consumption

Design features custom video signal processing ICs, and SxS memory card recording enable fanless operation and power consumption of 27 W or less. The camcorder’s light weight (3.4 kg (7 lb 7.9 oz)) and low center of gravity make it easy to carry on the shoulder while ensuring superior stability.

HD recording using the “MPEG-2 Long GOP” codec and SD recording in MPEG IMX50/DVCAM format

The camcorder records 1920 × 1080, 1440 × 1080, and 1280 × 720 HD images using “MPEG-2 Long GOP” codec compression.

For recording in FAT mode, it offers a choice of bit rates: either 35 Mbps (HQ mode) or 25 Mbps (SP mode).

For recording in UDF mode, it offers a choice of bit rates: either 35 Mbps (HQ mode) or 50 Mbps (HD422 mode).

By utilizing an efficient compression format, the camcorder records high-quality HD images for long recording time of approx. 60 minutes at 50 Mbps (HD422 mode) or approx. 90 minutes at 35 Mbps (HQ mode) on a single 32-GB SxS memory card (when the recording mode is UDF).

It can also record and play two SD formats: MPEG IMX 50 Mbps and DVCAM 25 Mbps.¹⁾

1) CBK-MD01 SD Record and Playback Key required.

For details, contact a Sony service representative

Multi-format support

The camcorder supports interlace format recording (1080/59.94i or 1080/50i), progressive format recording (1080/29.97P, 1080/23.98P, 720/59.94P, 720/29.97P, 720/23.98P, or 1080/25P, 720/50P, 720/25P), thus offering the flexibility needed for worldwide HD recording. It also supports recording and playback of SD signals (both NTSC and PAL). The camcorder has an optional capability to record and play back SD signals in IMX/DVCAM format, and can output HD signals down-converted to SD.

A variety of functions for improved performance under various shooting conditions

- Picture Cache function
- Optical ND filters and electrical CC filters
- Hyper gamma
- Slow shutter function
- Clip Continuous Rec function
- Frame Recording function
- Time lapse function (interval recording)
- Slow & quick motion function
- Freeze mix function
- Live & Play function
- Digital extender function¹⁾
- Focus magnification function
- Assignable switches

- 3.5-inch high-resolution color LCD monitor
 - Remote control
- 1) When the optional CBK-HD02 SDI/Composite Input and 50-pin Interface is installed

Recording data to USB flash drives and reading data from USB flash drives (UDF mode)

You can connect USB flash drives to the external device connector to record proxy data or read planning metadata. You can also save setup menu settings to USB flash drives and load menu settings from USB flash drives into the camcorder.

Wireless LAN support

You can connect this camcorder to a computer over a wireless LAN (Wi-Fi connection) by installing the optional CBK-UPG01 Hardware Upgrade Key and connecting the optional CBK-WA01 Wi-Fi Adapter to the external device connector.

A Wi-Fi connection allows you to transfer planning metadata from a computer to this camcorder, and to transfer clips and other files from this camcorder to a computer. You can also use the Live Logging function to transfer proxy AV data to a computer as you shoot, for logging of the video currently being shot.

Inherits unique features of XDCAM series

The camcorder inherits the workflow features of the XDCAM series, including thumbnail display and metadata management, and improves them by introducing an improved man-machine interface.

Supports two viewfinder types

Depending on the application, you can use either the optional HDVF series viewfinder or the CBK-VF01 color viewfinder.

Camcorder system configuration

When you install the optional CBK-HD02 SDI/Composite Input and 50-pin Interface, you can mount the XDCA-55 HD Camera Adaptor and connect the XDCU-50 HD Camera Extension Unit to configure a system for shooting and recording.

When the CBK-HD02 is installed, you can also connect the HDCA-702 MPEG TS Adaptor instead of the camera adaptor. This allows you to convert this camcorder's HDSDI output to a MPEG HD transport stream.

Using the CD-ROM

Two CD-ROMs are supplied with the camcorder.

The CD-ROM labeled “Manuals for Solid-State Memory Camcorder” contains the PDF files of OPERATION MANUAL and SUPPLEMENT for the camcorder (English, Japanese, French, German, Italian, Spanish and Chinese).

The CD-ROM labeled “Utility Software for XDCAM” contains application and device driver software required to access to SxS memory cards from a computer and to manage material shot with the camcorder.

Information about how to install the software is provided in PDF format.

Note

You must install the SxS device driver and SxS UDF driver software on your computer if it is equipped with an ExpressCard slot and you want to use it to access SxS memory cards, if you want to connect the camcorder to your computer, and if you want to connect an optional SBAC-US10 SxS Memory Card USB Reader/Writer to the computer.

Reading the CD-ROM Manuals

Preparations

The following program must be installed on your computer in order to read the documents contained on the CD-ROM.

Adobe Reader Version 6.0 or higher

Memo

If Adobe Reader is not installed, you can download it from the following URL:

<http://www.adobe.com/>

Adobe and Adobe Reader are trademarks of Adobe Systems Incorporated in the United States and/or other countries.

To read the documents

Do the following:

1 Insert the CD-ROM in your CD-ROM drive.

A cover page appears automatically in your browser.

If it does not appear automatically in the browser, double-click on the index.htm file on the CD-ROM.

2 Select and click on the manual that you wish to read.

This opens the PDF file.

Memo

The files may not be displayed properly, depending on the version of Adobe Reader. In such a case, install the latest version you can download from the URL mentioned in “Preparations” above.

Note

If you have lost or damaged the CD-ROM, you can purchase a new one to replace it. Contact a Sony service representative.

Locations and Functions of Parts and Controls

Power Supply

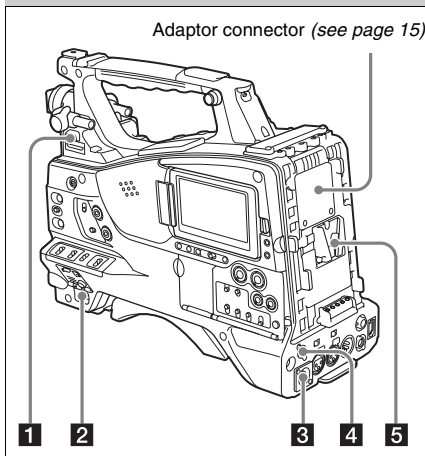

1 LIGHT switch

Determines how a video light connected to the LIGHT connector (see page 16) is turned on and off.

AUTO: When the POWER switch of the video light is in the on position, the video light is turned on automatically while the camcorder is recording.

MANUAL: You can turn the video light on or off manually, using its own switch.

Note

When the camcorder is set for recording in Picture Cache mode, it is not possible to turn on the light before operation to start recording is carried out (or while data is being stored in memory).

2 POWER switch

Turns the main power supply on and off.

3 DC IN (DC power input) connector (XLR type, 4-pin, male)

To operate the camcorder from an AC power supply, connect an optional DC power cord to this terminal and then connect the cord to the DC output terminal of the BC-L70, BC-L160, or another battery charger.

4 DC OUT 12V (DC power output) connector (4-pin, female)

Supplies power for an optional WRR-860C/861/862 UHF Synthesized Diversity Tuner (maximum 0.5 A).

Note

Do not connect any equipment other than the UHF synthesized diversity tuner.

5 Battery attachment shoe

Attach a BP-GL95/GL65/L80S/L60S Battery Pack. Alternatively, you can attach an AC-DN2B/DN10 AC Adaptor to operate the camcorder on AC power supply.

For details, see "Preparing a Power Supply" (page 35).

For details, see "Attaching a UHF Portable Tuner (for a UHF Wireless Microphone System)" (page 45).

Note

For your safety, and to ensure proper operation of the camcorder, Sony recommends the use of the following battery packs: BP-GL95, BP-GL65, BP-L60S, and BP-L80S.

Adaptor connector

Enables connection of an XDCA-55 HD Camera Adaptor or an HDCA-702 MPEG TS Adaptor. To connect an adaptor, remove the cover from the connector and install the optional CBK-HD02 SDI/COMPOSITE Input and 50 Pin Interface.

Accessory Attachments

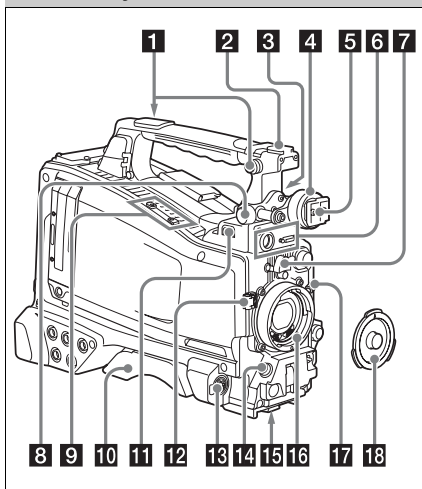

1 Shoulder strap fitting

Attach the supplied shoulder strap (*see page 49*).

2 Accessory fitting shoe

Attach an optional accessory such as a video light (*see page 49*).

3 Viewfinder front-to-back positioning lever

To adjust the viewfinder position in the front-to-back direction, loosen this lever and the LOCK knob. After adjustment, retighten this lever and the LOCK knob.

4 Viewfinder left-to-right positioning ring

Loosen this ring to adjust the left-to-right position of the viewfinder (*see page 37*).

5 Viewfinder fitting shoe

Attach the viewfinder.

6 VF (viewfinder) connectors (26-pin, rectangular and 20-pin, round)

The analog interface connector (20-pin) is for connection of an HDVF series viewfinder, and the digital interface connector (26-pin) is for connection of an HD viewfinder CBK-VF01. Use a connection cable to connect your viewfinder to the corresponding connector.

Note

Do not connect viewfinders to both connectors at the same time.

7 Lens mount securing rubber

After locking the lens in position using the lens locking lever, fit this rubber over the lower of the two projections. This fixes the lens mount, preventing it from coming loose.

8 Viewfinder front-to-back positioning knob (LOCK knob)

Loosen this knob to adjust the front-to-back position of the viewfinder (*see page 37*).

9 Fitting for optional microphone holder

Fit an optional CAC-12 Microphone Holder (*see page 44*).

10 Shoulder pad

Raise the shoulder pad fixing lever to adjust the position in the front-to-rear direction. Adjust the position for maximum convenience when operating the camcorder on your shoulder (*see page 50*).

11 LIGHT (video light) connector (2-pin, female)

A video light with a maximum power consumption of 50 W, such as the Anton Bauer Ultralight 2 or equivalent can be connected (*see page 49*).

12 Lens cable clamp

Clamp a lens cable.

13 MIC IN (microphone input) (+48 V) connector (XLR type, 5-pin, female)

Connect a stereo microphone to this connector. The power (+48 V) is supplied via this connector.

14 LENS connector (12-pin)

Connect a lens cable to this connector.

Note

When connecting or disconnecting the lens cable to this connector, power off the camcorder first.

15 Tripod mount

When using the camcorder on a tripod, attach the tripod adaptor (optional).

16 Lens mount (special bayonet mount)

Attach the lens.

Consult a Sony service representative for information about available lenses.

17 Lens locking lever

After inserting the lens in the lens mount, rotate the lens mount ring with this lever to lock the lens in position.

After locking the lens, be sure to use the lens mount securing rubber to prevent the lens from becoming detached.

18 Lens mount cap

Remove by pushing up the lens locking lever. When no lens is mounted, keep this cap fitted for protection from dust.

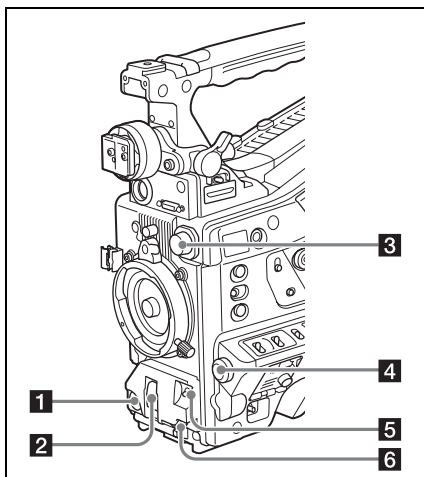
Operating and Connectors Section**Front****1 REC START (recording start) button**

Press to start recording. Press it again to stop recording. The effect is the same as that of the REC button on the lens.

2 SHUTTER selector

Set to ON to use the electronic shutter. Push to SELECT to switch the shutter speed or shutter mode setting. When this switch is operated, the new setting appears on the viewfinder screen for about three seconds.

For details, see "Setting the Electronic Shutter" (page 57).

3 FILTER selector

Switches between four ND filters built into this camcorder.

When this selector is used, the new setting appears on the viewfinder screen for about three seconds.

FILTER selector setting	ND filter
1	CLEAR
2	$1/4$ ND (attenuates light to approximately $1/4$)
3	$1/16$ ND (attenuates light to approximately $1/16$)
4	$1/64$ ND (attenuates light to approximately $1/64$)

You can change a MAINTENANCE menu setting so that different white balance settings can be stored for different FILTER selector positions. This allows you to automatically obtain optimum white balance for the current shooting conditions in linkage with the filter selection.

For details, see "Adjusting the White Balance" (page 55).

4 MENU knob

Changes the item selection or a setting within the menu (see page 109).

5 AUTO W/B BAL (automatic white/black balance adjustment) switch

Activates the automatic white/black balance adjustment functions.

WHITE: Adjust the white balance automatically.

If the WHITE BAL switch (see page 19) is set to A or B, the white balance setting is stored in the corresponding memory. If the WHITE BAL switch is set to PRST, the automatic white balance adjustment function does not operate.

BLACK: Adjust the black set and black balance automatically.

You can use the AUTO W/B BAL switch even when the ATW (Auto Tracing White Balance) function is operating.

If you push the switch to the WHITE side once more during the automatic white balance adjustment, the adjustment is cancelled and the

white balance setting returns to the original setting.

If you push the switch to the BLACK side once more during the automatic black balance adjustment, the adjustment is cancelled and the black balance setting returns to the original setting.

6 MIC (microphone) LEVEL control

Adjusts the input level of audio channels 1, 2, 3 and 4 (see page 60).

Right side (near the front)

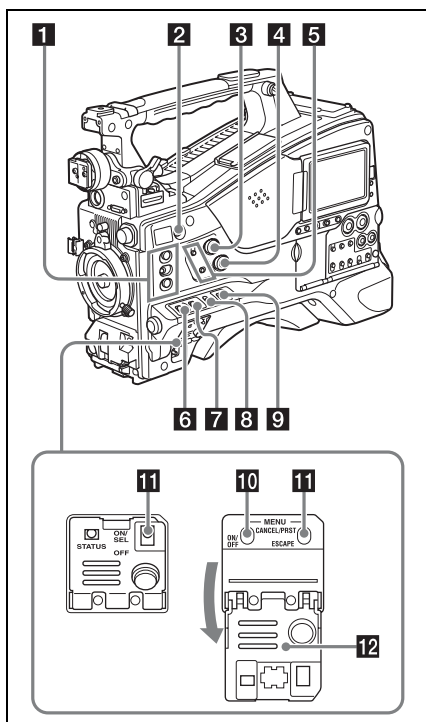

1 ASSIGN. (assignable) 1/2/3 switches

You can assign the desired functions to these switches on OPERATION > Assignable SW in the setup menu (see page 155).

Off is assigned to the ASSIGN 1/2/3 switches as the factory default setting.

The ASSIGN.1/3 switches are provided with an indicator to show whether a function is assigned to the switch (ON) or not (OFF).

2 COLOR TEMP. (color temperature) button

Press to light the button and change the color temperature for shooting (factory default setting). You can use this as an assignable switch (see page 155).

3 ALARM (alarm tone volume adjustment) knob

Controls the volume of the warning tone that is output via the built-in speaker or optional earphones. When the knob is turned to the minimum position, no sound can be heard. However, if MAINTENANCE > Audio > Min Alarm Volume in the setup menu is set to [Set], the alarm tone is audible even when this volume control is at the minimum position.

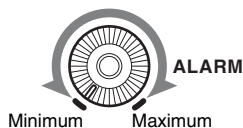

4 MONITOR (monitor volume adjustment) knob

Controls the volume of the sound other than the warning tone that is output via the built-in speaker or earphones. When the knob is turned to the minimum position, no sound can be heard.

5 MONITOR (audio monitor selection) switches

By means of combinations of the two switches, you can select audio that you want to hear through the built-in speaker or earphones.

Position of down-side switch: CH-1/2

Position of up-side switch	Audio output
CH-1/CH-3	Channel 1 audio
MIX	Channels 1 and 2 mixed audio (stereo) ^{a)}
CH-2/CH-4	Channel 2 audio

Position of down-side switch: CH-3/4

Position of up-side switch	Audio output
CH-1/CH-3	Channel 3 audio
MIX	Channels 3 and 4 mixed audio (stereo) ^{a)}
CH-2/CH-4	Channel 4 audio

- a) By connecting stereo headphones to the EARPHONE jack, you can hear the audio in stereo. (Under MAINTENANCE >Audio in the setup menu, Headphone Out must be set to STEREO.)

6 ASSIGN. (assignable) 0 switch

You can assign the desired function to this switch on OPERATION >Assignable SW in the setup menu (see page 156).

Off is assigned to this switch when the camcorder is shipped from the factory.

This is a momentary type switch. Each press of the switch turns the function assigned to this switch on or off.

7 GAIN selector

Switches the gain of the video amplifier to match the lighting conditions during shooting. The gains corresponding to the L, M, and H settings can be selected on OPERATION >Gain Switch in the setup menu (see page 119). (The factory settings are L=0 dB, M=6 dB, and H=12 dB.)

When this switch is adjusted, the new setting appears on the viewfinder screen for about three seconds.

8 OUTPUT/DCC (output signal/dynamic contrast control) switch

Switches the video signal output from the camera module, between the following two.

BARS: Output the color bar signal.

CAM: Output the video signal being shot. When this is selected, you can switch DCC¹⁾ on and off.

- 1) **DCC (Dynamic Contrast Control):** Against a very bright background with the iris opening adjusted to the subject, objects in the background will be lost in the glare. The DCC function will suppress the high intensity and restore much of the lost detail and is particularly effective in the following cases.

- Shooting people in the shade on a sunny day
- Shooting a subject indoors, against a background through a window
- Any high contrast scene

9 WHITE BAL (white balance memory) switch

Controls adjustment of the white balance.

PRST: Adjust the color temperature to the preset value (the factory default setting: 3200K).

Use this setting when you have no time to adjust the white balance.

A or B: Recall the white balance adjustment settings already stored in A or B. Push the

AUTO W/B BAL switch (see page 17) on the WHITE side, to automatically adjust the white balance, and save the adjustment settings in memory A or memory B.

B (ATW¹⁾): When this switch is set to B and OPERATION >White Setting >White Switch is set to [ATW] in the setup menu, ATW is activated.

You can use the AUTO W/B BAL switch even when ATW is in use.

When this switch is adjusted, the new setting appears on the viewfinder screen for about three seconds.

- 1) **ATW (Auto Tracing White Balance):** The white balance of the picture being shot is adjusted automatically for varying lighting conditions.

10 MENU ON/OFF switch

To use this switch, open the cover.

This switch is used to display the menu on the viewfinder screen or the test signal screen. Each time the switch is pushed down, the menu screen is turned on and off.

The function of this switch is the same as that of the MENU button in the thumbnail screen operations section.

Note

This switch has different functions depending on whether or not a menu is displayed.

11 MENU CANCEL/PRST (preset) / ESCAPE switch

To use the MENU CANCEL/PRST/ESCAPE switch, open the cover.

Note

It is not possible to turn off the menu screen by closing the cover.

Use the switch in the following way when the menu is not displayed.

CANCEL/PRST: Each time this switch is pushed upward, a window to confirm the menu settings and status of the camcorder appears on the viewfinder screen (see page 66). The window consists of five pages, which are switched each time the switch is pushed upward. Each page is displayed for about 10 seconds.

ESCAPE: To clear the page immediately after display, push this switch down to the OFF position.

Use the switch in the following way when the menu is displayed.

CANCEL/PRST: Pushing this switch up to this position after a setting is changed in the setup menu displays the message to confirm whether the previous settings are cancelled. Pushing this switch up to this position again cancels the previous settings.

Pushing this switch up to this position before a setting is changed in the setup menu or after a setting change is cancelled in the setup menu displays the message to confirm whether the setting is reset to the initial value.

Pushing this switch up to this position again resets the settings to the initial value.

ESCAPE: Use this switch when the menu page, which has a hierarchical structure, is opened. Each time the switch is pushed to this position, the page returns to one stage higher in the hierarchy.

12 Cover

Open this cover to use the MENU ON/OFF switch or the MENU CANCEL/PRST/ESCAPE switch.

Right side (near the rear)

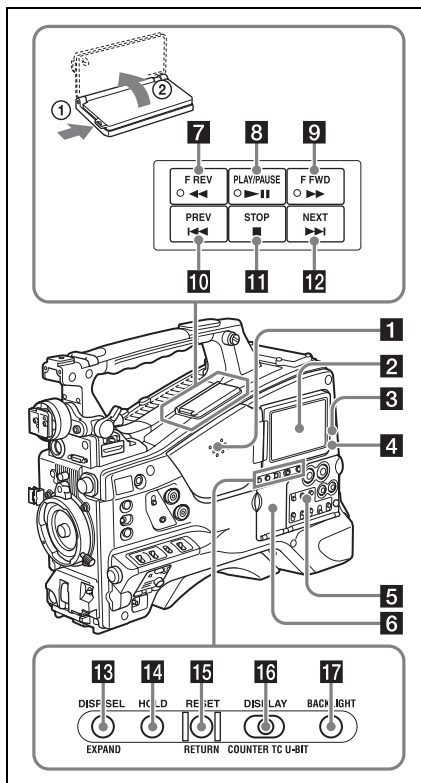

1 Built-in speaker

The speaker can be used to monitor E-E¹⁾ sound during recording, and playback sound during playback. The speaker also sounds alarms to reinforce visual warnings (*see page 176*).

If you connect earphones to the EARPHONE jack, the speaker output is suppressed automatically.

1) **E-E:** Abbreviation of "Electric-to-Electric". In E-E mode, video and audio signals input to the camcorder are output after passing through internal electric circuits only. This can be used to check input signals.

2 LCD monitor

Displays remaining battery capacity, remaining media capacity, audio levels, time data, and so on (*see page 26*).

Also allows you to check camera and playback pictures.

You can adjust the position and angle of the LCD monitor.

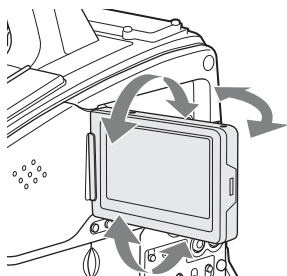

3 WARNING indicator

Lights up or flashes when an abnormality occurs (*see page 176*).

4 ACCESS lamp

Lights up in blue when data is written to or read from the recording media.

5 Protection cover of the audio control section

Open to access the audio control section (*see page 22*).

6 Protection cover of the thumbnail screen operations section

Open to access the thumbnail screen operations section (*see page 22*).

7 F REV (fast reverse) button and indicator

This plays back at high speed in the reverse direction. The playback speed changes in the order $\times 4 \rightarrow \times 15 \rightarrow \times 24$ with each press of the button. The indicator lights during high-speed playback in the reverse direction.

8 PLAY/PAUSE button and indicator

Press this button to view play back video images using the viewfinder screen or the LCD monitor. The indicator lights during playback.

Press this button again during playback to pause, outputting a still image. At this time the indicator flashes at a rate of once per second.

Pressing the F REV or F FWD button during playback or pause starts high speed playback in the forward or reverse direction.

9 F FWD (fast forward) button and indicator

This plays back at high speed in the forward direction. The playback speed changes in the order $\times 4 \rightarrow \times 15 \rightarrow \times 24$ with each press of the button. The indicator lights during high-speed playback in the forward direction.

10 PREV button

This jumps to the first frame of the current clip. If you press this together with the F REV button, the jump is to the first frame of the first recorded clip on the recording media.

If you press this button twice in rapid succession, the jump is to the first frame of the last preceding clip (or the first frame of the current clip when no preceding clips exist).

11 STOP button

Press this button to stop playback.

12 NEXT button

This jumps to the first frame of the next clip. If you press this together with the F FWD button, the jump is to the first frame of the last recorded clip on the recording media.

13 DISP SEL (display selection)/EXPAND (expand function) button

With each press of this button, the display in the LCD monitor changes as follows.

Display indication	Meaning
Video with superimposed information (CHAR)	The LCD monitor displays the same text information as the viewfinder.
Video without superimposed information (MONI)	The video only appears.
Status display (STATUS)	Counter indications, warnings, audio levels, and similar information appear. No video image appears.

If you press this button when the thumbnail screen is displayed, the duration of the selected clip is divided into fractions, and the first frame of each of the divisions is shown in a further thumbnail display (expand function). For an HD recorded MP4 clip, its duration is divided into 12. If an SD recorded AVI clip comprises multiple files, the divisions are displayed for the individual files.

For MP4 clips, each time you press this button the division is repeated. Hold down the SHIFT button and press this button to step back through the division process.

14 HOLD (display hold) button

Pressing this button instantly freezes the time data displayed in the LCD monitor. (The timecode generator continues running.) Pressing this button again releases the hold.

For details of the counter display, see page 27.

15 RESET/RETURN button

Resets the value shown in the time counter display in the LCD monitor. According to the settings of the PRESET/REGEN/CLOCK switch (see page 23) and the F-RUN/SET/R-RUN switch (see page 23), this button resets the display as follows.

Settings of switches	To reset
DISPLAY switch: COUNTER	Counter to 0:00:00:00
DISPLAY switch: TC PRESET/REGEN/CLOCK switch: PRESET F-RUN/SET/R-RUN switch: SET	Timecode to 00:00:00:00
DISPLAY switch: U-BIT PRESET/REGEN/CLOCK switch: PRESET F-RUN/SET/R-RUN switch: SET	User bits data ^{a)} to 00 00 00 00

a) Of the timecode bits for every frame recorded on the media, those bits which can be used to record useful information for the user such as scene number, shooting place, etc.

For details, see "Setting the Time Data" (page 62).

This button returns to the previous screen when pressed during thumbnail screen display, expand thumbnail screen display, or essence mark thumbnail screen display.

16 DISPLAY switch

This cycles the data displayed in the time counter display in the LCD monitor through the sequence COUNTER, TC, and U-BIT (see page 27).

COUNTER: Display the elapsed recording/playback time (hours, minutes, seconds, frames).

TC: Display timecode.

U-BIT: Display user bits data.

17 BRIGHT (brightness) button

Switches the brightness of the LCD monitor backlight.

Each press of the button selects the next setting in the order shown in the following table.

If you press the button with the LCD monitor off, the LCD backlight comes on in the H state.

Setting	LCD monitor backlight
H	High (select this to view the LCD monitor outdoors in the daytime)
M	Brightness between H and L
L	Low (select this to view the LCD monitor indoors or outdoors at night)
OFF	Off (the display is also off)

Thumbnail screen operations section and audio control section

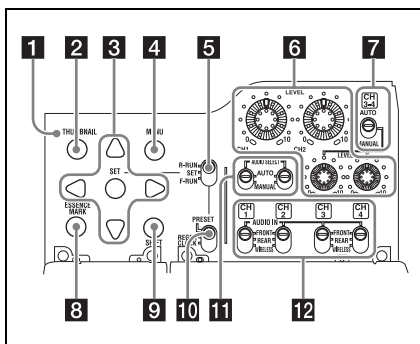

1 THUMBAIL indicator

This lights when thumbnail screen is displayed.

2 THUMBAIL button

Press this button to display the thumbnail screen (see page 91) and to carry out a thumbnail operation.

Press once more to return to the original display.

3 SET (set) button and arrow buttons

Use these buttons to make timecode and user bit settings, and for thumbnail screen operations (see page 98).

When the menu is displayed, press this button to select an item or to confirm the setting change.

4 MENU button

Each press of this button turns the setup menu display on and off.

The function of this button is the same as that of the MENU ON/OFF switch.

5 F-RUN/SET/R-RUN (free run/set/recording run) switch

Selects the operating mode of the internal timecode generator. The operating mode is set as explained below, depending on the position of the switch.

F-RUN: Timecode keeps advancing, regardless of whether the camcorder is recording. Use this setting when synchronizing the timecode with external timecode.

SET: Sets the timecode or user bits.

R-RUN: Timecode advances only during recording. Use this setting to have a consecutive timecode on the recording media.

For details, see "Setting the Timecode" (page 62) and "Setting the User Bits" (page 63).

6 LEVEL CH1/CH2/CH3/CH4 (audio channel 1/2/3/4 recording level) knobs

Adjust the audio levels to be recorded on channels 1, 2, 3, and 4 when the AUDIO SELECT CH1/CH2 and AUDIO SELECT CH 3-4 switches are set to MANUAL.

7 AUDIO SELECT CH 3-4 (audio channel 3/4 adjustment method selection) switch

Select the audio level adjustment method for each of audio channels 3 and 4.

AUTO: Automatic adjustment

MANUAL: Manual adjustment

8 ESSENCE MARK button

By pressing this button when a thumbnail display is on the screen, you can view the following thumbnail displays of the essence-marked frames of the selected clip, depending on the item selected in a list displayed on the screen.

All: Thumbnail display of all frames marked with essence marks.

Rec Start (in UDF mode): Thumbnail display of frames marked with Rec Start marks and of the first frames of clips (when the first frames are not marked with Rec Start marks).

Shot Mark1: Thumbnail display of the frames marked with Shot Mark 1

Shot Mark2: Thumbnail display of the frames marked with Shot Mark 2

You can also select Shot Mark 0 and Shot Mark 3 to Shot Mark 9.

If you have recorded clips by using planning metadata that defined names for Shot Mark 0 to Shot Mark 9, the defined names are displayed instead of the above item names in the list.

9 SHIFT button

Use this in combination with other buttons.

10 PRESET/REGEN (regeneration)/CLOCK switch

Selects the type of timecode to record.

PRESET: Record new timecode on the media.

REGEN: Record timecode continuous with the existing timecode recorded on the media. Regardless of the setting of the F-RUN/SET/R-RUN switch, the camcorder operates in R-RUN mode.

CLOCK: Record timecode synchronized to the internal clock. Regardless of the setting of the F-RUN/SET/R-RUN switch, the camcorder operates in F-RUN mode.

11 AUDIO SELECT CH1/CH2 (audio channel 1/2 adjustment method selection) switches

Select the audio level adjustment method for each of audio channels 1 and 2.

AUTO: Automatic adjustment

MANUAL: Manual adjustment

12 AUDIO IN CH1/CH2/CH3/CH4 (audio channel 1/2/3/4 input selection) switches

Select the audio input signals to be recorded on audio channels 1, 2, 3 and 4.

FRONT: Audio input signals from the microphone connected to the MIC IN connector

REAR: Audio input signals from an audio device connected to the AUDIO IN CH-1/CH-2 connectors

WIRELESS: Audio input signals from the UHF portable tuner if it is installed

Left side and upper section

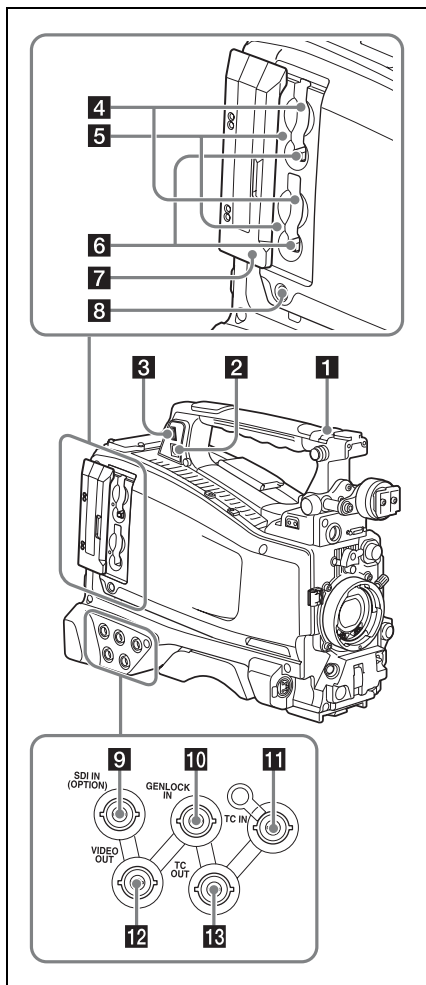

1 ASSIGNABLE 4/5 switches

You can assign the desired functions to these switches on OPERATION > Assignable SW in the setup menu (see page 156).

Off is assigned to these switches when the camcorder is shipped from the factory.

2 PC connector

Used to put this camcorder into USB connection mode and use it as an external storage device for a computer. When a computer without ExpressCard slot is connected to this connector, every memory card inserted in the camcorder is recognized as a drive for that computer.

3 External device connector

Connect an optional CBK-WA01 Wi-Fi Adapter or a USB flash drive.

When a CBK-WA01 is connected: Wireless LAN connection is available.

When a USB flash drive is connected:

Recording, saving and loading the following data are available.

- Recording of proxy data (see page 85)
- Loading of planning metadata (see page 87)
- Save and load setting data (see page 160)

Notes

- When you connect a CBK-WA01, install the optional CBK-UPG01 Hardware Upgrade Key.
- Use this connector only for connecting a CBK-WA01 or a USB flash drive. Do not connect and use a USB hub or similar products.

For details on how to use the CBK-WA01, refer to the Supplement supplied in the CD-ROM (labeled "Manuals for Solid-State Memory Camcorder").

4 SxS memory card slots

These two slots (A and B) can receive SxS memory cards or other recording media (see page 69).

5 ACCESS lamps

Indicate the state of slots A and B (see page 69). You can check whether the lamps are lit even when the slot cover is closed.

6 EJECT buttons

To remove the recording media from the slot, press the EJECT button to release the lock, then press the button once more. This makes the media come out of the slot partially (see page 70).

7 Slot cover

Slide to the left and right to open and close.

8 SLOT SELECT (SxS memory card select) button

When SxS memory cards are loaded in both card slots A and B, press this button to select the card you want to use (*see page 70*).

9 SDI IN (OPTION) (SDI input (optional)) connector (BNC type)

When the optional CBK-HD02 SDI/COMPOSITE Input and 50 Pin Interface is installed, the camcorder can record HDSDI or SDDSI signals input to this connector.

10 GENLOCK IN (genlock signal input) connector (BNC type)

This connector inputs a reference signal when the camcorder is to be genlocked or when timecode is to be synchronized with external equipment. Available reference signals vary depending on the current system frequency as shown in the following table.

System frequency	Available reference signals
1080/59.94i	1080/59.94i, 480/59.94i
1080/29.97P	1080/59.94i, 480/59.94i
1080/23.98P (PsF output)	1080/23.98PsF, 480/59.94i
1080/23.98P (Pulldown output)	1080/59.94i, 480/59.94i
720/59.94P	1080/59.94i, 720/59.94P, 480/59.94i
720/29.97P	1080/59.94i, 720/59.94P, 480/59.94i
720/23.98P	1080/59.94i, 720/59.94P, 480/59.94i
480/59.94i	1080/59.94i, 480/59.94i
480/29.97P	1080/59.94i, 480/59.94i
1080/50i	1080/50i, 576/50i
1080/25P	1080/50i, 576/50i
720/50P	1080/50i, 720/50P, 576/50i
720/25P	1080/50i, 720/50P, 576/50i
576/50i	1080/50i, 576/50i
576/25P	1080/50i, 576/50i

(Genlock for the camera module supports horizontal sync signals only.) Use MAINTENANCE >GENLOCK in the setup menu to adjust the genlock H-phase (phase of horizontal sync signal).

When the optional CBK-HD02 SDI/COMPOSITE Input and 50 Pin Interface is installed, the camcorder can record analog composite video signals input to this connector.

11 TC IN (timecode input) connector (BNC type)

To apply an external lock to the timecode of the camcorder, input the reference timecode.

For details, see "Setting the Timecode" (page 62).

12 VIDEO OUT connector (BNC type)

Outputs video signals for monitoring. The output signals can be selected either composite video or HD-Y depending on the setting of OPERATION >Input/Output >Output&i.LINK in the setup menu.

13 TC OUT (timecode output) connector (BNC type)

To lock the timecode of an external VTR to the timecode of this camcorder, connect this connector to the external VTR's timecode input connector.

Rear

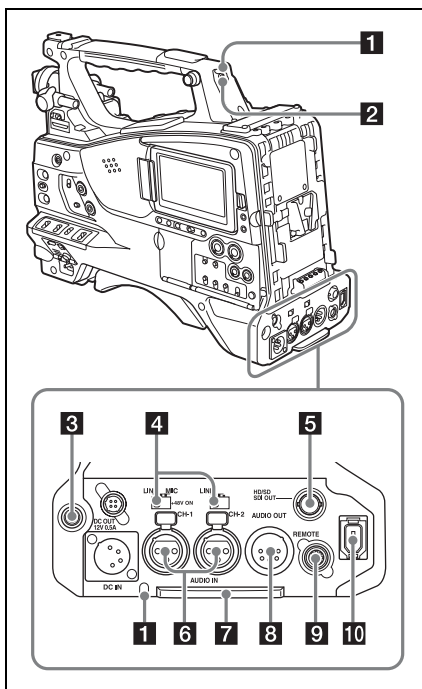

1 TALLY (back tally) indicators (red)

Light up during recording. They will not light if the TALLY switch is set to OFF. These indicators also flash to indicate warnings (see page 21). The tally indicator on the front of the viewfinder and the REC indication on the viewfinder screen light or flash in the same manner.

For details, see “Operation Warnings” (page 176).

2 TALLY switch

Set to ON to activate the TALLY indicator function.

3 EARPHONE jack (stereo, minijack)

You can monitor the E-E sound during recording and playback sound during playback. When an alarm is indicated, you can hear the alarm sound through the earphone. Plugging an earphone into the jack automatically cuts off the built-in speaker.

You can select monaural or stereo on MAINTENANCE >Audio in the setup menu.

4 AUDIO IN selectors

Select the audio source you connect to the AUDIO IN CH1/CH2 connectors.

LINE: When connecting a stereo amplifier or other external audio signal source

MIC: When connecting a microphone that does not require 48 V power supply

+48V: When connecting a microphone that requires 48 V power supply

5 HD/SD SDI OUT connector (BNC type)

Outputs an HDSDI or SDSDI signal (with embedded audio). The output from this connector can be turned on or off by OPERATION >Input/Output >SDI Output in the setup menu.

6 AUDIO IN CH-1/CH-2 (audio channel 1 and channel 2 input) connectors (XLR type, 3-pin, female)

These are audio input connectors for channels 1 and 2 to which you can connect audio equipment or a microphone.

7 Bottom cover

This is provided for protecting the cables connected to the connectors on the rear panel.

By loosening the screws which retain the cover to the bottom of the camcorder, you can adjust the position of the cover depending on the size and shape of the microphone or audio cable plugs.

After adjusting the position, tighten the screws to secure the cover.

8 AUDIO OUT connector (XLR type, 5-pin, male)

Outputs the audio signals recorded on audio channels 1 and 2 or audio channels 3 and 4. The audio signals are selected by the MONITOR switch.

9 REMOTE connector (8-pin)

Connect a remote control unit, which makes it possible to control the camcorder remotely.

Note

Before connecting/disconnecting the Remote Control Unit to/from the camcorder, be sure to turn off the camcorder POWER switch.

10 i.LINK (HDV/DV) connector (6-pin, IEEE1394 compliant, S400)**FAT**

When the recording mode is FAT, to input and output HDV/DV streams, connect to an HDV/DV device.

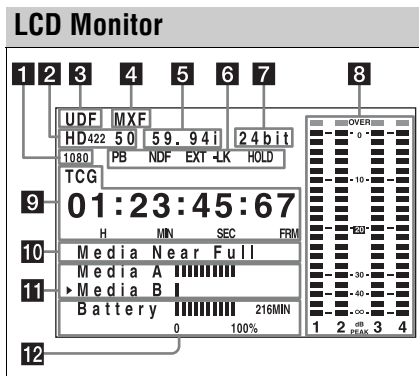
**1 Resolution**

Indicates the resolution of HD output video.

Indication	Resolution (horizontal × vertical)
1080	1080 lines (1920 × 1080)
720	720 lines (1280 × 720)

2 Recording format

Indicates the current recording format or the recording format of clip being currently played.

- UDF mode
 - HD422 50
 - HD420 HQ
 - IMX50
 - DVCAM
- FAT mode
 - HQ1920
 - HQ1440
 - HQ1280
 - SP1440
 - DVCAM

3 Recording mode

UDF: UDF mode

FAT: FAT mode

4 File format

MXF: When the recording mode is UDF

MP4: When the recording mode is FAT-HD mode

DV-AVI: When the recording mode is FAT-SD mode

5 System frequency

Indicates the system frequency of video being currently played or recorded.

59.94i
29.97P
23.98P
50i
25P
59.94P
50P

6 Status display

PB: Appears during play.

NDF: Appears when non-drop-frame timecode is selected.

EXT-LK: Appears when the internal timecode generator is locked to an external signal input to the TC IN (timecode input) connector.

HOLD: Appears when the operation mode of the internal timecode generator is set to R-RUN and stopped.

7 Audio format

Indicates the audio recording format or the audio format of clip being currently played.

Indication	Status	
	Recording mode	Recording format
16bit	FAT	Any format
	UDF	<ul style="list-style-type: none"> • HD420 HQ • DVCAM • IMX (Audio Length is set to 16 bit)
24bit	UDF	<ul style="list-style-type: none"> • HD422 50 • IMX (Audio Length is set to 24 bit)

8 Audio level indicators

Indicate the audio recording or play levels of channels 1 to 4.

9 Time counter display

Switches displays of time counter values, timecode, and user bits data, depending on the position of the DISPLAY switch.

Displays the type of data currently shown in the time counter, as follows.

TCG: Recorded timecode

TCR: Playback timecode

UBG: Recorded user bits

UBR: Playback user bits

CNT: Counter

CLK: Time display (when the PRESET/REGEN/CLOCK switch is set to CLOCK)

When the HOLD button is pressed to hold the timecode value, the timecode is displayed in the format shown below. When the HOLD button is pressed again to release the hold, the timecode is displayed in the normal format.

00 : 00 : 00 : 00

The three dots indicates that timecode is displayed in the hold mode.

10 Warning indicator area

Displays warnings when trouble with recording or moisture condensation occurs.

For details, see "Operation Warnings" on page 176.

You can also display the name of the next clip to be recorded (*see page 127*).

11 Remaining media capacity indicator

Shows bar segments indicating the remaining capacity of recording media in the slots.

12 Remaining battery capacity indicator

Shows bar segments indicating the remaining battery capacity.

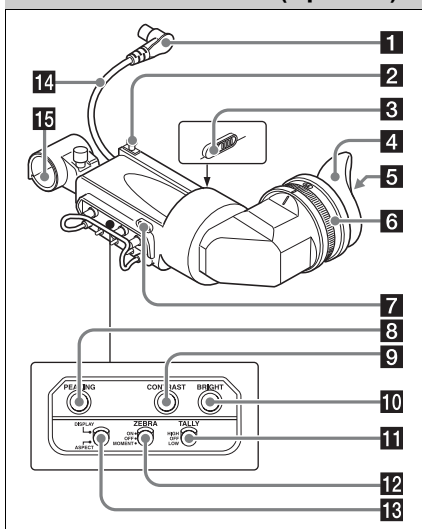
HDVF-20A Viewfinder (Optional)**1 Plug**

Connect to the VF connector (20-pin) on the camcorder.

2 Stopper

Prevents the viewfinder from coming off the camcorder when it is slid from side to side.

3 Camera operator tally indicator

Lights up while camcorder is recording. This indicator can be covered when not in use. This indicator also flashes to indicate warnings, in the same manner as the tally indicator and the recording/red tally indicators in the viewfinder.

4 Eyecup**5 Indicators and status display**

For details, see "Status Display on the Viewfinder Screen" on page 30.

6 Diopter adjustment ring

Allows for optimal focus adjustment.

7 Tally indicator

Lights up while camcorder is recording. Set the TALLY switch to OFF when not in use. The brightness can also be adjusted with the TALLY switch.

This indicator also flashes to indicate warnings, in the same manner as the camera operator tally indicator and the recording/red tally indicators in the viewfinder.

8 PEAKING control

Turning this control clockwise adjusts the picture sharpness, and makes focusing easier. This control has no effect on the output signals of the camcorder.

9 CONTRAST control

Adjusts the contrast of the screen. This control has no effect on the output signals of the camcorder.

10 BRIGHT control

Adjusts the brightness of the screen. This control has no effect on the output signals of the camcorder.

11 TALLY switch

Controls the tally indicator located on the front of the viewfinder.

HIGH: The tally indicator brightness is set to high.

OFF: The tally indicator is disabled.

LOW: The tally indicator brightness is set to low.

12 ZEBRA (zebra pattern) switch

Controls the zebra pattern display on the viewfinder screen as follows.

ON: A zebra pattern appears and stays.

OFF: The zebra pattern disappears.

MOMENT: A zebra pattern appears and stays for about five seconds.

13 DISPLAY/ASPECT switch

Turns the marker indication on and off, and switches between 4:3 and 16:9 aspect ratios for viewfinder screen display.

DISPLAY: When the marker indication is enabled with the camcorder, the marker indication on the viewfinder screen turns on and off every time you push the switch up to this position.

ASPECT: Each push of the switch down to this position toggles the mask display on and off.

(Make mask display settings using OPERATION >Marker >Aspect Mask in the setup menu (see page 119).)

14 Viewfinder cable

15 Microphone holder

CBK-VF01 Viewfinder (Optional)

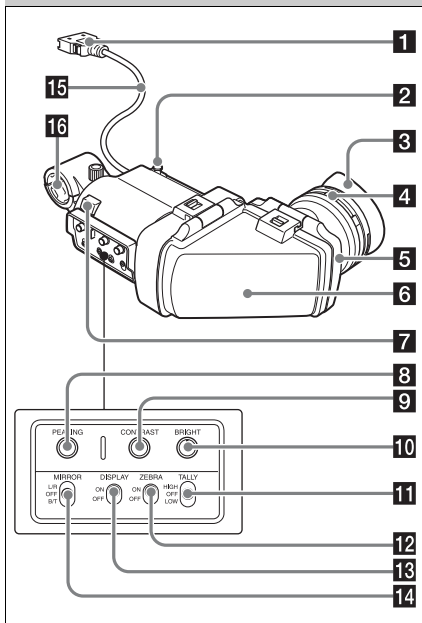

1 Plug

Connect to the VF connector (26-pin) on the camcorder.

2 Stopper

Prevents the viewfinder from coming off the camcorder when it is slid from side to side.

3 Eyecup

4 Diopter adjustment ring

Allows for optimal focus adjustment.

5 Eyepiece

You can raise this up when required by the situation.

6 Viewfinder barrel

You can raise this up or rotate when required by the situation.

7 Tally indicator

Lights up when recording is started by a press of the REC START button on this camcorder, the VTR button on the lens, or the VTR button on the remote control unit.

When an abnormality occurs, the tally indicator flashes to indicate a warning.

8 PEAKING control

Turning this control clockwise adjusts the picture sharpness, and makes focusing easier. This control has no effect on the output signals of the camcorder.

9 CONTRAST control

Adjusts the contrast of the screen. This control has no effect on the output signals of the camcorder.

10 BRIGHT control

Adjusts the brightness of the screen. This control has no effect on the output signals of the camcorder.

11 TALLY switch

Controls the tally indicator located on the front of the viewfinder.

HIGH: The tally indicator brightness is set to high.

OFF: The tally indicator is disabled.

LOW: The tally indicator brightness is set to low.

12 ZEBRA (zebra pattern) switch

Controls the zebra pattern display on the viewfinder screen as follows.

ON: Display a zebra pattern.

OFF: Do not display a zebra pattern.

13 DISPLAY switch

Turns the display of text information on and off.

ON: Display text information.

OFF: Do not display text information.

14 MIRROR switch

The image display on the monitor screen becomes reversed horizontally or vertically when the viewfinder barrel is raised up or rotated. Use this switch to control the image display in such situation.

L/R: Reverse the image horizontally.

OFF: Do not reverse the image.

B/T: Reverse the image vertically.

15 Viewfinder cable

16 Microphone holder

Status Display on the Viewfinder Screen

Indicators (HDVF-20A)

The following indicators are arranged above and below the screen of the HDVF-20A to show the current state and adjustments of the camcorder.

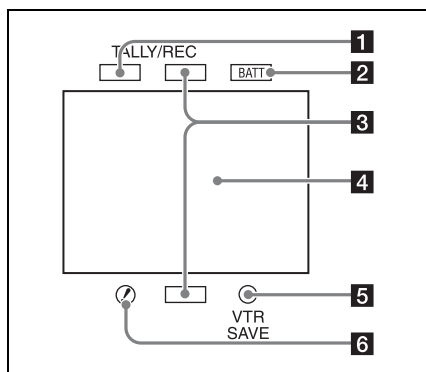

1 Green tally indicator

Lights when the camcorder is the following states.

- Picture Cache mode enabled
- Green tally signal received (when a camera adaptor is mounted on the camcorder and a camera extension unit is connected)
- Recording with MAINTENANCE >Camera Config >HD/SDI Remote I/F in the setup menu set to [G-Tally]

Flashes when the camcorder is the following states.

- Set to Interval Rec mode or the consecutive mode of Frame Rec mode (1 flash per second)
- Recording in Interval Rec mode or recording in the consecutive mode of Frame Rec mode (4 flashes per second)
- Set to the single-shot mode of Frame Rec mode, or recording in that mode (2 flashes per second)

2 BATT (battery) indicator

This indicator starts flashing when the battery connected to the camcorder is nearly exhausted, and stays lit when the battery is completely exhausted.

To prevent interruption during operation, replace the battery as soon as this indicator starts flashing.

The battery power level at which the indicator starts flashing can be set by MAINTENANCE >Battery in the setup menu. For details, see page 135.

3 Recording/red tally indicators

Light when the camcorder is the following states.

- Recording with the MAINTENANCE >Camera Config >HD/SDI Remote I/F menu item set to [R-Tally]
- Green tally signal or call signal received (when a camera adaptor is mounted on the camcorder and a camera extension unit is connected)

These indicators also flash to indicate warnings, in the same manner as the tally indicator and the camera operator tally indicator.

4 Viewfinder screen

See “Viewfinder screen display” (page 30).

5 VTR SAVE indicator

Do not function on this camcorder.

6 ! (warning) indicator

This indicator lights when any of the following conditions occurs with the corresponding item set to [On] by OPERATION >“!” LED in the setup menu.

- The gain is set to other than 0 dB.
- The SHUTTER selector is set to ON.
- The WHITE BAL switch is set to PRST.
- ATW is enabled.
- The lens extender is used.
- The reference value of auto iris adjustment is not the standard value.
- The FILTER selector is set to other than 1.

Viewfinder screen display

The viewfinder screen displays not only the video picture but also characters and messages indicating the camcorder settings and operating status, a center marker, a safety zone marker, etc. When the menu screen is not displayed and the DISPLAY switch is set to ON, the items for which an ON setting was made with

OPERATION >Super Impose in the setup menu or with related switches are displayed at the top and bottom of the screen.

Caution messages are indicated for three seconds when you carry out operations to change camcorder settings. Adjustment execution messages are indicated while adjustments proceed. When adjustments are finished, messages showing the results of adjustments appear for three seconds.

Not only these indications are displayed on the viewfinder screen, but a menu setting enables them to be output as video signals.

All items that can be displayed on the viewfinder screen are shown below.

Top of viewfinder screen

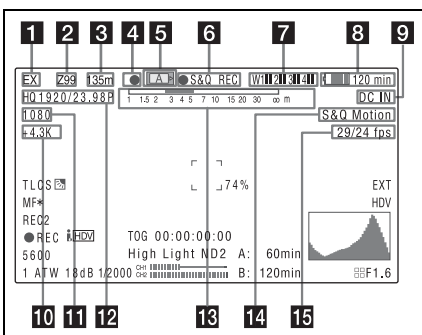

1 Extender settings

Indicates the setting of the digital extender function (when optional CBK-HD02 SDI/COMPOSITE Input and 50 Pin Interface is installed) of this camcorder and the setting of the lens extender.

EX: The lens extender is on.

08: The lens shrinker is on.

x2D: The digital extender function of this camcorder is on.

Ex2D: The lens extender and the digital extender function of this camcorder are both on.

Digital extender function can be turned on or off by an assignable switch to which Digital Extender is assigned.

Note

When slow & Quick motion is selected or the freeze mix function is used, the digital extender cannot be turned on. When the camcorder is in focus magnification (Focus Mag) mode, turning on the digital extender cancels the mode.

2 Zoom position (when the lens is mounted)

Indicates the zoom position of the zoom lens in the range from 0 to 99.

3 Focus position (when the serial lens is mounted)

Indicates the focus position as distance to the subject (in units of m).

4 Green tally

Lights when the camcorder is the following states.

- MAINTENANCE >Camera Config >HD-SDI Remote I/F is set to [G-Tally] in the setup menu and a recording control signal is output from the HD/SD SDI OUT connector.
- When the Picture Cache mode is enabled
- Green tally signal received (when a camera adaptor is mounted on the camcorder and a camera extension unit is connected)

5 Media status

Displays the name of the currently active media slot (A or B).

6 Special recording mode/operation status

Indicates the current special recording mode/operation status as follows.

Indication	Meaning
●REC	Recording in progress
STBY	When recording is on a break in Clip Continuous Rec mode or standby in other modes
CONT	Standby for next recording in Clip Continuous Rec mode
●CACHE	Standby in Picture Cache mode
●INT REC	Recording in progress in Interval Recording mode
●INT STBY	Standby for next recording in Interval Recording mode
INT STBY	Standby in Interval Recording mode
●FRM REC	Recording in progress in Frame Recording mode
●FRM STBY	Standby for next recording in Frame Recording mode
FRM STBY	Standby in Frame Recording mode
●S&Q REC	Recording in progress in Slow & Quick Motion mode

Indication	Meaning
S&Q STBY	Standby in Slow & Quick Motion mode
CALL (displayed in red)	Being called from a connected device
►REVIEW	During recording review

7 Wireless receiver reception level

When a wireless receiver is installed in the camcorder, “W” appears together with four segment reception level indicators for each of the channels (1 to 4) that can be used by the receiver. The indications are as follows.

In normal situation: The number of white segments indicates the strength of the signal level.

Muting (for an analog receiver) or error rate aggravation (for a digital receiver): The number of grey segments indicates the strength of the signal level.

Reception level over peak: “P” is displayed instead of the indicators. ¹⁾

Tuner battery is low: The channel number and indicator of the corresponding channel flash. ¹⁾

1) When an optional DWR-S01D is used

8 Battery remaining/voltage capacity

The following is displayed depending on the type of power source.

Type of power source	What is displayed
InfoLithium battery	Remaining battery capacity icon and remaining recording time
Anton Bauer battery	Remaining battery capacity (% indication)
Other type than above	Input voltage

9 External power input

Appears when power is supplied from an external power source connected to the DC IN connector.

10 Color temperature

Displays a color temperature calculated from the gain of R and B, in the range 1.5 K to 50.0 K (in steps of 0.1 K). The +/- signs may be displayed depending on the Offset White setting (*see page 124*).

No display: Offset White is OFF

+: The value of Offset White is greater than 3200K.

-: The value of Offset White is less than 3200K.

11 Number of system lines

Indicates the number of system lines (1080/720/576/480/486¹⁾) of video currently being recorded or played back.

1) In SD mode, when OPERATION >Format >Country is set to other than [PAL Area] in the setup menu.

In UDF mode: 486

In FAT mode: 480

In UDF mode, the system frequency is also displayed here.

12 Video format

Indicates the video format for recording (59.94i/29.97P/23.98P/50i/25P/59.94P/50P) or the video format of clip being currently played back (*see page 51*).

The video aspect ratio (16:9 or 4:3) can also be displayed when the recording format is set to IMX50 or DVCAM.

13 Depth of field indication (when the serial lens is mounted and when the CBK-VF01 is used)

Error/warning indication

A bar indicates the depth of field. The display unit is meters or feet, as selected by OPERATION >Display On/Off >Lens Info in the setup menu. An error or warning message is displayed here depending on the situation.

Under this area, you can also display the name of the next clip to be recorded (*see page 127*).

14 Special recording mode indication

The following is displayed when the camcorder is in a special recording mode.

- Frame Rec (Frame Recording mode)
- Interval Rec (Interval Recording mode)
- S&Q Motion (Slow & Quick Motion mode)

15 Special recording mode settings indication

Appears when the camcorder is in a special recording mode.

Bottom of viewfinder screen

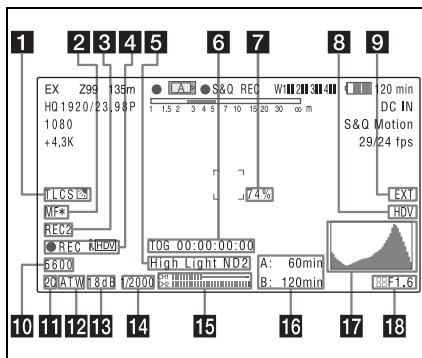
**1 TLCS iris control mode**

The following icons are displayed to indicate the video level control modes based on the Total Level Control System (TLCS).

Icon	TLCS control mode
	Backlight mode
	Standard mode
	Spotlight mode

2 Focus adjustment mode (when the auto focus lens is mounted)

Indicates the current focus adjustment mode of the camcorder.

- AF (Auto Focus mode)
- MF (Manual Focus mode)
- MF* (Manual Focus mode when the MF Assist function is on)
- Full MF (Full Manual Focus mode)

3 External device control

“REC2” is displayed when MAINTENANCE >Camera Config >HD-SDI Remote I/F is set to [Chara] in the setup menu and a recording control signal is output from the HD/SD SDI OUT connector.

4 Operation status of connected i.LINK device

The operating format (HDV or DV) and operation status of that device are indicated as follows.

Indication	Meaning
●REC	HDV recording in progress
STBY	Standby for HDV recording

Indication	Meaning
●REC	DV recording in progress
STBY	Standby for DV recording

5 Video level indication

An indication is displayed together with an appropriate ND filter position number when the light level of the subject is too high or too low.

6 Timecode**Caution message**

Indicates the elapsed recording/playback time, timecode, user bits data or other information selected by the DISPLAY switch (*see page 22*). Also indicates a caution message when caution is required such as when you try to change settings.

7 Brightness level (when the CBK-VF01 is used)

Indicates the average brightness level (%) of the detection area.

8 External input source

Indicates the type of external input signal (HDV) to be recorded.

9 Recording of external input

Indicates “EXT” when an external input is recorded.

10 Electric color temperature filter

Appears when the CC 5600K function is set to on.

11 Filter position

Indicates the currently selected ND filter position number. (*see page 17*).

When ELECTRICAL CC is assigned to an assignable switch, the electrical filter position (A/B/C/D) appears to the right of the ND filter position (1 to 4), as shown on the previous page.

12 White balance memory

Indicates the currently selected white balance automatic adjustment memory.

ATW: ATW (Auto Tracing White Balance) mode

W:A: Memory A mode

W:B: Memory B mode

W:P: Preset mode

3200: When the assignable switch to which Color Temp SW 3200K has been assigned is on

4300: When the assignable switch to which Color Temp SW 4300K has been assigned is on

5600: When the assignable switch to which Color Temp SW 5600K has been assigned is on

6300: When the assignable switch to which Color Temp SW 6300K has been assigned is on

13 Gain value

Indicates the gain value (in dB) of the video amplifier, as set by the GAIN selector.

14 Shutter

Indicates the shutter speed or the shutter mode.

For details, see “Setting the Electronic Shutter” (page 57).

15 Audio level meters

Indicate the audio levels of channel 1 and channel 2.

16 Remaining media capacity

The available time for recording with the current video format (recording bit rate) is calculated according to the remaining space of each media and indicated in time units of minutes. A lock icon appears if the media is write-protected.







17 Histogram (when the CBK-VF01 is used)

Shows a pixel distribution of video luminance (in HD mode only).

18 Iris position (when the lens is mounted)

Indicates the iris position and the setting for iris override (reference value for the lens iris) (see page 59).

The iris override setting is indicated by four segments indicator as follows.

Reference value	Indicator	
+0.25		Lower left segment is lit in grey.
+0.5		Left two segments are lit in grey.
+0.75		Left two segments and lower right segment are lit in grey.
+1		All segments are lit in grey.
-0.25		Lower left segment is lit in white.
-0.5		Left two segments are lit in white.
-0.75		Left two segments and lower right segment are lit in white.

Reference value	Indicator	
-1		All segments are lit in white.

Preparing a Power Supply

For safety, use only the Sony battery packs and AC adaptors listed below.

- BP-GL95/GL65/L60S/L80S Lithium-ion Battery Pack
- AC power using the AC-DN2B/DN10 AC Adaptor

CAUTION

Danger of explosion if battery is incorrectly replaced. Replace only with the same or equivalent type recommended by the manufacturer.

When you dispose of the battery, you must obey the law in the relative area or country.

ATTENTION

Il y a danger d'explosion s'il y a remplacement incorrect de la batterie. Remplacer uniquement avec une batterie du même type ou d'un type équivalent recommandé par le constructeur.

Lorsque vous mettez la batterie au rebut, vous devez respecter la législation en vigueur dans le pays ou la région où vous vous trouvez.

VORSICHT

Explosionsgefahr bei Verwendung falscher Batterien. Batterien nur durch den vom Hersteller empfohlenen oder einen gleichwertigen Typ ersetzen.

Wenn Sie die Batterie entsorgen, müssen Sie die Gesetze der jeweiligen Region und des jeweiligen Landes befolgen.

Using a Battery Pack

When a BP-GL95/GL65/L60S/L80S Battery Pack is used, the camcorder will operate continuously for the time shown below.

Model name	Operating time
BP-GL95	Approx. 180 minutes
BP-GL65	Approx. 120 minutes
BP-L60S	Approx. 110 minutes
BP-L80S	Approx. 145 minutes

WARNING

Batteries shall not be exposed to excessive heat such as sunshine, fire or the like.

AVERTISSEMENT

N'exposez pas les batteries à une chaleur excessive, au soleil ou près d'un feu par exemple.

WARNUNG

Akkus dürfen keinesfalls übermäßiger Wärmeeinwirkung ausgesetzt werden, wie z.B. Sonneneinstrahlung, Feuer o. ä.

Note

The battery pack operating time depends on the frequency of use of the battery pack, and the ambient temperature when used.

Before use, charge the battery pack with a charger suitable for each battery.

For details on the battery charging procedure, refer to the battery charger operation manual.

Note on using the battery pack

A warm battery pack may not be able to be fully recharged.

To attach the battery pack

- 1 Press the battery pack against the back of the camcorder, aligning the line on the side of the battery pack with the matching line on the camcorder.**

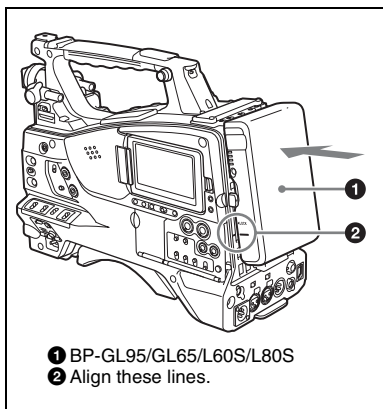

- 2 Slide the battery pack down until its “LOCK” arrow points at the matching line on the camcorder.

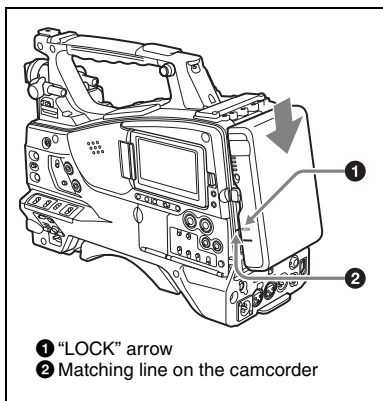

Note

If the battery pack is not attached correctly, the terminal may be damaged.

To detach the battery pack

Holding the release button in, pull the battery pack up.

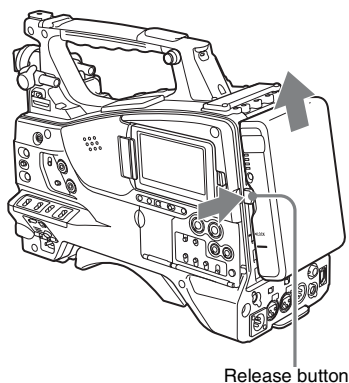

Notes

- During recording and playback (while the ACCESS lamp on the right-side panel is lit in blue and the ACCESS lamp in the card slot section is lit in orange), be careful never to remove the battery pack.
- Make sure to power the camcorder off before replacing the battery pack.

Using AC Power

Mount an AC-DN2B/DN10 on the camcorder in the same way as a battery pack, then connect to the AC power supply.

The AC-DN2B/DN10 can supply up to 100 W of power.

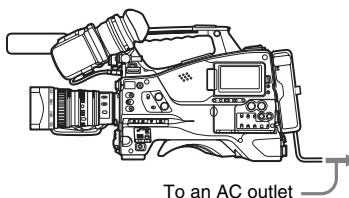

Attaching the Viewfinder

CAUTION

When the viewfinder is attached, do not leave the camcorder with the eyepiece facing the sun. Direct sunlight can enter through the eyepiece, be focused in the viewfinder and cause fire.

Note

The viewfinder is supplied separately.

The following procedure is an example for attaching the HDVF-20A.

For procedures for attaching other viewfinders, refer to a manual supplied with each viewfinder.

Attaching the Viewfinder

Note

When attaching the viewfinder, make notes of the following points.

- Be sure to power off the camcorder before coupling the viewfinder connector to the camcorder's VF connector (20-pin). If you make this connection when the camcorder power is on, the viewfinder may not function properly.
- Couple the viewfinder connector firmly to the camcorder's VF connector. If the coupling is loose, noise may appear on the video or the tally light may not operate properly.

For more information about the connection of the viewfinder and camcorder, contact a Sony service representative.

- 1 ① Loosen the viewfinder left-to-right positioning ring, ② attach the viewfinder to the viewfinder fitting shoe, and ③ tighten the viewfinder left-to-right positioning ring.

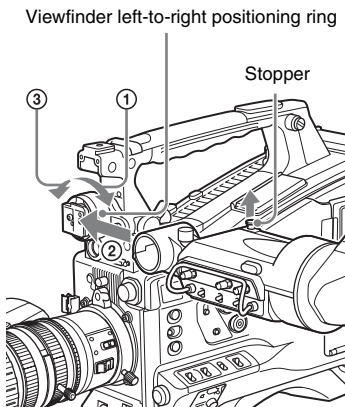

- 2 Couple the viewfinder connector to the VF connector (20-pin).

VF connector (20-pin)

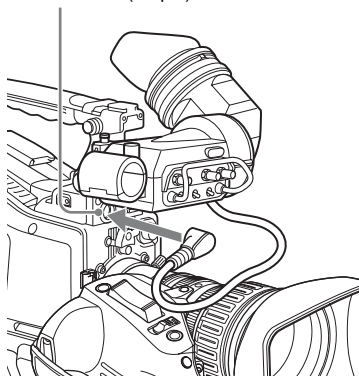

Detaching the viewfinder

You can carry out this by following the attaching procedure in reverse order, but there is an additional action to take: when detaching the viewfinder from the fitting shoe, pull up the stopper.

Adjusting the Viewfinder Position

To adjust the viewfinder left-right position, loosen the left-right positioning ring, and to adjust the front-back position, loosen the front-to-back positioning knob.

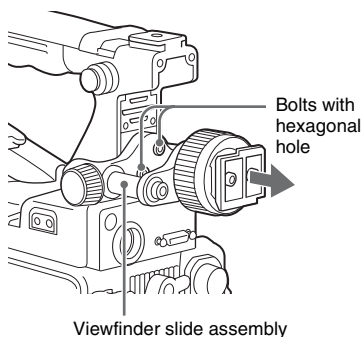
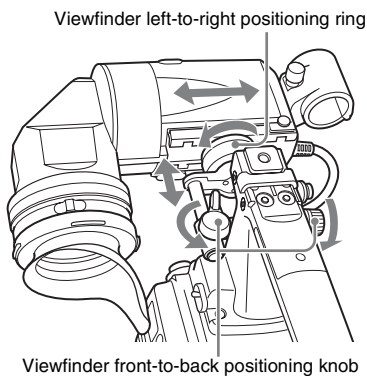

Using the BKW-401 Viewfinder Rotation Bracket

By fitting an optional BKW-401 Viewfinder Rotation Bracket, you can rotate the viewfinder out of the way so that your right leg does not hit the viewfinder while you are carrying the camcorder.

- 1 Loosen the front-to-back viewfinder positioning levers and the front-to-back viewfinder positioning knobs, and then pull the viewfinder slide assembly forward.

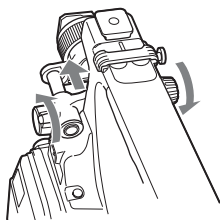

- 2 Using a 2.5 mm diameter hexagonal wrench, detach the viewfinder slide assembly.

- 3 Attach the BKW-401 with the supplied bolts.

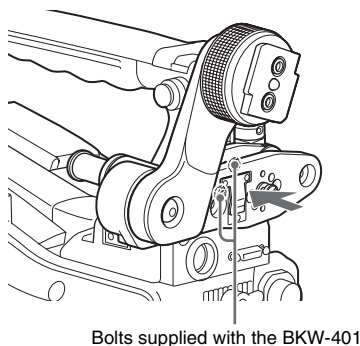

- 4 Adjust the front-to-back position so that the arm of the BKW-401 does not touch the handle when it is raised.**

Adjust position so that arm does not touch handle

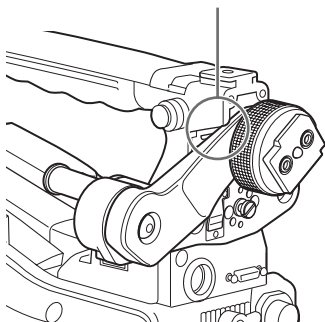

Detaching the Eyepiece

Removing the eyepiece gives a clearer view of the screen from further away. It is also easy to remove dust from the viewfinder screen and mirror when the eyepiece is detached.

- 1 Turn the eyepiece locking ring fully counterclockwise, to align the red marks on the locking ring and the viewfinder barrel.**

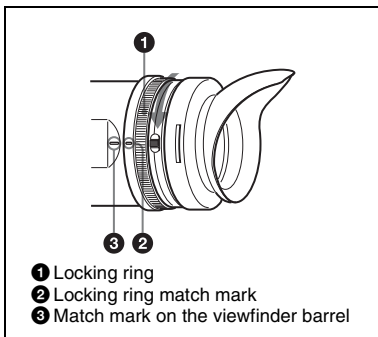

- 2 Detach the eyepiece.**

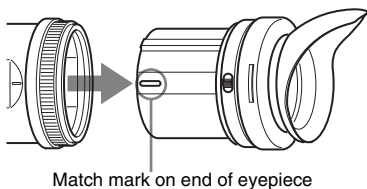

To reattaching the eyepiece

- 1 Align the red marks on the eyepiece locking ring and the viewfinder barrel.**
- 2 Align the red mark on the end of the eyepiece end with the red marks on the eyepiece locking ring and the viewfinder barrel. Then insert the eyepiece into the viewfinder barrel.**
- 3 Turn the eyepiece locking ring clockwise until its "LOCK" arrow points at the red mark on the viewfinder barrel.**

When the eyecup is worn out, replace it with a new one.

For details of a replacement eyecup, contact a Sony service representative.

Adjusting the Viewfinder Focus and Screen

To adjust the viewfinder focus

Turn the diopter adjustment ring until the viewfinder image is sharpest.

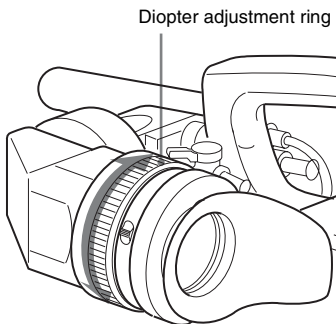

To adjust the viewfinder screen

Adjust the brightness, contrast, and peaking of the viewfinder screen with the controls shown below.

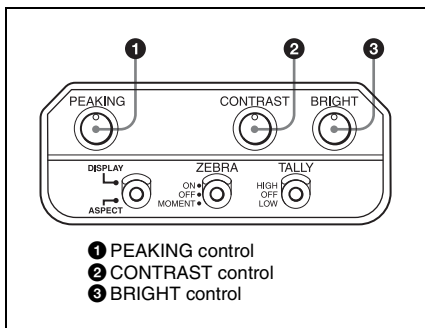

Setting the Area of Use

When using the camcorder for the first time

The area of use is not factory preset. Before using the camcorder, you need to set this item. (You cannot use the camcorder without setting this item.)

To set the area of use

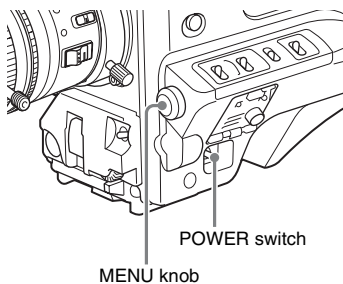

1 Set the POWER switch to the ON position.

The screen for setting the area of use appears in the viewfinder.



2 Press the MENU knob.

The settings for selectable areas of use are displayed.

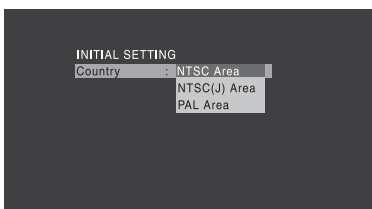

3 Turn the MENU knob to select the desired area of use.

Setting	Area of use
NTSC Area	NTSC area (for areas other than Japan) ^{a)}
NTSC(J) Area	NTSC area (Japan) ^{b)}
PAL Area	PAL area ^{c)}

- a) The composite signal output from this camcorder is an NTSC signal with a black setup (7.5 IRE). The system frequency is 59.94i.
- b) The composite signal output from this camcorder is an NTSC signal with no black setup. The system frequency is 59.94i.
- c) The composite signal output from this camcorder is a PAL signal. The system frequency is 50i.

4 Set the following items.

- Time Zone
- Date/Time

See “Basic Setup Menu Operations” (page 109).

5 Turn the MENU knob to select “Finish”, then press the MENU knob.

The camcorder is now ready for use.

Setting the Date/Time of the Internal Clock

You can set or change the date and time of the internal clock. The date and time set are reflected in the timecode.

For menu operations, see “Basic Setup Menu Operations” (page 109).

1 Select MAINTENANCE >Clock Set >Date/Time in the setup menu.

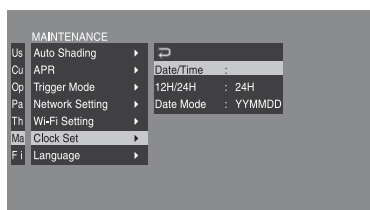

2 Press the MENU knob.

The Date/Time setting window appears.

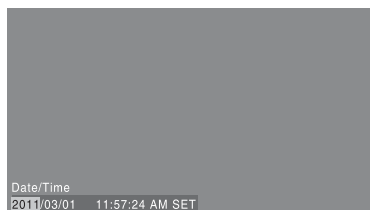

3 Turn the MENU knob to display the desired value, and press the knob.

The selection shifts to the next item on the right.

4 To continue the remaining settings, repeat step 3.

5 Making sure that “SET” is selected, press the MENU knob.

The internal clock is set with the date and time set in steps 3 and 4.

To cancel the setting

Before executing step 5, push the MENU CANCEL/PRST/ESCAPE switch up to the CANCEL/PRST side.

Mounting and Adjusting the Lens

Note

Always power the camcorder off before mounting or removing a lens.

For information about using the lens, refer to the operation manual for the lens.

Note

The lens is supplied separately.

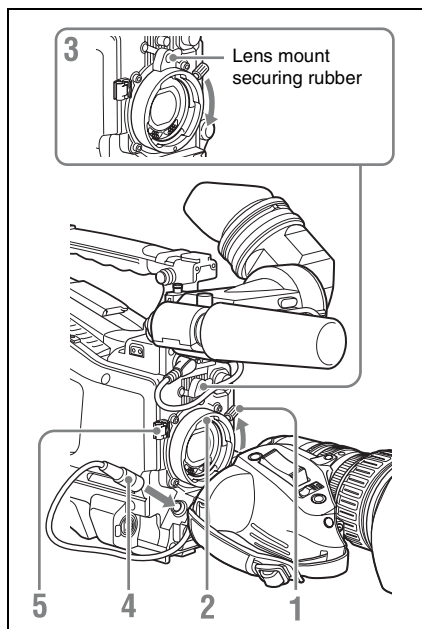

- 1** Push the lens locking lever up and remove the lens mount cap from the lens mount.
- 2** Align the center pin on the lens with the center slot in the lens mount, and insert the lens into the mount.
- 3** Holding the lens in place, push the lens locking lever down to lock the lens.

Caution

If the lens is not firmly locked, it may come off while the camcorder is being used. This could cause a serious accident. Make sure the lens is firmly locked. It is recommended that the lens mount securing rubber be put on the lens locking lever as illustrated above.

- 4** Connect the lens cable to the **LENS connector**.
- 5** Secure the lens cable with the **cable clamps**.

If you have attached an aberration correction lens

The aberration correction function is activated automatically. Starting the camcorder with an aberration correction lens may require more time than normally because of data loading at start-up. Contact a Sony service representative for information about aberration correction lenses.

Adjusting the Flange Focal Length

If the lens does not stay in focus properly as you zoom from telephoto to wide angle, adjust the flange focal length (the distance from the plane of the lens mounting flange to the imaging plane). Make this adjustment just one time after mounting or changing the lens.

When carrying out the adjustment, use a flange focal length adjustment chart as the subject.

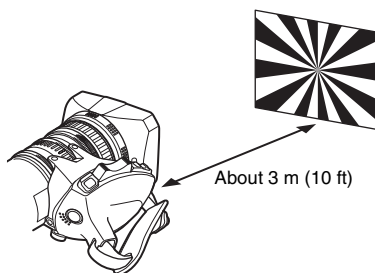

Notes

- If you use a subject with insufficient contrast, or move the camcorder or subject during adjustment, this will cause an adjustment error.
- Place the subject (the flange focal length adjustment chart) so that it appears at the center of the screen at the telephoto end. Arrange so that no nearby object (no object closer to the camera than the chart) enters the screen at the wide-angle end.

Carrying out the adjustment

- 1 Set the iris to manual.
- 2 Open the iris, position the supplied flange focal length adjustment chart approximately 3 meters (10 ft) away from the camcorder, and arrange the lighting to obtain a satisfactory video output.
- 3 Loosen the fixing screws on the F.f or F.B ring (flange focal length adjustment ring).
- 4 Use manual or power zoom to set the lens to telephoto.
- 5 Point the camcorder at the chart by turning the focus ring and focus on it.
- 6 Set the zoom ring to wide angle.
- 7 Turn the F.f or F.B ring until the chart is in focus, being careful not to disturb the focus ring.
- 8 Repeat steps 4 to 7 until the chart stays in focus all the way from wide angle to telephoto.
- 9 Tighten the F.f or F.B ring fixing screws.

Preparing the Audio Input System

Connecting a Microphone to the MIC IN Connector

You can attach the optional ECM-680S stereo microphone to the microphone holder of the viewfinder (optional).

The following procedure is an example for attaching a microphone holder to the HDVF-20A.

For procedures for attaching a microphone holder to other viewfinders, refer to a manual supplied with each viewfinder.

- 1 Loosen the screw and open the microphone holder clamp.

Microphone holder clamp

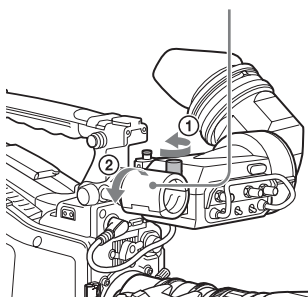

- 2 Place the microphone in the microphone holder.

- ① Wind the microphone spacer around the microphone, while peeling off the protective sheets on both sides of the microphone spacer.
- ② Place the microphone in the holder so that "UP" is at the top.
- ③ Close the microphone holder.
- ④ Tighten the screw.

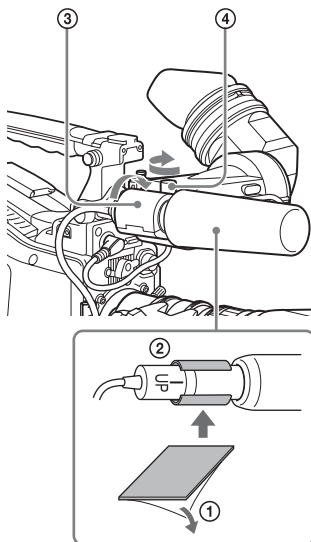

On how to perform this operation, refer to the operation manual for the microphone.

- 3 Plug the microphone cable into the MIC IN connector, then set the AUDIO IN switch for the channel on which you want to record the audio from this microphone to FRONT.**

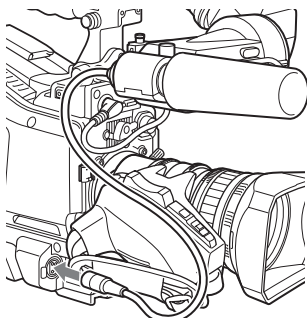

- 4 Secure the microphone cable with the cable clamp.**

Connecting Microphones to the AUDIO IN Connectors

You can connect up to two monaural microphones to the AUDIO IN CH-1/CH-2 connectors, using an optional CAC-12 Microphone Holder.

The following is the procedure for attaching an electret condenser microphone such as the ECM-674/678.

On how to attach the CAC-12, refer to the operation manual for the CAC-12.

1 Attach the electret condenser microphone.

- ① Loosen the ball joint lock lever.
- ② Wind the microphone spacer (sheet type, supplied with the microphone) around the protective sheets on both sides of the microphone spacer.
- ③ Place the microphone in the holder so that “UP” is at the top.
- ④ Close the microphone holder.
- ⑤ Tighten the screw.
- ⑥ Position so that the microphone does not interfere with the viewfinder and tighten the ball joint lock lever.

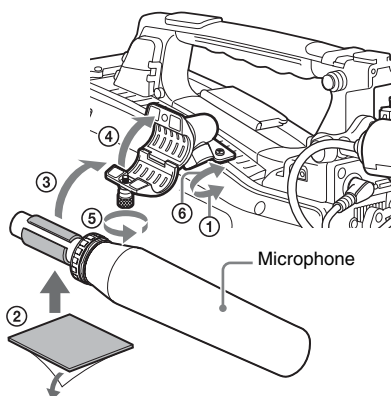

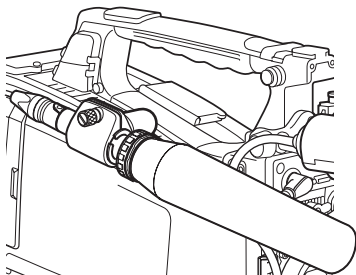

2 Connect the microphone cable to the AUDIO IN CH-1 or CH-2 connector.

3 Set the switches as follows.

- Set the AUDIO IN selectors indicated below, depending on the power supply type of the microphone.

Internal power supply: MIC

External power supply: +48V

- Set the AUDIO IN CH1/CH2 switch for the channel to which the microphone is connected to REAR.

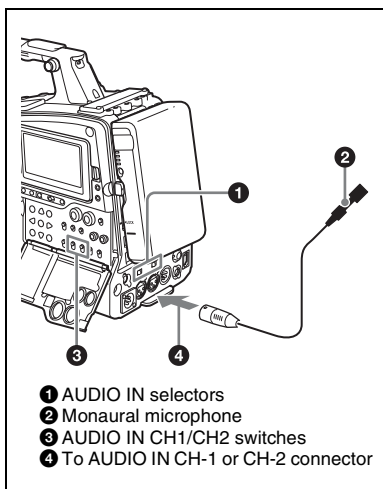

- 1 AUDIO IN selectors
- 2 Monaural microphone
- 3 AUDIO IN CH1/CH2 switches
- 4 To AUDIO IN CH-1 or CH-2 connector

4 Switch the input level to match the sensitivity of the microphone used.

Switch the input level by changing the setting of MAINTENANCE > Audio > Rear MIC CH1/CH2 Ref in the setup menu (factory default setting is -60 dB). *For details, see page 137.*

Notes

- If the input level on the camcorder is not at an appropriate setting for the microphone sensitivity, loud sounds may be distorted, and the signal-to-noise ratio may be affected.
- In order for the AUDIO IN CH-1 and CH-2 connectors on the camcorder to be able to provide a phantom 48 V power supply, female XLR connectors (3-pin) are fitted. If the microphone cable has a female connector, use an adaptor.
- When you detach a CAC-12 Microphone Holder once you have attached to the camcorder, be careful not to lose the two screws fixing the CAC-12 (in step 1). After detaching the CAC-12, be sure to put the two screws back into their original places.

Attaching a UHF Portable Tuner (for a UHF Wireless Microphone System)

To use a Sony UHF wireless microphone system, power the camcorder off and then fit one of the following UHF portable tuners.

- DWR-S01D Digital Wireless Receiver
- WRR-855S UHF Synthesized Tuner Unit
- WRR-860A/861/862 UHF Synthesized Diversity Tuner

For details of these units, refer to the operation manuals for them.

Note

The optional WRR Mount Bracket (service part number: A-8278-057-B) is required to fit the WRR-862.

For details, contact your vendor or a Sony service representative

To fit the DWR-S01D or WRR-855S

- Remove the four fixing screws holding the cover of the portable tuner/receiver housing slot located in the rear of the camcorder, to remove the cover.

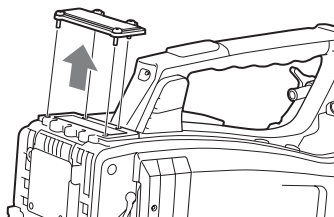

- 2** Insert the DWR-S01D or WRR-855S into the housing slot, and fasten the four fixing screws.

DWR-S01D or WRR-855S

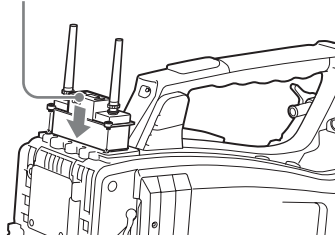

- 3** Set the AUDIO IN selector for the channel to which you want to input audio signal to WIRELESS (see page 23).

To fit the WRR-862 (when using a BP-GL65/GL95/L60S/L80S Battery Pack)

- 1** Attach the WRR tuner fitting (not supplied; service part number: A-8278-057-B) to the back of the camcorder.

- ① Use a Phillips type screwdriver to tighten the four screws placed in the tuner fitting. For three of these screws, insert the screwdriver through the corresponding hole and tighten the screw.

Note

Make sure that all four screws are fully tightened.

- ② Loosen the adjustment screws on the tuner fitting.
 ③ Adjust the tuner fitting position for a BP-GL65/GL95/L60S/L80S Battery Pack to be attached, and tighten the adjustment screws to fix its position.
 ④ Attach the mount plate supplied with the WRR-862.

About the WRR tuner fitting (service part number: A-8278-057-B), contact a Sony service or sales representative.

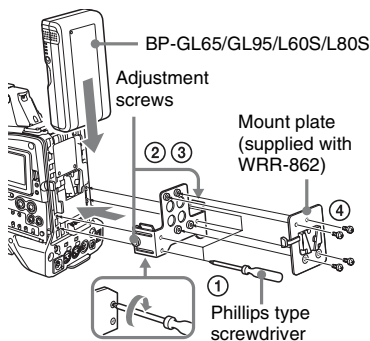

- 2** Attach the battery pack.

On how to attach the battery pack, see "To attach the battery pack" on page 35.

- 3** Mount the tuner on the WRR tuner fitting.

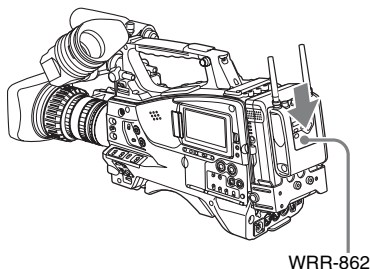

- 4** Connect the tuner power cord to the DC OUT connector of the camcorder, and the audio output cable to the AUDIO IN CH-1 or CH-2 connector.

- 5** Set the switches as follows.

- Set the AUDIO IN selector for the channel to which the audio output cable is attached to MIC.
- Set the AUDIO IN CH1/CH2/CH3/CH4 switch for the channel to which the audio output cable is connected to REAR. If the XLR connection automatic detection function is on, the input signal for audio recording is selected automatically, and therefore this setting is not required.

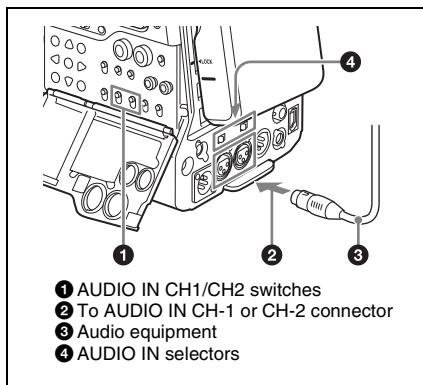
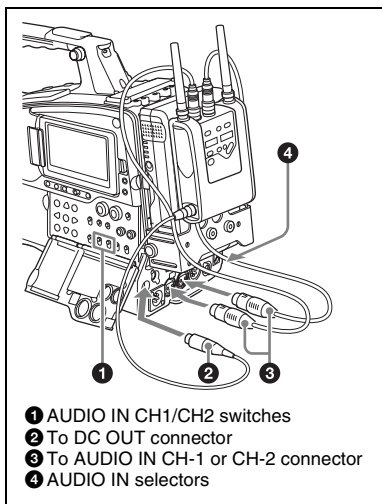

Connecting Line Input Audio Equipment

Connect the audio output connector of the audio equipment that supplies the line input signal to the AUDIO IN CH-1 or CH-2 connector.

Switch settings

Set the AUDIO IN selector for the channel to which the audio signal source is connected to LINE.

Selecting the audio inputs to be recorded

- With the XLR connection automatic detection function being off (the factory default setting): A signal must be selected for audio recording by setting the AUDIO IN CH1 or CH2 switch to REAR depending on which of the AUDIO IN CH-1 and CH-2 connectors is used for connecting the external audio equipment.
- With the XLR connection automatic detection function being on: When a cable is connected to the AUDIO IN CH-1 or CH-2 connector, the input from that connector is automatically selected for audio recording, regardless of the setting of the AUDIO IN CH1 or CH2 switch.

The XLR connection automatic detection function can be switched on or off by MAINTENANCE >Audio >Rear XLR Auto in the setup menu.

Tripod Mounting

- 1 Attach the optional VCT-14/U14 Tripod Adaptor to the tripod.

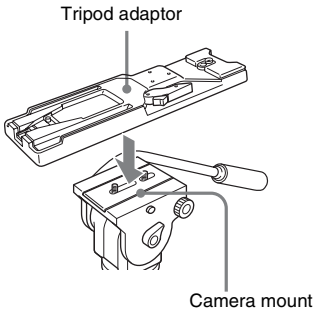

- 2 Mount the camcorder on the tripod adaptor.

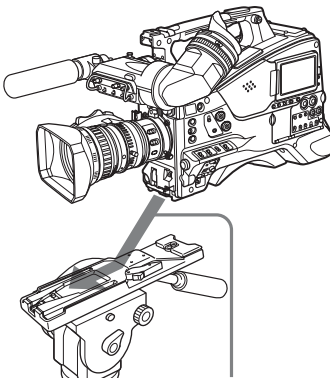

Slide the camcorder forward along the groove in the adaptor until it clicks.

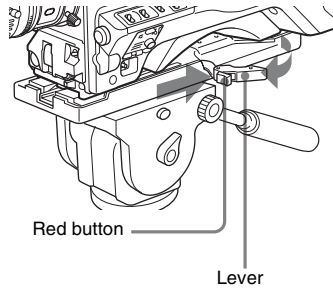

Note

The tripod adaptor pin may remain in the engaged position even after the camcorder is removed. If this happens, press the red button and move the lever as shown above until the pin returns to the stowed position. If the pin remains in the engaged position, you will not be able to mount the camcorder on the tripod adaptor.

To remove the camcorder from the tripod adaptor

Hold down the red button and pull the lever in the direction of the arrow.

Connecting a Video Light

With this camcorder, you can use the Anton Bauer Ultralight 2 or equivalent video light (powered by 12 V with maximum power consumption of 50 W).

- If you connect the video light to the LIGHT connector on the camcorder and set the LIGHT switch to AUTO, you can turn the light on and off automatically as you start and stop recording on this camcorder.
- The output of the LIGHT connector on the camcorder is controlled to 12 V even when the camcorder is supplied with over 12 V power (through the DC IN connector or battery pack). The brightness or color temperature of the light will not change according to voltage increase.

Notes

- Do not use a video light with power consumption of over 50 W.
- The brightness or color temperature of the light will change when the voltage (supplied through the DC IN connector or from the battery pack) is under 12 V.

To attach the video light

Fit the video light to the accessory fitting shoe on the camcorder grip, and connect the video light cable to the LIGHT connector.

Note

The accessory fitting shoe on the camcorder is of the $\frac{1}{4}$ -inch tapped hole type. If you want to replace this with a slide-type shoe, use the supplied cold shoe kit. On how to fit the cold shoe kit, refer to "Using an External Hard Disk" in the Supplement supplied in the CD-ROM (labeled "Manuals for Solid-State Memory Camcorder").

Using the Shoulder Strap

To attach the shoulder strap

1 Fit one of the clips to a shoulder strap fitting.

Pull up the strap to lock the fitting.

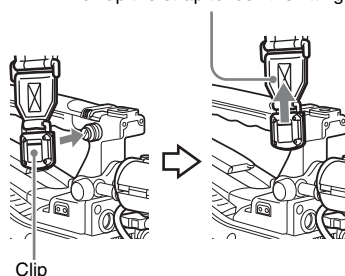

2 Fit the other clip to the shoulder strap fitting on the other side of the grip in the same way as in step 1.

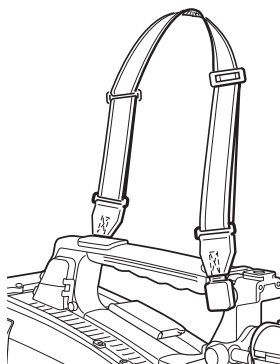

To remove the shoulder strap

Press here and pull in the direction shown by the arrow to release.

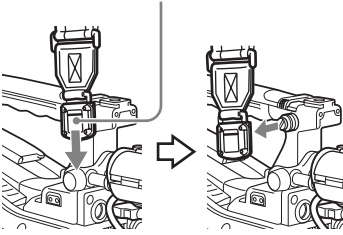

Adjusting the Shoulder Pad Position

You can slide the shoulder pad back and forth within a 40 mm range. This adjustment helps you get the best balance for shooting with the camcorder on your shoulder.

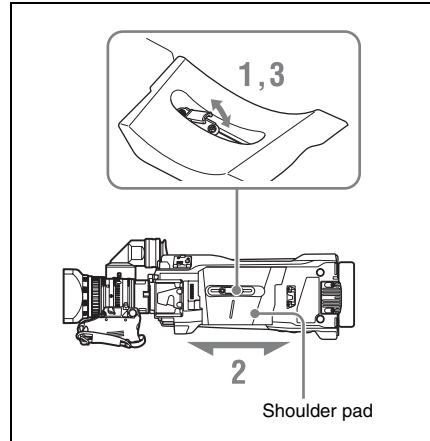

- 1** Raise the lever in the center of the shoulder pad to unlock the shoulder pad.
- 2** Slide the shoulder pad backward or forward until it is in the most convenient position.
- 3** Bring down the lever to lock the shoulder pad in the selected position.

For menu operations, see “Basic Setup Menu Operations” (page 109).

Setting the Video Format

The following recording formats can be selected for different combinations of video resolution and system frequency.

In UDF mode

UDF

OPERATION >Format menu settings				Video format (recording	Frame size	
HD/SD	HD System Line	Rec Format	System Frequency ^{a)}	format/system frequency)		
HD	1080	HD422 50	59.94i	HD422 1920/59.94i	1920×1080	
			50i	HD422 1920/50i		
			29.97P	HD422 1920/29.97P		
			25P	HD422 1920/25P		
		23.98P	HD422 1920/23.98P			
		HD420 HQ	59.94i	HQ 1440/59.94i		1440×1080
			50i	HQ 1440/50i		
			29.97P	HQ 1440/29.97P		
	25P		HQ 1440/25P			
	720	HD422 50	59.94P	HD422 1280/59.94P	1280×720	
			50P	HD422 1280/50P		
			29.97P	HD422 1280/29.97P		
			25P	HD422 1280/25P		
		23.98P	HD422 1280/23.98P			
		HD420 HQ	59.94P	HQ 1280/59.94P		
			50P	HQ 1280/50P		
23.98P ^{b)}			HQ 1280/23.98P			
SD	—	IMX50 ^{c)}	59.94i	IMX50/59.94i	720×486	
			50i	IMX50/50i	720×576	
			29.97P ^{d)}	IMX50/29.97P	720×486	
			25P ^{d)}	IMX50/25P	720×576	
	DVCAM ^{c)}	—	DVCAM ^{c)}	59.94i	DVCAM/59.94i	720×480
				50i	DVCAM/50i	720×576
				29.97P ^{d)}	DVCAM/29.97P	720×480
				25P ^{d)}	DVCAM/25P	720×576

a) **59.94i/29.97P/59.94P/23.98P:** When OPERATION >Format >Country in the setup menu is set to [NTSC Area] or [NTSC(J) Area]

50i/25P/50P: When OPERATION >Format >Country in the setup menu is set to [PAL Area]

b) 59.94i after 2-3 pulldown is recorded

c) When the optional CBK-MD01 is installed

d) Converted to PsF and recorded

In FAT mode

FAT

OPERATION >Format menu settings				Video format (recording format/system frequency)	Frame size	
HD/SD	HD System Line	Rec Format	System Frequency ^{a)}			
HD	1080	HQ 1920	59.94i	HQ 1920/59.94i	1920×1080	
			50i	HQ 1920/50i		
			29.97P	HQ 1920/29.97P		
			25P	HQ 1920/25P		
			23.98P	HQ 1920/23.98P		
		HQ 1440	59.94i	HQ 1440/59.94i		1440×1080
			50i	HQ 1440/50i		
			29.97P	HQ 1440/29.97P		
	25P		HQ 1440/25P			
	23.98P		HQ 1440/23.98P			
	SP 1440	59.94i	SP 1440/59.94i			
		50i	SP 1440/50i			
		23.98P ^{b)}	SP 1440/23.98P			
	720	HQ 1280	59.94P	HQ 1280/59.94P	1280×720	
			50P	HQ 1280/50P		
			29.97P	HQ 1280/29.97P		
25P			HQ 1280/25P			
23.98P			HQ 1280/23.98P			
SD	—	DVCAM ^{c)}	59.94i	DVCAM/59.94i	720×480	
			50i	DVCAM/50i	720×576	
			29.97P ^{d)}	DVCAM/29.97P	720×480	
			25P ^{d)}	DVCAM/25P	720×576	

a) **59.94i/29.97P/59.94P/23.98P:** When OPERATION >Format >Country in the setup menu is set to [NTSC Area] or [NTSC(J) Area]

50i/25P/50P: When OPERATION >Format >Country in the setup menu is set to [PAL Area]

b) 59.94i after 2-3 pulldown is recorded

c) When the optional CBK-MD01 is installed

d) Converted to PsF and recorded

Selecting the Recording Mode

Select the recording mode between UDF and FAT.

- 1 Select **OPERATION >Format >File System** in the setup menu (*see page 112*).

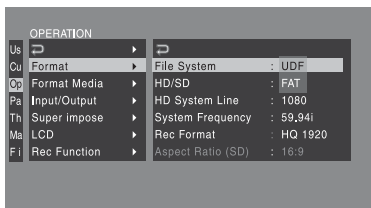

- 2 Turn the **MENU knob** to select **[UDF]** or **[FAT]**, and press the knob.
A confirmation message appears.
- 3 Select **[Execute]** to execute, or select **[Cancel]** to cancel, and then press the **MENU knob**.
- 4 Power the camcorder off and on again.

Changing the Video Format

Refer to the above table and change the settings of the relevant items.

- 1 Select **OPERATION >Format** in the setup menu (*see page 112*).

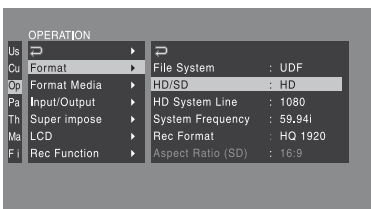

- 2 Turn the **MENU knob** to select the item to change, and press the knob.
- 3 Turn the **MENU knob** to change the setting, and press the knob.
A confirmation message appears.

- 4 Select **[Execute]** to execute, or select **[Cancel]** to cancel, and then press the **MENU knob**.
- 5 When the setting of **HD/SD** or **Country** was changed, power the camcorder off and on again.

Adjusting the Black Balance and the White Balance

To ensure excellent image quality when using this camcorder, conditions may require that both the black balance and the white balance be adjusted. Black balance and white balance adjustment values that are automatically set by the camcorder and the various settings are stored in the camcorder memory and retained even when the power is turned off.

Black balance adjustment

The black balance will require adjustment in the following cases.

- When the camcorder is used for the first time
- When the camcorder has not been used for a long time
- When the camcorder is used under conditions in which the surrounding temperature has changed greatly
- When the GAIN selector (L/M/H/Turbo) values have been changed by using OPERATION >Gain Switch in the setup menu.

It is not usually necessary to adjust the black balance when using the camcorder after it has been off.

White balance adjustment

Always readjust the white balance when the lighting conditions change.

Adjusting the Black Balance

In automatic black balance mode, adjustments are performed in the following order: black set and black balance. Manual black balance adjustment can be selected from the setup menu.

Automatic black balance adjustment is disabled in the following case.

- During recording
- In a special recording modes (Picture Cache Rec, Interval Rec, Frame Rec, Slow & Quick)
- When the shutter mode is SLS

1 Set the OUTPUT/DCC switch to CAM.

2 Push the AUTO W/B BAL switch to BLACK and release the switch.

The message “Executing...” appears during execution, and changes to “Done” when the adjustment finishes. Adjustment values are saved to memory automatically.

Notes

- During the black balance adjustment, the iris is automatically closed.
- During the black balance adjustment, the gain selection circuit is automatically activated so you may see flickering on the viewfinder screen, but this is not a fault.
- Output from the i.LINK connector stops temporarily if you execute black balance adjustment during i.LINK output. Output from the connector resumes when black balance adjustment finishes.

If automatic black balance adjustment cannot be made

If the black balance adjustment cannot be completed normally, an error message will appear for about three seconds on the viewfinder screen. Possible messages are listed below.

Error message	Meaning
NG: Iris Not Closed	The lens iris did not close; adjustment was impossible.
NG: Timeout	Adjustment could not be completed within the standard number of attempts.
NG: Out of Range	The difference between the reference value and the current value is so great that it exceeds the range. Adjustment was impossible.

If any of the above error messages is displayed, retry the black balance adjustment.

If the error message occurs again, an internal check is necessary.

For information about this internal check, refer to the Maintenance Manual.

Note

If the lens cable is not firmly connected to the LENS connector, it may not be possible to adjust the lens iris. If this happens, the black balance will be incorrect.

Adjusting the White Balance

1 Set the switches and selectors as shown below.

- GAIN switch: L (set to a gain value that is as small as possible)
- OUTPUT/DCC switch: CAM
- WHITE BAL switch: A or B ¹⁾

1) Adjustment values are saved to memory B only when OPERATION >White Setting >White Switch in the setup menu, is set to [Memory].

2 Set the FILTER selector to suit the lighting conditions as follows.

3 Place a white test card under the same lighting conditions as for the subject to be shot and zoom up to it.

Alternatively, any white object such as a cloth or a wall can be used.

The absolute minimum white area is as follows.

Rectangle centered on the screen. The lengths of the sides are 70% of the length and width of the screen.

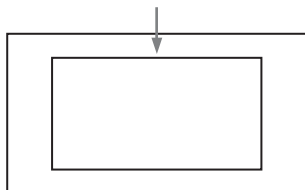

Note

Make sure there are not bright spots in the rectangle.

4 Adjust the lens iris.

Manually adjusted lens: set the iris to an appropriate setting.

Lens with automatic iris: set the automatic/manual switch on the lens to automatic.

5 Push the AUTO W/B BAL switch to WHITE and then release the switch.

The message “Executing...” appears during execution, and changes to “OK: (color temperature of subject)” when the adjustment finishes.

The adjustment values are saved automatically in the memory selected in step 1 (A or B).

Note

If the camcorder has a zoom lens with an automatic iris, the iris may hunt ¹⁾ during the adjustment. To prevent this, adjust the iris gain knob (indicated as IG, IS, or S) on the lens.

For details, refer to the lens operation manual.

- 1) **Hunting:** Repeated brightening and darkening of the image, resulting from repeated response to automatic iris control.

If the automatic white balance adjustment cannot be made

If the white balance adjustment cannot be completed normally, an error message will appear for about three seconds on the viewfinder screen. Possible messages are listed below.

Error message	Meaning
NG: Low Light	The white video level is too low. Either open the lens iris or increase the gain.
NG: Timeout	Adjustment could not be completed within the standard number of attempts.
NG: High Light	The white video level is too high. Either stop down the lens iris or change the ND filter.

If any of the above error messages is displayed, retry the white balance adjustment. If the error message occurs again, an internal check is necessary.

For information about this internal check, refer to the Maintenance Manual.

If you have no time to adjust the white balance

Set the WHITE BAL switch to PRST. This makes it possible to automatically set the white balance to 5600K (factory default value) by pressing the COLOR TEMP. button. The color temperature to which the white balance is set when the COLOR TEMP. button is pressed can be selected from among 3200K, 4300K, 5600K, and 6300K on OPERATION >Assignable SW in the setup menu. You can also assign color temperatures to the ASSIGN. 1/3 switches or ASSIGNABLE 4/5 switches.

To change the color temperature when the ND filter is switched

You can assign electrical CC (color correction) filters to ND filters (*see page 17*). This allows you to change the color temperature automatically when the ND filter is switched.

- 1** Set **MAINTENANCE >White Filter >ND Filter C.Temp** in the setup menu (*see page 143*) to **On**.
- 2** To assign an electrical CC filter to **FILTER selector position number 1**, select **[ND FLT C.Temp<1>]**. To assign it to positions 2 to 4, select **[ND FLT C.Temp<2-4>]**.
- 3** Turn the **MENU knob** to select the **desired color temperature**.
As you turn the MENU knob, the color temperature changes as follows: 3200K ↔ 4300K ↔ 5600K ↔ 6300K.
- 4** Repeat steps 2 and 3 as required.

To switch between electrical CC filters with an assignable switch

You can assign the function that switches between electrical CC filters to an assignable switch. This allows you to switch between color temperatures (3200K/4300K/5600K/6300K) that have been assigned to up to four positions (A to D) with each press of the assignable switch. Regardless of assignments to assignable switches, you can also switch between the color temperatures assigned to each position from a RM-B150/B750 Remote Control Unit.

- 1** Select **MAINTENANCE >White Filter in the setup menu** (*see page 143*).
- 2** Select the position to which to assign a CC filter by selecting one of **[Electrical CC<A>]** to **[Electrical CC <D>]**, and then turn the **MENU knob** to select the **desired color temperature**.
As you turn the MENU knob, the color temperature changes as follows: 3200K ↔ 4300K ↔ 5600K ↔ 6300K.

To set no color temperature

Select “----” with Electrical CC<C> or <D> selected.

When the assignable switch is pressed, the setting for that position is not displayed. For example, if “----” is set for one position, then switching between the remaining three positions is carried out.

- 3** Repeat step 2 as required.
- 4** Assign the electrical CC filter switching function (**ELECTRICAL CC**) to an assignable switch (*see page 158*).

White balance memory

Values stored in memory are held until the white balance is next adjusted even when the camcorder power is turned off.

The camcorder has two white balance memories, A and B. You can automatically save adjustment values for each ND filter in the memory that corresponds to the WHITE BAL switch setting (A or B). The camcorder has four built-in ND filters, allowing you to save a total of eight adjustment values (4 × 2). However, the contents of the memories are not linked to ND filter settings in the following cases.

- When the number of memories allocated to each of A and B is limited to one by setting **OPERATION >White Setting >Filter White Memory** in the setup menu to **Off**.
- When the electrical CC filter switching function has been assigned to an assignable switch, or when a remote control unit has been connected. (In these cases, the contents of white balance memory are linked to electrical CC filter positions (A to D).)

Also, when **OPERATION >White Setting >White Switch** in the setup menu is set to **[ATW (Auto Tracing White Balance)]**, and the **WHITE BAL** switch is set to **B**, the **ATW** function is activated to automatically adjust the white balance of the picture being shot for varying lighting conditions.

Setting the Electronic Shutter

Shutter Modes

The shutter modes that can be used with the electronic shutter and the shutter speeds that can be selected are listed below.

Standard mode

Select this mode for shooting fast-moving subjects with little blurring.

You can set the shutter speed in one of two shutter modes: Speed mode, in which the speed is set in seconds, and Angle mode, in which the speed is set in degrees.

Speed mode

System frequency	Shutter speed (unit: seconds)
59.94i	$\frac{1}{60}$, $\frac{1}{100}$, $\frac{1}{120}$, $\frac{1}{125}$, $\frac{1}{250}$, $\frac{1}{500}$
59.94P	$\frac{1}{1000}$, $\frac{1}{2000}$
50i	
50P	
29.97P	$\frac{1}{40}$ ^{a)} , $\frac{1}{50}$ ^{a)} , $\frac{1}{60}$, $\frac{1}{100}$, $\frac{1}{120}$, $\frac{1}{125}$, $\frac{1}{250}$, $\frac{1}{500}$, $\frac{1}{1000}$, $\frac{1}{2000}$
25P	$\frac{1}{33}$ ^{a)} , $\frac{1}{50}$ ^{a)} , $\frac{1}{60}$, $\frac{1}{100}$, $\frac{1}{120}$, $\frac{1}{125}$, $\frac{1}{250}$, $\frac{1}{500}$, $\frac{1}{1000}$, $\frac{1}{2000}$
23.98P	$\frac{1}{32}$ ^{a)} , $\frac{1}{48}$ ^{a)} , $\frac{1}{50}$ ^{a)} , $\frac{1}{60}$, $\frac{1}{96}$, $\frac{1}{100}$, $\frac{1}{120}$, $\frac{1}{125}$, $\frac{1}{250}$, $\frac{1}{500}$, $\frac{1}{1000}$, $\frac{1}{2000}$

a) This speed cannot be selected when the camcorder is in Slow & Quick Motion mode and OPERATION >Rec Function >Frame Rate in the setup menu is set to a value that is greater than the system frequency.

Angle mode

180°, 90°, 45°, 22.5°, and 11.25°

ECS (Extended Clear Scan) mode

Select this mode for obtaining images with no horizontal bands of noise when shooting subjects such as monitor screens.

As shown in the following tables, the range of shutter speeds that can be set varies depending on whether the Slow & Quick Motion (S&Q) function is on or off.

System lines: 1080

System frequency	Shutter speed (unit: Hz)	
	S&Q: Off	S&Q: On
59.94i	60.00 to 3800	—
50i	50.00 to 3500	—
29.97P	29.99 to 4100	32.01 to 4100
23.98P	23.99 to 3700	32.02 to 3700
25P	25.00 to 3900	32.03 to 3900

System lines: 720

System frequency	Shutter speed (unit: Hz)	
	S&Q: Off	S&Q: On
59.94P	60.07 to 4100	32.01 to 4100
50P	50.03 to 3900	32.03 to 3900
29.97P	29.99 to 4100	32.01 to 4100
23.98P	23.99 to 3700	32.02 to 3700
25P	25.00 to 3900	32.03 to 3900

SLS (slow speed shutter) mode

Select this mode for shooting subjects in low level lighting conditions.

OPERATION >Format >HD System Line setting in the setup menu	Number of accumulated frames
1080	2, 3, 4, 5, 6, 7, 8, 16
720	2, 4, 6, 8, 16

Notes

- SLS mode cannot be used when the video format is SP 1440/23.98P or when the camcorder is in Slow & Quick Motion mode.
- It is not possible to use SLS mode when OPERATION >Input/Output >i.Link I/O is set to [Enable] in the setup menu.
- It is not possible to output the color bar signal, turn the SLS mode on or off, or change the number of accumulated frames when the number of accumulated frames is set to 16.

Selecting the Shutter Mode and Shutter Speed

Notes

- When the automatic iris is used, the iris opens wider as the shutter speed increases, thus reducing the depth of field.
- The selectable shutter speeds vary depending on the current system frequency.

To switch between Speed mode and Angle mode

- 1 Select **OPERATION >Shutter Select >Shutter Select** in the setup menu (see page 124).
- 2 Turn the **MENU knob** to select **Second or Degree**, and then press the knob.

To set the shutter mode and standard-mode shutter speed

Once the shutter speed is selected, it is retained even when the camcorder power is turned off.

- 1 Push the **SHUTTER selector** from **ON to SELECT**.
The current shutter setting indication appears for about three seconds.
- 2 Before the shutter setting indication disappears, push the **SHUTTER selector** down to **SELECT** again and repeat this until the desired mode or speed appears.

When all modes and speeds are displayed, the display changes in the following order.

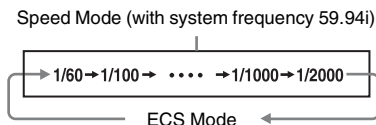

Note

Depending on the frame rate setting (see page 83), some shutter speeds cannot be selected in Slow & Quick Motion mode. These speeds are replaced by the slowest selectable shutter speed.

Example: If you perform Slow & Quick Motion shooting when setting the frame rate to 60 and the video format to HQ1280/29.97P

The shutter speed is indicated as follows.

When Slow & Quick Motion mode is off

1/40 → 1/50 → 1/60 → 1/100 → ...

When Slow & Quick Motion mode is on

1/60 → 1/60 → 1/60 → 1/100 → ...

To set the shutter speed in ECS mode

- 1 Set the shutter mode to **ECS** (see the previous item).
- 2 Turn the **MENU knob** to select the desired frequency or number of frames.

To set the shutter speed in SLS mode

- 1 Set **OPERATION >Shutter >Slow Shutter** in the setup menu to **[On]** (see page 124).
- 2 Select the desired number of accumulated frames with **OPERATION >Shutter >SLS Frames** in the setup menu.

Changing the Reference Value for Automatic Iris Adjustment

The reference value for automatic iris adjustment can be changed to aid the shooting of clear pictures of back-lit subjects, or to prevent blown-out highlights. The reference value for the lens iris can be set within the following range with respect to the standard value.

- 0.25 to 1 (increasing by increments of 0.25):
About 0.25 to 1 stop further open
- -0.25 to -1 (decreasing by increments of 0.25):
About 0.25 to 1 stop further close

Also you can set the area where light detection occurs.

To change the reference value

- 1 Set **OPERATION >Auto Iris >Iris Override in the setup menu to On** (see page 122).
- 2 Set the **MENU ON/OFF switch to OFF**.
- 3 Turn the **MENU knob to change the reference value**.

Note

Be sure to confirm that the current shutter mode is not ECS.

An indicator of the current reference value is shown at the iris position indication (see page 34) on the viewfinder screen.

To make the iris more open

Turn the MENU knob counterclockwise as seen from the front of the camcorder. Select one of 0.25, 0.5, 0.75, or 1.

To stop down the iris

Turn the MENU knob clockwise as seen from the front of the camcorder. Select one of -0.25, -0.5, -0.75, or -1.

The changed reference value is retained until the power of the camcorder is turned off. Even if the reference value is changed, it reverts to the standard value every time the power is turned on.

To set the automatic iris window

- 1 Set **OPERATION >Auto Iris >Iris Window Indication in the setup menu to On**.

The current automatic iris window appears on the viewfinder screen.

If it is not necessary to display the auto iris window on the screen, set to Off.

- 2 Turn the **MENU knob to select Iris Window, and then press the knob**.
- 3 Turn the **MENU knob until the desired auto iris window appears, and then press the knob**.



The shaded parts indicate the area where light detection

If you select "Var", the following items become effective and you can set the window of the desired size. Set the following items with **MAINTENANCE >Auto Iris2**.

Item	Setting
Iris Var Width	The width of the window
Iris Var Height	The height of the window
Iris Var H Pos	The position of the window in the horizontal direction
Iris Var V Pos	The position of the window in the vertical direction.

When you exit the menu, the auto iris window selected in step 3 appears.

Unless you need to keep this window displayed, set **OPERATION >Auto Iris >Iris Window Indication in the setup menu to Off**.

To counter problems with very bright highlights

If the subject is too bright, the iris may close too much, leaving the overall image dark, or the highlights may be blown out. In such cases, setting the highlight clip function on reduces the luminance range, avoiding problems from the automatic iris correction.

Set **OPERATION >Auto Iris >Clip High Light in the setup menu to On**.

Adjusting the Audio Level

When you set the AUDIO SELECT switch to AUTO, the input levels of analog audio signals recorded on each channel are adjusted automatically. You can also make manual adjustments.

Note

Even if you set the AUDIO SELECT switch to AUTO, the input levels of digital audio signals are not adjusted automatically.

Target audio level for manual audio level adjustment

Make adjustment using -20 dB as the target level. If the audio level meter shows a maximum level of 0 dB, then it indicates that the input audio level is excessive.

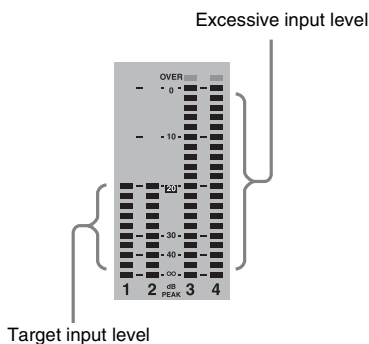

Manually Adjusting the Audio Levels of the Audio Inputs from the AUDIO IN CH-1/CH-2 Connectors

- To adjust the signal input to the AUDIO IN CH-1 or CH-2 connector, set the AUDIO IN CH1 or CH2 switch to REAR.

To adjust both input signals, set both switches to REAR.

- Set the AUDIO SELECT switch(es) corresponding to the channel(s) selected in step 1 to MANUAL.
- With the LEVEL knob(s) for the channel(s) selected in step 1, adjust so that the audio level meter shows up to -20 dB for a normal input volume.

Correspondence between recording level adjustments and audio level controls

On MAINTENANCE >Audio in the setup menu, you can select which audio level control controls the audio recording level of the input to each of the AUDIO IN CH-1/CH-2 connectors. The correspondences between the settings of the menu items and the controls are as follows.

Rear1/WRR Level: Channel 1 recording level

Setting	Knob
Side1	LEVEL (CH1) knob
Front	MIC LEVEL control
Front+Side1	LEVEL (CH1) knob and MIC LEVEL control (linked operation)

Rear2/WRR Level: Channel 2 recording level

Setting	Knob
Side2	LEVEL (CH2) knob
Front	MIC LEVEL control
Front+Side2	LEVEL (CH2) knob and MIC LEVEL control (linked operation)

Note

When you have operation of the LEVEL (CH1/CH2) knobs and MIC LEVEL control linked together, if the MIC LEVEL control is set to 0, the audio signals on channels 1 and 2 cannot be recorded. Check the position of the MIC LEVEL control before adjusting the LEVEL (CH1/CH2) knobs.

Manually Adjusting the Audio Level of the MIC IN Connector

- Set either or both of the AUDIO IN switch(es) to FRONT.

- 2 Set the **AUDIO SELECT** switch(es) for the desired channel(s) selected in step 1 to **MANUAL**.
- 3 Turn the **MIC LEVEL** control, and adjust so that the audio level meter shows up to **-20 dB** for a normal input volume.

Correspondence between recording level adjustments and audio level controls

On **MAINTENANCE >Audio** in the setup menu, you can select which audio level control controls the audio recording level of the front microphone input. The correspondences between the settings of the menu items and the controls are as follows.

MIC CH1 Level: Channel 1 recording level

Setting	Knob
Side1	LEVEL (CH1) knob
Front	MIC LEVEL control
Front+Side1	LEVEL (CH1) knob and MIC LEVEL control (linked operation)

MIC CH2 Level: Channel 2 recording level

Setting	Knob
Side2	LEVEL (CH2) knob
Front	MIC LEVEL control
Front+Side2	LEVEL (CH2) knob and MIC LEVEL control (linked operation)

Note

When you have operation of the **MIC LEVEL** control and **LEVEL (CH1/CH2)** knobs linked together, if the **LEVEL (CH1/CH2)** knobs are set to 0, the audio signals on channels 1 and 2 cannot be recorded. Check the position of the **LEVEL (CH1/CH2)** knobs before adjusting the **MIC LEVEL** control.

Recording Audio on Channels 3 and 4

Selecting the recorded audio

You can select the audio recorded on audio channels 3 and 4 with the **AUDIO IN CH3/CH4** switches.

CH3 switch	Channel 3 recording target
FRONT	Front microphone audio
REAR	Audio signal input to AUDIO IN CH1 connector
WIRELESS	Wireless microphone audio

CH4 switch	Channel 4 recording target
FRONT	Front microphone audio
REAR	Audio signal input to AUDIO IN CH2 connector
WIRELESS	Wireless microphone audio

You can have the selection made automatically, as follows.

To automatically select the same audio as on channels 1 and 2

Set **MAINTENANCE >Audio >Audio CH3/4 Mode** of the setup menu to **[Ch1/2]**.

Adjusting the audio recording levels

To adjust automatically

Set the **AUDIO SELECT CH 3-4** switch to **AUTO**.

To adjust manually

- 1 Set the **AUDIO SELECT CH 3-4** switch to **MANUAL**.
- 2 Select the knobs that adjust the audio levels with the **Audio CH3 Level** and **Audio CH4 Level** items under **MAINTENANCE >Audio** in the setup menu.

Audio CH3 Level: Channel 3 recording level

Setting	Knob
Side3	LEVEL (CH3) knob
Front	MIC LEVEL control
Front+Side3	LEVEL (CH3) knob and MIC LEVEL control (linked operation)

Audio CH4 Level: Channel 4 recording level

Setting	Knob
Side4	LEVEL (CH4) knob
Front	MIC LEVEL control

Setting	Knob
Front+Side4	LEVEL (CH4) knob and MIC LEVEL control (linked operation)

You can now adjust the levels of audio channels 3 and 4 with the knobs selected here.

Setting the Time Data

Note

When picture cache mode is enabled, it is not possible to set time data, even if you set the F-RUN/SET/R-RUN switch to SET. If you want to set time data, first exit picture cache mode.

Setting the Timecode

The timecode setting range is from 00 : 00 : 00 : 00 to 23 : 59 : 59 : 29 (hours : minutes : seconds : frames).

- 1 **Press the DISP SEL/EXPAND button to switch the display in the LCD monitor to status display.**
- 2 **Set the DISPLAY switch to TC.**
- 3 **Set the PRESET/REGEN/CLOCK switch to PRESET.**
- 4 **Set the F-RUN/SET/R-RUN switch to SET.**
The first (leftmost) digit of timecode flashes.
- 5 **Use the up and down arrow buttons to change values, and use the left and right arrow buttons to move the flashing digit. Repeat until all digits are set.**
To reset the timecode value to 00:00:00:00
Press the RESET/RETURN button.
- 6 **Set the F-RUN/SET/R-RUN switch to F-RUN or R-RUN.**
F-RUN: Free run. The timecode generator keeps running.
R-RUN: Recording run. The timecode generator runs only while recording.

To set the drop frame mode/non-drop frame mode

You can select the drop frame (DF) mode or non-drop frame (NDF) mode on MAINTENANCE >Timecode in the setup menu.

To make the timecode consecutive

When the F-RUN/SET/R-RUN switch is set to R-RUN, recording a number of scenes on the media normally produces consecutive timecode. However, once you remove the media and record on another media, the timecode will no longer be consecutive when you use the original media again for recording. In this case, to make the timecode consecutive, set the PRESET/REGEN/CLOCK switch to REGEN.

Saving the real Time in the Timecode

Setting the PRESET/REGEN/CLOCK switch to CLOCK saves the real time in the timecode.

When it is necessary to set the actual time, use MAINTENANCE >Clock Set >Date/Time in the setup menu.

For details, see "Setting the Date/Time of the Internal Clock" (page 41).

Setting the User Bits

By setting the user bits (up to 8 hexadecimal digits), you can record user information such as the date, time, or scene number on the timecode track.

- 1 Press the DISP SEL/EXPAND button to switch the display in the LCD monitor to status display.**
- 2 Set the DISPLAY switch to U-BIT.**
- 3 Set the F-RUN/SET/R-RUN switch to SET.**
The first (leftmost) digit flashes.
- 4 Use the up and down arrow buttons to change values, and use the left and right arrow buttons to move the flashing digit. Repeat until all digits are set.**

To reset the user bit data to 00 00 00 00
Press the RESET/RETURN button.

- 5 Set the F-RUN/SET/R-RUN switch to F-RUN or R-RUN, corresponding to the desired operating mode for the timecode generator.**

To store the user bit setting in memory

The user bit setting (apart from the real time) is automatically retained in memory even when the power is turned off.

Synchronizing the Timecode

You can synchronize the internal timecode generator of this camcorder with an external generator for the regeneration of an external timecode. You can also synchronize the timecode generators of other camcorders/VTRs with the internal generator of this camcorder.

Connections for timecode synchronization

Connect both the reference video signal and the external timecode as illustrated below.

Example 1: Synchronizing with an external timecode

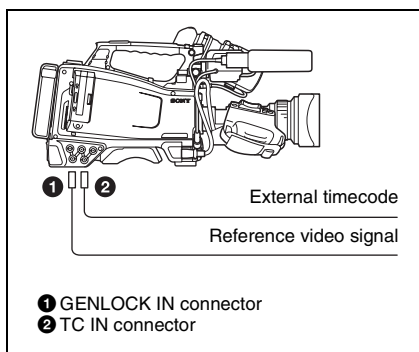

Example 2: Interconnecting a number of camcorders (including one reference camcorder)

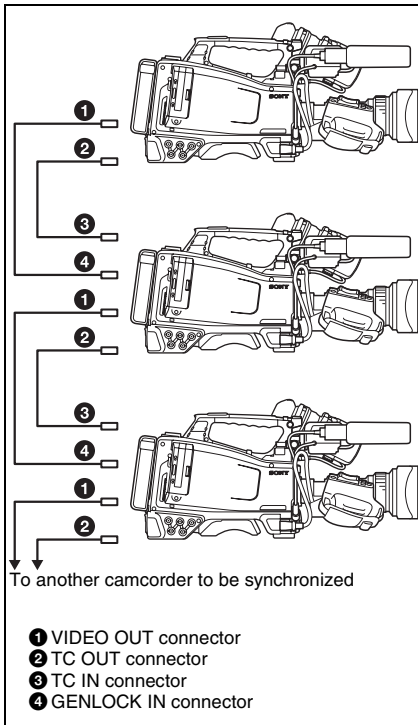

To lock the timecode to an external source

- 1 Turn on the **POWER** switch.
- 2 Set the **PRESET/REGEN/CLOCK** switch to **PRESET**.
- 3 Set the **F-RUN/SET/R-RUN** switch to **F-RUN**.
- 4 Set the **DISPLAY** switch to **TC**.
- 5 Supply a timecode signal and a reference video signal complying with the **SMPTE** standard and in proper phase relationship, to the **TC IN** connector and to the **GENLOCK IN** connector, respectively.

This operation synchronizes the internal timecode generator with the external timecode. After about 10 seconds, you can disconnect the external timecode without losing the synchronization.

Notes

- When you finish the above procedure, the internal timecode is immediately synchronized with the external timecode and the counter display will show the value of the external timecode. However, wait for a few seconds until the sync generator stabilizes before recording.
- If the frequency of the reference video signal is not the same as the system frequency of the camcorder, the camcorder cannot be correctly genlocked. In such a case, the internal timecode is not correctly synchronized with the external timecode.

User bit settings during timecode synchronization

When the timecode is synchronized, only the time data is synchronized with the external timecode value.

To release the timecode synchronization

First disconnect the external timecode, then set the **F-RUN/SET/R-RUN** switch to **R-RUN**.

To change the power supply from the battery pack to an external power supply during timecode synchronization

To maintain a continuous power supply, connect the external power supply to the **DC IN** connector before removing the battery pack. You may lose timecode synchronization if you remove the battery pack first.

Camcorder synchronization during timecode synchronization

During timecode synchronization, the camcorder is genlocked to the reference video signal input from the **GENLOCK IN** connector.

Setting Shot Data

While color bars are output, shot data can be displayed.

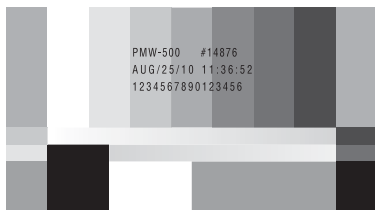

Example display of shot data

You can select which shot data is superimposed on the color bars with OPEARTION >Shot Display in the setup menu.

Shot Date

To superimpose the shot date, turn the MENU knob to set Shot Date to [On] and press the knob.

Shot Time

To superimpose the shot time, turn the MENU knob to set Shot Time to [On] and press the knob.

Shot Model Name

To superimpose the model name, turn the MENU knob to set Shot Model Name to [On] and press the knob.

Shot Serial Number

To superimpose the serial number, turn the MENU knob to set Shot Serial Number to [On] and press the knob.

Shot ID Select

To superimpose a shot ID created arbitrarily, turn the MENU knob to set Shot ID Select to one of [ID-1] to [ID-4] and press the knob.

To create a shot ID, see the next section “Creating a Shot ID”.

Creating a Shot ID

Up to four shot IDs of up to 16 characters can be created.

To create a shot ID

- 1 With OPEARTION >Shot ID in the setup menu, turn the MENU knob to select a shot ID to create (ID-1 to ID-4) and press the knob.



The shot ID setting screen appears.

- 2 Follow the procedure in “To enter text” (page 110) to create a shot ID.

Checking Camcorder Settings and Status Information (Status Screens)

The status screens allow you to check camcorder settings and various types of status information. There are five status screens, listed below.

Status screen	Information displayed
CAMERA status	Settings and status information related to shooting
AUDIO status	Settings and status information related to audio input and output
VIDEO status	Settings and status information related to recording and playback
ASSIGN SWITCH status	Names of functions assigned to assignable switches
BATTERY/MEDIA status	Status of the battery mounted on the camcorder and the media status

To display status screens

With no menu is displayed, press the MENU CANCEL/PRST/ESCAPE switch up to the CANCEL/PRST side. Each push selects the next status screen, in the order given in the table above.

CAMERA status screen

This screen displays settings and status information related to shooting.



White Bal: White balance status

Gain: GAIN switch status

Zoom Speed: Zoom speed set with the lens ZOOM button

Zebra: Zebra status

Skin Detail: Skin details status

AUDIO status screen

This screen displays settings and status information related to audio input and output.



CH-1/CH-2/CH-3/CH-4: Audio level meters and input sources

Wind Filter: Wind filter settings

VIDEO status screen

This screen displays settings and status information related to recording and playback.

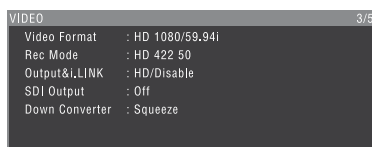

Video Format: Video format

Rec Mode: Recording bit rate (HD mode only)

Output&i.LINK: Output&i.LINK setting and i.LINK usage status

SDI Output: HD/SD SDI OUT connector output setting

Down Converter: SD output down converter setting (HD mode only)

ASSIGN SWITCH status screen

This screen displays the names of the functions assigned to assignable switches

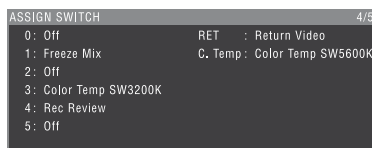

BATTERY/MEDIA status screen

This screen displays the status of the battery mounted on the camcorder and the media status.

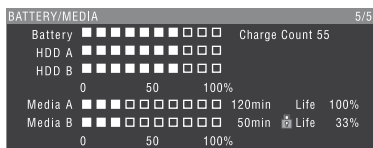

Battery: The remaining battery capacity

Charge Count: The number of times the battery has been charged

HDD A/HDD B: Remaining battery capacity of PHU-120R (in FAT mode)

Media A/Media B:

- Remaining capacity of media
- Recordable time
- Approximate writable lifetime (Life)
“Life 100%” is shown for unused media.

Handling SxS Memory Cards

This camcorder records video and audio on SxS memory cards (not supplied) loaded into one or both of its memory card slots.

The PHU-120R Professional Harddisk Unit or MEAD-MS01/SD01 Media Adaptor can also be used for recording (when the recording mode is FAT). For details, refer to the Supplement supplied in the CD-ROM (labeled “Manuals for Solid-State Memory Camcorder”).

About SxS Memory Cards

SxS memory cards that can be used with this camcorder

Use the following Sony SxS memory cards (SxS PRO or SxS-1) with this camcorder.

SxS PRO

- SBP-16 (16 GB)
- SBP-32 (32 GB)

SxS-1

- SBS-32G1A (32 GB)
- SBS-64G1A (64 GB)

Proper operation cannot be guaranteed when memory cards other than SxS PRO and SxS-1 are used.

The memory cards listed above comply with the ExpressCard memory card standard.

- SxS, SxS PRO and SxS-1 are trademarks of Sony Corporation.
- The ExpressCard label and logo are property of the Personal Computer Memory Card International Association (PCMCIA) and are licensed to Sony Corporation. Other trademarks and trade names are the property of their respective owners.

Notes on the use of SxS memory cards

- Recorded data may be lost or corrupted in the following cases.
 - When the camcorder is subjected to shock or vibrations during reading, writing, or formatting of an SxS memory card, and when the camcorder is powered off or an SxS memory card is removed during reading, writing, or formatting
 - When the camcorder is used in an environment subject to static electricity or electric noise
- Do not use or store SxS memory cards in locations that are:
 - Outside the specified environmental ranges
 - Very hot, such as in vehicles parked in the sun during summer, or exposed to direct sunlight, or near heaters
 - Subject to high humidity and corrosion
- When inserting a memory card, insert with the label side facing the correct direction.
- Carry and store SxS memory cards in their cases, and lock the cases securely.

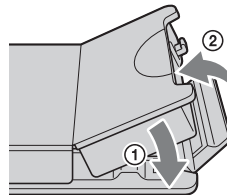

- To use SxS-1 memory card “SBS-32G1” in UDF mode, the software may need to be updated. For details, access the Sony website closest to your area. (Refer to the top page of the CD-ROM Manual on the supplied CD-ROM.)
- Guard against accidents and inadvertent data loss by backing up the data stored on SxS memory cards. Sony cannot be responsible for any consequences of damage to or loss of data stored on SxS memory cards.
- Do not attach anything other than the supplied labels in the designated label space. When attaching a label, make sure it does not protrude beyond the label space.

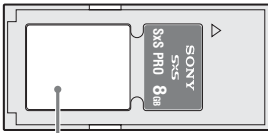

Label space

- Use this camcorder to format SxS memory cards that will be used with this camcorder. When memory cards are formatted on another unit, the format is regarded as an invalid format, making it necessary to format the memory cards again. However, note that the format and delete functions of this camcorder do not completely remove data from memory cards. Before discarding or disposing of a memory card, erase it using commercial data erasure software, or physically destroy it. Sony cannot be responsible for any failure to erase data completely.
- Clip operations may not be possible when the remaining capacity of the media is low. In this case, use a computer to delete unneeded files and try again.
- Open the memory card case completely before storing a card in the case or removing a card from the case.



Preventing accidental erasure

You can prevent accidental recording, editing, and deletion of data on an SxS memory card by setting the write protect switch to the WP side.

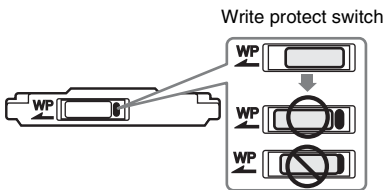

Note

Do not touch the write protect switch while an SxS memory card is loaded in a card slot. Eject the card before setting the write protect switch.

Loading and Ejecting SxS Memory Cards

To load SxS memory cards

- 1 Slide the cover to the left to open.
- 2 Insert an SxS memory card into a card slot.

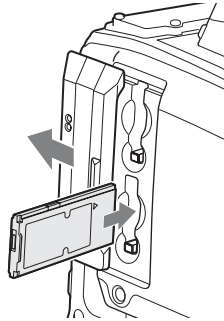

Insert with the label side facing right.

The ACCESS lamp lights in orange, and then lights in green to indicate that the memory card is usable.

- 3 Close the cover.

ACCESS lamp status indications

Card slots A and B each have an ACCESS lamp to indicate the slot status.

Lamp	Slot status
Lights in orange	Accessing the SxS memory card (lights during data reading and writing)
Lights in green	Standby (the loaded SxS memory card is ready for recording or playback)
Not lit	<ul style="list-style-type: none"> • No SxS memory card is loaded. • An unusable card is loaded. • An SxS memory card is loaded, but the other slot is selected.

To eject SxS memory cards

- 1 **Open the cover, and then press the EJECT button to release the lock and pull the button out.**

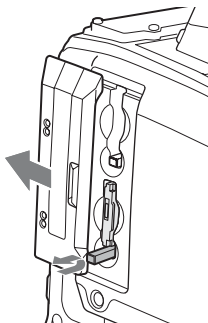

Press the button once to release the lock.

- 2 **Press the EJECT button again to eject the card.**

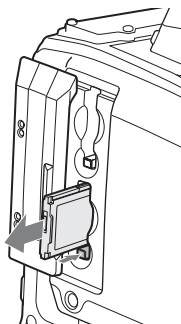

Note

Data integrity cannot be guaranteed if you power the camcorder off or remove a memory card while the card is being accessed. Doing so may corrupt all data recorded on the card. Always make sure that the ACCESS lamp is lit green or not lit before you power the camcorder off or remove a memory card.

Selecting the SxS Memory Card to Use

When SxS memory cards are loaded in both slot A and slot B, you can press the SLOT SELECT button to select the SxS memory card to use.

The camcorder switches automatically to the other card if the selected card becomes full during recording.

Note

The SLOT SELECT button is disabled during playback. Even when pressed, it does not change the selected slot. Button operations are enabled when a thumbnail screen (see page 91) is displayed.

Formatting (Initializing) SxS Memory Cards

When you load an unformatted memory card, load a memory card that has been formatted to other specifications, or load a memory card that has been formatted in UDF mode into the camcorder set to FAT mode, a message to confirm if formatting is to be executed appears in the viewfinder (see page 71). In this case, format the memory card in the following way. SxS memory cards are formatted in FAT mode as factory default.

Note

SxS memory cards must be formatted on an XDCAM EX device or on this camcorder. Cards in other formats cannot be used.

To format (initialize) a memory card

If the message for formatting is displayed, turn the MENU knob to select “Execute”, and then press the knob.

Execution of the format starts.

During execution of the format, a progress indication appears (%), and the ACCESS lamp lights in orange.

When formatting is completed, the completion message is displayed for three seconds.

Recording and playback during format execution

Even during execution of a format, recording and playback are possible using an SxS memory card loaded into the other card slot.

If the format operation fails

A format operation may fail because the SxS memory card is write protected, or because it is not the type of card specified for use with this camcorder.

In this case, an error message appears. Following the instructions in the error message and exchange the card for an SxS memory card that can be used with this camcorder.

To format by menu operation

When no formatting message is displayed, you can execute formatting by menu operation.

- 1 Select **OPERATION >Format Media** in the setup menu (see page 113).
- 2 Select **[Media(A)] (slot A)** or **[Media(B)] (slot B)**.
- 3 Turn the **MENU knob** to select **[Execute]**, and then press the knob. The confirmation message for formatting is displayed on the viewfinder screen.
- 4 Turn the **MENU knob** to select **“Execute”**, and press the knob. Execution of the format starts.

During execution of the format, a progress indication appears (%), and the ACCESS lamp lights in orange.

When formatting is completed, the completion message is displayed for three seconds.

Notes

- All data is erased when you format a memory card, including setup files and all of the recorded video data.
- Use the format function of this camcorder to format SxS memory cards for use on this camcorder. The formats of cards formatted on other devices are not recognized as valid formats, making it necessary to format them again on this camcorder.

If You Load a Memory Card Formatted in the Different Recording Mode from the Mode Selected on the Camcorder

An error message or a message to confirm if formatting is to be executed appears.

Cases in which an error message appears

The message “Cannot Use Media(A)/Unsupported File System” appears in the viewfinder in the following cases.

- An SxS memory card which was used for recording in UDF mode is loaded into the camcorder set to FAT mode.
- An SxS memory card which was used for recording in FAT mode is loaded into the camcorder set to UDF mode.
- An SxS memory card which was formatted in FAT mode is loaded into the camcorder set to UDF mode.

Cases in which a message to confirm if formatting is to be executed appears

When an SxS memory card which was formatted in UDF mode is loaded into the camcorder set to FAT mode, a message to confirm if formatting is to be executed in FAT mode appears in the viewfinder (see page 70).

Checking the Remaining Recording Time

You can check the remaining capacity of the SxS memory cards loaded in the two slots by checking the recording media remaining capacity display in the viewfinder.

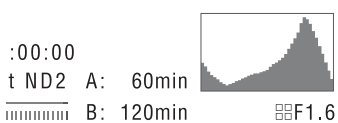

The camcorder calculates the remaining recording time for the media in each slot on the basis of the current video format (recording bit rate), and displays it in units of minutes. You can also check the remaining time in the BATTERY/MEDIA status screen (see page 67).

Note

The  mark appears when a memory card is write protected.

When to exchange SxS memory cards

- The warning message “Media Near Full” appears, the WARNING indicator and the REC indication on the viewfinder screen flash, and the buzzer sounds when the total remaining recording time of the two memory cards falls to five minutes during recording. Exchange one of the cards for media with available recording capacity.

- If you continue recording, the message “Media Full” appears and recording stops when the total remaining recording time falls to 0.

Note

About up to 600 clips can be recorded on one SxS memory card.

The display of remaining recording time changes to “0” and the message “Media Full” appears when the clip limit is reached.

Restoring SxS Memory Cards

If for any reason an error should occur in a memory card, the card must be restored before use.

When you load an SxS memory card that needs to be restored, a message appears in the viewfinder to ask whether you want to restore it.

To restore a card

Turn the MENU knob to select [Execute], and then press the knob.

The restoration starts.

During the restoration, an execution message appears, the progress is displayed (%), and the ACCESS lamp lights in orange.

When the restoration finishes, a completion message is displayed for three seconds.

If restoration fails

- Write protected SxS memory cards and cards on which memory errors have occurred cannot be restored. A warning message appears for such cards. Follow the instructions in the message and unprotect the card or replace it with another card.
- SxS memory cards on which memory errors have occurred may become usable if they are reformatted.
- In some cases, some clips can be restored while others cannot. The restored clips can be played normally.
- If the message “Could not Restore Some Clips” keeps appearing after repeated attempts at restoration, it may be possible to restore the SxS memory card with the following procedure.
 - ① Use the camcorder’s copy function (*see page 102*) or the supplied application software (*see page 170*) to copy the required clips to another SxS memory card.

- ② Format the unusable SxS memory card on the camcorder.
- ③ Copy the required clips back to the newly formatted SxS memory card.

Recording and playback during restoration

Even while restoration is in progress, you can record and play an SxS memory card in the other card slot.

Note

For restoration of media recorded with this camcorder, be sure to use this camcorder. Media recorded with a device other than this camcorder or with another camcorder of different version (even of the same model) may not be restored using this camcorder.

Handling USB Flash Drives

UDF

In UDF mode, you can connect a USB flash drive connected to the external device to record, save and load the following data.

- Record proxy data (*see page 85*)
- Load planning metadata (*see page 87*)
- Save and load setting data (*see page 160*)

The following Sony USB flash drives are recommended for use with this camcorder.

Pocket Bit L Series

- USM16GL
- USM8GL
- USM4GL

Pocket Bit Hi-Speed LX Series

- USM32GLX
- USM16GLX
- USM8GLX
- USM4GLX (available in Japan only)

Notes

- Use USB flash drives with capacity from 4 GB to 32 GB.
- USB flash drives other than the recommended flash drives listed above may not be recognized when connected to the USB connector.

Formatting (Initializing) USB Flash Drives

USB flash drives must be formatted with the FAT32 file system.

Note

Before using a drive, format it on this camcorder or a PC. If a drive formatted on a PC cannot be used, format it on the camcorder.

1 Connect a USB flash drive to the external device connector.

When the drive is unformatted or has been formatted to other specifications, a message to confirm if formatting is to be executed appears on the viewfinder screen.

2 Turn the MENU knob to select “Execute” and press the knob.

When formatting is completed, the message “Format USB Memory Done” is displayed. The \MSSONY\PRO\XDCAM\MEMDISC folder and the \General\Sony\Planning folder are automatically created in the drive.

If the format operation fails

A format operation may fail because the USB flash drive is write protected, or because it is not the type of drive specified for use with this camcorder.

In this case, an error message appears. Following the instructions in the error message and exchange the drive for one that can be used with this camcorder.

To format by menu operation

When no formatting message is displayed, you can execute formatting by menu operation.

1 Connect a USB flash drive to the external device connector.

2 Select OPERATION >USB > Format USB Memory in the setup menu.

3 Turn the MENU knob to select [Execute], and then press the knob.

The confirmation message for formatting is displayed on the viewfinder screen.

4 Turn the MENU knob to select “Execute” and press the knob.

A progress indication appears (%), and execution of the format starts.

When formatting is completed, the message “Format USB Memory Done” is displayed. The \MSSONY\PRO\XDCAM\MEMDISC folder and the \General\Sony\Planning folder are automatically created in the drive.

Notes

- All data is erased when you format a USB flash drive, including setup files and all of the recorded video data.
- Use the format function of this camcorder to format USB flash drives for use on this camcorder. The formats of drives formatted on other devices are not recognized as valid formats, making it necessary to format them again on this camcorder.

Restoring USB Flash Drives

When you load a USB flash drive that can be mounted normally because the file system is destroyed, a message appears on the viewfinder screen to ask whether you want to restore it. Pressing the MENU knob after turning the MENU knob to select “Execute” starts execution of the format and a progress indication appears (%).

When formatting is completed, the message “Format USB Memory Done” is displayed.

Basic Operations

This section explains the basic shooting and recording procedures.

Before starting to shoot, inspect the camera system to verify that it is operating properly.

- 1 Attach a fully charged battery pack** (*see page 35*).
- 2 Select the recording mode** (*see page 53*).
- 3 Load one or two SxS memory cards** (*see page 69*).
If you load two cards, the camcorder switches automatically to the second card when the first card becomes full.
- 4 Set the camcorder’s POWER switch** (*see page 15*) to ON.
- 5 Make the following settings.**
Marker display: On (*see page 118*)
Iris: Auto (*see page 59*)
Zoom: Auto
Camera output: Select the picture currently being shot (camera picture), and turn the DCC function on (*see page 19*).
Timecode advance mode: F-RUN (Free Run) or R-RUN (Rec Run) (*see page 62*)
Audio input channel selection: Auto (*see page 26*)
- 6 Push the AUTO W/B BAL switch to the BLACK side to adjust the black balance** (*see page 54*).
- 7 Select a filter according to the lighting conditions, and adjust the white balance** (*see page 55*).
- 8 Point the camcorder at the subject, and adjust the focus and zoom.**
- 9 If you are using the electronic shutter, select an appropriate shutter mode and speed** (*see page 57*).

10 Do one of the following to start recording.

- Press the REC START button (see page 17).
- Press the VTR button on the lens.
- Turn on the assignable switch to which the Rec function has been assigned (see page 156).

During recording, the TALLY indicators, the tally indicator on the front panel of the viewfinder, and the REC indication on the viewfinder screen light. Adjust the zoom and focus as required.

Notes

- Never remove the battery pack while the camcorder is recording (while the ACCESS lamp on the right-side panel is lit in blue and the ACCESS lamp in the card slot section is lit in orange). Doing so risks the loss of several seconds of data before the recording was interrupted, because internal processing will not end normally.
- The playback control buttons (EJECT, F REV, F FWD, NEXT, PREV, PLAY/PAUSE, STOP) do not function during recording.

11 To stop recording, perform one of the operations listed in step 10.

The TALLY indicators, the tally indicator on the front panel of the viewfinder, and the REC indication on the viewfinder screen go out, and camcorder enters recording standby (STBY) mode.

A clip is created from the video and audio data and the metadata recorded between steps 10 and 11.

Note

When the recording mode is UDF, if you stop recording within two seconds of starting, recording continues and this results in a two-second clip.

To check the recording (recording review)

With the camcorder in recording standby (STBY) mode, turn on the assignable switch to which the Rec Review function or the Freeze Mix function has been assigned (see page 155).

The camcorder plays the entire last clip, or the last few seconds of that clip (three seconds or 10 seconds), and then returns to standby mode.

You can use MAINTENANCE >Camera Config >Rec Review in the setup menu (see page 142) to change the playback time. When the Rec Review function is assigned to the RET button on the lens, you can also conduct a review by using the RET button.

12 Repeat steps 10 and 11 to continue recording.

With each repetition, another clip is created on the memory card.

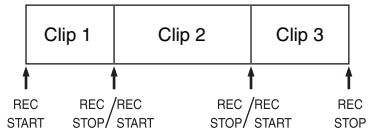

Notes

- You cannot resume recording for about one second after stopping recording.
- The maximum number of clips that can be recorded on one memory card is 600. Even if the memory card has enough free capacity to record more clips, when 600 clips have been recorded, no further recording is possible.

Clip file sizes

Clip file sizes vary according to file formats.

File format	File size	Clip size
MP4	Less than 4 GB	Less than half an hour
AVI	Less than 2 GB	Less than 9 minutes and 30 seconds
MXF	Less than 43 GB	Less than 6 hours

If you continue recording for an extended period, recorded materials may be segmented into multiple files, depending on the file size (the maximum number of partitions is 99).

The camcorder regards continuous recording as one clip even if it has been segmented into multiple files.

Clip names

Eight-character clips names (consisting of a four-character prefix and a four-digit number) are generated automatically for clips recorded by this camcorder.

Example: ABCD0001

You can also use OPERATION >Clip >Title Prefix (see page 126) in the setup menu to set the clip name prefix to a user-specified string of characters (four to 46 characters in length). (A

user-specified prefix cannot be changed after recording.)

The four-digit number at the end of clip names is generated automatically, counting up in order as clips are recorded.

Playing Recorded Clips

When the camcorder is in standby (STBY) mode, you can play all or part of the most recently recorded clip (*see page 75*).

- 1 Insert the SxS memory card to play (*see page 69*).**
- 2 Press the PREV button (*see page 21*) or the F REV button (*see page 21*) to cue up the clip to play.**
- 3 Press the PLAY/PAUSE button.**
The PLAY/PAUSE indicator lights, and the playback picture appears in the viewfinder.

To pause the playback

Press the PLAY/PAUSE button.

The PLAY/PAUSE indicator flashes during pause.

Press the button again to return to playback mode.

To play at high speed

Press the F FWD button (*see page 21*) or the F REV button (*see page 21*).

To return to normal playback, press the PLAY/PAUSE button.

To switch between memory cards

When two memory cards are loaded, press the SLOT SELECT button (*see page 25*) to select the active slot.

It is not possible to switch between memory cards during playback.

To end playback

Press the STOP button: Playback stops, and the camcorder enters E-E mode.

Press the THUMBNAIL button: Playback stops, and a thumbnail screen (*see page 91*) appears in the viewfinder.

Playback also stops and the timecode screen appears in the viewfinder when you start recording during playback, and when you eject an SxS memory card.

To display the camera picture during play (Live & Play function)

Live & Play is a function that allows you to display the camera picture (live video) on the viewfinder screen during play.

This allows you to frame the next scene or adjust the focus and exposure while checking the camera picture (live video) on the viewfinder screen. To frame the next scene, you can use this function together with the Freeze Mix function (*see page 84*).

The Live & Play function is enabled when the camcorder is set up as follows.

HD/SD	Number of system lines	System frequency
HD	1080	1920/59.94i
		1920/50i
	720	1440/59.94i
		1440/50i
SD	-	1280/59.94P
		1280/50P
		59.94i
		50i
		59.94i
		50i

To use the Live & Play function, set OPERATION >Output >Live&Play in the setup menu to [On].

Notes

- The Live & Play function cannot be turned on and off during playback or during thumbnail display.
- The Live & Play function cannot be used in Frame Rec, Interval Rec, and Slow & Quick Motion modes, and when the Slow Shutter function is enabled.
- To use the Live & Play function together with the Freeze Mix function, start by operating while viewing the LCD monitor (with the DISP SEL/EXPAND button pressed to set the display mode other than STATUS). When the operation finishes and the Freeze Mix function is activated, the same picture appears on the viewfinder screen.
- The play picture cannot be switched to the camera picture when playing a clip that was recorded with a number of system lines or a system frequency that differs from the current settings of this camcorder.
- The output from the HD/SD SDI OUT connector and the VIDEO OUT connector may freeze momentarily when the output is switched between the play picture and the camera picture.

Deleting Recorded Clips

You can use the assignable switches to delete the last recorded clips (Last Clip DEL function).

You can also use the THUMBNAIL menu to delete all recorded clips (All Clips DEL function) or to delete selected clips. For details, see “Deleting Clips” (page 103).

- 1 **Turn on the assignable switch to which the Last Clip DEL function has been assigned (see page 156).**
A confirmation message appears.
- 2 **Turn the MENU knob to select [Execute], and then press the knob.**

Advanced Operations

Recording Shot Marks

UDF / **FAT-HD**

On this camcorder, two types of shot marks are available in HD mode. You can record them at user-specified positions to make it easier for editors to cue up those positions.

The maximum numbers of shot marks per clip vary according to file formats.

File format	Maximum number
MP4	127
MXF	999

Note

Shot marks cannot be recorded in SD mode.

You can also use the THUMBNAIL menu to add and delete shot marks in clips. For details, see “Adding and Deleting Shot Marks” (page 106).

To record shot marks

Do one of the following.

- Turn on an assignable switch to which Shot Mark 1 or Shot Mark 2 has been assigned (see page 155).
- If Lens RET has been assigned to the RET button on the lens, operate as follows.

To record shot mark 1: Press the RET button once.

To record shot mark 2: Press the RET button twice in quick succession.

When a shot mark is recorded, a “Shot Mark 1” or “Shot Mark 2” indication appears in the viewfinder for about three seconds near the timecode indication.

Setting OK Marks

UDF / **FAT-HD**

To make it easier for editors to select good clips, you can set OK marks in clips recorded in HD mode.

Note

OK marks cannot be set or deleted during recording or playback.

To add/delete OK marks

You can use the THUMBNAIL menu to add and delete OK marks in previously recorded clips. For details, see “*Adding and Deleting OK, NG or KP Marks*” (page 101).

Starting to Record from Pre-stored Video (Picture Cache Function)

The camcorder is equipped with enough internal memory to pre-store up to 15 seconds of video and audio data in a picture cache. This allows you to begin recording a specified number of seconds in advance of the time when you press a recording start button.

Selecting picture cache mode and setting the picture cache time

Before recording in picture cache mode, you must select picture cache mode and set the picture cache time (the number of seconds of video and audio data stored to memory) in the OPERATION menu.

The picture cache time determines how far in advance you can start recording, counting back in seconds from the operation that starts recording. Note that it may not be possible to start this far in advance in the special cases explained in the following notes.

Notes

- Storage of picture data to memory begins when you select picture cache mode. Therefore, if you start recording immediately after selecting picture cache mode, the picture data from before the selection is not recorded.
- No data is recorded to picture cache memory during playback or recording review and display of

thumbnails. It is not possible to record picture data from the time you were conducting playback or a recording review.

To select picture cache mode and set the picture cache time

Notes

- Picture cache recording is not possible in Frame Rec, Interval Rec, Slow & Quick Motion, and Clip Continuous Rec mode. The camcorder exits Frame Rec, Interval Rec, Slow & Quick Motion or Clip Continuous Rec mode, whenever you select picture cache mode. The camcorder exits picture cache mode automatically whenever you select Frame Rec, Interval Rec, Slow & Quick Motion, or Clip Continuous Rec mode.
- The data stored in picture cache memory is cleared when you change the system settings, for example by selecting a different video format. Picture data from before the change is not recorded even if you start recording immediately after the change. The camcorder exits picture cache mode automatically.
- It is not possible to set the picture cache time during recording.

1 In the setup menu, select OPERATION >Rec Function >Picture Cache Rec.

For menu operations, see “*Basic Setup Menu Operations*” (page 109).

2 Turn the MENU knob to select [On], and then press the knob.

3 Select [P. Cache Rec Time], turn the MENU knob to select the desired picture cache time, and then press the knob.

You can select from 0-2sec, 2-4sec, 4-6sec, 6-8sec, 8-10sec, 10-12sec, 12-14sec, and 13-15sec.

Once made, picture cache mode settings remain in effect until changed.

Instead of carrying out steps 1 and 2, you can also select picture cache mode by using an assignable switch to which the Picture Cache function has been assigned (see page 155).

Camcorder data handling while recording in picture cache mode

Recording procedures in picture cache mode are basically the same as normal recording procedures. However, note the following differences with respect to how the camcorder handles video, time, and output data.

- If you start recording while the media is being accessed, the start point of the video that is actually recorded may be later than the currently specified picture cache time. Because the delay increases as the number of recorded clips increases, you should avoid rapid start-and-stop recording operations in picture cache mode.
- Regardless of the setting of the F-RUN/SET/R-RUN switch, the advance mode of the internal timecode generator is always F-RUN.
- In picture cache mode, you cannot set time data by setting the F-RUN/SET/R-RUN switch to SET.
To set time data, exit picture cache mode.
- If the remaining free capacity of the media in the currently selected slot is less than the picture cache time, and the media in the other slot has enough remaining capacity, then data is recorded to the media in the other slot. However, no data is recorded when there is no media in the other slot, and when the media in the other slot does not have enough remaining capacity. (A message appears in the viewfinder to inform you that there is not enough remaining capacity.)
- Shot marks are not recorded if they are set before the recording start operation.
- When you select a video format that supports i.LINK HDV output and play a clip that was recorded in picture cache mode, two or more frames with the same picture and timecode may follow on each other.
- i.LINK output is possible during picture cache recording. However, the picture cache time is limited.

If power is lost during recording

- If you set the camcorder's POWER switch to OFF, the camcorder is powered off automatically after a few seconds, during which the media is accessed to record the video and audio data stored in the camcorder's memory up to that point.
- If power is lost because the battery was removed, the DC cable was disconnected, or the power was turned off on the AC adaptor side, then the video and audio data stored in memory is lost. The data stored in memory is not recorded. Be careful to avoid this when exchanging the battery.

Recording Time-lapse Video (Interval Rec Function)

The camcorder's Interval Rec function allows you to capture time-lapse video to the camcorder's internal memory. This function is an effective way to shoot slow-moving subjects. When you start recording, the camcorder automatically records a specified number of frames at a specified interval time.

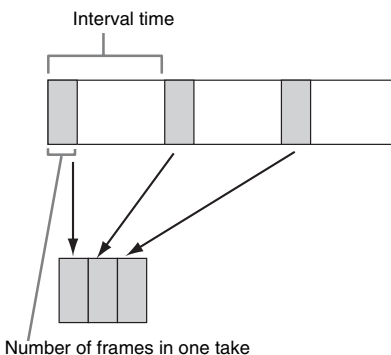

A pre-lighting function is available when Interval Rec is enabled. This function automatically turns on a video light before recording starts, which allows you to record pictures under stable light and color temperature conditions.

Interval Rec settings and shooting

Notes

- The Interval Rec function cannot be used at the same time as the picture cache, Frame Rec, Slow & Quick Motion, or Clip Continuous Rec function. When you select Interval Rec mode, the picture cache, Frame Rec, Slow & Quick Motion, and Clip Continuous Rec functions are disabled. When you select picture cache, Frame Rec, Slow & Quick Motion, or Clip Continuous Rec mode, the Interval Rec function is disabled.
- The data stored in picture cache memory is cleared when you change the system settings, for example by selecting a different video format. Picture data from before the change is not recorded even if you start recording immediately after the change. The camcorder exits picture cache mode automatically.
- Interval Rec settings cannot be changed during recording.
- Interval Rec is disabled when the following formats are selected.
 - In FAT mode, SP 1440/59.94i or SP 1440/50i, when the output setting is HD and OPERATION >Input/

Output >i.LINK I/O in the setup menu is set to [Enable]

- In FAT mode, SP 1440/23.98P (pull-down recording)
- In UDF mode, HD420 HQ 1280×720/23.98P (pull-down recording)
- Other than HQ 1920/23.98P or HQ 1280/23.98P, when the output setting is SD and OPERATION >Input/Output >i.LINK I/O in the setup menu is set to [Enable]

To make Interval Rec settings

1 Select OPERATION >Rec Function >Interval Rec in the setup menu.

For menu operations, see “Basic Setup Menu Operations” (page 109).

2 Turn the MENU knob to select [On], and then press the knob.

The camcorder enters Interval Rec mode, the “Interval” indication on the viewfinder screen flashes.
(The green tally indicator in the HDVF series viewfinder also flashes.)

3 Select [Number of Frames], turn the MENU knob to select the number of frames to record in one take, and then press the knob.

You can select from 1, 3, 6, 9 (or from 2, 6, 12 when the video format setting is 720/59.94P or 720/50P).

4 Select [Interval Time], turn the MENU knob to select the desired interval, and then press the knob.

You can select 1 to 10/15/20/30/40/50 sec, 1 to 10/15/20/30/40/50 min, 1 to 4/6/12/24 hour.

5 As required, select [Pre-Lighting], turn the MENU knob to select the length of lighting time before recording starts, and then press the knob.

You can select 1 to 10/15/20/30/40/50 sec, 1 to 10/15/20/30/40/50 min, 1 to 4/6/12/24 hour.

Notes

- If you want to turn the video light on before the start of recording, set the camcorder’s LIGHT switch to [AUTO]. The video light’s switch must also be turned on. When this is done, the video light turns on and off

automatically. However, the video light remains lit when the time that it is off is five seconds or less.

- If you set the LIGHT switch to [MANUAL] and turn the video light’s switch on, the video light is always lit. (It does not go on and off automatically.)

The camcorder exits Interval Rec mode when it is powered off, but the number of frames, interval time, and pre-lighting settings are maintained. You do not need to set them again the next time you shoot in Interval Rec mode.

To shoot in Interval Rec mode

Make the settings and preparations described in “Basic Operations” (page 74), secure the camcorder so that it does not move, and begin shooting.

When recording starts, the “Interval” indication in the viewfinder changes from flashing to lit, and “INT REC” and “INT STBY” appear alternatively at the position of the REC indication. The TALLY indicators and the tally indicator on the front panel of the viewfinder light as they do during normal recording. (The green tally indicator in the viewfinder flashes at high frequencies.)

If you are using the pre-lighting function, the video light comes on before recording starts.

To stop shooting

Stop the recording.

When shooting ends, the video data stored in memory up to that point is written to the media.

To exit Interval Rec mode

Do one of the following.

- Set the POWER switch to OFF.
- With the camcorder in recording standby mode, set OPERATION >Rec Function >Interval Rec in the setup menu to “Off”.

Limitations during recording

- The i.LINK (HDV/DV) connector cannot be used.
- Regardless of the setting of the F-RUN/SET/R-RUN switch, the advance mode of the internal timecode generator is always F-RUN.
- Audio cannot be recorded.
- Recording review is not possible.
- If you press the SLOT SELECT button, the camcorder completes recording of the specified number of frames, creates a clip, and switches

to the other media. (when the recording mode is UDF)

- Genlock is not possible.

If power is lost during recording

- If you set the camcorder's POWER switch to OFF, the camcorder is powered off automatically after a few seconds, during which the media is accessed to record the video and audio data stored in the camcorder's memory up to that point.
- If power is lost because the battery was removed, the DC power cord was disconnected, or the power was turned off on the AC adaptor side, then the video and audio data shot up to that point may be lost (maximum 10 seconds). Be careful to avoid this when exchanging the battery.

Shooting Stop Motion Animations (Frame Rec Function)

The Frame Rec function is useful for shooting stop motion animations, such as animations with puppets or clay figures.

Each time that you press the recording start button, the camcorder shoots a specified number of frames and then stops.

Frame Rec settings and shooting

Notes

- The Frame Rec function cannot be used at the same time as the picture cache, Interval Rec, Slow & Quick Motion, or Clip Continuous Rec function. When you select Frame Rec mode, the picture cache, Interval Rec, Slow & Quick Motion, and Clip Continuous Rec functions are disabled. When you select picture cache, Interval Rec, Slow & Quick Motion, or Clip Continuous Rec mode, the Frame Rec function is disabled.
- The data stored in memory is cleared when you change the system settings, for example by selecting a different video format. Picture data from before the change is not recorded even if you start recording immediately after the change. The camcorder exits Frame Rec mode automatically.
- Frame Rec settings cannot be changed during recording.
- Frame Rec is disabled when the following formats are selected.
 - In FAT mode, SP 1440/59.94i or SP 1440/50i, when the output setting is HD and OPERATION >Input/

Output >i.LINK I/O in the setup menu is set to Enable

- In FAT mode, SP 1440/23.98P (pull-down recording)
- In UDF mode, HD420 HQ 1280×720/23.98P (pull-down recording)
- Other than HQ 1920/23.98P or HQ 1280/23.98P, when the output setting is SD and OPERATION >Input/Output >i.LINK I/O in the setup menu is set to Enable

To make Frame Rec settings

1 Select OPERATION >Rec Function >Frame Rec in the setup menu.

For menu operations, see "Basic Setup Menu Operations" (page 109).

2 Turn the MENU knob to select [On], and then press the knob.

The camcorder enters Frame Rec mode, the "Frame Rec" indication on the viewfinder screen flashes.

(The green tally indicator in the HDVF series viewfinder also flashes.)

3 Select [Number of Frames], turn the MENU knob to select the number of frames to record in one take, and then press the knob.

You can select from 1, 3, 6, 9 (or from 2, 6, 12 when the video format setting is 720/59.94P or 720/50P).

The camcorder exits Frame Rec mode when it is powered off, but the setting for the number of frames setting is maintained. You do not need to set it again the next time you shoot in Frame Rec mode.

To shoot in Frame Rec mode

Make the settings and preparations described in "Basic Operations" (page 74), secure the camcorder so that it does not move, and begin shooting.

When recording starts, the "Frame Rec" indication in the viewfinder changes from flashing to lit, and "FRM REC" and "FRM STBY" appear alternatively at the position of the REC indication. The TALLY indicators and the tally indicator on the front panel of the viewfinder light as they do during normal recording.

To stop shooting

Stop the recording.

When shooting ends, the video data stored in memory up to that point is written to the media.

To exit Interval Rec mode

Do one of the following.

- Set the POWER switch to OFF
- With the camcorder in recording standby mode, set OPERATION >Rec Function >Interval Rec in the setup menu to “Off”.

Limitations during recording

- The i.LINK (HDV/DV) connector cannot be used.
- Regardless of the setting of the F-RUN/SET/R-RUN switch, the advance mode of the internal timecode generator is always R-RUN.
- Audio cannot be recorded.
- Recording review is not possible.
- If you press the SLOT SELECT button, the camcorder completes recording of the specified number of frames, creates a clip, and switches to the other media.
- Genlock is not possible.

If power is lost during recording

- If you set the camcorder’s POWER switch to OFF, the camcorder is powered off automatically after a few seconds, during which the media is accessed to record the video and audio data stored in the camcorder’s memory up to that point.
- If power is lost because the battery was removed, the DC power cord was disconnected, or the power was turned off on the AC adaptor side, then the video and audio data shot up to that point may be lost (maximum 10 seconds). Be careful to avoid this when exchanging the battery.

Shooting with Slow & Quick Motion

When the camcorder is in HD mode and the video format (*see page 51*) is set to one of the formats listed below, you can specify a recording frame rate that is different from the playback frame rate.

OPERATION >Format menu settings			Video format
Country	File System	HD System Line	
NTSC Area or NTSC(J) Area	UDF	1080	HD422 50/29.97P HD422 50/23.98P
		720	HD422 50/59.94P HD422 50/29.97P HD422 50/23.98P
	FAT	1080	HQ 1920/29.97P HQ 1920/23.98P
		720	HQ 1280/59.94P HQ 1280/29.97P HQ 1280/23.98P
PAL Area	UDF	1080	HD422 50/25P HD422 50/25P HD422 50/50P
		720	HQ 1920/25P HQ 1280/50P HQ 1280/25P
	FAT	1080	HQ 1920/25P
		720	HQ 1280/50P HQ 1280/25P

By shooting with a frame rate that differs from the playback frame rate, you can obtain slow and quick motion effects that are smoother than low-speed or high-speed playback of content recorded at the normal frame rate.

Example

When the video format is HQ 1280/23.98P, you can obtain quick-motion effects by setting the frame rate to 1 to 23, and obtain slow-motion effects by setting the frame rate to 25 to 60.

Slow & Quick Motion settings and shooting

Notes

- The Slow & Quick Motion function cannot be used at the same time as the picture cache, Interval Rec, Frame Rec, or Clip Continuous Rec function. When you select Slow & Quick Motion mode, the picture cache, Interval Rec, Frame Rec, and Clip Continuous Rec functions are disabled. When you select picture cache, Frame Rec, Interval Rec, or Clip Continuous Rec mode, the Slow & Quick Motion function is disabled.
- Slow & Quick Motion is disabled when the slow shutter function (viewfinder display “SLS”) function is enabled. The slow shutter function is disabled when the Slow & Quick Motion function is enabled.
- Slow & Quick Motion is disabled when OPERATION >Input/Output >i.LINK I/O in the setup menu is set to [Enable]. When Slow & Quick Motion is enabled, i.LINK I/O is fixed as [Disable].

- Slow & Quick Motion settings cannot be changed during recording.

To make Slow & Quick Motion settings

1 Select OPERATION >Rec Function > Slow & Quick in the setup menu.

For menu operations, see “Basic Setup Menu Operations” (page 109).

2 Turn the MENU knob to select [On], and then press the knob.

The camcorder enters Slow & Quick Motion mode, and the “S&Q STBY” indication in the viewfinder lights.

3 Select [Frame Rate], turn the MENU knob to select the recording frame rate, and then press the knob.

The setting range for the frame rate is as follows.

System lines	Frame rate
1080	When OPERATION >Format >Country in the setup menu is set to [PAL Area] in UDF mode: 1 to 25 In FAT mode or when OPERATION >Format >Country in the setup menu is set to other than [PAL Area] in UDF mode: 1 to 30
720	When OPERATION >Format >Country in the setup menu is set to [PAL Area] in UDF mode: 1 to 50 In FAT mode or when OPERATION >Format >Country in the setup menu is set to other than [PAL Area] in UDF mode: 1 to 60

When you finish making these settings, the system frequency and the frame rate appear at the top of the viewfinder screen. You can change the frame rate while viewing the display in the viewfinder by turning the MENU knob. The Slow & Quick Motion mode setting and the frame rate are retained even after the camcorder is powered off.

To shoot in Slow & Quick Motion mode

Shoot as described in “Basic Operations” (page 74).

When recording starts, the “S&Q STBY” indication in the viewfinder changes to the “●S&Q REC” indication. The TALLY indicators and the tally indicator on the front panel of the viewfinder light as they do during normal recording.

To stop shooting

Stop the recording.

Note

It takes longer than normal for recording to stop when Frame Rate is set to a low value (for a slow frame rate).

To exit Slow & Quick Motion mode

With the camcorder in recording standby mode, set OPERATION >Rec Function > Slow & Quick in the setup menu to [Off].

Limitations during recording

- The i.LINK (HDV/DV) connector cannot be used.
- Regardless of the setting of the F-RUN/SET/R-RUN switch, the advance mode of the internal timecode generator is always R-RUN.
- Audio cannot be recorded when the recording and playback frame rates differ.
- Recording review is not possible.
- If you change the recording frame rate to a value faster than the current shutter speed, the shutter speed is changed to the slowest value for which shooting is possible.
Example: If the frame rate is 32 and the shutter speed is $\frac{1}{40}$, and you change the frame rate to 55, then the shutter speed is changed to $\frac{1}{60}$. If it is not possible to select a shutter speed that is slower than the recording frame rate.
- Genlock is not possible.

Recording with the Clip Continuous Rec Function

Normally, a clip is created as an independent file each time that you start and stop recording. But this function allows you to start and stop recording while continuously recording to the same clip, for as long as the function remains enabled. This is convenient when you do not want to generate a large number of short clips, and when you want to record without worrying about exceeding the clip limit. It is still easy to find recording start points, because a Rec Start essence mark is recorded at the recording start point each time you start recording.

Clip Continuous Rec settings and shooting

Notes

- The Clip Continuous Rec function cannot be used at the same time as the Picture Cache, Interval Rec, Frame Rec, or Slow & Quick Motion function. When you select Clip Continuous Rec mode, the Picture Cache, Interval Rec, Frame Rec, and Slow & Quick Motion functions are disabled. When you select picture cache, Frame Rec, Interval Rec, or Slow & Quick Motion mode, the Clip Continuous Rec function is disabled.
- The Clip Continuous Rec function is disabled when the recording mode is FAT.

To make Clip Continuous Rec settings

1 Select OPERATION >Rec Function >Clip Continuous Rec in the setup menu.

See “Basic Setup Menu Operations” (page 109) for more information about menu operations.

2 Turn the MENU knob to select [On], and then press the knob.

“CONT” appears in the viewfinder, and the function is enabled.

You can assign the Clip Continuous Rec on/off function to one of the ASSIGN 1/2/3 switches, ASSIGNABLE 4/5 switches, and the COLOR TEMP button.

For details, see “Assigning Functions to Assignable Switches” (page 155).

To shoot in Clip Continuous Rec mode

Shoot as described in “Basic Operations” (page 74).

When recording starts, the “Cont” indication in the viewfinder changes to “●REC” indication. The TALLY indicators and the tally indicator on the front panel of the viewfinder light as they do during normal recording.

Note

During recording or in recording standby mode (when “Cont” indication is lit), if you remove the media, the battery, or the power source, the media needs to be restored. It is not possible to restore media on a device other than this camcorder.

Exit Clip Continuous Rec mode (see page 84) and then remove the media.

When “Cont” indication is flashing (at 1 flash/s), you can remove the media.

To stop shooting

Stop the recording.

Note

Stop the recording after the recording continues for two or more seconds.

To exit Clip Continuous Rec mode

With the camcorder in recording standby mode, set OPERATION >Rec Function >Clip Continuous Rec in the setup menu to [Off].

Limitations during recording

A single continuous clip cannot be created if you perform one of the following operations while the camcorder is in recording or recording standby mode (A new clip will be created when you next start recording.)

- Operate on a clip (lock, delete, or rename a clip)
- Change the recording format
- Turn off the POWER switch
- Playback
- Switched to thumbnail mode

Framing Shots with the Freeze Mix Function

The freeze mix function allows you to temporarily overlap a still image (freeze picture) from a clip shot in HD mode onto the current camera picture. This makes it easier to frame the shot.

Note

The freeze mix function is not available in the following cases.

- When the recording format is SP 1080/23.98P (FAT mode) or HQ 1280/23.98P (UDF mode)
- When the video formats of the recorded picture and the camera picture differ
- When you are shooting in Slow & Quick Motion mode or slow shutter mode
- When there is i.LINK input

To display a freeze mix picture

1 Play a clip or conduct a recording review of a clip with the same format as the camera picture.

2 Display the picture that you want to use as the frame, and then turn on the assignable switch to which the Freeze Mix function has been assigned.

The recording review picture is frozen and overlaps the camera picture.

Note

The following functions are disabled at the freeze mix times.

- Menu operations
- During Focus Mag display
- Marker display
- Zebra display
- Peaking display
- Skin tone details display

To cancel the freeze mix display

Do one of the following.

- Press an assignable switch again to which the Freeze Mix function has been assigned. The freeze mix display is canceled and the display returns to the normal camera picture.
- Start recording (*see page 75*). Normal recording starts.

Recording Proxy Data

UDF

Proxy data is made up of low-resolution video data (MPEG-4) and audio data (A-Low) (video: 1.5 Mbps; audio: 64 Kbps per channel). This lightweight proxy data can be used in the same way as the original data, but it can be transferred more quickly, for more efficient viewing and editing.

In UDF mode, proxy data is generated and recorded automatically when you record video and audio with a USB flash drive connected to the external device connector. By loading the proxy data from the USB flash drive into a computer, you can quickly check the recorded content or perform rapid offline editing.

Note

Do not power this unit off or do not remove the USB flash drive while the USB flash drive is being accessed. Doing so may cause the loss of all data recorded on the USB flash drive.

Recording Proxy Data While Recording Clips

You can record proxy data to a USB flash drive while recording clips to an SxS memory card.

- 1 Set MAINTENANCE >USB >Memory Rec in the setup menu to [Enable].**
- 2 Connect a USB flash drive formatted with the FAT32 file system to the external device connector (*see page 73*).**
- 3 Start recording.**

At the same time that the original data is recorded to an SxS memory card, proxy data is saved to the automatically generated \MSSONY\PROXD\CAM\MEMDISC\
<Proav-ID> folder (Proav-ID is an ID specified in the DISCMETA.XML file on the SxS memory card).

Proxy data: Saved in <Proav-ID>\Sub\

Metadata: Saved in <Proav-ID>\Clip\

To stop recording of proxy data

To stop recording of proxy data only, without stopping recording of original data, set MAINTENANCE >USB >Memory Rec in the setup menu to [Disable].

If recording fails

The message “USB Memory Error” appears. If recording fails because the USB flash drive is full, the message “USB Memory Full” appears. Proxy data is saved in this unit’s internal memory. If recording fails because of a USB flash drive defect or for some other reason, you can exchange the USB flash drive or reconnect it, and rerecord the proxy data saved in internal memory.

Recording Proxy Data for Existing Clips

You can record proxy data for clips on SxS memory cards to USB flash drives.

To record proxy data for all clips

- 1 Set MAINTENANCE >USB >Memory Rec in the setup menu to [Enable].
- 2 Connect a USB flash drive formatted with the FAT32 file system to the external device connector (see page 73).
- 3 Insert an SxS memory card with recorded clips.
- 4 Select MAINTENANCE >USB > Copy All Clips in the setup menu, and press the MENU knob.
- 5 Turn the MENU knob to select [Execute], and then press the knob. Recording of the proxy data starts. The message “Copy All Clips Done” appears when recording finishes.

To cue up a clip and record its proxy data

- 1 Set MAINTENANCE >USB >Memory Rec in the setup menu to [Enable].

- 2 Connect a USB flash drive formatted with the FAT32 file system to the external device connector (see page 73).
- 3 Insert an SxS memory card with recorded clips.
- 4 Cue up the clip for which you want to record proxy data.
- 5 Select MAINTENANCE >USB > Copy Current Clip in the setup menu, and press the MENU knob.
- 6 Turn the MENU knob to select [Execute], and then press the knob. Recording of the proxy data starts. The message “Copy Current Clip Done” appears when recording finishes.

Deleting All Proxy Data from a USB Flash Drive

You can delete all proxy data in the \MSSONY\PROXD\CAMMEMDISC folder by deleting the folder.

- 1 Set MAINTENANCE >USB >Memory Rec in the setup menu to [Enable].
- 2 Connect a USB flash drive containing proxy data to the external device connector.
- 3 Select MAINTENANCE >USB > Del All Memory Clips in the setup menu, and press the MENU knob.
- 4 Turn the MENU knob to select [Execute], and then press the knob. Deletion of the folder starts. The message “Delete All Clips Done” appears when the deletion finishes.

Planning Metadata Operations

Planning metadata is information about shooting and recording plans, recorded in an XML file.

```
<?xml:version="1.0" encoding="UTF-8"?>
<PlanningMetadata
xmlns="http://xmins.sony.net/pro/metadata/planningmetadata"
assignId="P0001" creationDate="2011-08-20T17:00:00+09:00"
lastUpdate="2011-09-28T10:30:00+09:00" load="false" version="1.00">
<PropertyssppropertyId="assignment" update="2011-09-20T09:00:00+09:00"
modifiedBy="Chris">
<TitlespusAscii="Typhoon" xml:lang="en">Typhoon_Strikes_Tokyo</Title>
</Properties>
</PlanningMetadata>
```

Example of a planning metadata file

You can shoot using clip names and shot mark names defined in advance in a planning metadata file.

This unit can display clip names and shot mark names defined in the following languages.

- English
- Chinese
- German
- French ¹⁾
- Italian
- Spanish
- Dutch ¹⁾
- Portuguese
- Swedish
- Norwegian
- Danish
- Finnish ¹⁾

1) Some characters are displayed as different but similar characters.

Note

If you define clip name and shot mark names in languages other than the above, they may not be displayed on the viewfinder screen or the LCD monitor screen (with the display mode set to STATUS). In the LCD monitor (with the display mode set to STATUS), only alphanumeric characters and symbols can be displayed.

Loading a Planning Metadata File into Camcorder's Internal Memory

To record planning metadata together with recording clips, you need to load a planning metadata file into the camcorder's memory before starting to shoot.

There are two ways to load files.

- Load a file that has been written to the following directories on an SxS memory card or a USB flash drive.

Recording mode	Media	Directory to which files are written
FAT	SxS memory card	BPAV/General/Sony/Planning
	SDHC	PRIVATE/SONY/BPAV/General/Sony/Planning
UDF	SxS memory card	General/Sony/Planning
	USB flash drive	

- When a Wi-Fi connection is made between the camcorder and a computer, operate the Web menu built in the camcorder from the computer to transfer a file.

For details on how to use the Web menu to load a planning metadata file, refer to the Supplement supplied in the CD-ROM (labeled "Manuals for Solid-State Memory Camcorder").

To load a planning metadata file by menu operation

Do the following procedures with OPERAION >Planning Metadata in the setup menu.

To load a file in an SxS memory card

- 1 **Insert an SxS memory card into the memory card slot A or B, and set Load/Slot(A) or Load/Slot(B) to [Execute].**
A file list appears.

Note

The file list displays up to 64 files. Even if the total number of planning metadata files is 64 or less, all of the planning metadata files may not appear if the directory where they are located on the SxS memory card (General/Sony/Planning) contains 512 or more files.

- 2 Turn the MENU knob to select a file to load and press the knob.

To load a file in a USB flash drive (in UDF mode)

- 1 Connect a USB flash drive formatted with the FAT32 file system to the external device connector (see page 73). A file list appears.

Note

The file list displays up to 64 files.

Even if the total number of planning metadata files is 64 or less, all of the planning metadata files may not appear if the directory where they are located on the USB flash driver (General/Sony/Planning) contains 512 or more files.

- 2 Turn the MENU knob to select a file to load and press the knob.

To display detailed information in planning metadata

After loading planning metadata into this unit, you can check the detailed information that it contains, such as file names, date and time of creation, and titles.

- 1 Under OPERATION >Plan.Metadata >Properties in the setup menu, select [Execute].
- 2 Turn the MENU knob to select [Execute], and then press the knob. The PLANNING METADATA PROPERTIES list appears. The list contains the following information.

Item	Information
File Name	File name
Assign ID	Assign ID
Created	Date and time of creation
Modified	Date and time of most recent modification
Modified by	Name of person who modified the file
Title	Title1 specified in file (ASCII format clip name)
Title2	Title2 specified in file (UTF-8 format clip name)
Material Gp	Number of clips in material group a)
Shot Mark0 to Shot Mark9	Names defined in file for Shot Mark 0 to Shot Mark 9

a) Material group: A group of clips recorded with the same planning metadata.

You can turn the MENU knob to scroll the list.

After turning the MENU knob to select an item, you can press the SET button to display the selected item only.

To clear the planning metadata loaded

- 1 Under OPERATION >Plan.Metadata >Clear in the setup menu, select [Execute].
- 2 Turn the MENU knob to select [Execute], and then press the knob. Deletion of the file starts. The message “Clear Planning Metadata File OK” appears when the deletion finishes.

Defining Clip Names in Planning Metadata

The following two types of clip name strings can be written in a planning metadata file.

- The ASCII format name that appears in the viewfinder
- The UTF-8 format name that is actually registered as the clip name

You can select which type of clip name is displayed with OPERAION >Planning Metadata >Clip Name Disp in the setup menu.

When a clip name is set with planning metadata, the name is displayed under the depth of field indication on the viewfinder screen.

Note

When you define both of ASCII format name and UTF-8 format name with planning metadata, the UTF-8 format string is used as the clip name string. If you define either of ASCII format name and UTF-8 format name with planning metadata, the defined format name is displayed though it is not selected by menu setting.

Clip name string example

Use a text editor to modify the two fields in the <Title> tag that contain the clip name strings. The shaded fields in the example are clip name strings. “Typhoon” is described in ASCII format (up to 44 characters). “Typhoon_Strikes_Tokyo” is described in UTF-8 format (up to 44 bytes). “sp” indicates a space and ↵ indicates a carriage return.

```
<?xmlspversion="1.0"spencoding="
UTF-8"?>↵
<PlanningMetadataspxmlns="http://
xmlns.sony.net/pro/metadata/
planningmetadata"spassignId="
P0001"spcreationDate="
2011-08-20T17:00:00+09:00"sp
lastUpdate="
2011-09-28T10:30:00+09:00"sp
version="1.00">↵
  <PropertiessppropertyId="
assignment"spupdate="
2011-09-28T10:30:00+09:00"sp
modifiedBy="Chris">↵
    <TitlespusAscii="Typhoon"sp
xml:lang="en"> Typhoon_Strikes_Tokyo
  </Title>↵
</Properties>↵
</PlanningMetadata>↵
```

Notes

- When you create a file, enter each statement as a single line with a CRLF only after the last character in the statement line, and do not enter spaces except where specified.
- Up to 44 bytes (or characters) string is available for the clip name.
If the UTF-8 format string exceeds 44 bytes, 44 bytes string is used as the clip name.
If only ASCII format name is specified, 44 characters string is used as the clip name.
When neither an ASCII format name string nor UTF-8

format name string can be used, the standard format clip name is used.

You can use the Sony Planning Metadata Add-in application software supplied with the CBK-WA01 Wi-Fi Adapter to define clip names. For details, refer to the Operating Instructions supplied with the CBK-WA01.

To set clip names

- 1 **Load a planning metadata file that contains clip names into this camcorder.**
- 2 **Set OPERATION >Clip >Auto Naming in the setup menu to [Plan].**

Each time that you record a clip, the unit automatically generates a name consisting of the clip name defined in the planning metadata file, with the addition of an underbar (_) and a five-digit serial number (00001 to 99999).

Examples:

```
Typhoon_Strikes_Tokyo_00001,
Typhoon_Strikes_Tokyo_00002, ...
```

Note

When you load another planning metadata file, the serial number returns to 00001 with the next recording operation.

To select the clip name display format

When names are defined in both ASCII format and UTF-8 format, you can use OPERATION >Clip >Clip Name Disp in the setup menu to select which of the names to display on the LCD monitor and on the viewfinder screen.

To display ASCII format names: Select

Title1(ASCII).

The clip name becomes

“Typhoon_Strikes_Tokyo_SerialNumber”, but “Typhoon_SerialNumber” is displayed on the screens.

To display UTF-8 format names: Select

Title2(UTF-8).

The clip name becomes

“Typhoon_Strikes_Tokyo_SerialNumber”, and the same name is displayed on the screens.

Defining Shot Mark Names in Planning Metadata

When you use planning metadata to set shot marks, you can define names for Shot Mark 0 to Shot Mark 9. When you record shot marks, you can add the shot mark name strings defined in the planning metadata.

Note

Shot Mark 1 and Shot Mark 2 can be recorded on the camcorder. Shot Mark 3 to Shot Mark 9 and Shot Mark 0 can be recorded by operation from a computer which is connected with the camcorder via Wi-Fi.

Shot mark name string example

Use a text editor to modify the fields in the <Meta name> tag.

The shaded fields in the example are essence mark name strings. Names can be either in ASCII format (up to 32 characters) or UTF-8 format (up to 16 characters).

“sp” indicates a space and ↵ indicates a carriage return.

Note

If a name string contains even one non-ASCII character, the maximum length of that string is 16 characters.

```
<?xmlspversion="1.0"spencoding="
UTF-8"?'>↵
<PlanningMetadata xmlns="http://
xmlns.sony.net/pro/metadata/
planningmetadata"spassignId="
H00123"spcreationDate="
2011-04-15T08:00:00Z"splastUpdate="
2011-04-15T15:00:00Z"spversion="
"1.00">↵
<PropertiessppropertyId=
"assignment"spclass="original"sp
update="2011-04-15T15:00:00Z"sp
modifiedBy="Chris">↵
  <TitlespusAscii="Football
Game"spxml:lang="en">
    Football Game 15/04/2011</
    Title>↵
    <Metaspname="_ShotMark1"sp
    content="Goal"/>↵
    <Metaspname="_ShotMark2"sp
    content="Shoot"/>↵
    <Metaspname="_ShotMark3"sp
    content="Corner Kick"/>↵
```

```
<Metaspname="_ShotMark4"sp
content="Free Kick"/>↵
<Metaspname="_ShotMark5"sp
content="Goal Kick"/>↵
<Metaspname="_ShotMark6"sp
content="Foul"/>↵
<Metaspname="_ShotMark7"sp
content="PK"/>↵
<Metaspname="_ShotMark8"sp
content="1st Half"/>↵
<Metaspname="_ShotMark9"sp
content="2nd Half"/>↵
<Metaspname="_ShotMark0"sp
content="Kick Off"/>↵
```

```
</Properties>↵
</PlanningMetadata>↵
```

Note

When you create a definition file, enter each statement as a single line with a CRLF only after the last character in the statement line, and do not enter spaces except where specified, except within essence mark name strings.

You can use the Sony Planning Metadata Add-in application software supplied with the CBK-WA01 Wi-Fi Adapter to Essence mark names. For details, refer to the Operating Instructions supplied with the CBK-WA01.

Clip Playback

A thumbnail screen appears if you press the THUMBNAIL button in E-E or playback mode. Thumbnail screens display lists of the clips stored on SxS memory cards in the form of index pictures. (A message appears if you insert a memory card that contains no clips.)

You can select any clip (*see page 94*) in a thumbnail screen and start playback of that clip (*see page 94*).

Thumbnail Screen

In thumbnail screens, the timecode of the index picture appears beneath the thumbnail for each clip. (An OK, NG or KP mark also appears when a clip has been marked with an OK, NG or KP mark.)

Note

Normal thumbnail screens display SD clips only or HD clips only, even if the SxS memory card contains clips in both formats. You can select the format to display by selecting a mode with OPERATION >Format >HD/SD (*see page 112*) in the setup menu.

If you want to display all recorded clips, regardless of the HD/SD mode, switch to the all clips thumbnail screen. However, it is not possible to start playback from the all clips thumbnail screen (*see page 99*).

UDF / FAT-HD

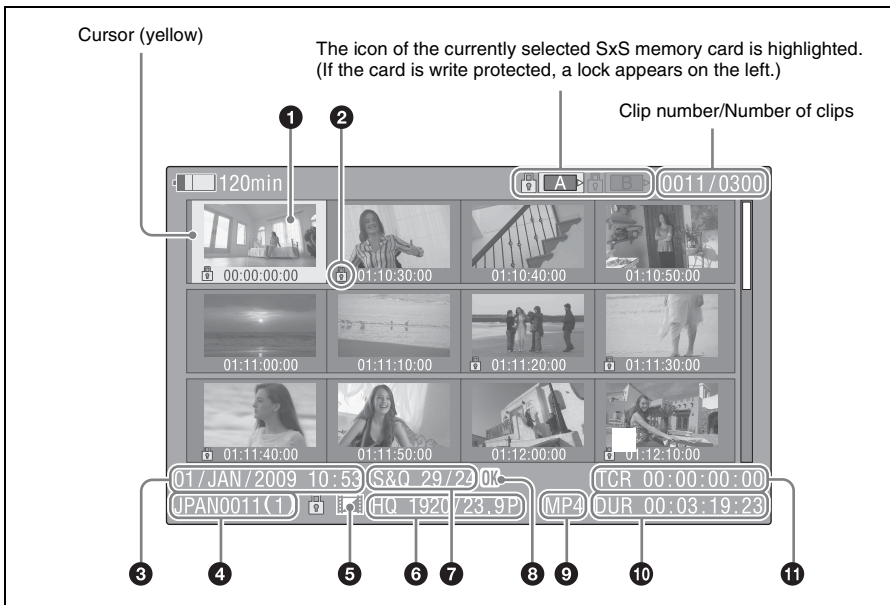

1 Index picture

When a clip is recorded, its first frame is set automatically as the index picture. You can change to index picture to any frame (see page 106).

2 Lock mark

Indicates the selected clip is marked with an OK mark or protected.

3 Date and start time of recording

4 Clip name

5 Independent AV file icon

This appears only when a clip is an independent AV file. SxS memory cards may contain independent files that have been added directly from a computer. Because independent files lack the associated management files, some operations and information displays may not be available.

6 Video format of recording

7 Special recording information

This displays the mode of clips that have been recorded in a special mode (Slow & Quick Motion, Interval Rec, Frame Rec).

For Slow & Quick Motion clips, the frame rates are displayed to the right as [Recording frame rate/Playback frame rate] fps.

8 OK/NG/KP mark

When the recording mode is UDF, an OK, NG, or KP mark appears if the clip has been marked with an OK, NG or KP mark (see page 101).

When the recording mode is FAT, an OK mark appears only if the clip has been marked with an OK mark (see page 101).

9 File format

Indicates the file format of the selected clip (MXF or MP4).

(This item is not indicated when the recording mode is UDF-HD mode.)

10 Clip duration**11 Timecode**

This is the timecode of the index picture.

FAT-SD mode thumbnail screen

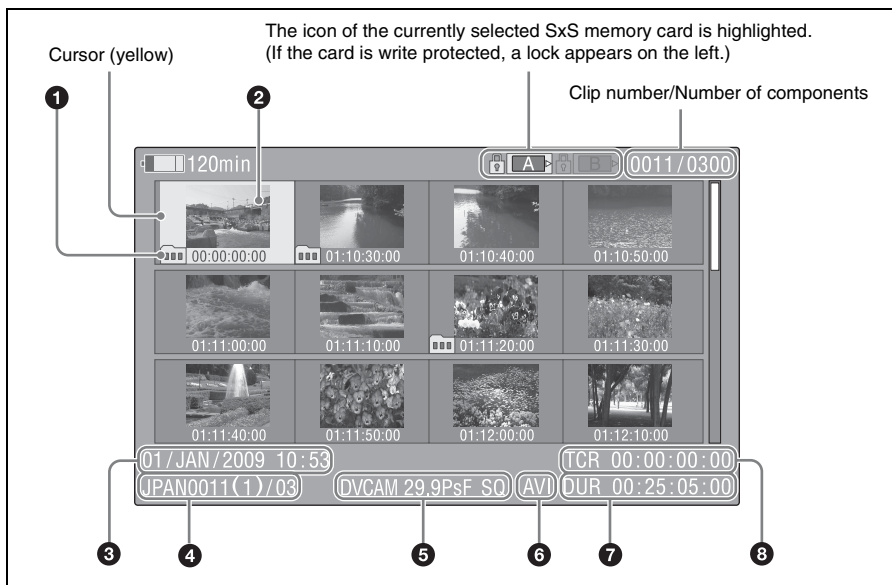
FAT-SD**1 Take mark**

Indicates that the file size is larger than 2 GB, and that the clip has been split before being saved. You can check the segment files on the expand thumbnail screen (see page 104).

2 Index picture

When a clip is recorded, its first frame is set automatically as the index picture.

3 Date and start time of recording**4 Clip name/Number of components**

The number after the clip name (delimited by /) is the number of components. This appears only for clips larger than 2 GB in size, which have been split into smaller files for storage.

5 Video format of recording**6 File format**

Indicates the file format of the selected clip (AVI).

7 Clip duration**8 Timecode**

This is the timecode of the index picture.

To switch between SxS memory cards

When two SxS memory cards are loaded, you can switch between them by pressing the SLOT SELECT button.

Note

While an expand thumbnail screen (see page 104) or an essence mark thumbnail screen (see page 105) is displayed, SxS memory cards cannot be switched.

To hide the thumbnail screen

Press the THUMBNAIL button.

Playing Clips

To select clip thumbnails

Do one of the following to move the yellow cursor to the clip that you want to select.

- Press an arrow button (↑, ↓, ←, →).
- Turn the MENU knob.
- Press the PREV or NEXT button.

To select the first thumbnail

With the F REV button held down, press the PREV button.

To select the last thumbnail

With the F FWD button held down, press the NEXT button.

To play clips sequentially starting from a selected clip

1 Select the thumbnail of the clip that you want to play first.

2 Press the PLAY/PAUSE button.
Play begins from the top of the selected clip.

Play continues through all clips after the selected clip.

When the last clip has been played to the end, the camcorder enters pause (still image) mode at the last frame of the last clip.

Press the THUMBNAIL button to return to the thumbnail screen.

Notes

- There may be momentary picture breakup or still image display at the transition from one clip to another. During this time, the play controls and the THUMBNAIL button cannot be operated.
- When you select a clip in the thumbnail screen and begin playback, there may be momentary picture breakup at the top of the clip. To view the top of the clip without breakup, put the camcorder into playback mode, pause, use the PREV button to return to the top of the clip, and start play again.
- On SxS memory cards that contain both HD-mode and SD-mode clips, you cannot play all clips in sequence. For example, while an HD mode thumbnail screen is displayed, only HD mode clips are played in sequence.

To pause play

Press the PLAY/PAUSE button.

The PLAY/PAUSE indicator flashes while play is paused.

Press the button again to return to play mode.

To play at high speed

Press the F FWD button (*see page 21*) or the F REV button (*see page 21*).

To return to normal playback, press the PLAY/PAUSE button.

To stop play

Press the STOP button: Play stops and the camcorder enters E-E mode.

Press the THUMBNAIL button: Play stops and the thumbnail screen (*see page 91*) appears in the viewfinder.

Play also stops if you eject the memory card. In this case, the camera picture appears in the viewfinder.

To cue up clips

To return to the top of the current clip

Press the PREV button.

- During playback or F FWD, this jumps to the top of the current clip and starts play.
- During F REV or pause, this jumps to the top of the current clip and displays a still image.
- Each subsequent press of the button moves to the previous clip.

To play from the top of the first clip

Simultaneously press the PREV and F REV buttons. This jumps to the top of the first clip on the SxS memory card.

To jump to the top of the next clip

Press the NEXT button.

- During playback or F FWD, this jumps to the top of the next clip and starts play.
- During F REV or pause, this jumps to the top of the next clip and displays a still image.
- Each subsequent press of the button moves to the next clip.

To play from the top of the last clip

Simultaneously press the NEXT and F FWD buttons. This jumps to the top of the last clip on the SxS memory card.

To add a shot mark during play

HD

You can add shot marks to clips during play by using the same method used during recording (see page 77).

Notes

- Shot marks cannot be recorded when the SxS memory card is write protected.
- Shot marks cannot be added at the first frame of each clip or last frame of the last clip.

Using Thumbnails to Search Inside Clips

You can switch a thumbnail screen to the following thumbnail search screens, which allow you quickly find the clips you want.

- Expand thumbnail screen
- Essence mark thumbnail screen (in HD mode only)

Like the normal thumbnail screen and the OK clip thumbnail screen, these screens allow you to select clip thumbnails (see page 94) and to start clip playback (see page 94).

To search for scenes in clips with the expand thumbnail screen

The expand thumbnail screen is convenient when you want to find and cue up a specific scene in a long clip.

To display the expand thumbnail screen, select a clip in the thumbnail screen and press the DISP SEL/EXPAND button (see page 21) or select THUMBNAIL >Thumbnail View >Forward Expansion in the setup menu. The selected clip is displayed as follows.

HD mode: The clip is divided into 12 equally-sized blocks, and a thumbnail of the first frame in each block is displayed.

SD mode: Only in the case of clips that have been split into partial files because the file size was larger than 2 GB, a thumbnail of the first frame of each partial file is displayed.

This helps you to quickly cue up to a desired scene in a clip of long duration.

See “Displaying the Expand Thumbnail Screen” (page 104) for more information about the expand thumbnail screen.

To search for essence marks in clips with the essence mark thumbnail screen

UDF / FAT-HD

When a clip contains one or more essence marks, you can easily find them with the essence mark thumbnail screen. The essence mark thumbnail screen displays a thumbnail of each essence mark frame in the clip.

To display the essence mark thumbnail screen, press the ESSENCE MARK button (see page 23) or select THUMBNAIL >Thumbnail View >Essence Mark Thumbnail in the setup menu.

See “Displaying the Essence Mark Thumbnail Screen” (page 105) for more information about the essence mark thumbnail screen.

Thumbnail Operations

You can use the THUMBNAIL menu to perform various operations on clips, to check clip properties, and to change clip metadata.

THUMBNAIL Menu Configuration

Menu items	Sub-items	Description
	Clip Properties	Displays detailed properties (<i>see page 100</i>).
	Set Index Picture	Changes index pictures in the expand thumbnail screen or the essence mark thumbnail screen (<i>see page 106</i>).
UDF / FAT-HD		
	Thumbnail View	
	Forward Expansion	<ul style="list-style-type: none"> • Displays the expand thumbnail screen (<i>see page 104</i>). • In the expand thumbnail screen, increases the number of divisions (<i>see page 105</i>).
	Back Expansion	In the expand thumbnail screen, decreases the number of divisions.
UDF / FAT-HD	Essence Mark Thumbnail	Displays the essence mark thumbnail screen (<i>see page 105</i>).
	Clip Thumbnail	Displays the normal thumbnail screen.
	All Clip Thumbnail	Displays the all clips thumbnail screen (<i>see page 99</i>).
	Set Shot Mark	
UDF / FAT-HD	Add Shot Mark1	In the expand thumbnail screen or the essence mark thumbnail screen, adds a Shot Mark1 mark (<i>see page 106</i>).
	Delete Shot Mark1	In the expand thumbnail screen or the essence mark thumbnail screen, deletes a Shot Mark1 mark (<i>see page 106</i>).
	Add Shot Mark2	In the expand thumbnail screen or the essence mark thumbnail screen, adds a Shot Mark2 mark (<i>see page 106</i>).
	Delete Shot Mark2	In the expand thumbnail screen or the essence mark thumbnail screen, deletes a Shot Mark2 mark (<i>see page 106</i>).
	Set Clip Flag	
UDF	OK	Adds an OK mark.
	NG	Adds an NG mark.
	KP(Keep)	Adds a KP mark.
	None	Deletes an OK, an NG or a KP mark.
	Add OK Mark	Adds an OK mark and protects a clip (<i>see page 101</i>).
FAT-HD		
	Delete OK Mark	Deletes an OK mark and unprotects a clip (<i>see page 101</i>).
FAT-HD		
	Lock Clip	Protects a clip.
UDF		
	Unlock Clip	Cancels protection of a clip.
UDF		

Menu items	Sub-items	Description
Copy Clip	—	Copies a clip (<i>see page 102</i>).
Delete Clip	—	Deletes a clip (<i>see page 103</i>).
Divide Clip	—	Divides a clip (<i>see page 106</i>).
FAT-HD		
Filter Clips	—	Displays the OK clip thumbnail screen (<i>see page 98</i>).
FAT-HD		
Filter Clips	OK	Displays the OK clip thumbnail screen.
UDF	NG	Displays the NG clip thumbnail screen.
	KP(Keep)	Displays the KP clip thumbnail screen.
	None	Displays the None clip (clip which have been marked with an OK, NG, or KP mark) thumbnail screen.
Lock All Clips	—	Protects all clips displayed.
UDF		
Unlock All Clips	—	Cancels protection of all clips displayed.
UDF		
Copy All	All Clips General Files All Clips & General Files	Batch copies groups of clips/files (<i>see page 103</i>).
Delete All Clips	Execute/Cancel	Deletes all unprotected clips (<i>see page 103</i>).

Basic THUMBNAIL Menu Operations

See “Basic Setup Menu Operations” (page 109) for information about menu operations.

To display the THUMBNAIL menu

- 1 Press the THUMBNAIL button to display the thumbnail screen.
- 2 Set the MENU ON/OFF switch to ON, or press the MENU button.
- 3 Turn the MENU knob to select “TH”, and then press the knob. Or press the \uparrow or \downarrow button to select “TH”, and then press the SET button.
The THUMBNAIL menu appears.

FAT



in FAT mode

UDF

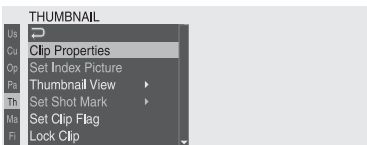

in UDF mode

To hide the THUMBNAIL menu, press the MENU button again.

To select menu items and sub-items

Do one of the following.

- Turn the MENU knob to select an item or sub-item, and then press the knob.
- Press the arrow buttons (\uparrow , \downarrow , \leftarrow , \rightarrow) to select an item or sub-item, and then press the SET button.

According to the selected item or sub-item, a selection list or a clip properties screen appears (see page 100).

To return to the previous state, push the MENU CANCEL/PRST/ESCAPE switch down to the ESCAPE side.

Notes

- When an SxS memory card is write protected, it is not possible to copy, delete, or divide clips, to change index pictures, or to add and delete OK/NG/KP marks and shot marks.
- Some items cannot be selected, depending on the state of the camcorder when the menu was displayed.

To hide the clip properties screen

Do one of the following.

Press the RESET/RETURN button: This returns to the THUMBNAIL menu.

Press the THUMBNAIL button: The camcorder enters E-E mode, and the camera picture appears.

Press the PLAY/PAUSE button: Playback from the selected clip starts.

Changing the Thumbnail Screen Type

To display OK/NG/KP/None clip thumbnails

When the recording mode is UDF, from among all clips stored on the currently selected SxS memory card, only clips which have been marked with a OK, NG or KP mark can be displayed, or only clips with no marks (None clips) can be displayed.

When the recording mode is FAT, from among all clips stored on the currently selected SxS memory card, only clips which have been marked with an OK mark can be displayed.

When the normal thumbnail screen is displayed, you can select THUMBNAIL >Filter Clips to switch to the screen.

In FAT-HD mode: Switched to the OK clip thumbnail screen.

In UDF mode: By selecting one of OK, NG, KP (Keep) and None in the setting area, you can display the thumbnail screen containing only clips which have been marked with the selected mark or only clips which have been marked with no marks (None clips).

See “Adding and Deleting OK, NG or KP Marks” (page 101) for information about how to add OK marks.

To display the all clips thumbnail screen

The all clips thumbnail screen displays thumbnails of all of the clips on the selected memory card, including both HD-mode and SD-mode clips. This is useful when you want to check whether the memory card contains clips in another mode.

You can switch to the all clips thumbnail screen by selecting THUMBNAIL >All Clip Thumbnail in the setup menu in the normal thumbnails screen.

Pressing the RESET/RETURN button returns you to the normal thumbnails screen, where you can perform playback and other clip operations.

Note

You cannot start playback from the all clips thumbnail screen.

Displaying Clip Properties

The clip properties screen appears when you select Clip Properties in the THUMBNAIL menu.

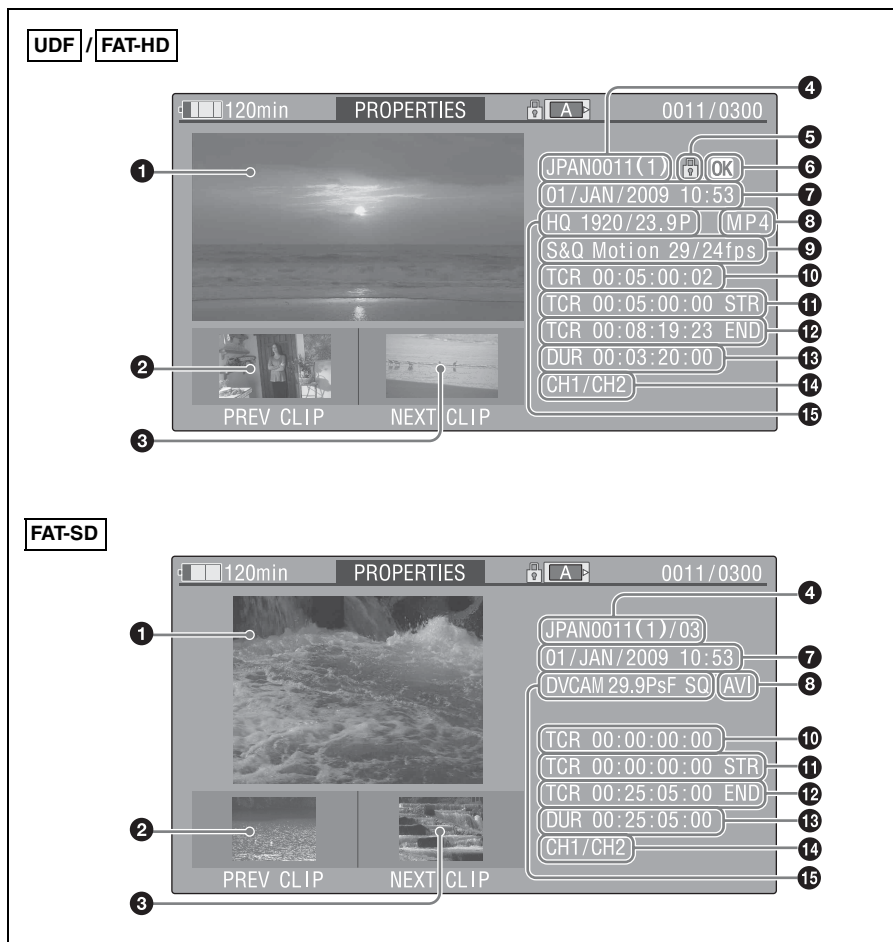

1 Image of the current clip

2 Image of the previous clip

Press the PREV button to display the properties of the previous clip.

3 Image of the next clip

Press the NEXT button to display the properties of the next clip.

4 Clip name

In SD mode, only for clips that have been divided because the file size was greater than 2 GB, the number of component clips appears after the clip name.

When clip names are 12 characters or longer, only the first five characters and the last five characters are displayed. If you want to check the abbreviated characters, press the MENU knob to switch to long display mode. In long display mode, up to 53 characters are displayed in clip names.

Press the MENU knob again to exit long display mode. Pressing the PREV or NEXT button to display the previous or next clip also exists long display mode.

5 Lock mark

This appears when the clip is marked with an OK mark or protected.

6 OK/NG/KP mark

This appears only when an OK/NG/KP mark has been added.

7 Date and start time of recording

8 File format

The file format of the clip (MXF, MP4 or AVI) appears.

9 Special recording information

This displays the mode of clips that have been recorded in a special mode (Slow & Quick Motion, Interval Rec, Frame Rec).

For Slow & Quick Motion clips, the frame rates are displayed to the right as [Recording frame rate/Playback frame rate].

10 Timecode of the displayed image

11 Timecode of the recording start point

12 Timecode of the recording end point

13 Duration

14 Recorded audio channels

15 Video format of recording

Adding and Deleting OK, NG or KP Marks

UDF / **FAT-HD**

You can add OK, NG or KP marks to clips. This makes it possible to display thumbnails of only the clips that you need by pressing the THUMBNAIL button.

When the recording mode is FAT, clips with OK marks cannot be deleted or divided (protected). If you want to delete or divide such a clip, delete the OK mark.

To add an OK mark

FAT-HD

1 In the thumbnail screen, select THUMBNAIL >Add OK Mark.

The screen changes to the clip properties screen, and a confirmation message appears beneath the index picture.

2 Select [Execute], and press the MENU knob.

An OK mark is added to the selected clip.

You can use an assignable switch to which Clip Flag OK is assigned to add OK marks.

To add an OK, NG or KP mark

UDF

1 In the thumbnail screen, select THUMBNAIL >Set Clip Flag.

2 Select one of OK, NG or KP in the setting area.

3 Select [Execute], and press the MENU knob.

The mark selected in step 2 is added to the selected clip.

You can use assignable switches to which Clip Flag OK, Clip Flag NG and Clip Flag Keep are assigned to add OK, NG and KP marks.

To delete an OK mark

FAT-HD

A Delete OK Mark item appears in the THUMBNAIL menu when you have selected a clip that has an OK mark.

1 In the thumbnail screen, select THUMBNAIL >Delete OK Mark.

The screen changes to the clip properties screen, and a confirmation message appears beneath the index picture.

2 Select [Execute], and press the MENU knob.

The OK mark is deleted from the selected clip.

To delete an OK, NG or KP mark

UDF

1 In the thumbnail screen, select the thumbnail of the clip from which you want to delete an OK, NG or KP mark, and select THUMBNAIL >Set Clip Flag >None.

The screen changes to the clip properties screen, and a confirmation message appears beneath the index picture.

2 Select [Execute], and press the MENU knob.

The mark selected in step 2 is added to the selected clip.

Protecting Clips

UDF

When the recording mode is UDF, you can protect a selected clip or all clips. Protected clips cannot be deleted or divided.

To protect a clip

1 In the thumbnail screen, select the thumbnail of the clip which you want to protect, and select THUMBNAIL >Lock Clip.

The screen changes to the clip properties screen, and a confirmation message appears beneath the index picture.

2 Select [Execute], and press the MENU knob.

The selected clip is protected.

To protect all clips

1 In the thumbnail screen, select THUMBNAIL >Lock All Clips.

A confirmation message appears beneath the index picture.

2 Select [Execute], and press the MENU knob.

All clips are protected.

To cancel protection of a clip

1 In the thumbnail screen, select the thumbnail of the clip which you want to unprotect, and select THUMBNAIL >Unlock Clip.

The screen changes to the clip properties screen, and a confirmation message appears beneath the index picture.

2 Select [Execute], and press the MENU knob.

The selected clip is unprotected.

To cancel protection of all clips

1 In the thumbnail screen, select THUMBNAIL >Unlock All Clip.

A confirmation message appears beneath the index picture.

2 Select [Execute], and press the MENU knob.

All clips are unprotected.

Copying Clips

You can copy clips to other SxS memory cards. Clips are copied to destination SxS memory cards using the same names as the original clips.

Notes

- If a clip with the same name already exists at the copy destination SxS memory card, a one-digit number in parentheses is added to the original name. The number in parentheses is the smallest number that does not exist at the copy destination.

Examples:

ABCD0002→ABCD0002(1)

ABCD0002(1)→ABCD0002(2)

ABCD0005(3)→ABCD0005(4)

- If the parenthetical numbers (1) to (9) already exist at the copy destination, it is not possible to copy any more clips under that name. (A tenth clip cannot be copied.)

- A message appears if there is not enough free capacity at the copy destination SxS memory card. Exchange the card for one with more free capacity.
- When multiple clips are recorded in a source SxS memory card, it may not be possible to copy all clips to the end. Depending on memory characteristics and usage of the memory cards, this can occur even when the source and destination memory cards have the same capacity.

1 In the thumbnail screen, select the thumbnail of the clip to copy, and then select THUMBNAIL >Copy Clip.

The screen changes to the properties screen of that clip, and a confirmation message appears beneath the index picture.

2 Select [Execute], and press the MENU knob.

The copy starts.

During the copy, an execution message and progress bar are displayed.

When the copy finishes, the display returns to the thumbnail screen.

To cancel a copy operation

Press the RESET/RETURN button.

The copy is cancelled, and the display returns to the thumbnail screen.

To batch copy groups of clips/files

You can batch copy groups of clips from one SxS memory card to another SxS memory card.

When both HD-mode and SD-mode clips exist on the source SxS memory card, only clips in the currently selected mode are copied. This is a convenient way to extract clips in one of the modes.

You can also copy of the files in the General directory, either together with or separately from clips.

1 In the thumbnail screen, select the thumbnails of the clips to copy and then select THUMBNAIL >Copy All >All Clips.

The confirmation message “Copy All Clip?” appears.

2 Select [Execute], and press the MENU knob.

The copy starts.

During the copy, the progress of the copy is displayed.

If you executed the copy in HD mode, only HD-mode clips are copied.

If you executed the copy in SD mode, only SD-mode clips are copied.

To cancel the copy operation

Press the RESET/RETURN button.

When the copy finishes

A completion message appears, and the THUMBNAIL menu screen appears again.

To copy all files in the General directory

To copy all files only, without copying clips, select THUMBNAIL >Copy All >General Files in step 1.

To copy all files together with all clips, select THUMBNAIL >Copy All >All Clips & General Files in step 1.

Deleting Clips

You can delete clips from SxS memory cards.

Note

HD clips with OK marks cannot be deleted.

If you want to delete such clips, first delete the OK marks (see page 101).

1 In the thumbnail screen, select the thumbnail of the clip to delete, and then select THUMBNAIL >Delete Clip.

The screen changes to the properties screen of that clip, and a confirmation message appears beneath the index picture.

2 Select [Execute], and press the MENU knob.

The clip is deleted.

In the thumbnail screen, the clips that followed the deleted clip move up one position.

To batch delete groups of clips

You can batch delete groups of clips from an SxS memory card.

Notes

- When both HD-mode and SD-mode clips exist on the SxS memory card, only clips in the currently selected mode are deleted.

- In HD mode, clips with OK marks are not deleted, even when a deletion is executed for a group of clips that includes them.

1 In the thumbnail screen, select the thumbnails of the clips to delete and then select THUMBNAIL >Delete All Clips.

The confirmation message “Delete All Clips?” appears.

2 Select [Execute], and press the MENU knob.

The deletion starts.

During the deletion, the progress of the deletion is displayed.

If you executed the deletion in HD mode, only HD-mode clips are deleted.

If you executed the deletion in SD mode, only SD-mode clips are deleted.

To cancel the deletion

Press the RESET/RETURN button.

When the deletion finishes

A completion message appears, and the THUMBNAIL menu screen appears again.

Displaying the Expand Thumbnail Screen

The expand thumbnail screen allows you to search inside clips by using thumbnails (*see page 95*), to change index pictures (*see page 106*), and to add and delete shot marks (*see page 106*).

To display the screen

In the thumbnail screen, select a thumbnail and press the DISP SEL/EXPAND button (*see page 21*) or select THUMBNAIL >Thumbnail View >Forward Expansion.

An expand thumbnail screen for the selected clip appears.

Expand thumbnail screen in UDF/FAT-HD mode

UDF / **FAT-HD**

In UDF mode or FAT-HD mode, the selected clip is divided into 12 equally-sized blocks, and a

thumbnail of the first frame in each block is displayed.

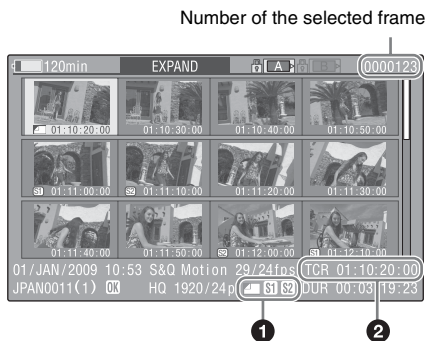

Clip properties are shown at the bottom of the screen.

Except for the items listed below, the information displayed here is the same as the information displayed in the normal thumbnail screen.

1 Frame information

This displays frame information using icons.

	Index picture
	Frame with Shot Mark 1
	Frame with Shot Mark 2

The same icons are also displayed beneath the thumbnails. However, when several icons could be displayed for the same frame, one icon is selected for display, in the order of priority Index picture > Shot Mark 1 > Shot Mark 2.

2 Timecode

This displays the timecode of the selected frame in the expand thumbnail screen.

Expand thumbnail screen in FAT-SD mode

FAT-SD

In FAT-SD mode, only in the case of clips that have been split into partial files because the file size was larger than 2 GB, a thumbnail of the first frame of each partial file is displayed.

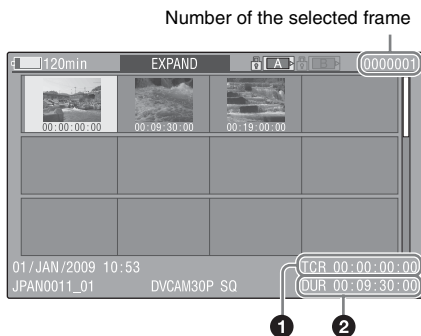

Clip properties are displayed at the bottom of the screen.

Except for the items listed below, the information displayed here is the same as the information displayed in the normal thumbnail screen.

1 Timecode

This is the timecode of the selected partial file.

2 Duration

This is the duration of the selected partial file.

To increase the number of divisions

When you press the DISP SEL/EXPAND button, or select THUMBNAIL >Thumbnail View >Forward Expansion, the divided clip or file is further divided into 12 equally-sized blocks (a clip or file that has been divided into 12 is further divided into 12, for $12 \times 12 = 144$ divisions). You can repeat the same operation to increase the number of division.

To return to the previous division level

Press the DISP SEL/EXPAND button with the SHIFT button held down, or select THUMBNAIL >Thumbnail View >Back Expansion. The expand thumbnail screen returns to the previous division level.

Displaying the Essence Mark Thumbnail Screen

UDF / FAT-HD

In the essence mark thumbnail screen (shown only in HD mode), you can search for shot marks in clips (see page 95), change index pictures (see page 106), and add and delete shot marks (see page 106).

- 1 In the thumbnail screen, select the thumbnail of a clip, and press the ESSENCE MARK button (see page 23) or select THUMBNAIL >Thumbnail View >Essence Mark Thumbnail.

The essence mark thumbnail screen appears, and a selection list is displayed.

- 2 Select the type of the essence mark thumbnail screen

All: Display all frames marked with essence marks.

Rec Start: Display frames marked with Rec Start marks and of the first frames of clips when the first frames are not marked with Rec Start marks (In UDF mode only).

Shot Mark1: Display only frames marked with Shot Mark1 marks.

Shot Mark2: Display only frames marked with Shot Mark2 marks.

You can also select Shot Mark 0 and Shot Mark 3 to Shot Mark 9.

If you have recorded clips by using planning metadata that defined names for Shot Mark 0 to Shot Mark 9, the defined names are displayed instead of the above item names in the list.

Example shot mark thumbnail screen (with Shot Mark1 selected)



The properties of the clip appear at the bottom of the screen.

Except for the following item, the information displayed here is the same as the information displayed in the expand thumbnail screen.

1 Timecode

This is the timecode of the selected frame in the shot mark thumbnail screen.

Adding and Deleting Shot Marks

UDF / FAT-HD

In the essence mark thumbnail screen (*see page 105*) or the expand thumbnail screen (*see page 104*), you can add thumbnails to any frame of clips recorded in HD mode, and delete recorded shot marks.

To add shot marks

- 1 Select the frame where you want to add a shot mark, and then select THUMBNAIL > Set Shot Mark > Add Shot Mark1 (or Add Shot Mark2).**

The properties screen of the selected frame appears, and a confirmation message appears below the image.

- 2 Select [Execute], and press the MENU knob.**

To delete shot marks

- 1 Select the frame where you want to delete a shot mark, and then select THUMBNAIL > Set Shot Mark > Delete Shot Mark1 (or Delete Shot Mark2).**

The properties screen of the selected frame appears, and a confirmation message appears below the image.

- 2 Select [Execute], and press the MENU knob.**

Changing Clip Index Pictures

UDF / FAT-HD

In the essence mark thumbnail screen (*see page 105*) or the expand thumbnail screen (*see page 104*), you can set the selected frame of the clip recorded in UDF/FAT-HD mode as the index picture.

- 1 Select the thumbnail of the frame that you want to use as the index picture, and then select THUMBNAIL > Set Index Picture.**

The properties screen of the selected frame appears, and a confirmation message appears below the image.

- 2 Select [Execute], and press the MENU knob.**

Note

Even if you set the index picture to a frame that is not the first frame of a clip, playback of that clip from a thumbnail screen always begins at the first frame.

Dividing Clips

FAT-HD

In the expand thumbnail screen (*see page 104*) and the essence mark thumbnail screen (*see page 105*), clips recorded in FAT-HD mode can be divided into two clips at the selected frame.

- 1 Select the thumbnail of the frame where you want to divide the clip, and then select THUMBNAIL > Divide Clip.**

The properties screen of the selected frame appears, and a confirmation message appears below the image.

- 2 Select [Execute], and press the MENU knob.**

The clip is divided at the selected frame, and two clips with different names are created.

The first four characters of the clip name are taken from the name of the original clips, and the last four characters are new serial numbers.

Example: When the name of a newly recorded clip would be EFGH0100, and a clip named ABCD0002 is divided, the names of the two newly created clips are ABCD0100 and ABCD0101.

Note

When there is not enough remaining capacity on the SxS memory cards to store the divided clips, a message appears to inform you that there is not enough capacity.

Setup Menu Organization and Levels

On this camcorder, settings for shooting and playback are made in the setup menu, which appears in the viewfinder.

The setup menu can also be displayed on an external video monitor (*see page 167*).

Setup Menu Organization

The setup menu consists of the following menus.

Us: USER menu

Menu items added in any order from other menus (*see page 111*)

Op: OPERATION menu

Settings related to shooting, except settings related to picture quality (*see page 112*)

Pa: PAINT menu

Settings related to picture quality (*see page 129*)

Th: THUMBNAIL menu

Settings related to clip thumbnails (*see page 96*)

Note

The THUMBNAIL menu is used only when a thumbnail screen (*see page 91*) is displayed. It is disabled when no thumbnail screen is displayed.

Ma: MAINTENANCE menu

Settings related to audio and timecode (*see page 135*)

Fi: FILE menu

Settings related to file operations (*see page 150*)

Setup Menu Levels

See “THUMBNAIL Menu Configuration” (page 96) for the organization of the THUMBNAIL menu.

USER menu (*see page 111*)

USER

- Format Media
- Rec Function
- Input/Output
- Clip
- Assignable SW
- Camera Config

OPERATION Menu (*see page 112*)

OPERATION

- Format
- Format Media
- Input/Output
- Super Impose
- LCD
- Rec Function
- Assignable SW
- VF Setting
- Marker
- Gain Switch
- TLCS
- Zebra
- Display On/Off
- “!” LED
- Auto Iris
- Shot ID
- Shot Display
- White Setting
- Offset White
- Shutter
- Time Zone
- Clip
- Plan.Metadata
- USB

PAINT Menu (see page 129)

PAINT

- Switch Status
- White
- Black
- Flare
- Gamma
- Black Gamma
- Knee
- White Clip
- Detail(HD Mode)
- Detail(SD Mode)
- Aperture
- Skin Detail
- Matrix
- Multi Matrix
- V Modulation
- Low Key Saturation
- Noise Suppress

FILE Menu (see page 150)

FILE

- User
- All
- Scene
- Reference
- Lens

MAINTENANCE Menu (see page 135)

MAINTENANCE

- White Shading
- Black Shading
- Battery
- Audio
- WRR Setting
- Timecode
- Essence Mark
- Camera Config
- Preset White
- White Filter
- DCC Adjust
- Auto Iris2
- Genlock
- ND Comp
- Lens
- Auto Shading
- APR
- Trigger Mode
- Network Setting
- Wi-Fi Setting
- Clock set
- Language
- Hours Meter
- Version

Basic Setup Menu Operations

To display the setup menu

Set the MENU ON/OFF switch to ON, or press the MENU button.

The camcorder enters menu mode and the menu list appears on the screen.

A cursor appears over the first two characters of the most recently used menu, and the corresponding menu item selection area appears to the right.

Example: When the cursor is positioned at the OPERATION menu

Menu list

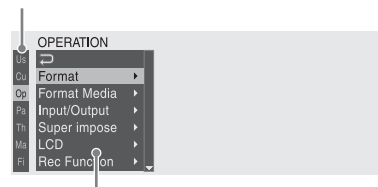

Menu item selection area

Note

The setup menu cannot be used when the camcorder is in focus magnification mode. Exit focus magnification mode by pressing the assignable switch to which the Focus Mag function has been assigned.

To make menu settings

1 Turn the MENU knob, or press the \uparrow or \downarrow button, to move the cursor to the item that you want to set.

A list of selectable menu items appears in the menu item selection area to the right of the icon.

2 Press the MENU knob or the SET button.

The cursor moves to the menu item selection area.

You can also move the cursor to the menu item selection area by pressing the \Rightarrow button.

- The menu item selection area displays a maximum of seven lines. You can scroll through menus with more than seven lines by moving the cursor up and down. Triangles appear at the upper right and lower right of the menu item selection area to indicate that a menu is scrollable.



Appears when more menu items are available below the last line. (\blacktriangle appears when more menu items are available above the first line.)

Menu item selection area

- \blacktriangleright appears to the right when more detailed sub-items are available.
- Settings appear to the right when a menu item has no sub-items.
- You can select \leftarrow to return to the previous level.

3 Turn the MENU knob, or press the \uparrow or \downarrow button, to move the cursor to the item that you want to set, and then confirm by pressing the MENU knob or the SET button.

The sub-items area appears to the right of the menu item selection area, and the cursor moves to the first sub-item.

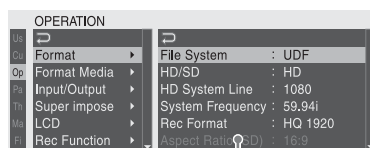

Sub-items area

- Displays sub-items and their current settings
- To return to the previous level, select \leftarrow press the \leftarrow button, or push the MENU CANCEL/PRST/ESCAPE switch down to the ESCAPE side.

- 4 Turn the MENU knob, or press the \uparrow or \downarrow button, to move the cursor to the sub-item that you want to set, and then confirm the selection by pressing the MENU knob or the SET button.**

The settings of the selected sub-item appear, and the cursor moves to the currently selected value.

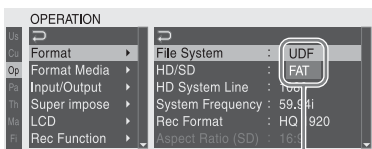

Settings area

- The settings area displays a maximum of seven lines. You can scroll through menus with more than seven sub-items by moving the cursor up and down. Triangles appear at the upper right and lower right of the settings area to indicate that a sub-item menu is scrollable.
- For sub-items with a large settings range (for example, -99 to +99), the settings area is not displayed. Instead, the sub-item name is highlighted to indicate that the sub-item can be set.

- 5 Turn the MENU knob, or press the \uparrow or \downarrow button, to select the value to set, and then confirm by pressing the MENU knob or the SET button.**

The setting is changed, and the display is updated to show the new setting.

If you select [Execute] for an executable item, the corresponding function is executed.

Items that require confirmation before execution

In step 3, the menu disappears and a confirmation message appears if you select an item that requires confirmation before execution. Follow the instructions in the message to execute or cancel the operation.

To enter text

Some items, such as time data or file names, must be set by entering text. When you select one of these items, the text entry area is highlighted, with “SET” displayed to the right.

- 1 Turn the MENU knob, or press the \uparrow or \downarrow button, to select a character, and then confirm by pressing the MENU knob or the SET button.**

The cursor moves to the next position.

To return to the previous position, push the MENU CANCEL/PRST/ESCAPE switch down to the ESCAPE side.

- 2 Select characters for all positions up to the last.**

The cursor moves to “SET”.

- 3 Press the MENU knob or the SET button.**

This confirms the setting.

To cancel the setting change

Push the MENU CANCEL/PRST/ESCAPE switch down to the ESCAPE side.

To reset a setting to the initial value

- 1 Before a setting is changed or after a setting change is cancelled, push the MENU CANCEL/PRST/ESCAPE switch up to the CANCEL/PRST side.**

- 2 When the message to confirm whether the current setting is reset to the initial value, push the MENU CANCEL/PRST/ESCAPE switch up to the CANCEL/PRST side again.**

The current setting is reset to the initial value.

To exit the menu

Set the MENU ON/OFF switch to OFF or press the MENU button.

The normal camera picture reappears.

Menu List

USER Menu (Factory Default Configuration)

The USER menu consists of the following items when it is in the factory default state.

- Format Media (*see page 113*)
- Input/Output (*see page 114*)
- Rec Function (*see page 116*)
- Assignable Sw¹⁾ (*see page 117*)
- Clip (*see page 125*)
- Camera Config²⁾ (*see page 142*)

1) Excluding sub-item <0>

2) Contains only User Menu Only as sub-item

You can change the configuration of the USER menu by adding desired menu items and arranging them in a desired order.

For details, refer to the Supplement supplied in the CD-ROM (labeled “Manuals for Solid-State Memory Camcorder”).

OPERATION Menu

Settings in bold are the factory default values.

OPERATION				
Menu items	Sub-item	Settings	Description	
Format Specifies the camcorder's recording mode, operating mode and recording format.	File System	UDF/FAT	Switches between UDF and FAT as the recording mode (execute by selecting Execute).	
	HD/SD	HD/SD	Switches between HD or SD as the operating mode (execute by selecting Execute).	
	Note			
	When the optional CBK-MD01 is not installed, [SD] cannot be selected. (SD recording is not allowed.)			
	HD System Line	1080/720	When the operating mode is HD, sets the number of system lines to 1080 or 720 (execute by selecting Execute).	
	System Frequency	The available settings vary depending on the settings in HD/SD, HD System Line, and Country.	59.94i/29.97P/23.98P	When the HD/SD setting is [HD], the HD System Line setting is [1080], and the Country setting is other than [PAL Area].
			50i/25P	<ul style="list-style-type: none"> When the HD/SD setting is [HD], the HD System Line setting is [1080], and the Country setting is [PAL Area]. When the HD/SD setting is [SD], and the Country setting is [PAL Area].
59.94P/29.97P/23.98P			When the HD/SD setting is [HD], the HD System Line setting is [720], and the Country setting is other than [PAL Area].	
50P/25P			When the HD/SD setting is [HD], the HD System Line setting is [720], and the Country setting is [PAL Area].	
59.94i/29.97P			When the HD/SD setting is [SD], and the Country setting is other than [PAL Area].	

OPERATION				
Menu items	Sub-item	Settings	Description	
Format Specifies the camcorder's operating mode and recording format.	Rec Format	The available settings vary depending on the settings in UDF/FAT, HD/SD, HD System Line, and System Frequency.	Selects the recording format (execute by selecting Execute).	
		HD422 50/HD420 HQ	<ul style="list-style-type: none"> When the UDF/FAT setting is [UDF], the HD/SD setting is [HD], the HD System Line setting is [1080]. When the UDF/FAT setting is [UDF], the HD/SD setting is [HD], the HD System Line setting is [720], and the System Frequency setting is [23.98P].(When the System Frequency setting is [25P], [29.97P], or [50P], this setting is fixed to [HD422 50].) 	
		HQ 1920/HQ 1440	When the UDF/FAT setting is FAT, the HD/SD setting is [HD], the HD System Line setting is [1080], and the System Frequency setting is [29.97P] or [25P].	
		HQ 1920/HQ 1440/SP 1440	When the UDF/FAT setting is FAT, the HD/SD setting is [HD], the HD System Line setting is [1080], and the System Frequency setting is other than [29.97P] and [25P].	
		HQ 1280	When the UDF/FAT setting is FAT, the HD/SD setting is [HD], and the HD System Line setting is [720].	
		IMX50/DVCAM	When the UDF/FAT setting is [UDF] and the HD/SD setting is [SD].	
		DVCAM	When the UDF/FAT setting is [FAT] and the HD/SD setting is [HD].	
		Aspect Ratio (SD)	16:9/4:3	Selects the aspect ratio when SD mode is selected (execute by selecting Execute).
		Audio Length(IMX)	24bit/16bit	Selects the audio bit rate for recording in IMX format.
		Country	NTSC Area/NTSC(J) Area/PAL Area	Selects the area of use (execute by selecting Execute).
Format Media Executes a media format.	Media(A)	Execute/Cancel	Initializes the SxS memory card in slot A (execute by selecting Execute).	
	Media(B)	Execute/Cancel	Initializes the SxS memory card in slot B (execute by selecting Execute).	

OPERATION			
Menu items	Sub-item	Settings	Description
Input/Output Makes settings related to I/O signals.	In FAT mode	HD&HDV /SD&HDV/ SD&DV	Selects the signals output from the video connectors and the i.LINK (HDV/DV) connector. When the HD/SD setting is SD, "SD&DV" or "SD" is selected.
	Output& i.LINK		
	In UDF mode	HD /SD	
	Output		
	23.98P Output	Psf /Pull Down	When the video format is HQ 1920/23.98P or HQ 1440/23.98P, selects whether to use progressive output (Psf) or pulldown output (Pull Down).
	Source Select ^{a)}	Camera /i.LINK /External	Selects whether to use the camera picture (Camera), the i.LINK input (in FAT mode only) or the SDI/composite input (External) as the video input source.
Notes			
<ul style="list-style-type: none"> • When Rec Source is assigned to the ASSIGN. 2 switch, this setting is disabled. • Changing the setting of File System >UDF/FAT resets this item to [Camera] (factory default setting). 			
	Ext Video Source ^{a)}	HD SDI /SD SDI/ Composite	Selects the external input signal. HD-SDI: HDSDI signals (in HD mode only) SD-SDI: SDDSDI signals Composite: Composite signals
	i.LINK I/O	Enable/ Disable	Selects whether to enable or disable input and output of signals via the i.LINK (HDV/DV) connector. When Enable is selected, you can execute auto black balance adjustment during i.LINK output.
	SDI Output	On /Off	Turns on or off the output of signals from the HD/SD SDI OUT connector.
	SDI Out Super	On/ Off	Turns on or off the superimposition of text information on the output of the HD/SD SDI OUT connector
	Video Out Super	On/ Off	Turns on or off the superimposition of text information on the output of the VIDEO OUT connector.
	Live & Play	On/ Off	Turns Live & Play function on or off.

OPERATION			
Menu items	Sub-item	Settings	Description
Input/Output Makes settings related to I/O signals.	Down Converter	Crop/Letter/Squeeze	Selects the signal conversion mode for output of SD signals. Crop: Crop the edges of the 16:9 picture and output as a 4:3 picture. Letter: Mask the top and bottom of the 4:3 picture and display in the center of the screen as a 16:9 picture. Squeeze: Squeeze the 16:9 picture horizontally and output as a 4:3 picture.
	Wide ID	Through/Auto	Selects whether to add a wide ID signal to the SD output signal. Through: Output without adding a wide ID signal. Auto: Add and output a wide ID signal when the Down Converter setting is Squeeze.
	Wide Mode(EXT) ^{a)}	Auto/16:9	When the input signal is SD, select the method that determines whether the signal is treated as a wide signal. Auto: When wide a ID signal is detected in the input signal, treat the signal as a wide signal and set the up-converter operating mode to squeeze mode. When a wide ID signal is not detected, set the upconverter operating mode to edge crop mode and do not record a wide ID signal. 16:9: Always treat the signal as a wide signal and set the upconverter operating mode to squeeze mode.
	Setup Remove(EXT) ^{a)}	7.5%/0.0%	When the Country setting is other than [PAL Area], selects whether to remove the setup level of analog input video signals. 7.5%: Remove the setup. 0.0%: Do not remove the setup.
Super Impose Makes settings related to superimposed text and markers.	Super(VF Display)	On/Off	When the setting of Input/Output >SDI Out Super or Video Out Super is On, superimpose text information on the output from the HD/SD SDI OUT connector, and VIDEO OUT connector, as specified (On or Off) for each item.
	Super(Menu)	On/Off	
	Super(Timecode)	On/Off	
	Super(Marker)	On/Off	When the setting of Input/Output >Video Out Super is On, specifies whether to superimpose markers on the output from the VIDEO OUT connector.
LCD	LCD Color	-99 to ± 0 to +99	Adjusts the LCD color.
	LCD Marker&Zebra	On/Off	Turns the marker and zebra display in the LCD monitor on or off.

OPERATION			
Menu items	Sub-item	Settings	Description
Rec Function Makes settings related to special recording modes.	Slow & Quick	On/Off	Turns the Slow & Quick Motion function on or off. (When this is set to On, the Picture Cache Rec, Interval Rec, and Frame Rec sub-items are set to Off.)
	Note When Picture Cache is assigned to an assignable switch, this item is disabled (displayed in grey).	Frame Rate	The available settings vary depending on the Format >HD System Line setting.
When Format >Country is set to other than [PAL Area] in UDF mode or in FAT mode: 1 to 30			When the HD System Line setting is 1080.
When Format >Country is set to [PAL Area] in UDF mode: 1 to 25			
		When Format >Country is set to other than [PAL Area] in UDF mode or in FAT mode: 1 to 30 to 60	When the HD System Line setting is 720.
		When Format >Country is set to [PAL Area] in UDF mode: 1 to 25 to 50	
	Clip Continuous Rec	On/Off	Turns the Clip Continuous Rec function on or off. (When this is set to On, the Slow & Quick, Picture Cache Rec, Interval Rec, and Frame Rec sub-items are set to Off.)
	Picture Cache Rec	On/Off	Turns the picture cache function on or off. (When this is set to On, the Slow & Quick, Interval Rec, Frame Rec sub-items are set to Off.)
	P. Cache Rec Time	0-2sec/2-4sec/4-6sec/6-8sec/8-10sec/10-12sec/12-14sec/13-15sec	When the Picture Cache Rec setting is On, set the picture cache time.
	Interval Rec	On/Off	Turns the Interval Rec function on or off. (When this is set to On, the Slow & Quick, Picture Cache Rec, and Frame Rec sub-items are set to Off.)
	Frame Rec	On/Off	Turns the Frame Rec function on or off. (When this is set to On, the Slow & Quick, Picture Cache Rec, and Interval Rec sub-items are set to Off.)
	Number of Frames	The available settings vary depending on the settings in Format >HD System Line and Format >System Frequency.	When Interval Rec or Frame Rec is set to On, specifies the number of frames to shoot in one Interval Rec or Frame Rec take.
		2frame/6frame/12frame	When the HD System Line setting is 720, and the System Frequency setting is 59.94P or 50P.
		1frame/3frame/6frame/9frame	When the HD System Line setting is other than 720, or the System Frequency setting is other than 59.94P or 50P.

OPERATION			
Menu items	Sub-item	Settings	Description
Rec Function Makes settings related to special recording modes.	Interval Time	1/2/3/4/5/6/7/8/9/10/15/ 20/30/40/50 (sec) 1/2/3/4/5/6/7/8/9/10/15/ 20/30/40/50 (min) 1/2/3/ 4/6/12/24 (hour)	When the Interval Rec setting is On, sets the interval for Interval Rec shooting.
	Pre-Lighting	Off /2sec/5sec/10sec	If you want the video light to be turned on before Interval Rec shooting, select a number of seconds before the start of shooting. If you do not want it to be turned on, select Off.
	Live Logging ^{d)}	Live /View	In UDF mode: Selects the Live Logging operation mode. In FAT mode: Fixed to [Live] (live mode).
Note			
When one of Frame Rec, Interval Rec, and Clip Continuous Rec modes is selected, [View] cannot be selected. <i>For details on Live Logging functions, refer to the Supplement supplied in the CD-ROM (labeled "Manuals for Solid-State Memory Camcorder").</i>			
Assignable SW Assigns functions to assignable switches. <i>See "Assigning Functions to Assignable Switches" (page 155) for more information about assigning functions.</i>	<0>	<i>See page 155.</i>	Assigns function to ASSIGN. 0 switch.
	<1>		Assigns function to ASSIGN. 1 switch.
	<2>		Assigns function to ASSIGN. 2 switch.
	<3>		Assigns function to ASSIGN. 3 switch.
	<4>		Assigns function to ASSIGNABLE 4 switch.
	<5>		Assigns function to ASSIGNABLE 5 switch.
	RET		Assigns function to RET button on the lens.
C. Temp		Assigns function to COLOR TEMP. button.	
Zoom Speed	0 to 20 to 99		When Zoom has been assigned to the ASSIGNABLE 4 or 5 switch, specifies the zoom speed.

OPERATION				
Menu items	Sub-item	Settings	Description	
VF Setting Makes settings related to the viewfinder screen.	Color ^{b)}	-99 to ±0 to +99	Adjusts the density of the colors displayed in the viewfinder screen.	
	Mode ^{b)}	Color/B&W	Selects the display mode of the viewfinder. Color: Color B&W: Monochrome	
	Peaking Type ^{b)}	Normal/Color/Both	Selects the peaking type. Normal: Normal peaking Color: Color peaking Both: Both	
	Peaking Frequency ^{b)}	Normal/High	Selects Normal or High as the peaking frequency.	
	Peaking Color ^{b)}	White/Red/Yellow/Blue	When the Peaking Type setting is Color, selects the peaking color from among White, Red, Yellow, and Blue.	
	VF Detail Level ^{c)}	-99 to ±0 to +99	Adjusts the detail level (set on the camcorder) of the viewfinder	
	Color Peaking Level ^{b)}	Low/ Mid /High	When the Peaking Type setting is Both, selects the color peaking level from among Low, Mid, and High.	
	Marker Makes settings related to marker display in the viewfinder screen.	Setting	On/Off	Turns all markers on or off. Note When Marker is assigned to the ASSIGN. 2 switch, this setting is disabled.
		Center Marker	1/2/3/4/ Off	When the center marker is displayed, selects the type. Select Off if you do not want to display the marker. Note When three of Safety Zone, User Box, Guide Frame, and 100% Marker are set to [On], this setting cannot be turned on.
		Center H Position	-40 to 0 to 40	Specifies the horizontal position of the center marker.
Center V Position		-40 to 0 to 40	Specifies the vertical position of the center marker.	
Safety Zone		On/Off	Turns the safety zone display on or off. Note When three of Center Marker, User Box, Guide Frame, and 100% Marker are set to [On], this setting cannot be turned on.	
Safety Area		80%/90%/92.5%/95%	Selects the safety zone range.	
Aspect Marker		Line/Mask/ Off	When an aspect marker is to be displayed, selects the display method. Select Off if you do not want to display the marker. Line: Show as white lines. Mask: Display by lowering the video signal level of areas outside the marker range.	
Aspect Select		15:9/14:9/13:9/4:3/ 1.66:1/1.85:1/2.35:1/2.4:1	Selects the aspect ratio of the marker.	

OPERATION				
Menu items	Sub-item	Settings	Description	
Marker Makes settings related to marker display in the viewfinder screen.	100% Marker	On/Off	Turns the 100% safety zone display on or off. Note When three of Center Marker, Safety Zone, User Box, and Guide Frame are set to [On], this setting cannot be turned on.	
	Aspect Mask	0% to 30% to 90% (10% step)	When the Aspect Marker setting is Mask, specifies the video signal level of areas outside the marker range as a percentage value relative to the video signal level of areas inside the marker range.	
	User Box	On/Off	Turns the box cursor display on or off. Note When three of Center Marker, Safety Zone, Guide Frame, and 100% Marker are set to [On], this setting cannot be turned on.	
	User Box Width	40 to 500 to 999	Specifies the box cursor width (distance from the center to the left and right edges).	
	User Box Height	70 to 500 to 999	Specifies the box cursor height (distance from the center to the top and bottom edges).	
	User Box H Position	-479 to 0 to 479	Specifies the horizontal position of the box cursor center.	
	User Box V Position	-464 to 0 to 464	Specifies the vertical position of the box cursor center.	
	Guide Frame	On/Off	Turns display of the guide frame on or off. Note When three of Center Marker, Safety Zone, User Box, and 100% Marker are set to [On], this setting cannot be turned on.	
	Gain Switch Makes settings related to the GAIN switch.	Gain Low	-6dB/-3dB/ 0dB /3dB/ 6dB/9dB/12dB/18dB/ 24dB/30dB/36dB/42dB	Specifies the gain value for the L position of the GAIN switch.
		Gain Mid	-6dB/-3dB/0dB/3dB/ 6dB /9dB/12dB/18dB/ 24dB/30dB/36dB/42dB	Specifies the gain value for the M position of the GAIN switch.
Gain High		-6dB/-3dB/0dB/3dB/ 6dB/9dB/ 12dB /18dB/ 24dB/30dB/36dB/42dB	Specifies the gain value for the H position of the GAIN switch.	
Gain Turbo		-6dB/-3dB/0dB/3dB/ 6dB/9dB/12dB/18dB/ 24dB/30dB/36dB/ 42dB	Specifies the gain value for the Turbo Gain function, which can be assigned to an assignable switch.	
Shockless Gain		On/Off	Turns shockless gain (a function that switches smoothly when the gain is switched) on or off.	

OPERATION				
Menu items	Sub-item	Settings	Description	
TLCS Makes settings related to total level control.	Mode	Backlight/Standard/ Spotlight	Selects the auto iris mode used when the TLCS system is activated. Backlight: Backlight mode (lessens the blackout of the main subject that occurs under backlit conditions) Standard: Standard mode Spotlight: Spotlight mode (lessens the whiteout of the main subject that occurs under a spotlight)	
	Speed	-99 to ± 0 to +99	Specifies the control speed (speed of reaction to changes in the video) used when the TLCS system is activated. (Larger values specify quicker reaction times.)	
	AGC	On/Off	Turns the AGC (auto gain control) function on or off.	
	AGC Limit	3dB/6dB/9dB/ 12dB / 18dB	Specifies the maximum gain used when AGC is on.	
	AGC Point	F5.6/F4/ F2.8	Specifies the F value where control by auto iris switches to control by AGC, used when AGC is on.	
	Auto Shutter	On/Off	Turns the auto shutter function on or off.	
	Auto Shutter Limit	1/100 / 1/150 / 1/200 / 1/250	Selects the maximum shutter speed used when auto shutter is on.	
	Auto Shutter Point	F5.6/F8/F11/ F16	Specifies the F value where control by auto iris switches to control by auto shutter, used when auto shutter is on.	
	Zebra Makes settings related to zebra displays.	Zebra Select	1/2/BOTH	Selects the zebra pattern type (Zebra1, Zebra2, Both).
		Zebra1 Level	50% to 70% to 107%	Specifies the Zebra1 display level.
Zebra1 Aperture Level		1 to 10% to 20%	Specifies the Zebra1 aperture level.	
Zebra2 Level		52% to 100% to 109%	Specifies the Zebra2 display level.	
Display On/Off Selects the items to display in the viewfinder screen.	Video Level Warnings	On/Off	Turns the warnings that appear when the video level is too bright or too dark on or off.	
	Brightness Display	On/Off	Turns the numerical indication of the video brightness on or off.	
	Histogram Display (In HD mode only)	On/Off	Turns the histogram display of video signal levels on or off.	
	Lens Info	Meter/Feet/Off	Selects whether or not to display the depth of field indication and the unit for display of the depth of field. Meter: Displayed in meters Feet: Displayed in feet Off: Do not display	
	Focus Position	On/Off	Turns the indication of the lens focus position on or off.	
	Zoom Position	On/Off	Turns the indication of the lens zoom position on or off.	
	Audio Level Meter	On/Off	Turns the display of the audio level meters on or off.	

OPERATION			
Menu items	Sub-item	Settings	Description
Display On/Off Selects the items to display in the viewfinder screen.	Timecode	On/Off	Turns the display of time data (timecode, user bits, counter, duration) on or off.
	Battery Remain	On/Off	Turns the indications of the remaining battery time and input voltage on or off.
	Media Remain	On/Off	Turns the indication of the remaining media capacity on or off.
	TLCS Mode	On/Off	Turns the indication of the TLCS operating mode on or off.
	Focus Mode	On/Off	Turns the indication of the focus operating mode on or off.
	White Balance Mode	On/Off	Turns the indication of the white balance mode on or off.
	Filter Position	On/Off	Turns the indication of the ND filter setting on or off.
	Iris Position	On/Off	Turns the indication of the iris position on or off.
	Gain Setting	On/Off	Turns the indication of the gain setting on or off.
	Shutter Setting	On/Off	Turns the indications of the shutter mode and shutter speed on or off.
	Color Temp	On/Off	Turns the indication of the color temperature on or off.
	Video Format	On/Off	Turns the indication of the video format on or off.
	System Line	On/Off	Turns the indication of the system lines on or off.
	Rec Mode	On/Off	Turns the indication of special recording modes (S&Q, Interval, Frame Rec, Picture Cache Rec) on or off.
	Extender	On/Off	Turns the lens extender indication on or off.
WRR RF Level	On/Off	Turns the indication of the digital wireless receiver reception level on or off.	
Clip Number(PB)	On/Off	Turns the indication of clip information on or off.	

OPERATION			
Menu items	Sub-item	Settings	Description
“!” LED ^{c)}	Gain<!>	On/Off	Turns on or off the function to light the ! indicator when the gain is set to other than 0 dB.
	Shutter <!>	On/Off	Turns on or off the function to light the ! indicator when the SHUTTER selector is set to ON.
	White Preset <!>	On/Off	Turns on or off the function to light the ! indicator when the WHITE BAL switch is set to PRST.
	ATW Run <!>	On/Off	Turns on or off the function to light the ! indicator when White Setting >White Switch is set to [ATW].
	Extender <!>	On/Off	Turns on or off the function to light the ! indicator when the lens extender is used.
	Iris Override <!>	On/Off	Turns on or off the function to light the ! indicator when the reference value of auto iris adjustment is not the standard value.
Auto Iris Makes settings related to auto iris.	Iris Override	On/Off	Turns iris override (a setting that opens or closes the iris more than normal) on or off.
	Iris Speed	-99 to ±0 to +99	Specifies the iris control speed (speed of reaction to changes in the video). (Larger values specify quicker reaction times.)
	Clip High light	On/Off	Turns on or off the function that disregards highlights and forces a flatter reaction to high luminance.
	Iris Window	1/2/3/4/5/6/Var	Selects the auto iris detection window type. Var: Variable
	Iris Window Indication	On/Off	Turns the indication of the auto iris detection window frame on or off.
Shot ID Creates the shot IDs superimposed on the color bars.	ID-1		Creates ID-1 strings (up to 16 characters) superimposed.
	ID-2		Creates ID-2 strings (up to 16 characters) superimposed.
	ID-3		Creates ID-3 strings (up to 16 characters) superimposed.
	ID-4		Creates ID-4 strings (up to 16 characters) superimposed.
Shot Display Selects which shot data is superimposed on the color bars and recorded.	Shot Date	On/Off	Selects whether to superimpose the shot date (On) or not (Off).
	Shot Time	On/Off	Selects whether to superimpose the shot time (On) or not (Off).
	Shot Model Name	On/Off	Selects whether to superimpose the model name (On) or not (Off).
	Shot Serial Number	On/Off	Selects whether to superimpose the serial number (On) or not (Off).
	Shot ID Select	ID-1/ID-2/ID-3/ID-4/ Off	Selects whether or not to superimpose the shot ID set with the Shot ID item and which shot ID is superimposed.

OPERATION			
Menu items	Sub-item	Settings	Description
White Setting Makes settings related to auto white balance adjustments.	White Switch	Memory/ATW	Specifies the operating mode selected by the B position of the WHITE BAL switch. Memory: Auto white balance ATW: Auto tracing white balance
	Shockless White	Off/1/2/3	Specifies the reaction speed when the WHITE BAL switch setting is changed. Off is an instant reaction, and 1 is faster than 2 or 3.
	ATW Speed	1/2/3/4/5	Specifies the reaction speed when the White Switch setting is [ATW]. 1 is the fastest reaction.
	AWB Fixed Area	On/Off	Specifies whether auto white balance is executed at the center of the screen. On: Execute in an area corresponding to 25% of the height and width of the screen. Off: Execute in an area corresponding to 70% of the height and width of the screen.
	Filter White Memory	On/Off	Specifies whether to allocate a white balance memory area for each FILTER knob position. On: Allocation a white balance memory area for each FILTER knob position. Off: Use A/B memory regardless of the filter position.

OPERATION			
Menu items	Sub-item	Settings	Description
Offset White Makes settings related to white balance offset values.	Offset White <A>	On/Off	Specifies whether to add (On) or not to add (Off) an offset value to the white balance value in memory A.
	Warm Cool <A>	Approximate color temperature	When the setting of Offset White<A> is [On], specifies (as a color temperature) the offset to add to the white balance value in memory A. (Note that the error range becomes larger for higher offset color temperatures. Adjust while viewing the actual video.)
	Warm Cool Balance<A>	-99 to ± 0 to +99	Specifies a more precise color temperature, for use when satisfactory video cannot be obtained with the Warm Cool <A> setting.
	Offset White 	On/Off	When this is set to [On], the offset adjusted set with this item is added to the white balance of channel B.
	Warm Cool 	Approximate color temperature	When the setting of Offset White is [On], specifies (as a color temperature) the offset to add to the white balance value in memory B. (Note that the error range becomes larger for higher offset color temperatures. Adjust while viewing the actual video.)
	Warm Cool Balance	-99 to ± 0 to +99	Specifies a more precise color temperature, for use when satisfactory video cannot be obtained with the Warm Cool setting.
Shutter Makes settings related to the shutter setting.	Shutter Select	Second/Degree	Specifies the unit used to select shutter speeds. Second: Select in units of seconds. Degree: Select in units of degrees.
	Slow Shutter	On/Off	Turns the SLS mode on or off.
	SLS Frames	2Frames/3Frames/ 4Frames/Frames/ 6Frames/7Frames/ 8Frames/16Frames	Selects the number of accumulated frames in SLS mode.
Time Zone Specifies the time zone.	Zone	-12:00 to +0:00 to +14:00 (in steps of 30 minutes)	Specifies a difference from UTC (Greenwich Mean Time) in units of 30 minutes.

OPERATION			
Menu items	Sub-item	Settings	Description
Clip Make settings for clip name or clip management.	Auto Naming	In Fat mode: Title/ Plan In UDF mode: C****/ Title/ Plan	Selects the clip naming format. C**** : XDCAM standard name (In UDF mode only) Title : Name specified by Title Prefix Plan : Name specified in planning metadata (if no name is specified in planning metadata, the name specified by Title Prefix is selected.)
Note Do not assign clip names that begin with the “.” (period) symbol. Clips with names in which the first character is “.” cannot be viewed on the application software for computers.			

OPERATION			
Menu items	Sub-item	Settings	Description
Clip Make settings for clip name or clip management.	Title Prefix	Text input	Specifies the title part (4 to 46 alphanumeric characters) of clip titles. When the currently specified title is eight characters or fewer in length, the entire title appears. When the title is longer than eight characters, the first seven characters appear and a “...” symbol appears in place of the eighth character. Displays the Character Set screen.
Note Do not assign clip names that begin with the “.” (period) symbol. Clips with names in which the first character is “.” cannot be viewed on the application software for computers.			Character Set screen configuration <ul style="list-style-type: none"> Character selection area (three lines) Select the character to insert at the title prefix cursor position. !#\$%()+,-.;:=@[]^_~0123456789 abcdefghijklmnopqrstuvwxyz ABCDEFGHIJKLMNOPQRSTUVWXYZ Cursor operation area (one line) Space: Changes the character at the cursor position to a space INS: Inserts a space at the cursor position DEL: Deletes the character at the cursor position ←: Moves the cursor to the left →: Moves the cursor to the right ESC: Cancels the change and return to the normal menu END: Executes the change and return to the normal menu Title prefix area (one line) An area to enter the title To set titles <ol style="list-style-type: none"> Turn the MENU knob or press the arrow buttons to select a character, highlighting it, in the character selection area, and then press the MENU knob or the SET button to insert it at the cursor position in the title prefix area. (The cursor moves to the right.) Repeat step 1 to add more characters to the title (using Space, INS, and DEL as required). When you have finished entering the title, select END to close the Character Set screen.

OPERATION			
Menu items	Sub-item	Settings	Description
Clip Make settings for clip name or clip management. Note Do not assign clip names that begin with the “.” (period) symbol. Clips with names in which the first character is “.” cannot be viewed on the application software for computers.	Number Set	00001 to 99999	Specifies the initial value of the numeric part (five digits) of clip names (The numeric part of clip names is limited to four digits number if Auto Naming is set to other than [Plan] or if planning metadata is invalid though Auto Naming is set to [Plan].)
	Name Display	Off/ Viewfinder /LCD Status/Both	Selects whether or not to display the name of the next clips to be recorded (in E-E mode), and where to display the name. Off: Do not display Viewfinder: Display on the viewfinder screen LCD Status: Display on the LCD monitor (with the display mode set to STATUS) Both: Display on both the viewfinder screen and the LCD monitor Note If a clip with the same name as the next clip to be recorded already exists on the recording media, then immediately after recording begins the clip name is displayed with a different serial number (when the selection is other than Off).
	Update	Media<A>/Media	Updates the management files on the media in the selected slot (execute by selecting Execute).

OPERATION			
Menu items	Sub-item	Settings	Description
Plan.Metadata Makes settings for operating planning metadata.	Load/Slot(A)	Execute/Cancel	Executes load of planning metadata from the SxS memory card in slot A. Select [Execute] to show the list of the planning metadata files stored in the slot A SxS memory card and select a file to execute the load.
	Load/Slot(B)	Execute/Cancel	Executes load of planning metadata from the SxS memory card in slot B. Select [Execute] to show the list of the planning metadata files stored in the slot B SxS memory card and select a file to execute the load.
	Load/USB (in UDF mode only)	Execute/Cancel	Executes load of planning metadata from the USB flash drive connected to the external device connector. Select [Execute] to show the list of the planning metadata files stored in the USB flash drive and select a file to execute the load.
	Properties	Execute/Cancel	Displays the detailed information in the planning metadata loaded on the camcorder (execute by selecting [Execute]).
	Clear	Execute/Cancel	Clears the planning metadata loaded on the camcorder (execute by selecting [Execute]).
	Clip Name Disp	Title1(ASCII)/ Title2(UTF-8)	Selects the display mode of the clip name specified in planning metadata (<i>see page 89</i>).
USB Makes settings for operating a USB flash drive (in UDF mode only)	Memory Rec	Enable/ Disable	Select whether to enable or disable the record of proxy data to a USB flash drive.
	Copy Current Clip	Execute/Cancel	Executes the copy of the proxy data for the current clip to a USB flash drive (execute by selecting [Execute]).
	Copy All Clips	Execute/Cancel	Executes the copy of the proxy data for all clips stored in the selected SxS memory card to a USB flash drive (execute by selecting [Execute]).
	Del All Memory Clips	Execute/Cancel	Executes the clear of the proxy data for all clips copied to a USB flash drive (execute by selecting [Execute]).
	Format USB Memory	Execute/Cancel	Executes the FAT32 format of a USB flash drive (execute by selecting [Execute]).

- a) When the optional CBK-HD02 is installed
- b) When the CBK-VF01 is used.
- c) When an HDVF series viewfinder is used.
- d) When the optional CBK-UPG01 is installed.

PAINT Menu

Settings in bold are the factory default values.

PAINT			
Menu items	Sub-item	Settings	Description
Switch Status Turns various signal correction functions and a test signal on or off.	Gamma	On/Off	Turns gamma correction on or off.
	Black Gamma	On/Off	Turns black gamma correction on or off.
	Matrix	On/Off	Turns linear matrix correction and user matrix correction on or off.
	Knee	On/Off	Turns knee correction on or off.
	White Clip	On/Off	Turns white clip correction on or off.
	Detail	On/Off	Turns detail correction on or off.
	Aperture	On/Off	Turns aperture correction on or off.
	Flare	On/Off	Turns flare correction on or off.
	Test Saw	On/Off	Turns the test saw signal on or off.
White Sets the color temperature, and performs manual white balance adjustment.	Color Temp <A>	1500K to 3200K to 50000K	Displays the white balance color temperature saved in memory A.
	Color Temp BAL <A>	-99 to ±0 to +99	Specifies the white balance gain values saved in memory A (linked R gain and B gain).
	R Gain <A>	-99 to ±0 to +99	Specifies the white balance R gain value saved in memory A.
	B Gain <A>	-99 to ±0 to +99	Specifies the white balance B gain value saved in memory A.
	Color Temp 	1500K to 3200K to 50000K	Displays the white balance color temperature saved in memory B.
	Color Temp BAL 	-99 to ±0 to +99	Specifies the white balance gain values saved in memory B (linked R gain and B gain).
	R Gain 	-99 to ±0 to +99	Specifies the white balance R gain value saved in memory B.
	B Gain 	-99 to ±0 to +99	Specifies the white balance B gain value saved in memory B.
Black Specifies the black level (level of the unilluminated parts of the video). You can achieve a desired look by adjusting the black level for deeper or shallower blacks.	Master Black	-99 to ±0 to +99	Specifies the master black level.
	R Black	-99 to ±0 to +99	Specifies the R black level.
	B Black	-99 to ±0 to +99	Specifies the B black level.

PAINT			
Menu items	Sub-item	Settings	Description
Flare Makes settings related to flare. Flare is light generated from a bright image region that spreads broadly across the image, adding light to dark regions and reducing contrast. It is caused by reflection inside the lens system.	Flare	On/Off	Turns flare correction on or off.
	Master Flare	-99 to ±0 to +99	Sets the master flare correction level.
	R Flare	-99 to ±0 to +99	Sets the R flare correction level.
	G Flare	-99 to ±0 to +99	Sets the G flare correction level.
	B Flare	-99 to ±0 to +99	Sets the B flare correction level.
Gamma Makes settings related to gamma. Gamma correction allows you to significantly alter the impression made by the video by adjusting the contrast.	Gamma	On/Off	Turns gamma correction on or off.
	Step Gamma	0.35 to 0.45 to 0.90 (0.05 step)	Specifies a gamma correction value in steps of 0.05
	Master Gamma	-99 to ±0 to +99	Specifies the master gamma level.
	R Gamma	-99 to ±0 to +99	Specifies the R gamma level.
	G Gamma	-99 to ±0 to +99	Specifies the G gamma level.
	B Gamma	-99 to ±0 to +99	Specifies the B gamma level.
	Gamma Select	The available settings vary depending on the setting in Gamma Category (see "Description").	Select the gamma table to use in gamma correction. When Gamma Category is STD: 1 DVW: DVW camcorder equivalent 2 ×4.5: ×4.5 gain 3 ×3.5: ×3.5 gain 4 240M: SMPTE-240M equivalent 5 R709: ITU-R709 equivalent (default setting) 6 ×5.0: ×5.0 gain When Gamma Category is HG: 1 3250: Condense 325% video input to 100% video output 2 4600: Condense 460% video input to 100% video output 3 3259: Condense 325% video input to 109% video output 4 4609: Condense 460% video input to 109% video output (default setting)
	Gamma Category	STD/HG	Selects use of standard gamma (STD) or HyperGamma (HG).
Black Gamma Makes settings related to black gamma correction. Black gamma correction allows you to reproduce gradations and color nuances in black or near-black (dark) parts of the picture.	Black Gamma	On/Off	Turns black gamma correction on or off.
	Gamma Level	-99 to ±0 to +99	Specifies the master black gamma level.
	Range	Low/L Mid/H.Mid/ High	Selects the black gamma correction effective range. LOW: 0 to 3.6% L.MID: 0 to 7.2% H MID: 0 to 14.4% HIGH: 0 to 28.8%

PAINT			
Menu items	Sub-item	Settings	Description
Knee Makes settings related to knee correction. Knee correction is processing that prevents washout by compressing the bright parts of the video according to an upper limit for the dynamic range of the recorded and output picture. The signal level where knee processing begins is called the “knee point”, and the slope of knee compression is called the “knee slope”.	Knee	On/Off	Turns knee correction on or off.
	Knee Point	50.0% to 95.0% to 109.0%	Specifies the knee point.
	Knee Slope	-99 to ±0 to +99	Specifies the knee slope.
	Knee Saturation	On/Off	Turns the knee saturation function on or off.
	Knee Saturation Level	-99 to ±0 to +99	Specifies the knee saturation level.
White Clip Makes settings related to white clipping adjustments. White clipping is processing that limits the maximum level of video output signals. The maximum video signal output value is called the “white clip level”.	White Clip	On/Off	Turns white clipping adjustment on or off.
	Level	[NTSC Area] or [NTSC Area(J)] is selected for Country 90.0% to 108.0% to 109.0% [PAL Area] is selected for Country 90.0% to 105.0% to 109.0%	Specifies the white clip level.

PAINT			
Menu items	Sub-item	Settings	Description
Detail(HD Mode)/ Detail(SD Mode) Makes settings related to details adjustments in HD mode and SD mode. Detail adjustment is processing that improves the clarity of the video by adding detail signals to the edges of the subject.	Detail	On/Off	Turns detail adjustment on or off.
	Level	-99 to ± 0 to +99	Specifies the detail level.
	H/V Ratio	-99 to ± 0 to +99	Specifies the mix ratio between the H detail level and the V detail level.
	Crispening	-99 to ± 0 to +99	Specifies the crispening level.
	Level Depend	On/Off	Turns the level depend adjustment function on or off.
	Level Depend Level	-99 to ± 0 to +99	Specifies the level depend level.
	Frequency	-99 to ± 0 to +99	Specifies the central frequency for H detail signals. Larger values give finer details.
	Knee Aperture	On/Off	Turns the knee aperture function on or off.
	Knee Aperture Level	-99 to ± 0 to +99	Specifies the knee aperture level.
	Limit	-99 to ± 0 to +99	Specifies the detail limiter values for both the white-side and black-side direction.
	White Limit	-99 to ± 0 to +99	Specifies the white-side detail limiter value.
	Black Limit	-99 to ± 0 to +99	Specifies the black-side detail limiter value.
	V-BLK Limit	-99 to ± 0 to +99	Specifies the black-side V detail limiter value.
	V Detail Creation	NAM/G/R+G/Y	Selects the source signal used to generate the V detail signal. NAM: A V detail signal created from the R signal, or a V detail signal created from the G signal, or a V detail signal created from the B signal, whichever is the signal with the highest level G: G signal G+R: Composite signal comprising the G signal and R signal in a 1:1 ratio Y: Y signal
	Cross Color (in SD mode only)	-99 to ± 0 to +99	Sets the cross color reduction level for details.

Note

When Detail is set to [Off] or OPERATION >Format >Country is set to [Pal Area], this setting is disabled.

PAINT			
Menu items	Sub-item	Settings	Description
Aperture Makes settings related to aperture correction. Aperture correction is processing to improve resolution by adding high-frequency aperture signals to the video signal, which corrects degeneration due to high-frequency characteristics.	Aperture	On/Off	Turns aperture correction on or off.
	Level	-99 to ±0 to +99	Sets the aperture level.
Skin Detail Makes settings related to skin detail correction. Skin detail correction is processing that increases or decreases the detail level of a specified color range (skin tone range), for the purpose of obtaining attractive reproduction of skin tones.	Skin Detail	On/Off	Turns skin detail correction on or off.
	Area Detection	Color detection screen	Detects the color to be targeted by skin detail correction.
	Area Indication	On/Off	Turns on or off the function that displays a zebra pattern in the area targeted by skin detail correction.
	Level	-99 to ±0 to +99	Specifies the skin detail level.
	Saturation	-99 to ±0 to +99	Specifies the saturation of the color targeted by skin detail correction.
	Hue	0 to 359	Specifies the hue of the color targeted by skin detail correction.
	Width	0 to 40 to 90	Specifies a range for the hue of the color targeted by skin detail correction.
Matrix Makes settings related to matrix correction. Matrix correction allows you to adjust the color and vividness of the video. Depending on the effect you want, you can select one from among a number of preset matrixes, which define different parameter sets. Or you can select a user matrix with your own parameters.	Matrix	On/Off	Turns the matrix correction function on or off.
	Preset Matrix	On/Off	Turns the preset matrix function on or off.
	Preset Select	1/2/3/4/5/6	Selects a preset matrix. 1: SMPTE-240M equivalent 2: ITU-709 equivalent 3: SMPTE WIDE equivalent 4: NTSC equivalent 5: EBU equivalent 6: PAL equivalent
	User Matrix	On/Off	Turns the user matrix function on or off.
	User Matrix R-G	-99 to ±0 to +99	Specifies a freely defined R-G user matrix.
	User Matrix R-B	-99 to ±0 to +99	Specifies a freely defined R-B user matrix.
	User Matrix G-R	-99 to ±0 to +99	Specifies a freely defined G-R user matrix.
	User Matrix G-B	-99 to ±0 to +99	Specifies a freely defined G-B user matrix.
	User Matrix B-R	-99 to ±0 to +99	Specifies a freely defined B-R user matrix.
	User Matrix B-G	-99 to ±0 to +99	Specifies a freely defined B-G user matrix.

PAINT			
Menu items	Sub-item	Settings	Description
Multi Matrix Makes settings related to multi matrix correction. Multi-matrix correction allows specific colors to be selected for saturation correction in a 16-axis hue space.	Multi Matrix	On/Off	Turns the multi matrix correction function on or off.
	Area Indication	On/Off	Turns on or off the function that displays a zebra pattern in the color area targeted by multi matrix correction.
	Color Detection	Color detection screen	Detects colors targeted by multi matrix correction.
	Axis	B/B+/MG-/MG/MG+/R/R+/YL-/YL/YL+/G-/G/G+/CY/CY+/B-	Specifies a color targeted by multi matrix correction (16-axis mode)
	Hue	-99 to ±0 to +99	Specifies the hue of the color targeted by multi matrix correction for each 16-axis mode.
	Saturation	-99 to ±0 to +99	Specifies the saturation of the color targeted by multi matrix correction for each 16-axis mode.
V Modulation Makes settings related to V modulation shading. V modulation shading corrects vertical imbalances in sensitivity arising from the relationship between a lens and prism.	V Modulation	On/Off	Turns V modulation shading on or off.
	Master V Modulation	-99 to ±0 to +99	Specifies the master V modulation level.
	R V Modulation	-99 to ±0 to +99	Specifies the V modulation level of R signals.
	G V Modulation	-99 to ±0 to +99	Specifies the V modulation level of G signals.
	B V Modulation	-99 to ±0 to +99	Specifies the V modulation level of B signals.
Low Key Sat. Makes settings related to low key saturation correction. You can correct the saturation of colors in dark parts of the video only.	Low Key Saturation	On/Off	Turns low key saturation correction on or off.
	Level	-99 to ±0 to +99	Specifies the saturation of colors in low luminance areas.
	Range	Low/L Mid/H.Mid/ High	Specifies the luminance level for which low key saturation is enabled.
Noise Suppress Makes settings related to noise suppression (noise compression). You can effectively suppress noise components while preserving fine edge components in the subject.	Noise Suppress	On/Off	Turns noise suppression on or off.

MAINTENANCE Menu

Settings in bold are the factory default values.

MAINTENANCE			
Menu items	Sub-item	Settings	Description
White Shading Makes settings related to white shading. White shading is required for each different lens to correct irregularities arising from lens characteristics. It corrects luminance and color irregularities in bright areas.	Channel Select	Red/Green/Blue	Selects the target of white shading correction.
	R/G/B White H Saw	-99 to ±0 to +99	Specifies a SAW white shading correction value for the horizontal direction.
	R/G/B White H Para	-99 to ±0 to +99	Specifies a parabola white shading correction value for the horizontal direction.
	R/G/B White V Saw	-99 to ±0 to +99	Specifies a SAW white shading correction value for the vertical direction.
	R/G/B White V Para	-99 to ±0 to +99	Specifies a parabola white shading correction value for the vertical direction.
	White Saw/Para	On/Off	Turns the white shading SAW and parabola correction functions on or off.
Black Shading Makes settings related to black shading correction.	Channel Select	Red/Green/Blue	Selects the target of black shading correction.
	R/G/B Black H Saw	-99 to ±0 to +99	Specifies a SAW black shading correction value for the horizontal direction.
	R/G/B Black H Para	-99 to ±0 to +99	Specifies a parabola black shading correction value for the horizontal direction.
	R/G/B Black V Saw	-99 to ±0 to +99	Specifies a SAW black shading correction value for the vertical direction.
	R/G/B Black V Para	-99 to ±0 to +99	Specifies a parabola black shading correction value for the vertical direction.
	Black Saw/Para	On/Off	Turns the black shading SAW and parabola correction functions on or off.
	Master Black	-99 to ±0 to +99	Specifies the master black level.
Master Gain (TMP)	-6dB/-3dB/0dB/3dB/6dB/9dB/12dB/18dB/24dB/30dB/36dB/42dB	Specifies a temporary master gain value.	
Battery Makes settings related to batteries.	Info Before End	5% /10%/15%...95%/100%	Specifies a threshold value that triggers a "Battery Near End" warning when a BP-GL65/GL95 battery pack is used.
	Info End	0% /1%/2%/3%/4%/5%	Specifies a threshold value that triggers a "Battery End" warning when a BP-GL65/GL95 battery pack is used.

MAINTENANCE

Menu items	Sub-item	Settings	Description
Battery Makes settings related to batteries.	Sony Before End	11.5V to 17V (0.1V step)	Specifies a threshold value that triggers a “Battery Near End” warning when a BP-L60S/L80S battery pack is used.
	Sony End	11.0V to 11.5V (0.1V step)	Specifies a threshold value that triggers a “Battery End” warning when a BP-L60S/L80S battery pack is used.
	Other Before End	11.5V to 11.8V to 17.0V (0.1V step)	Specifies a threshold value that triggers a “Battery Near End” warning when a non-Sony battery pack is used.
	Other End	11.0V to 14.0V (0.1V step)	Specifies a threshold value that triggers a “Battery End” warning when a non-Sony battery pack is used.
	DC In Before End	11.5V to 11.8V to 17.0V (0.1V step)	Specifies a threshold value that triggers a “Battery Near End” warning when an external power source is connected to the DC IN connector.
	DC In End	11.0V to 14.0V (0.1V step)	Specifies a threshold value that triggers a “Battery End” warning when an external power source is connected to the DC IN connector.
	Detected Battery	Info/Sony/Other/DC IN	Displays the results of automatic battery pack type detection.
	Type Detection	Auto /Other	Auto: Detect the battery type automatically. Other: Fix battery type detection as “Other”.
	Segment No.10	11.0V to 17.0V (0.1V step)	Specify voltage threshold values that cause remaining capacity segments to go off in the display of remaining battery capacity (<i>see page 32</i>). (The segments go off below the specified value.) These values are used when the battery type has been found to be “Other”.
	Segment No.9	11.0V to 16.0V to 17.0V (0.1V step)	
Segment No.8	11.0V to 15.0V to 17.0V (0.1V step)		
Segment No.7	11.0V to 14.0V to 17.0V (0.1V step)		
Segment No.6	11.0V to 13.5V to 17.0V (0.1V step)		
Segment No.5	11.0V to 13.0V to 17.0V (0.1V step)		
Segment No.4	11.0V to 12.5V to 17.0V (0.1V step)		
Segment No.3	11.0V to 12.0V to 17.0V (0.1V step)		
Segment No.2	11.0V to 11.5V to 17.0V (0.1V step)		
Segment No.1	11.0V to 17.0V (0.1V step)		

MAINTENANCE

Menu items	Sub-item	Settings	Description
Audio Makes settings related to audio.	Front MIC Select	Mono/ Stereo	Selects whether the front microphone is monaural (Mono) or stereo (Stereo).
	Audio CH3/4 Mode	Ch1/2 / Switch	Selects the input signals for the AUDIO IN CH-3/CH-4 connectors. Ch1/2: The same signals as the AUDIO IN CH-1/ CH-2 connectors. Switch: The signals selected with the AUDIO IN CH3/CH4 switches.
	Rear XLR Auto	On/ Off	Turns on or off the XLR connection automatic detection (for the AUDIO IN CH-1/CH-2 connectors on the rear panel).
	Front MIC CH1 Ref	-70dB/-60dB/ -50dB / -40dB/-30dB/-20dB	Selects the reference level for channel 1 of the front microphone.
	Front MIC CH2 Ref	-70dB/-60dB/ -50dB / -40dB/-30dB/-20dB	Selects the reference level for channel 2 of the front microphone.
	Rear MIC CH1 Ref	-70dB/ -60dB / -50dB / -40dB/-30dB/-20dB	Selects the reference input level when the setting of the AUDIO IN CH1 switch is MIC.
	Rear MIC CH2 Ref	-70dB/ -60dB / -50dB / -40dB/-30dB/-20dB	Selects the reference input level when the setting of the AUDIO IN CH2 switch is MIC.
	Line Input Ref	+4dB /0dB/-3dB/EBUL	Selects the reference input level when the AUDIO IN CH1 and AUDIO IN CH2 switches are set to LINE.
	Min Alarm Volume	Off /Set	Selects the volume when the ALARM knob is turned all the way down. Off: Almost inaudible Set: Fairly audible
	Speaker Attenuate	Off /3dB/6dB/9dB/12dB	Selects the volume from the monitor speakers (does not affect earphone volume).
	Headphone Out	Mono /Stereo	Selects whether the earphones are monaural (Mono) or stereo (Stereo).
	Reference Level	-20dB /-18dB/-16dB/ -12dB/EBUL	Selects the output level of the 1 kHz test signal.
	Reference Out	0dB /+4dB/-3dB/EBUL	Specifies the output level with respect to the reference input level.
	CH1&2 AGC Mode	Mono /Stereo	For automatic adjustment of the input level of analog audio signals recorded on channels 1 and 2, specifies whether to make the adjustments separately for each channel (Mono) or in stereo mode (Stereo).

MAINTENANCE

Menu items	Sub-item	Settings	Description
Audio Makes settings related to audio.	CH3&4 AGC Mode	Mono /Stereo	For automatic adjustment of the input level of analog audio signals recorded on channels 3 and 4, specifies whether to make the adjustments separately for each channel (Mono) or in stereo mode (Stereo).
	AGC Spec	-6dB /-9dB/-12dB/ -15dB/-17dB	Selects the AGC saturation level.
	Limiter Mode	Off /-6dB/-9dB/-12dB/ -15dB/-17dB	For manual audio level adjustments, selects the saturation level for the limiter applied to loud input signals. Select Off if you do not wish to use the limiter.
	Output Limiter	On/Off	Turns the audio output limiter on or off.
	CH1 Wind Filter	On/Off	Turns the channel 1 wind filter on or off.
	CH2 Wind Filter	On/Off	Turns the channel 2 wind filter on or off.
	CH3 Wind Filter	On/Off	Turns the channel 3 wind filter on or off.
	CH4 Wind Filter	On/Off	Turns the channel 4 wind filter on or off.
	Audio SG (1KHz)	On/Off /Auto	Selects whether to output (On) or not output (Off) a 1 kHz test signal in color bar mode. Auto: Output a test signal only when the AUDIO SELECT CH1 switch is set to AUTO .
	MIC CH1 Level	Side1/ Front /Front+Side1	For recording input audio from the front microphone on channel 1, selects the knob that adjusts the audio level. Side1: The LEVEL knob (left) on the side panel Front: The MIC LEVEL control on the front panel Front+Side1: Adjust with both the LEVEL knob (left) and the MIC LEVEL control.
	MIC CH2 Level	Side2/ Front /Front+Side2	For recording input audio from the front microphone on channel 2, selects the knob that adjusts the audio level. Side2: The LEVEL knob (right) on the side panel Front: The MIC LEVEL control on the front panel Front+Side2: Adjust with both the LEVEL knob (right) and the MIC LEVEL control.

MAINTENANCE

Menu items	Sub-item	Settings	Description
Audio Makes settings related to audio.	Rear1/WRR Level	Side1 /Front/Front+Side1	<p>Selects the knob that adjusts the audio levels of a wireless microphone and a device connected to the AUDIO IN CH-1 connector on the rear panel.</p> <p>Side1: The LEVEL knob (left) on the side panel</p> <p>Front: The MIC LEVEL control on the front panel</p> <p>Front+Side1: Adjust with both the LEVEL knob (left) and the MIC LEVEL control.</p>
	Rear2/WRR Level	Side2 /Front/Front+Side2	<p>Selects the knob that adjusts the audio levels of a wireless microphone and a device connected to the AUDIO IN CH-2 connector on the rear panel.</p> <p>Side2: The LEVEL knob (right) on the side panel</p> <p>Front: The MIC LEVEL control on the front panel</p> <p>Front+Side2: Adjust with both the LEVEL knob (right) and the MIC LEVEL control.</p>
	Audio CH3 Level	Side3 /Front/Front+Side3	<p>Selects the knob that adjusts the level of audio recorded on channel 3.</p> <p>Side3: The LEVEL knob on side panel</p> <p>Front: The MIC LEVEL control on the front panel</p> <p>Front+Side3: Adjust with both the LEVEL knob and the MIC LEVEL control.</p>
	Audio CH4 Level	Side4 /Front/Front+Side4	<p>Selects the knob that adjusts the level of audio recorded on channel 4.</p> <p>Side4: The LEVEL knob on side panel</p> <p>Front: The MIC LEVEL control on the front panel</p> <p>Front+Side4: Adjust with both the LEVEL knob and the MIC LEVEL control.</p>

MAINTENANCE

Menu items	Sub-item	Settings	Description
WRR Setting Makes settings related to the wireless tuner.	WRR Valid CH Sel	All/CH1	Selects whether to enable channels 1 and 2 of the wireless receiver (All) or channel 1 only (CH1).
	WRR CH Select	TX1/TX2	Specifies the target channel for other sub-items. TX1: Channel 1 TX2: Channel 2
	WRR Delay Comp	On/Off	Enables (On) or disables (Off) delay compensation for wireless audio input. (When On is selected, the audio in all E-E output is delayed by about 8 ms.)
	TX	---	Displays the name of the transmitter whose signals are being received on the channel selected by WRR CH SELECT.
	TX Audio Peak	---/Peak	Displays whether the AF level of the transmitter whose signals are being received on the channel selected by WRR CH SELECT are over peak.
	TX Input Level	---/Mic/Line	Displays whether the input level of the transmitter whose signals are being received on the channel selected by WRR CH SELECT is set to microphone (Mic) or line (Line).
	TX ATT Level	---	Sets the ATT level of the transmitter whose signals are being received on the channel selected by WRR CH SELECT. (The setting range varies depending on the transmitter.)
	TX LCF Frequency	---	Sets the low cut filter frequency of the transmitter whose signals are being received on the channel selected by WRR CH SELECT. (The setting range varies depending on the transmitter.)
	TX System Delay	Auto/0.0ms to 8.0ms	Specifies the amount of audio delay. Auto: Automatically adjusts the amount of delay so that the delay in the audio received from the wireless transmitter is zero. 0.0ms to 8.0ms: Sets the amount of anticipated wireless system delay, for cases in which several wireless systems are being used over a devices such as an audio mixer.

MAINTENANCE			
Menu items	Sub-item	Settings	Description
Timecode Makes settings related to timecode.	TC Out	Auto /Generator	Selects the source for timecode output. Auto: During recording, output values generated by the timecode generator, and during playback output values obtained by the timecode reader. Generator: Output values generated by the timecode generator during both recording and playback.
	DF/NDF	DF /NDF	When the Country setting is other than [PAL Area], selects drop-frame mode (DF) or non-drop-frame mode (NDF).
	LTC UBIT	Fix /Time	Specifies the data recorded in LTC user bits. Fix: Record user-specified data. Time: Record the current time.
	Counter Display	Counter /Duration	Select the method used to reset the counter value displayed on the viewfinder screen. Counter: Continue to increment until the RESET button is pressed. Duration: Reset each time that recording is started.
Essence Mark Makes settings related to shot marks and clip index picture thumbnails.	Ret Shot Mark 1	On /Off	Specify whether to input Shot Mark1 marks using the RET button on the lens.
	Ret Shot Mark 2	On /Off	Specify whether to input Shot Mark2 marks using the RET button on the lens.
	Index Pic Pos	0sec to 10sec (in 1 sec steps)	Specifies which frame to use as the clip thumbnail image
	Find Mode	Clip/Rec Start	Specify the frame to be cued up when the PREV or NEXT button is pressed. Rec Start: The next frame or the previous frame where a Rec Start essence mark is set. Clip: Pressing the NEXT button moves to the start frame of the next clip. Pressing the PREV button moves to the start frame of the current clip. (Pressing the PREV button at the start frame of the current clip moves to the start frame of the previous clip.)

MAINTENANCE

Menu items	Sub-item	Settings	Description
Camera Config Makes settings related to various camcorder operations.	Rec Tally Blink	On/Off	Turns warning flashes by the TALLY indicator on or off. The warnings alert you an almost exhausted battery pack or low remaining media capacity.
	Rec Review	3sec/10sec/Clip	Selects the recording review time. Clip: Review all of the most recently recorded clip.
	HD SDI Remote I/F	Off/Chara/G-Tally/R-Tally	Selects whether to use the function that enables recording control from this camcorder of an external device connected to the HD/SD SDI OUT connector (HDSDI output). When the function is used, also selects the indication that shows whether the external device is recording. Off: Do not use the remote recording control function. Chara: Indicate by the external device control indication on the viewfinder screen. G-Tally: Indicate by the green tally indicator in the HDVF series viewfinder or green tally indicator on the screen of the CBK-VF01 viewfinder. R-Tally: Indicate by the recording/red tally indicators in the HDVF series viewfinder or the special recording mode/operation status indication on the screen of the CBK-VF01 viewfinder.
	Color Bars Select	ARIB/100%/75%/SMPTE	Selects the color bar type.
	User Menu Only	On/Off	Selects whether to display the USER menu only (On) or display the menu list (Off) when the camcorder enters the menu mode.
RM Common Memory	On/Off	Selects whether to share (On) or not share (Off) settings between times when a remote control unit is connected and times when the camcorder is used locally.	

Note

When a remote control unit is connected, this setting is disabled.

MAINTENANCE			
Menu items	Sub-item	Settings	Description
Camera Config Makes settings related to various camcorder operations.	RM Rec Start	RM /CAM/PARA	For times when a remote control unit is connected, selects whether recording start/stop buttons are enabled on the camcorder or the remote control unit. RM: Remote control unit CAM: Camcorder PARA: Both
	Preset White Makes settings related to white balance preset values.	Color Temp<P>	1500K to 3200K to 5000K
	Color Temp Balance<P>	-99 to ±0 to +99	Specifies finer color temperature settings, for use when satisfactory video cannot be obtained with Color Temp<P>.
	R Gain <P>	-99 to ±0 to +99	Specifies the R gain preset value.
	B Gain <P>	-99 to ±0 to +99	Specifies the B gain preset value.
	AWB Enable <P>	On/ Off	Turns on and off execution of the AWB (auto white balance) function when the WHITE BAL switch is set to PRST.
White Filter Makes settings related to filters.	ND Filter	On/ Off	Turns the function that assigns electrical CC filters to ND filters on or off.
	C.Temp		
	ND FLT C.Temp<1>	3200K /4300K/5600K/6300K	Selects the color temperature for when electrical CC filters are assigned to ND filters.
	ND FLT C.Temp<2-4>	3200K/4300K/ 5600K /6300K	Selects the color temperature for when electrical CC filters are assigned to ND filters.
	Electrical CC<A>	3200K /4300K/5600K/6300K	Selects the color temperature for when the electrical CC filter switching function is assigned to an assignable switch.
	Electrical CC	3200K/ 4300K /5600K/6300K	Selects the color temperature for when the electrical CC filter switching function is assigned to an assignable switch.
	Electrical CC<C>	3200K/4300K/ 5600K /6300K/-----	Selects the color temperature for when the electrical CC filter switching function is assigned to an assignable switch. Select “-----” if you do not want to use C.
	Electrical CC<D>	3200K/4300K/5600K/ 6300K /-----	Selects the color temperature for when the electrical CC filter switching function is assigned to an assignable switch. Select “-----” if you do not want to use D.

MAINTENANCE

Menu items	Sub-item	Settings	Description
DCC Adjust Makes settings related to DCC (dynamic contrast control).	DCC Function Select	DCC/Fix	Enables or disables automatic knee point adjustment when the OUTPUT/DCC switch is set to CAM, DCC: ON. DCC: Automatically adjust the knee point according to the luminance of the subject. Fix: Set the knee point to a fixed value.
	DCC D Range	400%/450%/500%/550%/ 600%	Specifies the dynamic range when the OUTPUT/DCC switch is set to CAM, DCC: ON.
	DCC Point	-99 to ±0 to +99	Adjusts the DCC minimum knee point.
	DCC Gain	-99 to ±0 to +99	Specifies gain with respect to the DCC detected value.
	DCC Delay Time	-99 to ±0 to +99	Specifies the DCC control speed (speed of reaction to changes in the video).
	DCC Peak Filter	-99 to ±0 to +99	Adjusts response sensitivity with respect to peaks in DCC detected values.

MAINTENANCE			
Menu items	Sub-item	Settings	Description
Auto Iris2 Makes settings related to auto iris.	Iris Window	1/2/3/4/5/6/Var	Selects the type of iris detection window. Var: Variable
	Iris Window Ind	On/Off	Turns on or off the function that displays a frame marker for the auto iris detection window.
	Iris Level	-99 to ± 0 to +99	Adjusts the level of the auto iris target value.
	Iris APL Ratio	-99 to ± 0 to +99	Adjusts the mix ratio of auto iris detection peak value and average value (available when OPERATION >TLCS >Mode is set to [Standard]).
	Iris Var Width	40 to 500 to 999	Adjusts the width of the detection window when the setting of Iris Window is VAR.
	Iris Var Height	70 to 500 to 999	Adjusts the height of the detection window when the setting of Iris Window is VAR.
	Iris Var H Position	-479 to 0 to +479	Specifies the horizontal position of the detection window when the setting of Iris Window is VAR.
	Iris Var V Position	-464 to 0 to +464	Specifies the vertical position of the detection window when the setting of Iris Window is VAR.
	Iris Speed	-99 to ± 0 to +99	Specifies the control speed (speed of reaction to changes in the video). (Larger values specify quicker reaction times.)
	Clip High Light	On/Off	Turns on or off the function that disregards highlights and forces a flatter reaction to high luminance.
Genlock Makes settings related to genlock.	Genlock	On/Off	Turns the genlock function on or off.
	H Phase(HD)	-999 to ± 0 to +999	Specifies the H phase of HD output when genlock is enabled.
	H Phase(SD)	-99 to ± 0 to +99	Specifies the H phase of SD output when genlock is enabled.
	Reference	Internal/Genlock	Displays the type of reference signal used by the camcorder.

MAINTENANCE			
Menu items	Sub-item	Settings	Description
ND Comp Makes settings related to ND filter color compensation. Although the differences are very slight, each of the built-in ND filters has different color characteristics. When you switch between ND filters, the white balance may be disturbed. You can correct for these slight color differences automatically by registering compensation values for each filter.	ND Offset Adjust	On/Off	ND filter color compensation function.
	Clear ND Offset	Execute/Cancel	Clears ND filter color compensation values (execute by selecting Execute).
Lens Executes auto flange back adjustment.	Auto FB Adjust	Execute/Cancel	Executes auto flange back adjustment, only for supported lenses (execute by selecting Execute).
Auto Shading Executes auto black shading compensation.	Auto Black Shading	Execute/Cancel	Executes auto shading compensation (execute by selecting Execute).
	Reset Black Shading	Execute/Cancel	Clears black shading compensation values (execute by selecting Execute).
	Master Gain (TMP)	-6dB/-3dB/0dB/3dB/ 6dB/9dB/12dB/18dB/ 24dB/30dB/36dB/42dB	
APR	APR(SLS)	Execute/Cancel	Suppresses white flecks in SLS mode by executing the automatic pixel noise reduction function (execute by selecting Execute).
	APR Preset	Execute/Cancel	Deletes white flecks data that was added by execution of the APR and automatic black balance adjustment functions (execute by selecting Execute).
Trigger Mode Makes settings related to triggers for starting and stopping recording.	i.LINK Trigger Mode	Internal/Both/External	Select Internal when recording start and stop operations target SxS memory cards only. Select External when they target only devices connected to the i.LINK (HDV/DV) or HD/SD SDI OUT connectors. Select Both when they target both memory cards and external devices.

MAINTENANCE			
Menu items	Sub-item	Settings	Description
Network Setting ^{b)} Makes settings for network connection. Notes <ul style="list-style-type: none"> The CBK-WA01 Wi-Fi Adapter is required. This item is disabled (displayed in grey) during recording and play. <i>For details on network connection, refer to the Supplement supplied in the CD-ROM (labeled "Manuals for Solid-State Memory Camcorder").</i>	DHCP	Enable/Disable	Selects whether to acquire the IP address automatically from a DHCP server (Enable) or not (Disable).
	IP Address	0.0.0.0 to 255.255.255.255 (192.168.1.10)	When DHCP is set to [Disable], sets the IP address.
	Subnet Mask	0.0.0.0 to 255.255.255.255	When DHCP is set to [Disable], sets the subnet mask.
	Default Gateway	0.0.0.0 to 255.255.255.255	When DHCP is set to [Disable], sets the default gateway.
	User Name	admin	Sets a desired user name in 1 to 31 alphanumeric characters.
	Password	pmw-500 (model name)	Sets a password (model name) in 0 to 31 alphanumeric characters.
	Set	Execute/Cancel	Confirms the settings in Network Settings (execute by selecting [Execute]).
	MAC Address		Displays the MAC address.
	Net Config Reset	Execute/Cancel	Resets the settings in Network Settings to the preset values (execute by selecting [Execute]).
	Wi-Fi Setting ^{b)} Makes settings for Wi-Fi connection. Notes <ul style="list-style-type: none"> The CBK-WA01 Wi-Fi Adapter is required. This item is disabled (displayed in grey) during recording and play. <i>For details on Wi-Fi connection, refer to the Supplement supplied in the CD-ROM (labeled "Manuals for Solid-State Memory Camcorder").</i>	Scan Networks	Execute/Cancel
SSID		Network connection name	Sets the network connection name of up to 32 characters.
Network Type		Infra/Adhoc	Selects the connection mode. Infra: Infrastructure mode Adhoc: Ad hoc mode
Ch		1 to 11	When Network Type is set to [Adhoc], set the wireless channel.
Authentication		Open/Shared/WPA/WPA2	Selects the network authentication. OPEN: Open system authentication SHARED: Shared key authentication WPA: WPA (Wi-Fi Protected Access) authentication WPA2: WPA2 (Wi-Fi Protected Access 2) authentication

MAINTENANCE

Menu items	Sub-item	Settings	Description
Wi-Fi Setting ^{b)} Makes settings for Wi-Fi connection.	Encryption	Disable /WEP/TKIP/AES	Selects whether to apply data encryption and the type of data encryption. Disable: Do not apply data encryption. WEP: Apply WEP (Wired Equivalent Privacy) when Authentication is set to [Open] or [Shared] TKIP: Apply TKIP (Temporal Key Integrity Protocol) when Authentication is set to [WPA] or [WPA2] AES: Apply AES (Advanced Encryption Standard) when Authentication is set to [WPA] or [WPA2]
Notes			
<ul style="list-style-type: none"> • The CBK-WA01 Wi-Fi Adapter is required. • This item is disabled (displayed in grey) during recording and play. <p><i>For details on Wi-Fi connection, refer to the Supplement supplied in the CD-ROM (labeled “Manuals for Solid-State Memory Camcorder”).</i></p>			
	WEP Key Index	1/2/3/4	When Encryption is [WEP], selects the key index.
	Input Select	When Encryption is set to [WEP]: ASCII5 , ASCII13, HEX10, HEX26 When Encryption is set to [TKIP] or [AES]: ASCII8-63, HEX64	Selects the input format depending on the network key (or security key). ASCII5: Five characters ASCII format ASCII13: 13 characters ASCII format HEX10: 10 hexadecimal digits HEX26: 26 hexadecimal digits ASCII8-63: 8 to 63 characters ASCII 8-bit format HEX64: 64 hexadecimal digits (characters)
	Key		Sets the network key (or security key).
	Set		Enables settings for Wi-Fi Setting when Wi-Fi is set to [Enable] (execute by selecting [Execute]).
	Wi-Fi Status	■■■■■ Connecting	Displays “Connecting” while connection is being attempted. Displays black squares to show the connection status by the number of squares when the camcorder is connected to a computer or a LAN.
	Wireless Mode	802.11b/802.11g/802.11n	Displays an IEEE802.11 standard.
	Wi-Fi	Enable/ Disable	Selects whether to enable or disable Wi-Fi connection.

MAINTENANCE			
Menu items	Sub-item	Settings	Description
Clock Set Sets the internal clock.	Date/Time	12H/24H	Sets the current date and time.
			Selects the 12-hour format (12H) or the 24-hour format (24H) for display of times.
	Date Mode	YYMMDD/MMDDYY/ DDMMYY	Selects the display format for dates. YYMMDD: Year, Month, Day MMDDYY: Month, Day, Year DDMMYY: Day, Month Year
Language Selects the language for messages.	Language	English/Chinese	Selects the language for messages from English or Chinese.
Hours Meter Makes settings related to the digital hours meter.	Hours(Sys)		Displays the cumulative hours of use (cannot be reset).
	Hours(Reset)		Displays the hours of use (can be reset).
	Reset	Execute/Cancel	Resets Hours(Reset) to 0. (Execute by selecting Execute.)
Version Displays the version of the camcorder, and updates the camcorder.	Version		Displays the software version of the camcorder (Vx.xx).
	CBK-HD02 ^{a)}		Displays the software version of the CBK-HD02 (Vx.xx).
	Version Up	Execute/Cancel	Updates the camcorder (execute by selecting Execute).
			<p>Note</p> <p>This cannot be selected unless an SxS memory card is inserted.</p>

a) When the optional CBK-HD02 is installed

b) When the optional CBK-UPG01 is installed

FILE Menu

Settings in bold are the factory default values.

FILE			
Menu items	Sub-item	Settings	Description
User Makes settings for operating user files.	User Load SxS	Execute/Cancel	Loads a user file from an SxS memory card (execute by selecting [Execute]). When Load Customize Data is set to [Off]: Replace the current USER menu settings with settings stored in the loaded use file (with the original menu configuration unchanged). When Load Customize Data is set to [On]: Replace the current USER menu configuration and settings with those stored in the loaded use file. When User Load White is set to [Off]: Load a user file excluding white balance data. User Load White is set to [On]: Load a user file including white balance data.
	User Save SxS	Execute/Cancel	Stores the current USER menu configuration and settings including the white balance data to an SxS memory card as a user file (execute by selecting [Execute]).
	User Load USB (in UDF mode only)		Loads a user file from a USB flash drive (execute by selecting [Execute]).
	User Save USB (in UDF mode only)		Stores the current USER menu configuration and settings including the white balance data to a USB flash drive as a user file (execute by selecting [Execute]).
	File ID		Assigns a name to a file. Names can be up to 16 characters in length.
	Recall User Preset	Execute/Cancel	Returns the current USER menu settings to the preset values (execute by selecting [Execute]).
	Store User Preset	Execute/Cancel	Stores the USER menu as a user file in which all menu settings are reset to the preset values (execute by selecting [Execute]).
	Clear User Preset	Execute/Cancel	Returns the current USER menu settings to the factory default settings (execute by selecting [Execute]).

FILE			
Menu items	Sub-item	Settings	Description
User Makes settings for operating user files.	Load Customize Data	Off/On	Selects whether to load both menu configuration and settings (On) or load only menu settings (Off) white balance data when loading a user file.
User Makes settings for operating user files.	Load White Data	Off/On	Selects whether to load (On) or not load (Off) white balance data when loading a user file.
All Makes settings related to ALL file operations.	Display Mode	Date&Time/Model Name	Selects the items to be displayed in the list box that appears when a file is saved or loaded.
	All Load(SxS)	Execute/Cancel	Loads an ALL file from an SxS memory card (execute by selecting Execute).
	All Save(SxS)	Execute/Cancel	Stores an ALL file to an SxS memory card (execute by selecting Execute).
	All Load(USB) (in UDF mode only)	Execute/Cancel	Loads an ALL file from a USB flash drive (execute by selecting [Execute]).
	All Save(USB) (in UDF mode only)	Execute/Cancel	Stores an ALL file to a USB flash drive (execute by selecting [Execute]).
	File ID		Assigns a name to a file. Names can be up to 16 characters in length.
	All Preset	Execute/Cancel	Returns all items to their preset values (execute by selecting Execute).
	Store All Preset	Execute/Cancel	Stores the current settings of all items as the preset values (execute by selecting [Execute]).
	Clear All Preset	Execute/Cancel	Clears the preset values of all items (execute by selecting [Execute]).
	3Sec Clr Preset	On/Off	Turns on or off the function that clears each preset value when the MENU CANCEL/PRST/ESCAPE switch is pushed up and held for three seconds on the CANCEL/PRST side.
	Network Data	Off/On	Selects whether to load (On) or not load (Off) network settings when loading an ALL file.

FILE			
Menu items	Sub-item	Settings	Description
Scene Makes settings related to scene file operations.	<input type="checkbox"/> 1	Standard	File number and file ID
	<input type="checkbox"/> 2	Standard	File number and file ID
	<input type="checkbox"/> 3	Standard	File number and file ID
	<input type="checkbox"/> 4	Standard	File number and file ID
	<input type="checkbox"/> 5	Standard	File number and file ID
	<input type="checkbox"/> Standard		Standard settings
	Display Mode	Date&Time /Model Name	Selects the items to be displayed in the list box that appears when a file is saved or loaded.
	Scene Recall Mem	Execute/Cancel	Loads a file from internal memory (execute by selecting [Execute]).
	Scene Store Mem	Execute/Cancel	Stores a file in internal memory (execute by selecting [Execute]).
	Scene Recall SxS	Execute/Cancel	Loads a file from an SxS memory card (execute by selecting [Execute]).
	Scene Store SxS	Execute/Cancel	Stores a file to an SxS memory card (execute by selecting [Execute]).
	Scene Recall USB (in UDF mode only)	Execute/Cancel	Loads a file from a USB flash drive (execute by selecting [Execute]).
	Scene Store USB (in UDF mode only)	Execute/Cancel	Stores a file to a USB flash drive (execute by selecting [Execute]).
	File ID		Assigns a name to a file. Names can be up to 16 characters in length.
Reference Makes settings related to reference file operations.	Reference Store	Execute/Cancel	Stores the current settings of reference file items in the reference file that is maintained in internal memory (execute by selecting [Execute]).
	Reference Clear	Execute/Cancel	Clear the reference file (execute by selecting [Execute]).
	Refer Load(SxS)	Execute/Cancel	Load a reference file from an SxS memory card (execute by selecting [Execute]).
	Refer Save(SxS)	Execute/Cancel	Store a reference file to an SxS memory card (execute by selecting [Execute]).
	Refer Load(USB) (in UDF mode only)	Execute/Cancel	Loads a file from a USB flash drive (execute by selecting [Execute]).
	Refer Store(USB) (in UDF mode only)	Execute/Cancel	Stores a file to a USB flash drive (execute by selecting [Execute]).
	File ID		Assigns a name to a file. Names can be up to 16 characters in length.
	Scene White Data	On/Off	Selects whether to load (On) or not load (Off) white balance data when Scene >Scene Recall or Scene >Standard is executed.

FILE			
Menu items	Sub-item	Settings	Description
Lens Makes settings related to lens file operations.	Display Mode	Date&Time/Model Name	Selects the items to be displayed in the list box that appears when a file is saved or loaded.
	Lens Recall Mem	Execute/Cancel	Loads a file from internal memory (execute by selecting [Execute]).
	Lens Store Mem	Execute/Cancel	Stores a file in internal memory (execute by selecting [Execute]).
	Lens Recall SxS	Execute/Cancel	Loads a file from an SxS memory card (execute by selecting [Execute]).
	Lens Store SxS	Execute/Cancel	Stores a file to an SxS memory card (execute by selecting [Execute]).
	Lens Recall USB (in UDF mode only)	Execute/Cancel	Loads a file from a USB flash drive (execute by selecting [Execute]).
	Lens Store USB (in UDF mode only)	Execute/Cancel	Stores a file to a USB flash drive (execute by selecting [Execute]).
	File ID		Assigns a name to the most recently loaded file. Names can be up to 16 characters in length.
	Source		Displays the number of the selected file.
	Lens No Offset	Execute/Cancel	Clears a file (execute by selecting [Execute]).
	Lens Auto Recall	Off/On/Serial Number	When the installed lens supports serial communication, specifies whether to automatically load that reference file. Off: Do not use this function. On: Load the reference for the model name and reflect the contents of the file. Serial Number: For lenses that support serial number communication, load the lens file that corresponds to the serial number and model name, and reflect the contents of that file. For lenses that do not support serial number communication, load the reference for the model name (in the same way as when On is selected).
	Serial Number		Displays the serial number of the installed lens (only for lenses that support serial communication).
	Lens ID		Displays the model name of the installed lens (only for lenses that support serial communication).

FILE			
Menu items	Sub-item	Settings	Description
Lens Makes settings related to lens file operations.	L Manufacturer		Displays the name of the manufacturer of the installed lens (only for lenses that support serial communication).
	M V Modulation	-99 to ± 0 to +99	Sets a vertical SAW shading compensation value in the lens file.
	Lens Center H	-40 to 0 to 40	Sets a center marker horizontal position in the lens file.
	Lens Center V	-40 to 0 to 40	Sets a center marker vertical position in the lens file.
	Lens R Flare	-99 to ± 0 to +99	Sets a R flare level in the lens file.
	Lens G Flare	-99 to ± 0 to +99	Sets a G flare level in the lens file.
	Lens B Flare	-99 to ± 0 to +99	Sets a B flare level in the lens file.
	Lens W-R Offset	-99 to ± 0 to +99	Sets a R white balance compensation value in the lens file.
	Lens W-B Offset	-99 to ± 0 to +99	Sets a B white balance compensation value in the lens file.
	Shading Ch Sel	Red /Green/Blue	Selects the white shading compensation target.
	L R/G/B H Saw	-99 to ± 0 to +99	Sets a horizontal SAW white shading compensation value in the lens file.
	L R/G/B H Para	-99 to ± 0 to +99	Sets a horizontal parabola white shading compensation value in the lens file.
	L R/G/B V Saw	-99 to ± 0 to +99	Sets a vertical SAW white shading compensation value in the lens file.
	L R/G/B V Para	-99 to ± 0 to +99	Sets a vertical parabola white shading compensation value in the lens file.

Assigning Functions to Assignable Switches

Using the Assignable SW item of the OPERATION menu, you can assign user-specified functions to the ASSIGN. 0 to 3 switches, the ASSIGNABLE 4 and 5 switches, the COLOR TEMP. button, and the RET button on the lens.

The following tables lists the functions that are assigned when the camcorder is shipped from the factory.

Switch or button	Function	Assignable SW setting
ASSIGN. 0 switch	No assignment	Off
ASSIGN. 1 switch	No assignment	Off
ASSIGN. 2 switch	No assignment	Off
ASSIGN. 3 switch	No assignment	Off
ASSIGNABLE 4 switch	No assignment	Off
ASSIGNABLE 5 switch	No assignment	Off
RET button	During recording or playback: Write a shot mark. In the other states: Conduct a recording review (if playback is allowed).	Lens RET
COLOR TEMP. button	Adjust the white balance with the preset white balance value of 5600K.	Color Temp SW 5600K

Functions That Can Be Assigned to the ASSIGN. 0 Switch

Assignable switch setting	Function	State when camcorder is next powered on
Off	No assignment	—
Marker	Turn the display of all markers on or off.	Setting retained
ATW Hold	Hold the white balance setting in the ATW (auto-tracking white balance) mode	—
Picture Cache	Turn the picture cache function on or off.	Setting retained
Freeze Mix	Execute the freeze mix function.	—
Focus Mag	Turn the focus magnification function on or off.	Setting not retained
Zebra	Turn zebra display on or off.	Setting not retained
Shot Mark1	Write Shot Mark1.	—
Shot Mark2	Write Shot Mark2.	—
OK Mark	Add or delete an OK mark.	—
Clip Flag OK	Add/clear an OK mark to/from the clip being recorded or played.	Setting not retained
Clip Flag NG	Add/clear an NG mark to/from the clip being recorded or played.	Setting not retained
Clip Flag Keep	Add/clear a KP mark to/from the clip being recorded or played.	Setting not retained

Functions That Can Be Assigned to the ASSIGN. 2 Switch

Note

Immediately after you assign a function to the ASSIGN. 2 switch or you switch the recording format, the setting of the switch at that point may not match the camcorder's internal state. After assigning a function, switch the ASSIGN. 2 switch or power the camcorder off and on again.

Assignable switch setting	Function
Off	No assignment
Front Mic	Switch between stereo and monaural when a stereo microphone is connected.
Marker	Turn the display of all markers on or off.
Picture Cache ^{a)}	Turn the picture cache function on or off.
Zebra	Turn zebra display on or off.
Clip Continuous Rec	Turn the Clip Continuous Rec mode on or off.
Digital Extender	Turn the screen magnification function on or off when the optional CBK-HD02 SDI/COMPOSITE Input and 50 Pin Interface is installed.
Rec Source	Switch the signals to be recorded between the camera picture and external input when the optional CBK-HD02 SDI/COMPOSITE Input and 50 Pin Interface is installed. (if the unit is currently conducting recording or play, the switch takes effect after the recording or playback ends.)

Note

- a) When Picture Cache is assigned, OPERATION >Rec Function in the setup menu is disabled (displayed in grey) to keep the setting unchanged.

Functions That Can Be Assigned to the ASSIGN. 1 and 3 Switches, the ASSIGNABLE 4 and 5 Switches, and the COLOR TEMP. Button

Assignable switch setting	Function	State when camcorder is next powered on
Off	No assignment	—
Front Mic	Switch between stereo (On) and monaural (Off) when a stereo microphone is connected.	Setting retained
Marker	Turn the display of all markers on or off.	Setting retained
Last Clip Delete	Delete the most recently recorded clip.	—
ATW	Turn ATW (auto tracing white balance) mode on or off.	Setting not retained
ATW Hold	Hold the white balance setting in the ATW mode.	—
EZ Mode	Execute EZ mode according to the setting of OPERATION >TLCS.	Setting retained
Turbo Gain	Execute Turbo Gain according to the setting of OPERATION >Gain Switch >Gain Turbo.	Setting not retained
Rec Review	Conduct a recording review.	—
Rec	Start or stop recording.	—
Picture Cache	Turn the picture cache function on or off.	Setting retained
Freeze Mix	Execute the freeze mix function.	Setting not retained
Spotlight	Turn the spotlight function in auto iris mode on or off.	Setting retained

Assignable switch setting	Function	State when camcorder is next powered on
Backlight	Turn the backlight function in auto iris mode on or off.	Setting retained
EVF Mode	Switch the viewfinder screen between B&W (On) and color (Off).	Setting retained
BRT Disp	Turn the display of the brightness level on or off.	Setting retained
Histogram	Turn the histogram display on or off.	Setting retained
Lens Info	Switch the depth of field indication between off, displayed in meters, and displayed in feet.	Setting retained
Zoom Tele/Wide	When a lens that supports serial communication is installed, assign the Zoom Tele function to ASSIGNABLE 4, and assign the Zoom Wide function to ASSIGNABLE 5 (displayed only when <4> and <5> are set).	—
Zoom Wide/Tele	When a lens that supports serial communication is installed, assign the Zoom Wide function to ASSIGNABLE 4, and assign the Zoom Tele function to ASSIGNABLE 5 (displayed only when <4> and <5> are set).	—
Manual Focus Assist	Turn the manual focus assist function on or off.	Setting retained
Focus Mag	Turn the focus magnification function on or off.	Setting not retained
Zebra	Turn zebra display on or off.	Setting not retained
Lens RET	Display return video signals when the optional CBK-HD02 is installed and a camera extension unit is connected. When a camera extension unit is not connected, function as follows. During recording or playback: Write a shot mark. In the other states: Conduct a recording review (if playback is allowed).	—
Return Video	Display return video signals when the optional CBK-HD02 is installed and a camera extension unit is connected.	—
Shot Mark1	Write Shot Mark1.	—
Shot Mark2	Write Shot Mark2.	—
OK Mark	Add or delete an OK mark.	—
Clip Flag OK	Add/Clear an OK mark to/from the clip being recorded or played.	Setting not retained
Clip Flag NG	Add/Clear an NG mark to/from the clip being recorded or played.	Setting not retained
Clip Flag Keep	Add/Clear a KP mark to/from the clip being recorded or played.	Setting not retained
Color Temp SW 3200K	Adjust the white balance with a 3200K preset value.	Setting retained
Color Temp SW 4300K	Adjust the white balance with a 4300K preset value.	Setting retained
Color Temp SW 5600K	Adjust the white balance with a 5600K preset value.	Setting retained
Color Temp SW 6300K	Adjust the white balance with a 6300K preset value.	Setting retained

Assignable switch setting	Function	State when camcorder is next powered on
Electrical CC	<p>Function that switches the electrical CC filter (3200K/4300K/5600K/6300K) applied to white balance adjustment values.</p> <p>Each press of the switch or button switches in the order 3200K→4300K→5600K→6300K.</p> <p>These can also be applied from a menu (apply with Electrical CC<A><C><D>).</p> <p>Note</p> <p>This function is not available when Maintenance >White Filter >ND Filter C.Temp in the setup menu is set to On. If you set ND Filter C.Temp to On after assigning the function, the assignable switch ceases to function.</p>	Setting retained
CC5600K	Apply a 5600K electrical CC filter to white balance adjustment values.	Setting retained
Clip Continuous Rec	Turn the Clip Continuous Rec mode on or off.	Setting not retained
Digital Extender	Turn the screen magnification function on or off when the optional CBK-HD02 SDI/COMPOSITE Input and 50 Pin Interface is installed.	Setting not retained

Functions That Can Be Assigned to the RET Button on the Lens

Assignable switch setting	Function	State when camcorder is next powered on
Off	No assignment	—
Lens RET	Display return video signals when the optional CBK-HD02 is installed and a camera extension unit is connected. When a camera extension unit is not connected, function as follows. During recording or playback: Write a shot mark. In the other states: Conduct a recording review (if playback is allowed).	—
Return Video	Display return video signals when the optional CBK-HD02 is installed and a camera extension unit is connected.	—
Rec Review	Execute recording review.	—
Shot Mark1	Write Shot Mark1.	—
Shot Mark2	Write Shot Mark2.	—
Clip Flag OK	Add/Clear an OK mark to/from the clip being recorded or played.	Setting not retained
Clip Flag NG	Add/Clear an NG mark to/from the clip being recorded or played.	Setting not retained
Clip Flag Keep	Add/Clear a KP mark to/from the clip being recorded or played.	Setting not retained
OK Mark	Add or delete an OK mark.	—
Focus Mag	Turn the focus magnification function on or off.	Setting not retained

Saving and Loading Settings

You can save setup menu settings in the camcorder's internal memory and on SxS memory cards or USB flash drives (in UDF mode). This allows you to quickly recall an appropriate set of menu settings for the current situation.

Setting data is saved in the following categories.

User files: User files save customized USER

menu setting items and setting data. You can save up to 64 user files on SxS memory cards and on USB flash drives (in UDF mode).

You can set up the USER menu to a customized state by reading one of these files into the unit's memory.

ALL files: ALL files save the setting data of all menus. You can save up to 64 ALL files on an SxS memory card or a USB flash drive (in UDF mode).

Note

Device specific data (shading, output levels, and other data that requires adjustment for the specific device) is not saved.

Scene files: Scene file save adjustments to PAINT menu items for the purpose of shooting a particular scene. You can save up to five scene files in the camcorder's internal memory and up to 64 scene files on an SxS memory card or a USB flash drive (in UDF mode).

Reference files: Reference files save the reference values that are set when you execute FILE >Scene > Standard in the setup menu. You can save one reference file in the camcorder's internal memory and one on an SxS memory card or a USB flash drive (in UDF mode).

Lens files: Lens files save the setting data used to compensate for lens characteristics, such as flare, white shading, white balance and center markers. You can save up to 32 lens

files in the camcorder's internal memory and up to 64 lens files on an SxS memory card or a USB flash drive (in UDF mode).

The first settings stored in a file are called "preset" values.

Even after loading files to set up the camcorder, and overwriting original files with new settings, you can still recover preset values and reset files to their initial states (*see page 162*).

Saving Setting Data

This section explains how to save setting data in an ALL file.

Before starting, insert a writable SxS memory card into a memory card slot.

See "Basic Setup Menu Operations" (page 109) for information about menu operations.

1 Select FILE >All in the setup menu.

To assign a name to the data before saving it

Assign a name before proceeding to step 2.

For details, see "To assign names to files" (page 161).

2 Select All Save(SxS) >Execute.

An ALL file list box appears.

File numbers where "No File" is displayed are empty file numbers. File numbers with a file name or a date and time are the number of files that already contain data.

3 Turn the MENU knob to select the desired file number.

4 Press the MENU knob.

A confirmation message appears.

5 To execute the save, select [Execute], and then press the MENU knob. To cancel the save, select [Cancel], and then press the MENU knob.

If you choose to execute the save, the ACCESS lamp lights (in blue on the right-

side panel and in orange in the card slot section). A completion message appears and the ACCESS lamp goes out when the data has been saved.

If an error message appears

One of the following error messages may appear during execution of the save, or as soon as you select [Execute]. In this case, the file is not saved to the SxS memory card.

Error message	Problem	What to do
NG:Cannot Save	No recordable media is inserted.	Insert recordable media.
NG:Media Full	The media is full.	Use media with free capacity remaining.

When using a USB flash drive (in UDF mode)

Connect a formatted USB flash drive (*see page 73*) to the external device connector. Select All Save(USB) >Execute in step 2.

To assign names to files

Assigning a name before you save data in an ALL file can make it easier to distinguish your files. The following characters can be used in file names.

Alphanumeric characters (a–z, A–Z, 0–9) and special characters (! # \$ % & ' () * + , - . / : ; < = > ? @ [\] ~)

- 1 Select FILE >All >File ID in the setup menu.**
- 2 Turn the MENU knob to select a character, and then press the MENU knob.**
- 3 Repeat step 3.**
- 4 When you have finished entering characters, press the MENU knob to move the cursor to “SET”, and then press the MENU knob.**

The specified name is displayed. When you save the file (*see page 160*), the data will be saved under this name.

Loading Setting Data

Note

When you load a file from an SxS memory card or a USB flash drive (in UDF mode), the data saved in the camcorder’s internal memory is overwritten.

See “Basic Setup Menu Operations” (*page 109*) for information about menu operations.

- 1 Select FILE >All in the setup menu.**
- 2 Select All Load(SxS) >Execute.**
A list box of ALL files appears. File numbers where “No File” is displayed are empty file numbers. File numbers with a file name or a date and time are the number of files that already contain data.
- 3 Turn the MENU knob to select the desired file number.**
- 4 Press the MENU knob.**
A confirmation message appears.
- 5 To execute the load, select [Execute], and then press the MENU knob. To cancel the load, select [Cancel], and then press the MENU knob.**
If you choose to execute the load, the ACCESS lamp lights (in blue on the right-side panel and in orange in the card slot section). The ACCESS lamp goes out and a completion message appears when the data has been loaded.

If an error message appears

One of the following error messages may appear during execution of the load, or as soon as you select [Execute]. In this case, the file is not loaded from the SxS memory card.

Error message	Problem	What to do
NG:No Data	<ul style="list-style-type: none"> There is no readable media The specified file does not exist on the media 	Insert the media that contains the file you want.

When using a USB flash drive (in UDF mode)

Connect a formatted USB flash drive (*see page 73*) to the external device connector. Select All Load(USB) >Execute in step 2.

Resetting a File after Changing Its Contents

See “Basic Setup Menu Operations” (page 109) for information about menu operations.

- 1 Select FILE >All in the setup menu.**
- 2 Select [All Preset], and then press the MENU knob.**
- 3 To execute the reset, select [Execute], and then press the MENU knob. To cancel the reset, select [Cancel], and then press the MENU knob.**

If you choose to execute the reset, all settings in the ALL file are reset to preset values.

Saving and Loading Scene Files

Scene files allow you to save the following types of data.

- Values set in the PAINT menu
- Shutter speeds set in standard mode or ECS mode
- White balance data

The data that is saved and loaded depends on the setting of FILE >Reference >Scene White Data in the setup menu.

Saving Scene Files

To save a scene file to an SxS memory card, insert the card into a memory card slot and then proceed as follows.

See “Basic Setup Menu Operations” (page 109) for information about menu operations.

- 1 Select FILE >Scene in the setup menu.**

To assign a name to the data before saving it

Assign a name before proceeding to step 2.

For details, see “To assign names to files” (page 161).

- 2 Select Scene Store Mem >Excute (if you want to save the data in the camcorder’s internal memory), or select Scene Store SxS >Execute (if you want to save the data on an SxS memory card).**
- 3 Press the MENU knob.**
A list box of scene files appears.
File numbers where “No File” is displayed are empty file numbers
- 4 Select the file number under which you want to save the data, and then press the MENU knob.**
A confirmation message appears.

- 5 To execute the save, select [Execute], and then press the MENU knob. To cancel the save, select [Cancel], and then press the MENU knob.**

If you selected Scene Store SxS >Execute in step 2, the ACCESS lamp lights (in blue on the right-side panel and in orange in the card slot section) when you execute the save.

When the data has been saved, a completion message appears and the ACCESS lamp goes out.

When using a USB flash drive (in UDF mode)

Connect a formatted USB flash drive (*see page 73*) to the external device connector.

Select Scene Store USB >Execute in step 2.

When the data has been loaded, a completion message appears and the ACCESS lamp goes out.

When using a USB flash drive (in UDF mode)

Connect a formatted USB flash drive (*see page 73*) to the external device connector.

Select Scene Recall USB >Execute in step 2.

Loading Scene Files

To load a scene file from an SxS memory card, insert the SxS memory card into a memory card slot, and then proceed as follows.

See “Basic Setup Menu Operations” (page 109) for information about menu operations.

- 1 Select FILE >Scene in the setup menu.**
- 2 Select Scene Recall Mem >Execute (if you want to load the file from the camcorder’s internal memory), and select Scene Recall SxS >Execute (if you want to load the file from an SxS memory card).**
- 3 Press the MENU knob.**
A list box of scene files appears. File numbers where “No File” is displayed are empty file numbers.
- 4 Select the desired file number, and then press the MENU knob.**
A confirmation message appears.
- 5 To execute the load, select [Execute], and then press the MENU knob. To cancel the load, select [Cancel], and then press the MENU knob.**
If you selected Scene Recall SxS >Execute in step 2, the ACCESS lamp lights (in blue on the right-side panel and in orange in the card slot section) when you execute the load.

Saving and Loading Lens Files

Setting Lens File Data

Use FILE >Lens (*see page 153*) in the setup menu to set the data in lens files.

You can set the following data and save it as a lens file.

Setting data	Sub-items
V modulation shading compensation values	M V Modulation
Center marker position	Lens Center H Lens Center V
Flare level	Lens R Flare Lens G Flare Lens B Flare
White balance compensation value	Lens W-R Offset Lens W-B Offset
White shading compensation value	L R/G/B H Saw L R/G/B H Para L R/G/B V Saw L R/G/B V Para

See “Basic Setup Menu Operations” (*page 109*) for information about menu operations.

Saving Lens Files

To save a lens file to an SxS memory card, insert the card into a memory card slot and then proceed as follows.

See “Basic Setup Menu Operations” (*page 109*) for information about menu operations.

1 Select FILE >Lens in the setup menu.

To assign a name to the data before saving it

Assign a name before proceeding to step 2.

For details, see “To assign names to files” (*page 161*).

2 Select Lens Store Mem >Execute (if you want to save the data in the camcorder’s internal memory), and select Lens Store

SxS >Execute (if you want to save the data on an SxS memory card).

3 Press the MENU knob.

If you select [Execute], a list box of lens file number appears. File numbers where “No File” is displayed are empty file numbers.

4 Select the file number under which you want to save the data, and then press the MENU knob.

A confirmation message appears.

5 To execute the save, select [Execute], and then press the MENU knob. To cancel the save, select [Cancel], and then press the MENU knob.

If you selected Lens Store SxS >Execute in step 2, the ACCESS lamp lights (in blue on the right-side panel and in orange in the card slot section) when you execute the save.

When the data has been saved, a completion message appears and the ACCESS lamp goes out.

When using a USB flash drive (in UDF mode)

Connect a formatted USB flash drive (*see page 73*) to the external device connector. Select Lens Store USB >Execute in step 2.

Loading Lens Files

To load a lens file from an SxS memory card, insert the SxS memory card into a memory card slot, and then proceed as follows.

See “Basic Setup Menu Operations” (*page 109*) for information about menu operations.

1 Select FILE >Lens in the setup menu.

2 Select Lens Recall Mem >Execute (if you want to load the file from the camcorder’s internal memory), and select Lens Recall SxS >Execute (if you want to load the file from an SxS memory card).

3 Press the MENU knob.

If you select [Execute], a list box of lens files appears. File numbers where “No File” is displayed are empty file numbers.

- 4 Select the desired file number, and then press the MENU knob.**

A confirmation message appears.

- 5 To execute the load, select [Execute], and then press the MENU knob. To cancel the load, select [Cancel], and then press the MENU knob.**

If you selected Lens Recall SxS >Execute in step 2, the ACCESS lamp lights (in blue on the right-side panel and in orange in the card slot section) when you execute the load.

When the specified lens file has been loaded, a completion message appears and the ACCESS lamp goes out.

When using a USB flash drive (in UDF mode)

Connect a formatted USB flash drive (see page 73) to the external device connector. Select Lens Recall USB >Execute in step 2.

Loading Lens Files Automatically

When you are using a lens that support serial communication, you can set up the camcorder by automatically loading the lens file that corresponds to the lens settings (Lens Auto Recall function).

To use the Lens Auto Recall function, set FILE >Lens >Lens Auto Recall in the setup menu to one of the following.

On: Load the lens file that corresponds to the model name.

Off: Do not use the Lens Auto Recall function.

Serial Number: Load the lens file that corresponds to the model name and serial number (when the lens supports communication of the serial number).

If the lens does not support communication of the serial number, both settings load the lens file that corresponds to the model name.

Saving and Loading User Files

You can save the customized USER menu configuration and settings along with white balance data as user files.

Saving User Files

To save a user file to an SxS memory card, insert the card into a memory card slot and then proceed as follows.

See “Basic Setup Menu Operations” (page 109) for information about menu operations.

- 1 Select FILE >User in the setup menu.**
To assign a name to the data before saving it
 Assign a name before proceeding to step 2.
For details, see “To assign names to files” (page 161).
- 2 Select User Save SxS >Execute.**
 A user file list box appears.
 File numbers where “No File” is displayed are empty file numbers. File numbers with a file name or a date and time are the number of files that already contain data.
- 3 Turn the MENU knob to select the desired file number.**
- 4 Press the MENU knob.**
 A confirmation message appears.
- 5 To execute the save, select [Execute], and then press the MENU knob. To cancel the save, select [Cancel], and then press the MENU knob.**
 If you choose to execute the save, the ACCESS lamp lights (in blue on the right-side panel and in orange in the card slot section). A completion message appears and the ACCESS lamp goes out when the data has been saved.

Saving the USER menu as a user file in which all menu settings are reset to the preset values

Select Store User Preset >Execute in step 2.

When using a USB flash drive (in UDF mode)

Connect a formatted USB flash drive (*see page 73*) to the external device connector.

Select User Save USB >Execute in step 2.

The ACCESS lamp does not light while the save is being executed in step 5.

Loading Setting Data**Note**

When you load a file from an SxS memory card or a USB flash drive (in UDF mode), the data saved in the camcorder's internal memory is overwritten.

Depending on the settings of Use Load Customize Data and User Load White under FILE >User in the setup menu

When Load Customize Data is set to [Off]:

Only USER menu settings are loaded.

When Load Customize Data is set to [On]:

USER menu configuration and settings are loaded.

When User Load White is set to [Off]: White balance data is not loaded.

When User Load White is set to [On]: White balance data is loaded.

See "Basic Setup Menu Operations" (page 109) for information about menu operations.

- 1 Select FILE >User in the setup menu.**
- 2 Select User Load SxS >Execute.**
A list box of user files appears.
File numbers where "No File" is displayed are empty file numbers. File numbers with a file name or a date and time are the number of files that already contain data.
- 3 Turn the MENU knob to select the desired file number.**
- 4 Press the MENU knob.**
A confirmation message appears.
- 5 To execute the load, select [Execute], and then press the MENU knob. To**

cancel the load, select [Cancel], and then press the MENU knob.

If you choose to execute the load, the ACCESS lamp lights (in blue on the right-side panel and in orange in the card slot section). The ACCESS lamp goes out and a completion message appears when the data has been loaded.

When using a USB flash drive (in UDF mode)

Connect a formatted USB flash drive (*see page 73*) to the external device connector.

Select User Load USB >Execute in step 2.

The ACCESS lamp does not light while the save is being executed in step 5.

You can connect an RM-B150/B750 Remote Control Unit and operate this camcorder. For connection and operation of the RM-B150/B750, refer to the Supplement supplied in the CD-ROM (labeled “Manuals for Solid-State Memory Camcorder”).

Connecting External Monitors

Select the output signal and use an appropriate cable for the monitor to be connected.

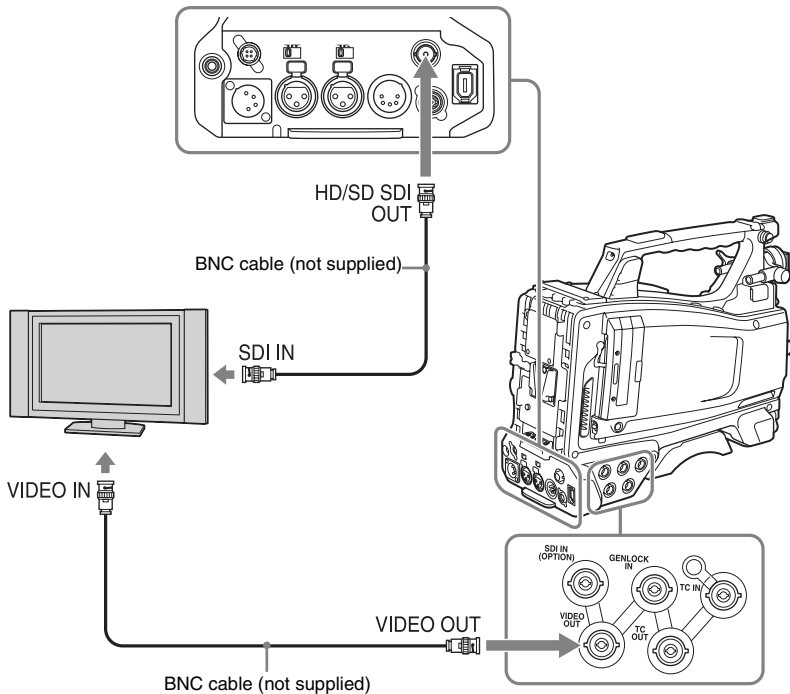

Regardless of whether the signal is HD or SD, the same status information and menus can be displayed on the external monitor as those on the viewfinder screen.

Note

SD signals down-converted for output have the following restrictions:

Images of 50P/50i/25P are output as PAL signals, those of 59.94P/59.94i/29.97P are output as NTSC signals, and those of 23.98P are output as 2-3 pulled-down NTSC signals.

HD/SD SDI OUT connector (BNC)

The HD/SD SDI OUT connector can be used to connect a device that supports SDI. The device type can be a monitor, switcher, or VTR or other recording device.

The output from this connector can be turned on and off with OPERATION >Input/Output >SDI Output in the setup menu (*see page 114*).

For connection, use a BNC cable (not supplied).

VIDEO OUT connector

The VIDEO OUT connector can be used to connect a device that supports analog composite signal. The device type can be a monitor or VTR or other recording device.

The output signal varies as shown in the following table depending on the setting of OPERATION >Output&i.LINK in the setup menu.

Setting	Output signal
HD&HDV (in FAT mode) HD (in UDF mode)	HD-Y analog signal which has the same video format with the signal output from the HD/SD SDI OUT connector.
SD&HDV or SD&DV (in FAT mode) SD (in UDF mode)	Composite signal which has the same video format with the signal output from the HD/SD SDI OUT connector. When OPERATION >Format >HD/SD in the setup menu is [SD], the output composite signal is the same as the NTSC or PAL encoded signal that is output from the HD/SD SDI OUT connector ^{a)} .

a) Use OPERATION >Format >Country (*see page 113*) in the setup menu to switch between NTSC and PAL.

To input the VIDEO OUT connector output signal to an external analog composite device, it may be necessary to change the input signal setting of that external device to be matched with the analog composite signal setting for the VIDEO OUT connector.

To input camcorder output audio to an external device such as a monitor or VTR or other recording device, connect the audio output of the AUDIO OUT connector to the audio input of that external device.

For connection, use a BNC cable (not supplied).

i.LINK (HDV/DV) connector

In FAT mode, i.LINK (HDV/DV) connector supports HDV and DV input/output. However, DV streams cannot be recorded on this camcorder.

This connector can be used to connect a device that supports i.LINK (HDV). The device type can be a monitor, read/write device such as VTR or HDD, or computer.

To input/output HDV signals

HDV input/output is supported when the video format is an HDV compatible format (SP 1440/59.94i, SP 1440/50i, or SP 1440/23.98P), Input/Output >Output&i.LINK in the OPERATION menu is set to [HD&HDV] or [SD&HDV], and Input/Output >i.LINK I/O is set to [Enable]. When the video format is SP 1440/23.98P, a 59.94i HDV signal subjected to 2-3 pulldown processing is output.

To input/output DV signals

DV input/output is supported under either of the following conditions.

- Input/Output >i.LINK I/O in the OPERATION menu is set to [Enable] on SD mode.
- On HD mode, the video format is other than DV incompatible formats (HQ 1920/23.98P, HQ 1440/23.98P, and HQ 1280/23.98P), Input/Output >Output&i.LINK is set to [SD&DV], and Input/Output >i.LINK I/O is set to [Enable].

Operating Clips with a Computer

The clips recorded on SxS memory cards with this camcorder can be controlled on a computer or edited using the optional nonlinear editing software.

For these purposes, the clips on an SxS memory card can be operated by directly loading the card in a computer or by connecting the camcorder or the optional SBAC-US10 SxS Memory Card USB Reader/Writer to the computer, using an USB cable as shown below.

Using the ExpressCard Slot of a Computer

If the computer is equipped with an ExpressCard/34 or ExpressCard/54 slot, you can directly insert the SxS memory card containing clips recorded with this camcorder and access to the files.

For the operating requirements for the computer, see "Using the CD-ROM" (page 14).

Note

The SxS Device Driver Software and SxS UDF driver software on the CD-ROM supplied with the camcorder must be installed on your computer. Before installation, be sure to read the enclosed SxS Device Driver Software End-User License Agreement.

For information on installation of the driver software, refer to the ReadMe on the supplied CD-ROM.

For support information for the driver software, visit the following URL:

<http://www.sony.net/SxS-Support/>

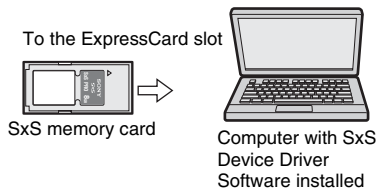

With a Windows computer

Check that a Removable Disk appears in My Computer. This indicates normal status.

With a Macintosh computer

An icon is displayed on the menu bar.

USB Connection with a Computer

Preparations

When you connect the camcorder to a computer using a USB cable (not supplied), the memory card in the slot is acknowledged as an extended drive by the computer.

When two memory cards are mounted in this camcorder, they are acknowledged as two independent extended drives by the computer.

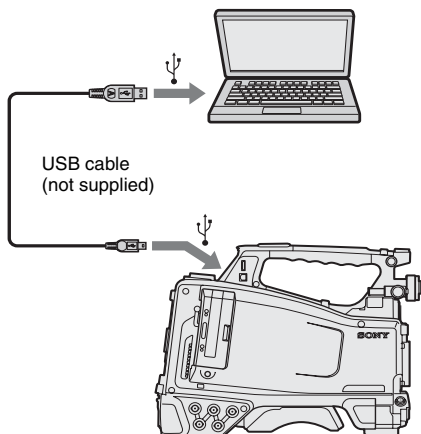

Notes

- When connecting the USB cable to the computer, be careful to check the form and direction of the USB connector.
- The camcorder does not work on the bus power from the computer.

To start USB connection

Note

When a computer is connected to the PC connector of the camcorder and at the same time an optional PHU-120R Professional Harddisk Unit (powered from a battery) is connected to the computer, battery exhaustion on the PHU-120R (indicated by a Battery End warning) disables the following.

- To guard the PHU-120R against access from the computer
- To disconnect the PHU-120R's cable from the memory card slot or plug again the cable into the slot

- To turn on the tally indicator on the viewfinder screen to warn the operator

When you connect a computer to the PC connector with a USB cable (not supplied), the message “Connect USB Now?” is displayed to prompt you to confirm that you wish to enable the USB connection.

If you select “Cancel” or push the MENU CANCEL/PRST/ESCAPE down to the ESCAPE side or if you disconnect the USB cable, the message “Connect USB Now?” disappears.



If you select “Execute” and press the MENU knob, the USB connection is enabled and this camcorder is recognized as an extension drive. You can carry out the same operations by using the arrow buttons (↑, ↓, ←, ⇒) (see page 22).



If the USB connection is enabled during recording/playback operation, the operation is stopped and the message “USB Connecting” appears on the viewfinder screen.

At this time, the output signal from the VIDEO OUT connector, and HD/SD SDI OUT connector changes to a black signal.

Notes

- The camcorder cannot be operated for recording, playback, and so on while the message “USB Connecting” is displayed.
- When the computer accesses the media loaded in the camcorder, do not try to carry out the following operations.
 - Operating the camcorder (turning the power on/off, switching the operation mode, etc.)
 - Removing or loading a media from an active slot (being accessed from the computer)
 - Removing or connecting the USB cable

Disabling the USB connection

To disable the USB connection, follow the same procedure as that for removing a device from the computer.

To enable the USB connection again, first disconnect the USB cable and then reconnect it.

The message “Connect USB Now?” appears again.

Note

If you connect the camcorder to the computer using an i.LINK cable, you cannot use the computer to operate files stored in a recording media loaded in the memory card slot of this camcorder.

To remove an SxS memory card

Windows

1. Click on the icon of “Safely Remove Hardware” on the task bar of the computer.
2. Select “Safely remove SxS Memory Card - Drive(X:)” from the displayed menu.
3. Check that the Safe To Remove Hardware message appears then remove the card.

Macintosh

Drag the SxS memory card icon on the desktop to Trash.

If the SxS memory card icon is located on Finder, click on the eject icon on its side.

To use the application software

To copy clips to the local disk of a computer, the supplied application software must be used.

Install the application software on the supplied CD-ROM to your computer.

Although the data regarding recorded materials are stored over multiple files and folders, you can easily handle the clips without considering such data and directory structure by using the supplied application software.

Note

If you operate, e.g. copy the clips on the SxS memory card by using the Explorer (Windows) or Finder (Macintosh), the subsidiary data contained by the clips may not be maintained. To avoid such a problem, use the application software.

For installation and operations, refer to the User’s Guide contained in the CD-ROM.

For support information on the application software, visit on the cover page of the supplied CD-ROM.

To use a nonlinear editing system

For a nonlinear editing system, optional editing software that corresponds to the recording formats used with this camcorder is required.

Store the clips to be edited on the HDD of your computer in advance, using the supplied application software.
Some editing software may not operate properly. Be sure to confirm before use that it conforms to the recording formats used with this camcorder.

Connecting an External Device (i.LINK Connection)

FAT

You can record the same images as those recorded on the memory card in this camcorder on an external device connected to the i.LINK (HDV/DV) connector, or record the playback picture of the external device on the memory card in the camcorder.

When you connect the camcorder to a non-linear editing system that supports HDV format, you can edit the images recorded on the memory card in the camcorder.

Notes

- i.LINK connection is available only in FAT mode.
- Use the i.LINK (HDV/DV) connector only for one-to-one i.LINK connection.
- When you change a setting which affects output signals from the i.LINK (HDV/DV) connector, such as HD/SD, HD System Line, System Frequency, and Rec Format under OPERATION >Format in the setup menu or i.LINK I/O and Down Converter under OPERATION >Input/Output in the setup menu, disconnect the i.LINK cable and change the setting. Changing such a setting with the i.LINK cable connected may cause improper operation of the connected i.LINK device.
- The external signal input via the i.LINK connection that can be recorded on the camcorder is HDV streams only. You cannot record DV streams via the i.LINK connection.

Recording the Camera Picture on an External Device

The picture being shot with this camcorder is output as an HDV or DV stream via the i.LINK (HDV/DV) connector. It can be recorded on a connected HDV or DVCAM recorder in synchronization with a recording start/stop operation on this camcorder.

- 1 Perform the preparatory settings of the camcorder.**

- Set OPERATION >Input/Output >Output & i.LINK in the setup menu (see page 114) to “HD & HDV” or “SD & HDV”.

HD & HDV or SD & HDV: To output an HDV stream in HD mode when the video format is set to an HDV compatible format (SP 1440/59.94i, SP 1440/50i, or SP 1440/23.94P)

SD & DV: To output a DV stream

- Set OPERATION >Input/Output >i.LINK I/O in the setup menu to [Enable].
- Set MAINTENANCE >Trigger Mode >i.LINK Trigger Mode in the setup menu (see page 146) to [Both] or [External].

Both: To perform recording both on the memory card in this camcorder and on the external device

External: To perform recording only on the external device





2 Set the external device to recording standby status.

For operations of the external device, refer to the operation manual of that device.

3 Start recording.

The external device starts recording in synchronization.

The status of the external device is displayed in the i.LINK status indication area (see page 33) on the viewfinder screen.

Indication	Status of the external device
STBY 	In HDV recording standby
●REC 	In HDV recording
STBY 	In DV recording standby
●REC 	In DV recording

Notes

- Operation may be different depending on the type of external device.
- When you execute the operation to make a recording on the recording media loaded in the camcorder while HDV signals are output from the i.LINK (HDV/DV) connector, HDV signal output stops for about one second before the recording starts, and then it resumes.
- While you can record shot marks on the memory card during recording, they are not added to the pictures recorded on the external device.

Nonlinear Editing

You can transfer an HDV stream to a nonlinear editing system connected via the i.LINK (HDV/DV) connector.

Notes

- The i.LINK (HDV/DV) connector of this camcorder is a 6-pin connector. Check the number of pins of the i.LINK connector on your computer and use an appropriate i.LINK cable.
- In searching pictures of this camcorder on the computer, it may take some time until the display is reflected on the computer.
- If the playback clip is short or the playback starting point is near the end of the clip, the i.LINK signal may be interrupted between the clip and the next clip. When you try to capture such a signal using the nonlinear editing system, a malfunction may occur, depending on the nonlinear editing software in use.
- If you specify a search speed other than 4, 15, or 24 times normal with the nonlinear editing system, no i.LINK signal is fed out. In such a case, the picture on the LCD monitor may stay frozen.
- High-speed playback picture may not be displayed on the computer screen, depending on the nonlinear editing software in use.

Setting on this camcorder

Set OPERATION >Input/Output >i.LINK I/O in the setup menu to [Enable].

For operations of the nonlinear editing software, refer to the operation manual of the software.

Recording External Input Signals

The HDV stream input from a device connected via the i.LINK (HDV/DV) connector can be recorded on an SxS memory card in this camcorder.

The timecodes superimposed on the i.LINK input are recorded regardless of the settings of the camcorder.

Note

DV stream cannot be recorded.

1 Set the external signal to a format that can be recorded on the camcorder.

Select an HDV compatible format (SP 1440/59.94i, SP 1440/50i, or SP 1440/23.94P) for the video format.

2 Make the following settings with OPERATION >Input/Output in the setup menu (see page 114).

- Set **Output&i.LINK** to [HD&HDV] or [SD&HDV].
- Set **i.LINK I/O** to [Enable].
- Set **Source Select** to [i.LINK].

The input video is displayed on the viewfinder screen or the monitor connected to the VIDEO OUT connector.

Audio signals are output through the built-in speakers, the headphones connected to the EARPHONE connector, and the speakers of the monitor connected to the VIDEO OUT connector.

3 Start the recording.

Notes

- An error is generated in the following cases. In such a case, cancel Recording mode.
 - The video format of input signal does not match that specified on the camcorder.
 - A copy-protected stream is being fed in.
- If the input to the camcorder becomes no signal during recording, the TALLY indicators, the tally indicator on the front of the viewfinder, and the REC indication (●REC) on the viewfinder screen flash, indicating that no signal is being recorded on the SxS memory card. When an input signal is resumed, recording is restarted, incrementing the clip number on the memory card.

Configuring a Shooting and Recording System

If you install the optional CBK-HD02 on this camcorder, you can attach the XDCA-55 HD Camera Adaptor and connect the XDCU-50 HD Camera Extension Unit.

This allows you to configure a shooting and recording system consisting of multiple camcorders with camera extension units connected to a remote control unit.

For more information about the XDCA-55 and XDCU-50, refer to their respective operation manuals.

Note

When using the camcorder in this system, do not connect a video light to the camcorder.

Testing the Camcorder

Check the functions of the camcorder before setting out for a shooting session, preferably by recording and playing back video and audio signals.

Maintenance

Cleaning the Viewfinder

Use a dust blower to clean the CRT screen and mirror inside the viewfinder barrel. Clean the lens and protecting filter with a commercially available lens cleaner.

Caution

Never use organic solvents such as thinners.

Disassembling the eyepiece for cleaning (example: HDVF-20A)

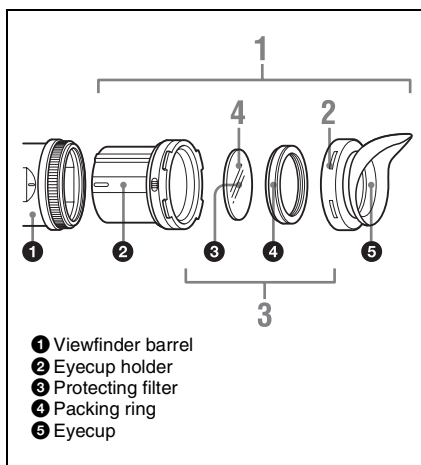

1 Detach the eyepiece from the viewfinder barrel.

For the detaching procedure, see "Detaching the Eyepiece" on page 39.

2 Remove the eyecup from the eyecup holder.

3 Remove the protecting filter, together with the packing ring, from inside the eyecup holder.

4 Detach the protecting filter from the packing ring.

Fog-proof filter

Depending on the temperature and humidity, the protecting filter may mist because of vapor or your breath. To ensure that the viewfinder is always clear, replace the protecting filter with a fog-proof filter (service part number: 1-547-341-11).

Fitting the fog-proof filter

Replace the protecting filter on the packing ring with the fog-proof filter.

Be sure to correctly assemble the fog-proof filter, the packing ring, and the eyecup so that the reassembled eyepiece is waterproof.

Note

When cleaning the fog-proof filter, wipe it very gently with a soft cloth to avoid damaging the anti-fogging coating.

Note about the Battery Terminal

The battery terminal of this unit (the connector for battery packs and AC adaptors) is a consumable part.

Power may not be supplied to the unit properly if the pins of the battery terminal are bent or deformed by shock or vibrations, or if they become corroded due to prolonged outdoor use. Periodic inspections are recommended to keep the unit working properly and to prolong its usable lifetime.

Contact a Sony service or sales representative for more information about inspections.

Operation Warnings

If a problem occurs when the camcorder is powered or is being operated, a warning is issued by various visible and audible indicators. These visible and audible indicators are:

- Error/warning message (“A” in the “Layout of the table of warning messages” below)
- WARNING indicator (“B”), warning sound from the speaker and earphones (“C”), tally/REC indication (“D”), and battery remaining indicator (“E”).

A warning message, and the REC indication appear on the viewfinder screen.

The volume of the warning sound can be adjusted with the ALARM knob. Set the ALARM knob to the minimum position to suppress the sound.

Layout of the table of warning messages

A	WARNING indicator	Warning sound	Tally/REC	Battery remaining
	B	C	D	E
	Problem	Operation in the recorder module	Action to take	

- The operation of the WARNING indicator, the tally/REC indication, and the battery indicator is represented by graphic symbols as follows.

 : Continuous

 : 1 flash/s



 : 4 flashes/s

- The warning sounds are represented by graphic symbols as follows.

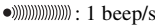











•  : Continuous beep







•  : 1 beep/s

Error Indication

E*****	WARNING indicator	Warning sound	Tally/REC	Battery remaining
	—	• 		—
	Problem	Operation in the recorder module	Action to take	
	Error (The camcorder is abnormal.)	Recording stops.	Turn off the power and confirm whether an error occurs on the connected devices, the cables, and the media or not. (If power cannot be turned off by setting the POWER switch to OFF, remove the battery pack or the AC power source.) If the problem continues after the camcorder is restarted, contact your Sony service representative.	





Warning Indication

Media Near Full	WARNING indicator	Warning sound	Tally/REC	Battery remaining
		●))))))))))		—
	Problem	Operation in the recorder module	Action to take	
	Free space on the SxS memory card has become insufficient.	Recording continues.	Replace it with another at the earliest opportunity.	
Media Full	WARNING indicator	Warning sound	Tally/REC	Battery remaining
		●)))))))))))))		—
	Problem	Operation in the recorder module	Action to take	
	No space is left on the SxS memory card. Recording, clip copying and clip division cannot be performed.	Recording stops.	Replace it with another.	
Battery Near End	WARNING indicator	Warning sound	Tally/REC	Battery remaining
		●))))))))))		
	Problem	Operation in the recorder module	Action to take	
	The battery power will be exhausted soon.	Recording continues.	Charge the battery pack at the earliest opportunity.	
Battery End	WARNING indicator	Warning sound	Tally/REC	Battery remaining
		●)))))))))))))		
	Problem	Operation in the recorder module	Action to take	
	The battery pack is exhausted. Recording cannot be performed.	Recording stops.	Connect a power source via the DC IN connector or stop operation to charge the battery pack.	
Temperature High	WARNING indicator	Warning sound	Tally/REC	Battery remaining
		●))))))))))		—
	Problem	Operation in the recorder module	Action to take	
	The internal temperature has risen above a safe operation limit.	Recording continues.	Suspend operation, turn off the power, and wait until the temperature falls.	

Voltage Low	WARNING indicator	Warning sound	Tally/REC	Battery remaining
		●)))))))))		
	Problem	Operation in the recorder module	Action to take	
	The DC IN voltage has become low (stage 1).	Recording continues.	Check the power supply.	
Insufficient Voltage	WARNING indicator	Warning sound	Tally/REC	Battery remaining
		●)))))))))		
	Problem	Operation in the recorder module	Action to take	
	The DC IN voltage is too low (stage 2). Recording cannot be performed.	Recording stops.	Connect other power source.	
Battery Error Please Change Battery.	WARNING indicator	Warning sound	Tally/REC	Battery remaining
	—	—	—	—
	Problem	Operation in the recorder module	Action to take	
	An error was detected with the battery pack.	Recording stops.	Replace the battery pack with a normal one.	
Backup Battery End Please Change.	WARNING indicator	Warning sound	Tally/REC	Battery remaining
	—	—	—	—
	Problem	Operation in the recorder module	Action to take	
	The remaining power of the backup battery is insufficient.	Recording continues.	Refer to a Sony service representative to replace the battery with a new one.	
Unknown Media(A) ¹⁾ Please Change.	WARNING indicator	Warning sound	Tally/REC	Battery remaining
	—	—	—	—
	Problem	Operation in the recorder module	Action to take	
	A partitioned memory card or one that contains recorded clips exceeding the number permitted with this camcorder is loaded.	Recording continues.	This card cannot be used with this camcorder. Remove it and load a compatible card.	

Reached Clip Number Limit Cannot Record to Media(A) ¹⁾	WARNING indicator	Warning sound	Tally/REC	Battery remaining
	—	—	—	—
	Problem	Operation in the recorder module	Action to take	
The maximum number of clips for a single memory card is reached. No more clip can be recorded on the card.	Recording stops.	Replace it with another card.		
Media Error Media(A) ¹⁾ Needs to be Restored	WARNING indicator	Warning sound	Tally/REC	Battery remaining
	—	—	—	—
	Problem	Operation in the recorder module	Action to take	
An error occurred with the memory card. The card requires restoration.	Recording stops.	Remove the card, load it again, and restore it.		
Media Error Cannot Record to Media(A) ¹⁾	WARNING indicator	Warning sound	Tally/REC	Battery remaining
	—	—	—	—
	Problem	Operation in the recorder module	Action to take	
Recording cannot be done, as the memory card is defective.	Recording stops.	As playback may be possible, it is recommended to replace it with another card after copying the clips, as required.		
Media Error Cannot Use Media(A) ¹⁾	WARNING indicator	Warning sound	Tally/REC	Battery remaining
	—	—	—	—
	Problem	Operation in the recorder module	Action to take	
Neither recording nor playback can be done, as the memory card is defective.	Recording stops.	It cannot be operated with this camcorder. Replace it with another card.		
Cannot Use Media(A) ¹⁾ Unsupported File System	WARNING indicator	Warning sound	Tally/REC	Battery remaining
	—	—	—	—
	Problem	Operation in the recorder module	Action to take	
A card of a different file system was inserted.	Recording stops.	It cannot be used with this camcorder. Replace it with another card.		

Video Format Mismatch	WARNING indicator	Warning sound	Tally/REC	Battery remaining
	—	—	—	—
	Problem	Operation in the recorder module	Action to take	
	The external signal input via the i.LINK connection cannot be recorded, as the Video Format setting is different from the signal format of the external input signal.	Recording stops.	Change settings of OPERATION >Format in the setup menu to match it to that of the external signal.	
Copy Protected Input Cannot Record	WARNING indicator	Warning sound	Tally/REC	Battery remaining
	—	—	—	—
	Problem	Operation in the recorder module	Action to take	
	The external signal input via the i.LINK connection cannot be recorded, as the stream is copy-protected.	Recording stops.	Check the input signal.	
DV/CAM Input Signal! Cannot Record	WARNING indicator	Warning sound	Tally/REC	Battery remaining
	—	—	—	—
	Problem	Operation in the recorder module	Action to take	
	The external signal input via the i.LINK connection cannot be recorded, as it is a DV stream.	Recording stops.	—	
Media Error Playback Halted	WARNING indicator	Warning sound	Tally/REC	Battery remaining
	—	—	—	—
	Problem	Operation in the recorder module	Action to take	
	An error occurred in reading data from the memory card, and playback cannot be continued.	Recording stops.	If this frequently occurs, change the memory card after copying the clips, as required.	
Media(A) ¹⁾ Error	WARNING indicator	Warning sound	Tally/REC	Battery remaining
	—	—	—	—
	Problem	Operation in the recorder module	Action to take	
	Recording cannot be done, as an error occurred with the memory card.	Recording stops.	If this frequently occurs, change the memory card.	

HDD A ² Battery Near End	WARNING indicator	Warning sound	Tally/REC	Battery remaining
		●)))))))))		—
	Problem	Operation in the recorder module	Action to take	
	The battery power of the connected HDD will be exhausted soon.	Recording continues.	Change the battery at the earliest opportunity.	
HDD A ² Battery End	WARNING indicator	Warning sound	Tally/REC	Battery remaining
		●)))))))))		—
	Problem	Operation in the recorder module	Action to take	
	The battery of the connected HDD is exhausted. Recording cannot be performed.	Recording stops.	Stop operation to change the battery.	
Not Enough Capacity Change Media(A) ¹	WARNING indicator	Warning sound	Tally/REC	Battery remaining
	—	—	—	—
	Problem	Operation in the recorder module	Action to take	
	There is not enough capacity for copying.	Recording continues (disallowing copy).	Replace the card in slot A with another one.	
Reached Duplication Limit Change Media(A) ¹	WARNING indicator	Warning sound	Tally/REC	Battery remaining
	—	—	—	—
	Problem	Operation in the recorder module	Action to take	
	The card has already ten clips having the same name as that you tried to duplicate.	Recording continues (disallowing copy).	Replace the card in slot A with another one.	
Not Enough Capacity Cannot Divide	WARNING indicator	Warning sound	Tally/REC	Battery remaining
	—	—	—	—
	Problem	Operation in the recorder module	Action to take	
	There is not enough capacity for dividing a clip.	Recording continues (disallowing divide).	—	
Will Switch Slots Soon	WARNING indicator	Warning sound	Tally/REC	Battery remaining
	—	—	—	—
	Problem	Operation in the recorder module	Action to take	
	Will switch to other slot soon.	Recording continues.	Make sure that a memory card is loaded in the other slot.	

No Clip	WARNING indicator	Warning sound	Tally/REC	Battery remaining
	—	—	—	—
	Problem	Operation in the recorder module	Action to take	
	There is no clip to be displayed.	Recording continues.	—	
No OK Clip	WARNING indicator	Warning sound	Tally/REC	Battery remaining
	—	—	—	—
	Problem	Operation in the recorder module	Action to take	
	There is no clip with the OK mark.	Recording continues.	—	
Same File Already Exists Change Media(A) ¹⁾	WARNING indicator	Warning sound	Tally/REC	Battery remaining
	—	—	—	—
	Problem	Operation in the recorder module	Action to take	
	The card has already clips having the same name as that you tried to duplicate.	Recording continues (disallowing copy).	Replace the card in slot A with another one.	
Media Reached Rewriting Limit Change Media(A) ¹⁾	WARNING indicator	Warning sound	Tally/REC	Battery remaining
	—	—	—	—
	Problem	Operation in the recorder module	Action to take	
	The memory card comes to the end of its service life.	Recording stops.	Make a backup copy and replace the card with another one as soon as possible. Recording/playback may not be performed properly if you continue to use the card. For details, refer to the Operating Instructions of the memory card.	
Unsupported Clip Included Cannot Use Media(A) ¹⁾	WARNING indicator	Warning sound	Tally/REC	Battery remaining
	—	—	—	—
	Problem	Operation in the recorder module	Action to take	
	The inserted memory card contains clips recorded in a format that is not supported by this camcorder.	—	The card in slot A cannot be used with this camcorder.	

Fan Stopped 1)	WARNING indicator	Warning sound	Tally/REC	Battery remaining
	—	—	—	—
	Problem	Operation in the recorder module	Action to take	
	The fan does not rotate when started.	—	Avoid use under high temperature conditions. Power the camcorder off and contact a Sony service representative.	
Media was Ejected Just Now It Needs to be Restored	WARNING indicator	Warning sound	Tally/REC	Battery remaining
	—	—	—	—
	Problem	Operation in the recorder module	Action to take	
	Restoration is required because the media was removed while the camcorder was in recording standby mode of Clip Continuous Rec (<i>see page 84</i>).	Recording continues.	Insert again the media which was removed and restore it (<i>see page 72</i>).	
USB(Host)Over Current Remove USB Device	WARNING indicator	Warning sound	Tally/REC	Battery remaining
	—	—	—	—
	Problem	Operation in the recorder module	Action to take	
	Power to the external device connector was removed because overcurrent was detected on the connector. (Other operations are not affected.)	Recording continues.	Power the camcorder off and remove the Wi-Fi adapter or USB flash drive that is connected to the external device connector.	

- 1) (B) for the card in slot B
- 2) B for a HDD connected to slot B

Appendix

Important Notes on Operation

Use and storage

Do not subject the camcorder to severe shocks

- The internal mechanism may be damaged or the body warped.
- If an accessory mounted on the accessory shoe is subjected to severe shock, the accessory shoe may be damaged. In such a case, stop using it and contact your dealer or a Sony service representative.

Do not cover the camcorder while operating

Putting a cloth, for example, over the camcorder can cause excessive internal heat build-up.

After use

Always turn off the POWER switch.

Before storing the camcorder for a long period

Remove the battery pack.

Shipping

- Remove the media before transporting the camcorder.
- If sending the camcorder by truck, ship, air or other transportation service, pack it in the shipping carton of the camcorder.

Care of the camcorder

Remove dust and dirt from the surfaces of the lenses or optical filters using a blower.

If the body of the camcorder is dirty, clean it with a soft, dry cloth. In extreme cases, use a cloth steeped in a little neutral detergent, then wipe dry. Do not use organic solvents such as alcohol or thinners, as these may cause discoloration or other damage to the finish of the camcorder.

In the event of operating problems

If you should experience problems with the camcorder, contact a Sony service representative.

Use and storage locations

Store in a level, ventilated place. Avoid using or storing the camcorder in the following places.

- In excessive heat or cold (operating temperature range: -5°C to $+40^{\circ}\text{C}$ (23°F to 104°F))
- Remember that in summer in warm climates the temperature inside a car with the windows closed can easily exceed 50°C (122°F).
- In damp or dusty locations
- Locations where the camcorder may be exposed to rain
- Locations subject to violent vibration
- Near strong magnetic fields
- Close to radio or TV transmitters producing strong electromagnetic fields.
- In direct sunlight or close to heaters for extended periods

To prevent electromagnetic interference from portable communications devices

The use of portable telephones and other communications devices near this camcorder can result in malfunctions and interference with audio and video signals.

It is recommended that the portable communications devices near this camcorder be powered off.

Fitting the zoom lens

It is important to fit the lens correctly, as otherwise damage may result. *Be sure to refer to the section "Mounting and Adjusting the Lens" (page 42).*

Viewfinder

Do not leave the camcorder with the eyepiece pointing directly at the sun.

The eyepiece lens can concentrate the sun's rays and melt the interior of the viewfinder.

About the LCD panels

The LCD panel fitted to this camcorder is manufactured with high precision technology, giving a functioning pixel ratio of at least 99.99%. Thus a very small proportion of pixels maybe

“stuck”, either always off (black), always on (red, green, or blue), or flashing. In addition, over a long period of use, because of the physical characteristics of the liquid crystal display, such “stuck” pixels may appear spontaneously. These problems are not a malfunction. Note that any such problems have no effect on recorded data.

Phenomena specific to CCD image sensors

The following phenomena that may appear in images are specific to CCD (Charge Coupled Device) image sensors. They do not indicate malfunctions.

White flecks

Although the CCD image sensors are produced with high-precision technologies, fine white flecks may be generated on the screen in rare cases, caused by cosmic rays, etc.

This is related to the principle of CCD image sensors and is not a malfunction.

The white flecks especially tend to be seen in the following cases:

- When operating at a high environmental temperature
- When you have raised the master gain (sensitivity)

In SLS mode, white flecks are more prominent when you set the shutter speed (number of frames) to higher values.

The problem may be alleviated by executing the APR (automatic pixel noise reduction) function with MAINTENANCE >APR in the setup menu (see page 146). Pixel noise is reduced to some extent by automatic black balance adjustment (see page 54), but the detection capabilities of that function are limited. For the most effective correction, execute the APR function.

Vertical smear

When an extremely bright object, such as a strong spotlight or flashlight, is being shot, vertical tails may be produced on the screen, or the image may be distorted.

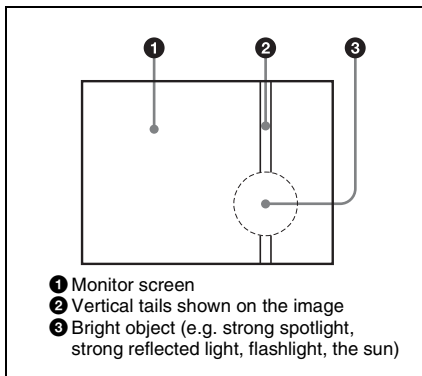

Aliasing

When fine patterns, stripes, or lines are shot, they may appear jagged or flicker.

Fragmentation

If pictures cannot be recorded/reproduced properly, try formatting the recording medium. While repeating picture recording/playback with a certain recording medium for an extended period, files in the medium may be fragmented, disabling proper recording/storage. In such a case, make a backup of clips in the medium then perform formatting of the medium using OPERATION >Format Media (see page 113) in the setup menu.

Exchanging the Battery of the Internal Clock

The camcorder's internal clock is powered by a lithium battery. If the message "BackUp Battery End" appears in the viewfinder, this battery must be exchanged. Contact a Sony service representative.

Specifications

General

Power requirements

12 V DC (11 V to 17.0 V)

Power consumption

Approx. 27 W (main unit only, during recording with the LCD monitor lit)

Notes

- Do not use a video light with power consumption of over 50 W.
- When connecting a device to the DC OUT connector, use one with current consumption of 0.5 A or more.

Operating temperature

-5°C to +40°C (23°F to 104°F)

Storage temperature

-20°C to +60°C (-4°F to 140°F)

Recording/playback formats

UDF mode

- HD422
Video codec: MPEG-2 422P@HL
Video rate: 50 Mbps/CBR
Video samples: 1920 × 1080, 1280 × 720
Proxy video: MPEG-4
Audio: LPCM 4CH, 24 bits, 48 kHz
Proxy audio: A-law
- HD420
Video codec: MPEG-2 MP@HL(1440)
Video rate: 35 Mbps/VBR
Video samples: 1440 × 1080
Proxy video: MPEG-4
Audio: LPCM 4CH, 16 bits, 48 kHz
Proxy audio: A-law
- HD420
Video codec: MPEG-2 MP@HL
Video rate: 35 Mbps/VBR
Video samples: 1280 × 720
Proxy video: MPEG-4
Audio: LPCM 4CH, 16 bits, 48 kHz
Proxy audio: A-law

- **IMX**

Video codec: MPEG-2 422P@ML Intra
 Video rate: 50 Mbps
 Video samples: 720 × 486 (NTSC)/576 (PAL)
 Proxy video: MPEG-4
 Audio: LPCM 4CH, 24/16 bits, 48 kHz
 Proxy audio: A-law

- **DVCAM**

Video rate: 25 Mbps
 Video samples: 720 × 480 (NTSC)/576 (PAL)
 Proxy video: MPEG-4
 Audio: LPCM 4CH, 16 bits, 48 kHz
 Proxy audio: A-law

FAT mode

- **HD420**

Video codec: MPEG-2 MP@HL
 Video rate: 35 Mbps/VBR
 Video samples: 1920 × 1080, 1280 × 720
 Audio: LPCM 4CH, 16 bits, 48 kHz

Video codec: MPEG-2 MP@HL(1440)
 Video rate: 35 Mbps/VBR
 Video samples: 1440 × 1080
 Audio: LPCM 4CH, 16 bits, 48 kHz

Video codec: MPEG-2 MP@H14
 Video rate: 25 Mbps/CBR
 Video samples: 1440 × 1080
 Audio: LPCM 4CH, 16 bits, 48 kHz

- **DVCAM**

Video rate: 25 Mbps
 Video samples: 720 × 480 (NTSC)/576 (PAL)
 Audio: LPCM 2CH, 16 bits, 48 kHz

Recording/playback time

With one SBP-16

FAT mode HQ: About 50 minutes
 SP: About 70 minutes
 DVCAM: About 65 minutes
 UDF mode HD422 50/IMX50: About 30 minutes
 HD420 HQ: About 45 minutes
 DVCAM: About 55 minutes

With one SBP-32/SBS-32G1A

FAT mode HQ: About 100 minutes
 SP: About 140 minutes
 DVCAM: About 130 minutes
 UDF mode HD422 50/IMX50: About 60 minutes
 HD420 HQ: About 90 minutes
 DVCAM: About 110 minutes

With one SBS-64G1A

FAT mode HQ: About 200 minutes
 SP: About 280 minutes
 DVCAM: About 260 minutes
 UDF mode HD422 50/IMX50: About 120 minutes
 HD420 HQ: About 180 minutes
 DVCAM: About 220 minutes

Note

The actual recording/playback time may differ slightly from the values shown here, depending on usage conditions, memory characteristics, etc.

Continuous operation time

With the BP-GL95
 Approx. 180 min.

Mass

Main body only: 3.4 kg (7 lb 7.9 oz)

Dimensions

See page 190.

Supplied accessories

See page 189.

Camera Block

Pickup device

²/₃-type, CCD image sensor
 Effective picture elements:
 1920 (H) × 1080 (V)

Format

3-chip RGB

Optical system
F1.4 prism system
ND filters
1: Clear
2: $\frac{1}{4}$ ND
3: $\frac{1}{16}$ ND
4: $\frac{1}{64}$ ND
Sensitivity
F11 (System frequency: 59.94i)
F12 (System frequency: 50i)
(2000lx, 89.9% reflection, 3200K)
Minimum illumination
0.016 lx (F1.4, +42 dB, 16-frame accumulation)
Video S/N
54 dB (Noise Suppress Off)
59 dB (Noise Suppress On)
Horizontal resolution
1000TV lines or more
Modulation
45% or more (27.5 MHz, at screen center)
Black level
3±1% (when Black in the setup menu is set to [±0])
Gain
-6, -3, 0, 3, 6, 9, 12, 18, 24, 30, 36, 42 dB, AGC
Shutter speed
59.94i/P, 50i/P: $\frac{1}{60}$ to $\frac{1}{2000}$ sec.
29.97P: $\frac{1}{40}$ to $\frac{1}{2000}$ sec.
25P: $\frac{1}{33}$ to $\frac{1}{2000}$ sec.
23.94P: $\frac{1}{32}$ to $\frac{1}{2000}$ sec.
Slow shutter
2 to 8, 16 frames
Dynamic range
600%
460% (1080/29.97P, 1080/25P, 1080/23.98P)
Smear
-135 dB

Audio Block

Sampling frequency
48 kHz
Quantization
16 bits/24 bits
Headroom
20 dB (the factory default setting)
(20, 18, 16, 12 dB), EBU

Frequency response
20 Hz to 20 kHz (within ±3 dB)
Dynamic range
90 dB (typical)
Distortion
0.08% max. (with input level 40 dBu)
Built-in speaker
Monaural
Output: 300 mW

Display

LCD monitor

Screen size
8.8 cm diagonal (3.5-inch)
Aspect ratio
16:9
Picture elements
640 (H) × 3 × 480 (V) Sequence delta
Transmission system
Hybrid (semi-transmissive) type

Media Block

Card slots
Type: Express Card34
Number of slots: 2
Connector: Conforms to PCMCIA Express Card Standard
Writing rate
50 Mbps or more
Reading rate
50 Mbps or more

Inputs/Outputs

Input/Output connectors

Signal inputs
GENLOCK IN: BNC type
1.0 V _{p-p} , 75 Ω, unbalanced
TC IN: BNC type
0.5 V to 18 V _{p-p} , 10 kΩ
AUDIO IN CH-1/CH-2: XLR type, 3-pin, female
(With automatic detection and switching function)
MIC: -70 to -20 dBu

LINE: +4, 0, -3 dBu
MIC IN: XLR type, 5-pin, female
-70 to -20 dBu
WRR CH1/CH2
D-sub 15-pin
WRR analog: -40 dBu
WRR digital: -40 dBFS
HD/SD SDI
When an option is installed
4-channel audio

Signal outputs

VIDEO OUT: BNC type, switching between SD analog composite and HD-Y
HD/SD SDI OUT 1/2: BNC type
0.8 Vp-p, unbalanced (switching between HD and SD)
Complied to SMPTE292M/259M
4-channel audio (CH1 to CH4)
AUDIO OUT: XLR type, 5-pin, male
+4, 0, -3 dBu (balanced)
TC OUT: BNC type
1.0 Vp-p, 75 Ω
EARPHONE (stereo minijack)
8 Ω, 5 mW

Others

DC IN: XLR type, 4-pin, male
11 to 17 V DC
DC OUT: 4-pin
11 to 17 V DC, maximum rated current:
0.5 A
LENS: 12-pin
Supplying power to the lens
11 to 17 V DC, maximum rated current:
1.0 A
REMOTE: 8-pin
LIGHT: 2-pin
USB: 4-pin (type A), 4-pin (type B)
i.LINK (HDV/DV): 6-pin, complies with
IEEE1394
VF: 26-pin, rectangular, 20-pin round
For wireless receiver: D-sub 15-pin

Supplied Accessories

Shoulder strap (1)
Cold shoe kit (1 set)
Lens mount cap (1)
Flange back adjustment chart

OPERATION MANUAL

Japanese version (1)
English version (1)

CD-ROM

- Utility Software for XDCAM (application software, device driver software) (1)
- Manuals for Solid-State Memory Camcorder (PDF OPERATION MANUAL and SUPPLEMENT) (1)

Recommended Additional Equipment

Option key

SD Record and Playback Key

CBK-MD01

Hardware Upgrade Key

CBK-UPG01

Power supply and related equipment

AC Adaptor

AC-DN10/DN2B

Battery Pack

BP-L80S/L60S

Battery Charger

BC-M150/L500/L70

Lens, Viewfinder and Related Equipment

Lens

²/₃-type bayonet mount lenses only

Viewfinder

HDVF series viewfinder: HDVF-200/20A/
C35W/C950W/C730W
CBK-VF01

Viewfinder Rotation Bracket

BKW-401

Equipment for remote control

Remote Control Unit

RM-B150/B750
RCP-1000/1500/1530

SDI/COMPOSITE Input and 50 Pin Interface

CBK-HD02

HD Camera Adaptor

XDCA-55 (when an optional CBK-HD02 is installed)

HD Camera Extension Unit

XDCU-50

MPEG TS Adaptor

HDCA-702 (when an optional CBK-HD02 is installed)

Wi-Fi Adapter

CBK-WA01 (when an optional CBK-UPG01 is installed)

Media**SxS Memory Card**

SxS PRO SBP-16 (16 GB)
 SxS PRO SBP-32 (32 GB)
 SxS-1 SBS-32G1A (32 GB)
 SxS-1 SBS-64G1A (64 GB)

Professional Harddisk Unit

PHU-120R (in FAT mode)

Media Adaptor

MEAD-MS01 (for “Memory Stick PRO-HG Duo HX” series)
 MEAD-SD01 (for SDHC card)

Mobile Storage Unit

PXU-MS240

Audio equipment**Microphone**

ECM-678/674/673/680S

Microphone Holder

CAC-12

Wireless Microphone

DWR-S01D
 WRR-855S/860C/861/862

Other peripheral devices**Tripod adaptor**

VCT-14/U14

Video Light

UC-D200A (PROTECH)
 Ultralight (Anton Bauer)

Pad

CBK-SP01 Soft Type Shoulder Pad

Equipment for maintenance and easier handling**Hard Carrying Case**

LC-H300

Soft Carrying Case

LC-DS300SFT

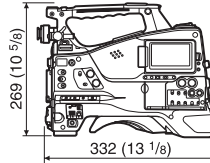
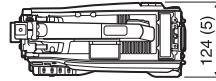
Maintenance Manual**Dimensions**

(in mm (inches))

Design and specifications are subject to change without notice.

Notes

- Always make a test recording, and verify that it was recorded successfully.
 SONY WILL NOT BE LIABLE FOR DAMAGES OF ANY KIND INCLUDING, BUT NOT LIMITED TO, COMPENSATION OR REIMBURSEMENT ON ACCOUNT OF FAILURE OF THIS UNIT OR ITS RECORDING MEDIA, EXTERNAL STORAGE SYSTEMS OR ANY OTHER MEDIA OR STORAGE SYSTEMS TO RECORD CONTENT OF ANY TYPE.
- Always verify that the unit is operating properly before use. SONY WILL NOT BE LIABLE FOR DAMAGES OF ANY KIND INCLUDING, BUT NOT LIMITED TO, COMPENSATION OR REIMBURSEMENT ON ACCOUNT OF THE LOSS OF PRESENT OR PROSPECTIVE PROFITS DUE TO FAILURE OF THIS UNIT, EITHER DURING THE WARRANTY PERIOD OR AFTER EXPIRATION OF THE WARRANTY, OR FOR ANY OTHER REASON WHATSOEVER.

Chart of Optional Components and Accessories

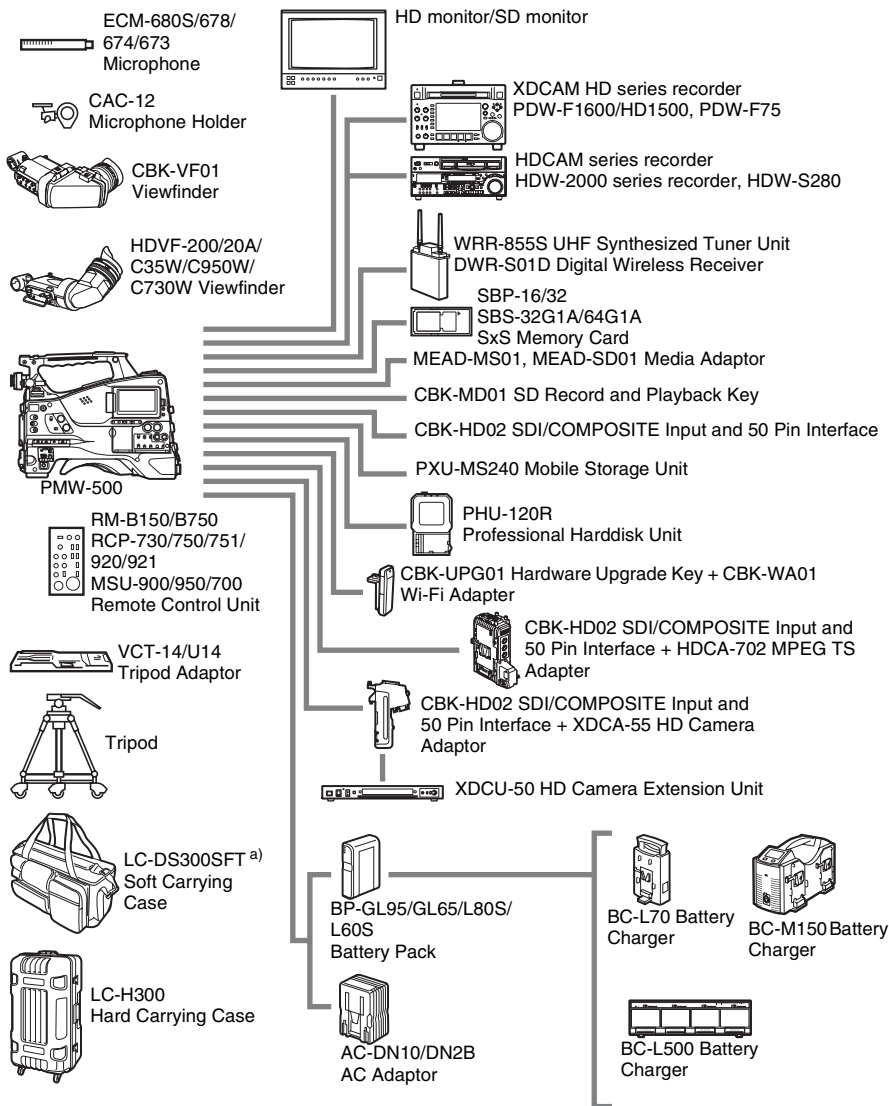

a) The carrying case is large enough to hold the camcorder with lens and microphone mounted. However, remove them if they protrude more than 25 cm (9 7/8 inches) from the front of the main unit.

About i.LINK

This section explains the specifications and features of i.LINK.

What is i.LINK?

i.LINK is a digital serial interface designed to integrate devices equipped with i.LINK connectors. i.LINK allows your device to:

- Perform two-way transmission and reception of data such as digital audio and digital video signals.
- Control other i.LINK devices.
- Easily connect multiple devices with a single i.LINK cable.

Your i.LINK device is capable of connecting to a wide range of digital AV devices for data transfer and other operations.

Other advantages include the following feature. When connected to multiple i.LINK devices, your i.LINK device can perform data transfer and other operations not only with the directly connected devices but also with any of the devices that are connected to those devices. Therefore, you do not need to be concerned with device connection order. However, depending on the features and specifications of the connected devices, you may need to use certain functions differently, and you may not be able to transfer data or perform certain operations.

i.LINK, a nickname for IEEE 1394 proposed by Sony, is a trademark supported by many companies worldwide.

IEEE 1394 is an international standard defined by IEEE, the Institute of Electrical and Electronics Engineers, Inc.

Note

The camcorder can be connected to one device with the i.LINK cable (DV cable). When you connect with an HDV or DV device that has two or more i.LINK connectors, refer to the Operating Instructions supplied with the connected device.

About data transfer speed of i.LINK

i.LINK defines a maximum data transfer speed of approximately 100, 200 and 400 Mbps¹⁾ that are described as S100, S200 and S400 respectively. For i.LINK devices, a maximum data transfer speed that the device supports is identified on “Specifications” page of the Operating Instructions supplied with the device or near its i.LINK connector.

- 1) When connecting with the device that support different data transfer speed, the actual data transfer speed may be different from those described on the i.LINK connectors.

What is Mbps?

Mega bits per second. A measure of the rate at which data is transmitted per second. In case of 100 Mbps, 100 Mega bits of data can be transmitted per second.

i.LINK operation with your camcorder

For details on operation when other equipment with i.LINK (HDV or DV) connector is connected, see page 171.

For details on connection with i.LINK cable and necessary software, refer to the Operating Instructions supplied with the connected device.

About the required i.LINK cable

Use the Sony 6-pin-to-4-pin or 6-pin-to-6-pin i.LINK cable to connect the i.LINK devices.

i.LINK and  are trademarks.

MPEG-4 Visual Patent Portfolio License

THIS PRODUCT IS LICENSED UNDER THE MPEG-4 VISUAL PATENT PORTFOLIO LICENSE FOR THE PERSONAL AND NON-COMMERCIAL USE OF A CONSUMER FOR

- (i) ENCODING VIDEO IN COMPLIANCE WITH THE MPEG-4 VISUAL STANDARD (“MPEG-4 VIDEO”) AND/OR
- (ii) DECODING MPEG-4 VIDEO THAT WAS ENCODED BY A CONSUMER ENGAGED IN A PERSONAL AND NON-COMMERCIAL ACTIVITY AND/OR WAS OBTAINED FROM A VIDEO PROVIDER LICENSED BY MPEG LA TO PROVIDE MPEG-4 VIDEO.

NO LICENSE IS GRANTED OR SHALL BE IMPLIED FOR ANY OTHER USE. ADDITIONAL INFORMATION INCLUDING THAT RELATING TO PROMOTIONAL, INTERNAL AND COMMERCIAL USES AND LICENSING MAY BE OBTAINED FROM MPEG LA, LLC. SEE [HTTP://WWW.MPEGLA.COM](http://WWW.MPEGLA.COM)

MPEG LA is offering licenses for (i) manufacturing/sales of any storage media storing MPEG-4 Visual video information (ii) distribution/broadcasting of MPEG-4 Visual video information in any manner (such as online video distribution service, internet broadcasting, TV broadcasting). Other usage of this product may be required to obtain license from MPEGLA. Please contact MPEG LA for any further information. MPEG LA, L.L.C., 250 STEELE STREET, SUITE 300, DENVER, COLORADO 80206, <http://www.mpegla.com>

MPEG-2 Video Patent Portfolio License

ANY USE OF THIS PRODUCT OTHER THAN CONSUMER PERSONAL USE IN ANY MANNER THAT COMPLIES WITH THE MPEG-2 STANDARD FOR ENCODING VIDEO INFORMATION FOR PACKAGED MEDIA IS EXPRESSLY PROHIBITED WITHOUT A LICENSE UNDER APPLICABLE PATENTS IN THE MPEG-2 PATENT PORTFOLIO, WHICH LICENSE IS AVAILABLE FROM MPEG LA, L.L.C., 250 STEELE STREET, SUITE 300, DENVER, COLORADO 80206.

“PACKAGED MEDIA” means any storage media storing MPEG-2 video information such as DVD movie which are sold/distributed to general consumers. Disc replicators or sellers of the PACKAGED MEDIA need to obtain licenses for their own business from MPEG LA. Please contact MPEG LA for any further information. MPEG LA, L.L.C., 250 STEELE STREET, SUITE 300, DENVER, COLORADO 80206 <http://www.mpegla.com>

About Bitmap Fonts

This product uses RICOH Bitmap Fonts produced and sold by Ricoh Company, Ltd.

About OpenSSL

Because it uses the OpenSSL Toolkit, this product uses software developed by the OpenSSL Project (<http://www.openssl.org/>).

OpenSSL License

```
/* =====  
* Copyright (c) 1998-2008 The OpenSSL Project. All rights reserved.  
*  
* Redistribution and use in source and binary forms, with or without  
* modification, are permitted provided that the following conditions  
* are met:  
*  
* 1. Redistributions of source code must retain the above copyright  
* notice, this list of conditions and the following disclaimer.  
*  
* 2. Redistributions in binary form must reproduce the above copyright  
* notice, this list of conditions and the following disclaimer in  
* the documentation and/or other materials provided with the  
* distribution.  
*  
* 3. All advertising materials mentioning features or use of this  
* software must display the following acknowledgment:  
* "This product includes software developed by the OpenSSL Project  
* for use in the OpenSSL Toolkit. (http://www.openssl.org/)"  
*  
* 4. The names "OpenSSL Toolkit" and "OpenSSL Project" must not be used to  
* endorse or promote products derived from this software without  
* prior written permission. For written permission, please contact  
* openssl-core@openssl.org.  
*  
* 5. Products derived from this software may not be called "OpenSSL"  
* nor may "OpenSSL" appear in their names without prior written  
* permission of the OpenSSL Project.  
*  
* 6. Redistributions of any form whatsoever must retain the following  
* acknowledgment:  
* "This product includes software developed by the OpenSSL Project  
* for use in the OpenSSL Toolkit (http://www.openssl.org/)"  
*  
* THIS SOFTWARE IS PROVIDED BY THE OpenSSL PROJECT ``AS IS'' AND ANY  
* EXPRESSED OR IMPLIED WARRANTIES, INCLUDING, BUT NOT LIMITED TO, THE  
* IMPLIED WARRANTIES OF MERCHANTABILITY AND FITNESS FOR A PARTICULAR  
* PURPOSE ARE DISCLAIMED. IN NO EVENT SHALL THE OpenSSL PROJECT OR  
* ITS CONTRIBUTORS BE LIABLE FOR ANY DIRECT, INDIRECT, INCIDENTAL,
```

- * SPECIAL, EXEMPLARY, OR CONSEQUENTIAL DAMAGES (INCLUDING, BUT
- * NOT LIMITED TO, PROCUREMENT OF SUBSTITUTE GOODS OR SERVICES;
- * LOSS OF USE, DATA, OR PROFITS; OR BUSINESS INTERRUPTION)
- * HOWEVER CAUSED AND ON ANY THEORY OF LIABILITY, WHETHER IN CONTRACT,
- * STRICT LIABILITY, OR TORT (INCLUDING NEGLIGENCE OR OTHERWISE)
- * ARISING IN ANY WAY OUT OF THE USE OF THIS SOFTWARE, EVEN IF ADVISED
- * OF THE POSSIBILITY OF SUCH DAMAGE.

=====

- * This product includes cryptographic software written by Eric Young
- * (eay@cryptsoft.com). This product includes software written by Tim
- * Hudson (tjh@cryptsoft.com).
- * /

Original SSLeay License

- /* Copyright (C) 1995-1998 Eric Young (eay@cryptsoft.com)
- * All rights reserved.
- * This package is an SSL implementation written
- * by Eric Young (eay@cryptsoft.com).
- * The implementation was written so as to conform with Netscapes SSL.
- * This library is free for commercial and non-commercial use as long as
- * the following conditions are aheared to. The following conditions
- * apply to all code found in this distribution, be it the RC4, RSA,
- * lhash, DES, etc., code; not just the SSL code. The SSL documentation
- * included with this distribution is covered by the same copyright terms
- * except that the holder is Tim Hudson (tjh@cryptsoft.com).
- * Copyright remains Eric Young's, and as such any Copyright notices in
- * the code are not to be removed.
- * If this package is used in a product, Eric Young should be given attribution
- * as the author of the parts of the library used.
- * This can be in the form of a textual message at program startup or
- * in documentation (online or textual) provided with the package.
- * Redistribution and use in source and binary forms, with or without
- * modification, are permitted provided that the following conditions
- * are met:
- * 1. Redistributions of source code must retain the copyright
- * notice, this list of conditions and the following disclaimer.
- * 2. Redistributions in binary form must reproduce the above copyright
- * notice, this list of conditions and the following disclaimer in the
- * documentation and/or other materials provided with the distribution.
- * 3. All advertising materials mentioning features or use of this software
- * must display the following acknowledgement:
- * "This product includes cryptographic software written by
- * Eric Young (eay@cryptsoft.com)"
- * The word 'cryptographic' can be left out if the rouines from the library

- * being used are not cryptographic related :-).
- * 4. If you include any Windows specific code (or a derivative thereof) from
- * the apps directory (application code) you must include an acknowledgement:
- * "This product includes software written by Tim Hudson (tjh@cryptsoft.com)"
- *
- * THIS SOFTWARE IS PROVIDED BY ERIC YOUNG ``AS IS" AND
- * ANY EXPRESS OR IMPLIED WARRANTIES, INCLUDING, BUT NOT LIMITED TO, THE
- * IMPLIED WARRANTIES OF MERCHANTABILITY AND FITNESS FOR A PARTICULAR PURPOSE
- * ARE DISCLAIMED. IN NO EVENT SHALL THE AUTHOR OR CONTRIBUTORS BE LIABLE
- * FOR ANY DIRECT, INDIRECT, INCIDENTAL, SPECIAL, EXEMPLARY, OR CONSEQUENTIAL
- * DAMAGES (INCLUDING, BUT NOT LIMITED TO, PROCUREMENT OF SUBSTITUTE GOODS
- * OR SERVICES; LOSS OF USE, DATA, OR PROFITS; OR BUSINESS INTERRUPTION)
- * HOWEVER CAUSED AND ON ANY THEORY OF LIABILITY, WHETHER IN CONTRACT, STRICT
- * LIABILITY, OR TORT (INCLUDING NEGLIGENCE OR OTHERWISE) ARISING IN ANY WAY
- * OUT OF THE USE OF THIS SOFTWARE, EVEN IF ADVISED OF THE POSSIBILITY OF
- * SUCH DAMAGE.
- *
- * The licence and distribution terms for any publically available version or
- * derivative of this code cannot be changed. i.e. this code cannot simply be
- * copied and put under another distribution licence
- * [including the GNU Public Licence.]
- */

Index

Symbols

! (warning) indicator 30

A

AC power 36
ACCESS lamps 21, 24
Accessories (optional) 191
Accessory fitting shoe 16
Adaptor connector 15
ALARM knob 18
Area setting 40
Arrow buttons (←, →, ↑, ↓) 22
ASSIGN. 0 switch 19
ASSIGN. 1/2/3 switches 18
ASSIGNABLE 4/5 switches 24
Assignable switches, assigning functions 155
ATW (Auto Tracing White Balance) 19
Audio control section 22
AUDIO IN CH-1/CH-2 connectors 26
AUDIO IN CH1/CH2/CH3/CH4
switches 23
AUDIO IN selectors 26
Audio input system 43
Audio level
adjusting 60
adjusting playback level 18
meters 34
AUDIO OUT connector 26
AUDIO SELECT CH1/CH2 switches 23
AUTO W/B BAL switch 17

B

BACKLIGHT button 22
BATT indicator 30
Battery
attachment shoe 15
of the internal clock, exchanging 186
pack 35
remaining 32
BKW-401 38

Black balance, adjusting 54
BRIGHT control 28, 29
Brightness level 33

C

Camera adaptor 15
Camera operator tally indicator 28
Clip Continuous Rec 83
Clip(s)
batch copy 103
copying 102
cue up 94
defining names 88
deleting 77, 103
displaying properties 100
dividing 106
operating with a computer 169
operations 91
playing 76, 94
protecting 102
proxy data 85
selecting 94
Clock setting 41
COLOR TEMP. button 18
Color temperature 32
Connection 167
monitors 167
using i.LINK 171
CONTRAST control 28, 29
Cover 20

D

Date, setting 41
DC IN connector 15
DC OUT 12V connector 15
DCC (Dynamic Contrast Control) 19
Depth of field indication 32
Digital extender 31
Diopter adjustment ring 28, 29
DISP SEL/EXPAND button 21
DISPLAY switches 22, 29
DISPLAY/ASPECT switch 28

E

EARPHONE jack 26
EJECT buttons 24
Electric color temperature filter 33

- ESSENCE MARK button 23
- Essence mark thumbnail screen 105
- Expand thumbnail screen
 - displaying 104
 - to increase the number of divisions 105
- Extender 31
- External device connector 24
- External devices 167
 - control 33
- External input 33
- External power source 32
- Eyecup 28, 29

- F**
- F FWD button/indicator 21
- F REV button/indicator 21
- Filter position 33
- FILTER selector 17
- Fitting for optional microphone holder 16
- Flange focal length, adjusting 42
- Focus
 - adjustment mode 33
 - position 31
- Formatting 70, 73
- Frame Rec 81
- Framing 76, 84
- Framing shots 84
- Freeze Mix 84
- F-RUN/SET/R-RUN switch 23

- G**
- GAIN selector 19
- Gain value 34
- GENLOCK IN connector 25
- Green tally 31
- Green tally indicator 30

- H**
- HD/SD SDI OUT connector 26
- Histogram 34
- HOLD button 22

- I**
- i.LINK 192
 - cable 192
 - connection 171
- i.LINK (HDV/DV) connector 26
- Index picture 93
 - changing 106
- Indicators and status display 28
- Initial value 110
- Input source 33
- Internal clock 41
- Interval Rec 79
- Iris
 - position 34

- L**
- LCD monitor 20, 26
- LCD panel 20
- Lens
 - cable clamp 16
 - locking lever 17
 - mount 17
 - mount cap 17
 - mount securing rubber 16
 - mounting 42
- LENS connector 16
- Lens file(s)
 - loading 164
 - loading automatically 165
 - saving 164
 - setting data 164
- LEVEL CH1/CH2/CH3/CH4 knobs 23
- LIGHT connector 16
- LIGHT switch 15
- Line input audio equipment, connecting 47
- Live & Play 76

- M**
- Maintenance 174
- Media
 - remaining capacity 27, 34
 - status 31
- MENU button 22
- MENU CANCEL/PRST/ESCAPE switch 19
- MENU knob 17
- MENU ON/OFF switch 19
- MIC IN (+48 V) connector 16
- MIC LEVEL control 18
- Microphone holder 29, 30
 - fitting 16
- Microphone, connecting 43
- MIRROR switch 29

MONITOR knob 18
MONITOR switches 18
Monitor, connecting 167
MPEG TS adapter 15

N

ND filter 17
NEXT button 21
Nonlinear editing 170, 172
Number of system lines 32

O

OK/NG/KP mark(s) 92, 101
 adding 101
 deleting 101
 setting 78
Operation status 31
 of i.LINK device 33
Optional components 191
OUTPUT/DCC switch 19

P

PC connector 24
PEAKING control 28, 29
Picture Cache 78
Planning metadata 87
PLAY/PAUSE button/indicator 21
Plug 28, 29
Power source voltage/battery remaining
 capacity 32
Power supply 35
POWER switch 15
Preset values, resetting 162
PRESET/REGEN/CLOCK switch 23
PREV button 21
Proxy data 85

R

REC START button 17
Recording 85
 external input signals 172
 from pre-stored video 78
 indicators 30
 on an external device 171
 proxy data 85
 remaining time 71

 review 75
 shot marks 77
 time-lapse video 79
Recording mode 53
 special settings indication 31, 32
Red tally indicators 30
REMOTE connector 26
Reset 110, 162
RESET/RETURN button 22

S

Scene file(s)
 loading 163
 saving 162
SDI IN connector 25
Search
 with the essence mark thumbnail screen
 95
 with the expand thumbnail screen 95
SET button 22
Setup menu 107
 basic operations 109
 FILE menu 150
 MAINTENANCE menu 135
 menu list 111
 OPERATION menu 112
 PAINT menu 129
 USER menu 111
SHIFT button 23
Shooting 68
 basic operations 74
 stop motion animations 81
 with Slow & Quick motion 82
Shot data 65
Shot ID 65
Shot mark(s)
 adding 106
 adding during playback 95
 defining names 90
 deleting 106
 recording 77
Shoulder pad 16
 adjusting the position 50
Shoulder strap fitting 16
Shoulder strap, using 49
Shutter
 setting 57
 speed 57
SHUTTER selector 17

Slot cover 24
 SLOT SELECT button 25
 Speaker 20
 Specifications 186
 Status information 66
 Status screens 66
 ASSIGN SWITCH 66
 AUDIO 66
 BATTERY/MEDIA 67
 CAMERA 66
 VIDEO 66
 STOP button 21
 Stopper 28, 29
 SxS memory card slots 24
 SxS memory cards 68
 ejecting 70
 formatting 70
 loading 69
 restoring 72
 selecting 70
 System configuration 173

T

Tally indicator 28, 29
 TALLY indicators 26
 TALLY switch 26, 28, 29
 TC IN connector 25
 TC OUT connector 25
 Testing 174
 THUMBNAIL button 22
 THUMBNAIL indicator 22
 THUMBNAIL menu 96
 operations 98
 Thumbnail screen 91
 displaying OK clip thumbnails only 98
 displaying the all clips thumbnail 99
 Thumbnail(s)
 changing the screen type 98
 operations 96
 Time, setting 41
 Timecode 33
 setting 62
 synchronizing 63
 TLCS automatic adjustment 59
 TLCS control mode 33
 Tripod mount 16
 Tripod, mounting 48

U

UHF portable tuner, attaching 45
 USB flash drive 73
 formatting 73
 User bits setting 63
 User file(s) 160, 165
 User setting data
 loading 161
 saving 160

V

Video format 101
 setting 51
 Video level indication 33
 Video light, connecting 49
 VIDEO OUT connector 25
 Viewfinder 29
 adjusting focus 39
 adjusting position 37
 adjusting screen 39
 attaching 37
 cable 30
 cleaning 174
 connectors 16
 detaching eyepiece 39
 fitting shoe 16
 HDVF-20A (optional) 28
 positioning knob 16
 positioning lever 16
 positioning ring 16
 screen 30
 screen display 30
 status display 30
 Viewfinder cable 29
 Voltage capacity 32
 VTR SAVE indicator 30

W

WARNING indicator 21
 Warnings 176
 WHITE BAL switch 19
 White balance memory 33
 White balance, adjusting 55
 Wi-Fi adapter 24
 Wireless microphone reception level 32
 Write protect 69

Z

ZEBRA switch 28, 29

Zoom

position 31

The material contained in this manual consists of information that is the property of Sony Corporation and is intended solely for use by the purchasers of the equipment described in this manual.

Sony Corporation expressly prohibits the duplication of any portion of this manual or the use thereof for any purpose other than the operation or maintenance of the equipment described in this manual without the express written permission of Sony Corporation.

Free Manuals Download Website

<http://myh66.com>

<http://usermanuals.us>

<http://www.somanuals.com>

<http://www.4manuals.cc>

<http://www.manual-lib.com>

<http://www.404manual.com>

<http://www.luxmanual.com>

<http://aubethermostatmanual.com>

Golf course search by state

<http://golfingnear.com>

Email search by domain

<http://emailbydomain.com>

Auto manuals search

<http://auto.somanuals.com>

TV manuals search

<http://tv.somanuals.com>