

IMPORTANT FOR FUTURE REFERENCE

Please complete this information and retain this manual for the life of the equipment:

Model #: _____

Serial #: _____

Date Purchased: _____

OPERATOR'S MANUAL

FOR MODEL EZ-3 and EZ-5

Simple Steam COUNTERTOP STEAMERS



Model EZ-3



Model EZ-5

 **WARNING**

Improper installation, operation, service, or maintenance can cause property damage, injury, or death.
Read this manual thoroughly before installing and operating this equipment.

1100 Old Honeycutt Road, Fuquay-Varina, NC 27526

www.southbendnc.com

MANUAL 1178387 REV 5
\$18.00



EZ COUNTERTOP STEAMERS
MANUAL SECTION ST

SAFETY PRECAUTIONS

Before installing and operating this equipment, be sure everyone involved in its operation is fully trained and aware of precautions. Accidents and problems can be caused by failure to follow fundamental rules and precautions.

The following symbols, found throughout this manual, alert you to potentially dangerous conditions to the operator, service personnel, or to the equipment.



This symbol warns of immediate hazards which will result in severe injury or death.



This symbol refers to a potential hazard or unsafe practice which could result in injury or death.



This symbol refers to a potential hazard or unsafe practice which could result in injury, product damage, or property damage.

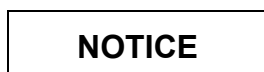

This symbol refers to information that needs special attention or must be fully understood, even though not dangerous.

WARNING **FIRE HAZARD**

For your safety, do not store or use gasoline or other flammable vapors and liquids in the vicinity of this or any other appliance.

Keep area around appliances free and clear of combustibles.

WARNING **SHOCK HAZARD**

Do not open panels that require use of tools.

Unit must be cleaned daily and properly maintained to reduce chances of unsafe operating conditions.

WARNING **BURN HAZARD**

Watch for clogged drain - can create burn hazard when door is opened.

Stand back when opening doors - hot steam or hot water may escape from steamer.

NOTICE

Be sure this Operator's Manual and important papers are given to the proper authority to retain for future reference.

Congratulations! You have purchased one of the finest pieces of heavy-duty commercial cooking equipment on the market.

You will find that your new equipment, like all Southbend equipment, has been designed and manufactured to meet the toughest standards in the industry. Each piece of Southbend equipment is carefully engineered and designs are verified through laboratory tests and field installations. With proper care and field maintenance, you will experience years of reliable, trouble-free operation. **For best results, read this manual carefully.**

RETAIN THIS MANUAL FOR FUTURE REFERENCE.

Table of Contents

Specifications	4
Installation	5
Operation.....	9
Cooking Hints	10
Cleaning	13
Troubleshooting.....	15
Parts	40

Read these instructions carefully before attempting installation. Installation and initial startup should be performed by a qualified installer. Unless the installation instructions for this product are followed by a qualified service technician (a person experienced in and knowledgeable with the installation of commercial gas an/or electric cooking equipment) then the terms and conditions on the Manufacturer’s Limited Warranty will be rendered void and no warranty of any kind shall apply.

In the event you have questions concerning the installation, use, care, or service of the product, write to:

Southbend
1100 Old Honeycutt Road
Fuquay-Varina, North Carolina 27526 USA

The serial plate is located on the right side of the unit near the back and top (see Figure 2 on page 7).



SPECIFICATIONS

DIMENSIONS

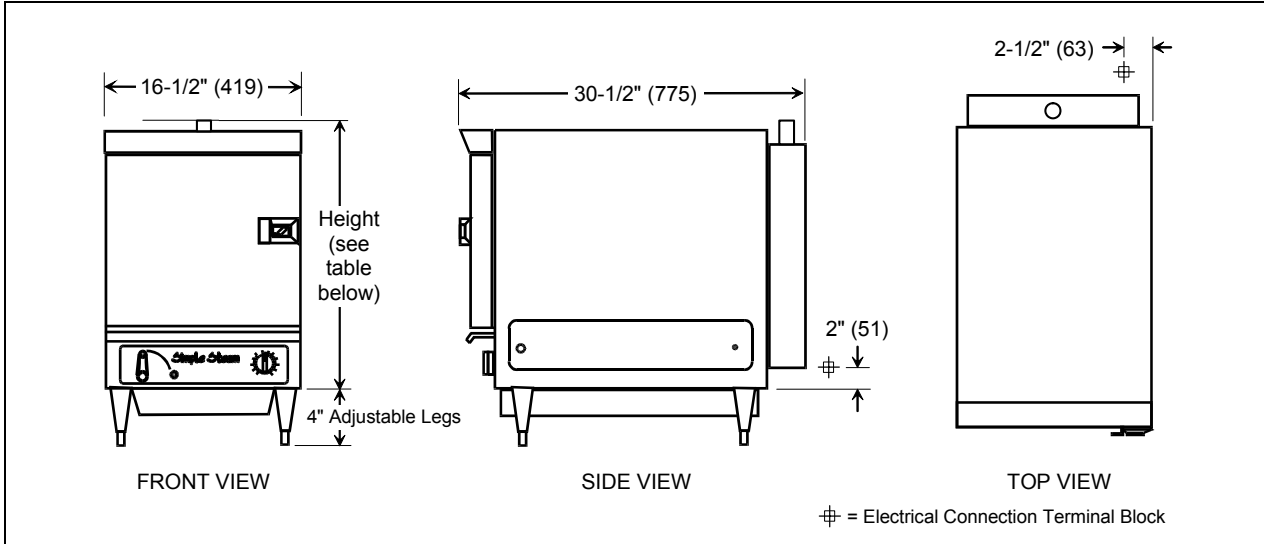

Model	Height *	Interior Dimensions			Pan Capacity**			Crate Dimensions				Crated Weight
		Width	Depth	Height	1"	2.5"	4"	Width	Depth	Height	Volume	
EZ-3	21" (533)	13-1/2" (343)	22" (559)	9-1/2" (241)	6	3	2	19-1/2" (495)	31-1/2" (800)	28-1/2" (724)	10.1 cu. ft. 0.29 cu. m.	150 lbs. 68 kg.
EZ-5	27-1/8" (689)	13-1/2" (343)	22" (559)	15-1/2" (394)	9	5	3	20" (508)	34" (864)	38" (965)	15.0 cu. ft. 0.43 cu. m.	175 lbs. 79.4 kg.

* Add 4" to height if 4" adjustable legs are used.

** "Pan Capacity" is the number of 1", 2.5", or 4" high standard pans (12" wide x 20" deep) that the steamer will hold.

IMPORTANT: UNIT MUST BE LEVEL FOR PROPER OPERATION. WARRANTY WILL BE VOIDED FOR IMPROPER INSTALLATION.

ELECTRICAL REQUIREMENTS

One fused electrical connection is required to the terminal block of the steamer. All units are shipped per customer order, three phase or single phase. (A kit is available for field conversion to three phase or single phase.) The fused connection must be wired for the required voltage and maximum amperage as listed in the chart below:

Total Connected Amps	Max. Amps per Line			
	EZ-3		EZ-5	
	1 Phase	3 Phase	1 Phase	3 Phase
208 V 60 Hz	40	24	57	33
220 V 50/60 Hz	38	23	54	31
240 V 60 Hz	35	21	49	29
380/220 V 50 Hz	23	14	31	19
415/240 V 50 Hz	21	13	29	17
480 V 60 Hz	18	13	25	15



INSTALLATION

WARNING

DO NOT CONNECT 3/4" ID GREY HOSE IN REAR OF UNIT TO ANYTHING. THESE ARE VENT HOSES AND MUST BE ALLOWED TO DRAIN INTO PAN. FAILURE TO COMPLY COULD CAUSE A DANGEROUS PRESSURE RISE INSIDE OF THE STEAMER.

CAUTION

Do not locate unit adjacent to any high heat or grease producing piece of equipment, such as a range top, griddle, fryer, etc., that could allow radiant heat to raise the exterior temperature of the steam body above 130°F (54°C). DO NOT MOUNT ABOVE OTHER COOKING EQUIPMENT.

NOTICE

These installation procedures must be followed by qualified personnel or warranty will be void.

Local codes regarding installation vary greatly from one area to another. The National Fire Protection Association, Inc. states in its NFPA 96 latest edition that local codes are the "authority having jurisdiction" when it comes to installation requirements for equipment. Therefore, installations should comply with all local codes.

The unit, when installed, must be electrically grounded and comply with local codes, or in the absence of local codes with the National Electrical Code ANSI/NFPA 70-latest edition.

Canadian installation must comply with CSA-Standard (C22.2 No. 109-M1981 General Requirements-Canadian Electrical Code, Part II. 109-M1981) Commercial Cooking Appliances.

Step 1: Unpacking

IMMEDIATELY INSPECT FOR SHIPPING DAMAGE

All containers should be examined for damage before and during unloading. The freight carrier has assumed responsibility for its safe transit and delivery. If damaged equipment is received, either apparent or concealed, a claim must be made with the delivering carrier.

Apparent damage or loss must be noted on the freight bill at the time of delivery. The freight bill must then be signed by the carrier representative (Driver). If the bill is not signed, the carrier may refuse the claim. The carrier can supply the necessary forms.

A request for inspection must be made to the carrier within 15 days if there is concealed damage or loss that is not apparent until after the equipment is uncrated. The carrier should arrange an inspection. Be certain to hold all contents plus all packing material.



Step 2: Install the Legs

1. Uncrate carefully. Report any hidden damage to the freight carrier IMMEDIATELY.
2. Do not remove any tags or labels until unit is installed and working properly.
3. Remove placeholder bolts holding bottom cover onto unit and discard.
4. Screw legs into the bottom of the unit until approximately 1/4" of thread is showing. The legs with rubber suction cups go on the back of unit.
5. Slip drain pan guides into place between legs and bottom of steamer, as shown in Figure 1, making sure that pan stops are toward the rear of the unit.
6. Tighten legs, making sure that the pan guides stay seated against the leg threads.
7. To level the unit, adjust the base of unit's legs.
8. Place custom drain pan under unit.

Figure 1

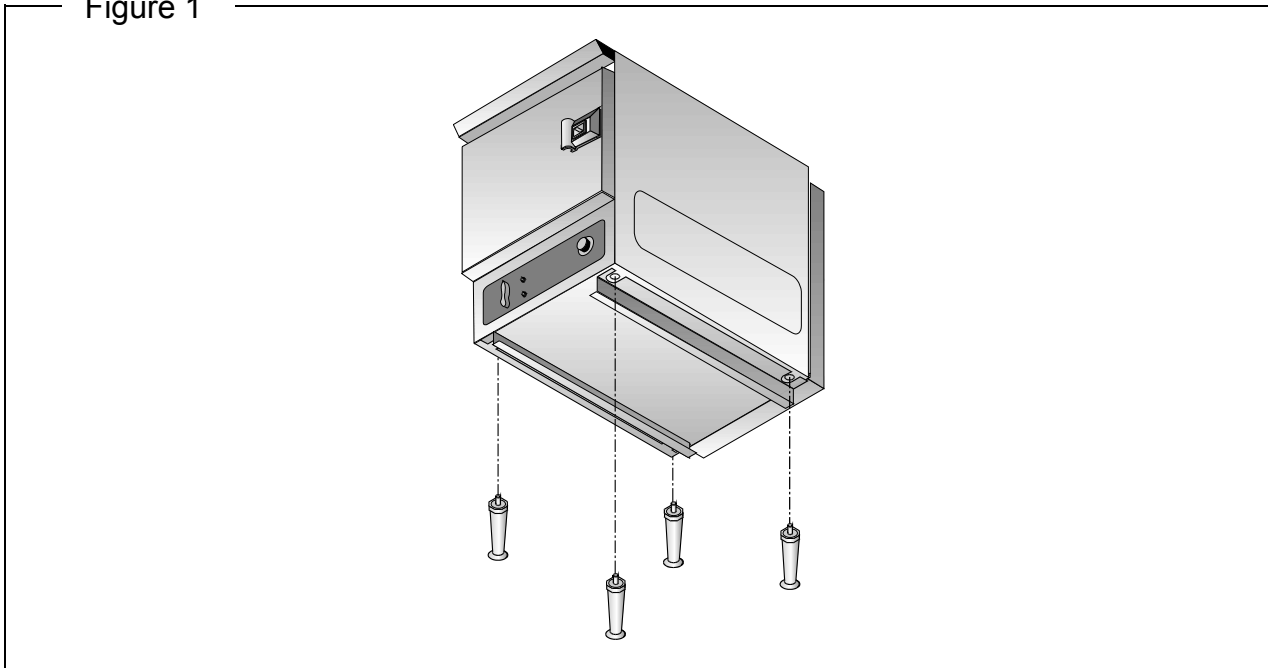

NOTICE

Unit must be level to assure maximum performance. Improper leveling may void warranty.

CAUTION

WATER FROM A FULL CAVITY CANNOT BE HELD IN A 12" x 20" X 2½" PAN..



Step 3: Electric Connection

A field connection terminal block is located at the rear of the unit, lower left side. A hole is provided for a 3/4" conduit fitting (solid or flex). The rear cover must be removed to gain access to terminal block (see Figure 2).

Be sure that the input voltage matches the requirement on the serial plate. The unit is factory wired per customer order.

WARNING

A POSITIVE GROUND CONNECTION IS ESSENTIAL. DO NOT ALLOW ANY TAMPERING OR ADJUSTMENT OF ANY CONTROL OR WIRING. THE UNIT IS FACTORY SET. ADJUSTING ANY INTERNAL COMPONENT CAN VOID THE WARRANTY.

THIS UNIT REQUIRES A KIT TO BE FIELD CONVERTED FROM THREE-PHASE TO SINGLE-PHASE OR VICE-VERSA. CONSULT FACTORY FOR PHASE CHANGES.

All 208-220-240 and 480 volt units will have three terminal block sections, "L1-L2-L3", for use with either 3-wire 3-phase or 2-wire, single-phase, 50 or 60 Hz. All 380V and 415V units will have four terminal block sections, "L1-L2-L3-N," for use with European style 4-wire 3-phase with neutral.

Figure 2

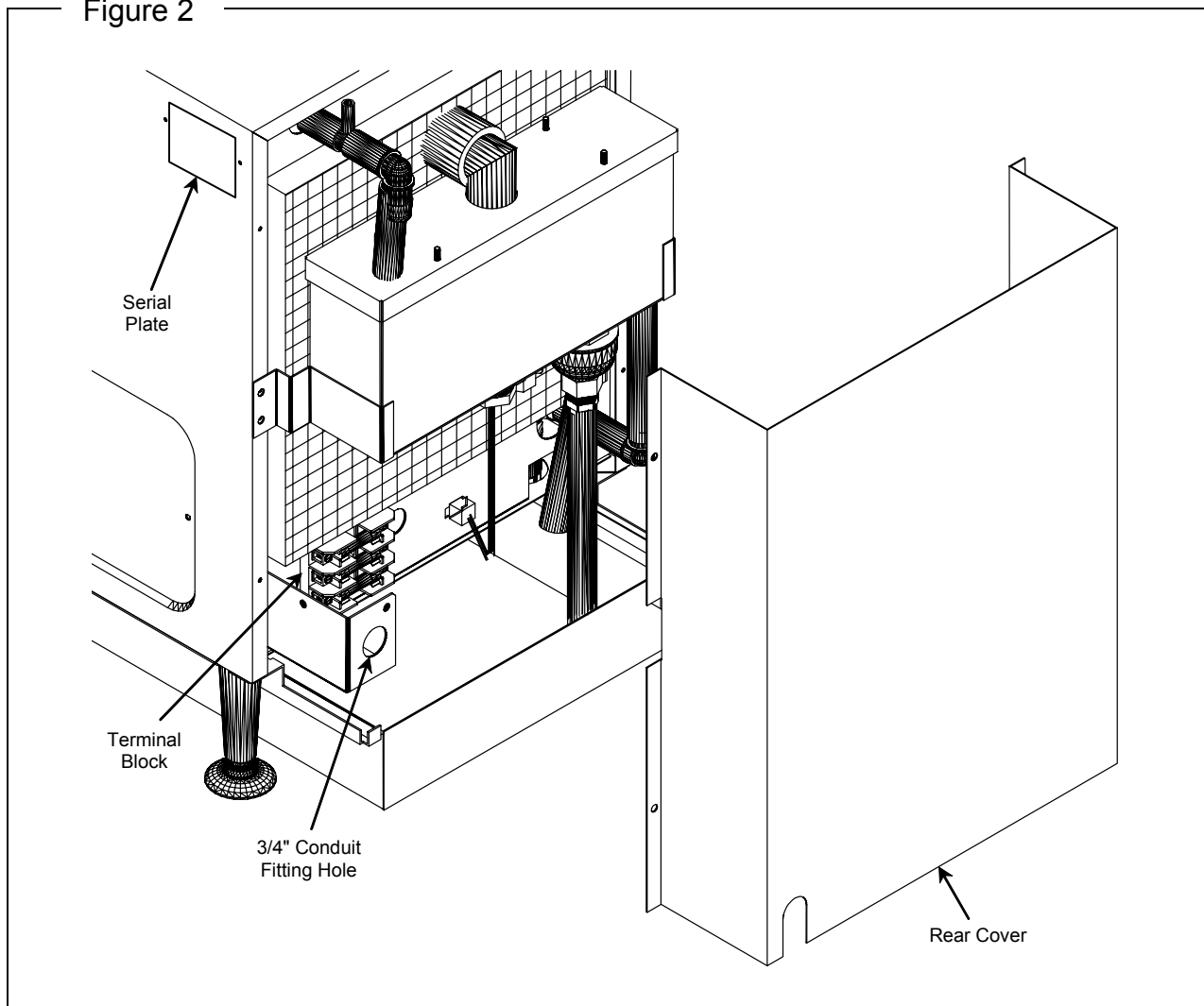



INSTALLATION

Step 4: Optional Floor Drain

The drain valve is 1/2" NPT. Position the unit near, but not on top of, an open floor drain. Allow at least a 1" air gap.

DO NOT directly plumb to the unit unless you also install an "open funnel" downstream of this connection in the drain system. The "open funnel" is intended to eliminate any water from entering the steamer because of a blocked drain. Any connection that allows the build-up of back pressure in the unit (such as a reduction in pipe size to a line smaller than 1/2" or a 90 degree angle in the line prior to the "open funnel" drain discharge point) may cause personal or property damage and will therefore void the warranty. (See Figure 3.)

Figure 3

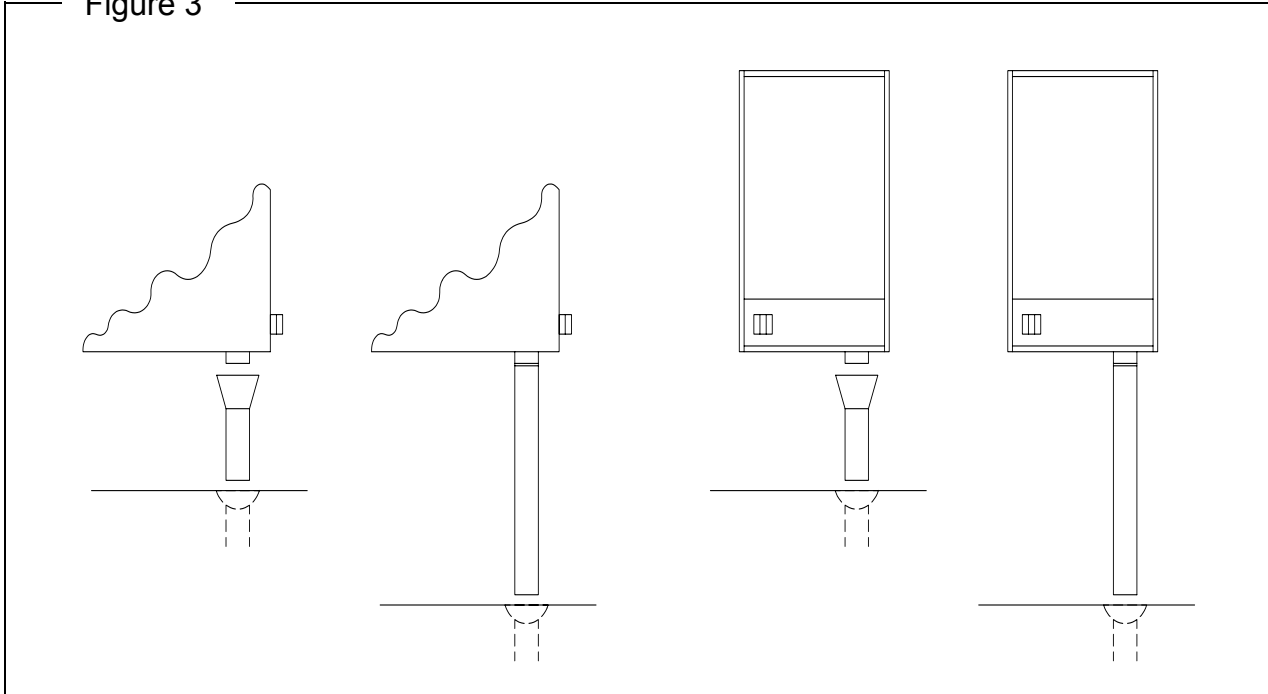

Step 5: Check Installation

The following items should be checked within the first 30 days of operation by a qualified service technician.

1. Check doors for proper alignment.
2. Ensure proper opening and closing of doors.
3. Open door and remove cavity bottom cover, if present.
4. Ensure that the light comes on when lever is set to the "ON" position.
5. Pour approximately 2 gallons of water into trough, ensuring that the cavity bottom is covered.
6. An audible "click" should be heard when the door switch actuator rod is depressed and held. This indicates proper functioning of the contactor as it closes. Release rod.
7. Depress and hold the door switch for 2 minutes. The contactor should close when the switch is first depressed and stay closed during this period.
8. Close the door and wait approximately 12 minutes until the contactor opens, indicating the unit has reached operating temperature.



OPERATION

STARTUP

1. If the cavity bottom cover is present, open door and remove.
2. Turn lever to "ON" position with door open.
3. **Important:** Pour water into trough above the door until water is observed passing through the fill / drain opening at left rear corner of cavity bottom.
4. Add additional water through trough or through door up to "-WATER LEVEL-" mark (approximately 2 gallons to fill an empty unit).

NOTICE: WATER SPECIFICATION

To meet warranty requirements, supply water must meet the following specification:

Total Dissolved Solids (TDS).....	60 PPM
Hardness	2 Grains or 35 PPM
pH Factor	7.0 to 7.5

OPERATION

5. Replace cavity bottom cover (if present).
6. Unit will be ready for cooking in approximately 12 minutes.

OPERATION

1. Suggested cooking times for various foods are shown in the table in the following section.
2. Pan specifications are shown on specifications page (page 4).
3. The door may be opened or closed at any time.
4. Unit will automatically idle at operating temperature when and if the door is closed and there is no food in the cavity.
5. Timer can be used as desired. However, it has no effect on unit operation.
6. Add proper amount of water through the trough (above the door) or directly through the door when water level is low.
7. If unit runs out of water the "CHECK WATER LEVEL" light will illuminate. Follow step # 6, above.

SHUTDOWN

1. The custom drain pan or a 12"x 20"x 4" non-perforated stainless steel pan should be located under the unit at all times.
2. Turn lever to the "OFF" position.
3. Empty drain pan after allowing water to cool.
4. Remove pan guides and cavity bottom cover (if present).
5. Wipe out steamer (with Lime-A-Way or equivalent deliming solution as necessary), RINSE THOROUGHLY WITH CLEAN WATER.
6. Ensure drain opening is clear.
7. Replace pan guides and cavity bottom cover (if present).
8. Leave the door open at night after cleaning.
9. DO NOT USE high-chlorine or bleach solution for cleaning the door gasket.
10. DO NOT USE steel wool or other metallic pads in the steamer.



COOKING HINTS

COOKING TIPS

Schedule cooking of fresh vegetables so that they will be served soon after they are cooked. If it is necessary to prepare them in advance, they can be plunged into cold water, drained thoroughly and held under refrigeration until needed for service.

Five pounds of cold cooked vegetables can be reheated in the steamer in 5 to 10 minutes, depending upon the variety.

SUGGESTED COOKING TIMES

Timer settings are for general guidance only. Differences in food quality, size, shape, freshness, load size, and desired degree of doneness must be taken into consideration and adjustments made in time, if necessary.

COOKING HINTS

Product	Weight	Portions	Cooking Time (minutes)	Pan Used
Asparagus				
Fresh	3½ lbs.	14 (4 oz.)	8-10	Full/Perforated
Frozen Spears (Thawed)	5 lbs.	20 (4 oz.)	9	Full/Perforated
Beans				
Green - Frozen, Cut	5 lbs.	20 (4 oz.)	12	Full/Perforated
Green - Fresh	5 lbs.	20 (4 oz.)	15-17	Full/Perforated
Wax - Frozen	5 lbs.	20 (4 oz.)	13	Full/Perforated
Lima - Frozen	5 lbs.	20 (4 oz.)	10	Full/Perforated
Broccoli				
Spears - Fresh	4 lbs.	16 (4 oz.)	10-12	Full/Perforated
Spears - Frozen (Thawed)	5 lbs.	20 (4 oz.)	8	Full/Perforated
Brussel Sprouts				
Fresh	5 lbs.	20 (4 oz.)	15-17	Full/Perforated
Fresh	5 lbs.	20 (4 oz.)	13	Full/Perforated
Carrots				
Frozen - Whole Baby	5 lbs.	20 (4 oz.)	12	Full/Perforated
Fresh - ¼-inch Bias Cut	5 lbs.	20 (4 oz.)	12	Full/Perforated
Cabbage				
Green, Cut Into Wedges		24	15	Full/Perforated
Red, Cut Into Wedges		16	18-20	Full/Perforated
Cauliflower				
Fresh, Whole	2 lbs.	8 (4 oz.)	9-10	Full/Perforated
Fresh, Whole	2 lbs. 12 oz.	11 (4 oz.)	15	Full/Perforated
Frozen, Flowerettes	5 lbs.	20 (4 oz.)	10-12	Full/Perforated
Corn				
Fresh, Cob, 4-5 Inch Ears	5½ lbs.	15	13-15	Full/Perforated
Frozen - Whole Kernel	5 lbs.	20 (4 oz.)	8	Full/Perforated
Frozen - Cob, 6 Inch Ears	9 lbs.	14	12-14	Full/Perforated

Table continues on next page.

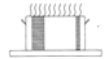

Table continuing from previous page.

Product	Weight	Portions	Cooking Time (minutes)	Pan Used
Mixed Vegetables				
Frozen	5 lbs.	20 (4 oz.)	12	Full/Perforated
Peas				
Frozen	5 lbs.	20 (4 oz.)	8	Full/Perforated
Potatoes				
Red Bliss - Whole	7 lbs.	28	35	Full/Perforated
Russetts - Whole	8 lbs.	20	25-35	Full/Perforated
Russetts - Peeled	5 lbs.	12	20	Full/Perforated
Russetts 1-Inch Cubes	5 lbs.	20 (4 oz.)	17	Full/Perforated
Spinach				
Fresh, Leaf	2½ lbs.	10 (4 oz.)	5	Full/Perforated
Frozen, Chopped	6 lbs.	24 (4 oz.)	35	Full/Perforated
Zucchini				
Fresh - Slices ¼-inch Thick	5 lbs.	20 (4 oz.)	6-8	Full/Perforated
Broccoli				
Spears - Fresh	4 lbs.	16 (4 oz.)	10-12	Full/Perforated
Spears - Frozen (Thawed)	5 lbs.	20 (4 oz.)	8	Full/Perforated
Eggs				
Large - Hard Cooked	12 lbs.	12	15-16	½ Perforated
Meats				
Corned Beef	6¾ lbs.	18 (6 oz.)	2 hours	Full
Hot Dogs, Thawed	5 lbs.	40 (2 oz.)	5	Full/Perforated
Hot Dogs, Frozen	5 lbs.	40 (2 oz.)	10	Full/Perforated
Fowl				
Boneless Chicken Breast	4½ lbs.	12 (6 oz.)	15	Full/Perforated
Tamales, Frozen	3 lbs.	12 (4 oz.)	20	Full/Perforated
Tortilla, Frozen 8-Inch	4 Tortillas	4	45 Seconds	Half/Perforated
Beef Ravioli, Frozen	48 Ravioli (1 lb. 8 oz.)	8	5-6	Full/Perforated
Elbow Macaroni	2 lbs. Uncooked	32 (2 oz.)	7	In Perforated Pan Nested in Solid Pan
Spaghetti	2 lbs. Uncooked	32 (2 oz.)	14	In 4-Inch Full/Perforated
Egg Noodles	2 lbs. Uncooked	32 (2 oz.)	10	Full/Perforated
Converted Rice	2 lbs. 2½ Qts. Water + Oil & Salt		25	Full/Perforated
Navy Beans	2 lbs.			Full/Perforated
Place beans in pan and cover with 3-quarts hot tap water. Steam for 2 minutes; remove from steamer and cover for 1 hour. Remove cover and place back in steamer for 40 minutes.				

Table continues on next page.



Table continuing from previous page.

Product	Weight	Portions	Cooking Time (minutes)	Pan Used
Black Eyed Peas Place beans in pan and cover with 3-quarts hot tap water. Steam for 2 minutes; remove from steamer and cover for 1 hour. Remove cover and place back in steamer for 35 minutes.	2 lbs.			Full/Perforated
Oysters	5 lbs.	16 Count	12	Perforated Pan Nested in Full Pan 2½-Inch Deep
Shrimp, Fresh, Medium, Heads Removed	5 lbs.		6-7	Full/Perforated
Shrimp, Frozen, Large, Peeled & Deveined	5 lbs.		8	Full/Perforated
Lobster	1¾ lbs.		8	Full/Perforated
Alaskan King Crab Legs	1 lb.		4-5	Full/Perforated
Cherrystone Clams	5 lbs.	12	7	Full/Perforated
Fish Fillets	7½ lbs.	12 (10 oz.)	18	Full/Perforated Nested in Full Hotel Pan

COOKING HINTS

- For eggs cooked in the shell, adding salt to the cooking water increases cooking efficiency and decreases cooking time. If the egg cracks, the white is cooked at the crack and is sealed right away.
- To avoid green yolk (which is a deposit of iron sulfide) chill the eggs immediately after removing from the steamer by plunging them into a cold water bath (preferably containing ice).
- A quick and easy way to cook eggs for a salad mixture is to crack them directly into a solid steam table pan which has been lightly coated with salad oil. Do not mix. Steam until they are hard cooked. Remove and chop as you would for egg salad. The job of peeling is eliminated.
- Transfer steamed hot chicken to deep pan, cover with Cacciatore Sauce and finish in oven. Bake 20 to 30 minutes. May be held on steam table.
- Chicken, sausage, and/or fish may be browned in Infra-Red or Radiant Broiler after steaming by brushing with melted margarine mixed with salad oil to give a golden brown color.
- Save juices from steamed chicken or turkey to make soups, sauces, or casserole dishes.
- Chicken may be steamed in advance and refrigerated for next day's use. Be sure to bring product back to 180°F before serving.
- Save the juice from the corned beef. After the cabbage has been steamed, place it in a solid pan and add the juice for flavoring and holding on a steam table.
- Steaming brisket is a definite time saver. Boiling in water takes 40 to 50 minutes per pound. Using the Simple Steam can save 50% in cooking time.
- Cabbage, when steamed, retains its color and wedge identity. It will not break apart as it does when boiled in an open pot.
- When removing items prepared in a perforated pan, place a solid pan underneath the perforated pan with the cooked food in order to prevent dripping on the floor.
- The Simple Steam is designed to accept standard 12 x 20 pans. Fractional size pans and dishes can be used as well with the optional perforated shelf.
- For stirring, the pan does not have to be removed from the steamer. Pull pan 1/3 way out of the cavity and the entire surface is accessible.
- The door may be opened at any time during operation to remove or add food.



CLEANING

Southbend equipment is constructed with the best quality materials and is designed to provide durable service when properly maintained. To expect the best performance, your equipment must be maintained in good condition and cleaned daily. Naturally, the frequency and extent of cleaning depends on the amount and degree of usage.

Following daily and more extensive periodic maintenance procedures will increase the life of your equipment. Climatic conditions (i.e., salt air, seasonings, and water quality) may result in the need for more thorough and more frequent cleaning in order to keep equipment performing at optimal levels.

WARNING: BURN HAZARD

For proper and safe operation, this steamer must be cleaned daily as described in this manual. Failure to do so could result in serious injury or damage.

Drains must be kept clean and clear of debris.

WARNING: SHOCK HAZARD

DO NOT GET WATER IN THE CONTROLS.
This could result in expensive repairs and/or electrical shock.

De-energize all power to equipment before cleaning the equipment.

DAILY CLEANING

1. Turn lever to the "OFF" position.
2. Remove pan guides.
3. Clean all interior surfaces with soap, water, and a non-metallic pad. Occasional use of a deliming solution such as Lime-A-Way is recommended. **RINSE THOROUGHLY WITH CLEAN WATER.**
4. Ensure drain opening is clear.
5. Clean drain cover.
6. Replace pan guides.
7. Leave the door open at night after cleaning to prolong the life of the gasket.

PERIODIC CLEANING

- If lime or mineral deposit starts to build up in the interior, clean the unit by using Southbend "descaler" or other non-caustic deliming solution. Follow manufacturer's recommended procedures. Thoroughly rinse out unit with clean water.
- To remove normal dirt, grease, or product residue from stainless steel, use ordinary soap and water applied with a sponge or cloth. Dry thoroughly with a clean cloth. **Never use vinegar or any corrosive cleaner.**
- Occasionally drain rear water box. To remove grease and food splatter or condensed vapors that have baked on the equipment, apply cleanser to a damp cloth or sponge and rub cleanser on the metal in the direction of the polishing lines on the metal. Rubbing cleanser as gently as possible in the direction of the polished lines will not mar the finish of the stainless steel. **NEVER RUB WITH A CIRCULAR MOTION.** Soil and burnt deposits which do not respond to the above procedure can usually be removed by rubbing the surface with SCOTCH-BRITE scouring pads. **DO NOT USE ORDINARY STEEL WOOL**, as any



particles left on the surface will rust and further spoil the appearance of the finish. NEVER USE A WIRE BRUSH, STEEL SCOURING PAD, SCRAPER, FILE OR OTHER STEEL TOOLS. Surfaces which are marred collect dirt more rapidly and become more difficult to clean. Marring also increases the possibility of corrosive attack. Refinishing may then be required.

SEMIANNUAL CLEANING

At least twice a year, have your Southbend Authorized Service Agency or another qualified service technician clean and adjust the unit for maximum performance. Semiannual cleaning should include the following:

1. Remove rear cover.
2. Place a (1) gallon container under the water seal box drain valve (see Figure 18 on page 29).
3. Open drain valve, and close valve when box is finished draining.
4. Add one gallon of deliming solution to the trough above the door.
5. Add two gallons of deliming solution through the door into the cavity
6. Turn unit on, let run for 30 minutes.
7. Turn unit off and drain all solution from the cavity.
8. Drain solution from water seal box as in steps 2 and 3.
9. Fill unit with clean water THROUGH THE TROUGH and drain. Repeat 2 times.

Consult the Southbend Authorized Parts/Service Distributor list for the Authorized Service Representative in your area or contact Southbend at 1-800-348-2558 for this information.



TROUBLESHOOTING

This section contains a troubleshooting flowcharts, procedures, and electric schematics to assist a qualified service technician in the servicing of a EZ-3 or EZ-5 Countertop Steamer.

TROUBLESHOOTING FLOWCHARTS

Find the symptom below that corresponds to the malfunction, then turn to the corresponding figure and page. Follow the flowchart on that page until the problem is solved.

Symptom	Page
Unit Not Heating Up, "ON" Light Not Lit	16
Unit Not Heating Up Properly or Not Cooking As Fast, "ON" Light Lit	17
Unit Using Excessive Amount of Water and/or Excessive Steam Coming from Vent Tube	18
"Check Water Level" Light Does Not Come On When Unit Runs Out of Water	18
Buzzer Does Not Come On	19

TROUBLESHOOTING PROCEDURES AND SCHEMATICS

Procedure or Schematic	Page
Voltage Check at Control Panel Fuse Block	20
Heating Element Resistance Check (at contactor)	21
Main Fuse Replacement (for units built before July 1, 2002)	22
Power Switch Continuity Check	23
Contactor Coil and MOV Check	24
Idle Element Resistance Check (for units built before January 15, 2001)	25
Timer and Buzzer Check	26
Door Switch Continuity Check (for units built before January 15, 2001)	27
Door Switch Continuity Check (for units built after January 15, 2001)	28
Float Switch Continuity Check	29
High Limit Continuity Check (for units built before January 15, 2001)	30
High Limit Continuity Check (for units built after January 15, 2001)	31
Time Delay Relay Check (for EZ-3 units built before January 15, 2001)	32
Controller Check (for EZ-5 units and for EZ-3 units built after January 15, 2001)	33
Electric Schematic for 208-240 Volt 60 Hz or 220 Volt 50 Hz Model EZ-3 Units Built Before Jan. 15, 2001	34
Electric Schematic for 480 Volt Model EZ-3 Units Built Before Jan. 15, 2001	35
Electric Schematic for 208-240 Volt 60 Hz or 220 Volt 50 Hz Model EZ-5 Units Built Before Jan. 15, 2001	36
Electric Schematic for 480 Volt Model EZ-5 Units Built Before Jan. 15, 2001	37
Electric Schematic for 208-240 Volt 60 Hz or 220 Volt 50 Hz Units (EZ-3 or EZ-5) Built After Jan. 15, 2001	38
Electric Schematic for 480 Volt Units (EZ-3 or EZ-5) Built After January 15, 2001	39



Figure 4

Unit Not Heating Up, "ON" Light Not Lit

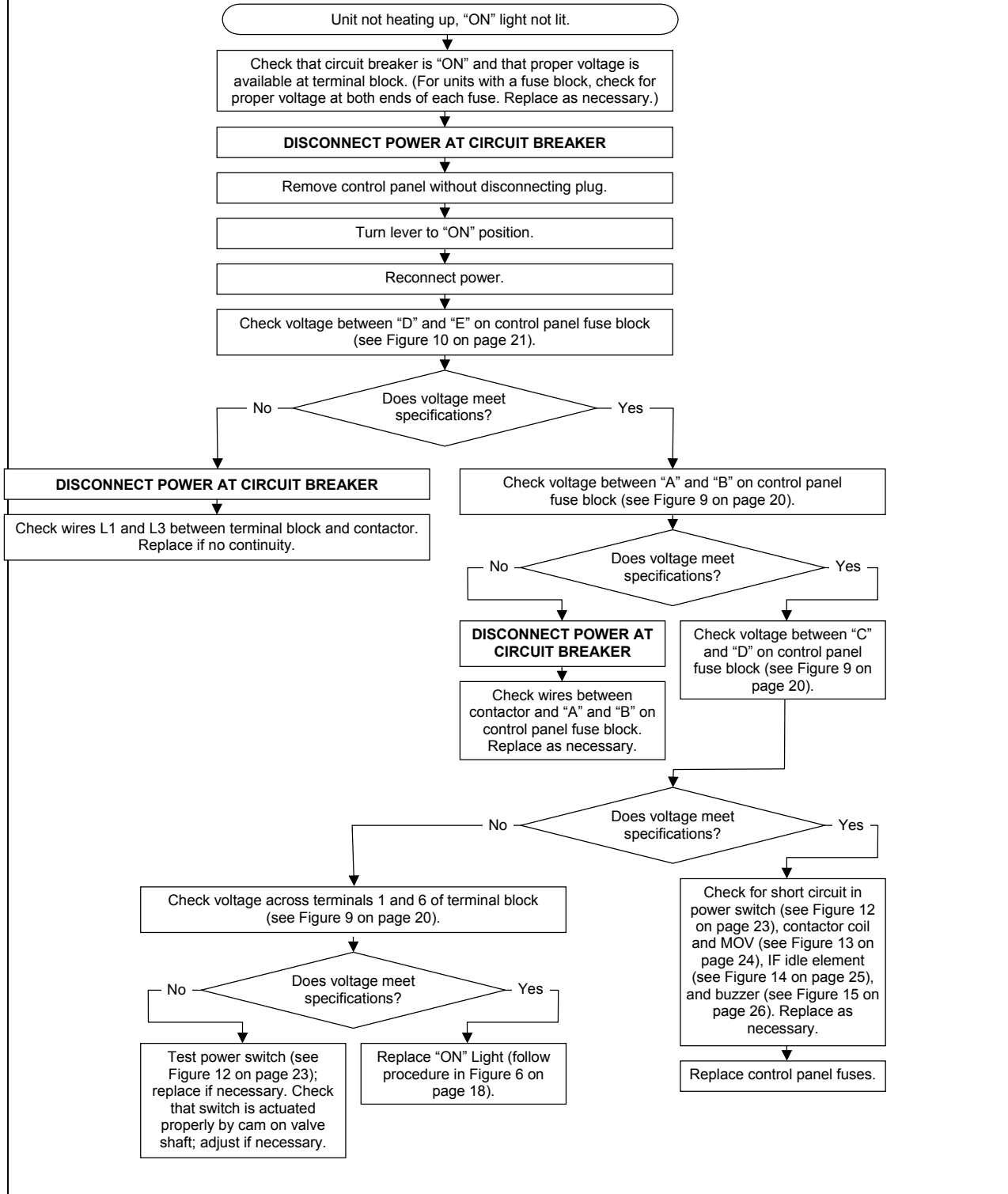

TROUBLESHOOTING



Figure 5

Unit Not Heating Up Properly or Not Cooking As Fast, "ON" Light Lit

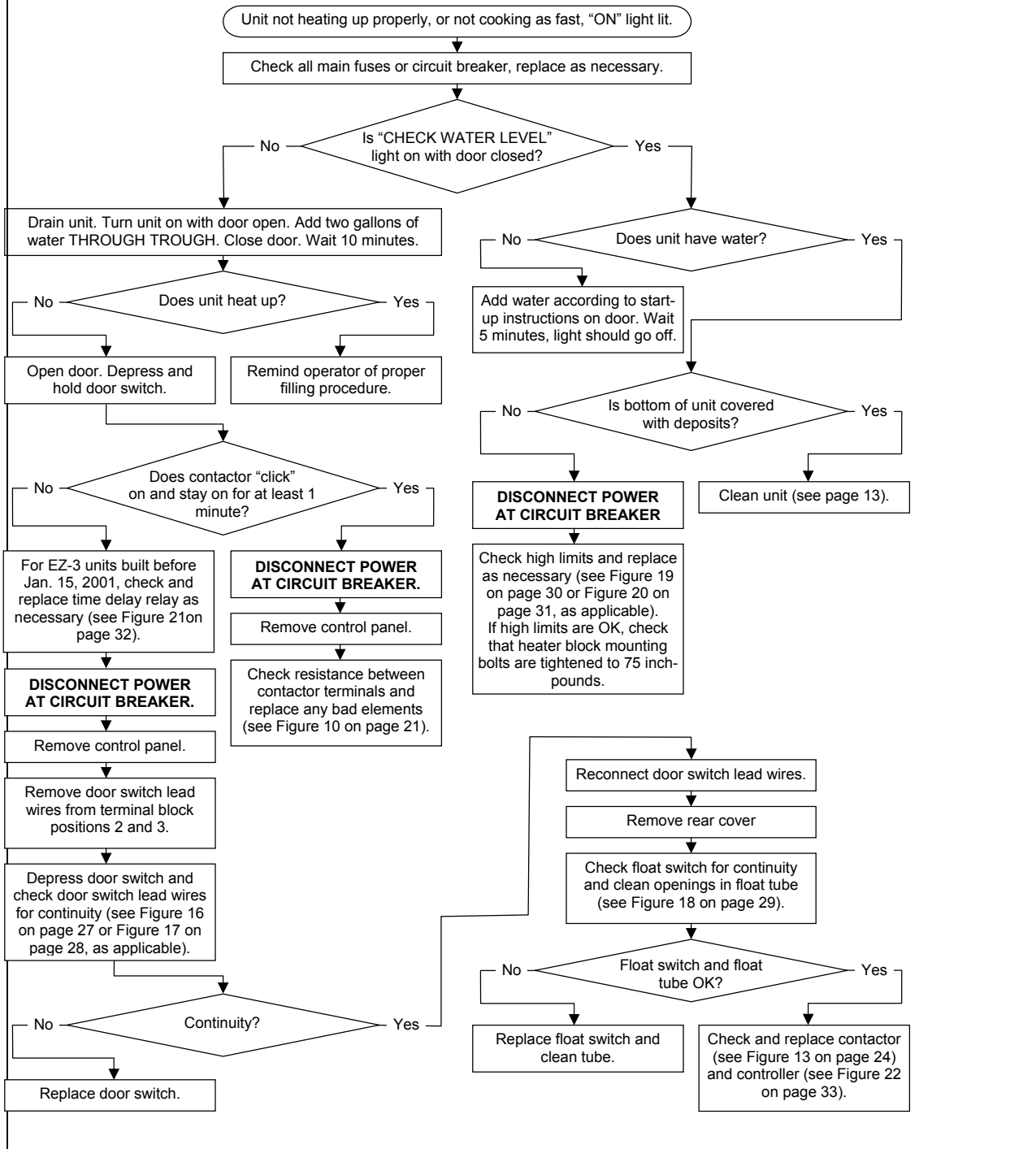

TROUBLESHOOTING



Figure 6

Unit Using Excessive Amount of Water and/or Excessive Steam Coming from Vent Tube

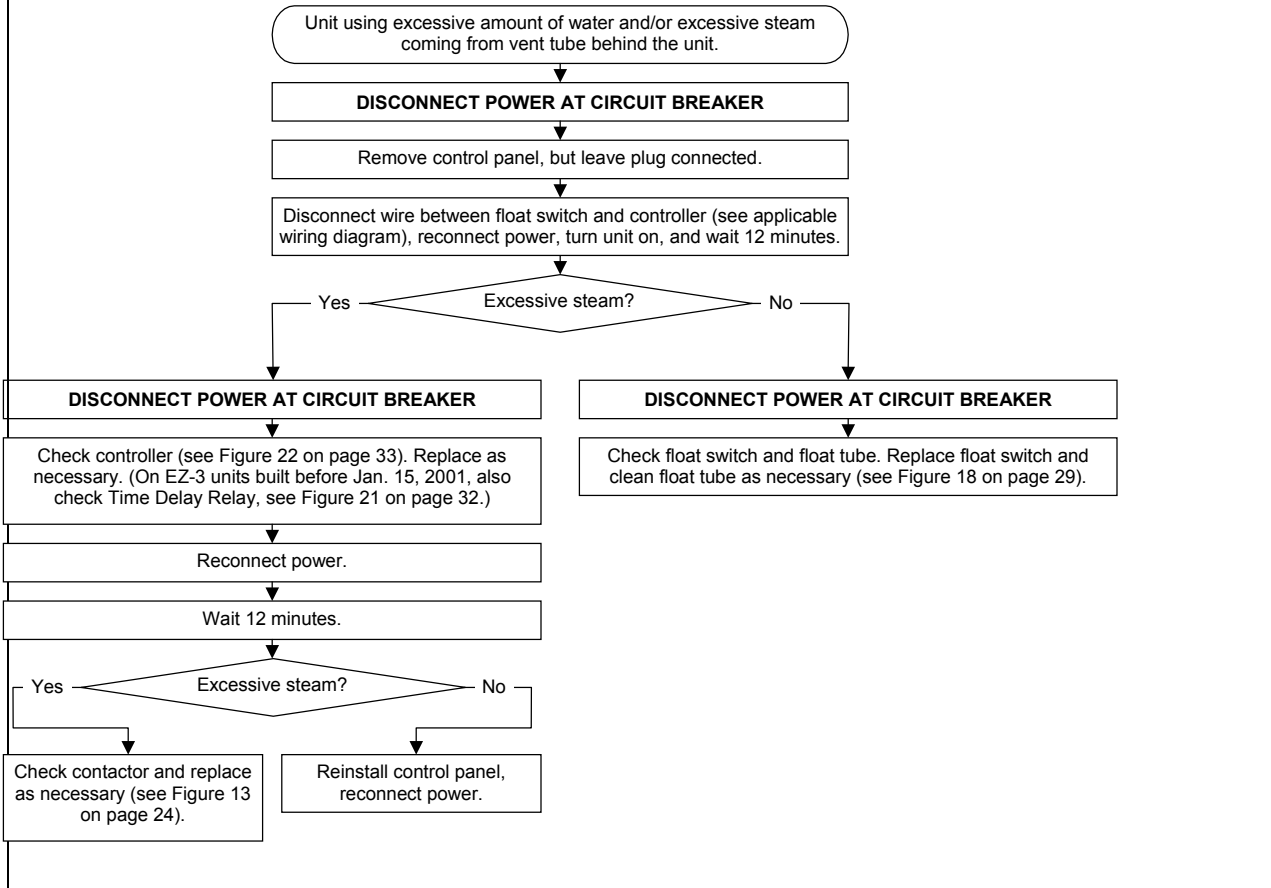
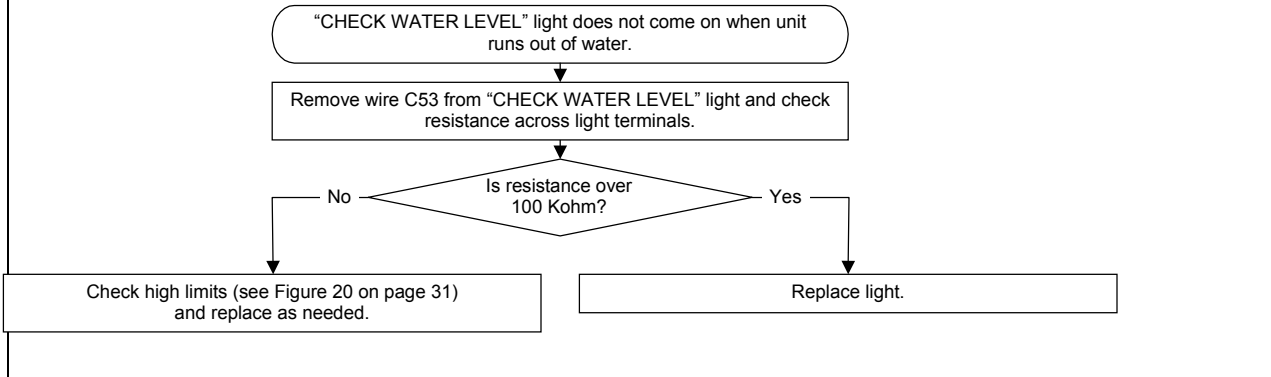

Figure 7

“Check Water Level” Light Does Not Come On When Unit Runs Out of Water



TROUBLESHOOTING



Figure 8

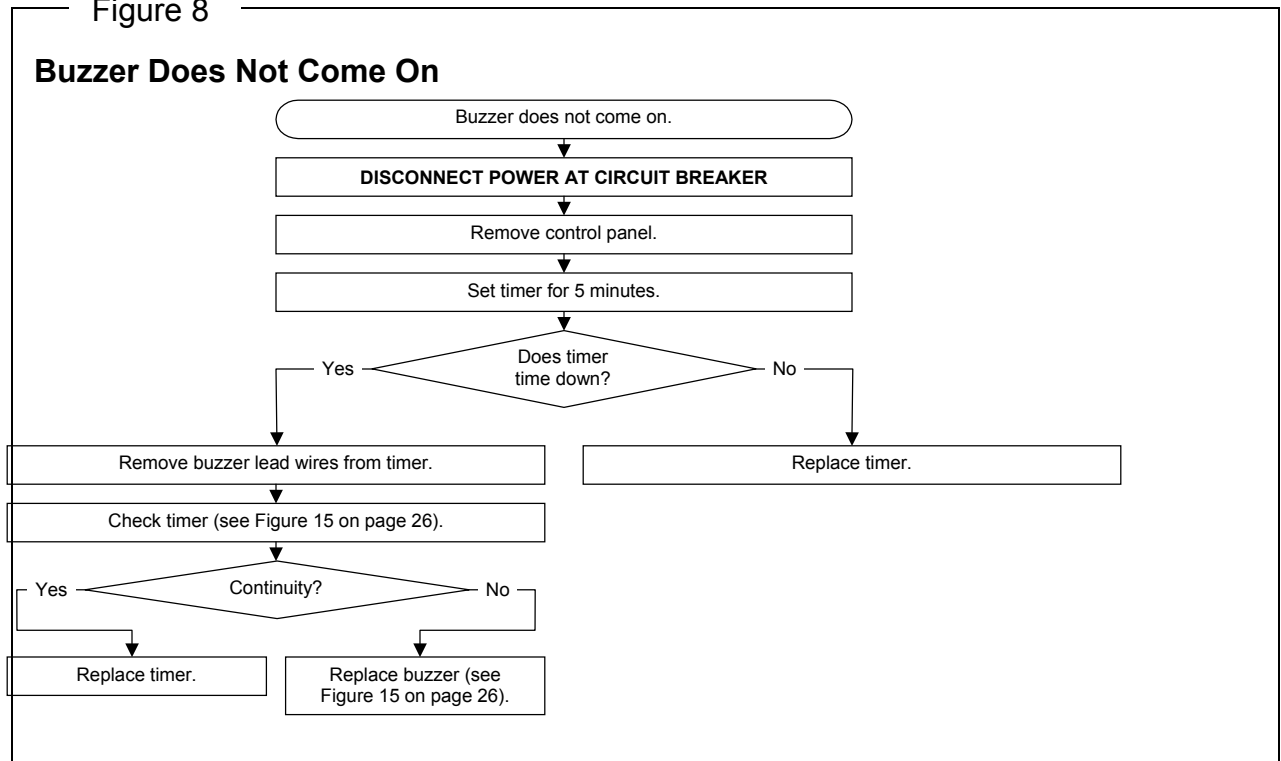
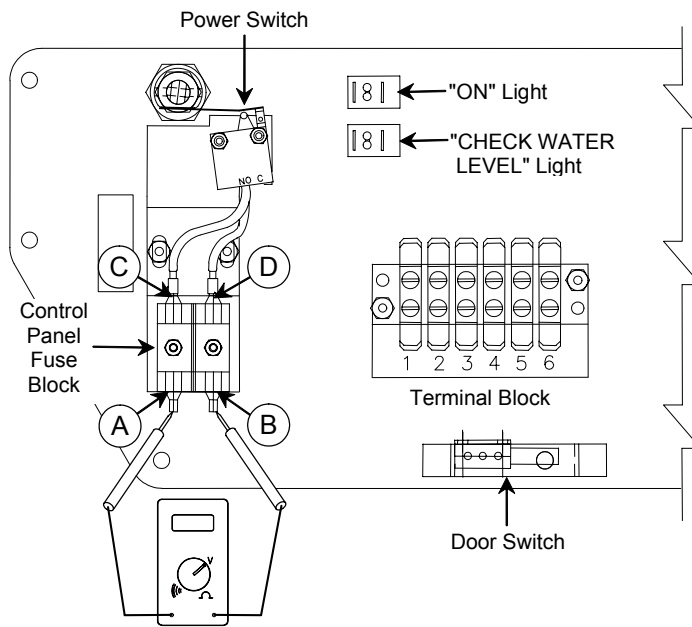



Figure 9

Voltage Check at Control Panel Fuse Block



1. Disconnect power at circuit breaker.
2. Remove control panel without disconnecting plug.
3. Turn lever to "ON" position.
4. Reconnect power.
5. Place leads as shown.
6. Check voltage.

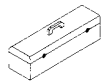
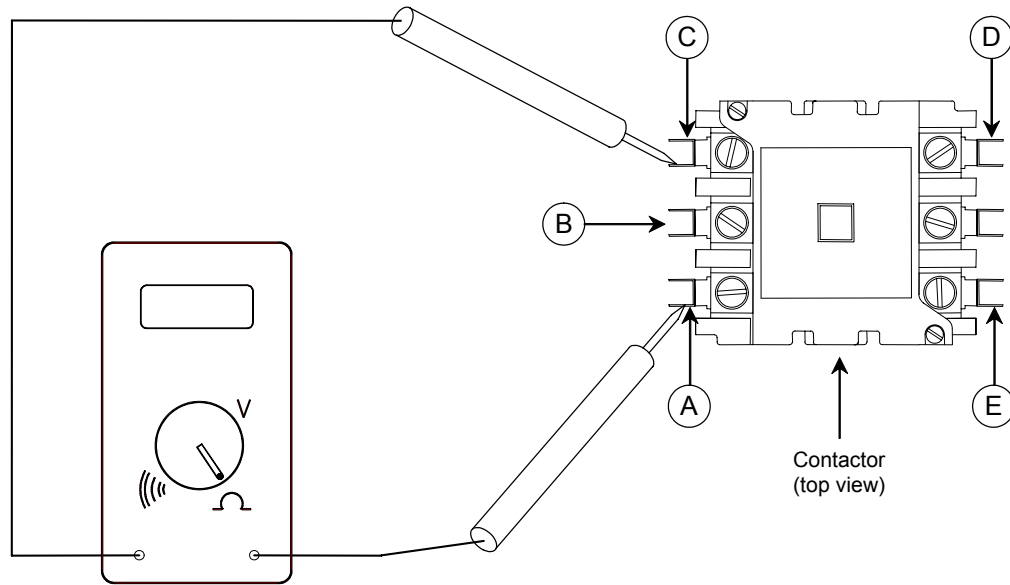

Figure 10

Heating Element Resistance Check (at contactor)



1. Disconnect power at circuit breaker.
2. Remove control panel.
3. Place test leads between terminals A and C on left side of contactor.
4. Check the resistance and compare to the allowable range in the following table:

Voltage	Model EZ-3 Allowable Resistance (Ohms)	Model EZ-5 Allowable Resistance (Ohms)
208	8 to 16	6 to 12
220	9 to 18	7 to 13
240	11 to 21	8 to 15
380	28 to 53	21 to 39
415	34 to 63	24 to 46
480	45 to 84	33 to 61

5. Check resistance between terminals A and B and between terminals B and C similarly.

TROUBLESHOOTING



Figure 11

Main Fuse Replacement (for units built before July 1, 2002)

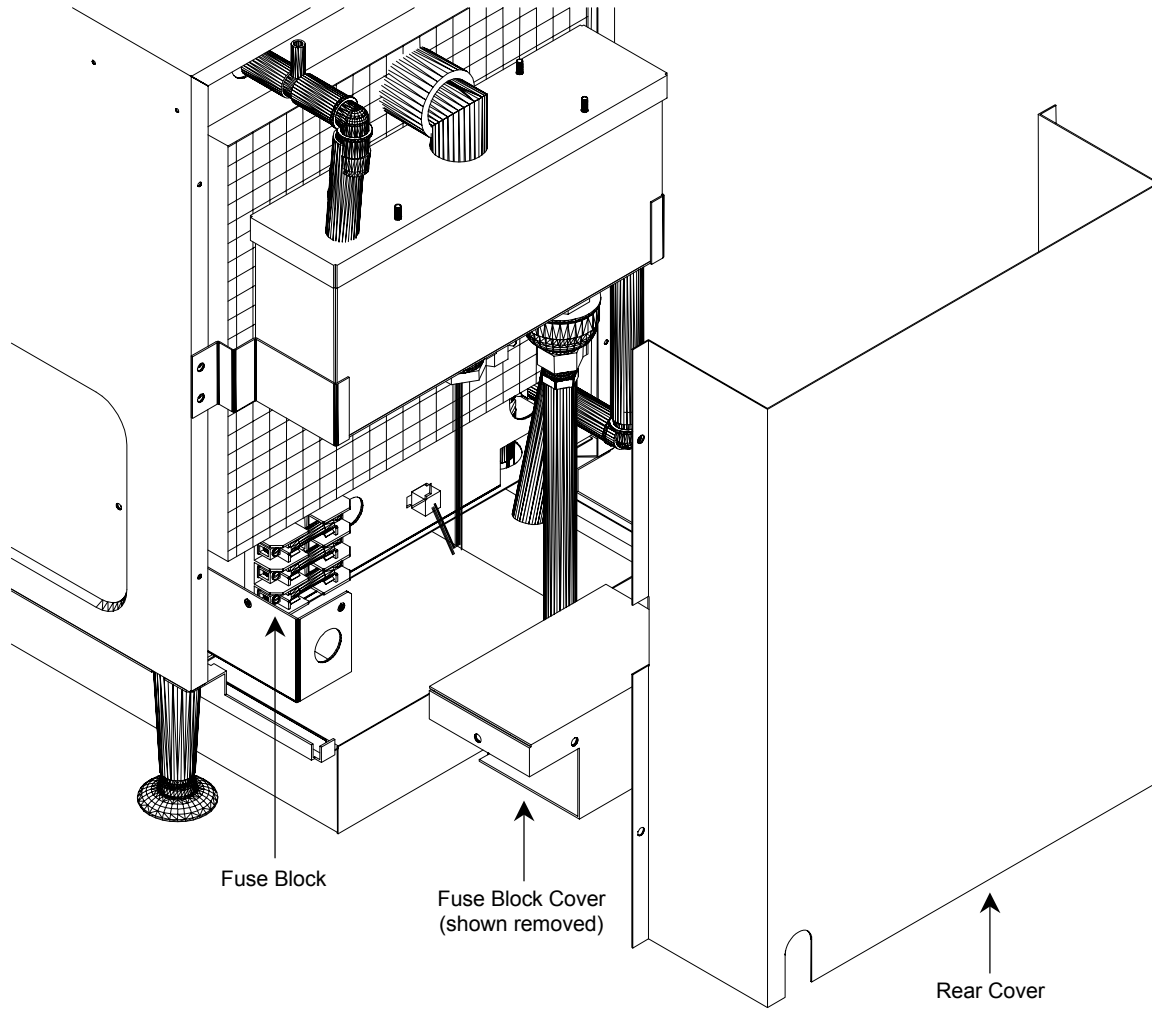

1. Disconnect power at circuit breaker.
2. Remove rear cover from unit.
3. Remove fuse block cover.
4. Check fuses for continuity.
5. Replace as necessary.

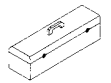
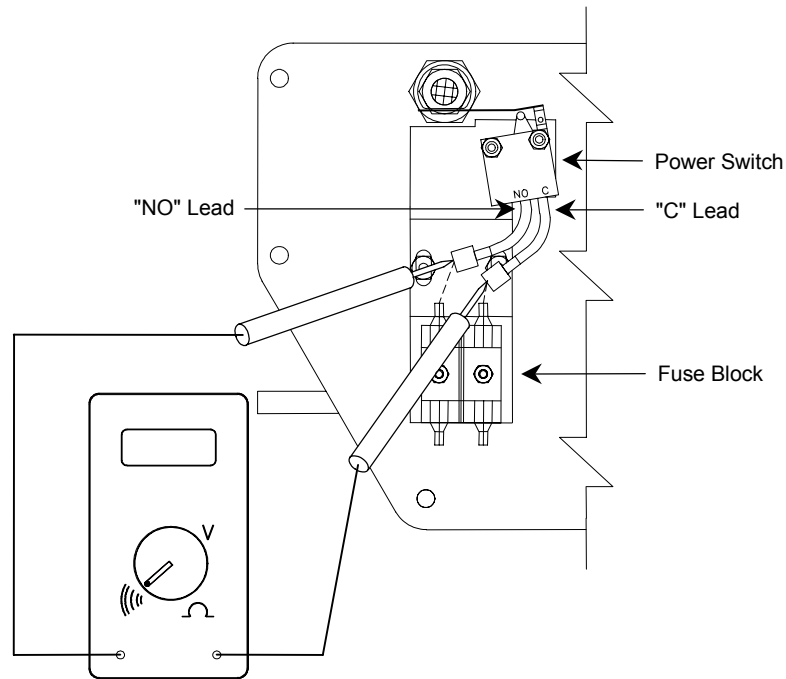

Figure 12

Power Switch Continuity Check



1. Disconnect power at circuit breaker.
2. Remove control panel.
3. Turn Lever to "ON" from "OFF" and to "OFF" from "ON" ensuring that the power switch is properly actuated.
4. Remove power switch lead wires from fuse block (note wire locations).
5. Place test leads on "C" and "NO" lead wires as shown.
6. Check for continuity with lever in "OFF" position (there should be no continuity).
7. Check for continuity with lever in "ON" position (there should be continuity).
8. Repeat steps 5 - 7 with test leads between other pair of "C" and "NO" lead wires.
9. Place one test lead on "NO" lead wire and other test lead on other "NO" lead wire.
10. Check for continuity with lever in "ON" position and then with lever in the "OFF" position (there should be no continuity when the lever is in either position).
11. Reconnect wires or replace switch as necessary.

TROUBLESHOOTING



Figure 13

Contactor Coil and MOV Check

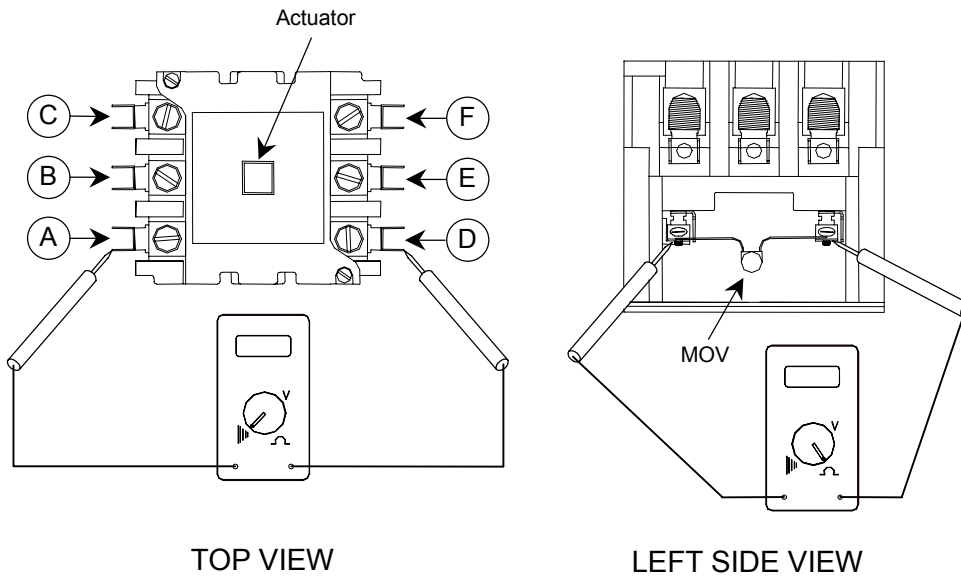

1. Disconnect power at circuit breaker.
2. Remove control panel and disconnect nine-pin plug PL1.
3. Depress actuator on top of contactor. Actuator should travel freely and spring back when released.
4. Check for continuity between contacts A and D as shown in top view. There should be no continuity.
5. Repeat Step 4 for contacts B and E and for contacts C and F.
6. Place test leads on contactor coil terminal as shown in left side view.
7. Check resistance.
8. If resistance is not approximately 390 (+/- 40) ohms, remove MOV and recheck coil resistance. If resistance is now approximately 390 (+/-40) ohms, replace MOV, otherwise replace contactor.
9. Reconnect all wires.



Figure 14

Idle Element Resistance Check (for units built before January 15, 2001)

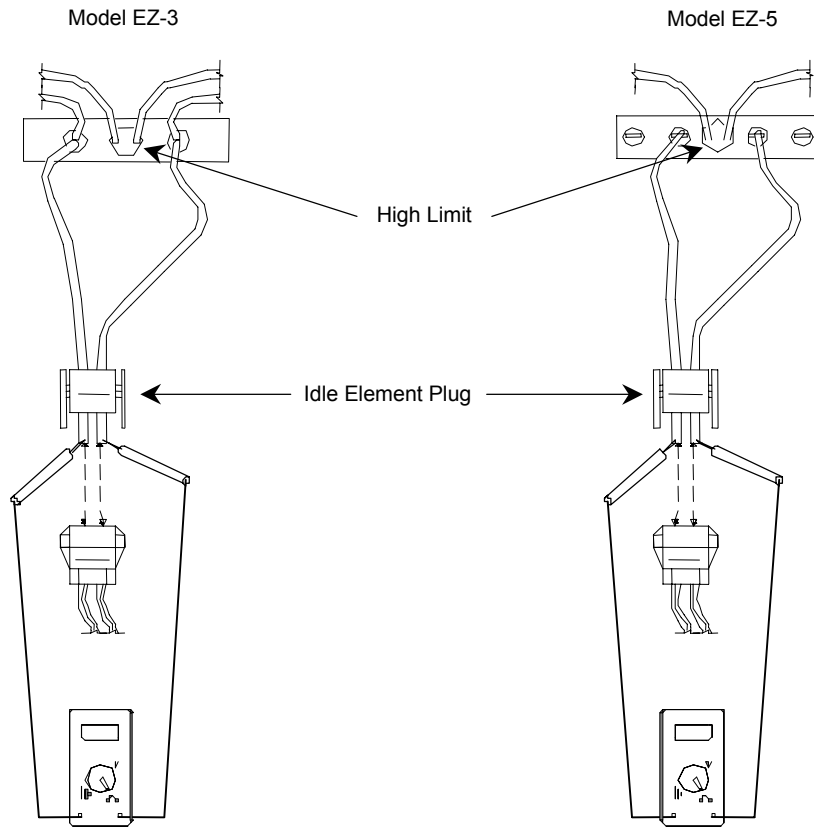

1. Disconnect power at circuit breaker.
2. Remove control panel.
3. Disconnect idle element plug (PL3).
4. Place test leads as shown above.
5. Check to see if resistance is within +/- 10% of values in the following table:

Voltage	Model EZ-3 Resistance (Ohms)	Model EZ-5 Resistance (Ohms)
208	115	87
220	129	97
240	154	115
380	385	289
415	459	344
480	614	461

6. Remove one test lead, place on ground, check for short circuit.

TROUBLESHOOTING

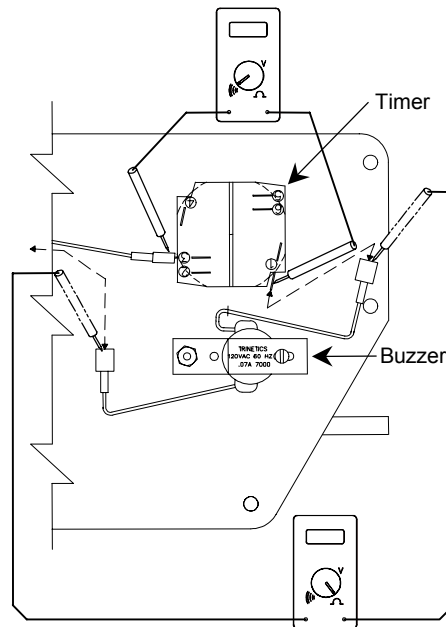

Figure 15

Timer and Buzzer Check

1. Disconnect power at circuit breaker.
2. Remove control panel.
3. Set timer for one minute and allow to time out. If timer does not run, then replace.
4. Remove buzzer lead wires from timer and terminal block position 6, as shown.
5. Place test leads between positions 1 and 3 on the timer.
6. Check for continuity. If no continuity, replace timer.
7. Place test leads in terminals of buzzer lead wires.
8. Check physical condition of buzzer.
9. Check that resistance is approximately 3.4Kohms. Otherwise, replace buzzer.



Figure 16

Door Switch Continuity Check (for units built before January 15, 2001)

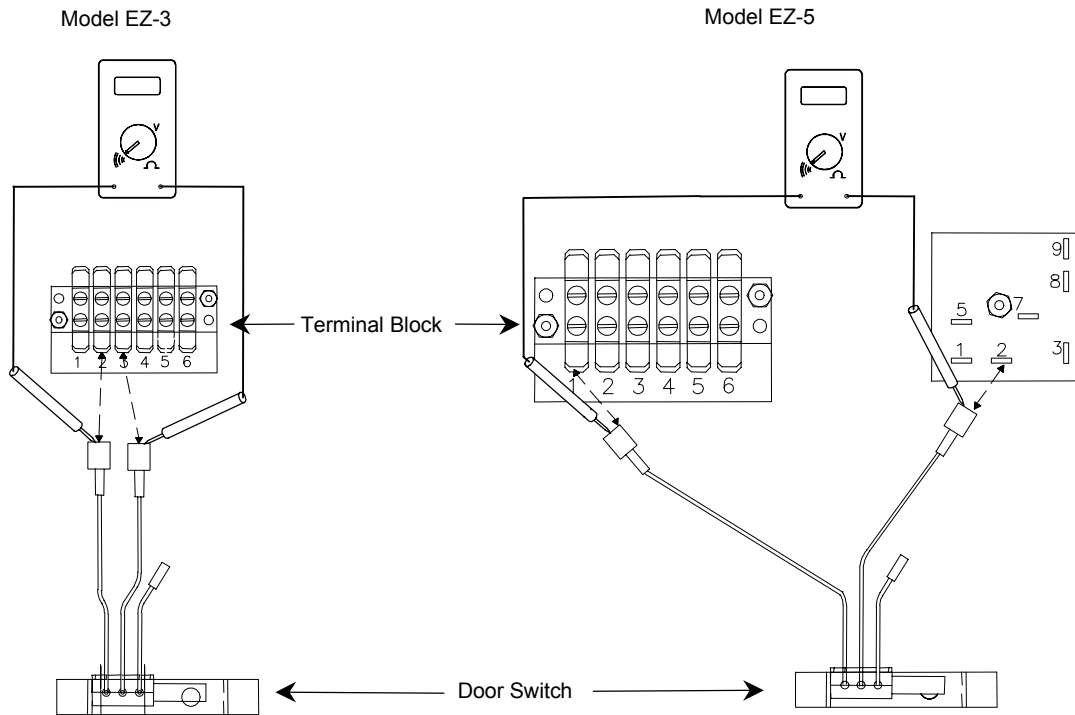

1. Disconnect power at circuit breaker.
2. Remove control panel.
3. Depress and release door switch actuator rod to make sure door switch is properly actuated.
4. EZ-3: Remove door switch lead wires from terminal block positions 2 and 3, or
EZ-5: Remove door switch lead wires from terminal block position 1 and terminal 2 of the controller.
5. Place test lead as shown inside the terminal connectors of the lead wires.
6. Check for continuity - (there should be NO continuity).
7. Depress door switch actuator rod and check for continuity - (there should be continuity).

TROUBLESHOOTING



Figure 17

Door Switch Continuity Check (for units built after January 15, 2001)

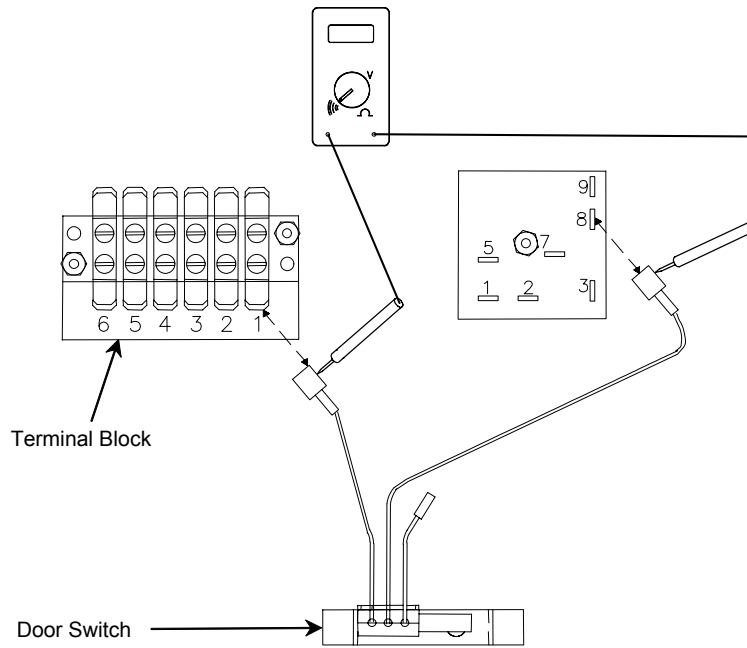

1. Disconnect power at circuit breaker.
2. Remove control panel.
3. Depress and release door switch actuator rod to make sure door switch is properly actuated.
4. Remove door switch lead wires from terminal block position 1 and terminal 8 of the controller.
5. Place test lead as shown inside the terminal connectors of the lead wires.
6. Check for continuity - (there should be NO continuity).
7. Depress door switch actuator rod and check for continuity - (there should be continuity).

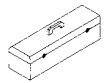
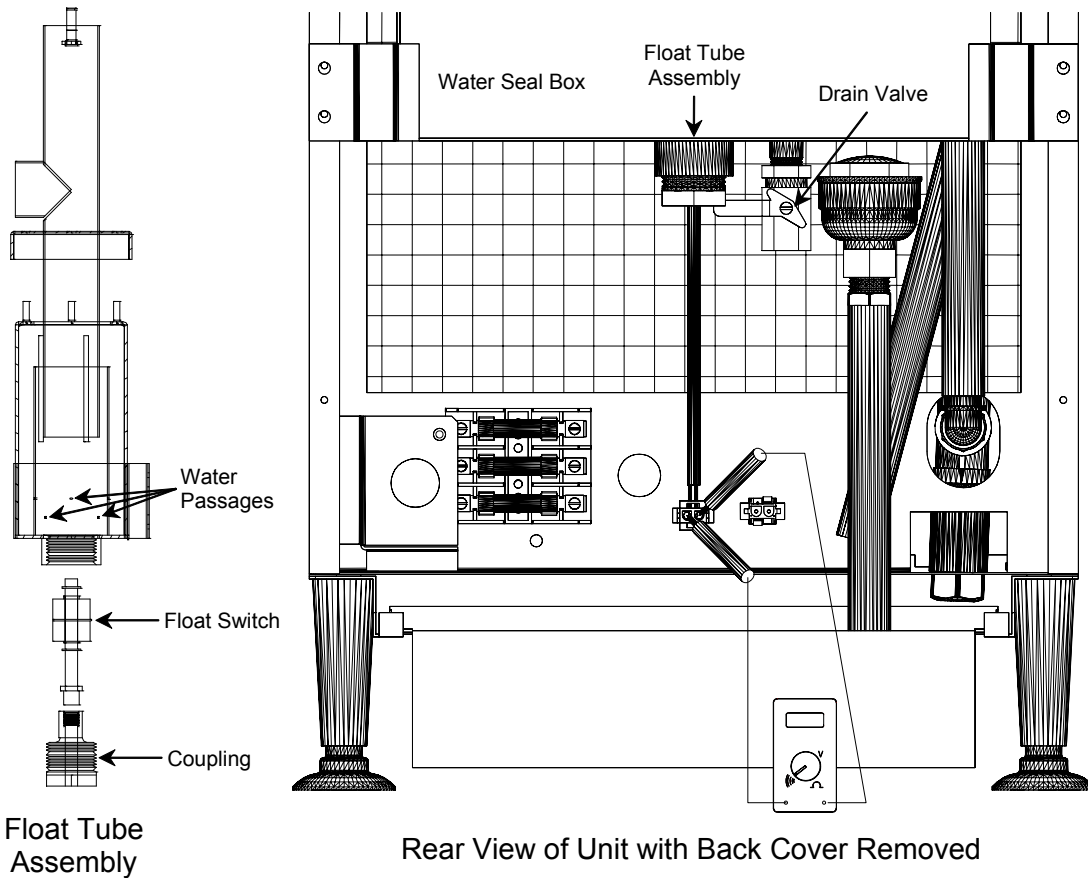

Figure 18

Float Switch Continuity Check



1. Disconnect power at circuit breaker.
2. Remove rear cover from unit.
3. Disconnect 2 pin float switch plug from mating plug on back of unit (PL2).
4. Drain water seal box by opening 3/8" drain valve on box.
5. Remove float switch from box by removing float switch fitting from coupling on box.
6. Make sure float travels freely along stem.
7. Place test leads in float switch connector as shown.
8. Hold float switch in same orientation as when installed.
9. Check continuity. There should not be continuity.
10. Flip float switch over.
11. Check for continuity. There should be continuity. Replace as necessary.
12. Check 0.060 water passages in float tube. Clean if necessary.

TROUBLESHOOTING

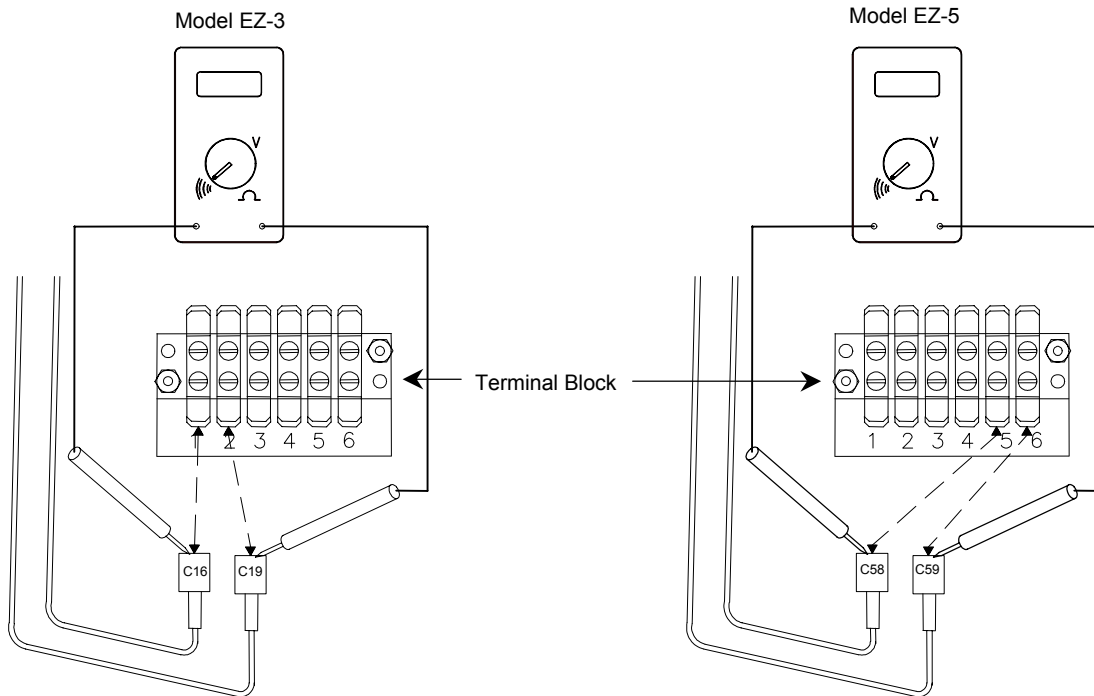

Figure 19

High Limit Continuity Check (for units built before January 15, 2001)

1. Turn unit off.
2. Wait for cavity bottom to cool to touch.
3. Disconnect power at circuit breaker.
4. Remove control panel without disconnecting plug.
5. EZ-3: Remove wires C16 and C19 from terminal block positions 1 and 2, as shown; or EZ-5: Remove wires C58 and C59 from terminal block positions 5 and 6, as shown.
6. EZ-3: Place test leads as shown inside the terminal connectors of wires C16 and C19, or EZ-5: Place test leads as shown inside the terminal connectors of wires C58 and C59.
7. Check for continuity.
8. If no continuity, disconnect each high limit switch individually and check for continuity. Replace switches that do not have continuity. (See Figure 14 on page 25 for typical high limit switch location.)
9. EZ-3: Reconnect wires C16 and C19; or EZ-5: Reconnect wires C58 and C59.
10. Reconnect power at circuit breaker.



Figure 20

High Limit Continuity Check (for units built after January 15, 2001)

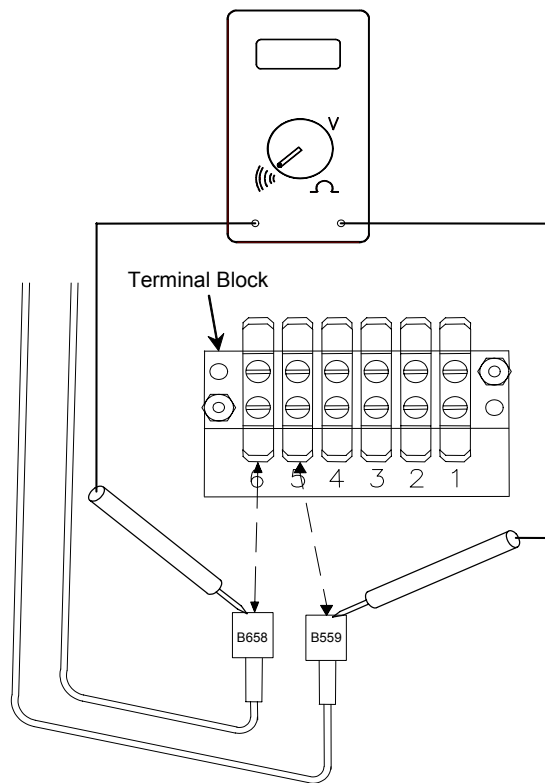

1. Turn unit off.
2. Wait for cavity bottom to cool to touch.
3. Disconnect power at circuit breaker.
4. Remove control panel without disconnecting plug.
5. Remove wires B559 and B658 from terminal block positions 5 and 6, as shown.
6. Place test leads as shown inside the terminal connectors of wires B658 and B559.
7. Check for continuity.
8. If no continuity, disconnect each high limit switch individually and check for continuity. Replace switches that do not have continuity. (See Figure 14 on page 25 for typical high limit switch location.)
9. Reconnect wires B658 and B559.
10. Reconnect power at circuit breaker.

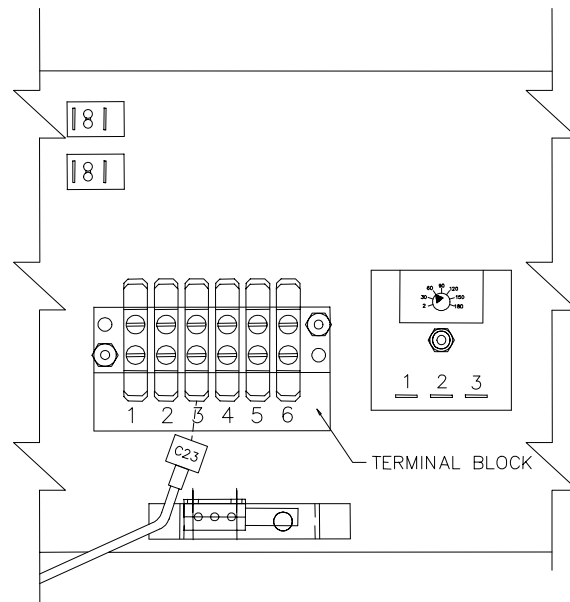

Figure 21

Time Delay Relay Check (for EZ-3 units built before January 15, 2001)

1. Disconnect power at circuit breaker.
2. Remove control panel, but leave plugged in.
3. Disconnect wire C23 from terminal block position 3.
4. Reconnect power.
5. Depress and hold door switch. Contactor should actuate and then deactuate in approximately 60 seconds.
6. If contactor fails to actuate or actuates but fails to deactuate, check potentiometer on top of time delay relay. Make sure potentiometer is seated properly on time delay relay terminal and make sure it is set to 60.
7. Depress door switch again. If contactor still fails to actuate and deactuate properly, replace time delay relay.



Figure 22

Controller Check (for all EZ-5 units and for EZ-3 units built after Jan. 15, 2001)

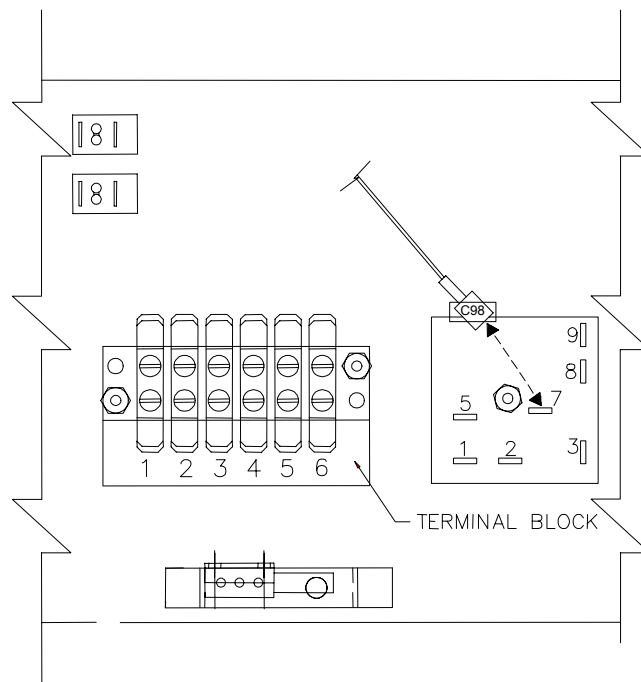

EZ STEAMER LOGIC CHART				
Step	Door Switch (SW2) #8	Float Switch (SW1) #7-#9	Contactors Heaters (Load 2) #5	Notes
1	Door Open	No Pressure, Up Position Switch Closed	Heaters Off	
2	Door Open to Close	No Pressure, Up Position Switch Closed	Heaters On for 60 Seconds, then Step 3 or 4	Even if float switch opens with pressure.
3	Door Closed	No Pressure, Up Position Switch Closed	Heaters On	
4	Door Closed	Pressurized, Down Position Switch Open	Heaters Off	
5	Normal Cycle Operation Door Closed	When Pressure Drops, Goes to Up Position, Switch Closes	Heaters On for 10 Seconds, then Step 3 or 4	Even if float switch opens with pressure.

1. Disconnect power at circuit breaker.
2. Remove control panel, but leave plugged in.
3. Disconnect wire C98 from controller.
4. Reconnect power.
5. Use a spacer to hold door switch in closed position. Contactor should actuate and then deactuate in less than 60 seconds.
6. If contactor fails to actuate (or actuates but fails to deactuate), replace controller.
7. With spacer still in place and door open, momentarily reconnect wire C98 and then disconnect.
8. Controller should actuate, then deactuate 10 seconds after C98 is disconnected.
9. If contactor fails to actuate (or actuates but fails to deactuate), replace controller.

TROUBLESHOOTING



Figure 23

Electric Schematic for 208-240 Volt 60 Hz or 220 Volt 50 Hz Model EZ-3 Units Built Before January 15, 2001

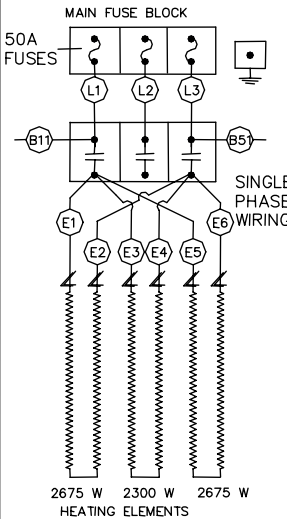
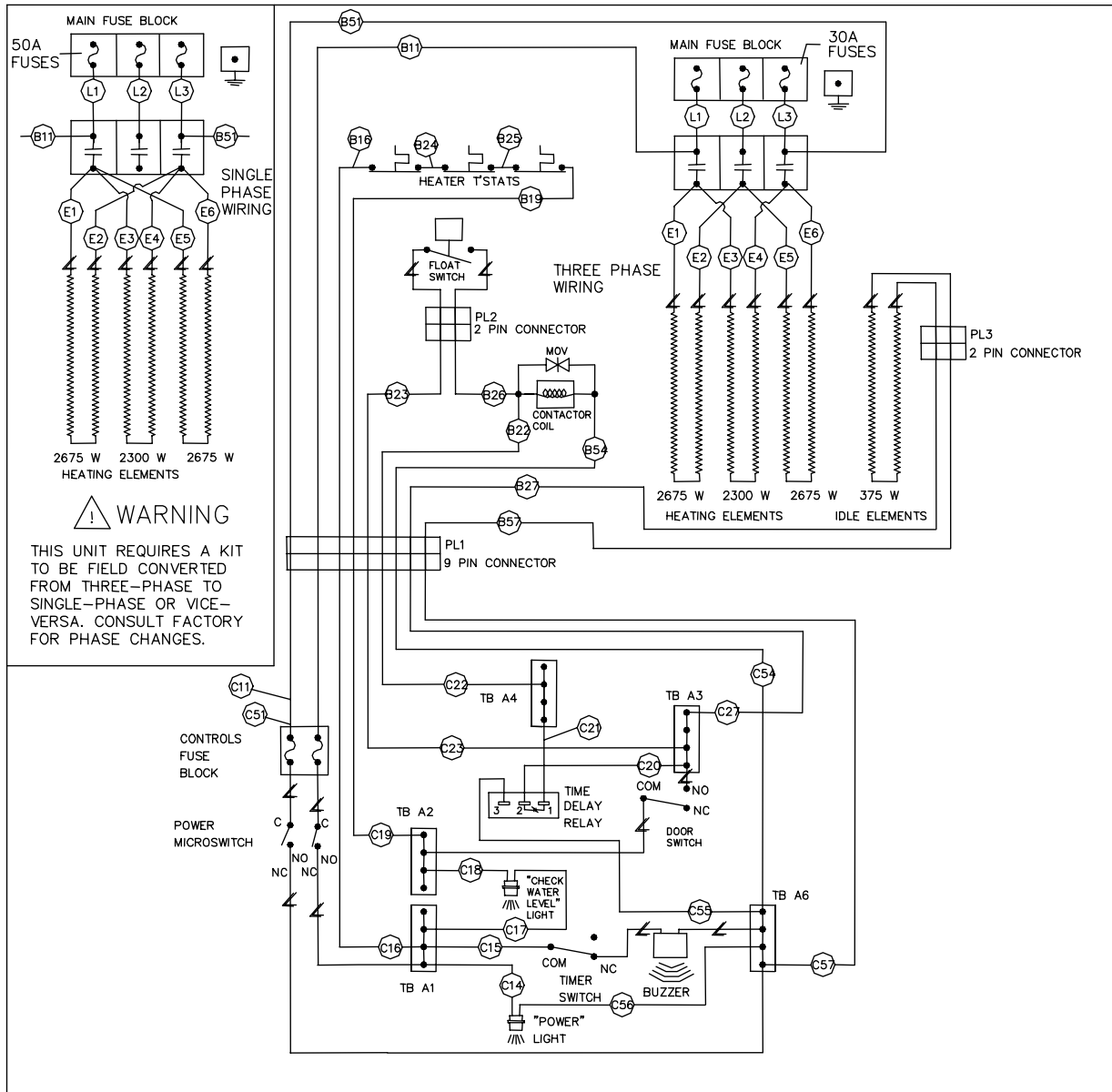

WARNING
 THIS UNIT REQUIRES A KIT TO BE FIELD CONVERTED FROM THREE-PHASE TO SINGLE-PHASE OR VICE-VERSA. CONSULT FACTORY FOR PHASE CHANGES.

- MULTI-PIN CONNECTOR
 - COMPONENT LEAD
 - TERMINAL BLOCK CONNECTIONS
 - WIRE NUMBERS
- JDC 01-98

VOLTAGE	208	240	220
PHASE	1	3	1 3
AMPERAGE	40	24	38 23

southbend WIRING DIAGRAM MODEL EZ-3 208-240V 60HZ / 220V 50HZ P/N 1178395 REV 3

TROUBLESHOOTING





Figure 24

Electric Schematic for 480 Volt Model EZ-3 Units Built Before January 15, 2001

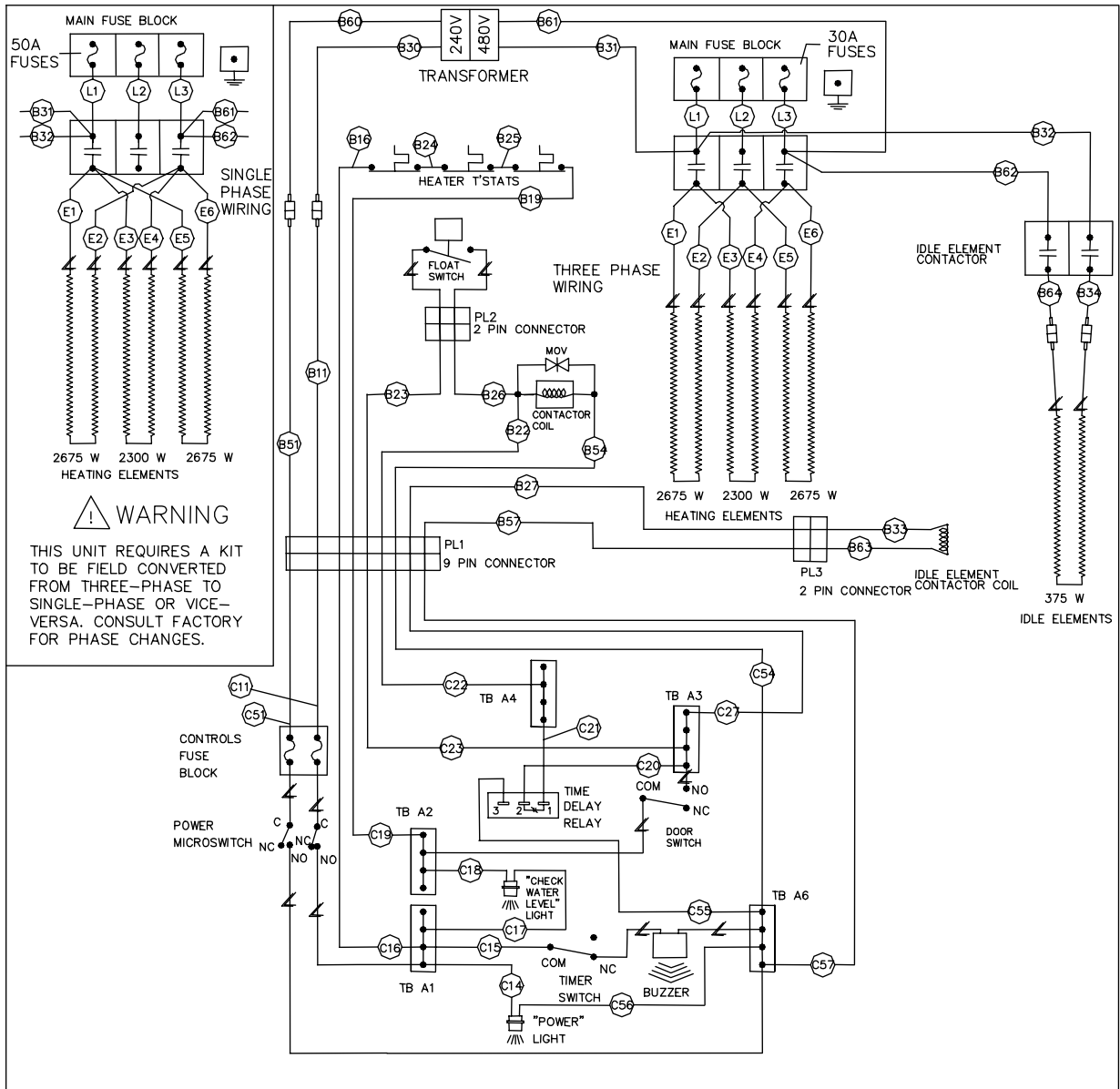

- MULTI-PIN CONNECTOR
 - PLUG CONNECTOR
 - COMPONENT LEAD
 - TERMINAL BLOCK CONNECTIONS
 - WIRE NUMBERS
- JDC 01-98

VOLTAGE	480	
PHASE	1	3
AMPERAGE	35	21



WIRING DIAGRAM MODEL EZ-3
480V 60HZ/50HZ

P/N
1178650

TROUBLESHOOTING



Figure 25

Electric Schematic for 208-240 Volt 60 Hz or 220 Volt 50 Hz Model EZ-5 Units Built Before January 15, 2001

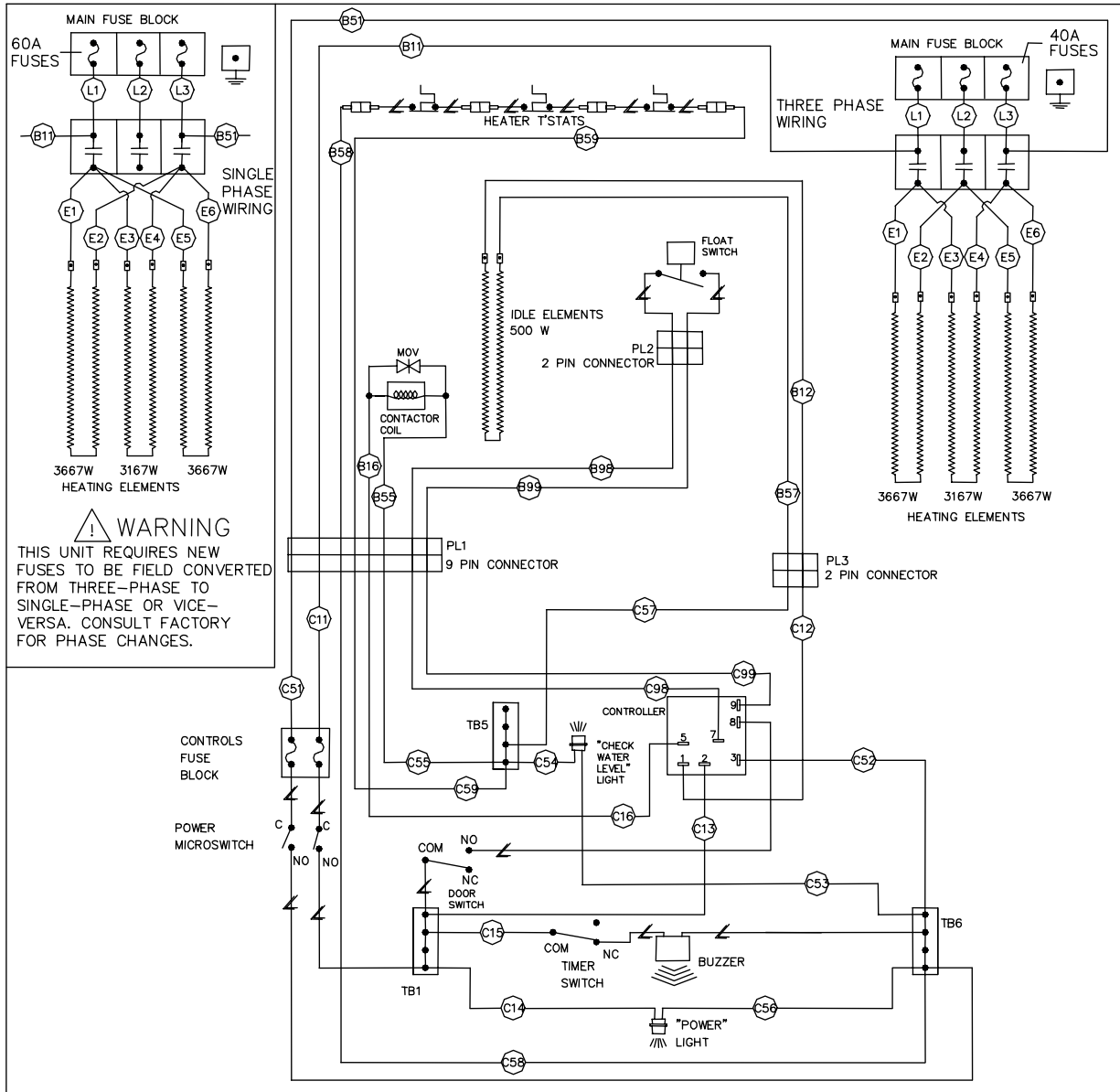

WARNING
 THIS UNIT REQUIRES NEW FUSES TO BE FIELD CONVERTED FROM THREE-PHASE TO SINGLE-PHASE OR VICE-VERSA. CONSULT FACTORY FOR PHASE CHANGES.

- MULTI-PIN CONNECTOR
- COMPONENT LEAD
- TERMINAL BLOCK CONNECTIONS
- WIRE NUMBERS
- PLUG CONNECTORS

VOLTAGE	208	240	220
PHASE	1	3	1 3
AMPERAGE	57	33	49 29 54 31

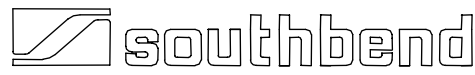

WIRING DIAGNOSTIC MODEL EZ-5
 208-240V 60HZ / 220V 50HZ
 P/N 1181037

TRUBLESHOOTING



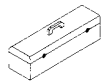
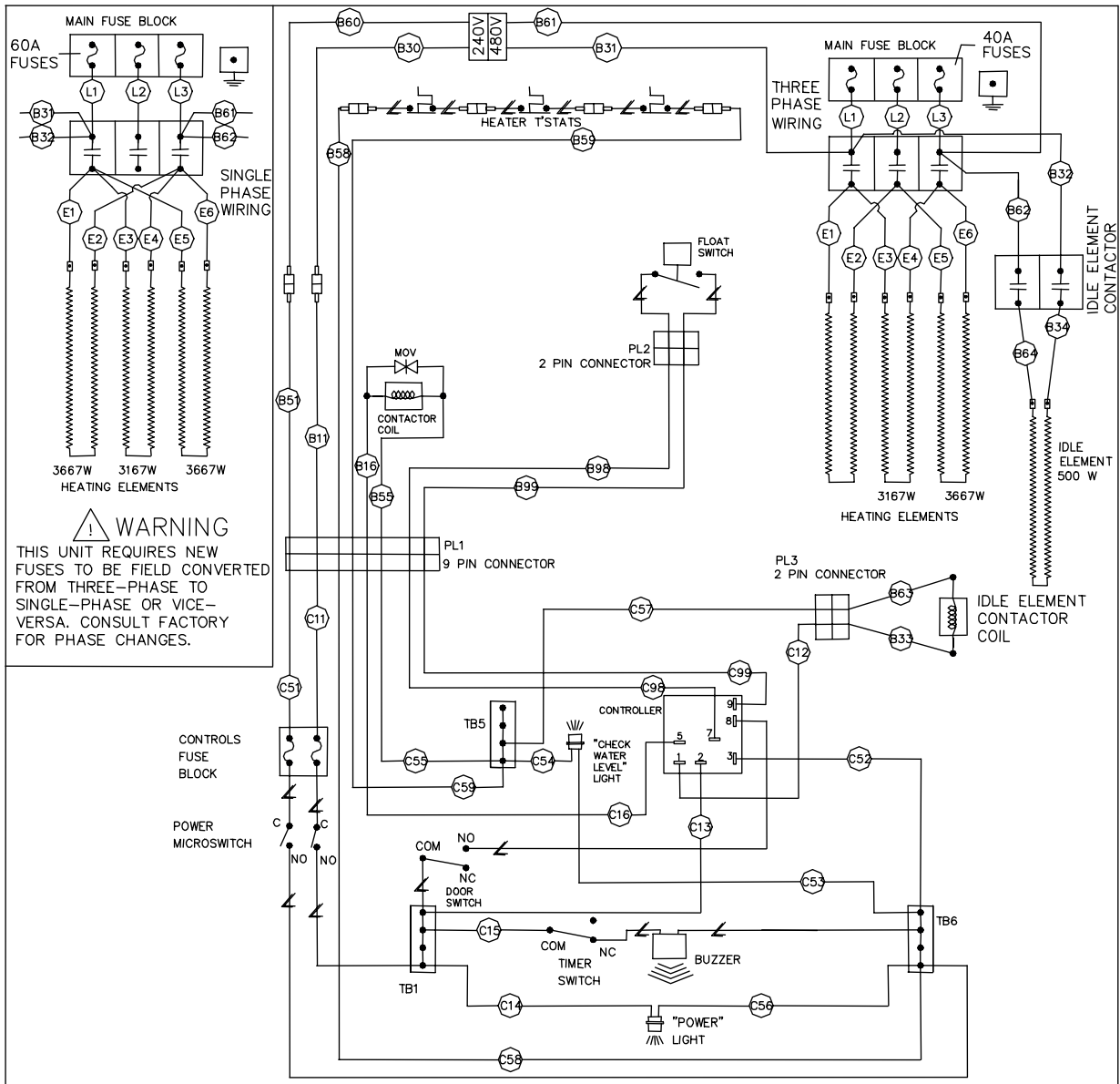

Figure 26

Electric Schematic for 480 Volt Model EZ-5 Units Built Before January 15, 2001



WARNING
 THIS UNIT REQUIRES NEW FUSES TO BE FIELD CONVERTED FROM THREE-PHASE TO SINGLE-PHASE OR VICE-VERSA. CONSULT FACTORY FOR PHASE CHANGES.

- MULTI-PIN CONNECTOR
- COMPONENT LEAD
- TERMINAL BLOCK CONNECTIONS
- WIRE NUMBERS
- PLUG CONNECTORS

VOLTAGE	480	
PHASE	1	3
AMPERAGE	25	15



WIRING DIAGNOSTIC MODEL EZ-5
 480V 60Hz/50Hz

P/N
 1181040

TROUBLESHOOTING



Figure 27

Electric Schematic for 208-240 Volt 60 Hz or 220 Volt 50 Hz Units (EZ-3 or EZ-5) Built After January 15, 2001

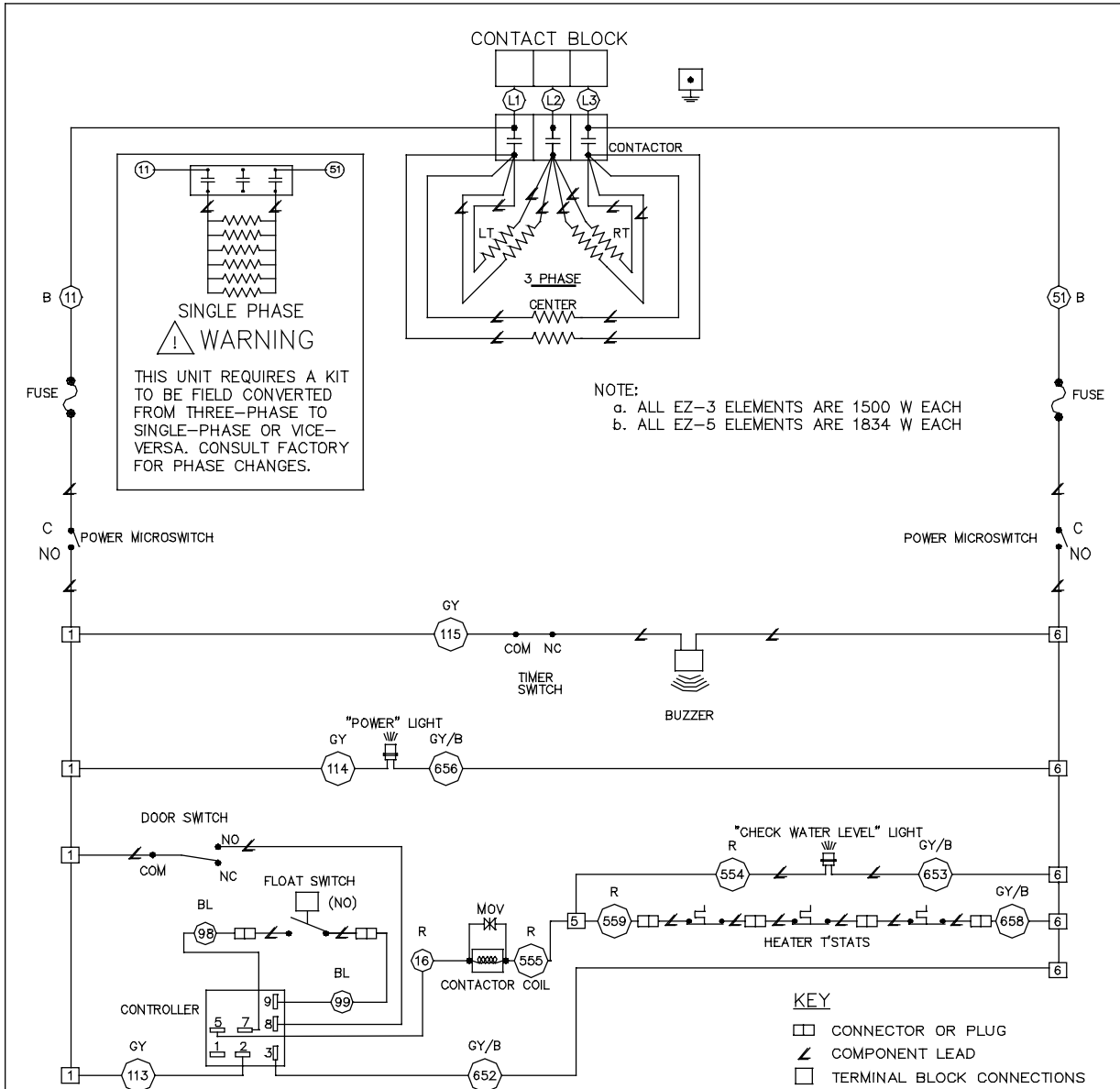

SINGLE PHASE WARNING

THIS UNIT REQUIRES A KIT TO BE FIELD CONVERTED FROM THREE-PHASE TO SINGLE-PHASE OR VICE-VERSA. CONSULT FACTORY FOR PHASE CHANGES.

NOTE:
 a. ALL EZ-3 ELEMENTS ARE 1500 W EACH
 b. ALL EZ-5 ELEMENTS ARE 1834 W EACH

- KEY**
- CONNECTOR OR PLUG
 - COMPONENT LEAD
 - TERMINAL BLOCK CONNECTIONS
 - WIRE NUMBERS

CONTROLLER: MODE OF OPERATION

FLOAT	DOOR	CONTACTOR
CLOSED *	CLOSED	CLOSED
OPEN	CLOSED	OPEN
X	OPEN *	OPEN
OPEN TO CLOSE	CLOSED	CLOSE FOR 10 SEC.
X	OPEN TO CLOSE	CLOSE FOR 60 SEC.

X = DONT CARE

* = IF SW1 REMAINS CLOSED FOR LONGER THAN 10 SEC. LOAD 2 WILL REMAIN CLOSED UNTIL IT OPENS. OR UNTIL SW2 OPENS.

** = IF SW2 REMAINS CLOSED FOR LONGER THAN 60 SEC. AND SW1 IS CLOSED, THEN LOAD 2 REMAINS CLOSED.

IF SW2 RE-OPENS BEFORE THE 60 S. THEN LOAD 2 IS TURNED OFF AND THE TIMER RESET.

EZ-3 SPECIFICATIONS						
VOLTAGE	208		240		220	
PHASE	1	3	1	3	1	3
AMPERAGE	46	27	40	24	44	26

EZ-5 SPECIFICATIONS						
VOLTAGE	208		240		220	
PHASE	1	3	1	3	1	3
AMPERAGE	57	33	49	29	54	31



WIRING DIAGRAM
208-240V 60HZ / 220V 50HZ
MODEL EZ-3 & EZ-5

P/N
1182133

TRUBLESHOOTING





Figure 28

Electric Schematic for 480 Volt Units (EZ-3 or EZ-5) Built After January 15, 2001

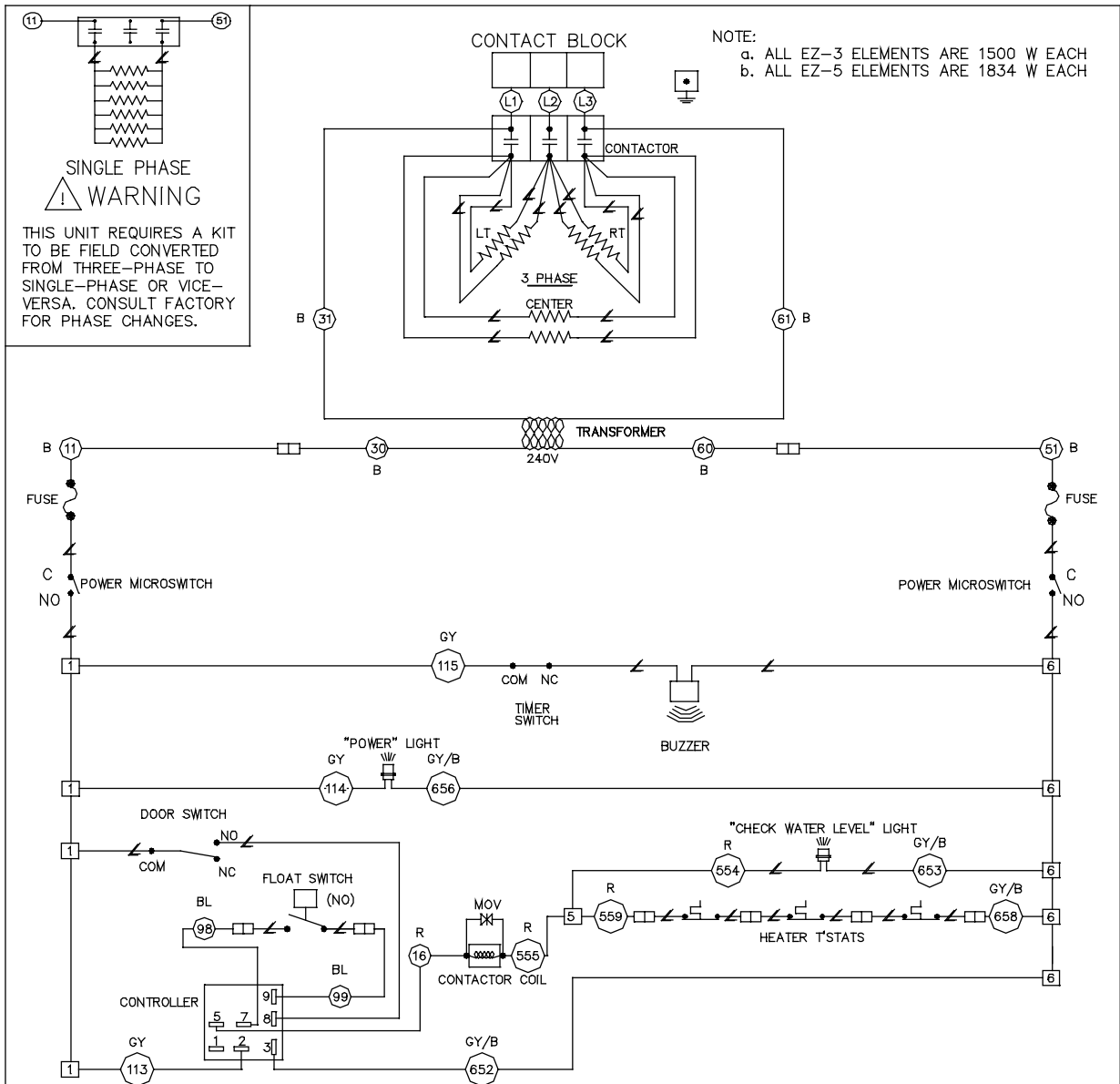

SINGLE PHASE WARNING
 THIS UNIT REQUIRES A KIT TO BE FIELD CONVERTED FROM THREE-PHASE TO SINGLE-PHASE OR VICE-VERSA. CONSULT FACTORY FOR PHASE CHANGES.

CONTROLLER: MODE OF OPERATION

	FLOAT	DOOR	CONTACTOR
	CLOSED *	CLOSED	CLOSED
	OPEN	CLOSED	OPEN
	X	OPEN *	OPEN
	OPEN TO CLOSE	CLOSED	CLOSE FOR 10 SEC.
	X	OPEN TO CLOSE	CLOSE FOR 60 SEC.

X = DONT CARE
 * = IF SW1 REMAINS CLOSED FOR LONGER THAN 10 SEC. LOAD 2 WILL REMAIN CLOSED UNTIL IT OPENS, OR UNTIL SW2 OPENS.
 ** = IF SW2 REMAINS CLOSED FOR LONGER THAN 60 SEC. AND SW1 IS CLOSED, THEN LOAD 2 REMAINS CLOSED.
 IF SW2 RE-OPENS BEFORE THE 60 S, THEN LOAD 2 IS TURNED OFF AND THE TIMER RESET.

- KEY**
- CONNECTOR OR PLUG
 - ∠ COMPONENT LEAD
 - TERMINAL BLOCK CONNECTIONS
 - WIRE NUMBERS

EZ-3 SPECIFICATION

VOLTAGE	480
PHASE	1 3
AMPERAGE	19 11

EZ-5 SPECIFICATION

VOLTAGE	480
PHASE	1 3
AMPERAGE	25 15



WIRING DIAGRAM
 480V
 MODEL EZ-3 & EZ-5

P/N
 1182134

TROUBLESHOOTING

PARTS

NOTICE

INSTALLATION OF OTHER THAN GENUINE SOUTHBEND PARTS WILL VOID THE WARRANTY ON THIS EQUIPMENT.

The serial plate with voltage, model, and serial information is located on the right side of the steamer cavity on the upper rear corner. On single units a second tag is located on the face of the door which will show only model and serial number. On tandem units, a second tag is on the right side of the right unit and the left side of the left unit.

Replacement parts may be ordered either through a Southbend Authorized Parts Distributor or a Southbend Authorized Service Agency.

When ordering parts, please supply the Model Number, Serial Number, Part Number, Description, Finish, and Electrical Characteristics as applicable.

For parts not listed, consult a Southbend Authorized Parts Distributor or Southbend Authorized Service Agency. Consult the Southbend Authorized Parts/Service Distributor list for the Authorized Parts supplier in your area.

Parts for Simple Steam Countertop Steamer		
EZ-3 Part Number	EZ-5 Part Number	Description - DOOR ASSOCIATED COMPONENTS
1178167	1181015	DOOR ASSEMBLY COMPLETE (With Latch Assembly)
1178171	1181018	DOOR INSULATION BLOCK FOR DOOR ASSEMBLY
1178096	1181010	GASKET FOR DOOR ASSEMBLY
1178169	1181017	OUTER PANEL FOR DOOR ASSEMBLY
1178105	1181016	INNER PANEL FOR DOOR ASSEMBLY
1178106	1181001	GASKET RETAINER PANEL FOR DOOR ASSEMBLY (for units built after January 27, 1998)
1178107	1181001	GASKET RETAINER PANEL FOR DOOR ASSEMBLY (for units built before January 27, 1998)
1183473	1183473	SEAL, GASKET REINFORCEMENT
PM-141	PM-141	PLUG BUTTON, 1/4 NYLON
1177317	1177317	LATCH ASSEMBLY, STEAMERS
1177079	1177079	CAST ARM FOR LATCH ASSEMBLY
1177078	1177078	CAST COVER PLATE ASSEMBLY
1177081	1177081	PIN, .250 DIA, SS FOR LATCH ASSEMBLY
1177086	1177086	CAST RETAINER ASSEMBLY
1177082	1177082	SPRING FOR LATCH ASSEMBLY
6600402	6600402	RING,RETAINING S.S. FOR LATCH ASSEMBLY
PH-423	PH-423	FLANGE BUSHING, 1/4ID BRO
PH-292	PH-292	NYLON WASHER FOR DOOR PIVOT
1332048-1	1132048-1	HINGE, LT DOOR
1332048-2	1132048-2	HINGE, RT DOOR
1332076	1332076	BLANK, DOOR HINGE
1177318	1177318	SHIM, CAST STRIKER

Parts for Simple Steam Countertop Steamer		
EZ-3 Part Number	EZ-5 Part Number	Description - HEATING ELEMENTS, HI LIMIT THERMOSTATS, AND CONTACTORS
*See Note		ELEMENT BLOCK, 220V,CENTER (1178354) (for units built before January 15, 2001)
1181500		HEATING ELEMENT HOUSING(Requires Qty of 1 for 1 element block exchange)
1181502		HEATING ELEMENT CARTRIDGE TYPE, 220V(Requires Qty of 2 for 1 element block exchange)
PN126		THERMOCOAT, 2 OZ TUBE(Requires Qty of 1 for 1 element block exchange)
*See Note		ELEMENT BLOCK, 220V,OUTER(1178360) (for units built before January 15, 2001)
1181500		HEATING ELEMENT HOUSING(Requires Qty of 1 for 1 element block exchange)
1181502		HEATING ELEMENT CARTRIDGE TYPE, 220V(Requires Qty of 2 for 1 element block exchange)
PN126		THERMOCOAT, 2 OZ TUBE(Requires Qty of 1 for 1 element block exchange)
1161525	1161525	CONTACTOR ,IDLE ELEMENT, 2-POLE,240V,30(for 460-480V units only)
1173448		CONTACTOR ,MAIN, 63A,240V COIL (for units built before January 15, 2001)
1181032	1181032	CONTACTOR ,MAIN, DP, 60 FLA(for units built after January 15, 2001)
1178355		ELEMENT BLOCK, 240V,CENTER (for units built before January 15, 2001)
1178361		ELEMENT BLOCK, 240V,OUTER (for units built before January 15, 2001)
1178358		ELEMENT BLOCK, 480V,CENTER (for units built before January 15, 2001)
1178364		ELEMENT BLOCK, 480V,OUTER (for units built before January 15, 2001)
1181500	1181500	ELEMENT HOUSING FOR CARTRIDGE ELEMENTS(for units built after January 15, 2001)
1178353		HEATING ELEMENT,208V, CENTER, DUAL COIL (for units built before January 15, 2001)
1178359		HEATING ELEMENT, 208V, OUTER, DUAL COIL, (for units built before January 15, 2001)
	1178560	HEATING ELEMENT, 208V, CENTER DUAL COIL, (for units built before January 15, 2001)
	1178561	HEATING ELEMENT, 220V, CENTER DUAL COIL, (for units built before January 15, 2001)
	1178565	HEATING ELEMENT, 480V, CENTER DUAL COIL, (for units built before January 15, 2001)
	1178562	HEATING ELEMENT, 240V, CENTER DUAL CO (for units built before January 15, 2001)
	1178554	HEATING ELEMENT, 208V, OUTER (for units built before January 15, 2001)
	1178555	HEATING ELEMENT, 220V, OUTER (for units built before January 15, 2001)
	1178556	HEATING ELEMENT, 240V, OUTER (for units built before January 15, 2001)
	1178559	HEATING ELEMENT, 480V, OUTER (for units built before January 15, 2001)
1181501	1181771	HEATING ELEMENT CARTRIDGE TYPE, 208V (for units built after January 15, 2001)
1181502	1181772	HEATING ELEMENT CARTRIDGE TYPE, 220V (for units built after January 15, 2001)
1181503	1181773	HEATING ELEMENT CARTRIDGE TYPE, 240V (for units built after January 15, 2001)
1181504	1181774	HEATING ELEMENT CARTRIDGE TYPE, 480V (for units built after January 15, 2001)
	1181039	LEAD, ELEMENT EZ-5(for units built before January 15, 2001)
1178373	1178373	SHIELD,HEAT TRANSFER(for units built before January 15, 2001)
1181752	1181752	SHIELD,HEAT TRANSFER(for units built before January 15, 2001)
1173374	1173374	THERMOCOAT
	1181013	THERMOSTAT ASSEMBLY CENTER, F/F(for units built before January 25, 2001)
	1181012	THERMOSTAT ASSEMBLY OUTER, M/M(for units built before January 25, 2001)
1174302		THERMOSTAT, ELEMENT, 2001 (for units built before January 25, 2001)
1181011	1181011	THERMOSTAT 200 DEG C (for units built after January 15, 2001)
1178367	1178367	METAL OXIDE VARISTOR

*Use quantity listed directly below. Once block & elements exchanged for cartridge type heater, defective heater only needs replacing.

MODEL EZ-3 & EZ-5 COUNTERTOP STEAMERS

Parts for Simple Steam Countertop Steamer		
EZ-3 Part Number	EZ-5 Part Number	Description - FUSES, WIRE HARNESSSES, AND TRANSFORMER
1178389		BUSSMAN FUSE BLOCK,30A (for units built before July 1, 2002)
1178494	1178494	BUSSMAN FUSE BLOCK,60A 48 (for units built before July 1, 2002)
1179962	1179962	COVER,REMOVABLE BUSS(for units built before July 1, 2002)
1178390		FUSE, 30 AMP (for units built before July 1, 2002)
	1181024	FUSE, 35 AMP (for units built before July 1, 2002)
1178495		FUSE, 50 AMP, CLASS G (for units built before July 1, 2002)
	1181026	FUSE, 60 AMP (for units built before July 1, 2002)
1181041	1181041	HARNESS, WIRE (for all EZ-5 units and for EZ-3 units built after January 15, 2001)
1177361	1177361	MAIN TERMINAL BLOCK(for units built before July 1, 2002)
1178374	1178374	MAIN POWER LEADS(Contactor to TB) 30"
1176388	1176388	TRANSFORMER, 480 TO 240,7
1181041	1181041	WIRE HARNESS (for units built after January 15, 2001)
1178652	1181043	WIRE HARNESS SUPPL., 480V
1178394		WIRE HARNESS W/DISC TSTAT (for units built before January 15, 2001)
Description - FLOAT TANK COMPONENTS		
1178266	1178266	BOX WELD ASM.,REAR(for units built before March 2, 2001)
1178266	1181051	BOX WELD ASM.,REAR(for units built after March 2, 2001)
1178261	1178261	TUBE & BOX TOP W/A
1181596	1181596	GASKET, TANK TOP
1178422	1178422	FITTING,FLOAT SWITCH (for units built before September 29, 2000)
1181618	1181618	FITTING,FLOAT SWITCH(long) (for units built between September 29, 2000 & July 1, 2002)
1183413	1183413	FITTING,FLOAT SWITCH(short) (for units built before July 1, 2002)
1178340	1178340	FLOAT SWITCH(for units built before September 29, 2000)
PE-193	PE-193	FLOAT SWITCH(for units built between September 29, 2000 & January 15, 2001)
PE-193	1174924	FLOAT SWITCH(for units built between January 15, 2001 & April 13, 2001)
PE-193	PE-193	FLOAT SWITCH (for units built after April 13, 2001)
Description - WATER VALVES, LINES, AND FITTINGS		
1178526	1178526	ELBOW 90DEGREE 1"NPT
1178332	1178332	FITTING,3/4 HOSE ID X 1/2
1178423		FITTING,3/4" KYNAR HOSE,E
1181028	1181028	HOSE, PLASTIC 1"OD, 3/4"ID, WITH MOLDED 90 DEGREE BEND
1178483		HOSE, 1 1/2"ID,SILCONE
1178385	1178385	HOSE, CAVITY TO BOX TOP 1-1/2"
1178386	1178386	HOSE,3/4" ID SILCONE
1178368	1178368	HOSE CLAMP
1178379	1178379	STEAM TRAP, BRASS 90 DEGREE
1178376	1178376	TUBE, VALVE ACTUATOR
1178425	1178425	VALVE, 1/2" DRAIN,MODIFIED(Used with Valve Lever Weldment 1178388)
1178444	1178444	VALVE, 3/8" BALL,NSF/FDA(Used to drain float box)

Parts for Simple Steam Countertop Steamer		
EZ-3 Part Number	EZ-5 Part Number	Description - INSULATION , EXTERIOR PANELS, RACK GUIDES
1178370	1181022	INSULATION, CAVITY
1178369	1181021	INSULATION, BACK PANEL
1178371	1178371	INSULATION, BOTTOM(for units before January 15, 2001)
1181583	1181583	INSULATION, BOTTOM(for units after January 15, 2001)
1178418	1178418	INSULATION, FRONT CAVITY(for units before January 15, 2001)
1181753	1181753	INSULATION, FRONT CAVITY(for units after January 15, 2001)
1178265	1178265	COVER, BOTTOM
1178365		COVER, REAR STEAMER(for units built before July 28, 1998)
1178527	1181000	COVER, REAR STEAMER(for units built between July 28, 1998 & September 1, 2001)
1182536	1182537	COVER, REAR STEAMER(for units after September 1, 2001)
1178255	1181009	COVER,EXTERIOR
1178656	1178657	COVER,EXTERIOR,STACKED
1178227		GASKET, SIDE PANEL(for units before April 23, 1999)
1178234		SIDE PANEL,SIMPLE STEAM(for units before October 26, 2000)
1178439	1178439	TROUGH SCREEN ASM.
1178324	1178324	WATER TROUGH W/A
1178113	1181045	SLIDE RACK, 3 PAN STEAMER(for units before October 1, 1999)
1178644		SLIDE RACK, 5 POS. 3 PAN(for units before February 6, 1999)
1178663		RIGHT SLIDE RACK, 3 PAN STEAMER(for units after October 1, 1999)
1178668		LEFT SLIDE RACK, 3 PAN STEAMER(for units after October 1, 1999)
	1178679	RIGHT SLIDE RACK, 5 PAN STEAMER(for units after October 1, 1999)
	1178678	LEFT SLIDE RACK, 5 PAN STEAMER(for units after October 1, 1999)
1333041	1333041	RACK MOUNTING STUDS,1/4-2
Description - STACKING KIT AND ACCESSORIES		
1178525	1178525	BRACKET, VENT TUBE
1178524	1178524	COVER W/A, DRAIN BOX
1178552	1178552	COVER W/A, DRAIN
1178522	1178522	DRAIN BOX WELD ASM.
1333045		DRAIN VENT TUBE (AIR VEN
1178526		ELBOW, 90 DEG. 1"NPT FEM,
	1178670	ELBOW, 90 DEG, STR. 1/2"(for units before January 15, 2001)
	1178685	HOSE, OVERFLOW, 28"
4440478	4440480	KIT, DRAIN BOXES,STACK
1172951	1172951	SLEEVE, RUBBER 1 1/4"ID X
1178654	1178654	STAND W/DRAIN, EZ
1178655	1178655	STAND, EZ
1176878		VENT PIPE, 1" NIPPLE
	1178683	VENT PIPE, 1" X 24.375"
1178442	1178442	COVER ASM.,POOL
1176797		DESCALER, 3.5OZ PKG (100G)
1178410	1178410	DRAIN PAN WELD ASM.(Under Steamer Compartment)
1180953	1180953	HANGER,HOSE
1178485	1178485	LEG,4" S/S, EZ (FRONT)
1178486	1178486	LEG,4" S/S,EZ (REAR)
1178344	1178344	PAN Z-BRACKET,LEFT
1178345	1178345	PAN Z-BRACKET,RIGHT
1178684	1178684	POT FILLER

MODEL EZ-3 and EZ-5 SIMPLE STEAM COUNTERTOP STEAMERS



A product with the Southbend name incorporates the best in durability and low maintenance. We all recognize, however, that replacement parts and occasional professional service may be necessary to extend the useful life of this unit. When service is needed, contact a Southbend Authorized Service Agency, or your dealer. To avoid confusion, always refer to the model number, serial number, and type of your unit.



Southbend
1100 Old Honeycutt Road, Fuquay-Varina, NC 27526
www.southbendnc.com

Free Manuals Download Website

<http://myh66.com>

<http://usermanuals.us>

<http://www.somanuals.com>

<http://www.4manuals.cc>

<http://www.manual-lib.com>

<http://www.404manual.com>

<http://www.luxmanual.com>

<http://aubethermostatmanual.com>

Golf course search by state

<http://golfingnear.com>

Email search by domain

<http://emailbydomain.com>

Auto manuals search

<http://auto.somanuals.com>

TV manuals search

<http://tv.somanuals.com>