

Installation and Maintenance Instructions for Drying Tumblers

30 Pound (13 Kg) Capacity

JCB30CE, JCB30CG, JCB30CSH, JCB30CSL, JCB30WE, JCB30XG,
SCB30CE, SCB30CG, SCB30CSH, SCB30CSL, SCB30WE and SCB30XG

50 Pound (22 Kg) Capacity

JC50CE, JC50CG, JC50CSH, JC50EG, JCB50CE, JCB50CG, JCB50CSH,
JCB50EG, SC50CE, SC50CG, SC50CSH, SC50EG, SCB50CE, SCB50CG,
SCB50CSH and SCB50EG

75 Pound (34 Kg) Capacity

JC75CE, JC75CG, JC75CSH, JCB75CE, JCB75CG, JCB75CSH, SC75CE,
SC75CG, SC75CSH, SCB75CE, SCB75CG and SCB75CSH

ATTENTION: Please read the enclosed instructions before using the machine.

KEEP THESE INSTRUCTIONS FOR FUTURE REFERENCE.
(If this tumbler changes ownership, be sure this manual
accompanies the tumbler).

**A copy of the operating instruction must remain with the tumbler after
installation.**

To locate the servicer nearest you, call (414) 748-3121.

**Part No. M412616
1/95**

**Manufactured By:
Speed Queen Company
P.O. Box 990
Ripon, WI 54971-0990
U.S.A.**

Distributed By:

WARNINGS AND LABELS

▲WARNING

FAILURE TO INSTALL, MAINTAIN, AND/OR OPERATE THIS MACHINE ACCORDING TO MANUFACTURER'S INSTRUCTIONS MAY RESULT IN CONDITIONS WHICH CAN PRODUCE SERIOUS INJURY, DEATH AND/OR PROPERTY DAMAGE.

NOTE: The WARNING and IMPORTANT instructions appearing in this manual are not meant to cover all possible conditions and situations that may occur. It must be understood that common sense, caution and carefulness are factors which CANNOT be built into this tumbler. These factors MUST BE supplied by the person(s) installing, maintaining or operating the tumbler.

Always contact your dealer, distributor, service agent or the manufacturer on any problems or conditions you do not understand.

▲WARNING

To reduce the risk of fire, electrical shock, serious injury or death to persons do not operate the tumbler if it does not perform according to these instructions. Immediately disconnect electrical service, shut off gas supply and contact an authorized service representative. Service and repairs are to be performed by authorized service representatives only.

▲WARNING

To reduce the risk of fire, electrical shock, serious injury or death to persons when using the tumbler unit, follow these basic precautions:

- **Read all instructions before using tumbler.**
- **DO NOT tamper with controls.**
- **DO NOT bypass any safety devices.**
- **Always follow the fabric care instructions supplied by the garment manufacturer.**
- **Remove laundry immediately after the tumbler stops.**
- **DO NOT reach into tumbler if cylinder is revolving.**

▲WARNING

To avoid creating any flammable vapors which may explode, ignite or cause corrosive damage, DO NOT dry the following materials:

- **Articles that have been cleaned in, soaked in, washed in or spotted with gasoline, dry cleaning solvents or other flammable/explosive substances.**
- **Plastics or articles containing foam rubber or similarly textured rubberlike materials.**
- **Articles that have traces of flammable substances like cooking oil, machine, oil, flammable chemicals or thinner.**
- **Articles containing wax or cleaning chemicals.**
- **Fiberglass curtains or draperies (unless the label says it can be done).**

▲WARNING

To reduce the risk of serious injury, install lockable door(s) to prevent public access to rear of tumblers.

⚠ WARNING

To reduce the risk of fire, electric shock, serious injury or death to persons when using your dryer, follow these basic precautions:

1. Do not allow children to play on or in the tumbler. Close supervision of children is necessary when the tumbler is used near children. This is a safety rule for all appliances.
2. Before the tumbler is removed from service or discarded, remove the door to the drying compartment.
3. Do not install or store the tumbler where it will be exposed to water and/or weather.
4. Failure to install, maintain, and/or operate this machine according to the manufacturer's instructions may result in conditions which can produce serious injury, death and/or property damage.
5. Run tumbler with a load before putting tumbler into service.
6. Always disconnect the electrical power to the tumbler before servicing. Disconnect power by shutting off appropriate circuit breaker or fuse and by turning off the disconnect switch located on the rear of the tumbler.
7. All manually operated models are factory-equipped with an emergency stop button located on the front panel. If the emergency stop function is desired on coin-operated models, an external emergency stop switch may be installed as specified on the machine wiring diagram.

NOTE: Activation of the emergency stop switch stops all machine control circuit functions, but does not remove all electrical power from machine.

NOTE: This drying tumbler produces sound rated at 65 dbA.

The following warning labels will be found on the drying tumbler:



A clothes dryer produces combustible lint. TUMBLER MUST BE EXHAUSTED OUTDOORS.



Do not touch rotating parts.



Do not touch surface until it has cooled.



WARNING!



Do not operate without guards in place.



Disconnect electrical power before servicing.



To reduce risk of accumulating unsafe concentrations of combustion gases, tumbler MUST BE EXHAUSTED OUTDOORS.

⚠ WARNING

- **DO NOT** put articles soiled with flammable liquids or flammable cleaning solvents in dryer.
- **DO NOT** store or use flammable liquids near this appliance.
- **DO NOT** spray or store aerosols in the vicinity of this appliance.
- Various chemicals used in laundries contain chlorine (some dry cleaning fluids, aerosols, bleaches). When decomposed in a flame, these materials may rapidly corrode and destroy this appliance.
- Dryer must be exhausted outdoors, and area around dryer must be free of lint because dryer produces combustible lint.
- **DO NOT** dry articles containing foam rubber, plastic or similarly textured rubberlike materials.
- Use for drying water washed fabrics only.
- **DO NOT** put articles soiled with vegetable or cooking oil in dryer as these oils may not be removed during washing. Due to the remaining oil, the fabric may catch on fire by itself.
- **DO NOT** reach into the dryer until all moving parts have stopped.
- **DO NOT** let children play in the dryer.

M412092

TABLE OF CONTENTS

NAMEPLATE LOCATION 4
REPLACEMENT PARTS INFORMATION 4

SECTION I ROUGHING-IN DIMENSIONS AND SPECIFICATIONS

30 pound (13 kg) Narrow Cabinet:
 Gas Tumblers 5
 Electric Tumblers 7

30 Pound (13 kg):
 Gas Tumblers 9
 Electric Tumblers 11
 Steam Tumblers 13

50 Pound (22 kg):
 Gas Non-reversing Tumblers 15
 Gas and Steam Reversing Tumblers 17
 Electric Non-reversing Tumblers 18
 Electric Reversing Tumblers 20
 Steam Non-reversing Tumblers 21

75 Pound (34 kg):
 Gas Non-reversing Tumblers 23
 Gas and Steam Reversing Tumblers 24
 Electric Non-reversing Tumblers 26
 Electric Reversing Tumblers 27
 Steam Non-reversing Tumblers 29

SECTION II INSTALLATION INSTRUCTIONS

Receiving Inspection 31
Materials Required (Obtain Locally) 31
Facilities Required:
 Floor 31
 Layout 31
 Venting 31
 Make-Up Air 32

Electrical Requirements:
 30 Pound (13 kg) Narrow Cabinet Tumblers 35
 30 Pound (13 kg) Tumblers 36
 50 Pound (22 kg) Tumblers 38
 75 Pound (34 kg) Tumblers 40
Electrical Connections 41
Positioning the Drying Tumbler 42
Leveling the Drying Tumbler 42
Gas Requirements (Gas Drying Tumblers) 42
 Example of Gas Loop Piping 43
 Example of Gas Supply Piping 43
Gas Connections (Gas Drying Tumblers) 45
Drying Tumbler Enclosure Construction 46
Steam Requirements (Steam Drying Tumblers) 47
Steam Connections (Steam Drying Tumblers) 47
Lighting and Shutting Down Gas Ignition System .. 49
Accessory Timing Cam Installation 50
Preliminary Operating Checks 51
Final Operating Checks 51

SECTION III ADJUSTMENTS

Main Gas Burner Air Shutter (All Gas Models) 53
Air Flow Switch (Gas and Electric Models) 53
Loading Door Switch 55
Cylinder Door Strike 55
Drive V-Belt 56

SECTION IV PREVENTIVE MAINTENANCE INSTRUCTIONS

Daily 57
Monthly 57
Quarterly 58
Biannually 58
Maintenance Check Chart 59

SECTION V DECOMMISSIONING INSTRUCTIONS

Decommissioning Instructions 61

NAMEPLATE LOCATION

IMPORTANT
When writing for information on any tumbler, be sure to mention model and serial numbers. The model and serial numbers will be found on the nameplate as shown on rear of tumbler or underneath the door hinge.

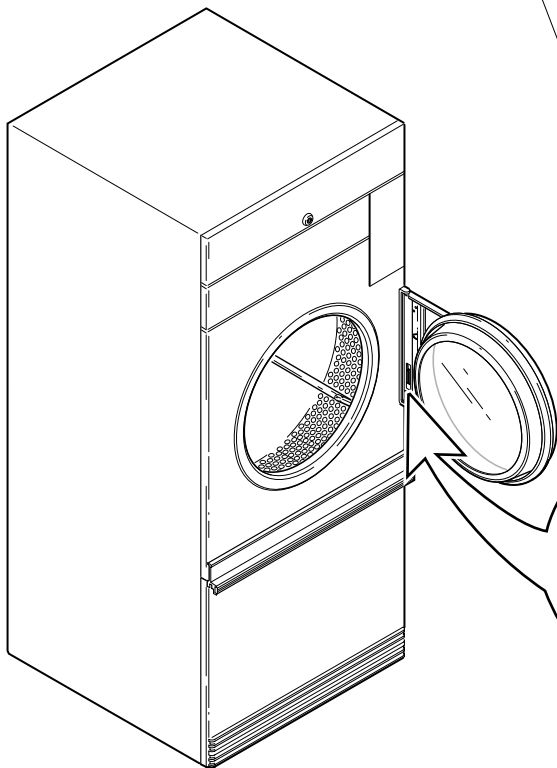
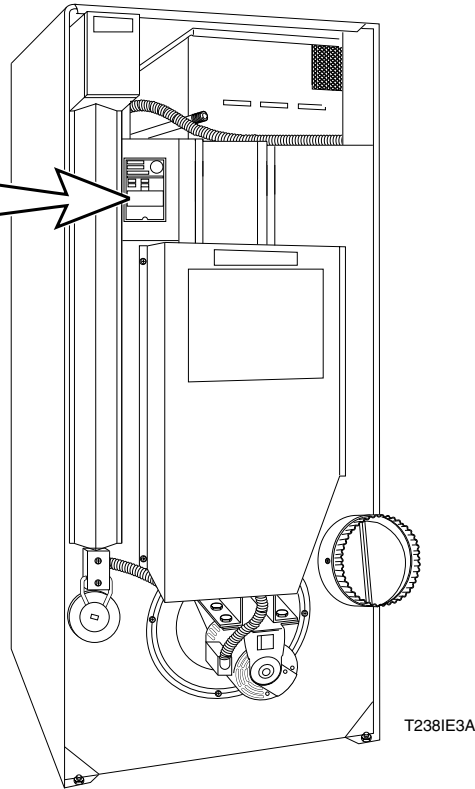

IMPORTANT
When writing for information on any tumbler, be sure to mention model and serial numbers. The model and serial numbers will be found on the nameplate as shown on the rear of tumbler or underneath the door hinge.

REPLACEMENT PARTS INFORMATION

If replacement parts are required, contact the source from whom you purchased your tumbler or, contact the Ripon Service Parts Center, P.O. Box 990, Ripon, Wisconsin 54971-0990, for the name and address of the nearest authorized parts distributor.

SECTION I

Roughing-In Dimensions and Specifications 30 Pound (13 kg) Narrow Cabinet Gas Tumbler

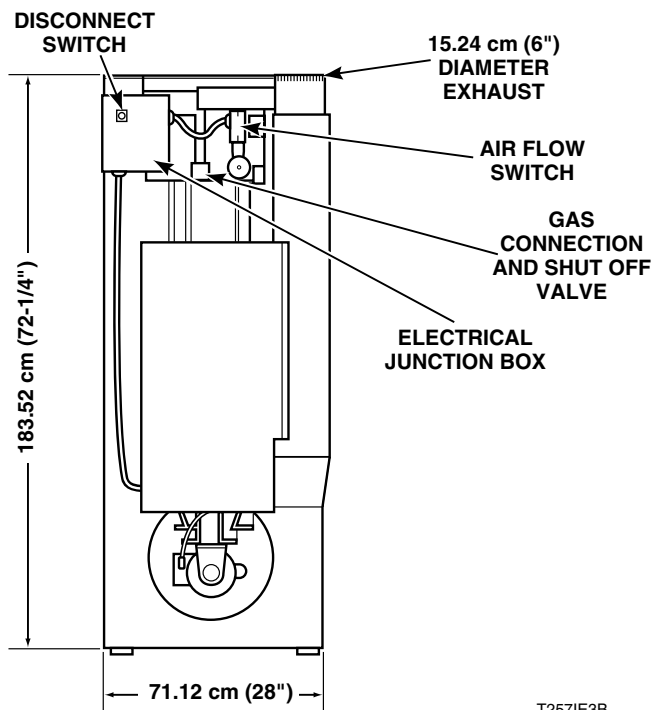
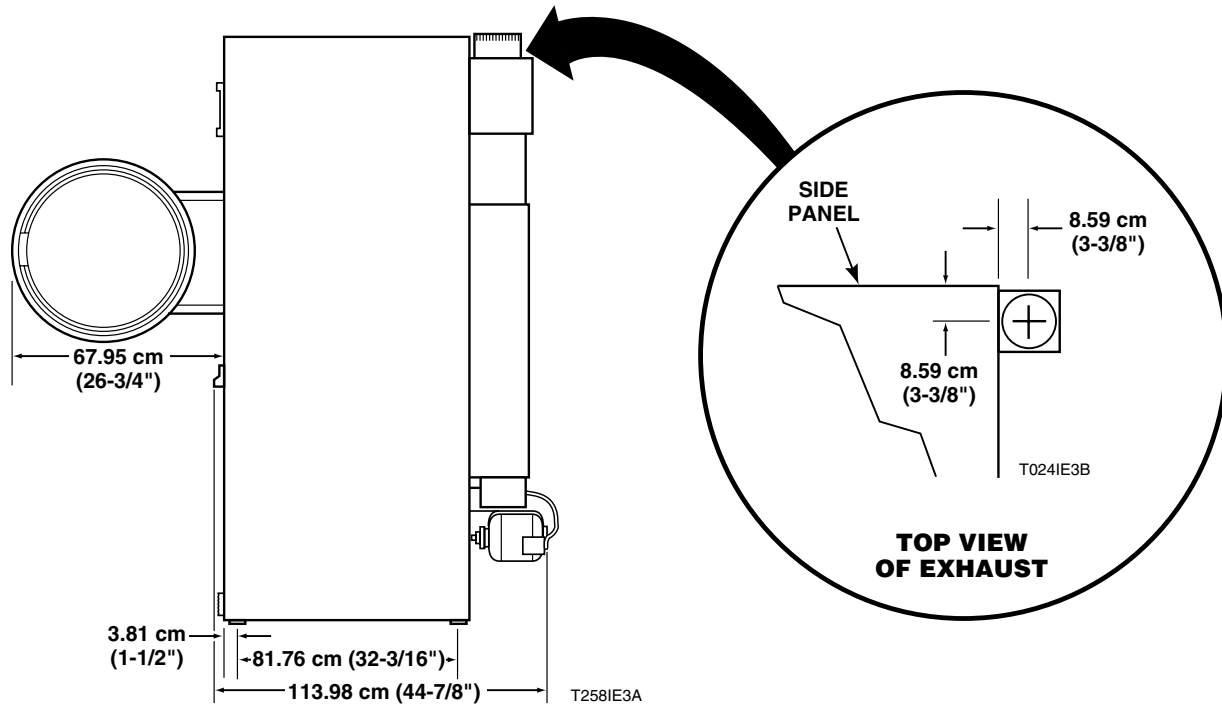

CLEARANCES: Minimum to nearest Combustible Material
 Top — 12" (30.5 cm) Minimum. 0" permitted for first 4" (10.2 cm) along front of machine.
 Back — 0" - 24" (61 cm) Minimum recommended for service access.
 Sides — 0" Permitted.

30 Pound (13 kg) Narrow Cabinet Gas Tumbler

Cabinet Finish:	Electrostatically applied thermosetting polyester.
Cylinder:	26.5" x 30" (67.3 cm x 76.2 cm) perforated galvanized steel with three baffles
Motor:	1/3 H.P., lifetime lubricated, internal overload protected
Electrical Requirements:	230 Volt, 50 Hertz, 1 Phase; 5.5 Amps
Gas Consumption:	75,000 BTU per hour (79.1 MJ/hr.)
Gas Connection:	1/2" (12.7 mm) N.P.T.
Types of Gas:	Factory equipped with Natural/Mixed Gas (6 1/2 ± 1 1/2 inch water column line pressure) (1.62 ± .37 kPa); or Liquefied Petroleum gas (11 ± .3" water column line pressure) (2.74 ± .07 kPa)
Air Flow:	370 C.F.M. at 0.5" W.C. (175 liters/sec. at 1.25 mBar)
Net Weight:	350 Pounds (159 kg) (approximate)

30 Pound (13 kg) Narrow Cabinet Electric Tumbler

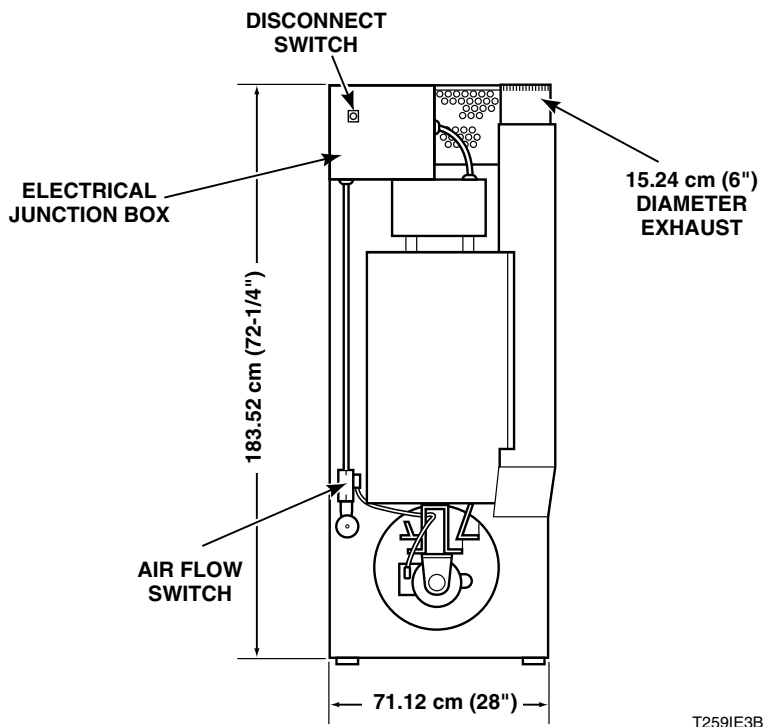
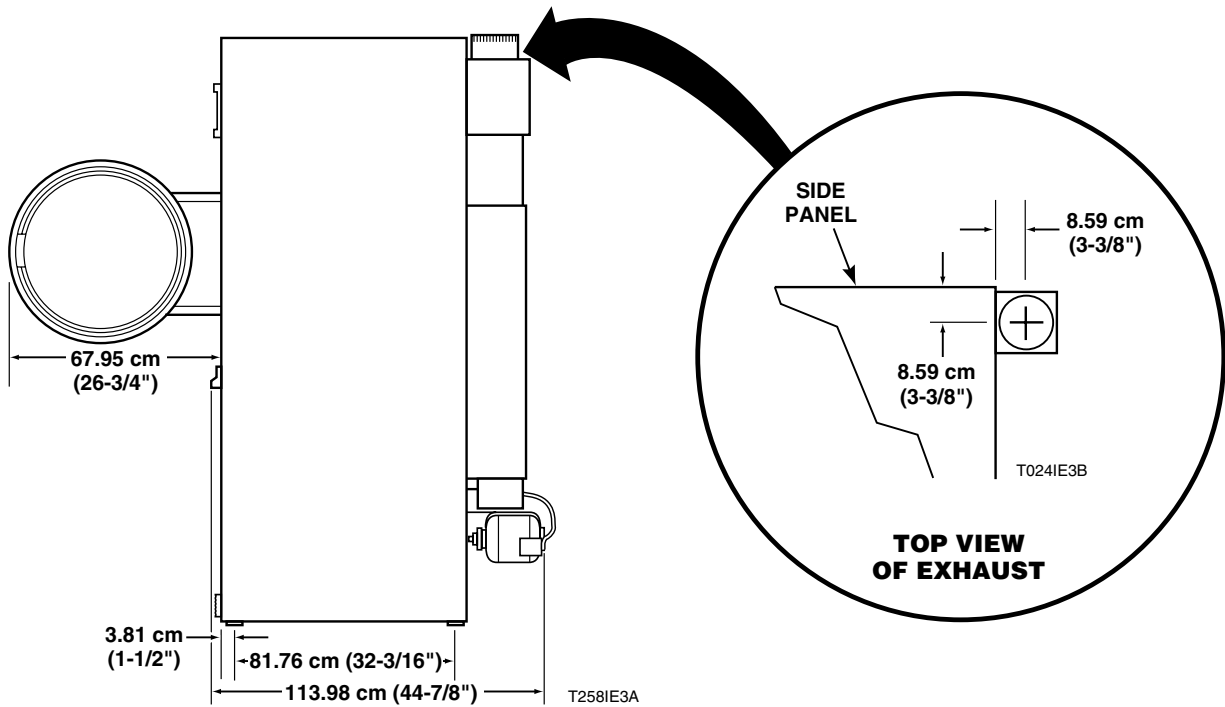

CLEARANCES: Minimum to nearest Combustible Material
Top — 12" (30.5 cm) Minimum. 0" permitted for first 4" (10.2 cm) along front of machine.
Back — 0" - 24" (61 cm) Minimum recommended for service access.
Sides — 0" Permitted.

30 Pound (13 kg) Narrow Cabinet Electric Tumbler

Cabinet Finish:	Electrostatically applied thermosetting polyester.
Cylinder:	26.5" x 30" (67.3 cm x 76.2 cm) perforated galvanized steel with three baffles
Motor:	1/3 H.P., lifetime lubricated, internal overload protected
Electrical Requirements: (See nameplate for voltage of your tumbler)	230 Volt, 50 Hertz, 1 Phase; 90 Amps 230 Volt, 50 Hertz, 3 Phase; 53 Amps 380 Volt, 50 Hertz, 3 Phase; 33 Amps 415 Volt, 50 Hertz, 3 Phase; 30 Amps
Element:	18,000 Watts
Air Flow :	625 C.F.M. at 0.5" W.C. (294 liters/sec. at 1.25 mBar)
Net Weight:	410 Pounds (184.5 kg) (approximate)

30 Pound (13 kg) Gas Tumbler

CLEARANCES: Minimum to nearest Combustible Material
Top — 12" (30.5 cm) Minimum.
0" permitted for first 4" (10.2 cm) along front of machine.
Back — 0" - 24" (61 cm) Minimum recommended for service access.
Sides — 0" Permitted.

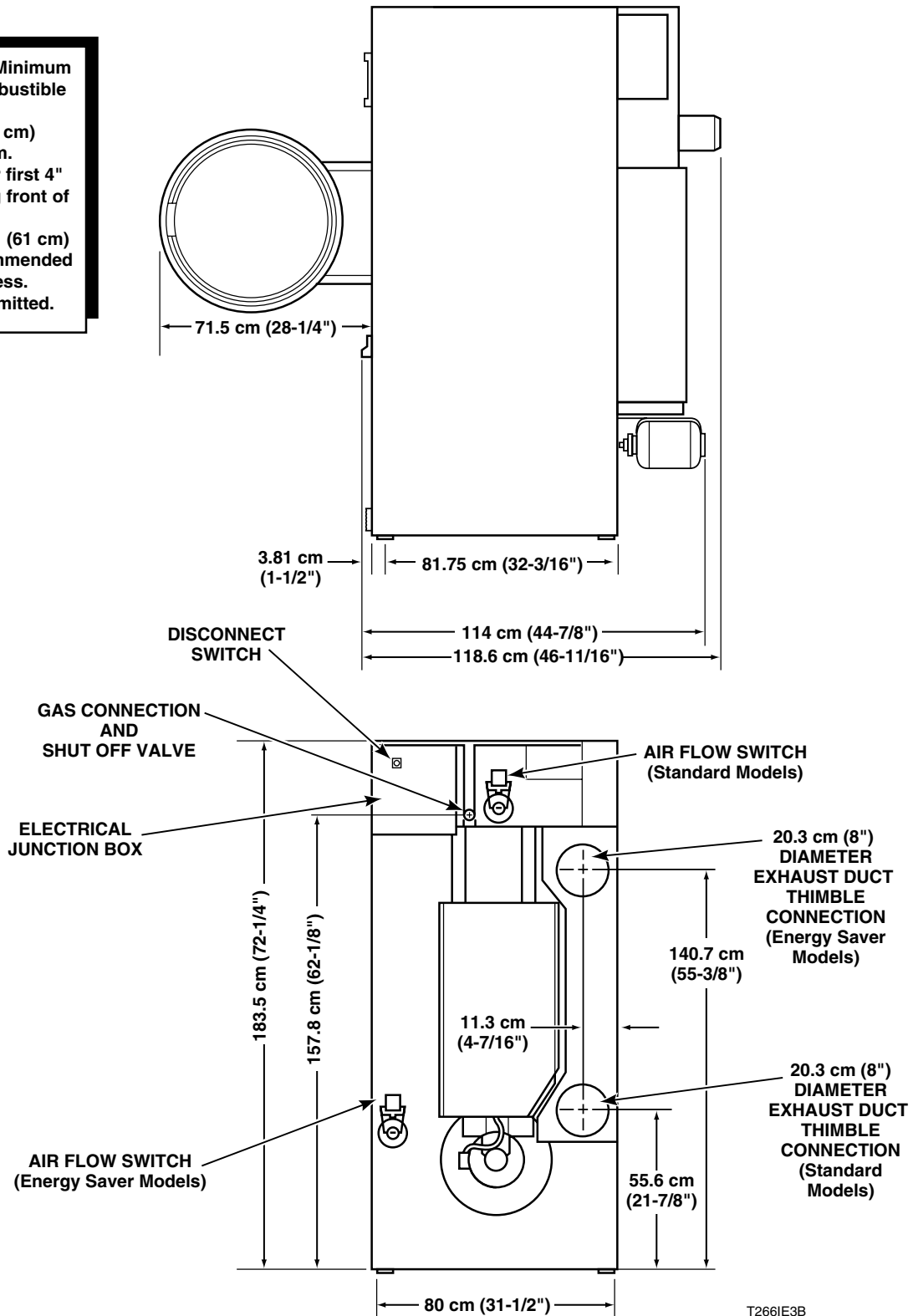

T2661E3B

30 Pound (13 kg) Gas Tumbler

Cabinet Finish:	Electrostatically applied thermosetting polyester
Cylinder:	30" x 30" (76.2 x 76.2 cm) perforated galvanized steel with three baffles; 30 pounds (13.6 kg) dry weight (cotton load)
Motor:	1/3 H.P., lifetime lubricated, internal overload protected
Electrical Requirements:	230 Volt, 50 Hertz, 1 Phase, 5.5 Amp
Gas Consumption:	Energy Saver Models — 80,000 BTU per hour (84.4 MJ/hr.) Standard Models — 105,000 BTU per hour (110.8 MJ/hr.)
Types of Gas:	Factory equipped with Natural/Mixed Gas (6 1/2 ± 1 1/2 inch water column line pressure) (1.62 ± .37 kPa); or Liquefied Petroleum gas (11 ± .3" water column line pressure) (2.74 ± .07 kPa)
Gas Connection:	1/2 inch (12.7 mm) N.P.T.
Air Flow:	600 C.F.M. at 0.5 " W.C. (283 liters/sec. at 1.25 mBar)
Net Weight:	450 Pounds (204 kg.) (approximate)
Calorific Value:	Natural Gas — 8900 kCal/m ³ (37.2 MJ/m ³) L.P. Gas — 22,250 kCal/m ³ (93.1 MJ/m ³)

30 Pound (13 kg) Electric Tumbler

CLEARANCES: Minimum to nearest Combustible Material
Top — 12" (30.5 cm) Minimum.
0" permitted for first 4" (10.2 cm) along front of machine.
Back — 0" - 24" (61 cm) Minimum recommended for service access.
Sides — 0" Permitted.

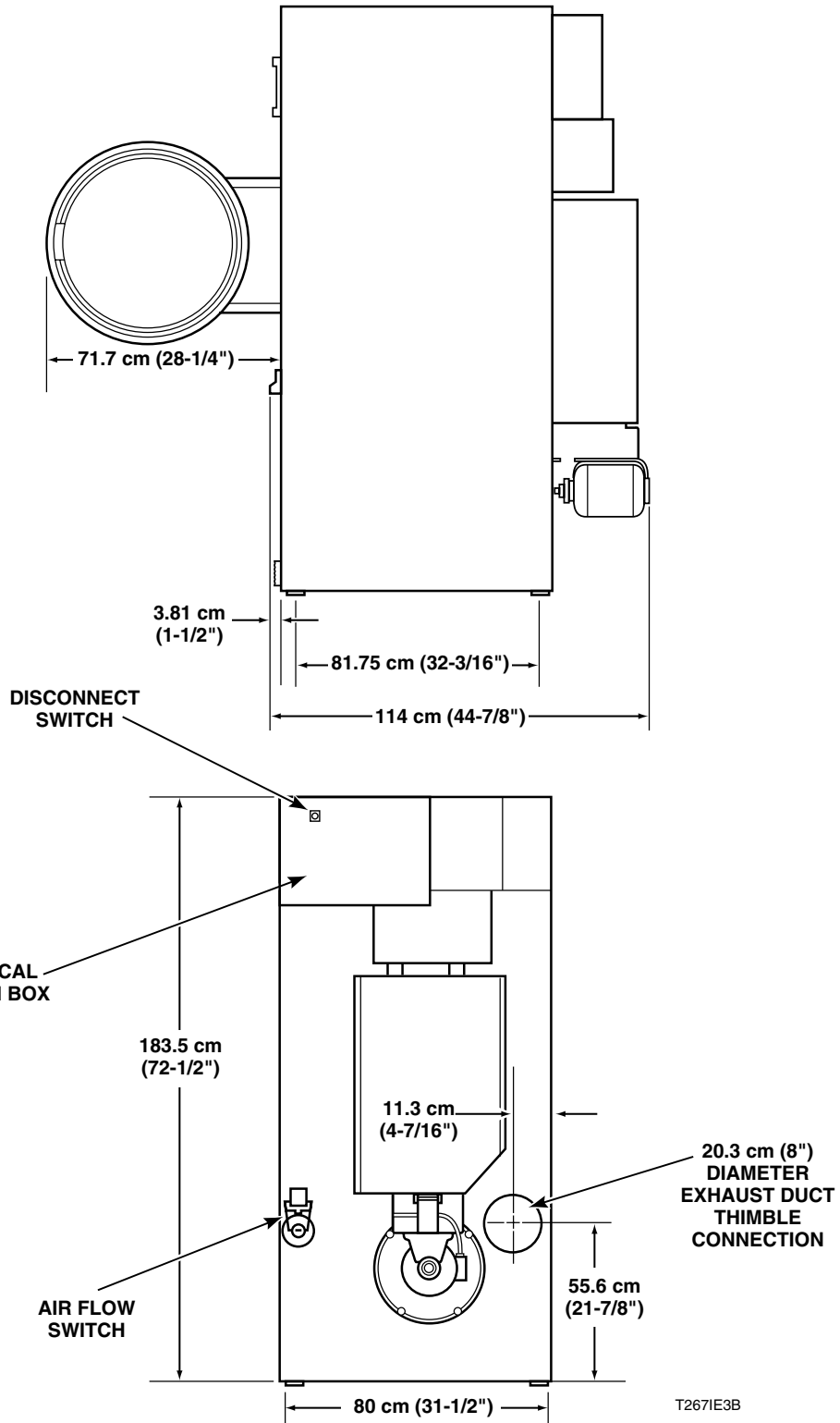

30 Pound (13 kg) Electric Tumbler

Cabinet Finish:	Electrostatically applied thermosetting polyester
Cylinder:	30" x 30" (76.2 x 76.2 cm) perforated galvanized steel with three baffles; 30 pounds (13.6 kg) dry weight (cotton load)
Motor:	1/3 H.P., lifetime lubricated, internal overload protected
Electrical Requirements: (see nameplate for voltage of your tumbler)	230 Volt, 50 Hertz, 1 Phase, 90 Amp 230 Volt, 50 Hertz, 3 Phase, 54 Amp 380 Volt, 50 Hertz, 3 Phase, 33 Amp 415 Volt, 50 Hertz, 3 Phase, 30 Amp
Element:	21,000 Watts (all voltages)
Air Flow:	600 C.F.M. at 0.5" W.C. (283 liters/sec. at 1.25 mBar)
Net Weight:	450 pounds (204 kg) (approximate)

30 Pound (13 kg) Steam Tumbler

CLEARANCES: Minimum to nearest Combustible Material
Top — 12" (30.5 cm) Minimum.
0" permitted for first 4" (10.2 cm) along front of machine.
Back — 0" - 24" (61 cm) Minimum recommended for service access.
Sides — 0" Permitted.

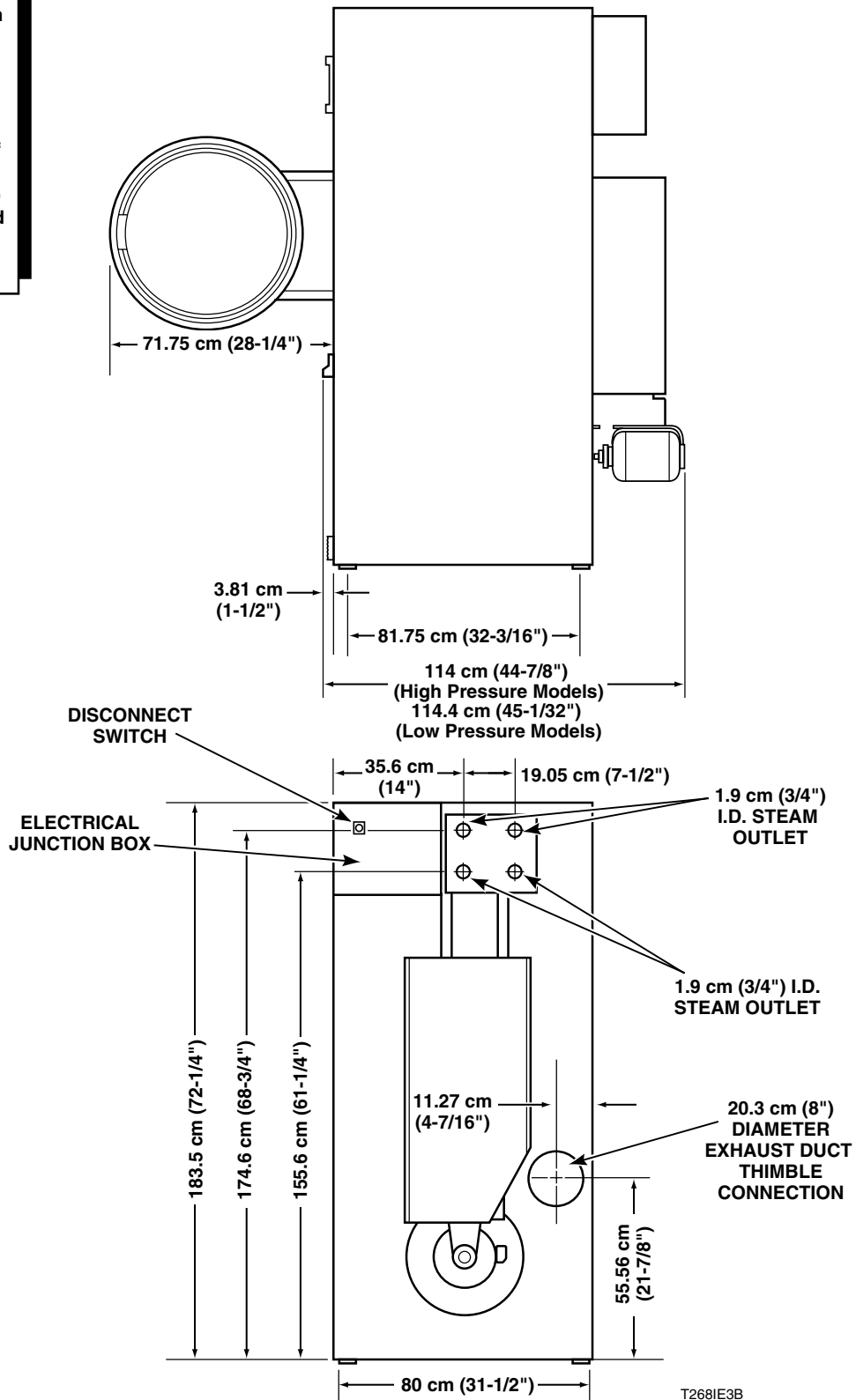

30 Pound (13 kg) Steam Tumbler

Cabinet Finish:	Electrostatically applied thermosetting polyester
Cylinder:	30" x 30" (76.2 x 76.2 cm) perforated galvanized steel with three baffles; 30 pounds dry weight (13.6 kg) (cotton load)
Motor:	High Pressure (4 coils) ½ H.P. Low Pressure (4 coils) ¾ H.P.
Boiler Horsepower:	4 coil High Pressure – 3.7 Bhp (123,950 BTU/hr., 58 kg/hr, 31,235 kCal/hr.) 4 coil Low Pressure – 2.6 Bhp (87,100 BTU/hr., 40 kg/hr, 21,949 kCal/hr.)
Electrical Requirements: (see nameplate for voltage of tumbler)	<p>Low Pressure: 230 Volt, 50 Hertz, 1 Phase, 8 Amp 380 Volt, 50 Hertz, 3 Phase, 3 Amp 415 Volt, 50 Hertz, 3 Phase, 3 Amp</p> <p>High Pressure: 230 Volt, 50 Hertz, 1 Phase, 4 Amp 380-415 Volt, 50 Hertz, 3 Phase, 2 Amp</p>
Air Flow:	Low Pressure — 600 C.F.M. at 0.5 W.C. (283 liters/sec. at 1.25 mBar) High Pressure — 600 C.F.M. at 0.5 W.C. (283 liters/sec. at 1.25 mBar)
Net Weight:	470 pounds (214 kg) (approximate)

50 Pound (22 kg) Gas Non-reversing Tumblers

CLEARANCES: Minimum to nearest Combustible Material
Top — 12" (30.5 cm) Minimum.
0" permitted for first 4" (10.2 cm) along front of machine.
Back — 0" - 24" (61 cm) Minimum recommended for service access.
Sides — 0" Permitted.

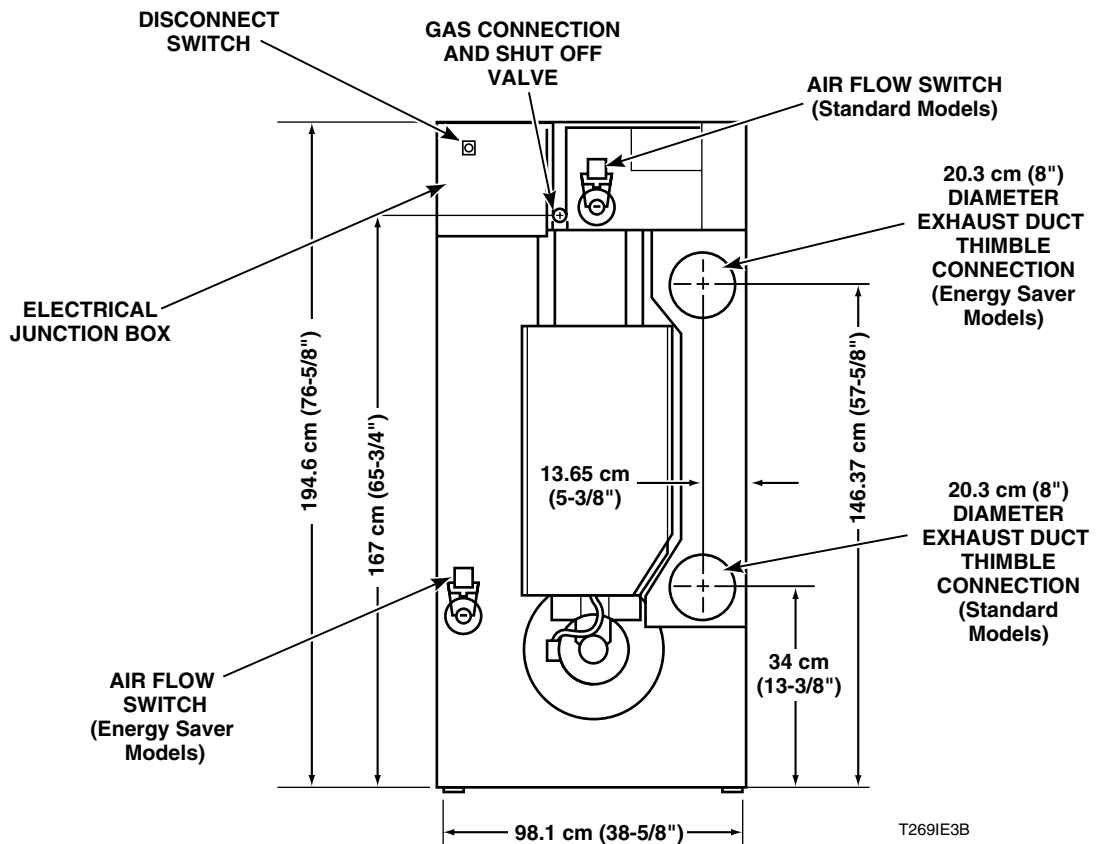
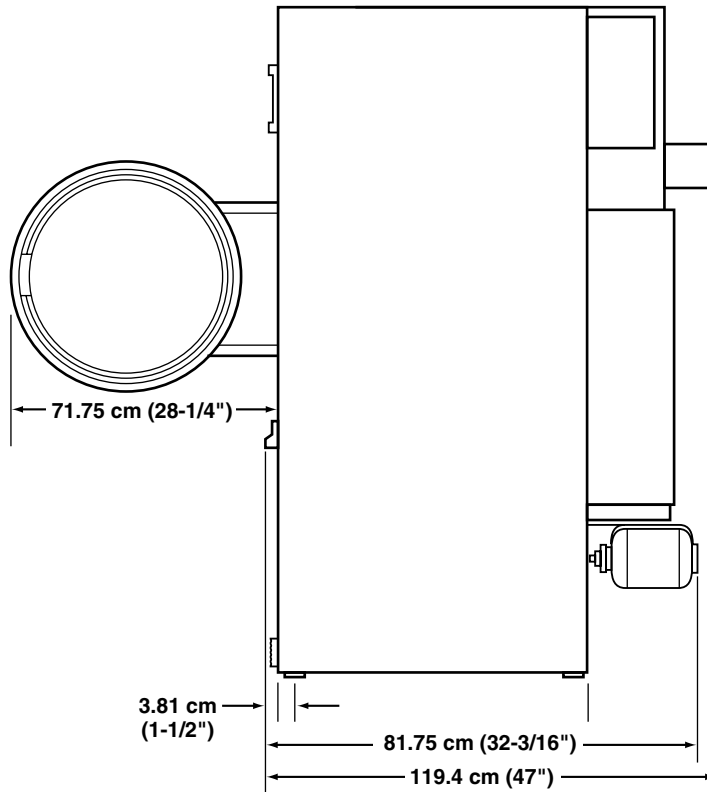

T2691E3B

50 Pound (22 kg) Gas Tumblers

Cabinet Finish:	Electrostatically applied thermosetting polyester
Cylinder:	37" x 30" (94 cm x 76.2 cm) perforated galvanized steel with four baffles; 50 pounds (22.7 kg) dry weight (cotton load)
Motor: (Nonreversing Models)	1/2 H.P., lifetime lubricated, internal overload protected (See below for reversing models.)
Electrical Requirements: Non-Reversing Models	230 Volt, 50 Hertz, 1 Phase, 6.0 Amp
Electrical Requirements: Reversing Models	230 Volt, 50 Hertz, 1 Phase, 8.0 Amp
Gas Consumption:	Energy Saver Models — 95,000 BTU per hour (100.2 MJ/hr.) Standard Models — 120,000 BTU per hour (126.6 MJ/hr.)
Types of Gas:	Factory equipped with Natural/Mixed Gas (6-1/2 ± 1-1/2 inch water column line pressure) (1.62 ± .37 kPa); or Liquefied Petroleum gas (11 ± .3" water column line pressure) (2.74 ± .07 kPa)
Gas Connection:	1/2 inch (12.7 mm) N.P.T.
Air Flow:	Energy Saver Models — 390 C.F.M. at 0.5" W.C. (185 liters/sec. at 1.25 mBar) Standard Models — 600 C.F.M. at 0.5" W.C. (284 liters/sec. at 1.25 mBar)
Net Weight:	545 Pounds (247 kg) (approximate)
Calorific Value:	Natural Gas — 8900 kCal/m ³ (37.2 MJ/m ³) L.P. Gas — 22,250 kCal/m ³ (93.1 MJ/m ³)

REVERSING MOTOR SIZES					
		GAS	ELECTRIC	STEAM	
				HIGH PRESSURE	LOW PRESSURE
50 LB.	FAN	1/3 H.P.	1/3 H.P.	1/3 H.P.	1/2 H.P.
	CYLINDER	1/3 H.P.	1/3 H.P.	1/3 H.P.	1/3 H.P.

50 Pound (22 kg) Gas and Steam Reversing Tumblers

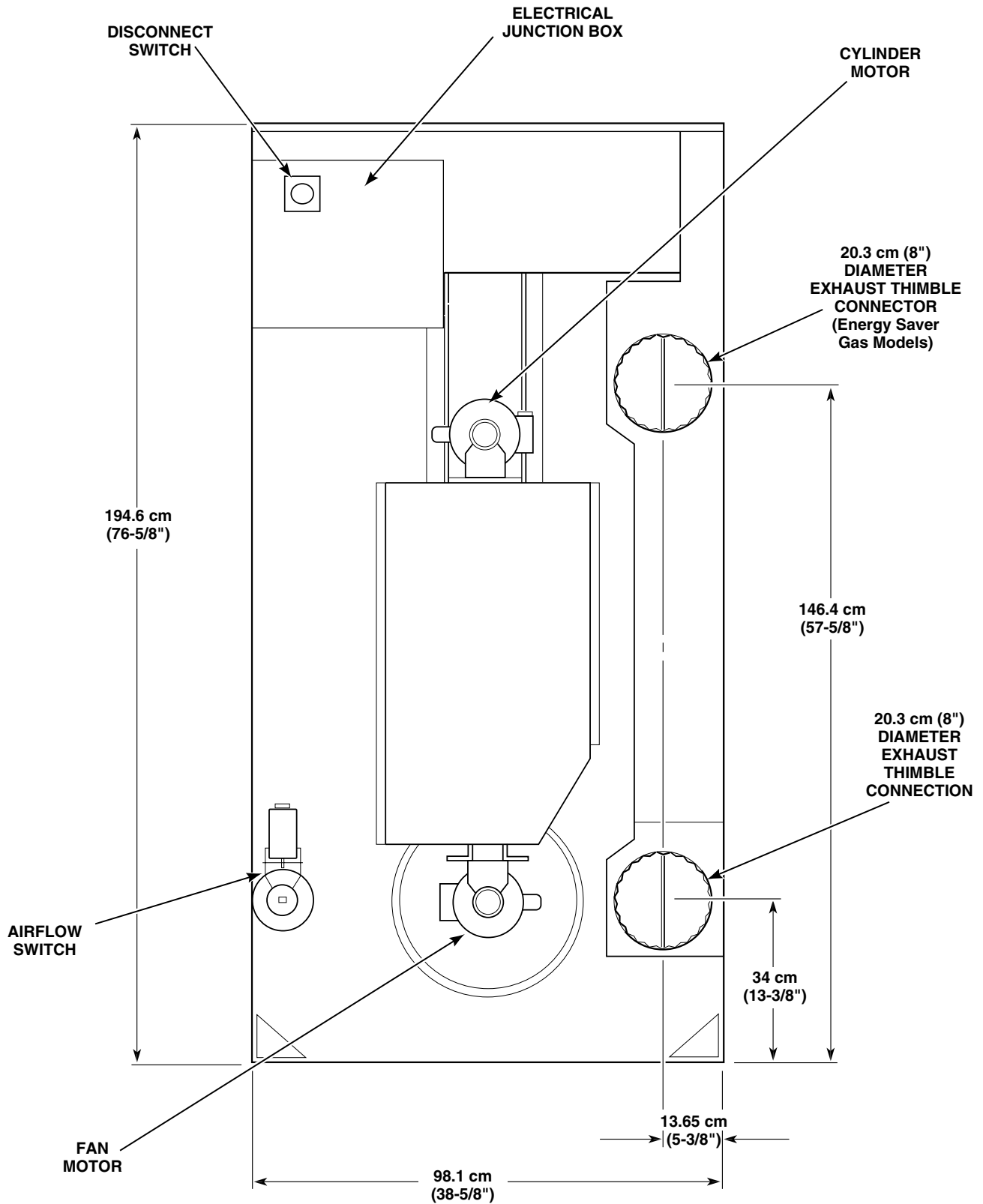

T264IE3B

50 Pound (22 kg) Electric Non-reversing Tumblers

CLEARANCES: Minimum to nearest Combustible Material
Top — 12" (30.5 cm) Minimum.
0" permitted for first 4" (10.2 cm) along front of machine.
Back — 0" - 24" (61 cm) Minimum recommended for service access.
Sides — 0" Permitted.

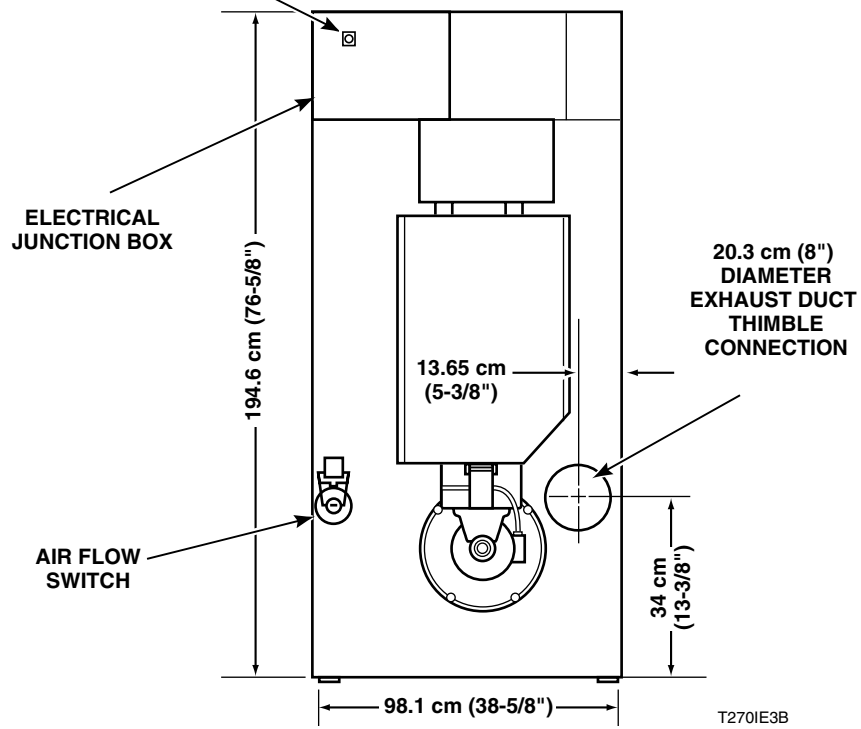
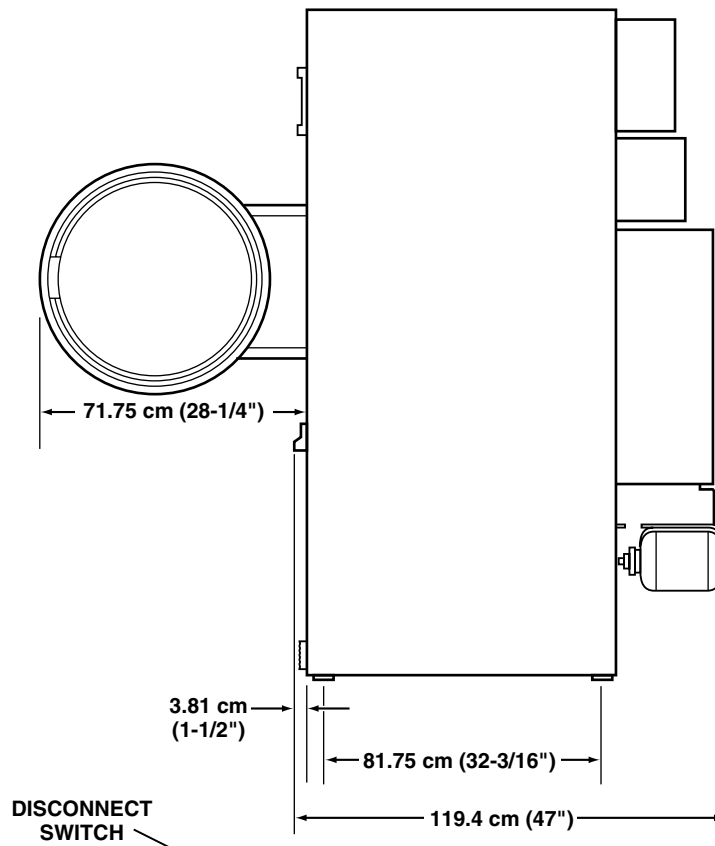

T270IE3B

50 Pound (22 kg) Electric Tumblers

Cabinet Finish:	Electrostatically applied thermosetting polyester
Cylinder:	37" x 30" (94 x 76.2 cm) perforated galvanized steel with four baffles; 50 pounds (22.7 kg) dry weight (cotton load)
Motor: (Nonreversing models)	1/2 H.P., lifetime lubricated, internal overload protected (See below for reversing models.)
Electrical Requirements: (see nameplate for voltage of your tumbler)	230 Volt, 50 Hertz, 1 Phase, 90 Amp 230 Volt, 50 Hertz, 3 Phase, 78 Amp 380 Volt, 50 Hertz, 3 Phase, 48 Amp 415 Volt, 50 Hertz, 3 Phase, 45 Amp
Element:	30,000 watts (all voltages) Long life nichrome wire
Air Flow:	900 C.F.M. maximum at .5" W.C. (425 liters/sec at 1.25 mBar)
Net Weight:	550 pounds (250 kg) (approximate)

REVERSING MOTOR SIZES					
		GAS	ELECTRIC	STEAM	
				HIGH PRESSURE	LOW PRESSURE
50 LB.	FAN	1/3 H.P.	1/3 H.P.	1/3 H.P.	1/2 H.P.
	CYLINDER	1/3 H.P.	1/3 H.P.	1/3 H.P.	1/3 H.P.

50 Pound (22 kg) Electric Reversing Tumblers

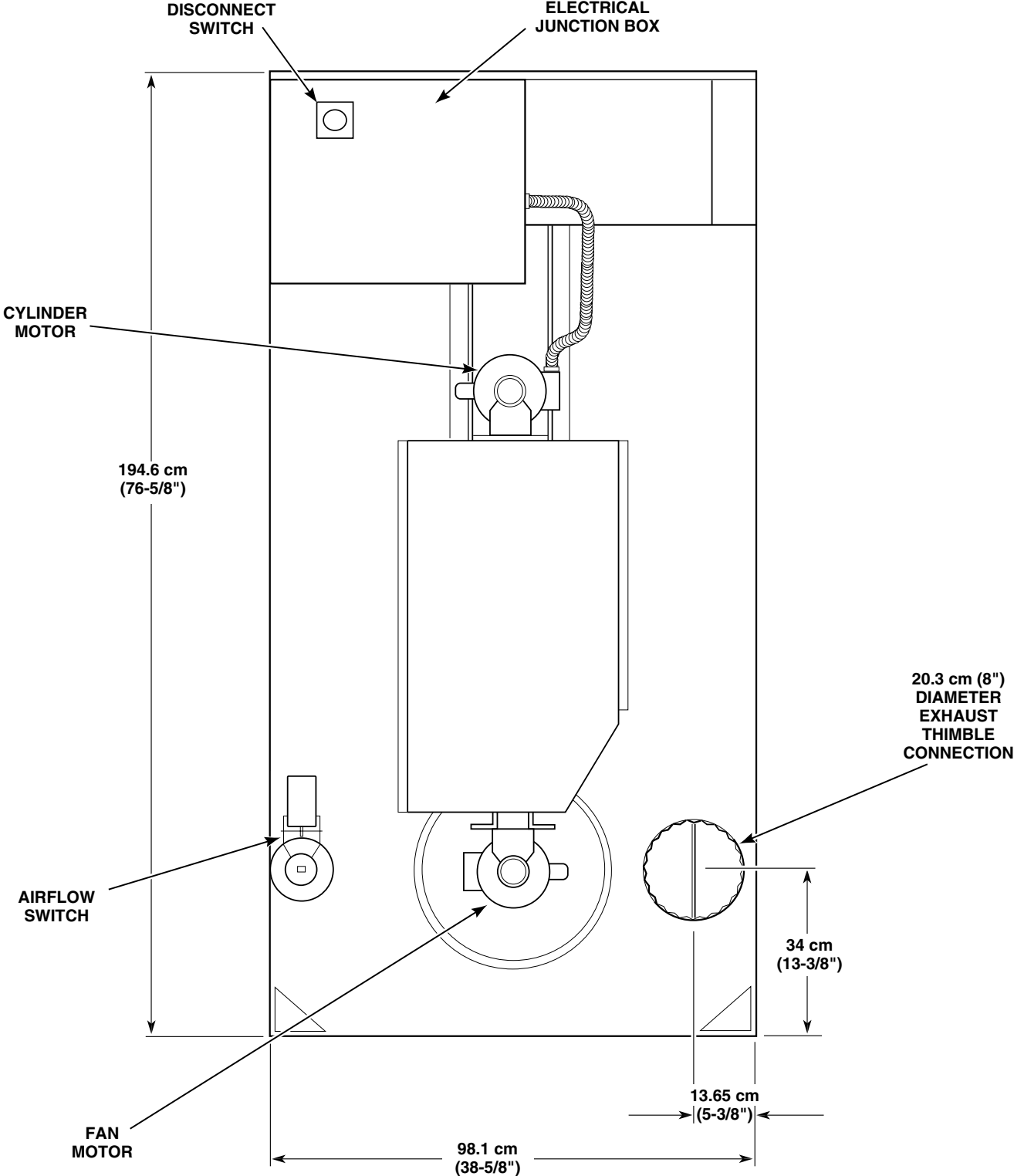

T263IE3B

50 Pound (22 kg) Steam Non-reversing Tumblers

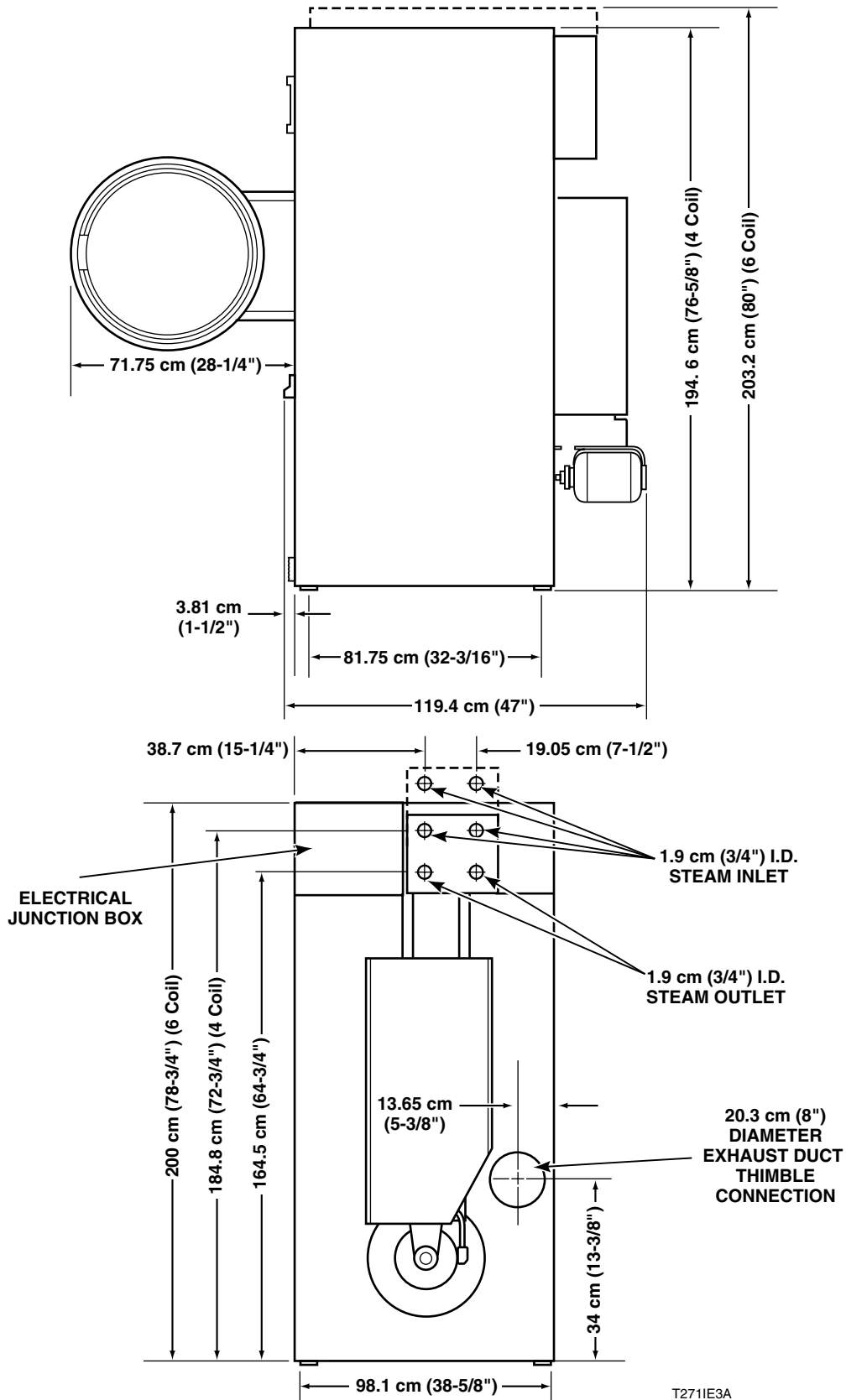

50 Pound (22 kg) Steam Tumblers

Cabinet Finish:	Electrostatically applied thermosetting polyester
Cylinder:	37" x 30" (94 x 76.2 cm) perforated galvanized steel with four baffles; 50 pounds (22.7 kg) dry weight (cotton load)
Motor: (Nonreversing Models)	High Pressure Steam — 1/2 H.P. Low Pressure Steam — 3/4 H.P. Both motors are lifetime lubricated, internal overload protected (See below for reversing models.)
Boiler Horsepower:	High Pressure Steam (6 Coil) — 4.60 BHP (154,100 BTU/hr, 72.1 kg/hr, 38,833 kCal/nr.) Low Pressure Steam (4 Coil) — 3.00 BHP (134,000 BTU/hr, 62.7 kg/hr, 33,768 kCal/hr.)
Electrical Requirements: (see nameplate for voltage of your tumbler)	Low Pressure 230 Volt, 50 Hertz, 1 Phase, 7.0 Amp High Pressure 230 Volt, 50 Hertz, 1 Phase, 7.0 Amp 380 Volt, 50 Hertz, 3 Phase, 3.0 Amp 415 Volt, 50 Hertz, 3 Phase, 2.5 Amp
Air Flow:	Low Pressure — 950 C.F.M. at 0.5" W.C. (449 liters/sec. at 1.25 mBar) High Pressure — 900 C.F.M. at 0.5" W.C. (426 liters/sec. at 1.25 mBar)
Net Weight:	4 Coil Tumbler — 565 pounds (257 kg) (approximate) 6 Coil Tumbler — 580 pounds (263 kg) (approximate)

REVERSING MOTOR SIZES					
		GAS	ELECTRIC	STEAM	
				HIGH PRESSURE	LOW PRESSURE
50 LB.	FAN	1/3 H.P.	1/3 H.P.	1/3 H.P.	1/2 H.P.
	CYLINDER	1/3 H.P.	1/3 H.P.	1/3 H.P.	1/3 H.P.

75 Pound (34 kg) Gas Non-reversing Tumblers

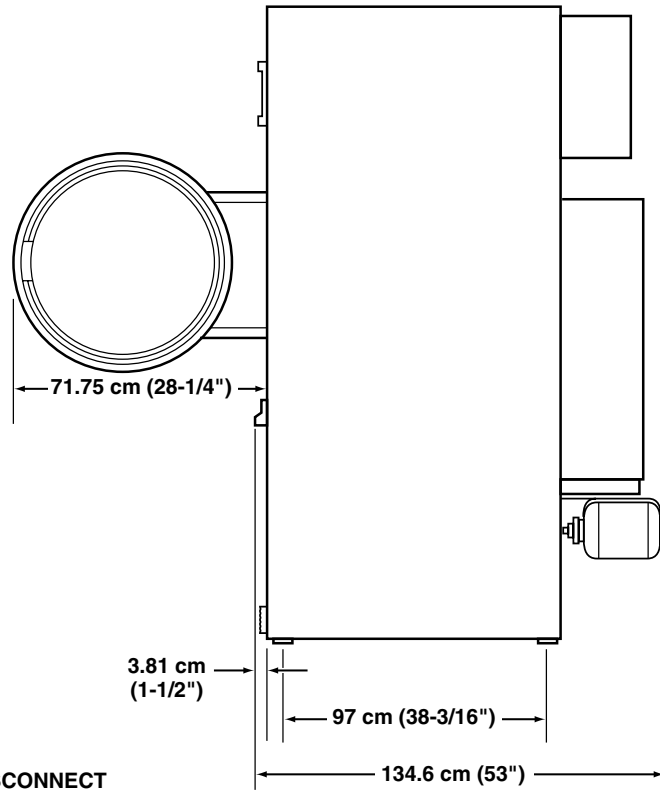

DISCONNECT SWITCH

ELECTRICAL JUNCTION BOX

GAS CONNECTION AND SHUT OFF VALVE

20.3 cm (8") DIAMETER EXHAUST DUCT THIMBLE CONNECTION (Standard Models)

AIR FLOW SWITCH

CLEARANCES: Minimum to nearest Combustible Material
 Top — 12" (30.5 cm) Minimum.
 0" permitted for first 4" (10.2 cm) along front of machine.
 Back — 0" - 24" (61 cm) Minimum recommended for service access.
 Sides — 0" Permitted.

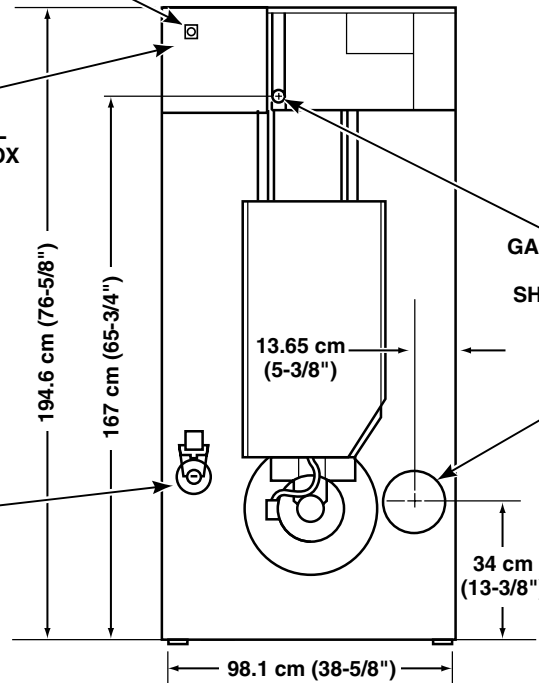

T272IE3B

75 Pound (34 kg) Gas and Steam Reversing Tumblers

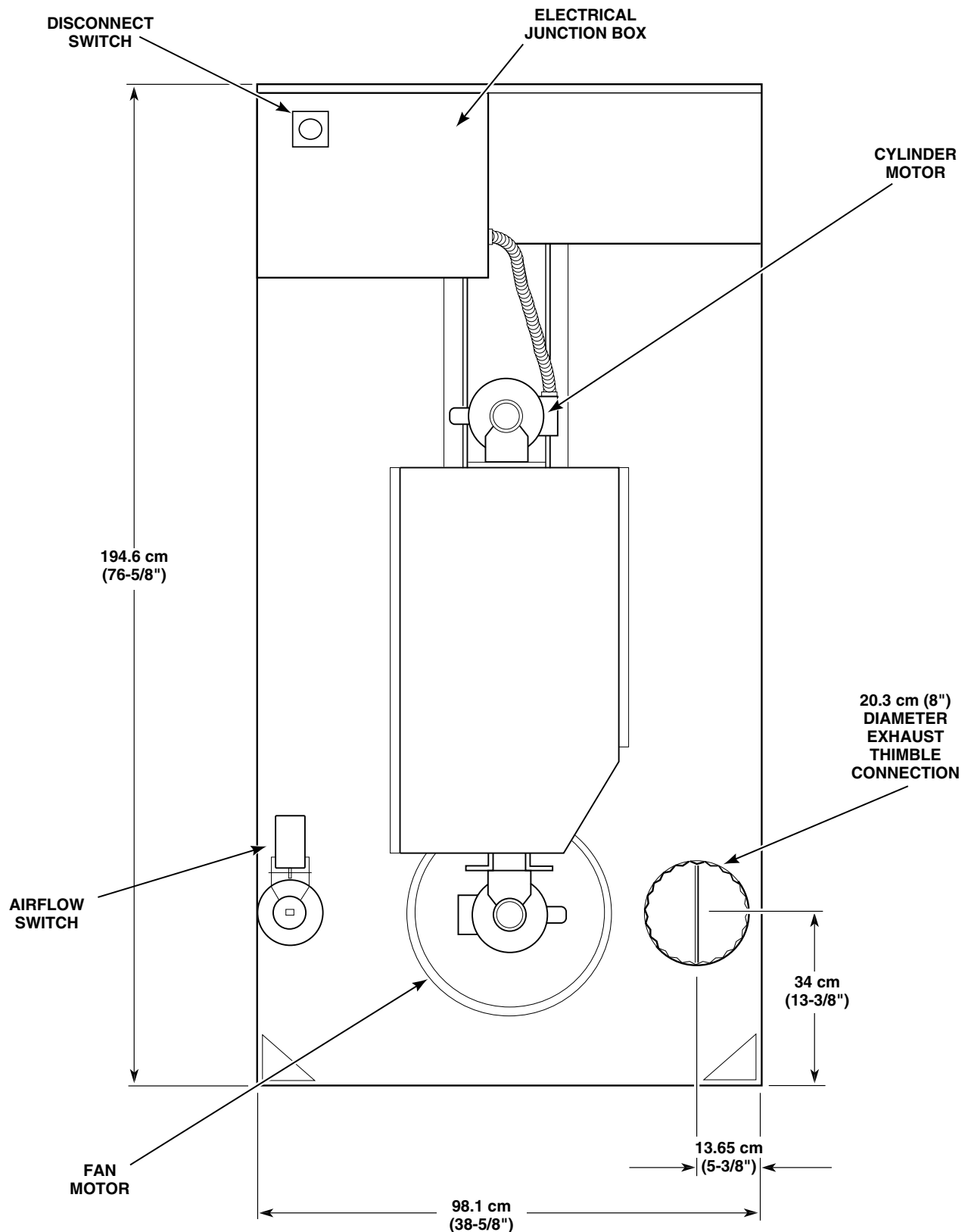

T265IE3B

75 Pound (34 kg) Gas Tumblers

Cabinet Finish:	Electrostatically applied thermosetting polyester
Cylinder:	37" x 36" (94 x 91.4 cm) perforated galvanized steel cylinder with four baffles; 75 pounds (34.1 kg) dry weight (cotton load)
Motor: (Non-reversing models)	3/4 H.P., lifetime lubricated, internal overload protected. (See below for reversing models.)
Electrical Requirements Nonreversing Models:	230 Volt, 50 Hertz, 1 Phase, 9.0 Amp
Electrical Requirements Reversing Models:	230 Volt, 50 Hertz, 1 Phase, 9.0 Amp
Gas Consumption:	165,000 B.T.U. per hour (174.1 MJ/hr.)
Types of Gas:	Factory equipped with Natural/Mixed gas (6-1/2 A 1-1/2 inch water column line pressure) (1.62 A .37 kPa); or Liquefied Petroleum gas (11.0 A .3 inch water column line pressure) (2.74 A .07 kPa)
Gas Connection:	1/2 inch (12.7 mm) N.P.T.
Air Flow:	1000 C.F.M. at 0.5" W.C. (472 liters/sec. at 1.25 mBar)
Net Weight:	550 Pounds (250 kg) (approximate)
Calorific Value:	Natural Gas — 8900 kCal/m ³ (37.2 MJ/m ³) L.P. Gas — 22250 kCal/m ³ (93.1 MJ/m ³)

REVERSING MOTOR SIZES					
		GAS	ELECTRIC	STEAM	
				HIGH PRESSURE	LOW PRESSURE
75 LB.	FAN	1/3 H.P.	1/3 H.P.	1/3 H.P.	1/2 H.P.
	CYLINDER	1/3 H.P.	1/3 H.P.	1/3 H.P.	1/3 H.P.

75 Pound (34 kg) Electric Non-reversing Tumblers

CLEARANCES: Minimum to nearest Combustible Material
Top — 12" (30.5 cm) Minimum.
0" permitted for first 4" (10.2 cm) along front of machine.
Back — 0" - 24" (61 cm) Minimum recommended for service access.
Sides — 0" Permitted.

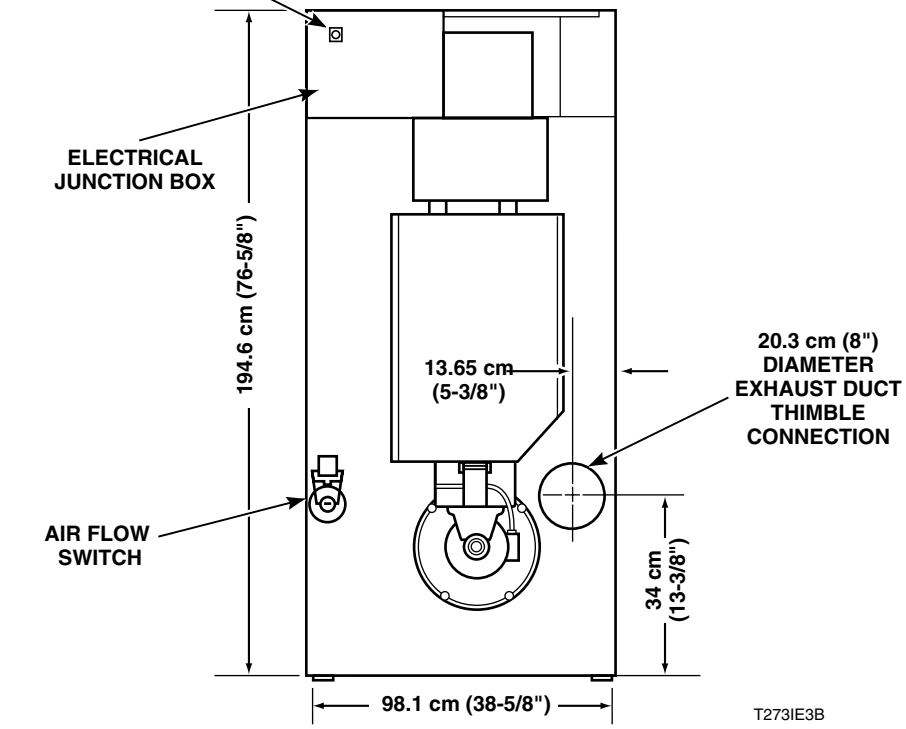
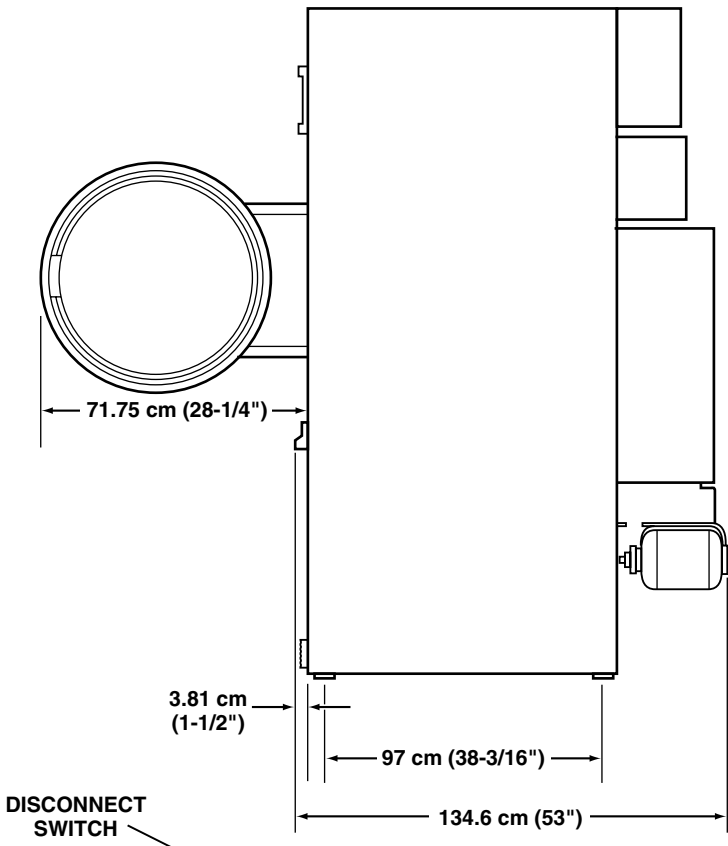

T273IE3B

75 Pound (34 kg) Electric Reversing Tumblers

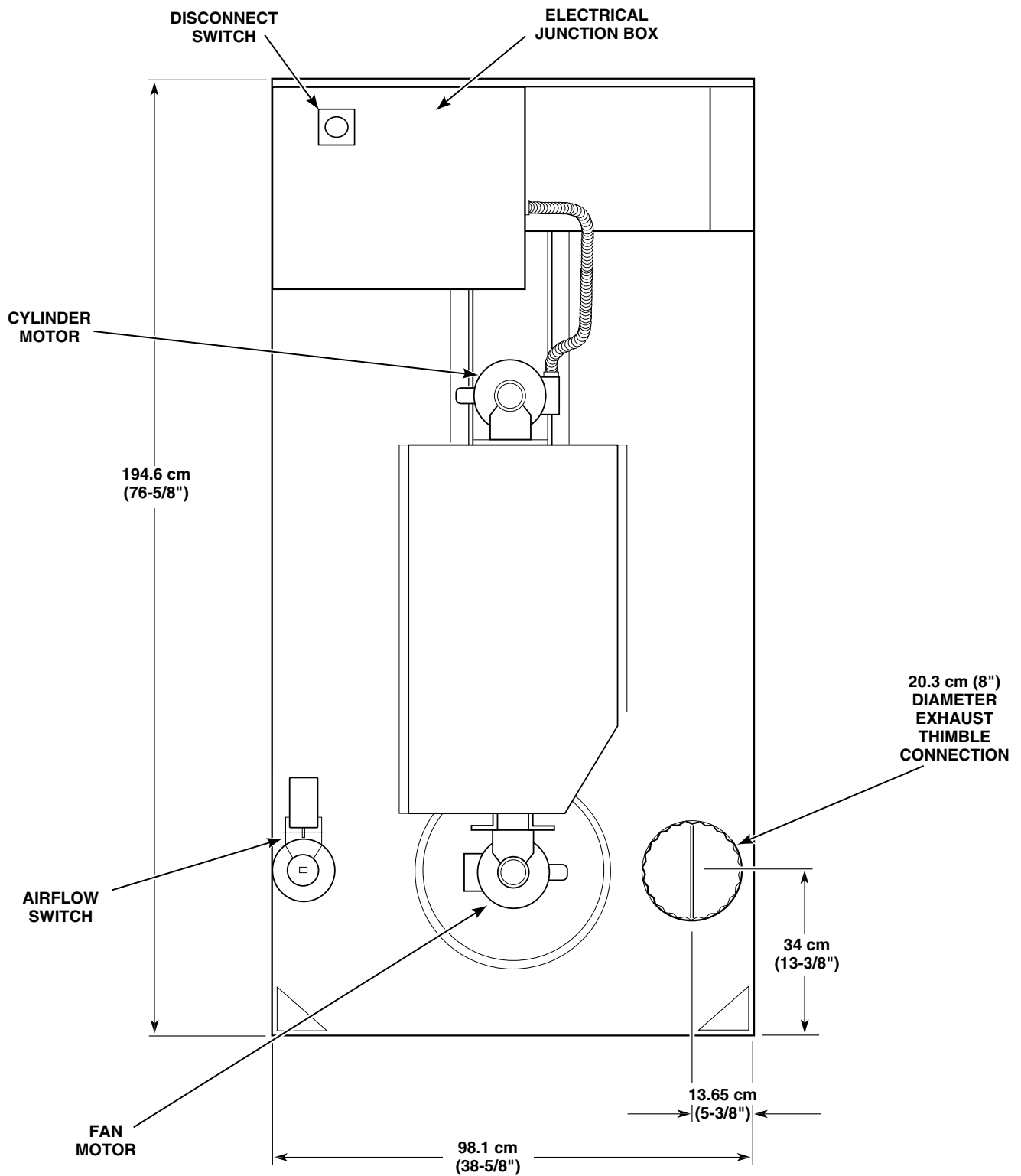

T263IE3B

75 Pound (34 kg) Electric Tumblers

Cabinet Finish:	Electrostatically applied thermosetting polyester
Cylinder:	3 7" x 36" (94 x 91.4 cm) perforated galvanized steel with four baffles; 75 pounds (34.1 kg) dry weight (cotton load)
Motor: (Non-reversing models)	3/4 H.P., lifetime lubricated internal overload protected. (See below for reversing models.)
Electrical Requirements: (See nameplate for voltage of your tumbler)	230 Volt, 50 Hertz, 3 Phase, 77 Amps 380 Volt, 50 Hertz, 3 Phase, 50 Amps 415 Volt, 50 Hertz, 3 Phase, 45 Amps
Element:	30,000 Watts (all models)
Air Flow:	850 C.F.M. at 0.5" W.C. (401 liters/sec at 1.25 mBar)
Net Weight:	555 Pounds (252 kg) (approximate)

REVERSING MOTOR SIZES					
		GAS	ELECTRIC	STEAM	
				HIGH PRESSURE	LOW PRESSURE
75 LB.	FAN	1/3 H.P.	1/3 H.P.	1/3 H.P.	1/2 H.P.
	CYLINDER	1/3 H.P.	1/3 H.P.	1/3 H.P.	1/3 H.P.

75 Pound (34 kg) Steam Non-reversing Tumblers

CLEARANCES: Minimum to nearest Combustible Material
Top — 12" (30.5 cm) Minimum.
0" permitted for first 4" (10.2 cm) along front of machine.
Back — 0" - 24" (61 cm) Minimum recommended for service access.
Sides — 0" Permitted.

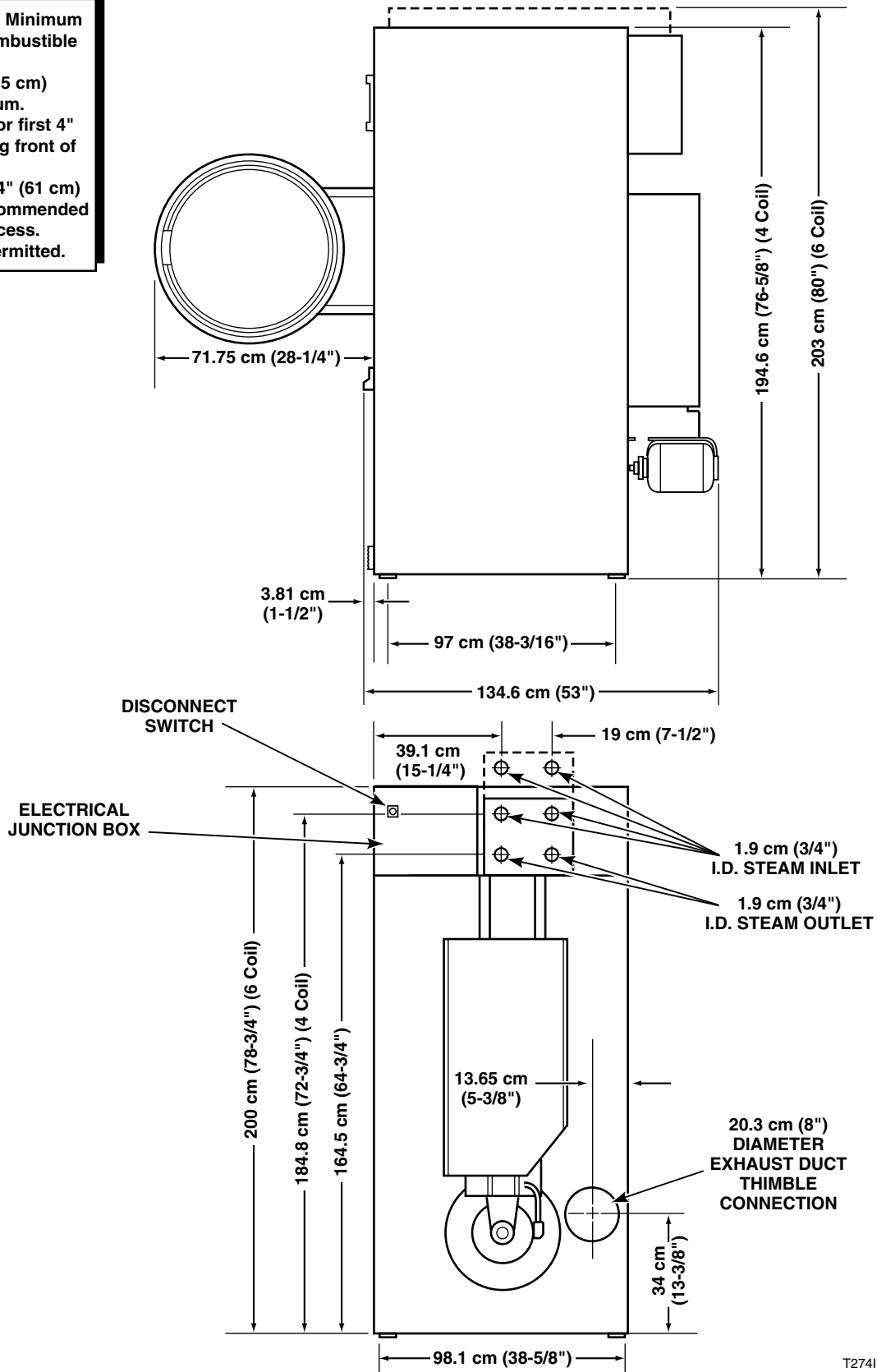

T274IE3B

75 (34 kg) Pound Steam Tumblers

Cabinet Finish:	Electrostatically applied thermosetting polyester
Cylinder:	37" x 36" (94 x 91.4 cm) perforated galvanized steel with four baffles; 75 pounds (34.1 kg) dry weight (cotton load)
Motor: (Non-reversing models)	High Pressure Steam — 3/4 H.P. Low Pressure Steam — 3/4 H.P. Both motors are lifetime lubricated, internal overload protected. (See below for reversing models.)
Boiler Horsepower:	High Pressure Steam (6 Coil) — 4.60 BPH (154,100 BTU/hr., 72.1 kg/hr., 38,833 kCal/hr.) Low Pressure Steam (4 Coil) — 4.00 BHP (134,000 BTU/hr., 62.7 kg/hr., 33,768 kCal/hr.)
Electrical Requirements: (See nameplate for voltage of your tumbler)	Low Pressure — 230 Volt, 50 Hertz, 1 Phase, 8.5 Amp High Pressure — 230 Volt, 50 Hertz, 1 Phase, 9.0 Amp
Air Flow:	Low Pressure — 950 C.F.M. at 0.5" W.C. (449 liters/sec at 1.25 mBar) High Pressure — 900 C.F.M. at 0.5" W.C. (425 liters/sec at 1.25 mBar)
Net Weight:	615 Pounds (280 kg) (approx.)

REVERSING MOTOR SIZES					
		GAS	ELECTRIC	STEAM	
				HIGH PRESSURE	LOW PRESSURE
75 LB.	FAN	1/3 H.P.	1/3 H.P.	1/3 H.P.	1/2 H.P.
	CYLINDER	1/3 H.P.	1/3 H.P.	1/3 H.P.	1/3 H.P.

SECTION II

Installation Instructions

RECEIVING INSPECTION

Upon delivery, visually inspect crate carton and parts for any visible shipping damage. If crate, carton or cover are damaged or signs of possible damage are evident, have carrier note condition on shipping papers before shipping receipt is signed, or advise carrier of condition as soon as it is discovered.

Remove crate and protective cover as soon as possible and check items listed on packing list.

Advise carrier of any damaged or missing articles as soon as possible. A written claim should be filed with carrier immediately if articles are damaged or missing.

IMPORTANT: Remove shipping tape from two back draft dampers located in exhaust thimble.

MATERIALS REQUIRED (Obtain Locally)

GAS, ELECTRIC OR STEAM DRYING TUMBLERS

- One circuit breaker.

GAS DRYING TUMBLERS ONLY

- One gas shut-off valve for gas service line to each tumbler.

STEAM DRYING TUMBLERS ONLY

- One steam shut-off gate valve for steam service line to be connected upstream of solenoid steam valve.

- Two steam shut-off gate valves for each condensate return line.
- Flexible steam hoses with a 125 psig (pounds per square inch gauge) (8.79 kg/sq. cm) working pressure for connecting steam coils, *Figures 24 and 25*.
- Two steam traps for steam coil outlet to condensate return line.
- One steam pressure relief valve rated at 125 psig. (8.79 kg/cm²).

FACILITIES REQUIRED

FLOOR

Drying tumbler may be installed on any level floor capable of supporting 100 pounds per square foot (488 kg/m²). Floor covering materials such as carpeting or tile should be removed.

LAYOUT

Whenever possible, tumbler should be installed along an outside wall where duct length can be kept to a minimum, and make-up air can be easily accessed.

Construction must not block airflow at top rear of tumbler. Doing so would prevent adequate air supply to tumbler's combustion chamber.

VENTING

For maximum efficiency and minimum lint accumulation, tumbler air must be exhausted to outdoors by shortest possible route.

Proper sized exhaust ducts are essential for proper operation. All elbows should be sweep type. Do not install elbows with a radius less than shown in table below. Exhaust ducts must be assembled so interior surfaces are smooth to reduce accumulation of lint. Do not use sheet metal screws to join vent sections. Improperly sized or assembled ductwork causes excess back pressure which results in slow drying, lint collecting in duct, lint blowing back into room, and increased fire hazard.

Exhaust ducts shall be constructed of sheet metal or other noncombustible material. Such ducts must be equivalent in strength and corrosion resistance to ducts made of galvanized sheet steel not less than 0.0195 inches (0.495 mm) thick.

Where exhaust duct pierces a combustible wall or ceiling, an opening having a diameter of 4 inches (10.2 cm) larger than diameter of exhaust duct shall be provided, with duct centered in opening. When ducts pass through walls, ceilings, floors or partitions, space around the duct shall be sealed with non-combustible material. See *Figures 1, 2 and 3.*

• **Individual Venting**

For maximum efficiency and performance, it is preferred to exhaust tumbler(s) individually to outdoors. **At no point may cross area of installed venting be less than cross area of exhaust thimble of tumbler.**

Maximum allowable length of venting is 14 feet (4.3 m) and two 90° elbows or equivalent. If equivalent length of a duct required for an installation exceeds maximum allowable equivalent length, diameter of a round duct must be increased by 10% for each additional 20 feet (6.1 m). Cross section area of a rectangular duct must be increased by 20% for each additional 20 feet (6.1 m). Table below shows how to determine equivalent venting:

DUCT DIAMETER	EQUIVALENT LENGTH OF STRAIGHT DUCT
6" (15.2 cm)	One 90° elbow = 7' (2.1 m)
8" (20.3 cm)	One 90° elbow = 9.3' (2.83 m)
10" (25.4 cm)	One 90° elbow = 11.6' (3.5 m)
12" (30.5 cm)	One 90° elbow = 14' (4.3 m)
Equivalent Length (feet) (m) = 1.17 x Duct Diameter (inches) (cm)	

Example: A 6-inch (15.2 cm) diameter duct's equivalent length of 14 feet (4.3 m) of duct and two 90° elbows is:

Equivalent length
 = 14 feet (4.3 m) + (2) 90° elbows
 = 14 feet (4.3 m) + 7 feet (2.1 m) + 7 feet (2.1 m)
 = 28 feet (8.5 m)

With tumbler in operation, airflow at any point in duct must be at least 1200 feet (366 m) per minute to insure that lint remains airborne.

• **Collector Venting**

While it is preferable to exhaust tumblers individually to outdoors, a main collector duct may be used if it is sized according to *Figure 3.*

NOTE: This illustration indicates minimum diameters, and should be increased if collector length exceeds 20 feet (6.1 m).

Collector duct may be rectangular in cross section, as long as area is not reduced. Provisions should be made for lint removal and cleaning of collector duct.

Collector duct must be tapered, as shown in *Figure 3.* Individual tumbler ducts must enter the collector duct at a 45° angle in direction of air flow. **Never connect a tumbler duct at a 90° angle to collector duct. Doing so will cause excessive back pressure, resulting in poor performance. Never connect two tumbler exhaust ducts directly across from each other at point of entry to collector duct.**

Collector system must be designed so static back pressure measured 12 inches (30.5 cm) from exhaust thimble does not exceed maximum allowable pressure specified on installation sticker on rear of tumbler. Measured with all tumblers running that are vented into collector.

MAKE-UP AIR

A tumbler is forced air exhausted and requires provisions for make-up air to replace the air exhausted by tumbler.

Manufacturer's recommended make-up air opening for each tumbler is 144 square inches (928 sq. cm) for 30 and 50 pound tumblers and 195 square inches (1258 sq. cm) for 75 pound tumblers. **At a minimum, tumblers must have at least 1 in² (2.54 cm²) of opening for every 1000 BTU/hr (252 Kcal/hr) of input rating for proper combustion.**

Example: A tumbler with a rated input of 120,000 BTU/hr (30,240 Kcal) requires 120 in² (774 cm²) of free opening.

Protective louvers in opening to outdoors can reduce air movement by approximately 40%. Opening must compensate for area taken up by louvers.

Make-up air openings for a room containing tumbler(s) and/or gas fired hot water heater or other gravity vented appliances must be increased sufficiently to prevent downdrafts in any vents when all tumblers are in operation. Do not locate gravity vented appliances between tumbler(s) and make-up air openings. If it is necessary to duct make-up air to tumbler(s), increase area of work by 25% to compensate for any restriction in air movement.

⚠ WARNING

Solvent gases and vapors from dry cleaning machines create acids when drawn through the heater of a drying tumbler. These acids are corrosive to the drying tumbler as well as to the laundry load being dried. Be sure make-up air is free of solvent gases and vapors.

If the dry cleaning machines are in the same area as the tumbler, then the tumbler make-up air must come from a source free of solvent gases and vapors.

⚠ WARNING

To reduce the risk of fire and accumulation of combustible gases, **DO NOT** exhaust tumbler air into a window well, gas vent, chimney or enclosed, unventilated area such as an attic wall, ceiling, crawl space under a building, or concealed space of a building.

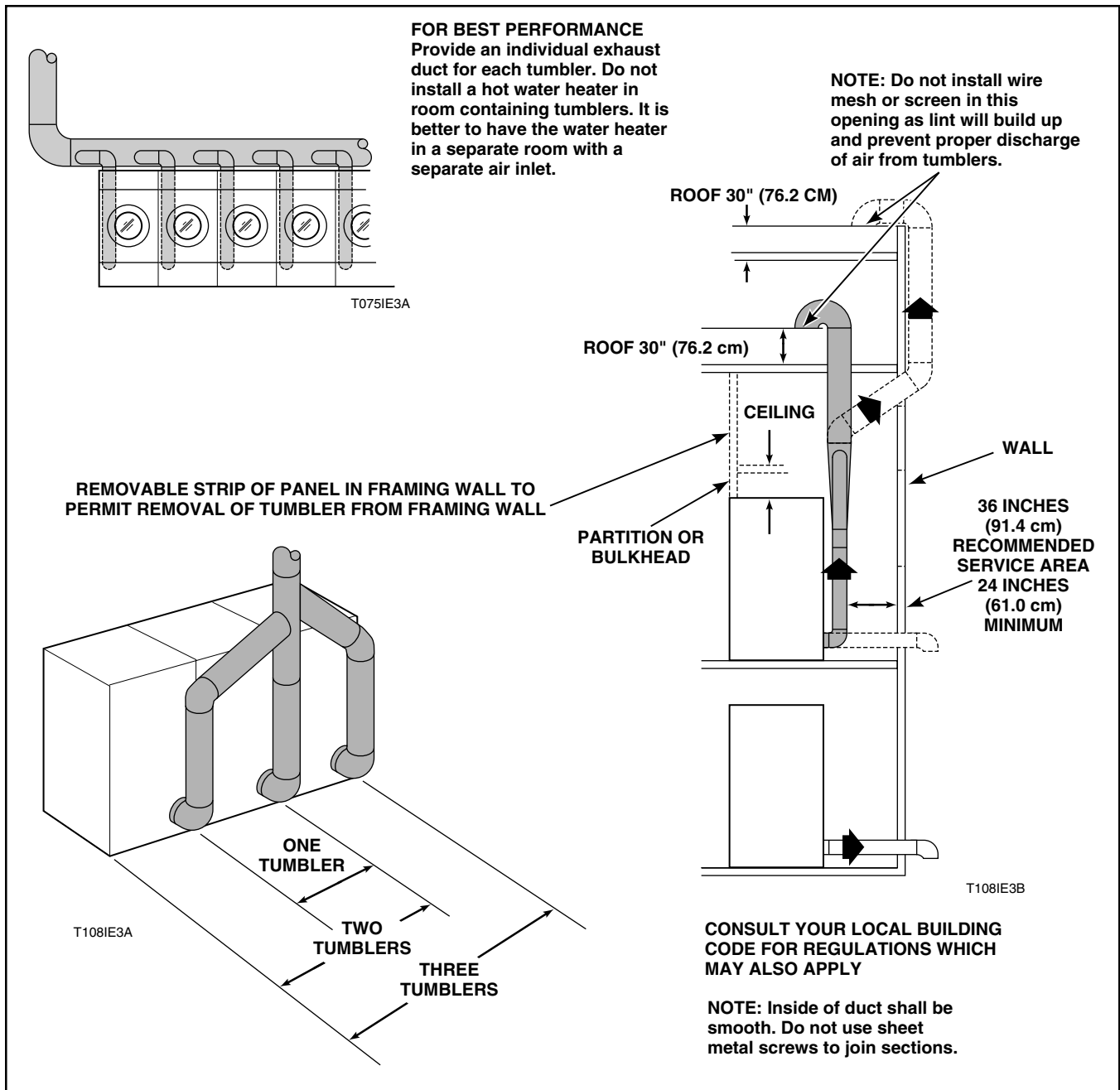

Figure 1

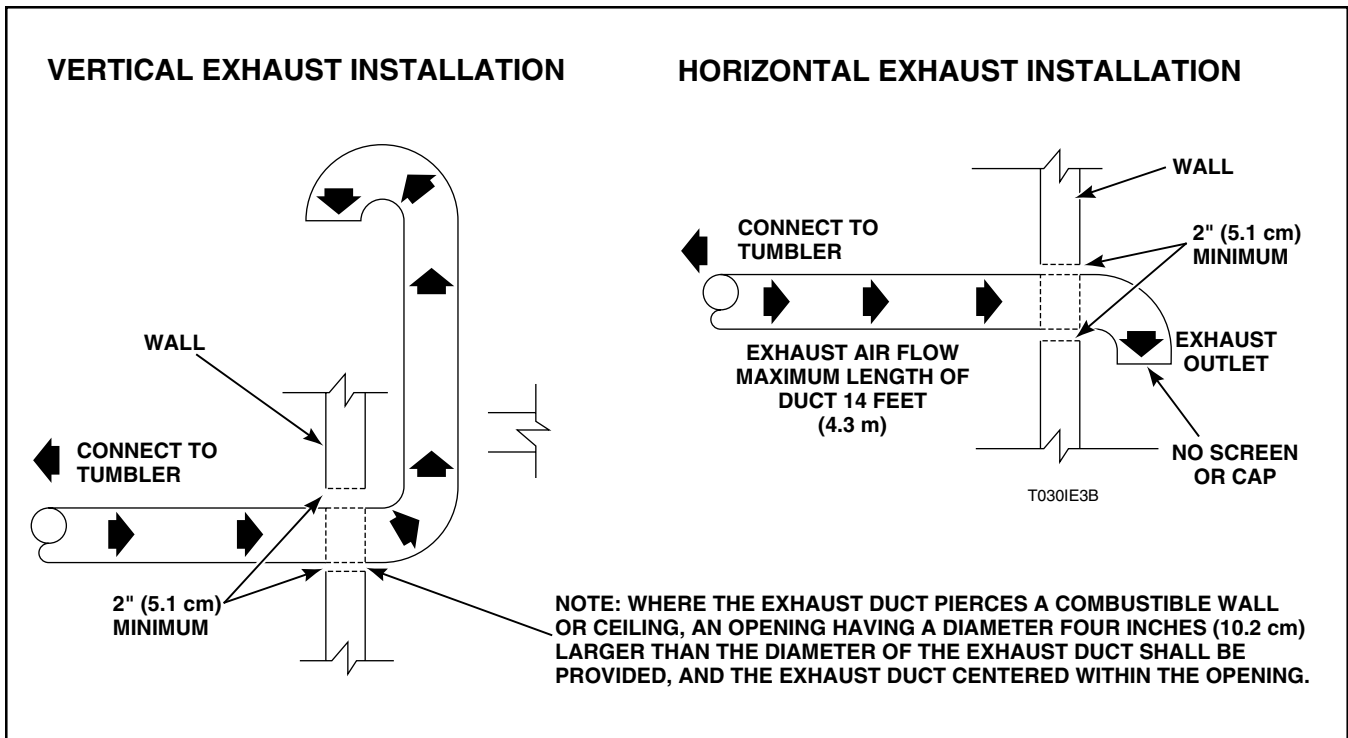

Figure 2

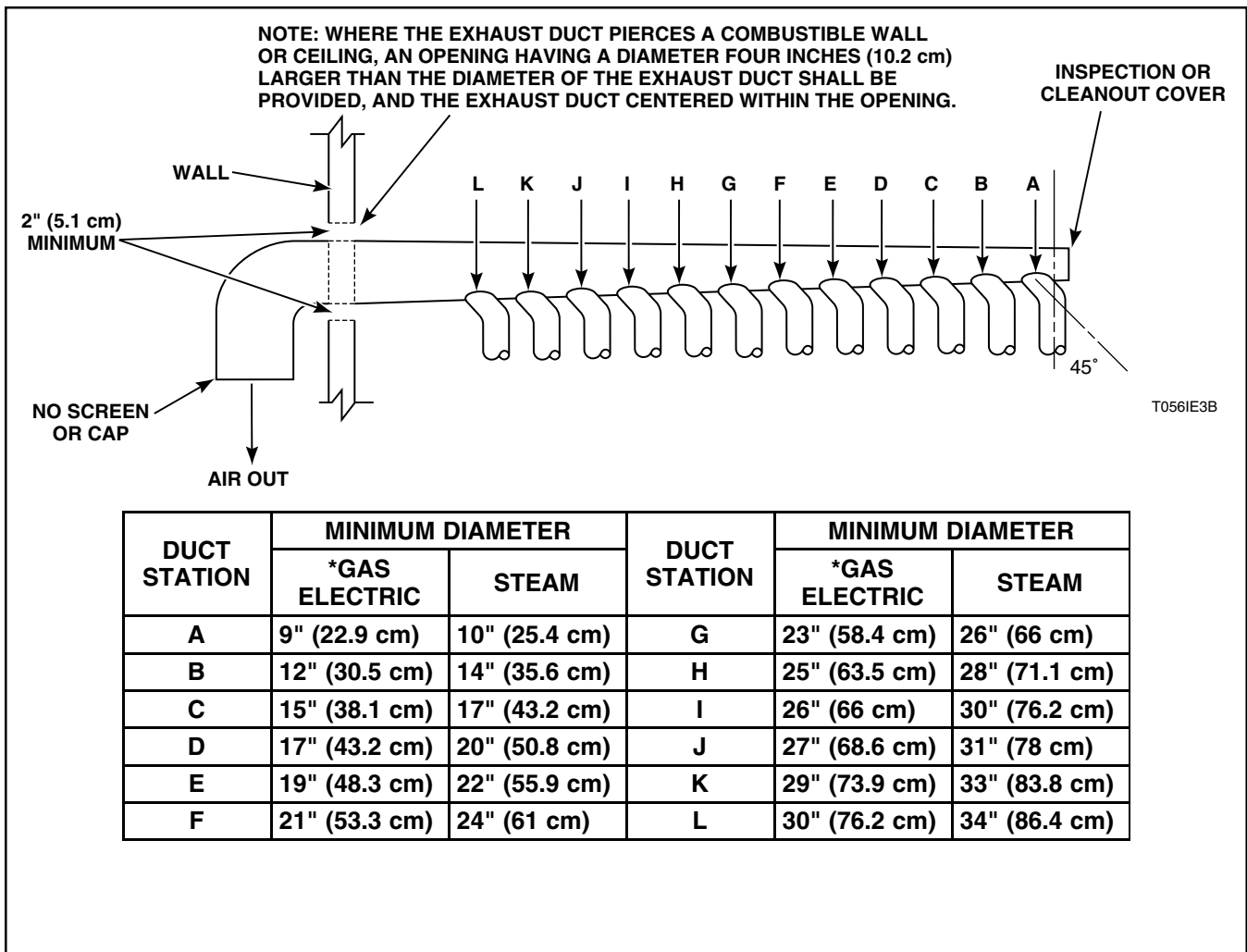

Figure 3

ELECTRICAL REQUIREMENTS

For 30 Pound (13 kg) Narrow Cabinet Tumblers

REQUIREMENTS

Heat Source	Electrical Specs	Wires Required and Terminal Block Connection			
Gas	230-50-1	L1	L2		Ground to PE Busbar
Electric	230-50-1	L1	L2		Ground to PE Busbar
Electric	230-50-3	L1	L2	L3	Ground to PE Busbar
Electric	380-50-3	L1	L2	L3	Ground to PE Busbar
Electric	415-50-3	L1	L2	L3	Ground to PE Busbar

Figure 4

GAS DRYING TUMBLERS

GAS DRYING TUMBLERS		
	240V, 1 Phase, 50 Hz.	120V, 1 Phase, 30 Hz.
Minimum Wire Size	14 AWG (2.081 mm ²)	14 AWG (2.081 mm ²)
Circuit Breaker	15 AMP	15 AMP
No. of Poles	2	2

Figure 5

ELECTRIC DRYING TUMBLERS

ELECTRIC DRYING TUMBLERS				
	240V 50 Hz. 1 Ph	240V 50 Hz. 3 Ph	380V 50 Hz. 3 Ph	415V 50 Hz. 3 Ph
Amp Rating	91 Amp	55 Amp	34 Amp	31 Amp
Circuit Breaker	100 Amp	60 Amp	40 Amp	35 Amp
Poles	2	3	3	3
Minimum Wire Size	2 AWG (33.63 mm ²)	6 AWG (13.32 mm ²)	8 AWG (8.366 mm ²)	8 AWG (8.366 mm ²)

Figure 6

GROUNDING INSTRUCTIONS

Drying tumbler must be grounded. In event of malfunction or breakdown, grounding will reduce risk of electric shock by providing a path of least resistance for electric current. Drying tumbler must be connected to a grounded metal, permanent wiring system; or an equipment grounding conductor must be run with circuit conductors and connected to PE Busbar.

⚠ WARNING

To reduce the risk of fire and electric shock, check with a qualified serviceman for proper grounding procedures. Improper connection of the equipment grounding conductor can result in a risk of electric shock.

⚠ WARNING

To reduce the risk of fire and electric shock, if electrical supply is coming from a three phase service, DO NOT connect a "Stinger Leg" to a single phase machine.

ELECTRICAL REQUIREMENTS

For 30 Pound (13 kg) Tumblers

REQUIREMENTS

Heat Source	Electrical Specs	Wires Required and Terminal Block Connection			
		L1	L2	L3	Ground to PE Busbar
Gas & Steam	230/50/1	L1	L2		Ground to PE Busbar
Electric	230/50/1	L1	L2		Ground to PE Busbar
Electric	380/50/3	L1	L2	L3	Ground to PE Busbar
Electric	415/50/3	L1	L2	L3	Ground to PE Busbar
Steam	380/50/3	L1	L2	L3	Ground to PE Busbar

Figure 7

GAS AND HIGH PRESSURE STEAM DRYING TUMBLERS

GAS AND HIGH PRESSURE STEAM DRYING TUMBLERS		
	240 V, 1 Phase, 50 Hz.	380 V, 3 Phase, 50 Hz.
Minimum Wire Size	14 AWG (2.081 mm ²)	14 AWG (2.081 mm ²)
Circuit Breaker	15 AMP	15 AMP
Poles	2	2

Figure 8

ELECTRIC DRYING TUMBLERS

NOTE: DO NOT use aluminum wire.

ELECTRIC DRYING TUMBLERS				
	240 V, 1 Ph, 50 Hz.	240 V, 3 Ph, 50 Hz.	380 V, 3 Ph, 50 Hz.	415 V, 3 Ph, 50 Hz.
Minimum Wire Size	2 AWG (33.63 mm ²)	6 AWG (13.32 mm ²)	8 AWG (8.366 mm ²)	8 AWG (8.366 mm ²)
AMP Rating	90 Amp	54 Amp	33 Amp	30 Amp
Circuit Breaker	100 Amp	60 Amp	40 Amp	35 Amp
Poles	2	3	3	3

Figure 9

30 Pound (13 kg) Tumblers

LOW STEAM DRYING TUMBLERS

LOW PRESSURE STEAM DRYING TUMBLERS	
	240 V, 1 Phase 50 Hz.
Minimum Wire Size	16 AWG (1.309 mm ²)
Circuit Breaker	20 AMP
Poles	2

Figure 10

GROUNDING INSTRUCTIONS

Drying tumbler must be grounded. In event of malfunction or breakdown, grounding will reduce risk of electric shock by providing a path of least resistance for electric current. Drying tumbler must be connected to a grounded metal, permanent wiring system; or an equipment grounding conductor must be run with circuit conductors and connected to PE Busbar.

⚠ WARNING

To reduce the risk of fire and electric shock, check with a qualified serviceman for proper grounding procedures. Improper connection of the equipment grounding conductor may result in a risk of electric shock.

⚠ WARNING

To reduce the risk of fire and electric shock, if electrical supply is coming from a three phase service, DO NOT connect a “Stinger Leg” to a single phase machine.

ELECTRICAL REQUIREMENTS

For 50 Pound (22 kg) Tumblers

REQUIREMENTS

Heat Source	Electrical Specs	Wires Required and Terminal Block Connection			
Non-Reversing Models					
Gas & Steam	230/50/1	L1	L2		Ground to PE Busbar
Steam	380-415/50/3	L1	L2	L3	Ground to PE Busbar
Electric	230/50/1	L1	L2		Ground to PE Busbar
Electric	380-415/50/3	L1	L2	L3	Ground to PE Busbar
Reversing Models					
Gas & Steam	230/50/1	L1	L2		Ground to PE Busbar
Gas & Steam	380-415/50/3	L1	L2	L3	Ground to PE Busbar
Electric	230/50/3	L1	L2	L3	Ground to PE Busbar
Electric	380-415/50/3	L1	L2	L3	Ground to PE Busbar

Figure 11

GAS AND HIGH PRESSURE STEAM DRYING TUMBLER

GAS AND HIGH PRESSURE STEAM DRYING TUMBLERS			
	208V / 240 V 1 Phase, 50 Hz.	208 / 240 V 3 Phase, 50 Hz.	380 / 415 V 3 Phase, 50 Hz.
Minimum Wire Size	14 AWG (2.081 mm ²)	14 AWG (2.081 mm ²)	14 AWG (2.081 mm ²)
Circuit Breaker	15 AMP	15 AMP	15 AMP
Poles	2	3	3

Figure 12

ELECTRIC DRYING TUMBLERS

NOTE: DO NOT use aluminum wire.

ELECTRIC DRYING TUMBLERS			
	240 V, 3 Phase 50 Hz.	380 V, 3 Phase 50 Hz.	415 V, 3 Phase 50 Hz.
Minimum Wire Size	3 AWG (26.67 mm ²)	6 AWG (13.32 mm ²)	6 AWG (13.32 mm ²)
AMP Rating	78 AMP	48 AMP	45 AMP
Circuit Breaker	80 AMP	50 AMP	50 AMP
Poles	3	3	3

Figure 13

50 Pound (22 kg) Tumblers

LOW PRESSURE STEAM DRYING TUMBLERS

LOW PRESSURE STEAM DRYING TUMBLERS	
	240 V 1 Phase, 50 Hz.
Minimum Wire Size	14 AWG (2.081 mm ²)
Circuit Breaker	15 AMP
Poles	2

Figure 14

GROUNDING INSTRUCTIONS

Drying tumbler must be grounded. In event of malfunction or breakdown, grounding will reduce risk of electric shock by providing a path of least resistance for electric current. Drying tumbler must be connected to a grounded metal, permanent wiring system; or an equipment grounding conductor must be run with circuit conductors and connected to the PE Busbar.

⚠ WARNING

To reduce the risk of fire and electric shock, check with a qualified service technician for proper grounding procedures. Improper connection of the equipment grounding conductor can result in a risk of electric shock.

⚠ WARNING

To reduce the risk of fire and electric shock, if electrical supply is coming from a three phase service, DO NOT connect a “Stinger Leg” to a single phase machine.

ELECTRICAL REQUIREMENTS

For 75 Pound (34 kg) Tumblers

REQUIREMENTS

Heat Source	Electrical Specs	Wires Required and Terminal Block Connection			
Gas & Steam	230/50/1	L1	L2		Ground to PE Busbar
Electric	208-230/50-60/3	L1	L2	L3	Ground to PE Busbar
Electric	380/50/3	L1	L2	L3	Ground to PE Busbar
Electric	415/50/3	L1	L2	L3	Ground to PE Busbar
Steam	380/50/3	L1	L2	L3	Ground to PE Busbar

Figure 15

GAS AND HIGH PRESSURE STEAM DRYING TUMBLERS

GAS AND HIGH PRESSURE STEAM DRYING TUMBLERS			
	208V / 240 V 1 Phase, 50 Hz.	208 / 240 V 3 Phase, 50 Hz.	380 / 415 V 3 Phase, 50 Hz.
Minimum Wire Size	14 AWG (2.081 mm ²)	14 AWG (2.081 mm ²)	14 AWG (2.081 mm ²)
Circuit Breaker	15 AMP	15 AMP	15 AMP
Poles	2	3	3

Figure 16

ELECTRIC DRYING TUMBLERS

NOTE: DO NOT use aluminum wire.

ELECTRIC DRYING TUMBLERS		
	380 V, 3 Ph, 50 Hz.	415 V, 3 Ph, 50 Hz.
Minimum Wire Size	6 AWG (13.32 mm ²)	6 AWG (13.32 mm ²)
AMP Rating	48 Amp	45 Amp
Circuit Breaker	50 Amp	50 Amp
Poles	3	3

Figure 17

GROUNDING INSTRUCTIONS

Drying tumbler must be grounded. In event of malfunction or breakdown. Grounding will reduce risk of electric shock by providing a path of least resistance for electric current. Drying tumbler must be connected to a grounded metal, permanent wiring system; or an equipment grounding conductor must be run with circuit conductors and connected to PE Busbar.

⚠ WARNING

To reduce the risk of fire and electric shock, check with a qualified service technician for proper ground procedures. Improper connection of the equipment grounding conductor may result in risk of electric shock.

⚠ WARNING

To reduce the risk of fire and electric shock, if electrical supply is coming from a three phase service, DO NOT connect a "Stinger Leg" to a single phase machine.

ELECTRICAL CONNECTIONS

⚠ WARNING

All electrical connections should be made by a qualified electrician.

To reduce the risk of electrical shock, de-energize the electrical circuit being connected to the tumbler before making any electrical connections. Never attempt to connect a live circuit.

Use the following steps to connect electrical service to the tumbler:

1. Install a circuit breaker, as close to tumbler as possible. If more than one tumbler is being installed, a circuit breaker should be provided for each tumbler. This will make it possible to disconnect each tumbler for maintenance purposes.
2.
 - a. Connect conduit-encased leads to circuit breaker.
 - b. Turn "off" disconnect switch on tumbler and open junction box.
 - c. Insert conduit-encased leads through one of the knockout holes in junction box.
 - d. Connect wire leads to disconnect switch.

1 Phase Units: Connect one lead to top left connection point. Connect other lead to top right connection point.

3 Phase Units: Connect one lead to each connection point.

- e. Connect a ground wire to PE Busbar, *Figure 19*, in junction box.

3. Check electrical service phase sequence (three phase only) as follows:
 - a. Energize electrical service and momentarily start tumbler. Check direction of the cylinder rotation. If cylinder rotates clockwise (viewed from front), phase sequence is correct. If cylinder rotates counterclockwise, proceed with step "b".
 - b. Disconnect and reverse any two leads at connections.
4. Close junction box cover and turn "on" disconnect switch.

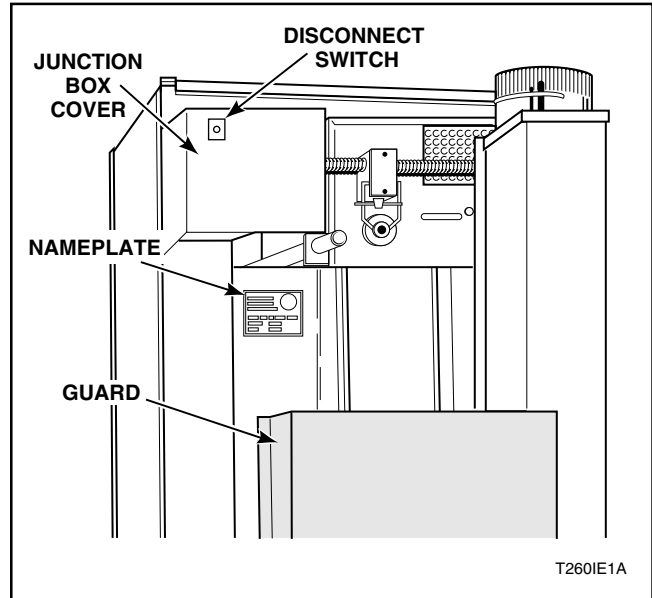

Figure 18

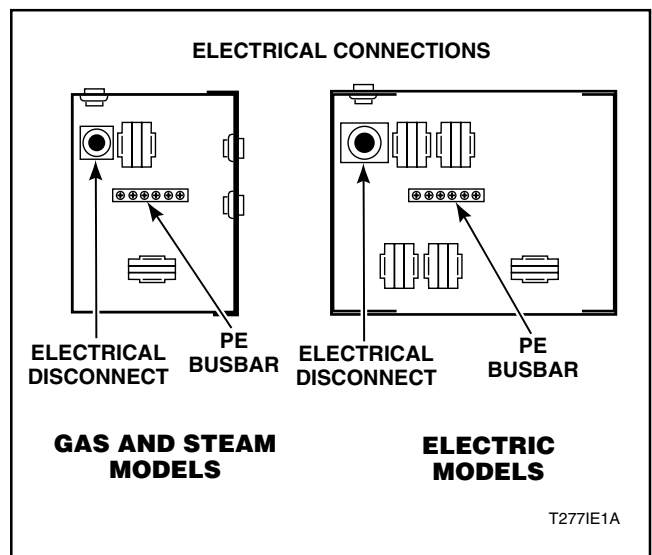

Figure 19

POSITIONING DRYING TUMBLER

Tumbler may be removed from skid before moving to installation location or moved while still attached to skid. Remove tumbler from skid by unscrewing four shipping capscrews (one at each corner) and remove tumbler from skid. Lint panel door will have to be removed in order to remove two front capscrews.

Screw four leveling legs back into level adjusting fittings from top. Slide tumbler to its permanent location and level. Keep tumbler as close to floor as possible. All four legs must rest firmly on floor so weight of tumbler is evenly distributed. Tumbler must not rock.

NOTE: Do not throw these four capscrews away — they are the leveling legs.

LEVELING DRYING TUMBLER

Each tumbler should be leveled within $\frac{1}{8}$ inch (3.2 mm) from front to rear, and $\frac{1}{8}$ inch (3.2 mm) from side to side. Check front to rear level by rotating clothes cylinder until one rib is at bottom, then place a

level on bottom rib. Side to side level should be checked by placing a level on front and rear of top panel.

GAS REQUIREMENTS (Gas Drying Tumblers)

Size of gas service pipe is dependent upon many variables (lengths, tees, etc.). Specific pipe size information should be obtained from gas supplier. Refer to table in *Figure 22* for general pipe size data.

It is important that equal gas pressure be maintained at all tumbler gas connections. This can best be done by installing a one inch pipe gas loop as shown in *Figures 20 and 21*.

⚠ WARNING

To reduce the risk of fire or explosion, if the tumbler is to be connected to Liquefied Petroleum (L.P.) gas, a vent to the outdoors must be provided in the room where the tumbler is installed.

Example of Gas Loop Piping

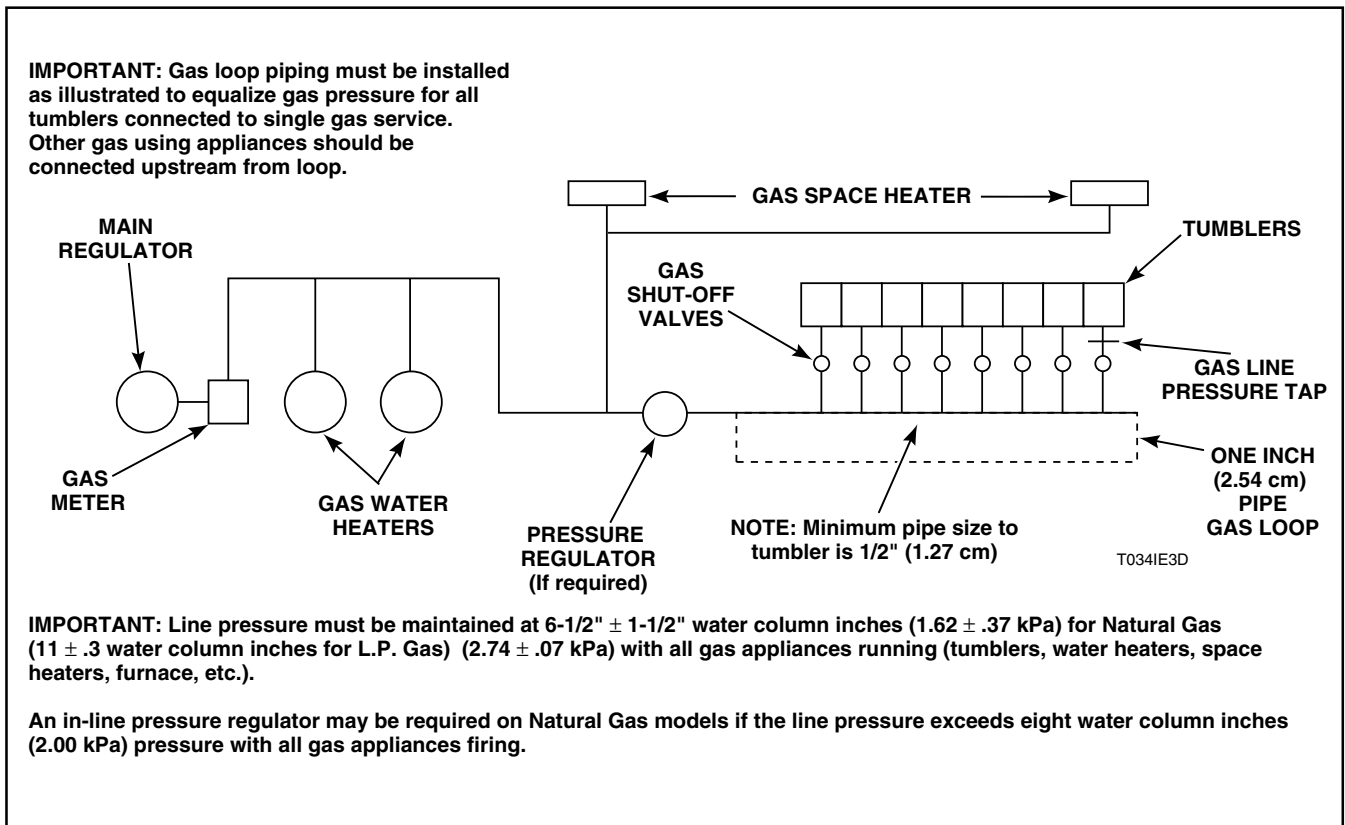

Figure 20

Example of Gas Supply Piping

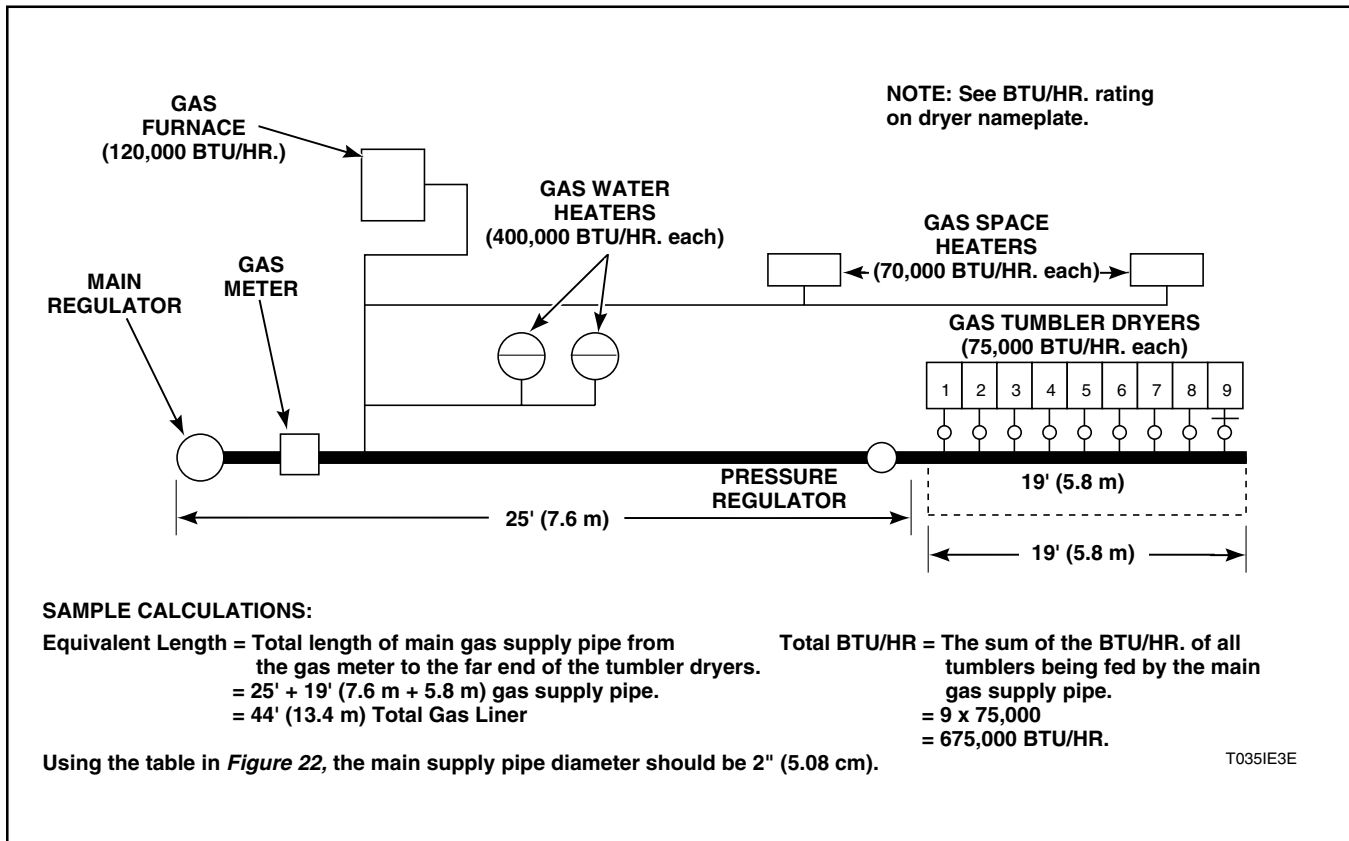

Figure 21

**GAS PIPE SIZE REQUIRED FOR 1,000 BTU NATURAL GAS — .64 SPECIFIC GRAVITY
AT 6½ ± 1½ INCH WATER COLUMN PRESSURE (1.62 ± .37 kPa)**

GAS APPLIANCES TOTAL BTU/HR. (Kcal/hr)		EQUIVALENT LENGTH					
		25 FT. (7.63 m)	50 FT. (15.25 m)	75 FT. (22.88 m)	100 FT. (30.50 m)	125 FT. (38.13 m)	150 FT. (45.75 m)
		BASED ON 0.3" WATER COLUMN (0.75 mBar) PRESSURE DROP FOR LENGTH GIVEN					
100,000 (25,200)	¾" (1.905cm)	¾" (1.905cm)	1" (2.54cm)	1" (2.54cm)	1" (2.54cm)	1" (2.54cm)	
120,000 (30,240)	¾" (1.905cm)	1" (2.54cm)	1" (2.54cm)	1" (2.54cm)	1" (2.54cm)	1" (2.54cm)	
140,000 (35,280)	¾" (1.905cm)	1" (2.54cm)	1" (2.54cm)	1" (2.54cm)	1" (2.54cm)	1¼" (3.18cm)	
160,000 (40,320)	¾" (1.905cm)	1" (2.54cm)	1" (2.54cm)	1¼" (3.18cm)	1¼" (3.18cm)	1¼" (3.18cm)	
180,000 (45,360)	1" (2.54cm)	1" (2.54cm)	1" (2.54cm)	1¼" (3.18cm)	1¼" (3.18cm)	1¼" (3.18cm)	
200,000 (50,400)	1" (2.54cm)	1" (2.54cm)	1¼" (3.18cm)	1¼" (3.18cm)	1¼" (3.18cm)	1½" (3.81cm)	
300,000 (75,600)	1" (2.54cm)	1¼" (3.18cm)	1¼" (3.18cm)	1½" (3.81cm)	1½" (3.81cm)	1½" (3.81cm)	
400,000 (100,800)	1¼" (3.18cm)	1¼" (3.18cm)	1½" (3.81cm)	1½" (3.81cm)	1½" (3.81cm)	2" (5.08cm)	
500,000 (126,000)	1¼" (3.18cm)	1½" (3.81cm)	1½" (3.81cm)	2" (5.08cm)	2" (5.08cm)	2" (5.08cm)	
600,000 (151,200)	1½" (3.81cm)	1½" (3.81cm)	2" (5.08cm)	2" (5.08cm)	2" (5.08cm)	2" (5.08cm)	
700,000 (176,400)	1½" (3.81cm)	2" (5.08cm)	2" (5.08cm)	2" (5.08cm)	2" (5.08cm)	2½" (6.35cm)	
800,000 (201,600)	1½" (3.81cm)	2" (5.08cm)	2" (5.08cm)	2" (5.08cm)	2½" (6.35cm)	2½" (6.35cm)	
900,000 (226,800)	2" (5.08cm)	2" (5.08cm)	2" (5.08cm)	2½" (6.35cm)	2½" (6.35cm)	2½" (6.35cm)	
1,000,000 (252,000)	2" (5.08cm)	2" (5.08cm)	2" (5.08cm)	2½" (6.35cm)	2½" (6.35cm)	2½" (6.35cm)	
1,100,000 (277,200)	2" (5.08cm)	2" (5.08cm)	2½" (6.35cm)	2½" (6.35cm)	2½" (6.35cm)	2½" (6.35cm)	
1,200,000 (302,400)	2" (5.08cm)	2" (5.08cm)	2½" (6.35cm)	2½" (6.35cm)	2½" (6.35cm)	2½" (6.35cm)	
1,300,000 (327,600)	2" (5.08cm)	2½" (6.35cm)	2½" (6.35cm)	2½" (6.35cm)	2½" (6.35cm)	3" (7.62cm)	
1,400,000 (352,800)	2" (5.08cm)	2½" (6.35cm)	2½" (6.35cm)	2½" (6.35cm)	3" (7.62cm)	3" (7.62cm)	
1,500,000 (378,600)	2" (5.08cm)	2½" (6.35cm)	2½" (6.35cm)	2½" (6.35cm)	3" (7.62cm)	3" (7.62cm)	
1,600,000 (403,200)	2" (5.08cm)	2½" (6.35cm)	2½" (6.35cm)	3" (7.62cm)	3" (7.62cm)	3" (7.62cm)	
1,700,000 (428,400)	2" (5.08cm)	2½" (6.35cm)	2½" (6.35cm)	3" (7.62cm)	3" (7.62cm)	3" (7.62cm)	
1,800,000 (453,600)	2½" (6.35cm)	2½" (6.35cm)	3" (7.62cm)	3" (7.62cm)	3" (7.62cm)	3" (7.62cm)	
1,900,000 (478,800)	2½" (6.35cm)	2½" (6.35cm)	3" (7.62cm)	3" (7.62cm)	3" (7.62cm)	3" (7.62cm)	
2,000,000 (504,000)	2½" (6.35cm)	2½" (6.35cm)	3" (7.62cm)	3" (7.62cm)	3" (7.62cm)	3½" (8.89cm)	
2,200,000 (554,400)	2½" (6.35cm)	3" (7.62cm)	3" (7.62cm)	3" (7.62cm)	3½" (8.89cm)	3½" (8.89cm)	
2,400,000 (604,800)	2½" (6.35cm)	3" (7.62cm)	3" (7.62cm)	3" (7.62cm)	3½" (8.89cm)	3½" (8.89cm)	
2,600,000 (655,200)	2½" (6.35cm)	3" (7.62cm)	3" (7.62cm)	3½" (8.89cm)	3½" (8.89cm)	3½" (8.89cm)	
2,800,000 (705,600)	2½" (6.35cm)	3" (7.62cm)	3" (7.62cm)	3½" (8.89cm)	3½" (8.89cm)	3½" (8.89cm)	
3,000,000 (756,000)	2½" (6.35cm)	3" (7.62cm)	3½" (8.89cm)	3½" (8.89cm)	3½" (8.89cm)	4" (10.16cm)	

Figure 22

GAS CONNECTIONS (Gas Drying Tumblers)

Before connecting gas piping to tumbler, make certain gas service is same as that specified on nameplate (near gas connection), Page 5.

NATURAL GAS service must be supplied at $6\frac{1}{2} \pm 1\frac{1}{2}$ inch water column pressure ($1.62 \pm .37$ kPa).

L.P. GAS service must be supplied at $11 \pm .3$ inch water column pressure ($2.74 \pm .07$ kPa).

If gas service is not same as that specified, DO NOT CONNECT THE GAS LINE TO TUMBLER! It will first be necessary to convert gas burner orifice and gas valve.

IMPORTANT: Any product revisions or conversions must be made by the Manufacturer's Authorized Dealers, Distributors or local service personnel.

Purge air and sediment from gas service line before connecting it loosely to tumbler. Purge remaining air until odor of gas is detected, then tighten connection. **Use pipe compound, resistant to actions of L.P. gas, on all pipe threads.**

▲ WARNING

Check all pipe connections, internal and external, for gas leaks using a soapy solution. To reduce the risk of explosion or fire, DO NOT USE AN OPEN FLAME TO CHECK FOR GAS LEAKS! Gas connections should be checked annually for leakage.

▲ WARNING

The tumbler and its individual shut-off valve must be disconnected from the gas supply piping system during any pressure testing of that system at test pressures in excess of 1/2 psig (3.45 kPa).

The tumbler must be isolated from the gas supply piping system by closing its individual manual shut-off valve during any pressure testing of the gas supply piping system at test pressure equal to or less than 1/2 psig (3.45 kPa).

DRYING TUMBLER ENCLOSURE CONSTRUCTION

IMPORTANT: DO NOT block airflow at top rear of tumbler with laundry, etc. Doing so would prevent adequate air supply to tumbler's heat chamber.

A typical tumbler enclosure is shown in *Figure 23*. Note that enclosure does touch tumbler top and side panels. Note, too, minimum and maximum dimensions. Be aware that there may be local codes and ordinances which must be complied with.

⚠ WARNING

To reduce the risk of serious injury, install lockable doors to prevent public access to rear of tumblers.

IMPORTANT: Install tumblers with sufficient clearance for servicing and operating, see *Figure 23*.

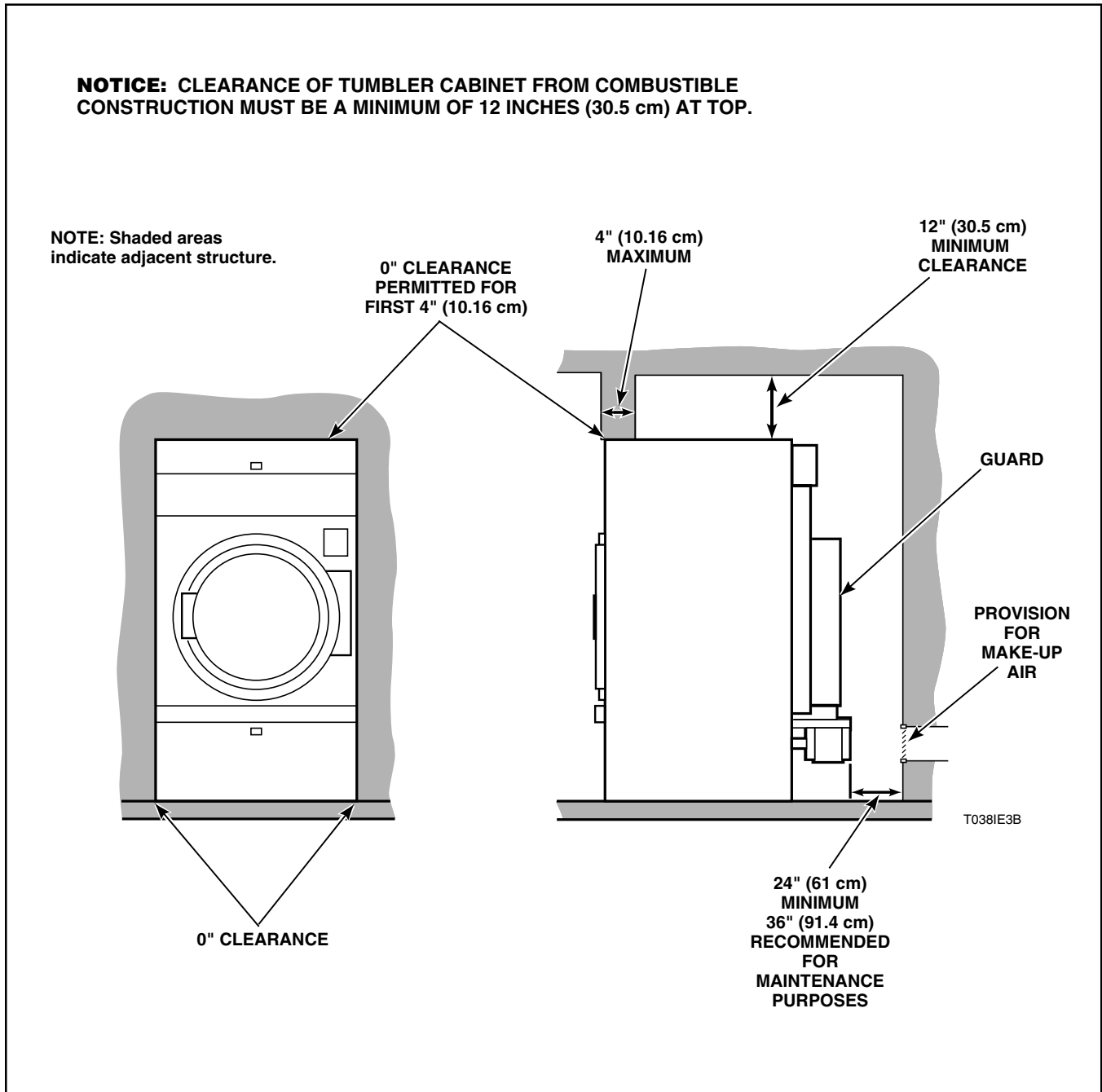

Figure 23

STEAM REQUIREMENTS (Steam Drying Tumblers) _____

Size of steam service pipe is dependent upon many variables (length, tees, high pressure system, low pressure system, etc.) Specific pipe size

information should be obtained from the steam system supplier or a qualified steam fitter.

STEAM CONNECTIONS (Steam Drying Tumblers) _____

INSTALLING STEAM SOLENOID VALVE AND MAKING STEAM INLET CONNECTIONS

High pressure machines require a (constant) 80 to 100 psig (5.62 to 7.03 kg/sq. cm) steam service for optimum operation. Low pressure machines require a (constant) 10 to 15 psig (.70 to 1.05 kg/sq. cm) steam service for optimum operation. The following steps outline procedure for installing steam solenoid valve and connecting steam service.

- a. Install a manual shut-off gate valve in condensate return line after steam trap for each coil.
- b. Connect steam solenoid valve to related steam coil inlet connection with nipples, flex hoses, unions, tee and pressure relief valve. See *Figure 24* for a typical installation.
- c. Install a gate shut-off valve in steam supply line, *Figure 24*. Connect shut-off gate valve outlet to solenoid steam valve inlet connection.

▲WARNING

The flexible steam hoses connecting the solenoid steam valve to the coil inlets must have a 125 psig (pounds per square inch gauge) (8.79 kg/sq. cm) working pressure. A shut-off gate valve must be installed upstream from the solenoid steam valve. This way, steam can be shut off for maintenance purposes, or in the event the hose ruptures.

The steam solenoid valve must be supported so minimum load is exerted on the steam coil inlet connections.

INSTALLING STEAM TRAP AND MAKING CONDENSATE RETURN CONNECTIONS

Steam trap must be installed and coil outlet connections must be connected to condensate return lines. The following steps outline the procedure for installing steam trap and connecting condensate return lines. See *Figure 24* for a typical installation.

- a. Connect a flexible hose to each steam coil outlet, *Figure 24*.
- b. Install a strainer to the ends of each flexible hose.
- c. Install a steam trap to each strainer.

IMPORTANT: Steam trap must be installed a minimum of 10 inches (25.4 cm) below steam coil outlet connections, see *Figure 24*.

- d. Install a gate shut-off valve to each steam trap.
- e. Connect to condensate return lines.

▲WARNING

The flexible steam hoses connecting the coil outlet connections and steam traps must have a minimum of 125 psig (pounds per square inch gauge) (8.79 kg/sq. cm.) working pressure. A shutoff gate valve must be installed downstream from each steam trap so the condensate return line can be isolated in event a steam trap requires maintenance.

Each steam trap must be supported so minimum load is exerted on the coil outlet connection.

STEAM CONNECTIONS (Steam Drying Tumblers)

NOTE: See *Figure 25* for sizing of steam lines. Piping must also be sized accordingly for length of runs, and number of elbows.

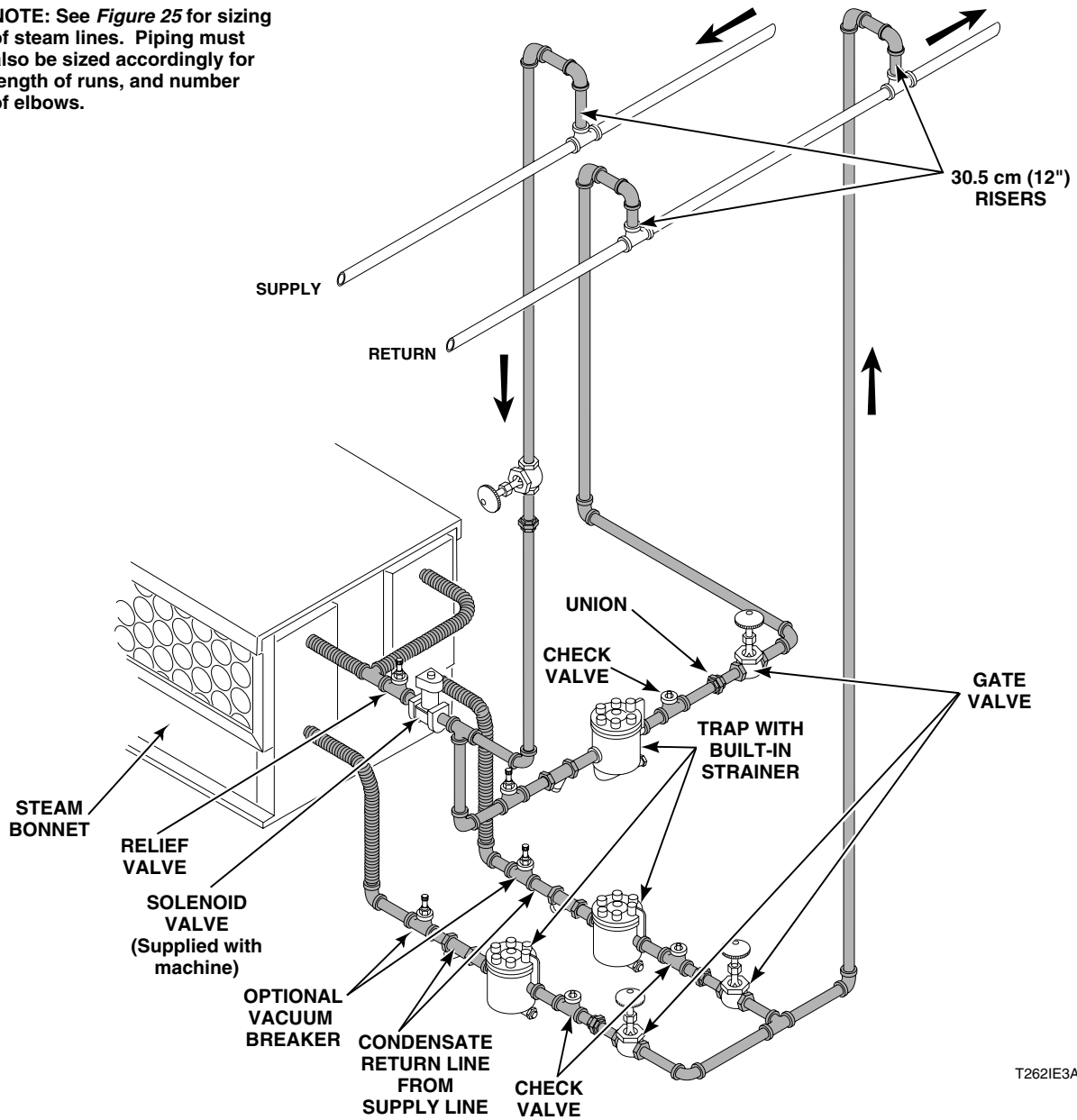

T2621E3A

Figure 24

TUMBLER MODEL	STEAM PRESSURE (PSI)	MINIMUM PIPE DIAMETER	STEAM TRAP SIZE (Pounds Condensate/Hour)
30CSL	7-15	3/4" (1.9 cm)	140
30 CSH	80-100	3/4" (1.9 cm)	140
50 CSL	7-15	3/4" (1.9 cm)	140
50 CSH	80-100	3/4" (1.9 cm)	160
75 CSL	7-15	3/4" (1.9 cm)	140
75 CSH	80-100	3/4" (1.9 cm)	160

Figure 25

LIGHTING AND SHUTTING DOWN GAS IGNITION SYSTEM

1. Turn machine disconnect switch, located on rear of tumbler, to the "on" position.
2. Turn gas shut-off valve, located on rear of tumbler, to the "on" position (gas valve handle should be parallel with gas line).
3. Start tumbler, following operating instructions which accompanied it.

NOTE: Ignition control circuitry will verify airflow switch, located on rear of tumbler, is open before starting cylinder motor. Once cylinder motor is started, air flowing through tumbler will cause airflow switch to close. Tumbler will purge air from tumbler for 18 seconds. Ignition will start by a three second release of gas from gas valve and sparking of ignitor. If ignition does not occur

during first three seconds ignition control will "lockout" causing gas valve to close and a red button on ignition control to illuminate.

To reset ignition system , open access door and press red button on ignition control. Close and lock access door, verify that gas shut-off valve is in the "on" position and return to step three.

4. If tumbler will not start, remove it from service by turning machine disconnect switch, located on rear of tumbler, to the "off" position and turn the gas shut-off valve, located on rear of tumbler, to the "off" position (gas valve handle should be at a right angle to gas line).

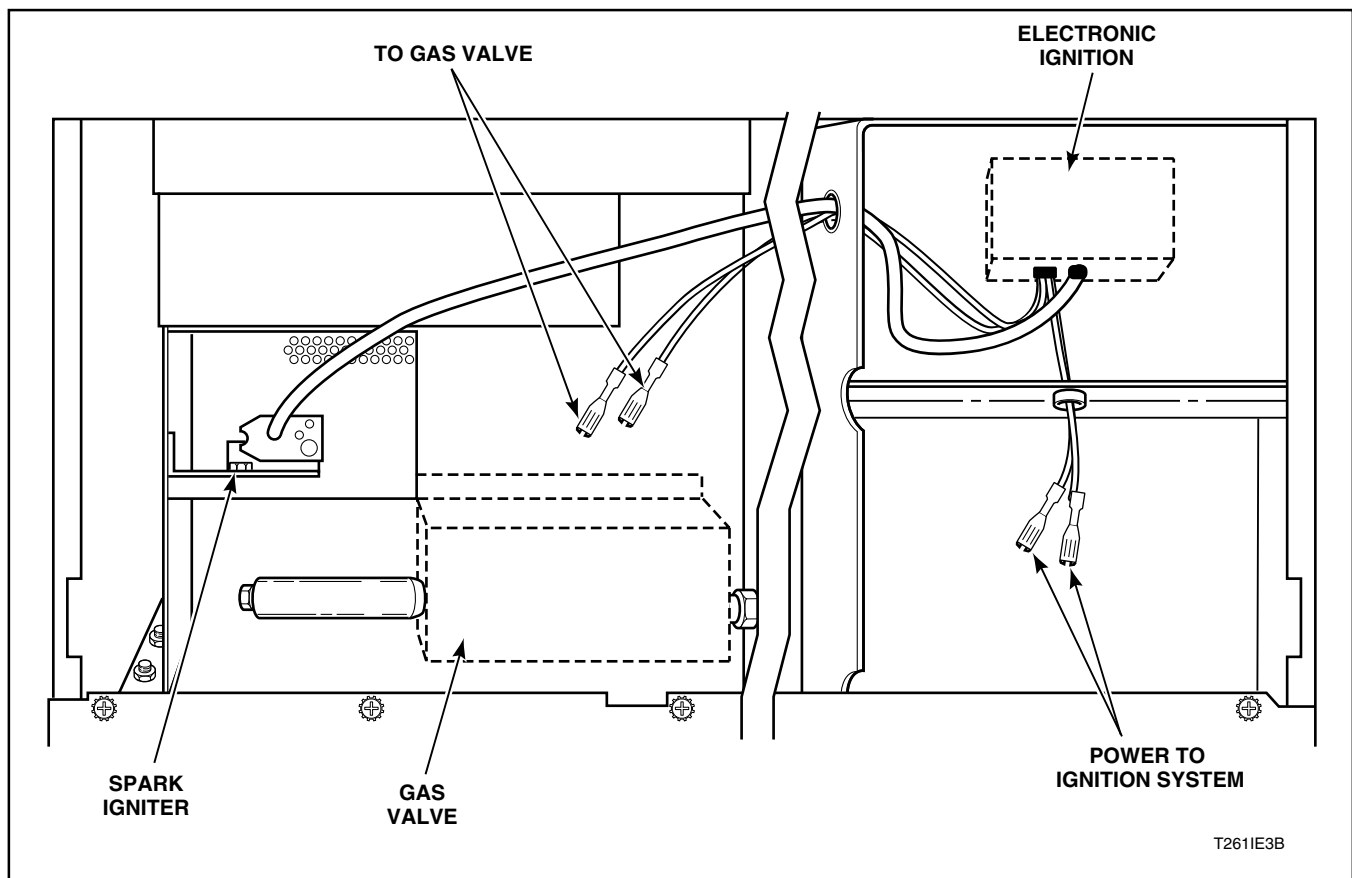

Figure 26

ACCESSORY TIMING CAM INSTALLATION

(Coin Meter Models)

No. of Pins in Cam	Cycle Length (Minutes)
6	10
5	12
4	15

Figure 27

Cams that allow other timer increments are available through your distributor.

To figure time increments, use this formula: Timer Motor Speed (60) divided by number of pins on cam = Cycle Length (minutes). Cams are available with 1 to 12 pins.

Example: $60 \div 5$ (Pin cam) = 12 minute cycle.

REMOVAL OF EXISTING TIMING CAM

1. Rotate cam by hand until "V" notch lines up beneath the ratchet tooth see *Figure 28*.
2. Insert narrow screwdriver under nylon cam, close to the clock shaft. Lift gently off shaft. Make sure that pressure is directed upward and that the "V" notch clears the ratchet tooth.

INSTALLATION OF NEW TIMING CAM

1. Insert drive into timing cam with wide prong in wide hole of cam.
2. Position timing cam and drive fork over the timer shaft, aligning the timer flat with the drive fork and the "V" notch with one of the ratchet teeth.
3. Press timing cam down firmly to seat timing cam onto the motor shaft.

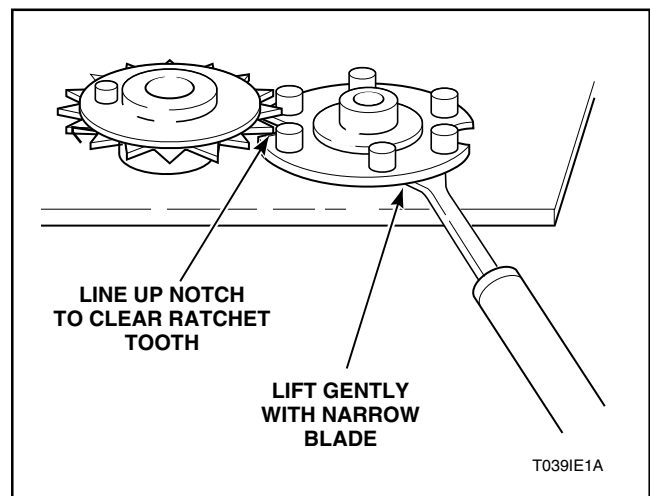

Figure 28

4. Remove all accumulated time by turning cam counterclockwise until switch shuts off. Apply moderate clockwise pressure to fully seated timing cam and drive against the timing motor shaft. Meter must be advanced electrically for one cycle before an accurate measure of time can be made.

PRELIMINARY OPERATING CHECKS

1. Remove or open all panels and inspect accessible bolts, nuts, screws, terminals and fittings for security.
2. Check belt tension, adjust if necessary (refer to Adjustment Section).
3. Energize electrical circuit to tumbler circuit breaker and turn on tumbler disconnect switch.
4. Turn on gas supply at manual gas shut off valve in gas supply line (gas models only). Handle of gas shut off valve should be parallel with gas supply line when in "ON" position.
5. Press and hold in Push-to-Start Button for approximately three (3) seconds. Release button and open cylinder door. Cylinder should stop rotating within seven (7) seconds after door is opened 3" (7.5 cm) plus or minus 1/4" (0.635 cm). If cylinder does not stop rotating, adjust cylinder door interlock (refer to Adjustment Section).
6. Load tumbler with clothes or clean rags.
7. Start tumbler and check burner flame, adjust gas inlet shutter if necessary (refer to Adjustment Section).
8. Check air flow switch operation by opening lint panel. Heating system should shut off when lint panel is opened approximately 1-1/2" (3.81 cm). Adjust if necessary (refer to Adjustment Section).
9. Turn off tumbler.
10. Check air flow switch operation by opening lint panel. Heating systems should shut off when lint panel is opened approximately 6" (15.24 cm) with a full load.

FINAL OPERATING CHECKS

Manual Dual Timer Tumbler

1. Set temperature selector to HIGH and set drying and cool down selectors to their maximum settings.
2. Press and hold in Push-to-Start Button for approximately three (3) seconds. Motor will start, heat system will turn on, drying indicator will light and drying selector will rotate counterclockwise.
3. When drying selector reaches zero (0) heat system will shut off, drying indicator will turn off, cooling indicator will light and cooling selector will rotate counterclockwise.
4. When cooling selector reaches zero (0) motor will stop and cooling indicator will turn off indicating drying cycle is finished.

Coin Operated Tumbler

1. Set temperature selector to HIGH.
2. Insert required amount of coins.
3. Press and hold in Push-to-Start Button for approximately three (3) seconds. Motor will start and heat system will turn on.
4. Near end of cycle a preset 2 1/2 minute cool down cycle will start.
5. When metered time expires, motor will stop indicating drying cycle is finished.

Electronic Control Tumbler

Tumbler comes equipped with Electronic Control. Electronic Control gives owner a variety of programming options. To learn how to use Electronic Control, consult supplemental manual.

SECTION III

Adjustments

MAIN GAS BURNER AIR SHUTTER (All Gas Models)

NOTICE: Both air inlet shutters on burner must be adjusted so sufficient air is metered into system for proper combustion and maximum efficiency. Before adjusting inlet shutters be sure that all lint is removed from lint compartment and lint screen.

Air shutter adjustments will vary from location to location and will depend on vent system, number of units installed, make-up air and line gas pressure. Opening shutter increases amount of primary air supplied to burner while closing shutter decreases primary air supply. Adjust air shutter as follows:

1. Unlock and open access door.
2. Start tumbler and check flame pattern. Correct air and gas mixture is indicated if flame pattern is primarily blue, with small yellow tips, and bends to right of heater section. (See *Figure 29*.) Too little air is indicated if flame is yellow, lazy and smokey.
3. To adjust air shutter, loosen air inlet shutter adjusting screw, see *Figure 29*.
4. Open or close air shutter as necessary to obtain proper flame intensity.

5. After air shutter is adjusted for proper flame, tighten air shutter adjusting screw securely. Control panel may have to be removed temporarily to loosen air shutter screws to turn shutter.
6. If shutter is correctly adjusted, but flame pattern is straight up, (*Figure 29*), insufficient primary air is flowing through tumbler and airflow switch is improperly set. A flame pattern that flares to right and left (*Figure 29*) indicates no air is flowing through tumbler.

AIR FLOW SWITCH (Gas and Electric Models, see *Figure 30*)

Air flow switch is set at factory for proper operation. Steam models do not have an air flow switch. However, if there is a problem with airflow switch, it should be adjusted as follows:

NOTICE: Control panel must be in place and access door closed before attempting to adjust air flow switch.

IMPORTANT: Air flow switch disc must remain closed during operation. If it opens and closes during drying cycle, this indicates insufficient air flow through tumbler.

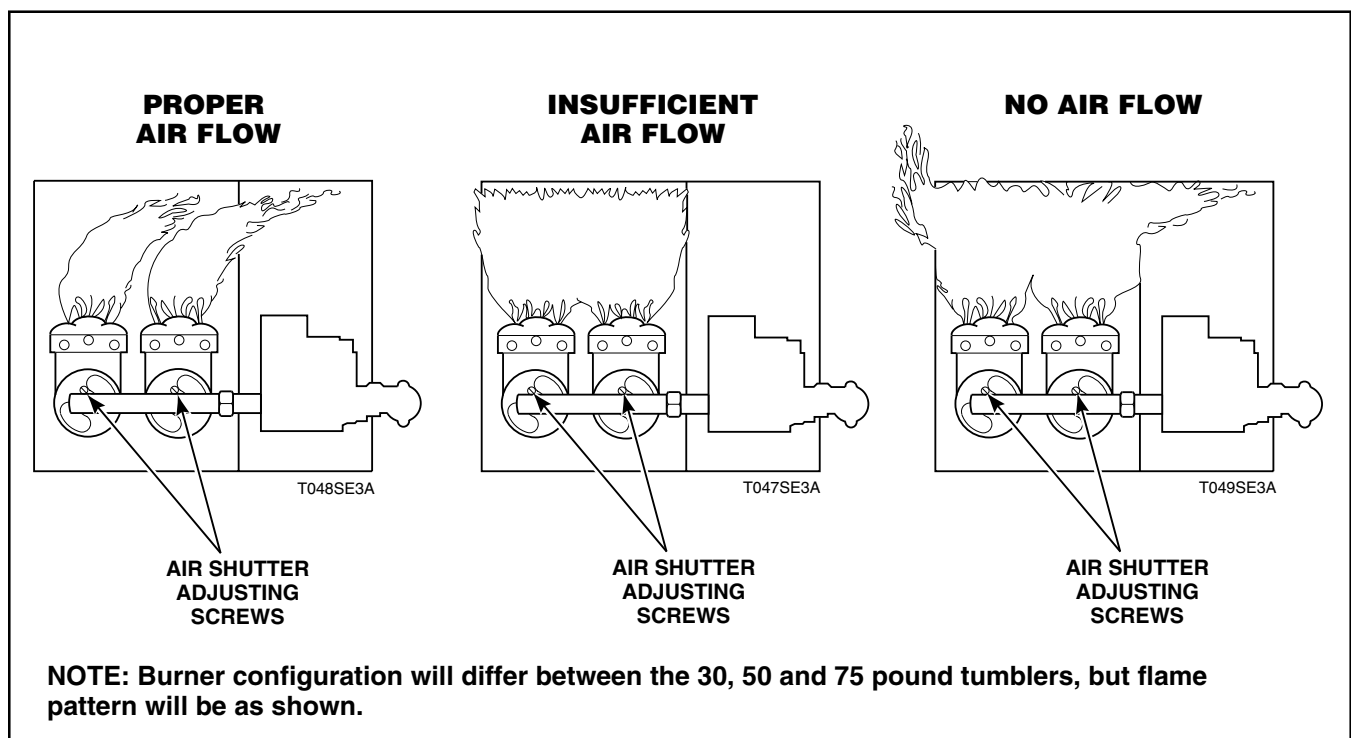

Figure 29

Electric Models: If switch remains open, or pops open and closed during cycle, heating system will shut off. Cylinder and fan will continue to operate even though air flow switch is malfunctioning.

Gas Models: If switch remains open, entire unit will shut down when Push-to-start button is released. Once tumbler starts and continues to run, a loss of air flow, air flow switch jams or a bouncing air flow switch will shut entire tumbler down.

⚠ WARNING

To reduce the risk of fire, air flow switch operation may be affected by a clogged lint screen, lack of make-up air, obstructions in the vertical recirculation stack or in the customer installed main or collector ducts. These conditions must be checked and necessary corrections made before adjusting air flow switch. Always adjust air flow at installation.

Air flow switch operation is controlled by counterweight position on shaft. Moving counterweight either increases or decreases air flow switch sensitivity.

Counterweight should be adjusted so air flow will force disc away from cabinet when lint panel is opened 6 inches (15.24 cm) with a full load. Adjust air flow switch as follows:

1. Load tumbler.

NOTE: This adjustment is much faster to make with one person opening lint panel in front and another adjusting the counterweight in rear of tumbler.

2. Start tumbler. Open lint panel 6 inches (15.24 cm). Airflow disc should move away from cabinet, opening switch contacts and shutting off heat system. This indicates proper operation and proper adjustment.
3. If switch is not opening as described in step "2", it should be adjusted so it is MORE sensitive. Depress spring clip and move counterweight toward disc. Retest by opening lint panel and continue moving counterweight toward disc until switch operates as described in step "2".
4. If switch opens BEFORE lint panel is opened proper distance, step "2", it should be adjusted so it is LESS sensitive. Depress spring clip and move counterweight away from disc. Retest by opening lint panel and continue moving counterweight away from disc until switch operates as described in step "2".

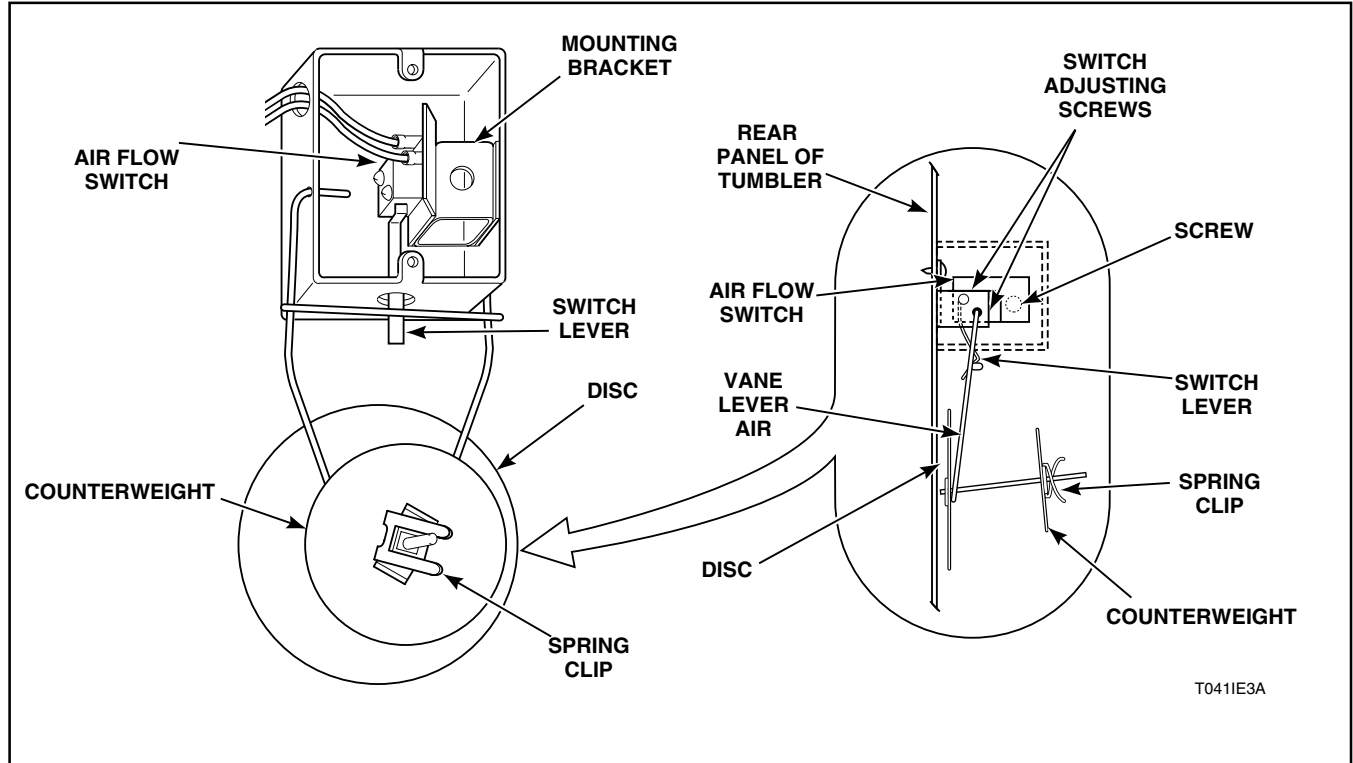

Figure 30

LOADING DOOR SWITCH

Loading door switch turns off tumbler any time loading door is opened. To adjust loading door switch, follow these steps:

1. Start tumbler following operating instructions which accompanied it.
2. Slowly open loading door. Cylinder and heating system should stop when door is open 3" (7.5 cm) plus or minus 1/4" (0.635 cm).
3. Slowly close loading door. Loading door switch should close with an audible "click" when loading door is closed 3" (7.5 cm) plus or minus 1/4" (0.635 cm).
4. If loading door switch does not close when loading door is closed 3" (7.5 cm) plus or minus 1/4" (0.635 cm):
 - a. Close loading door completely.
 - b. Loosen lower screw on switch coupler and rotate switch coupler COUNTERCLOCKWISE until it stops.
 - c. Tighten lower screw on switch coupler.
 - d. Return to step 1 to verify loading door switch operation.

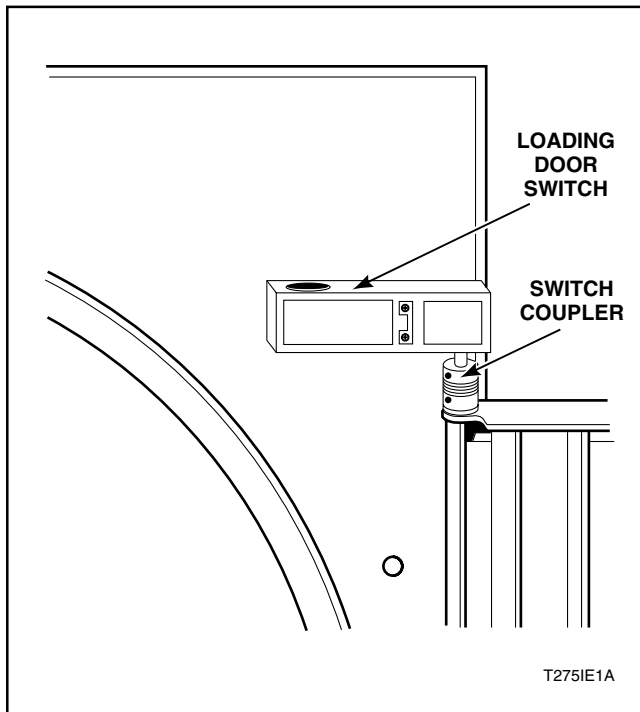

Figure 31

CYLINDER DOOR STRIKE

The door strike must be adjusted to have sufficient tension to hold loading door closed against force of load tumbling against it. Proper adjustment is when 8 to 15 pounds (35.6 N - 66.7 N) pull is required to open door.

To adjust, open door, loosen jamnut and turn door strike screw in or out as required. Retighten jamnut.

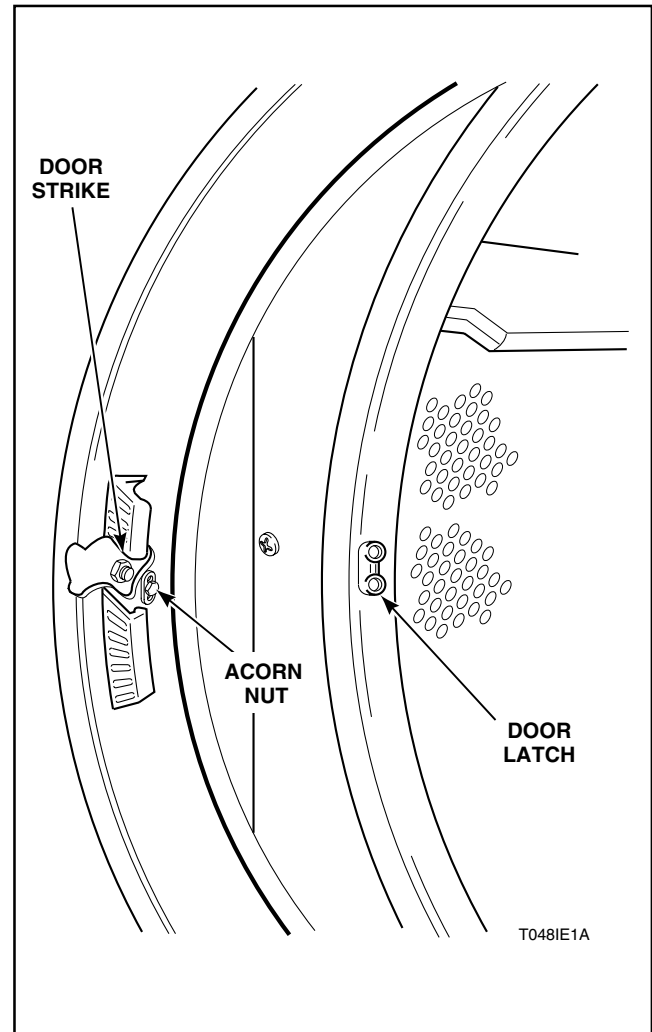

Figure 32

DRIVE V-BELT

⚠ WARNING

To reduce the risk of serious injury or death, disconnect power to the tumbler before performing this operation.

Proper tension is when belt can be depressed approximately ½ inch (1.27 cm) by applying light thumb pressure at a point midway between the sheave and motor pulley.

1. Remove guard from rear of tumbler.

⚠ WARNING

To reduce the risk of serious injury or death, guard MUST be installed on rear of tumbler after belt adjustment is made.

2. To adjust belt tension, loosen adjusting bolt holding idler housing assembly to housing support.
3. To tighten V-belt:
 - a. Loosen lower nut on adjusting bolt.
 - b. Turn bolt up until belt has proper tension.
 - c. Tighten upper and lower nut or adjusting bolt.
4. To loosen V-belt:
 - a. Loosen top nut on adjusting bolt.
 - b. Turn bolt down until belt has proper tension.
 - c. Tighten upper and lower nut or adjusting bolt.
5. Replace guard on rear of tumbler.
6. Upper belt requires no adjustment since it is self-adjusting.

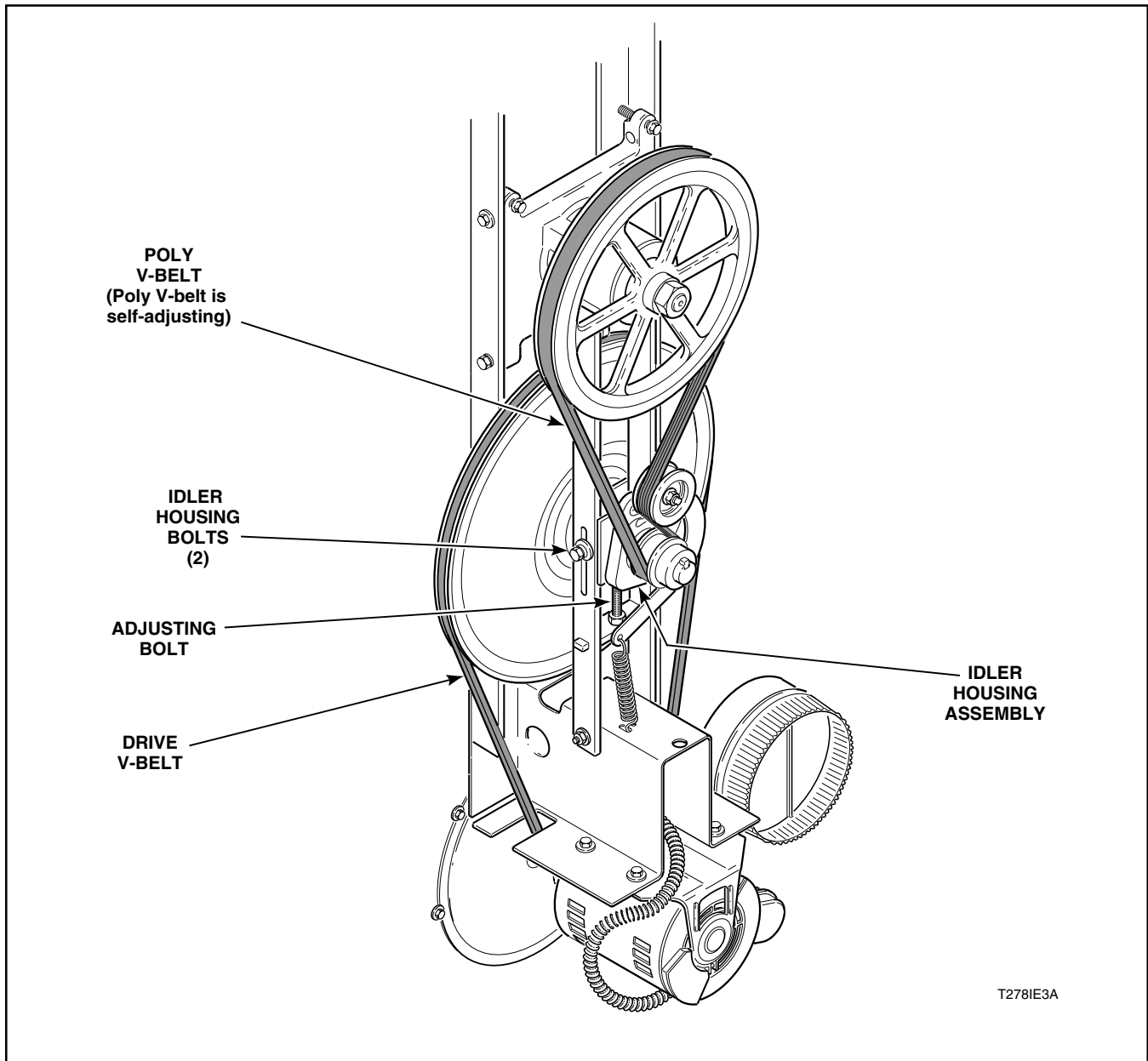

Figure 33

SECTION IV

Preventive Maintenance Instructions

DAILY

1. Make certain drying cycle has ended.
2. Open loading door.
3. Unlock and remove lint panel.
4. Remove accumulated lint in lint compartment. Lint left in lint compartment will be drawn back onto lint screen and restrict air circulation.
5. Clean lint from lint screen. If lint screen is torn replace immediately. A torn lint screen allows lint to flow into ductwork system restricting air circulation.
6. Ensure lint screen covers entire opening in lint screen hood. Gaps between lint screen and lint screen hood allows lint to flow into ductwork system restricting air circulation.
7. Wipe any accumulated lint off thermostat sensing probe. Lint buildup on sensing probe will cause overheating of tumbler.
8. Replace and securely lock lint panel.

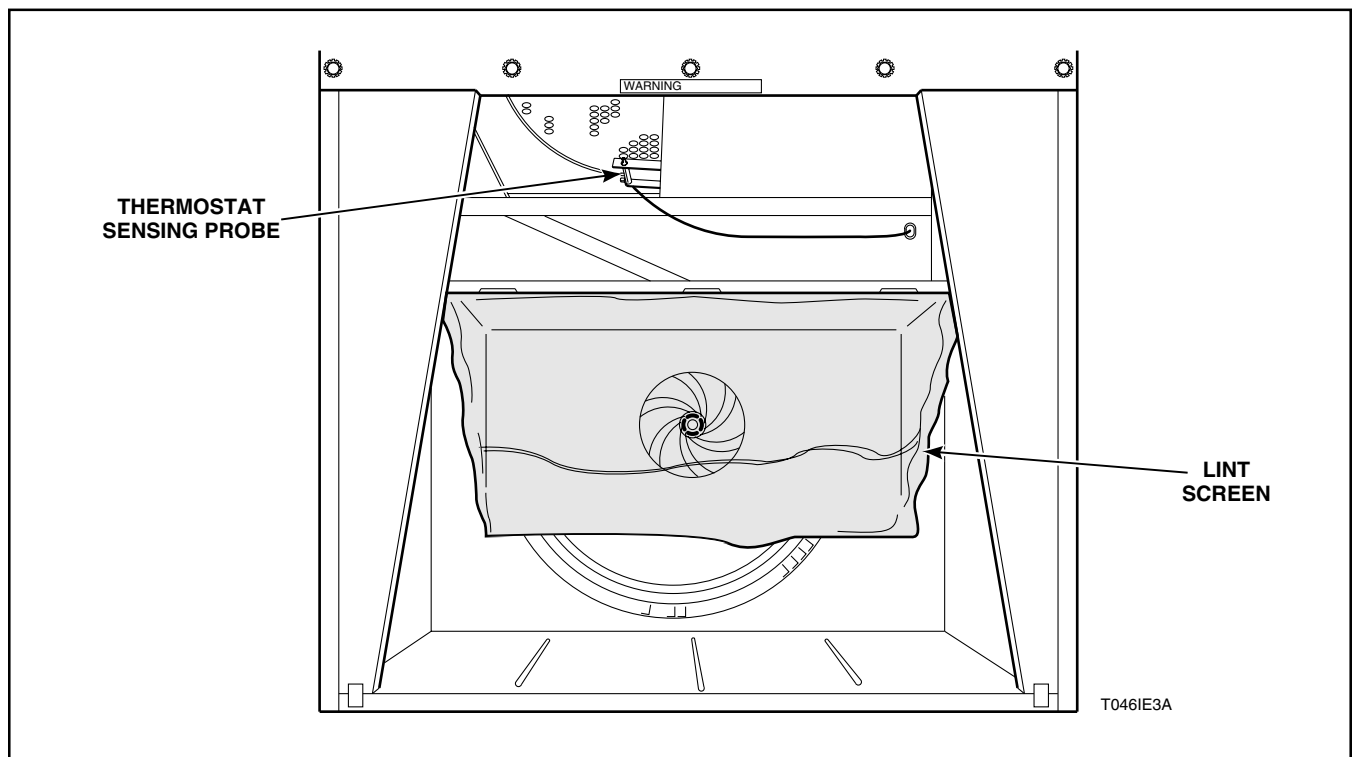

Figure 34

MONTHLY

1. Perform daily cleaning of accumulated lint.
2. Deactivate electrical circuit by turning off electrical disconnect switch on rear of tumbler.
4. Remove exhaust duct from rear of tumbler and clean out all accumulated lint.
5. Reinstall exhaust duct.
6. Remove bottom cover from vertical exhaust duct and clean out all accumulated lint.
7. Reinstall vertical exhaust duct cover.
8. Inspect entire duct work assembly and clean out all accumulated lint.
9. Energize electrical circuit to tumbler by turning on electrical disconnect switch on rear of tumbler.

Quarterly

1. Deactivate electrical circuit by turning off disconnect switch on rear of tumbler.
2. Perform daily cleaning of accumulated lint.
3. Perform monthly inspection and cleaning of accumulated lint.
4. Clean accumulated lint and other debris from front and back motor air vents.
5. Shut off gas supply at manual gas shut off valve in gas supply line (gas models only). Handle of gas shut off valve should be at 90° angle to gas supply line when in "OFF" position.
6. Remove screws holding rear drive guard to back of tumbler.
7. Inspect belts for wear and proper tension (refer to Adjustments section).
8. Reinstall rear drive guard to back of tumbler.
9. Energize electrical circuit to tumbler by turning on electrical disconnect switch on rear of tumbler.
10. Turn on gas supply at manual gas shut off valve in gas supply line (gas models only). Handle of gas shut off valve should be parallel with gas supply line when in "ON" position.

Biannually

1. Deactivate electrical circuit by turning off disconnect switch on rear of tumbler.
2. Perform daily cleaning of accumulated lint.
3. Perform monthly inspection and cleaning of accumulated lint.
4. Perform quarterly inspection and cleaning of accumulated lint.
5. Remove or open all panels and check accessible bolts, nuts, screws, terminals and fittings for tightness.
6. Shut off gas supply at manual gas shut off valve in gas supply line (gas models only). Handle of gas shut off valve should be at 90° angle to gas supply line when in "OFF" position.
7. Unlock and open service panel and inspect gas connections for evidence of leakage or loose connections.
8. Close and securely lock service panel.
9. Open electrical junction box cover and inspect all electrical and grounding connections for security. Tighten any loose electrical connections.
10. Close electrical junction box cover and energize electrical circuit to tumbler by turning on electrical disconnect switch.
11. Turn on gas supply at manual gas shut off valve in gas supply line (gas models only). Handle of gas shut off valve should be parallel with gas supply line when in "ON" position.

NOTE: Spraying a mild solution of soap and water on joints will cause bubbles to appear on any leaking connections.

QUARTERLY MAINTENANCE	(DATES)							
Clean air vents on drive motor.								
Check and clean steam coils. (Steam Models Only)								
Clean exhaust ducts.								
Check flow of combustion air.								
Check flow of ventilation air.								
Check belt tension.								

BIANNUAL MAINTENANCE	(DATES)							
Check for loose nuts.								
Check for loose bolts.								
Check for loose screws.								
Check for loose gas connections.								
Check for loose electrical connections.								
Check for loose steam connections. (Steam Models Only.)								

SECTION V

Decommissioning Instructions

1. Turn off electrical supply external to machine.
2. Turn off electrical disconnect on machine.
3. Turn off gas supply external to machine.
4. Turn off manual gas shut-off valve on machine.
5. Turn off steam supply external to machine.
6. Remove all electric, gas and steam connections.

Free Manuals Download Website

<http://myh66.com>

<http://usermanuals.us>

<http://www.somanuals.com>

<http://www.4manuals.cc>

<http://www.manual-lib.com>

<http://www.404manual.com>

<http://www.luxmanual.com>

<http://aubethermostatmanual.com>

Golf course search by state

<http://golfingnear.com>

Email search by domain

<http://emailbydomain.com>

Auto manuals search

<http://auto.somanuals.com>

TV manuals search

<http://tv.somanuals.com>