



DS06

HYDRAULIC DIAMOND SAW



⚠ WARNING

SERIOUS INJURY OR DEATH
COULD RESULT FROM IM-
PROPER REPAIR OR SERVICE
OF THIS TOOL.

REPAIRS AND/OR SERVICE
TO THIS TOOL MUST ONLY
BE DONE BY AN AUTHORIZED
AND CERTIFIED DEALER.

⚠ WARNING

To avoid serious injury or death

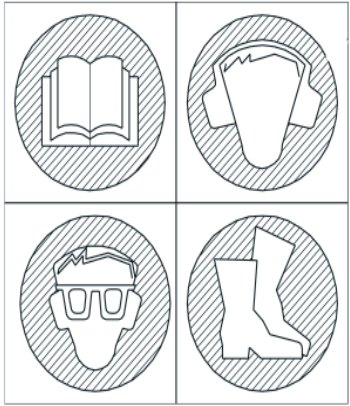

Copyright © 2005, The Stanley Works
OPS/MAINT USA
34567 8/2005 Ver 3

SAFETY, OPERATION AND MAINTENANCE SERVICE MANUAL

Stanley Hydraulic Tools
3810 SE Naef Road
Milwaukie OR 97267-5698
503-659-5660
FAX 503-652-1780

www.stanley-hydraulic-tools.com

TABLE OF CONTENTS

CERTIFICATE OF CONFORMITY	4
SAFETY SYMBOLS	5
SAFETY PRECAUTIONS	6
TOOL STICKERS & TAGS	8
HYDRAULIC HOSE REQUIREMENTS	9
HTMA REQUIREMENTS	10
OPERATION	11
PREOPERATION PROCEDURES	11
CHECK THE POWER SOURCE	11
CHECK TOOL	11
CONNECT HYDRAULIC HOSES	11
CONNECTING TO A WATER SUPPLY	11
CHECK CHAIN AND BAR ADJUSTMENT	11
CHECK CHAIN SEGMENT WEAR	12
OPERATING PROCEDURES	12
PLAN THE CUT	12
TYPES OF CUTS	13
COLD WEATHER OPERATION	13
USING THE WALL WALKER™	13
MAINTENANCE & ADJUSTMENTS	14
GENERAL MAINTENANCE TIPS	14
SAW BAR RAIL	14
ROTATING THE SAW BAR	14
CHAIN TENSION ADJUSTMENT	14
SERVICING THE CHAIN	15
MAINTENANCE & ADJUSTMENTS	15
MAINTENANCE & ADJUSTMENTS	16
REPLACING THE CHAIN BREAKER PUNCH	16
SPINNING RIVETS	16
NOSE SPROCKET DISASSEMBLY AND ASSEMBLY	17
MAINTENANCE & ADJUSTMENTS	17
TOOL EQUIPMENT & CARE	19
TROUBLESHOOTING	20
SPECIFICATIONS	22
ACCESSORIES	22
SERVICE	23
MOTOR INSPECTION AND CLEANING	24
BAR & CHAIN AND CHAIN GUARD ASSEMBLY	26
DS06 PARTS ILLUSTRATION	27
DS06 PARTS LIST	28
DS06 PARTS ILLUSTRATION	29
DS06 PARTS LIST	30
DIAMOND CHAIN APPLICATIONS	31
WARRANTY	32

SERVICING THE STANLEY CONCRETE CHAINSAW: This manual contains safety, operation, and routine maintenance instructions. Servicing of hydraulic tools, other than routine maintenance, must be performed by an authorized and certified dealer. Please read the following warning.

⚠ WARNING

SERIOUS INJURY OR DEATH COULD RESULT FROM THE IMPROPER REPAIR OR SERVICE OF THIS TOOL.

REPAIRS AND / OR SERVICE TO THIS TOOL MUST ONLY BE DONE BY AN AUTHORIZED AND CERTIFIED DEALER.

For the nearest authorized and certified dealer, call Stanley Hydraulic Tools at the number listed on the back of this manual and ask for a Customer Service Representative.

**CERTIFICATE OF CONFORMITY
ÜBEREINSTIMMUNGS-ZERTIFIKAT
CERTIFICAT DE CONFORMITE CEE
CERTIFICADO DE CONFORMIDAD
CERTIFICATO DI CONFORMITA**



Hydraulic Tools

I, the undersigned:
Ich, der Unterzeichnende:
Je soussigné:
El abajo firmante:
Io sottoscritto:

Schultz, Theodore J.

Surname and First names/Familiennname und Vornamen/Nom et prénom/Nombre y apellido/Cognome e nome

**hereby certify that the construction plant or equipment specified hereunder:
bestätige hiermit, daß das im folgenden genannten Werk oder Gerät:
certifies par ceci que l' usine ou l' équipement de construction indiqué cidessous:
por el presente certifico que la fabrica o el equipo especificado a continuacion:
certifico che l'impianto o l'attrezzatura sotto specificata:**

- Category: Concrete Cutting Chainsaw
Kategorie:
Catégorie:
Categoria:
Categoria:
- Make/Ausführung/Marque/Marca/Marca **Stanley**
- Type/Typ/Type/Tipo/Tipo: DS06200001, DS06300001
- Serial number of equipment:
Seriennummer des Geräts:
Numéro de série de l'équipement:
Numero de serie del equipo:
Matricola dell'attrezzatura:
All
- Year of manufacture/Baujahr/année de fabrication/Año de fabricacion/Anno di fabbricazione **1998**

**Has been manufactured in conformity with - EEC Type examination as shown.
Wurde hergestellt in Übereinstimmung mit - EEC Typ-Prüfung nach.
Est fabriqué conformément - au(x) type(s) examiné(s) comme indiqué dans le tableau ci-après.
Ha sido fabricado de acuerdo con - tipo examen EEC como dice.
E' stata costruita in conformità con - le norme CEE come illustrato.**

Examen CEE de type				
Directive Richtlinie Directives particulières Directriz Direttiva	No. Nr Numéro No n.	Date Datum Date Fecha Data	Approved body Prüfung durch Organisme agréé Aprobado Collaudato	Date of expiry Ablaufdatum Date d'expiration Fecha de caducidad Data di scadenza
Machinery Directive	98/37/EC 89/392/CEE	1998	Self	NA
EN	292	1991	Self	NA
ISO	8662-1	1988	Self	NA
ISO	3744	1994	Self	NA
ISO	10726	1992	Self	NA

- Special Provisions: None
Spezielle Bestimmungen:
Dispositions particulières:
Provisiones especiales:
Disposizioni speciali:

Done at/Ort/Fait à/Dado en/Fatto a Stanley Hydraulic Tools, Milwaukie, Oregon USA Date/Datum/le/Fecha/Data **3/98**

Signature/Unterschrift/Signature/Firma/Firma _____  _____

Position/Position/Fonction/Puesto/Posizione Engineering Manager

P/N 62310 rev 03 3/05

SAFETY SYMBOLS

Safety symbols and signal words, as shown below, are used to emphasize all operator, maintenance and repair actions which, if not strictly followed, could result in a life-threatening situation, bodily injury or damage to equipment.



This is the safety alert symbol. It is used to alert you to potential personal injury hazards. Obey all safety messages that follow this symbol to avoid possible injury or death.



This safety alert and signal word indicate an imminently hazardous situation which, if not avoided, will result in death or serious injury.



This safety alert and signal word indicate a potentially hazardous situation which, if not avoided, could result in death or serious injury.



This safety alert and signal word indicate a potentially hazardous situation which, if not avoided, may result in minor or moderate injury.



This signal word indicates a potentially hazardous situation which, if not avoided, may result in property damage.



This signal word indicates a situation which, if not avoided, will result in damage to the equipment.



This signal word indicates a situation which, if not avoided, may result in damage to the equipment.

Always observe safety symbols. They are included for your safety and for the protection of the tool.

LOCAL SAFETY REGULATIONS

Enter any local safety regulations here. Keep these instructions in an area accessible to the operator and maintenance personnel.

SAFETY PRECAUTIONS

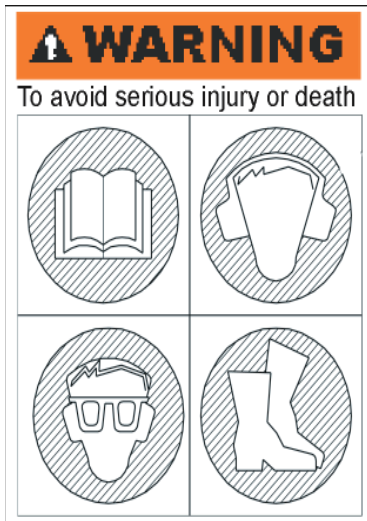

Tool operators and maintenance personnel must always comply with the safety precautions given in this manual and on the stickers and tags attached to the tool and hose.

These safety precautions are given for your safety. Review them carefully before operating the tool and before performing general maintenance or repairs.

Supervising personnel should develop additional precautions relating to the specific work area and local safety regulations. If so, place the added precautions in the space provided on page 5.

The DS06 Diamond Chain Saw will provide safe and dependable service if operated in accordance with the instructions given in this manual. Read and understand this manual and any stickers and tags attached to the tool and hoses before operation. Failure to do so could result in personal injury or equipment damage.

- Establish a training program for all operators to ensure safe operation.
- The operator must be familiar with all prohibited work areas such as excessive slopes and dangerous terrain conditions.
- Do not operate the chain saw unless thoroughly trained or under the supervision of an instructor.
- Always wear safety equipment such as goggles, ear, head protection, leg protection, gloves, snug fitting clothing and safety shoes at all times when operating the chain saw.
- Do not overreach. Maintain proper footing and balance at all times.
- Do not inspect or clean the chain saw while the hydraulic power source is connected. Accidental engagement of the chain saw can cause serious injury.
- Always connect hoses to the chain saw hose couplers before energizing the hydraulic power source. Make sure all hose connections are tight.
- Do not operate the chain saw at fluid temperatures above 140°F/60°C. Operation at higher temperatures can cause higher than normal temperatures at the chain saw which can result in operator discomfort.
- Do not rely exclusively upon the safety devices built into the chain saw. As a chain saw user, several steps must be taken to keep your cutting jobs free from accident or injury:
 1. With a basic understanding of kickbacks, you can reduce or eliminate the element of surprise. Sudden surprise contributes to accidents.
 2. Keep a good firm grip on the chain saw with both hands, the right hand on the rear handle and the left hand on the front handle when operating the chain saw. Use a firm grip with thumbs and fingers encircling the chain saw handles. A firm grip helps reduce kickbacks and maintains control of the chain saw. Do not let go.
 3. Make sure the area in which you are cutting is free of obstructions.
 4. Cut at rated operating speeds (gpm).
 5. Do not overreach or cut above shoulder height.
 6. Only use replacement bars and chains specified by Stanley or the equivalent.
- Make sure the chain guard is in place before operating the chain saw.

SAFETY PRECAUTIONS

- Remove or control the water slurry to prevent yourself or others from slipping while cutting.
- Provide adequate ventilation in closed areas when operating a gas or diesel hydraulic power source.
- Always be well rested and mentally alert before operating the chain saw.
- Do not allow bystanders near the chain saw when starting or cutting.
- Do not start cutting until you have a clear work area and secure footing.
- Keep all parts of the body away from the chain saw during operation.
- Carry the chain saw with the tool deenergized and the bar and chain to the rear of your body.
- Do not operate a chain saw that is damaged, improperly adjusted, or not completely and securely assembled. Make sure the chain stops moving when the control trigger is released.
- Keep the handle dry, clean and free of hydraulic fluid.
- Do not use the chain saw near energized transmission lines.
- Turn off the power source or move the hydraulic control valve to neutral before setting the chain saw down.
- Use a guide bar scabbard when transporting the chain saw.
- Know the location of buried or covered electrical services before starting work.
- To avoid personal injury or equipment damage, all chain saw repair, maintenance and service must only be performed by authorized and properly trained personnel.
- Make sure the chain breaker and rivet spinner are securely mounted on flat, clean work surfaces. Check the mounting screws/bolts often.
- Check all chain breaker and rivet spinner components regularly for wear and general condition.

TOOL STICKERS & TAGS

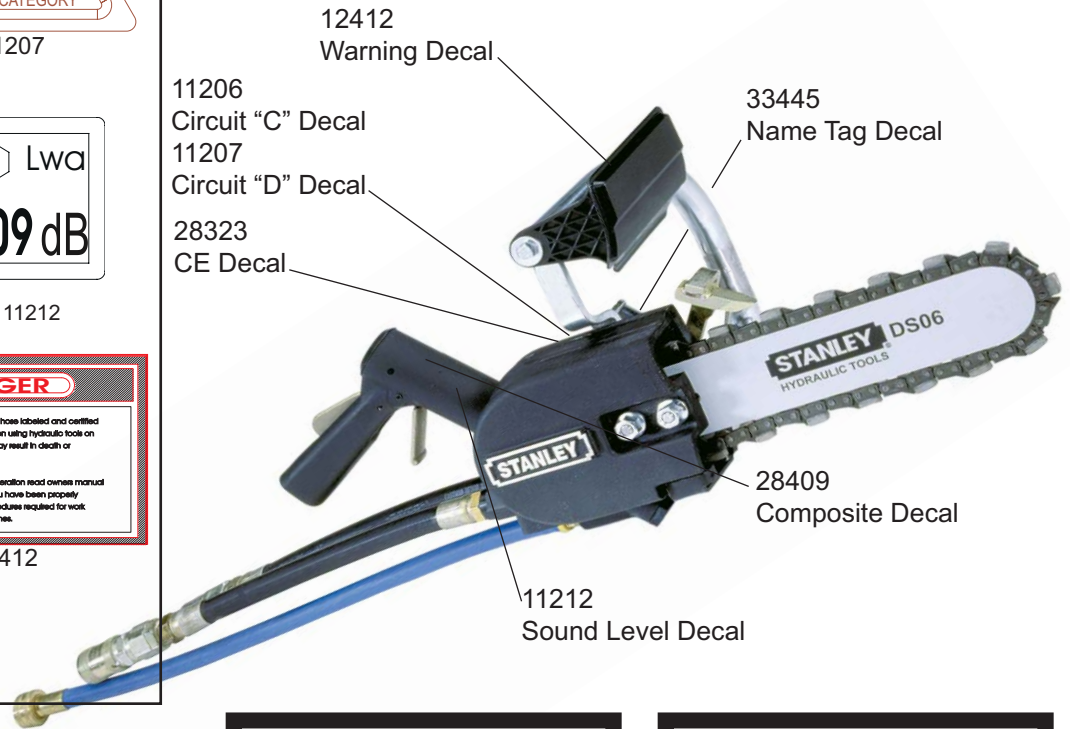
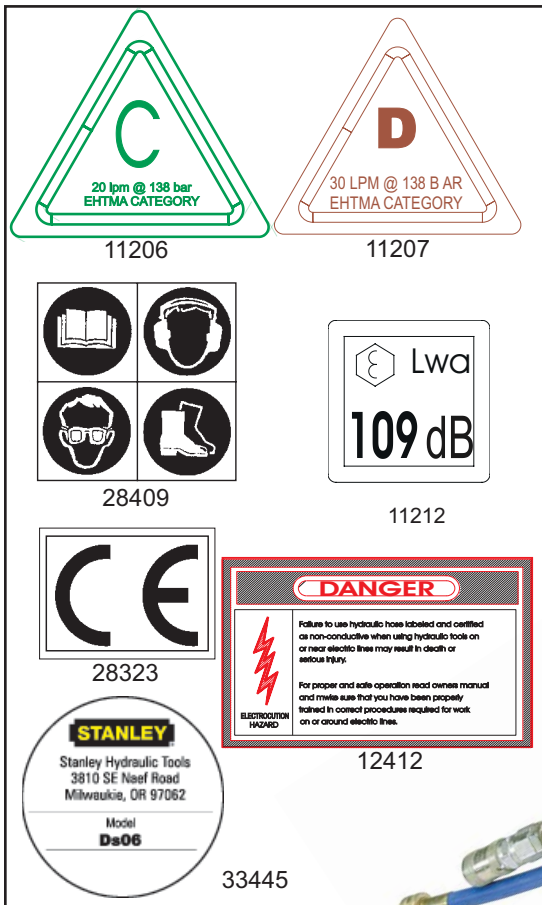

The safety tag (p/n 15875) at right is attached to the tool when shipped from the factory. Read and understand the safety instructions listed on this tag before removal. We suggest you retain this tag and attach it to the tool when not in use.

DANGER

1. FAILURE TO USE HYDRAULIC HOSE LABELED AND CERTIFIED AS NON-CONDUCTIVE WHEN USING HYDRAULIC TOOLS ON OR NEAR ELECTRICAL LINES MAY RESULT IN DEATH OR SERIOUS INJURY.

BEFORE USING HOSE LABELED AND CERTIFIED AS NON-CONDUCTIVE ON OR NEAR ELECTRIC LINES BE SURE THE HOSE IS MAINTAINED AS NON-CONDUCTIVE. THE HOSE SHOULD BE REGULARLY TESTED FOR ELECTRIC CURRENT LEAKAGE IN ACCORDANCE WITH YOUR SAFETY DEPARTMENT INSTRUCTIONS.
2. A HYDRAULIC LEAK OR BURST MAY CAUSE OIL INJECTION INTO THE BODY OR CAUSE OTHER SEVERE PERSONAL INJURY.
 - A. **DO NOT EXCEED SPECIFIED FLOW AND PRESSURE FOR THIS TOOL.** EXCESS FLOW OR PRESSURE MAY CAUSE A LEAK OR BURST.
 - B. **DO NOT EXCEED RATED WORKING PRESSURE OF HYDRAULIC HOSE USED WITH THIS TOOL.** EXCESS PRESSURE MAY CAUSE A LEAK OR BURST.
 - C. CHECK TOOL HOSE COUPLERS AND CONNECTORS DAILY FOR LEAKS. **DO NOT FEEL FOR LEAKS** WITH YOUR

IMPORTANT

READ OPERATION MANUAL AND SAFETY INSTRUCTIONS FOR THIS TOOL BEFORE USING IT.

USE ONLY PARTS AND REPAIR PROCEDURES APPROVED BY STANLEY AND DESCRIBED IN THE OPERATION MANUAL.

TAG TO BE REMOVED ONLY BY TOOL OPERATOR.

SEE OTHER SIDE

DANGER

- D. DO NOT LIFT OR CARRY TOOL BY THE HOSES. DO NOT ABUSE HOSE. DO NOT USE KINKED, TORN OR DAMAGED HOSE.
3. MAKE SURE HYDRAULIC HOSES ARE PROPERLY CONNECTED TO THE TOOL BEFORE PRESSURING SYSTEM. SYSTEM PRESSURE HOSE MUST ALWAYS BE CONNECTED TO TOOL "IN" PORT. SYSTEM RETURN HOSE MUST ALWAYS BE CONNECTED TO TOOL "OUT" PORT. REVERSING CONNECTIONS MAY CAUSE REVERSE TOOL OPERATION WHICH CAN RESULT IN SEVERE PERSONAL INJURY.
4. DO NOT CONNECT OPEN-CENTER TOOLS TO CLOSED-CENTER HYDRAULIC SYSTEMS. THIS MAY RESULT IN LOSS OF OTHER HYDRAULIC FUNCTIONS POWERED BY THE SAME SYSTEM AND/OR SEVERE PERSONAL INJURY.
5. BYSTANDERS MAY BE INJURED IN YOUR WORK AREA. KEEP BYSTANDERS CLEAR OF YOUR WORK AREA.
6. WEAR HEARING, EYE, FOOT, HAND AND HEAD PROTECTION.
7. TO AVOID PERSONAL INJURY OR EQUIPMENT DAMAGE, ALL TOOL REPAIR MAINTENANCE AND SERVICE MUST ONLY BE PERFORMED BY AUTHORIZED AND PROPERLY TRAINED PERSONNEL.

IMPORTANT

READ OPERATION MANUAL AND SAFETY INSTRUCTIONS FOR THIS TOOL BEFORE USING IT.

USE ONLY PARTS AND REPAIR PROCEDURES APPROVED BY STANLEY AND DESCRIBED IN THE OPERATION MANUAL.

TAG TO BE REMOVED ONLY BY TOOL OPERATOR.

SEE OTHER SIDE

SAFETY TAG P/N 15875 (shown smaller than actual size)

HYDRAULIC HOSE REQUIREMENTS

HOSE TYPES

Hydraulic hose types authorized for use with Stanley Hydraulic Tools are as follows:

- 1 Certified non-conductive
- 2 Wire-braided (conductive)
- 3 Fabric-braided (not certified or labeled non-conductive)

Hose 1 listed above is the only hose authorized for use near electrical conductors.

Hoses 2 and 3 listed above are **conductive** and **must never** be used near electrical conductors.

HOSE SAFETY TAGS

To help ensure your safety, the following DANGER tags are attached to all hose purchased from Stanley Hydraulic Tools. **DO NOT REMOVE THESE TAGS.**

If the information on a tag is illegible because of wear or damage, replace the tag immediately. A new tag may be obtained from your Stanley Distributor.

THE TAG SHOWN BELOW IS ATTACHED TO “CERTIFIED NON-CONDUCTIVE” HOSE

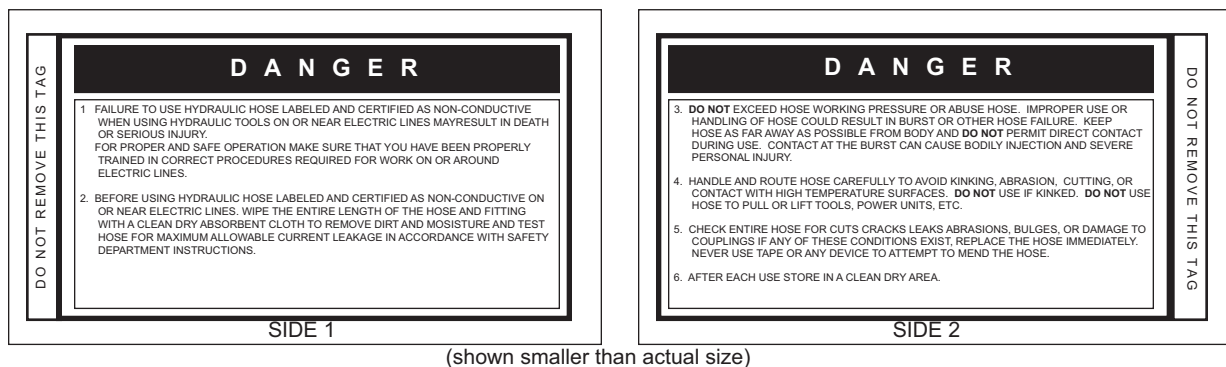

THE TAG SHOWN BELOW IS ATTACHED TO “CONDUCTIVE” HOSE.

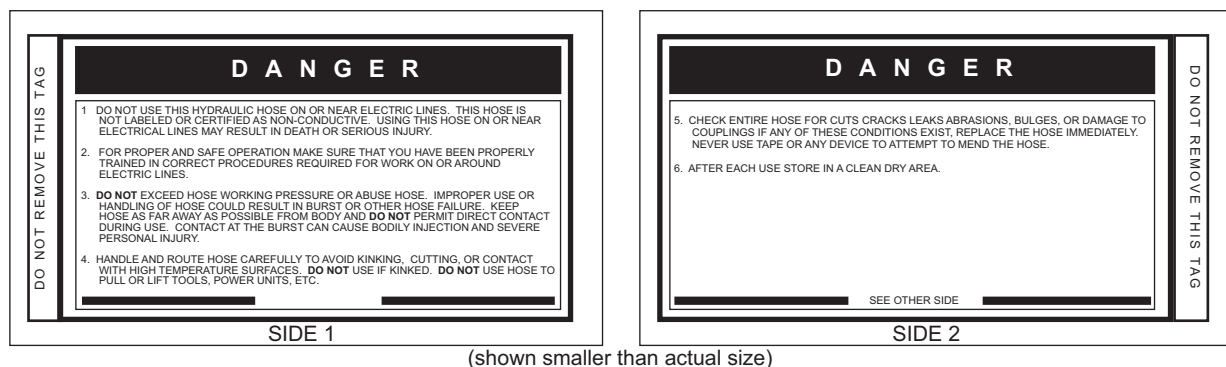

HOSE PRESSURE RATING

The rated working pressure of the hydraulic hose **must be equal to or higher than** the relief valve setting on the hydraulic system.

HTMA REQUIREMENTS

TOOL CATEGORY



HYDRAULIC SYSTEM REQUIREMENTS

TYPE 1

TYPEII

TYPEIII

TYPE RR

FLOW RATE	4-6 gpm (15-23 lpm)	7-9 gpm (26-34 lpm)	11-13 gpm (42-49 lpm)	9-10.5 gpm (34-40 lpm)
TOOL OPERATING PRESSURE (at the power supply outlet)	2000 psi (138 bar)	2000 psi (138 bar)	2000 psi (138 bar)	2000 psi (138 bar)
SYSTEM RELIEF VALVE SETTING (at the power supply outlet)	2100-2250 psi (145-155 bar)	2100-2250 psi (145-155 bar)	2100-2250 psi (145-155 bar)	2200-2300 psi (152-159 bar)
MAXIMUM BACK PRESSURE (at tool end of the return hose)	250 psi (17 bar)	250 psi (17 bar)	250 psi (17 bar)	250 psi (17 bar)
Measured at a max. fluid viscosity of: (at min. operating temperature)	400 ssu* (82 centistokes)	400 ssu* (82 centistokes)	400 ssu* (82 centistokes)	400 ssu* (82 centistokes)
TEMPERATURE Sufficient heat rejection capacity to limit max. fluid temperature to: (at max. expected ambient temperature)	140° F (60° C)	140° F (60° C)	140° F (60° C)	140° F (60° C)
Min. cooling capacity at a temperature difference of between ambient and fluid temps	3 hp (2.24 kW) 40° F (22° C)	5 hp (3.73 kW) 40° F (22° C)	7 hp (4.47 kW) 40° F (22° C)	6 hp (5.22 kW) 40° F (22° C)
NOTE: Do not operate the tool at oil temperatures above 140° F (60° C). Operation at higher temperatures can cause operator discomfort at the tool.				
FILTER Min. full-flow filtration Sized for flow of at least: (For cold temp. startup and max. dirt-holding capacity)	25 microns 30 gpm (114 lpm)	25 microns 30 gpm (114 lpm)	25 microns 30 gpm (114 lpm)	25 microns 30 gpm (114 lpm)
HYDRAULIC FLUID Petroleum based (premium grade, anti-wear, non-conductive) VISCOSITY (at min. and max. operating temps)	100-400 ssu*	100-400 ssu* (20-82 centistokes)	100-400 ssu*	100-400 ssu*
NOTE: When choosing hydraulic fluid, the expected oil temperature extremes that will be experienced in service determine the most suitable temperature viscosity characteristics. Hydraulic fluids with a viscosity index over 140 will meet the requirements over a wide range of operating temperatures.				

*SSU = Saybolt Seconds Universal

NOTE:

These are general hydraulic system requirements. See tool Specification page for tool specific requirements.

OPERATION

PREOPERATION PROCEDURES

CHECK THE POWER SOURCE

1. Using a calibrated flow meter and pressure gauge, make sure the hydraulic power source develops a flow of 7-9 gpm/26-34 lpm for the 8 gpm model and 4-6 gpm/15-23 lpm for the 5 gpm model at 2000 psi/140 bar.
2. Make certain that the power source is equipped with a relief valve set to open at 2100-2250 psi/145-155 bar.
3. Check that the hydraulic circuit matches the tool for open-center (OC) or closed-center (CC) operation. The DS06 is designed for open-center operation only.

CHECK TOOL

1. Make sure all tool accessories are correctly installed. Failure to install tool accessories properly can result in damage to the tool or personal injury.
2. There should be no signs of leaks.
3. The tool should be clean, with all fittings and fasteners tight.
4. Observe the arrow on the couplers to ensure that the hydraulic oil flow is in the proper direction. The female coupler is the inlet (pressure) coupler.
5. Check that the trigger operates smoothly and is free to travel between the "ON" and "OFF" positions.
6. Check that the chain is properly installed. The chain is designed to only operate in one direction. Make sure the chain is installed so the bumper guard precedes each diamond segment. See figure 1.

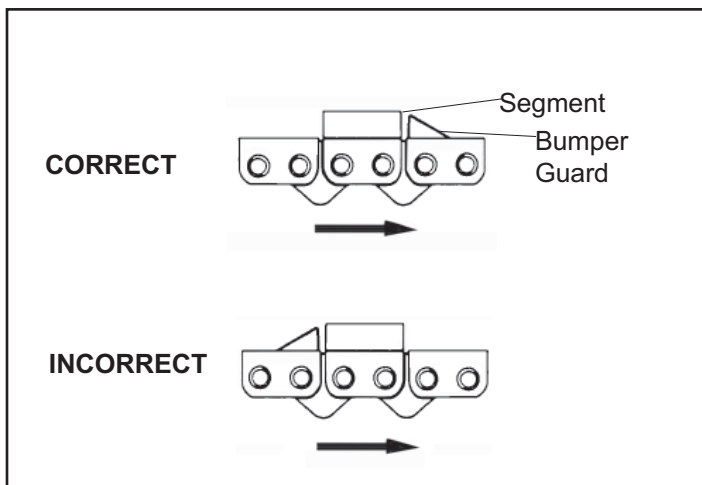

Figure 1. Chain Direction

CONNECT HYDRAULIC HOSES

1. Wipe all hose couplers with a clean lint-free cloth before making connections. If necessary, use a light-weight penetrating oil in a spray can to clean the hose couplers before each connection.
2. Connect the hoses from the hydraulic power source to the chain saw fittings or quick disconnects. It is a good practice to connect return hose first and disconnect them last to minimize or avoid trapped pressure within the chain saw.
3. Observe the arrow on the couplers to ensure that the flow is in the proper direction. The female coupler on the chain saw is the inlet (pressure) coupler.

NOTE:

If uncoupled hoses are left in the sun, pressure increase inside the hoses might make them difficult to connect. Whenever possible, connect the free ends of the hoses together.

CONNECTING TO A WATER SUPPLY

1. Using a standard garden hose, connect the DS06 to a city or auxiliary water supply. Make sure the flow is at least 4 gpm/15 lpm at 50 psi/3.5 bar.

IMPORTANT

Chain and bar damage will occur if the tool operates without the proper water supply and water pressure.

2. Make sure the water is running before starting the tool.
3. If a water pump is being used, refer to the manufacturers instructions for use of the pump. Make sure the pump produces a minimum water flow of 4 gpm/15 lpm at 50 psi/3.5 bar and the water pressure does not exceed 160 psi/11 bar.

CHECK CHAIN AND BAR ADJUSTMENT

Note:

Check the chain tension often during operation, especially during the first 1/2 hour when using a new chain. Adjust the chain accordingly when it becomes loose. Follow the procedures contained in the Maintenance and Adjustments section of this manual.

1. Make sure the chain does not exceed a clearance of 5/16 in./8 mm from the bar (see figure 2). Exceeding the maximum clearance increases the chance of the chain being dislodged from the bar groove.

OPERATION

2. Make sure the bar attaching nuts are fully tightened and the chain guard is in place.

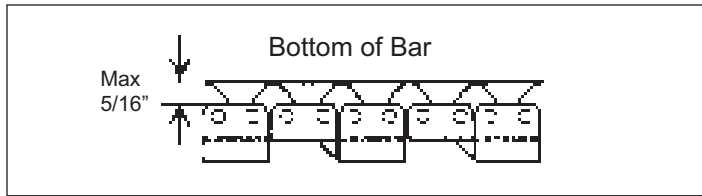

Figure 2. Maximum Chain Clearance

CHECK CHAIN SEGMENT WEAR

1. Using adjustable calipers, measure several chain segments as illustrated in Figure 3.

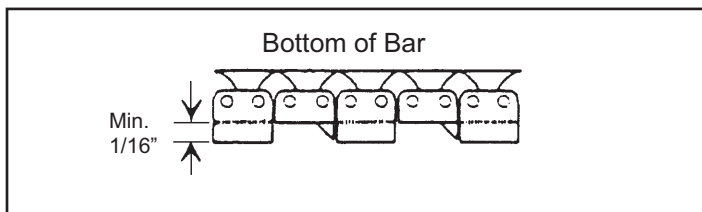

Figure 3. Chain Segment Wear

2. If the average measurement is less than 1/16-inch/1.6 mm, then the chain must be replaced. Refer to your Service Manual for chain replacement procedures.

OPERATING PROCEDURES

1. Observe all safety precautions.
2. Turn on the water supply. Water at the tool will be directed to the bar and chain when the trigger on the tool is squeezed "ON".
3. Operate the tool for two minutes away from the intended cut and then check the chain tension. New chain will normally stretch during its first usage. It is very important to keep the chain tension adjusted so that it does not exceed 5/16 in./8 mm clearance from the bottom of the bar. See Check Chain & Bar Adjustment in this manual.
4. If the chain requires adjustment, see Maintenance & Adjustments in this manual.

PLAN THE CUT

1. Plan your cuts to prevent injury to yourself and to keep from pinching the saw bar and chain as a result of falling pieces of concrete, brick, etc.

2. Make your cuts in the order shown in Figure 4, starting with cut 1 (base horizontal cut) and proceeding with the remaining three cuts.

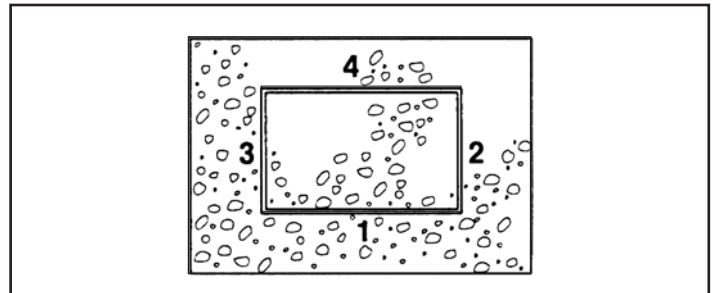

Figure 4. Planning Cuts

3. Outline the concrete area with a permanent marker for a visual guide.
4. Know what kind of material and how much reinforcing you are going to cut.

NOTICE

The following are general cutting procedures and techniques. Differences in the terrain and the type of material being cut will make this information more or less valid for particular areas. For advice on specific cutting problems or techniques, consult your local Stanley Representative. He/she can often provide information that will make your work safer and more productive.

OPERATION

TYPES OF CUTS

The DS06 can be operated using the types of cuts shown in Figure 5. When making cuts:

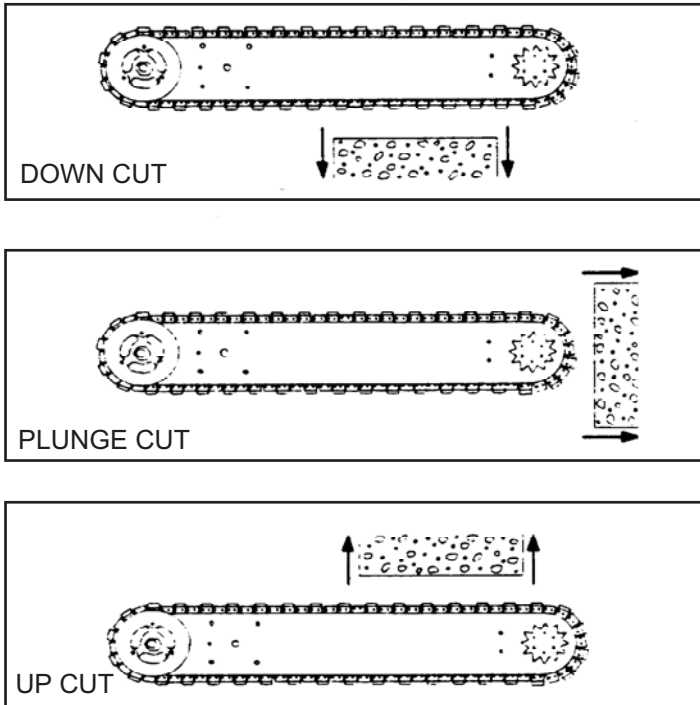

Figure 5. Types of Cuts (chain guard removed for clarity)

1. Do not use a cutting force in excess of 45 lbs/20 kg. Excessive force causes the chain to slow down or stall and causes premature wear of the saw bar and chain.
2. Always maintain a high chain speed. High chain speeds produce the best results.
3. Always check that plenty of water is being expelled from the bar and chain. When the tool is running, water is directed to the interior of the bar and then out of several holes located along the top and bottom channels on the bar. If these holes become plugged, cutting debris will not be adequately washed away and will result in premature wear of the bar and chain.
3. Avoid aggressive/heavy plunge forces. Aggressive plunge force creates fragmenting of the concrete when the saw bar and chain exits and causes premature bar and chain wear.

COLD WEATHER OPERATION

If the saw is to be used during cold weather, preheat the hydraulic fluid at low power source speed. When using the normally recommended fluids, fluid should be at or above 50°F/10°C (400 ssu/82 centistokes) before use.

Damage to the hydraulic system or chain saw can result from use with fluid that is too viscous or thick.

USING THE WALL WALKER™

The Wall Walker™ lessens operator fatigue and effort during cutting by automatic insertion of the wedge into the cut, thus allowing the operator to apply leverage to the saw.

1. Position the Wall Walker™ in the "autofeed" position by pinning the lever arm at the lowest hole as shown in the illustration.

Start cutting with the DS06 until the cut is large enough to allow the tip of the wedge to insert into the cut. With the tip of the wedge in the cut, the operator can easily apply leverage to the saw which will aid the cutting process and lessen operator fatigue and effort.

After the saw cuts approximately 1 to 2.5 in. / 25 to 65 mm, withdraw the saw only enough to allow the lever arm and wedge to reposition. After repositioning, continue cutting.

2. The Wall Walker™ can be positioned to the "parked" position by pinning the lever arm at the upper most hole. In this position, the Wall Walker™ is used as a bucking cleat.

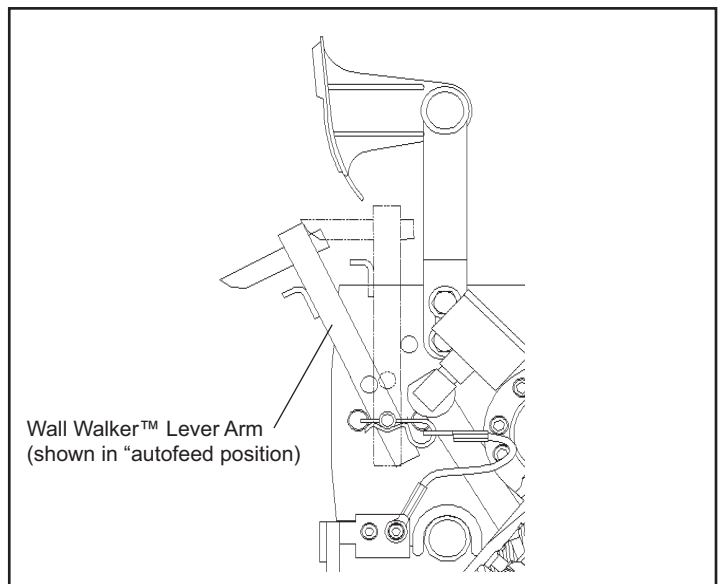

Figure 6. Wall Walker™

MAINTENANCE & ADJUSTMENTS

GENERAL MAINTENANCE TIPS

Several simple maintenance tasks which, if performed, can keep a chain saw operating at a high level of efficiency. Routine maintenance also keeps replacement costs down on the parts of the chain saw, which occasionally wear out.

If any chain saw disassembly is required, refer to the Service Manual.

SAW BAR RAIL

A quick check can be made to determine if saw bar rail or chain segment wear exists. Figure 7 shows a worn saw bar rail.

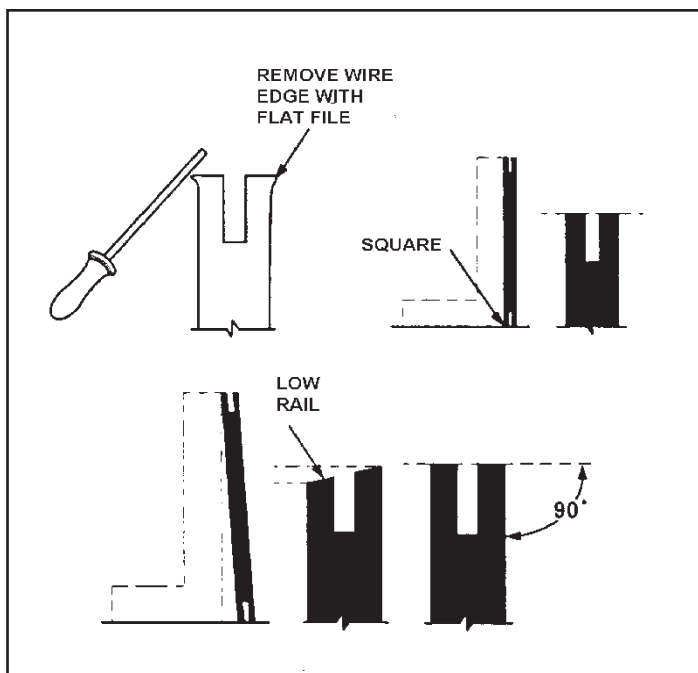

Figure 7. Rail Wear

If the saw bar rails are worn, use a flat file and dress each one until it is flat and square with the side of the saw bar (Figure 7).

Also make sure the saw bar is perfectly straight. If bows or bends are present in the saw bar, it must be replaced before dressing any rail.

ROTATING THE SAW BAR

Maximum saw bar life can be achieved by occasionally turning the bar over so the top and bottom bar surfaces wear evenly. Refer to the saw bar disassembly procedures in the Service Manual for further details.

CHAIN TENSION ADJUSTMENT

Correct chain tension is very important throughout the life of the chain. Check the chain tension often during use (when the chain saw is stopped and the saw bar and chain have cooled off). The chain should move easily around the saw bar when pulled by hand. To adjust the chain tension:

1. Turn off the water and power supplies.
2. Loosen the two saw bar attachment nuts (Figure 8).

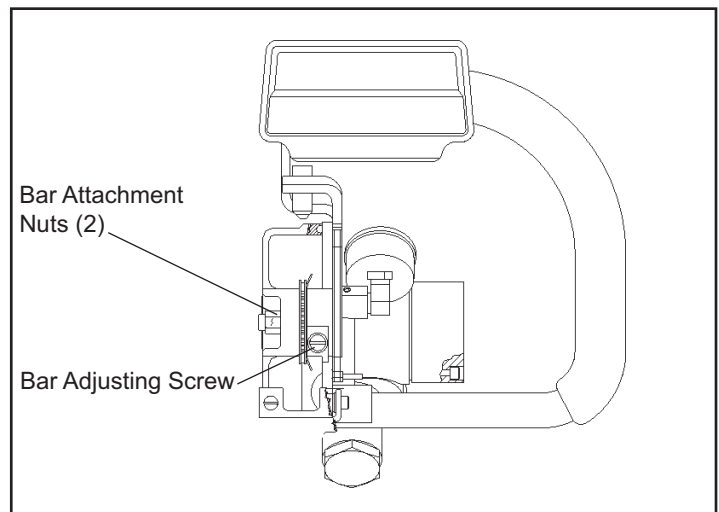

Figure 8. Attachment Screw Locations

3. Using the saw bar adjustment screw (Item 68, Parts Illustration), tighten the chain until you are still able to rotate it one full revolution by hand (Figure 9).

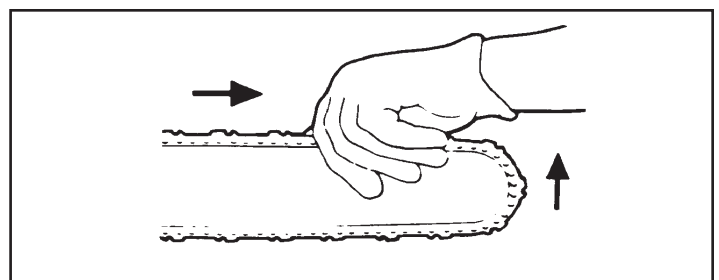

Figure 9. Pulling the Chain

4. Pull the chain around the saw bar to make sure it properly fits the sprocket and saw bar. The chain should be easily pulled.
5. Fully tighten the two saw bar attachment nuts (Figure 8).

Note:

Adjust the chain tension each time the drive link tang hangs fully exposed from the groove at the bottom of the saw bar (Figure 10).

MAINTENANCE & ADJUSTMENTS

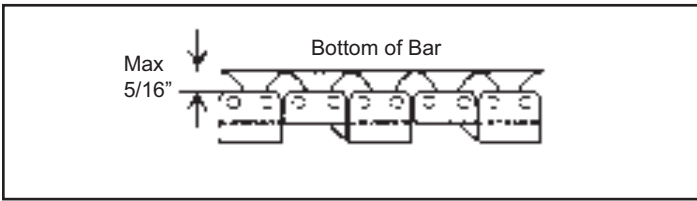

Figure 10. Exposed Drive Link Tang

SERVICING THE CHAIN

The following procedures explain how to break a chain using Stanley's bench mounted chain breaker (part number 20858) to remove a worn or damaged segment.

1. Mount the chain breaker flush with the side or front of a flat, clean work surface (Figure 11).

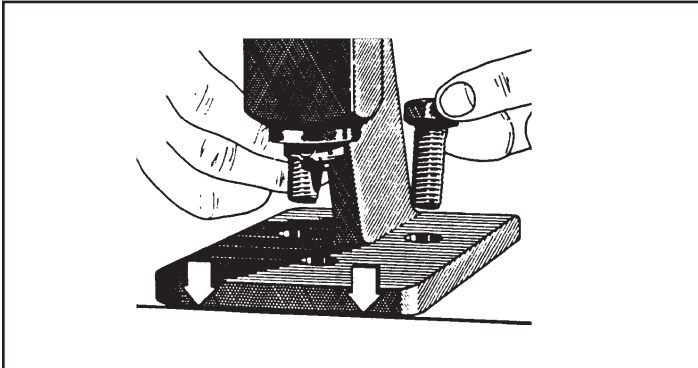

Figure 11. Chain Breaker Mounting

Note:

The Stanley chain breaker is only designed to remove rivet heads from the connecting links, not from a chain segment. The rivet heads shown in the shaded areas of Figure 12 are the only ones that can be removed.

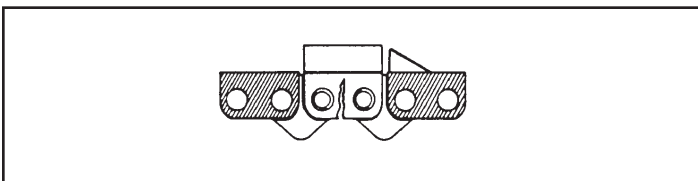

Figure 12. Removable Rivet Heads

2. Place the chain (the portion that you want broken) into the slot of the anvil pushing it forward until the bottom connecting link is flush with the far side of the slot (Figure 13).

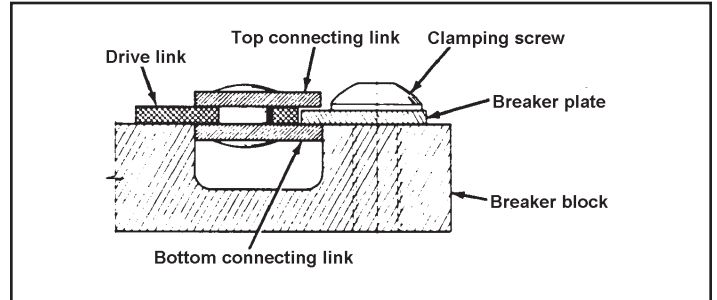
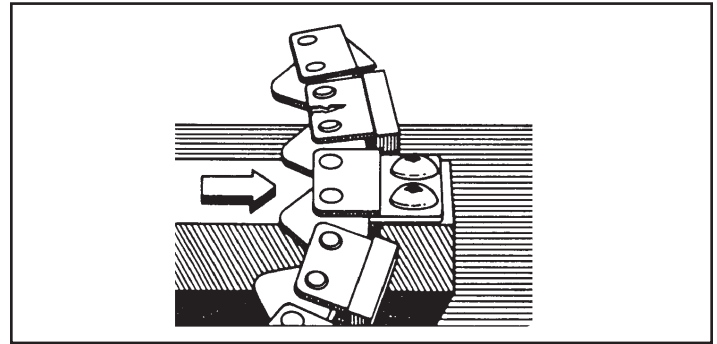

Figure 13. Inserting the Chain

3. Position the rivet head you want removed directly under the chainbreaker punch and then pull the handle down far enough to remove the rivet (Figure 14). Do not use excessive force.

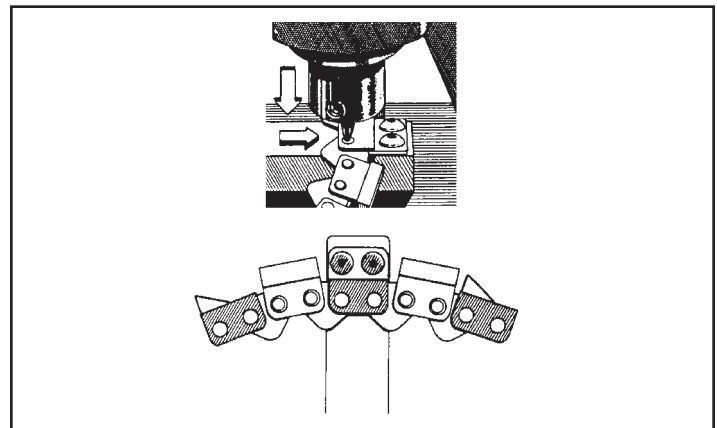

Figure 14. Removing a Rivet

MAINTENANCE & ADJUSTMENTS

REPLACING THE CHAIN BREAKER PUNCH

If the chain breaker punch (part number 22801) becomes worn or damaged, use the following procedures for replacement.

1. Remove the punch by loosening the set screw (Figure 15).

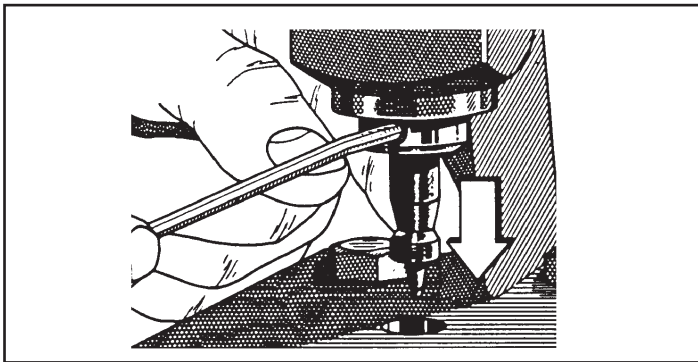

Figure 15. Removing the Punch

2. Insert a new punch into the holder and push it up until it is fully seated (Figure 16). Secure the punch to the chain breaker holder by fully tightening the set screw.

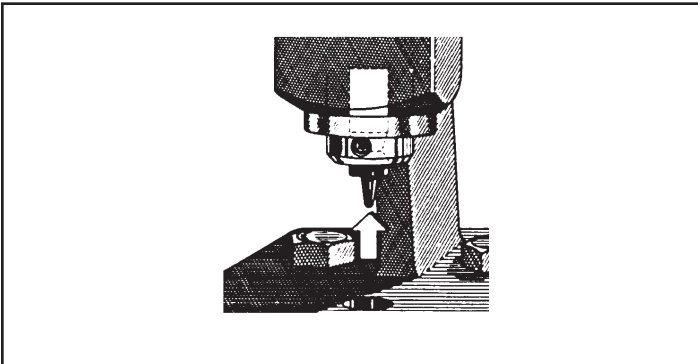

Figure 16. Replacing the Punch

SPINNING RIVETS

The following procedures explain how to spin rivets using Stanley's bench-mounted rivet spinner (part number 20857) to assembly the chain.

1. Mount the rivet spinner flush with the side or front of a flat, clean work surface (Figure 17).

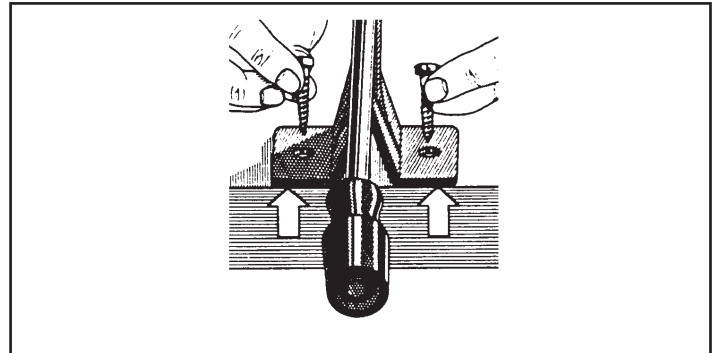

Figure 17. Rivet Spinner Mounting

2. Lay the chain across the plastic chain supports and then rotate the supports so the rivet head is centered between the take-up handle pocket and the spinner anvil (Figure 18).

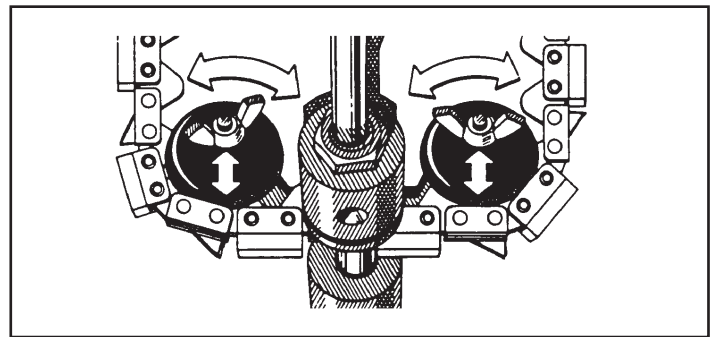

Figure 18. Positioning the Chain

3. Turn the take-up handle until the chain is tight against the spinner anvil (Figure 19).

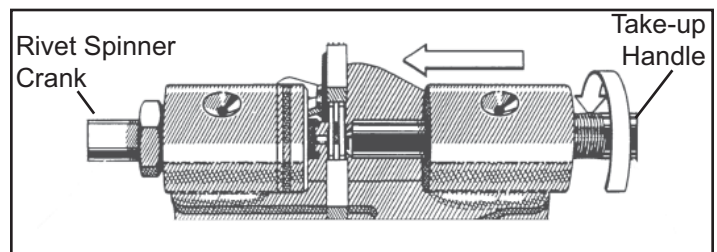

Figure 19. Securing the Chain

MAINTENANCE & ADJUSTMENTS

4. turn the rivet spinner crank a few times to center the rivet hub in the spinner anvil (Figure 20).

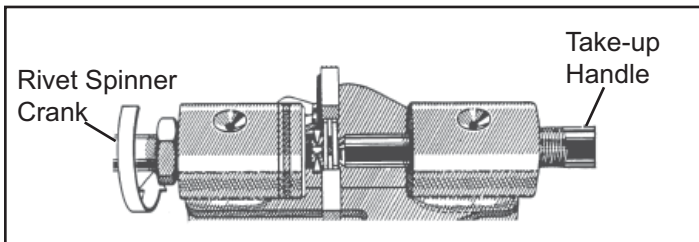

Figure 20. Centering the Rivet Hub

5. Apply a few drops of oil to the rivet hub (Figure 21).

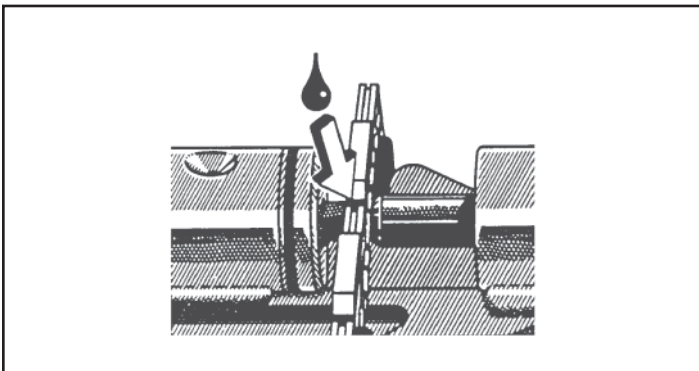

Figure 21. Applying the Oil

6. Turn the spinner crank while slowly running the take-up handle inward (approximately one full revolution) until the rivet head is formed (Figure 22).

Note:

The take-up handle provides pressure while the spinner anvil forms the rivet head.

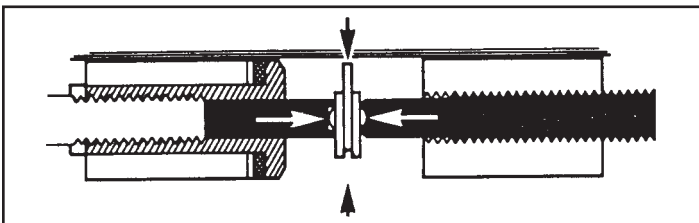

Figure 22. Forming a Rivet Head

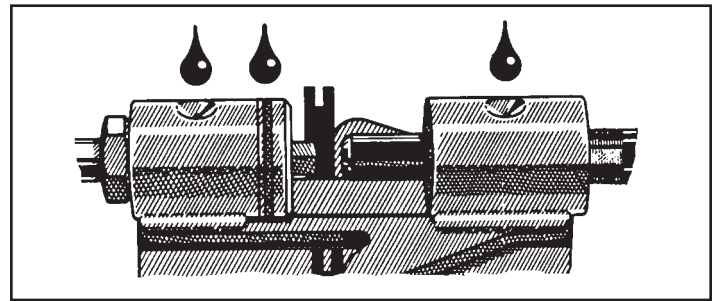

Figure 23. Spinner Oiling Chambers

NOTE:

the rivet spinner is equipped with oiling chambers and should be maintained periodically with a light-weight oil (Figure 23).

NOSE SPROCKET DISASSEMBLY AND ASSEMBLY

1. Using the bench mounted chain breaker (see accessories), line up the 1/4 inch hole in the side of the chain breaker anvil with the chain breaker punch. Punch out the six nose sprocket rivets. See Figure 24.

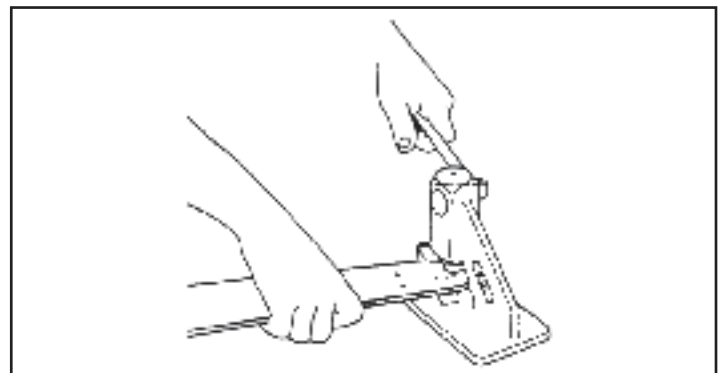

Figure 24. Punching Out Nose Sprocket Rivets

2. Insert a straight blade screw driver to spread the bar nose rails just enough to remove the old nose sprocket. Use a rag or paper towel to clean the nose sprocket area. See Figure 25.

MAINTENANCE & ADJUSTMENTS

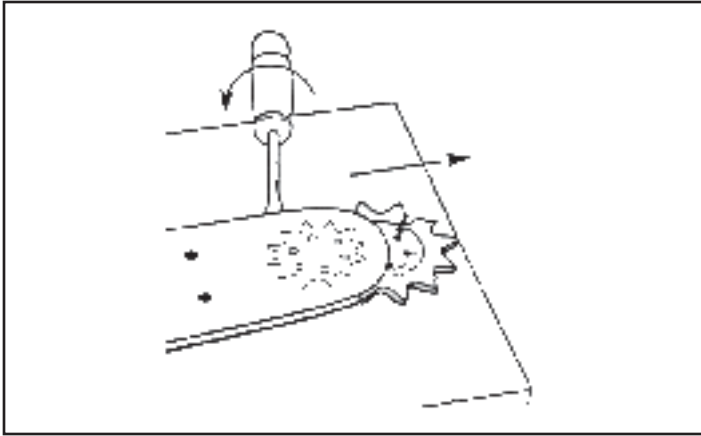

Figure 25. Removing Old Nose Sprocket

3. Remove the new nose sprocket package's clips and fold back the top portion of the insertion card being careful not to remove or disturb the components. See Figure 26.

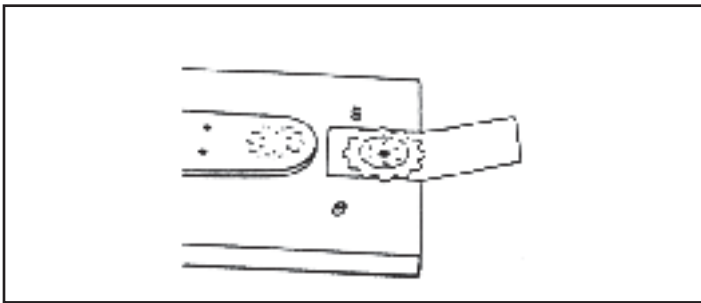

Figure 26. Preparing New Nose Sprocket

4. With a flat blade screw driver in the bar nose rails, slide the nose sprocket assembly into position aligning the 6 holes in the bar nose with the 6 holes in the nose sprocket assembly without removing the components from the card. See Figure 27.

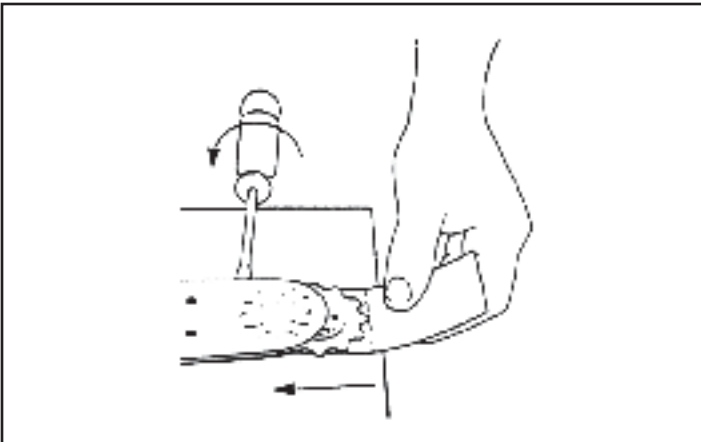

Figure 27. Installing a New Nose Sprocket

5. Insert 6 nose rivets into the holes and then hold them with your thumb. Remove the screwdriver and slide out the insertion card.

Note: On used bars the nose rails might tend to spread apart. Use a small clamp if necessary to hold the rails together.

6. With the bar and rivets solidly supported on a strong flat steel surface, carefully peen the rivet heads down with the flat end of a hammer. Be careful to only hit the rivet head. Do not hit the bar body; this will pinch the nose sprocket. Rivet heads must completely fill the countersinks in the bar body and be snug and secure while still allowing the sprocket to freely turn. See Figure 28.

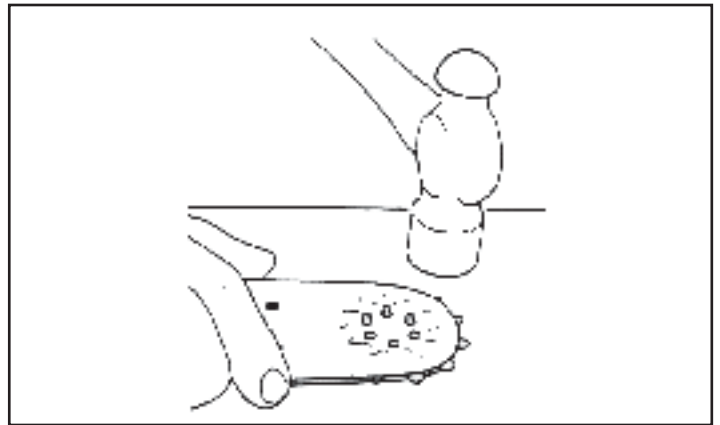

Figure 28. Replacing Rivets

7. Using a flat file, shave the rivet heads to a uniform height that is as close to the bar body as possible. See Figure 29.

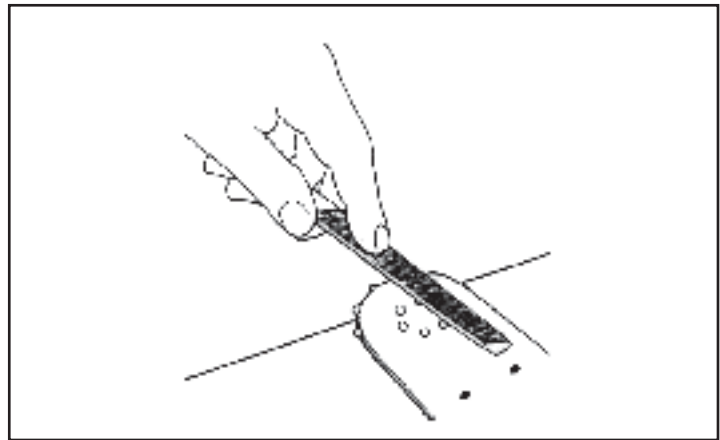

Figure 29. Filing Rivets

TOOL EQUIPMENT & CARE

NOTICE

In addition to the Safety Precautions in this manual, observe the following for equipment protection and care.

- Make sure all couplers are wiped clean before connection.
- The hydraulic circuit control valve must be in the “OFF” position when coupling or uncoupling hydraulic tools. Failure to do so may result in damage to the quick couplers and cause overheating of the hydraulic system.
- Always store the tool in a clean dry space, safe from damage or pilferage.
- Make sure the circuit PRESSURE hose (with male quick disconnect) is connected to the “IN” port. The circuit RETURN hose (with female quick disconnect) is connected to the opposite port. Do not reverse circuit flow. This can cause damage to internal seals.
- Always replace hoses, couplings and other parts with replacement parts recommended by Stanley Hydraulic Tools. Supply hoses must have a minimum working pressure rating of 2500 psi/172 bar.
- Do not exceed the rated flow (see Specifications) page in this manual for correct flow rate and model number. Rapid failure of the internal seals may result.
- Always keep critical tool markings, such as warning stickers and tags legible.
- Tool repair should be performed by experienced personnel only.
- Make certain that the recommended relief valves are installed in the pressure side of the system.
- Do not use the tool for applications for which it was not intended.

TROUBLESHOOTING

If symptoms of poor performance develop, the following chart can be used as a guide to correct the problem.

When diagnosing faults in operation of the tool, always check that the hydraulic power source is supplying the

correct hydraulic flow and pressure to the tool as listed in the table. Use a flowmeter known to be accurate. Check the flow with the hydraulic oil temperature at least 80°F/27°C.

SYMPTOM	CAUSE	REMEDY
Tool does not run.	Hydraulic power source not functioning correctly.	Check power source for proper flow and pressure (7-9 gpm/26-34 lpm at 2000 psi/140 bar.
	Coupler or hoses blocked.	Remove obstruction.
	Mechanical failure.	Have tool serviced by authorized dealer.
Tool runs backwards.	Pressure and return lines incorrectly connected.	Correct hose connections. Motor shaft rotates counterclockwise as viewed from the end of the motor shaft.
Diamond saw cuts slow.	Insufficient fluid flow or too high back pressure or relief valve set too low.	Check hydraulic supply. If hydraulic supply is correct, have unit serviced by authorized dealer.
	Back pressure too high.	Should not exceed 250 psi/17 bar at 9 gpm/34 lpm measured at the end of the tools operating hoses.
	Loss of diamond segment side clearance.	Replace chain.
	Chain segment dulled because of continuous use in hard material or rebar.	Redress segmented by cutting in abrasive material (i.e. concrete, building block, etc.). Note: This indicates that the wrong chain is being used.
	Wrong chain for application.	Scale down to a lower numbered chain.
	Wired edged bar rails.	Dress rails square.
	Hydraulic fluid mixed in water supply.	Have tool serviced.
Excessive vibration and cuts rough.	Segment(s) broken or missing.	Repair broken segment or replace chain.
	Chain installed backwards.	Correct chain direction.
	Loose chain tension.	Retension the chain.
	Excessive feed force.	Reduce feed force.
Will not cut straight.	Accumulated saw bar wear and uneven chain segment profile wear.	Turn the saw bar over and dress rails square. Replace the saw bar and chain.
Loss of power.	Drive sprocket slipping on Trantorque® adapter.	Adjust and tighten Trantorque® adapter to 17 ft lb/23 Nm.
Trigger hard to press.	Pressure & return hose reversed.	Connect for proper flow direction. Motor shaft must rotate clockwise.
	Back-pressure too high.	Should not exceed 250 psi/17 bar @ 9gpm/34 lpm measured at the end of the tool's operating hoses.

TROUBLESHOOTING

SYMPTOM	CAUSE	REMEDY
Leakage around drive sprocket.	Motor shaft seal failure.	Have unit serviced.
No water discharge at bar.	Blocked port(s) in bar.	Turn off hydraulic supply. Remove bar and chain and clean bar thoroughly. Blow ports with compressed air.
	Blocked inlet or outlet.	Turn off hydraulic supply. Remove bar and chain. Make sure water supply is on. Press trigger to see if water exits near bar adjustment nut area (a small port). If no water exits, have unit serviced.

SPECIFICATIONS

Cutting Depths.....	13 inches / 33 cm
Bar Lengths	13 inch / 33 cm
Chain Type	3/8 inch pitch with 21 diamond segments
Maximum Back Pressure	250 psi/17 bar
Input Flow Range	
5 gpm model.....	4-6 gpm / 15-23 lpm
8 gpm model.....	7-9 gpm/26-34 lpm
Input Pressure	2000 psi / 140 bar
Weight (without bar)	14 lbs / 6 kg
Length (without bar)	14.3 inches / 36 cm
Width	9 inches / 23 cm
Lubrication / Cooling.....	Internal Water Channels in Bar
Porting	-8 SAE O-Ring
Connection	EHTMA/HTMA Flush Face
Hose Whips	Yes
Chain Speed	
5 gpm model	4600 fpm/23.4 m/s
8 gpm model	5000 fpm/25.4 m/s

SOUND POWER AND VIBRATION DECLARATION	
Measured A-weighted sound power level, L _{wa} (ref. 1pW) in decibels	106.2 dBA
Uncertainty, K _{wa} , in decibels	3 dBA
Measured A-weighted sound pressure level, L _{pa} (ref. 20 µPa) at operator's position, in decibels	98.2 dBA
Uncertainty, K _{pa} , in decibels	3 dBA
Values determined according to noise test code given in ISO 15744, using the basic standard ISO3744 NOTE- The sum of a measured noise emission value and its associated uncertainty represents an upper boundary of the range of values which is likely to occur in measurements.	
Declared vibration emission value in accordance with EN 12096	
Measured vibration emission value: a	6.0 m/sec ²
Uncertainty: K	2.0 m/sec ²
Values determined according to ISO 8662-1, ISO 5349-1,2	

ACCESSORIES

Chain Repair Spinner	20857
Diamond Chain Repair Breaker	20858
Diamond Chain Service Kit	(sub p/n 20857 or 20858)
Diamond Chain Butterfly Repair Kit.....	20859
Water Pump Kit (115/230 Volt / 60 Hz).....	26020
Water Pump Kit (220/380/440 Volt /50 Hz).....	26237
HP1 Power Unit Water Pump Kit.....	29361
13 inch Bar, Sprocket Nose	35037
Ultra-25, Diamond Chain for 13 inch Bar	56799
Pinnacle-25, Diamond Chain for 13 inch Bar	56800
Water Pump Attachment for GT18 & HP1, with Couplers	HWP10
Water Flow Meter, 0-7 gpm	60859

SERVICE INSTRUCTIONS

PRIOR TO DISASSEMBLY

Clean exterior of the tool.

Obtain a seal kit so that all seals exposed during disassembly can be replaced.

ON-OFF VALVE SERVICING

TRIGGER (28) AND SAFETY CATCH (30) REMOVAL & INSTALLATION

1. Drive the roll pins (20) out of the handle assembly using a 3/16 in./4 mm diameter punch. Press the safety latch and remove the trigger (28).

NOTE: The safety catch can be removed at this time by driving out the 3/16 inch roll pin (21), but this is not necessary for servicing the on-off valve.

2. To install the trigger and safety catch reverse the above procedures.

VALVE SPOOL (14) REMOVAL & INSTALLATION

1. Remove the plug button (19) from the top of the handle by prying under the edge and then pulling it from the handle.

2. Drive the roll pins (20) out of the handle assembly using a 3/16 in./4 mm diameter punch. Press the safety latch and remove the trigger (28).

3. Drive the roll pin (20) (holding the valve spool (14) in place) out of the handle using a 3/16 in./4 mm diameter punch.

4. Unscrew the seal cap (44) and remove it, the spring (42), and the steel ball (41).

5. Lift out the valve spool assy (14 thru 18).

6. Using a 1/2 in./12.7 mm diameter wood dowel, place the dowel into the valve spool bore from the plug button (19) end of the handle. Push the dowel against the water valve sleeve (38) to push the water sleeve out.

REASSEMBLY

1. Inspect the spool bore of the handle and the outer surfaces of the spool for damage. **Some light surface scratches will be noticeable. Grooves, roughness or**

a reduced diameter indicate fluid contamination. If abnormal wear is present (more than normal polishing), replace both the spool and the handle.

2. Apply grease and install a new o-ring (15) onto the ON/OFF valve (14).

3. Apply grease and install new o-rings (34 & 35) into the spool bore of the handle.

4. Apply grease and install new o-rings (37 & 39) onto the water valve sleeve (38).

5. If the spring retainers (16) and spring (17) were removed from the ON/OFF valve, reinstall them. Lubricate the ON/OFF valve with hydraulic fluid and install it into the valve handle. Secure it in place with the roll pin (20).

6. Install the water valve sleeve into the valve handle.

7. Install the push pin (40), steel ball (41), spring (42), and seal cap (44). Make sure a new o-ring (43) is installed onto the seal cap.

8. Install the safety catch (30) making sure the spring (29) is positioned properly. Make sure the pin (33) is in place. Secure the safety catch with the roll pin (21).

9. Install the trigger (28) and secure with the roll pin (20).

10. Replace the plug button (19) and test the action of the safety catch and trigger.

FLOW CONTROL

Note:

Diamond saws with a serial number of 357 and above, no longer require a flow control.

The flow control (32) is factory preset and is not field serviceable. Use the following as guides to check for proper regulated flow.

For 5 gpm model:

If the regulated flow is over 6.6 gpm or under 5.4 gpm at 8 gpm input, the flow control valve should be replaced.

For 8 gpm model:

If the regulated flow is over 10 gpm or under 8 gpm at 12 gpm input, the flow control valve should be replaced.

SERVICE INSTRUCTIONS

MOTOR SERVICING

1. Remove the 2 nuts (51) and then lift off the chain guard (50).

2. Lift off the bar (61) and chain (73). If it is necessary to take tension off the bar and chain, turn the screw (68) counter clockwise.

For Diamond Saws with Serial Number 357 and above, follow the steps a thru c, then proceed to Step 7.

a. Remove the e-clip (60) and slide off items 48, 49 and 58.

b. Remove the retaining ring (100) and then spacer (47).

c. Remove the retaining ring (98) and then items 93 thru 96.

For Diamond Saws with Serial Number 356 and below, follow the steps below.

3. Slide the sprocket wrench (84) over the sprocket (48). While gripping the sprocket wrench and using an open end wrench, turn the hex head on the Trantorque™ adapter cap (49) counter clockwise until the Trantorque™ adapter can be removed from the motor shaft (53).

4. Remove the spacer (47), support washer (100), and o-ring (97).

5. Remove the retaining ring (98).

6. Remove the capscrews (1).

7. Using a flat-blade screwdriver or similar tool, gently pry the gear housing (4) away from the valve handle (22). Lift the gear housing straight up. **Do Not** tilt the housing or pry on the flat surface inside of the surrounding groove. For prying, only use the groove provided at the split between the parts to prevent scratches on the inner mating surfaces.

8. Remove the two gears (9 & 13), needle roller (54), and the idler shaft (8).

9. Remove the large face seal o-ring (7) while being careful not to damage the o-ring groove or surrounding surface.

10. While protecting the motor surface of the valve handle from damage, tap lightly on the small diameter end (*gear side*) of the motor shaft to remove it and the seal washer (94), seal ring (96), v-ring seal (95), o-ring (93), and bearing (92) from the front of the valve handle. Remove the seal keeper, seal spacer, seal, and o-ring from the motor shaft.

11. To remove the bearing from the shaft, press on the outside end (sprocket end) of the motor shaft while supporting the outer race of the bearing. Discard the old bearing.

12. Remove the retaining ring (91) at the bottom of the bearing bore. Remove the seal backup washer (57). Remove the quad ring (90) and o-ring (56) using the appropriate o-ring service tools. Discard the quad ring and o-ring.

13. The bushings (6) can be removed using p/n 11930 collet from p/n 05064 bearing puller kit.

MOTOR INSPECTION AND CLEANING

Inspect and clean all parts as follows:

CLEANING

Clean all parts with a degreasing solvent. Blow dry with compressed air and wipe clean. Use only lint-free cloths.

GEAR HOUSING

The chamber bores and bottoms around the shaft bushings should be polished and not rough or grooved. If the bushing bores are yellow-bronze, replace them and investigate the cause of wear.

The flat surfaces around the chamber and bolt holes should be flat and free of nicks or burrs that could cause misalignment or leaks.

BUSHINGS

The inside of the bushings should be gray with some bronze showing through. If significant yellow-bronze shows, replace the bushings. Inspect motor shaft for corresponding wear and replace as required.

GEARS

The drive and idler gears should have straight tips without nicks, square tooth ends and a smooth even polish on the teeth and end faces. Check for cracks between the drive gear keyway and gear tooth root. Replace the gear if cracks are present.

VALVE HANDLE MOTOR SURFACE

The surface near the gears should show two interconnecting polished circles without a step. The bottom of the o-ring

SERVICE INSTRUCTIONS

groove should be smooth as should the rest of the flat surface.

The bore for the shaft seal should be smooth or oil leakage may occur.

GEAR HOUSING

Shake the gear housing and the two seal check balls (not shown) should rattle. If the seal balls do not rattle then they are probably plugged with contaminants and the gear housing will require replacement.

SHAFTS

The shaft diameter at the bearing and seal locations must be smooth. Grooves, roughness or a reduced diameter indicate fluid contamination or damaged bushings. Grit particles may have been imbedded in the bushings grinding into the hardened shaft. If abnormal shaft wear as above occurs (more than normal polishing), replace both the shaft and associated bushings.

Also check the hydraulic system for excess contamination in the fluid and for filter condition. Operating conditions may require changing from a 25-micron filter to an oversized 10-micron filter.

MOTOR REASSEMBLY

Refer to the illustration below for correct placement of parts.

1. If the bushings (6) were removed from the valve handle (22) and the gear housing (4), install new bushings using a p/n 11918 bearing pusher. (NOTE: The bushing split line must face the center of the gear housing).

Serial Number 356 and Below.

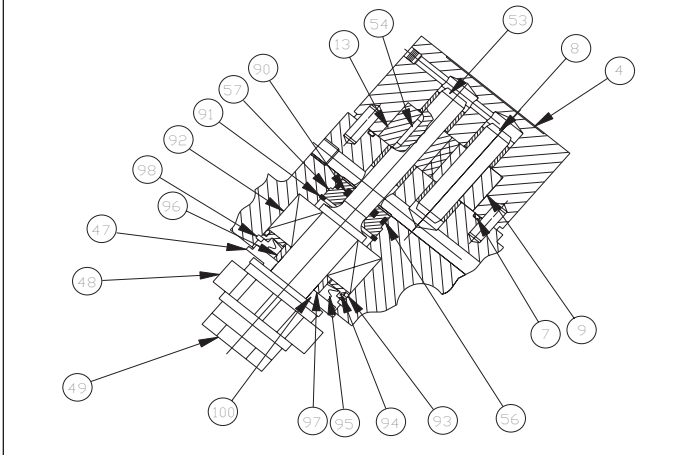

Serial Number 357 and Above.

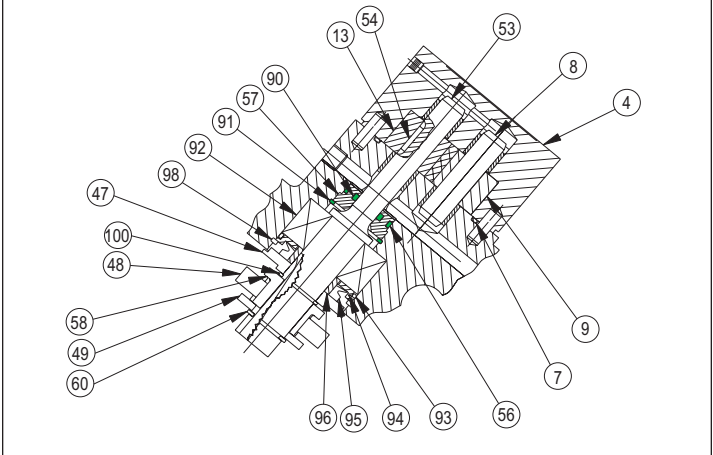

2. Grease and carefully install a new quad ring (90) into the seal liner (57). Grease and install a new o-ring (56) onto the seal liner. Install the seal liner into the valve handle assy (22). Replace the retaining ring (91).

3. To replace the bearing (92) onto the motor shaft (53), support the bearing inner race and press the motor shaft through the bearing inner race.

4. Place the valve handle assy on a smooth clean arbor press surface (protected from damage) with the large bearing bore facing up. Position the valve handle so a clearance hole exists for the insertion of the motor shaft.

5. Apply grease to the motor shaft, keyway and bushing and then insert the motor shaft through the shaft seal. Using a socket with a diameter equal to the bearing O.D., press the bearing and motor shaft into place. Press only on the outer race.

6. Install the needle roller (54) in the keyway of the motor shaft. Use grease to keep the needle roller in place. Slide the drive gear (13) over the needle roller and shaft. Install the idler shaft (8) and gear (9).

7. Apply grease to the face seal o-ring groove; then install the o-ring (7).

8. Note the screw hole pattern on the rear gear housing and the valve handle. They will only assemble one way. With all parts aligned, carefully slide the gear housing assembly over the gears until it contacts the valve handle. **Do not force parts together.**

9. Turn the motor shaft manually to check for free rotation. Install the eight capscrews (1) and then recheck rotation.

SERVICE INSTRUCTIONS

For Diamond Saws with Serial Number 357 and above follow steps a thru e.

For Diamond Saws with Serial Number 356 and below, follow steps 10 thru 13.

a. Install the o-ring (43). Push in until it contacts the bearing face.

b. Install seal washer (94) and the retainer ring (98).

c. Install v-ring (95) onto seal ring (96) then with both in hand, apply a small amount of 242 Loctite™ to the bore of the seal ring (96). Make sure it is applied around the entire bore of the seal ring, then slide both parts onto the motor shaft.

d. Install the seal spacer (47) and then the retainer ring (100).

e. Install items 58, 48, 49 and e-clip (60).

10. Apply grease and install a new v-ring seal (95) into the seal washer (94). Apply grease and install a new o-ring onto the seal keeper. Insert the seal ring (96) into the seal washer and then install the seal spacer and seal keeper onto the motor shaft as an assembly. Press the assembly against the bearing and then install the retaining ring (98).

11. Apply grease and install a new o-ring (97) onto the motor shaft. Slide the o-ring against the seal spacer. Install the spacer (47) and support washer (100).

12. Install the sprocket (48) over the Trantorque™ adapter cap (49) and then install this assembly onto the motor shaft. While gripping the sprocket, hand tighten the hex head of the Trantorque™ adapter cap by turning it clockwise.

13. Slide the sprocket wrench (84) over the sprocket (48). While gripping the sprocket wrench and using an open end wrench, tighten the hex head on the Trantorque™ adapter (49) clockwise to 17 lb. ft./23 Nm.

4. Place the bar (with chain) over the studs making sure the chain is looped around the sprocket and the bar adjustment nut is seated in the hole on the bar. While holding the bar and chain in place, turn the adjustment screw (68) clockwise to take the slack out of the chain. Install the chain guard (50) and the 2 nuts (51). Hand tighten the 2 nuts and then back them off 1/4 turn.

5. Adjust the chain tension by turning the adjustment screw (68) in accordance with the instructions contained in the section titled "MAINTENANCE & ADJUSTMENTS".

6. When adjustments are completed, be sure to tighten the nuts (51).

BAR & CHAIN AND CHAIN GUARD ASSEMBLY

1. Back the bar adjustment nut (70) off by turning the adjustment screw (68) counter clockwise.

2. Install the chain (73) onto the bar (61). Make sure the chain is installed so that the bumper guards precede the segments. See the section titled 'OPERATION".

3. Install the chain guide plate (65) over the stud (66) as shown in the parts illustration.

DS06 PARTS ILLUSTRATION

For Serial Numbers
357 and Above.

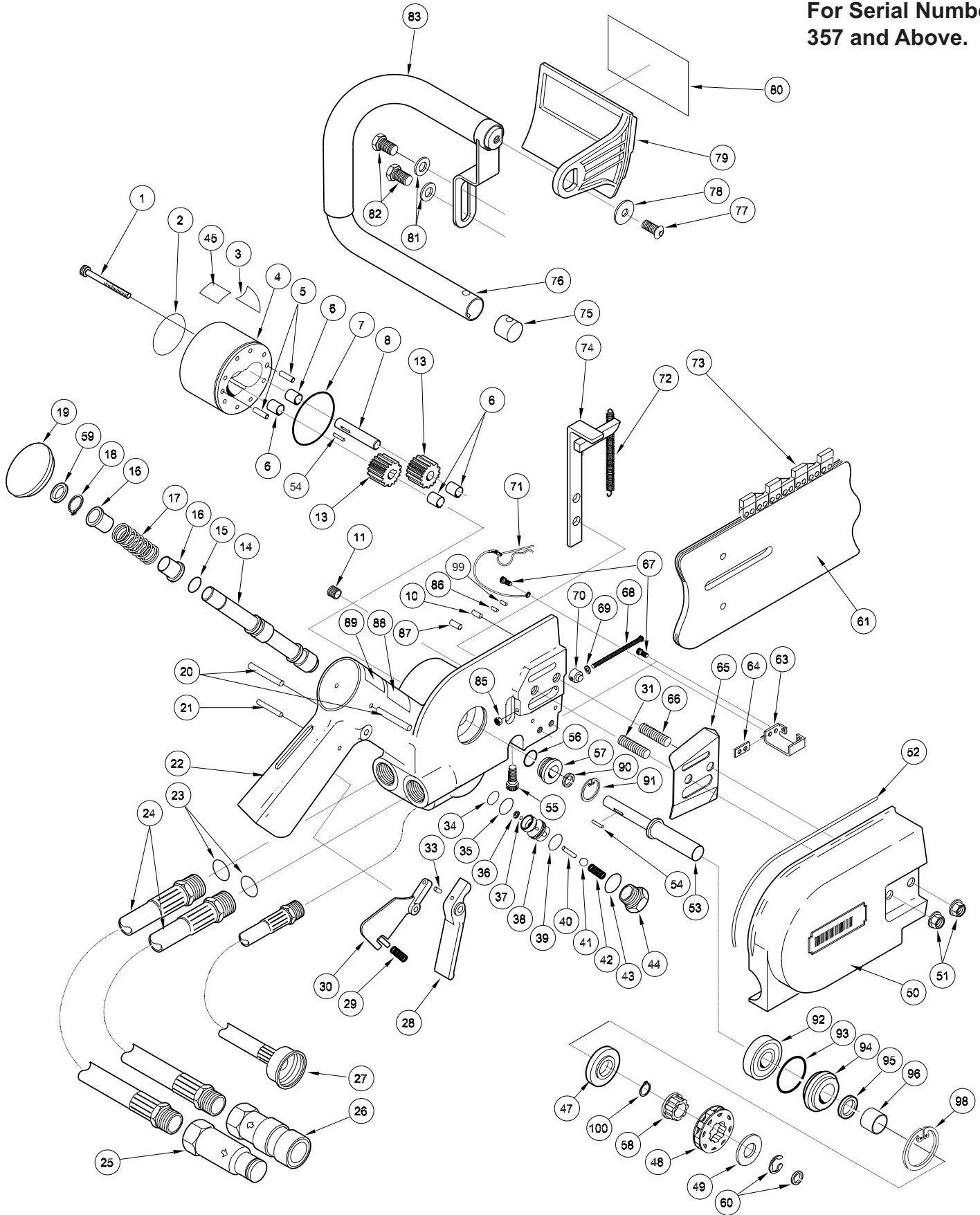

DS06 PARTS LIST

For Serial Numbers
357 and Above.

Item No.	Part No.	Qty	Description	Item No.	Part No.	Qty	Description
1	00753	8	SHSCS 10-24 UNC x 1-1/4	56	60804	1	O-Ring
2	33445	1	Name Tag	57	19215	1	Seal Back-Up Washer
3	11207 11206	1	Circuit "D" Decal (8 gpm Model) Circuit "C" Decal (5 gpm Model)	58	43689	1	Sprocket Adapter
4	07652	1	Rear Gear Housing Assy. (Incl. Items 5-6), 8 gpm Model Only	59	58969	1	Wiper Seal
	07834	1	Rear Gear Housing Assy. (Incl. Items 5-6), 5 gpm Model Only	60	41763	1	E-Clip (For DS063000 s/n 434 and below and for DS06200001 s/n 110 and below)
5	00289	2	Dowel Pin		66299	1	Spiral Retainer Ring (For DS063000 s/n 435 and above and for DS06200001 s/n 111 and above)
6	04041	4	Bushing	61	---	-	Saw Bar (See Accessories)
7	00020	1	O-Ring	62	---	-	No Item
8	07612	1	Idler Shaft	63	32196	1	Flap Mount
9	---	-	No Item	64	33219	1	Spacer
10	32190	1	Pivot Pin	65	32192	1	Chain Guide Plate
11	00961	1	Pipe Plug	66	32245	1	Stud (Supplied with Item 22)
12	---	-	No Item	67	58968	2	SHSCS 1/4 -20 UNC x 5/8
13	04106 07832	2	Drive Gear, 8 gpm Model Only Drive Gear, 5 gpm Model Only	68	02687	1	Machine Screw
14	32207	1	On/Off Valve	69	32191	1	Stat-O-Seal
15	07626	1	O-Ring	70	32198	1	Bar Adjustment Nut
16	07609	2	Spring Washer	71	33481	1	Wall Walker Clevis Pin
17	34119	1	Spring	72	---	-	Spring (Incl. with Item 74)
18	04512	1	Retaining Ring, 1/2 EX	73	---	-	Chain (See Accessories)
19	07625	1	Plug Button	74	32206	1	Wall Walker
20	03009	2	Roll Pin	75	02649	1	Handle Bar Retainer
21	07624	1	Roll Pin, 3/16 x 1	76	33229	1	Handle Weldment
22	33267	1	Valve Handle Assy. (Incl. Items 6, 31, 66)	77	33260	1	BHCS 1/4 -20 x .625 Zinc
23	01605	-	O-Ring, (Supplied with Item 24)	78	33261	1	Fender Washer
24	01652	2	Pigtail Hose Assy.	79	33258	1	Hand Guard
25	24059	1	Male Coupler	80	12412	1	Electrical Warning Decal
26	24058	1	Female Coupler	81	12175	2	Washer
27	33443	1	Water Hose Assy.	82	33454	2	HHCS 5/16 -18 x 5/8 Zinc
28	58879	1	Trigger	83	33263	1	Handle Grip
29	07602	1	Spring	84	---	-	No Item
30	34105	1	Safety Catch	85	17134	1	Nut, 1/4 -20 HHD LT SST
31	32197	1	Stud (Supplied with Item 22)	86	31614	1	Spirol Pin
32	---	-	No Item	87	30635	1	Spirol Pin, 5/16 x 7/8
33	00072	1	Roll Pin	88	28409	1	Composite Decal (CE)
34	07627	1	O-Ring	89	11212	1	Sound Power Level Decal (CE)
35	00074	1	O-Ring	90	00173	1	Quad Ring
36	33488	1	Self Locking Retaining Ring	91	04856	1	Retaining Ring
37	05632	1	O-Ring	92	35965	1	Bearing
38	58970	1	Water Valve Sleeve	93	00621	1	O-Ring
39	01403	1	O-Ring	94	38897	1	Seal Washer
40	33380	1	Pin	95	39070	1	V-Ring
41	36259	1	Steel Ball, 3/8" Dia.	96	38700	1	Seal Ring
42	32188	1	Spring	97	---	-	No Item
43	04052	1	O-Ring	98	07324	1	Retaining Ring
44	32189	1	Seal Cap	99	37793	1	Extension Spring Anchor
45	28323	1	CE Decal	100	41764	1	Retaining Ring
46	---	-	No Item		03786	1	GPM Decal (8 gpm Models) (Not Shown)
47	38898	1	Seal Spacer		33360	1	SEAL KIT
48	09098	1	Sprocket				
49	41765	1	Washer				
50	32255	1	Chain Guard				
51	32203	2	Nut				
52	20721	1	Cord Stock, 3/16" Dia.				
53	43690	1	Motor Shaft (See Item #60 for Serial No. Break)				
54	04044	2	Needle Roller				
55	02688	1	SHSCS 5/16 -18 UNC x 3/4				

DS06 PARTS ILLUSTRATION

For Serial Numbers
356 and Below.

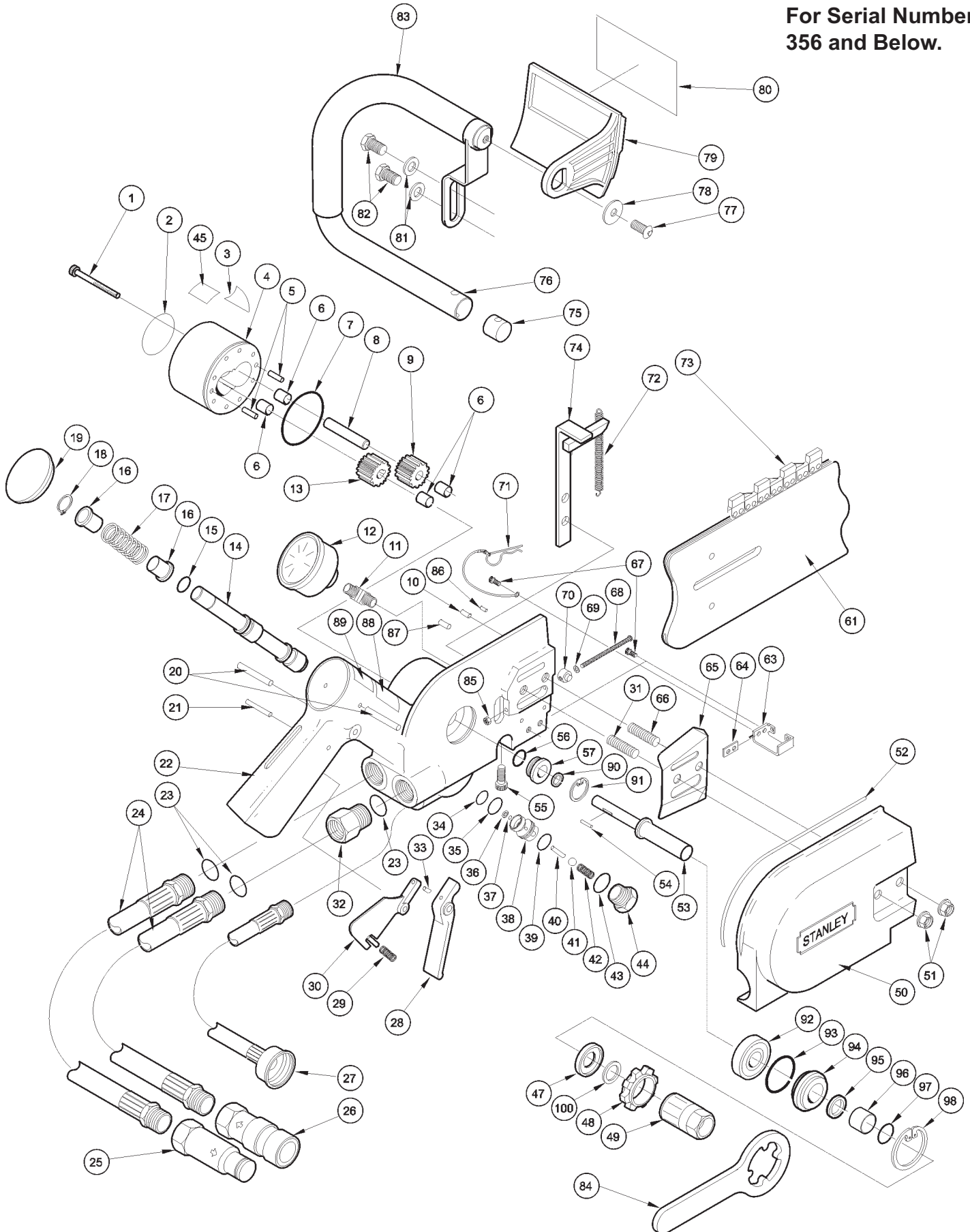

DS06 PARTS LIST

For Serial Numbers
356 and Below.

Item No	Qty	Part No.	Description
1	8	00753	HSCHS 10-24UNCx1-1/4
2	1	33445	NAME TAG
3	1	11207	CIRCUIT "D" STICKER (8 gpm model)
	1	11206	CIRCUIT "C" STICKER (5 gpm model)
4	1	07652	REAR GEAR HOUSING ASSY (INCLD ITEM 5 & 6), 8 gpm model only
	1	07834	REAR GEAR HOUSING ASSY (INCLD ITEM 5 & 6), 5 gpm model only
5	2	00289	DOWEL PIN
6	4	04041	BUSHING
7	1	00020	O-RING 5-329 R17 •
8	1	07612	IDLER SHAFT
9	1	04105	IDLER GEAR, 8 gpm model only
	1	07831	IDLER GEAR, 5 gpm model only
10	1	32190	PIVOT PIN
11	1	22716	ST ELBOW 1/8NPT
12	1	21550	WATER GAUGE
13	1	04106	DRIVE GEAR, 8 gpm model only
	1	07832	DRIVE GEAR, 5 gpm model only
14	1	32207	ON/OFF VALVE
15	1	07626	O-RING 2-014 R18 •
16	2	07609	SPRING WASHER
17	1	34119	SPRING
18	1	04512	RETAINING RING 1/2 EX
19	1	07625	PLUG BUTTON
20	2	03009	ROLL PIN
21	1	07624	ROLL PIN-3/16 X 1
22	1	32201	VALVE HANDLE ASSY (INCLD ITEMS 31 & 66)
23	3	01605	O-RING
24	2	01652	PIGTAIL HOSE ASSEMBLY
25	1	24059	MALE COUPLER
26	1	24058	FEMALE COUPLER
27	1	33443	WATER HOSE ASSY
28	1	34093	TRIGGER
29	1	07602	SPRING
30	1	34105	SAFETY CATCH
31	1	32197	STUD
32	1	33444	FLOW CONTROL VALVE, 8 gpm model only
	1	34006	FLOW CONTROL VALVE, 5 gpm model only
33	1	00072	ROLL PIN
34	1	07627	O-RING 2-016 R24 •
35	1	00074	O-RING 2-021 R16 •
36	1	33488	SELF LOCKING RETAINING RING
37	1	05632	O-RING 2-005 R16 •
38	1	33377	WATER VALVE SLEEVE
39	1	01403	O-RING 2-020 R16 •
40	1	33380	PIN
41	1	36259	STEEL BALL 3/8 DIA.
42	1	32188	SPRING
43	1	04052	O-RING 3-914 R17 •
44	1	32189	SEAL CAP
45	1	28323	CE STICKER
46	1	06635	RET RING 1 3/8 INT
47	1	38898	SEAL SPACER
48	1	32210	SPROCKET
49	1	39071	TRANTORQUE™ ADAPTOR
50	1	32255	CHAIN GUARD
51	2	32203	NUT
52	1	20721	CORD STOCK 3/16DIA R1
53	1	35897	MOTOR SHAFT
54	1	04044	NEEDLE ROLLER
55	1	02688	HSCHS 5/16-18UNCx3/4

Item No	Qty	Part No.	Description
56	1	60804	O-RING •
57	1	19215	SEAL LINER •
58	-	----	NO ITEM
59	-	----	NO ITEM
60	-	----	NO ITEM
61	-	----	SAW BAR (SEE ACCESSORIES)
62	-	----	NO ITEM
63	1	32196	FLAP MOUNT
64	1	33219	SPACER
65	1	32192	CHAIN GUIDE PLATE
66	1	32245	STUD
67	2	02446	HSCHS 1/4-20UNCx5/8
68	1	02687	MACHINE SCREW
69	1	32191	STAT-O-SEAL •
70	1	32198	BAR ADJUSTMENT NUT
71	1	33481	WALLWALKER CLEVIS PIN
72			SPRING (INCLD WITH ITEM 74)
73		----	CHAIN (SEE ACCESSORIES)
74	1	32206	WALL WALKER
75	1	02649	HANDLE BAR RETAINER
76	1	33229	HANDLE WELDMENT
77	1	33260	BHCS 1/4-20x.625 ZINC
78	1	33261	FENDER WASHER
79	1	33258	HAND GUARD
80	1	12412	WARNING STICKER-ELECT
81	2	12175	WASHER
82	2	33454	HHCS 5/16-18x5/8 ZINC
83	1	33263	HANDLE GRIP
84	1	33429	SPROCKET WRENCH
85	1	17134	NUT 1/4-20 HHD LT SST
86	1	31614	SPIROL PIN
87	1	30635	SPIROL PIN 5/16 x 7/8
88	1	28409	COMPOSITE STICKER (CE)
89	1	11212	SOUND POWER LEVEL STICKER (CE)
90	1	00173	QUAD RING •
91	1	04856	RETAINING RING
92	1	35965	BEARING
93	1	00621	O-RING •
94	1	38897	SEAL WASHER
95	1	39070	V-RING •
96	1	38700	SEAL RING
97	1	350810	O-RING
98	1	07324	RETAINING RING
99	-	----	NO ITEM
100	1	34118	SUPPORT WASHER
		33360	SEAL KIT

• Denotes Part in Seal Kit

DIAMOND CHAIN APPLICATIONS

Model	Bar Length	P/N	Correct Applications
Pinnacle- Pinnacle-	13 inch		Very hard aggregate concretes (flint, chert, granite, etc). Heavy steel reinforcing, 5/8 inch/16 mm diameter and larger. Medium/hard aggregate concretes (granite, quartz, river rock, etc). Moderate steel reinforcing (wire mesh 3/8-1/2 inch/10-12 mm diameter). Soft aggregate concrete, concrete block, masonry, "green" concrete, highly abrasive
Ultra- Ultra-	13 inch		Medium/hard aggregate concretes (granite, quartz, river rock, etc). Moderate steel reinforcing (wire mesh 3/8-1/2 inch/10-12 mm diameter). Soft aggregate concrete, concrete block, masonry, "green" concrete, highly abrasive conditions.

WARRANTY

Stanley Hydraulic Tools (hereinafter called "Stanley"), subject to the exceptions contained below, warrants new hydraulic tools for a period of one year from the date of sale to the first retail purchaser, or for a period of 2 years from the shipping date from Stanley, whichever period expires first, to be free of defects in material and/or workmanship at the time of delivery, and will, at its option, repair or replace any tool or part of a tool, or new part, which is found upon examination by a Stanley authorized service outlet or by Stanley's factory in Milwaukie, Oregon to be DEFECTIVE IN MATERIAL AND/OR WORKMANSHIP.

EXCEPTIONS FROM WARRANTY

FREIGHT COSTS: Freight costs to return parts to Stanley, if requested by Stanley for the purpose of evaluating a warranty claim for warranty credit, are covered under this policy if the claimed part or parts are approved for warranty credit. Freight costs for any part or parts which are not approved for warranty credit will be the responsibility of the individual.

SEALS & DIAPHRAGMS: Seals and diaphragms installed in new tools are warranted to be free of defects in material and/or workmanship for a period of 6 months after the date of first usage, or for a period of 2 years from the shipping date from Stanley, whichever period expires first.

CUTTING ACCESSORIES: Cutting accessories such as breaker tool bits are warranted to be free of defects in material and or workmanship at the time of delivery only.

ITEMS PRODUCED BY OTHER MANUFACTURERS: Components which are not manufactured by Stanley and are warranted by their respective manufacturers.

a. Costs incurred to remove a Stanley manufactured component in order to service an item manufactured by other manufacturers.

ALTERATIONS & MODIFICATIONS: Alterations or modifications to any tool or part. All obligations under this warranty shall be terminated if the new tool or part is altered or modified in any way.

NORMAL WEAR: any failure or performance deficiency attributable to normal wear and tear such as tool bushings, retaining pins, wear plates, bumpers, retaining rings and plugs, rubber bushings, recoil springs, etc.

INCIDENTAL/CONSEQUENTIAL DAMAGES: To the fullest extent permitted by applicable law, in no event will STANLEY be liable for any incidental, consequential or special damages and/or expenses.

FREIGHT DAMAGE: Damage caused by improper storage or freight handling.

LOSS TIME: Loss of operating time to the user while the tool(s) is out of service.

IMPROPER OPERATION: Any failure or performance deficiency attributable to a failure to follow the guidelines and/or procedures as outlined in the tool's operation and maintenance manual.

MAINTENANCE: Any failure or performance deficiency attributable to not maintaining the tool(s) in good operating condition as outlined in the Operation and Maintenance Manual.

HYDRAULIC PRESSURE & FLOW: Any failure or performance deficiency attributable to excess hydraulic pressure, excess hydraulic back-pressure, or excess hydraulic flow.

REPAIRS OR ALTERATIONS: Any failure or performance deficiency attributable to repairs by anyone which in Stanley's sole judgement caused or contributed to the failure or deficiency.

MIS-APPLICATION: Any failure or performance deficiency attributable to mis-application. "Mis-application" is defined as usage of products for which they were not originally intended or usage of products in such a manner which exposes them to abuse or accident, without first obtaining the written consent of Stanley.

WARRANTY REGISTRATION: STANLEY ASSUMES NO LIABILITY FOR WARRANTY CLAIMS SUBMITTED FOR WHICH NO TOOL REGISTRATION IS ON RECORD. In the event a warranty claim is submitted and no tool registration is on record, no warranty credit will be issued without first receiving documentation which proves the sale of the tool or the tools' first date of usage. The term "DOCUMENTATION" as used in this paragraph is defined as a bill of sale, or letter of intent from the first retail customer. A WARRANTY REGISTRATION FORM THAT IS NOT ALSO ON RECORD WITH STANLEY WILL NOT BE ACCEPTED AS "DOCUMENTATION".

NO ADDITIONAL WARRANTIES OR REPRESENTATIONS

This limited warranty and the obligation of Stanley thereunder is in lieu of all other warranties, expressed or implied including merchantability or fitness for a particular purpose except for that provided herein. There is no other warranty. This warranty gives the purchaser specific legal rights and other rights may be available which might vary depending upon applicable law.



Stanley Hydraulic Tools
3810 SE Naef Road
Milwaukie OR 97267-5698
503-659-5660
FAX 503-652-1780
www.stanley-hydraulic-tools.com

Free Manuals Download Website

<http://myh66.com>

<http://usermanuals.us>

<http://www.somanuals.com>

<http://www.4manuals.cc>

<http://www.manual-lib.com>

<http://www.404manual.com>

<http://www.luxmanual.com>

<http://aubethermostatmanual.com>

Golf course search by state

<http://golfingnear.com>

Email search by domain

<http://emailbydomain.com>

Auto manuals search

<http://auto.somanuals.com>

TV manuals search

<http://tv.somanuals.com>