

Line Thermal/Dot Printer

STAR Line Mode
Command Specifications

Rev. 0.00

Star Micronics Co., Ltd.
Special Products Operating Division

Contents

| | | |
|--------|--|------|
| 1. | GENERAL DESCRIPTION | 1-1 |
| 2. | COMMAND FUNCTION LIST | 2-1 |
| 3. | COMMAND DETAILS | 3-1 |
| 3-1) | Explanation of Terms | 3-1 |
| 3-2) | Exception processing | 3-2 |
| 3-3) | Standard Command Details | 3-3 |
| 3-3-1) | Font style and character set | 3-3 |
| | ESC RS F n | 3-3 |
| | ESC GS t n | 3-4 |
| | ESC GS = n1 n2 da1 da2 ... dak db1 db2 ... dbk | 3-5 |
| | ESC R n | 3-6 |
| | ESC / N | 3-7 |
| | ESC SP n | 3-7 |
| | ESC M | 3-8 |
| | ESC P | 3-8 |
| | ESC : | 3-9 |
| | ESC g | 3-9 |
| | ESC 6 | 3-10 |
| | ESC 7 | 3-10 |
| 3-3-2) | Character Expansion Settings | 3-11 |
| | ESC i n1 n2 | 3-11 |
| | ESC W n | 3-12 |
| | ESC h n | 3-13 |
| | SO | 3-14 |
| | DC4 | 3-14 |
| | ESC SO | 3-15 |
| | ESC DC4 | 3-15 |
| 3-3-3) | Print mode | 3-16 |
| | ESC E | 3-16 |
| | ESC F | 3-17 |
| | ESC - n | 3-18 |
| | ESC _ n | 3-19 |
| | ESC 4 | 3-20 |
| | ESC 5 | 3-20 |
| | ESC GS 4 m n | 3-21 |
| | SI | 3-23 |
| | DC2 | 3-23 |
| | ESC RS i n | 3-24 |
| 3-3-4) | Line Spacing | 3-25 |
| | LF | 3-25 |
| | CR | 3-25 |
| | ESC a n | 3-26 |
| | ESC z n | 3-27 |
| | ESC 0 | 3-27 |
| | ESC 1 | 3-28 |
| | ESC J n | 3-28 |
| | ESC j n | 3-29 |
| | ESC l n | 3-29 |
| | ESC A n | 3-30 |
| | ESC 2 | 3-30 |
| | ESC 3 n | 3-31 |
| | ESC y n | 3-31 |
| 3-3-5) | Page Control Commands | 3-32 |
| | FF | 3-32 |
| | ESC C n | 3-33 |
| | ESC C 0 n | 3-34 |
| | VT | 3-35 |
| | ESC B n1 n2 ... nk NUL | 3-36 |
| | ESC B NUL | 3-36 |
| 3-3-6) | Horizontal Direction Printing Position | 3-37 |
| | ESC l n | 3-37 |

| | |
|---|------|
| ESC Q n | 3-38 |
| HT | 3-39 |
| ESC D n1 n2 ... nk NUL | 3-39 |
| ESC D NUL | 3-40 |
| ESC GS A n1 n2 | 3-40 |
| ESC GS R n1 n2 | 3-41 |
| ESC GS a n | 3-42 |
| 3-3-7) Download | 3-43 |
| ESC & c1 c2 n d1 ... d48 | 3-43 |
| ESC & c1 c2 n | 3-44 |
| ESC & NUL n1 n2 [m d1 d2 d3 d4 d5 (d6 d7)] n2 - n1 + 1 | 3-45 |
| ESC % N | 3-47 |
| 3-3-8) Bit Image Graphics | 3-48 |
| ESC K n1 n2 d1 ... dk | 3-48 |
| ESC L n1 n2 d1 ... dk | 3-50 |
| ESC k n1 n2 d1 ... dk | 3-51 |
| ESC X n1 n2 d1 ... dk | 3-52 |
| ESC ^ m n1 n2 d1 d2 ... dk | 3-53 |
| 3-3-9) Logo | 3-54 |
| ESC FS q n [x11 x12 y11 y12 d1 ... dk]1 ... [xn1 xn2 yn1 yn2 d1 ... dk] n | 3-54 |
| ESC FS p n m | 3-56 |
| ESC RS L m | 3-57 |
| 3-3-10) Bar Codes | 3-58 |
| ESC b n1 n2 n3 n4 d1 ... dk RS | 3-58 |
| 3-3-11) Cutter Control | 3-60 |
| ESC d n | 3-60 |
| 3-3-12) External Device Drive | 3-61 |
| ESC BEL n1 n2 | 3-61 |
| BEL | 3-62 |
| FS | 3-62 |
| SUB | 3-63 |
| EM | 3-63 |
| ESC GS BEL m t1 t2 | 3-64 |
| ESC GS EM DC1 m n1 n2 | 3-65 |
| ESC GS EM DC2 m n1 n2 | 3-66 |
| 3-3-13) Print Settings | 3-67 |
| ESC RS d n | 3-67 |
| ESC RS r n | 3-68 |
| 3-3-14) Status | 3-69 |
| ESC RS a n | 3-69 |
| ESC ACK SOH | 3-70 |
| ENQ | 3-70 |
| EOT | 3-71 |
| ETB | 3-71 |
| ESC RS E n | 3-72 |
| 3-3-15) Kanji Characters | 3-73 |
| ESC p | 3-73 |
| ESC q | 3-73 |
| ESC \$ n | 3-74 |
| ESC s n1 n2 | 3-75 |
| ESC t n1 n2 | 3-76 |
| ESC r c1 c2 d1 ... dk | 3-77 |
| ESC u n | 3-79 |
| ESC x n | 3-80 |
| ESC w n | 3-81 |
| 3-3-16) Others | 3-82 |
| RS | 3-82 |
| CAN | 3-82 |
| ESC U n | 3-84 |
| ESC GS # m N n1 n2 n3 n4 LF NUL | 3-85 |
| ESC # @ LF NUL | 3-86 |
| ESC # N ? n1 n2 n3 n4 LF NUL | 3-86 |

| | | |
|----|--|------|
| 4. | CHARACTER CODE TABLES | 4-1 |
| 5. | APPENDIX | 5-1 |
| | 5-1) Appendix 1: Bar Code Specification Details <Thermal> | 5-1 |
| | 5-1-1) Code 39 | 5-1 |
| | 5-1-2) Interleaved 2 of 5 | 5-1 |
| | 5-1-3) JAN/EAN/UPC | 5-2 |
| | 5-1-4) Code 128 | 5-3 |
| | 5-1-5) Code 93 | 5-5 |
| | 5-1-6) NW7 (CODERBAR) | 5-5 |
| | 5-2) Appendix 2 – Status Specifications <Shared> | 5-6 |
| | 5-2-1) ENQ Command Status | 5-6 |
| | 5-2-2) EOT Command Status | 5-6 |
| | 5-2-3) Automatic Status | 5-7 |
| | 5-2-4) Printer Status Transmission Specification when using Ethernet and Wireless LAN Interfaces | 5-12 |
| | 5-3) Appendix 3 – Blank Code Page Configuration <Thermal> | 5-14 |
| | 5-4) Appendix 4: QR Code Maximum Input Character Count in Each Version <Thermal> | 5-16 |
| 6. | SPECIAL APPENDIX COMMAND LIST BY MODEL | 6-1 |
| 7. | SPECIAL APPENDIX COMMAND FUNCTION LIST | 7-1 |
| | 7-1) HSP7000 | 7-1 |
| | 7-1-1) Setting Command List | 7-1 |
| | 7-1-2) Execution Command List | 7-6 |

1. GENERAL DESCRIPTION

This specifications document describes the command specifications for the STAR MODE on hybrid printers. Information contained herein applies to models with the following conditions.

- Hybrid printers
- Interfaces:
 - Parallel
- RS-232C
- USB
- Ethernet

< Applicable Models:>

- HSP7000

2. COMMAND FUNCTION LIST

• Standard Commands

| Class | Commands | Name | |
|------------------------------|----------|---|---|
| | | Thermal | Slip, Validation |
| Font style and character set | ESC RS F | Select font | - |
| | ESC GS t | Select code page | ← |
| | ESC GS = | Write blank code page data | ← |
| | ESC R | Specify international character set | ← |
| | ESC / | Specify/cancel slash zero | ← |
| | ESC SP | Set ANK right space | ← |
| | ESC M | Specify 12 dot pitch | Specify 7 x 9 font (half dots) |
| | ESC P | Specify 15 dot pitch | Specify 5 x 9 font (2P-1) |
| | ESC : | Specify 16 dot pitch | Specify 5 x 9 font (3P-1) |
| | ESC g | Specify 14 dot pitch | - |
| | ESC 6 | - | - |
| Character expansion settings | ESC i | Set/cancel the double wide/high | - |
| | ESC W | Specify/cancel expanded wide | ← |
| | ESC h | Specify/cancel expanded high | ← |
| | SO | Set double wide printing | ← |
| | DC4 | Cancel expanded wide | ← |
| | ESC SO | Set double high | - |
| | ESC DC4 | Cancel expanded high | - |
| Print modes | ESC E | Select emphasized printing | ← |
| | ESC F | Cancel emphasized printing | ← |
| | ESC - | Select/cancel underline mode | ← |
| | ESC _ | Select/cancel upperline mode | ← |
| | ESC 4 | Selects white/black inversion | Select white/black inversion red/black colors (substitute function) |
| | ESC 5 | Cancel white/black inversion | Cancel white/black inversion red/black colors (substitute function) |
| | ESC GS 4 | - | Select red/black substitute function [ESC 4/5 setting] |
| | SI | Select upside-down printing | ← |
| | DC2 | Cancel upside-down printing | ← |
| | ESC RS i | - | Specify/cancel character rotated mode |
| Line spacing | LF | Line feed | ← |
| | CR | Line feed | ← |
| | ESC a | Feed paper n lines | ← |
| | ESC z | Select line feed amount | ← |
| | ESC 0 | Specify line feed to 3 mm | Specify line feed amount of 1/8 inch |
| | ESC 1 | Specify line feed to 3 mm | Specify line feed amount of 7/72 inch |
| | ESC J | n/4 mm line feed | n/72 inch paper feed |
| | ESC j | - | Reverse paper feed |
| | ESC I | n/8mm line feed | n/144 inch paper feed |
| | ESC A | Specify line feed amount of 3 mm/4mm | Define n/72 inch pitch line feed |
| | ESC 2 | Specify line feed amount (Defined by ESC A n) | ← |
| | ESC 3 | - | Specify n/216 inch paper feed |
| | ESC y | - | Specify n/144 inch paper feed |

| Class | Commands | Name | |
|-------------------------------|---------------|---|-------------------------------------|
| | | Thermal | Slip, Validation |
| Page control | FF | Form feed | - |
| | ESC C | Set page length to n lines | - |
| | ESC C 0 | Set page length in n x 24 mm units | - |
| Horizontal direction position | VT | Feed paper to vertical tab position | - |
| | ESC B | Set vertical tab position | - |
| | ESC I | Set left margin | ← |
| | ESC Q | Set right margin | ← |
| | HT | Move horizontal tab | ← |
| | ESC D | Set/cancel horizontal tab | ← |
| | ESC GS A | Move absolute position | ← |
| | ESC GS R | Move relative position | ← |
| | ESC GS a | Specify position alignment | ← |
| | Download | ESC & | Register/delete download characters |
| ESC % | | Set/cancel download characters | ← |
| ESC K | | Standard density bit image | ← |
| Bit image Graphics | ESC L | High density bit image | ← |
| | ESC k | Fine bit image | - |
| | ESC X | Fine bit image | - |
| | ESC ^ | - | 9 Dot bit image |
| | ESC FS q | Register logo | ← |
| Logos | ESC FS p | Print logo | ← |
| | ESC RS L | Logo batch control | ← |
| | ESC b | Print bar code | - |
| Bar Codes | ESC d | Auto-cutter | - |
| Cutter control | ESC BEL | Set external drive device 1 pulse width | ← |
| | BEL | External device 1 drive instruction | ← |
| | FS | External device 1 drive instruction | ← |
| | SUB | External device 2 drive instruction | ← |
| | EM | External device 2 drive instruction | ← |
| | ESC GS BEL | Ring buzzer | - |
| | ESC GS EM DC1 | Set external buzzer drive pulse condition | ← |
| | ESC GS EM DC2 | Execute external buzzer drive | ← |
| Print Setting | ESC RS d | Set print density | - |
| | ESC RS r | Set printing speed | - |
| Status | ESC RS a | Set status transmission conditions | ← |
| | ESC ACK SOH | Real-time printer status (ASB Status) | ← |
| | ENQ | Real-time printer status (1) | ← |
| | EOT | Real-time printer status (2) | ← |
| | ETB | Update of ETB status | ← |
| | ESC RS E | Clear ETB counter, initialize ETB status | ← |

| Class | Commands | Name | |
|-----------------|-----------|--|--|
| | | Thermal | Slip, Validation |
| Kanji Character | ESC p | Set JIS Kanji Character mode | ← |
| | ESC q | Cancel JIS Kanji Character mode | ← |
| | ESC \$ | Set/cancel JIS Kanji Character mode | ← |
| | ESC s | Set two-byte Kanji characters left/right spaces | ← |
| | ESC t | Set single-byte Kanji characters left/right spaces | ← |
| | ESC r | Register Chinese download characters | ← |
| | ESC u | - | Specify two-byte 16 x 16 dot Kanji Character (Single density/double density) |
| | ESC x | - | Specify expanded Kanji characters (Double tall/double high & wide) |
| | ESC w | - | Specify expanded Kanji characters (batch double tall/double high & wide) |
| Others | RS | - | Ring buzzer |
| | CAN | Cancel print data and initialize commands | ← |
| | ESC @ | Initialize commands | ← |
| | ESC U | - | Select printing direction |
| | ESC GS # | Set memory switch | ← |
| | ESC # @ | Initialize all memory switches | ← |
| | ESC # N ? | Inquire memory switch setting contents | ← |
| | ESC # * | Inquire printer version | ← |
| | ESC ? | Reset printer | ← |
| | DC3 | Printer deselect | ← |
| | DC1 | Select printer | ← |

(*) Kanji character commands

- Kanji character control commands are ignored on printers not installed with Kanji character fonts (those intended for overseas).
- All Kanji control commands are ignored if the specification for the location of use is specified as SBCS (single byte countries) by the memory switch.

• Raster Related Commands

| Class | Commands | Name | |
|-----------------|-------------------------------|---|------------------|
| | | Thermal | Slip, Validation |
| Raster commands | ESC * r R | Initialize raster mode | - |
| | ESC * r A | Enter raster mode | - |
| | ESC * r B | Quit raster mode | - |
| | ESC * r C | Clear raster data | - |
| | ESC * r D | Drawer drive | - |
| | ESC * r E | Set raster EOT mode | - |
| | ESC * r F | Set raster FF mode | - |
| | ESC * r P | Set raster page length | - |
| | ESC * r Q | Set raster print quality | - |
| | ESC * r m l | Set raster left margin | - |
| | ESC * r m r | Set raster right margin | - |
| | ESC * r T | Set raster top margin | - |
| | ESC * r K | Set raster print color | - |
| | b n1 n2 d1 ... dk | Transfer raster data (auto line feed) | - |
| | k n1 n2 d1 ... dk | Transfer raster data | - |
| | ESC * r Y | Move vertical direction position (Line feed for specified dots) | - |
| | ESC FF NUL | Execute form feed mode | - |
| | ESC FF EOT | Execute EOT mode | - |
| | ESC * r N | Discard specified byte count of data | - |
| ESC * r V | Execute external buzzer drive | - | |

• Black Mark Related Commands

| Class | Commands | Name | |
|-----------------------------|----------|-------------------------------------|------------------|
| | | Thermal | Slip, Validation |
| Black mark Related commands | ESC d | Auto-cutter: | - |
| | FF | Execute top of form | - |
| | ESC C | Set page length to n lines | - |
| | ESC C 0 | Set page length in n x 24 mm units | - |
| | VT | Feed paper to vertical tab position | - |
| | ESC B | Set vertical tab position | - |

• 2-Color Printing Related Commands

| Class | Commands | Name | |
|-----------------------------------|----------|--|---|
| | | Thermal | Slip, Validation |
| 2-Color Printing Related commands | ESC RS c | Specify printing color in 2 color printing mode | - |
| | ESC RS C | Select/cancel 2-color printing mode | - |
| | ESC 4 | Specify white/black inversion or printing color red | Select white/black inversion red/black colors (substitute function) |
| | ESC 5 | Cancel white/black inversion or specify printing color black | Cancel white/black inversion red/black colors (substitute function) |
| | ESC RS d | Set print density | - |
| | ESC RS r | Set printing speed | - |
| | ESC FS q | Register logo | ← |
| | ESC FS p | Print logo | ← |

• Mark Commands

| Class | Commands | Name | |
|---------------|------------|--|------------------|
| | | Thermal | Slip, Validation |
| Mark Commands | ESC GS * 0 | Print mark | - |
| | ESC GS * 1 | Specify mark height and line feed | - |
| | ESC GS * 2 | At each mark number Specify mark color, mark horizontal width | - |
| | ESC GS * W | Register mark format to non-volatile memory | - |
| | ESC GS * C | Initialize mark format from non-volatile memory | - |

• Auto Logo Commands

| Class | Commands | Name | |
|--------------------|------------|---|------------------|
| | | Thermal | Slip, Validation |
| Auto Logo Commands | ESC GS / W | Register Auto Logo setting to non-volatile memory | - |
| | ESC GS / C | Initialize Auto Logo setting from non-volatile memory | - |
| | ESC GS / 1 | Set ON/OFF for Auto Logo function | - |
| | ESC GS / 2 | Set command characters | - |
| | ESC GS / 3 | Set user macro 1 | - |
| | ESC GS / 4 | Set user macro 2 | - |
| | ESC GS / 5 | Set command character switching method | - |
| | ESC GS / 6 | Set partial cut just prior to Auto Logo printing | - |

• PDF417 Commands

| Class | Commands | Name | |
|-----------------|--------------|---|------------------|
| | | Thermal | Slip, Validation |
| PDF417 Commands | ESC GS x S 0 | Set PDF417 bar code size | - |
| | ESC GS x S 1 | Set PDF417 ECC (security level) | - |
| | ESC GS x S 2 | Set PDF417 module x direction size | - |
| | ESC GS x S 3 | Set PDF417 module aspect ratio | - |
| | ESC GS x D | Set PDF417 bar code data | - |
| | ESC GS x P | Print PDF417 bar code | - |
| | ESC GS x I | Get PDF417 bar code expansion information | ← |

• Print Start Trigger Control Commands

| Class | Commands | Name | |
|------------------------|------------|------------------------|------------------|
| | | Thermal | Slip, Validation |
| Print starting trigger | ESC GS g 0 | Print starting trigger | - |
| | ESC GS g 1 | Set print start timer | - |

• QR Code Commands

| Class | Commands | Name | |
|---------|--------------|--------------------------------------|------------------|
| | | Thermal | Slip, Validation |
| QR Code | ESC GS y S 0 | Set QR code model | - |
| | ESC GS y S 1 | Set QR code mistake correction level | - |
| | ESC GS y S 2 | Set QR code cell size | - |
| | ESC GS y D 1 | Set QR code data (auto setting) | - |
| | ESC GS y D 2 | Set QR code data (manual setting) | - |
| | ESC GS y P | Print QR code | - |
| | ESC GS y I | Get QR code expansion information | ← |

• Page Function Commands

| Class | Commands | Name | |
|---------------|------------|-------------------------|------------------|
| | | Thermal | Slip, Validation |
| Page Function | ESC GS h 0 | 180° inversion function | - |
| | ESC GS h 1 | Water mark function | - |

• Slip/Validation Function Commands

| Class | Commands | Name | |
|---------------|----------|---------|-------------------------------------|
| | | Thermal | Slip, Validation |
| Slip Function | ESC SI | - | - |
| | ESC FF | - | Slip/Validation Function |
| | ESC VT | - | - |
| | ESC EM | - | Set slip/validation automatic clamp |
| | ESC US | - | - |

• Page Mode Commands

| Class | Commands | Name | |
|-----------|----------|---------|--------------------------------|
| | | Thermal | Slip, Validation |
| Page mode | FF | - | Batch print page data |
| | ESC n | - | Select page mode |
| | ESC ! | - | Select line mode |
| | ESC * | - | Set page mode print region |
| | ESC T | - | Sets page mode print direction |

• Station Selection Command

| Class | Commands | Name | |
|-------------------|----------|-------------------|------------------|
| | | Thermal | Slip, Validation |
| Station Selection | ESC + A | Station Selection | ← |

• Presenter Related Commands

| Class | Commands | Name | |
|----------------------------|-----------|---------|------------------|
| | | Thermal | Slip, Validation |
| Presenter Related commands | ESC SYN 0 | - | - |
| | ESC SYN 1 | - | - |
| | ESC SYN 3 | - | - |
| | ESC SYN 4 | - | - |

• MICR Related Command

| Class | Commands | Name | |
|-------|----------|---------------|------------------|
| | | Thermal | Slip, Validation |
| MICR | ESC FS M | MICR function | ← |

3. COMMAND DETAILS

3-1) Explanation of Terms

- Reception buffer

The buffer for storing data (reception data) received from the host, as it is called the reception buffer. Reception data is temporarily stored in the reception buffer, then processed sequentially.

- Line buffer

The buffer for storing image data for printing is called the line buffer.

- Line buffer full

The state in which the buffer has no more space available is called line buffer full. When the buffer is full in line mode, data in the line buffer is printed and a line feed is performed when new print data is processed. This is the same as a Line Feed. When the line buffer is full in the page mode, the printer move the print position to the head of the next line then starts with the new print data.

- Top of line

The top of line is a state that satisfies the following conditions.

- A. There is currently no print data in the line buffer.
- B. The position is not specified with the horizontal direction position command.

- Printable region

This is the maximum printable area with the printer's specifications.

- Print region

This is the printing area specified by a command.(Print region \leq printable region)

- Print data expansion position

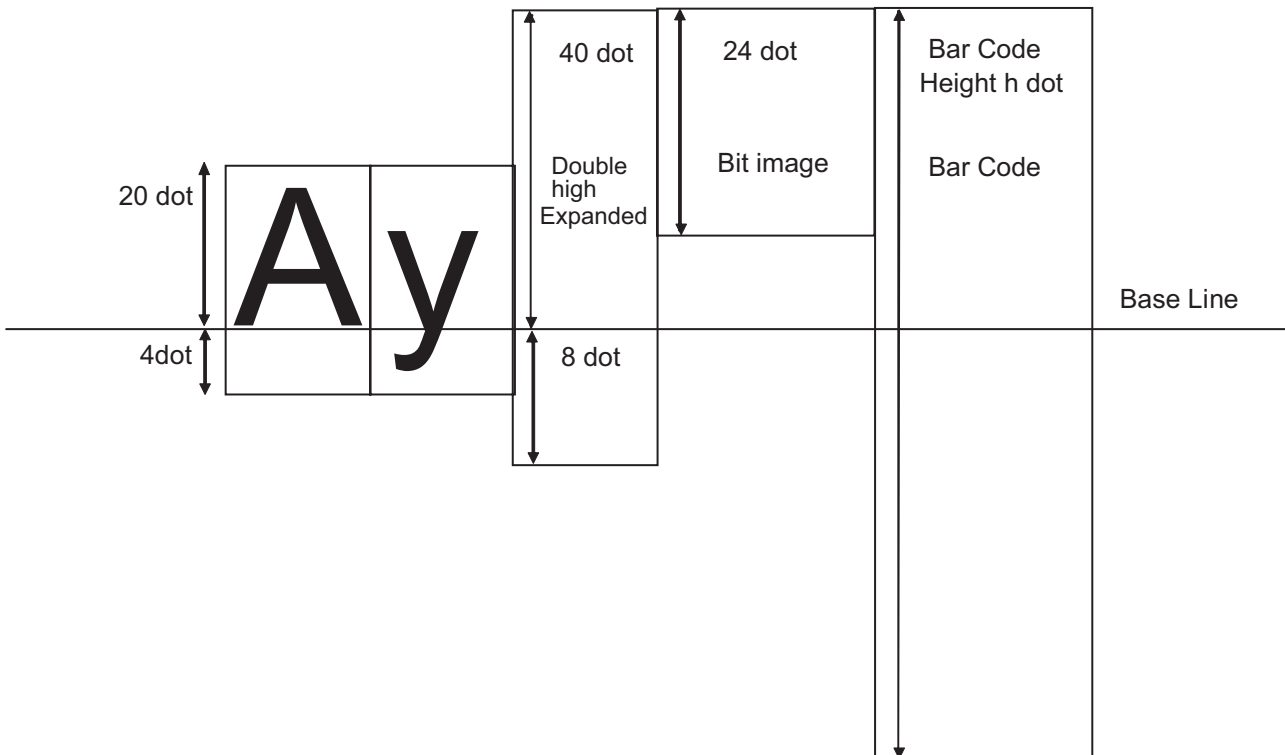

3-2) Exception processing

1) Undefined codes

Codes from <00>H to <1F>H are targeted. When codes not defined as commands in this region are received, they are discarded.

(Ex.) If processing the data string of <30>H<31>H<03>H<32>H<0A>H<33>H, the printer will discard <03>H as an undefined code.

2) Undefined commands

When data continuing the codes of ESC, FS, GS, DLE are codes not defined as commands, ESC, FS,GS and subsequent codes are discarded.

(Ex.) If processing the data string of <30>H<1B>H<22>H<31>H<32>H, the printer will read and discard <1B>H<22>H as an undefined command.

3) Settings outside of the defined area

Processing values outside of the defined area in commands accompanying arguments, those commands are ignored and the preset values are unchanged.

(Ex.:) If processing the data string of <1B>H<52>H<15>H, the printer will discard the data string of <1B>H<52>H<15>H because although <1B>H<52>H is defined as a commands (ESC R) , the argument <15>H is outside of the definition. Therefore, the international character set that is already set experiences no change.

3-3) Standard Command Details
3-3-1) Font style and character set

ESC RS F n

| | | | | | |
|-----------------|-------------|-----|-------------------|----|---|
| [Name] | Select font | | | | |
| [Code] | ASCII | ESC | RS | F | n |
| | Hexadecimal | 1B | 1E | 46 | n |
| | Decimal | 27 | 30 | 70 | n |
| [Defined Area] | Thermal | : | 0 ≤ n ≤ 1, n = 16 | | |
| | Slip | : | - | | |
| | Validation | : | - | | |
| [Initial Value] | Thermal | : | n = 0 | | |
| | Slip | : | - | | |
| | Validation | : | - | | |

[Function]
 <Thermal>

Select font

| n | Font |
|----|-----------------------|
| 0 | Font-A (12 x 24 dots) |
| 1 | Font-B (9 x 24 dots) |
| 16 | OCR-B (16 x 24 dots) |

When OCR-B font is selected, the following functions are invalid.

- Code Pages
- Blank Code Pages
- International Characters
- Slashed Zero

When using the OCR-B font to read characters using a scanner, cancel adornment, expansion and external character settings. Also, check the OCR-B font by actual use.

<Slip>, <Validation>

Only setting is valid
 Setting is valid after switching to thermal.

ESC GS t n

[Name] Select code page

| | | | | | |
|--------|-------------|-----|----|-----|---|
| [Code] | ASCII | ESC | GS | t | n |
| | Hexadecimal | 1B | 1D | 74 | n |
| | Decimal | 27 | 29 | 116 | n |

[Defined Area] Thermal : $0 \leq n \leq 21, 32 \leq n \leq 34, 64 \leq n \leq 79, n = 255$

Slip : $0 \leq n \leq 21, 32 \leq n \leq 34, 64 \leq n \leq 79, n = 255$

Validation : $0 \leq n \leq 21, 32 \leq n \leq 34, 64 \leq n \leq 79, n = 255$

[Initial Value] Thermal : Memory switch setting, when set to DBCS, Japanese characters normal katakana are fixed.

Slip : Memory switch setting, when set to DBCS, Japanese characters normal katakana are fixed.

Validation : Memory switch setting, when set to DBCS, Japanese characters normal katakana are fixed.

[Function] Specifies code page
When installed with Japanese language characters and DBCS setting, this command is ignored.

| n | Code Page |
|----|-----------------------------------|
| 0 | Normal |
| 1 | CodePage437 (USA,Std. Europe) |
| 2 | Katakana |
| 3 | CodePage437 (USA, Std. Europe) |
| 4 | Codepage 858 (Multilingual) |
| 5 | Codepage 852 (Latin-2) |
| 6 | Codepage 860 (Portuguese) |
| 7 | Codepage 861 (Icelandic) |
| 8 | Codepage 863 (Canadian French) |
| 9 | Codepage 865 (Nordic) |
| 10 | Codepage 866 (Cyrillic Russian) |
| 11 | Codepage 855 (Cyrillic Bulgarian) |
| 12 | Codepage 857 (Turkish) |
| 13 | Codepage 862 (Israel (Hebrew)) |
| 14 | Codepage 864 (Arabic) |
| 15 | Codepage 737 (Greek) |
| 16 | Codepage 851 (Greek) |
| 17 | Codepage 869 (Greek) |
| 18 | Codepage 928 (Greek) |
| 19 | Codepage 772 (Lithuanian) |
| 20 | Codepage 774 (Lithuanian) |
| 21 | Codepage 874 (Thai) |

| n | Code Page |
|-----|-----------------------------------|
| 32 | Code Page 1252 (Windows Latin -1) |
| 33 | Codepage 1250 (Windows Latin-2) |
| 34 | Codepage 1251 (Windows Cyrillic) |
| 64 | Codepage 3840 (IBM-Russian) |
| 65 | Codepage 3841 (Gost) |
| 66 | Codepage 3843 (Polish) |
| 67 | Codepage 3844 (CS2) |
| 68 | Codepage 3845 (Hungarian) |
| 69 | Codepage 3846 (Turkish) |
| 70 | Codepage 3847 (Brazil-ABNT) |
| 71 | Codepage 3848 (Brazil-ABICOMP) |
| 72 | Codepage 1001 (Arabic) |
| 73 | Codepage 2001 (Lithuanian-KBL) |
| 74 | Codepage 3001 (Estonian-1) |
| 75 | Codepage 3002 (Estonian-2) |
| 76 | Codepage 3011 (Latvian-1) |
| 77 | Codepage 3012 (Latvian-2) |
| 78 | Codepage 3021 (Bulgarian) |
| 79 | Codepage 3041 (Maltese) |
| 255 | Empty page |

(Note) The settings using this command are valid for all stations and modes.

ESC GS = n1 n2 da1 da2 ... dak db1 db2 ... dbk

[Name] Write blank code page data

| | | | | | | | | | | | | | | |
|--------|-------------|-----|----|----|----|----|-----|-----|----|-----|-----|-----|----|-----|
| [Code] | ASCII | ESC | GS | = | n1 | n2 | da1 | da2 | .. | dak | db1 | db2 | .. | dbk |
| | Hexadecimal | 1B | 1D | 3D | n1 | n2 | da1 | da2 | .. | dak | db1 | db2 | .. | dbk |
| | Decimal | 27 | 29 | 61 | n1 | n2 | da1 | da2 | .. | dak | db1 | db2 | .. | dbk |

[Defined Area] Thermal : n1 = 0, n2 = 48, 1 ≤ (n1 + n2 x 256)
 0 ≤ da ≤ 255 (Font-A data), db = 0 (Star mode does not have Font-B), k = (n1 + n2 x 256)

Slip : -
 Validation : -

[Initial Value] Thermal : -
 Slip : -
 Validation : -

[Function] A blank code page indicates a character code table where character codes from 80h to FFh are all blank.
 A blank code page can be selected using the ESC GS t n command n = 255.
 The printer is reset when writing with this command is completed.

[Font-A Data Format Vertical 24 dots x Horizontal 12 dots]
 • = Data region/ ○ = Zero data

(Font - A Data Format Vertical 24 dot x Horizontal 12 dot)

| | MSB | | | | LSB | | | | | MSB | | | | LSB | | | |
|------|-----|---|---|---|-----|---|---|---|------|-----|---|---|---|-----|---|---|---|
| Da1 | • | • | • | • | • | • | • | • | Da2 | • | • | • | • | ○ | ○ | ○ | ○ |
| Da3 | • | • | • | • | • | • | • | • | Da4 | • | • | • | • | ○ | ○ | ○ | ○ |
| Da5 | • | • | • | • | • | • | • | • | Da6 | • | • | • | • | ○ | ○ | ○ | ○ |
| Da7 | • | • | • | • | • | • | • | • | Da8 | • | • | • | • | ○ | ○ | ○ | ○ |
| Da9 | • | • | • | • | • | • | • | • | Da10 | • | • | • | • | ○ | ○ | ○ | ○ |
| Da11 | • | • | • | • | • | • | • | • | Da12 | • | • | • | • | ○ | ○ | ○ | ○ |
| Da13 | • | • | • | • | • | • | • | • | Da14 | • | • | • | • | ○ | ○ | ○ | ○ |
| Da15 | • | • | • | • | • | • | • | • | Da16 | • | • | • | • | ○ | ○ | ○ | ○ |
| Da17 | • | • | • | • | • | • | • | • | Da18 | • | • | • | • | ○ | ○ | ○ | ○ |
| Da19 | • | • | • | • | • | • | • | • | Da20 | • | • | • | • | ○ | ○ | ○ | ○ |
| Da21 | • | • | • | • | • | • | • | • | Da22 | • | • | • | • | ○ | ○ | ○ | ○ |
| Da23 | • | • | • | • | • | • | • | • | Da24 | • | • | • | • | ○ | ○ | ○ | ○ |
| Da25 | • | • | • | • | • | • | • | • | Da26 | • | • | • | • | ○ | ○ | ○ | ○ |
| Da27 | • | • | • | • | • | • | • | • | Da28 | • | • | • | • | ○ | ○ | ○ | ○ |
| Da29 | • | • | • | • | • | • | • | • | Da30 | • | • | • | • | ○ | ○ | ○ | ○ |
| Da31 | • | • | • | • | • | • | • | • | Da32 | • | • | • | • | ○ | ○ | ○ | ○ |
| Da33 | • | • | • | • | • | • | • | • | Da34 | • | • | • | • | ○ | ○ | ○ | ○ |
| Da35 | • | • | • | • | • | • | • | • | Da36 | • | • | • | • | ○ | ○ | ○ | ○ |
| Da37 | • | • | • | • | • | • | • | • | Da38 | • | • | • | • | ○ | ○ | ○ | ○ |
| Da39 | • | • | • | • | • | • | • | • | Da40 | • | • | • | • | ○ | ○ | ○ | ○ |
| Da41 | • | • | • | • | • | • | • | • | Da42 | • | • | • | • | ○ | ○ | ○ | ○ |
| Da43 | • | • | • | • | • | • | • | • | Da44 | • | • | • | • | ○ | ○ | ○ | ○ |
| Da45 | • | • | • | • | • | • | • | • | Da46 | • | • | • | • | ○ | ○ | ○ | ○ |
| Da47 | • | • | • | • | • | • | • | • | Da48 | • | • | • | • | ○ | ○ | ○ | ○ |

● = Data Region / ○ = Zero Data

<Slip>, <Validation>

Only registration is possible.
 Registration data is printable after switching to thermal.

ESC R n

[Name] Specify international character set

| | | | | |
|--------|-------------|-----|----|---|
| [Code] | ASCII | ESC | R | n |
| | Hexadecimal | 1B | 52 | n |
| | Decimal | 27 | 82 | n |

[Defined Area] Thermal : $0 \leq n \leq 14$, $n = 64$, $48 \leq N \leq 57$ ("0" $\leq n \leq$ "9"), $65 \leq n \leq 69$ ("A" $\leq n \leq$ "E")

Slip : $0 \leq n \leq 14$, $n = 64$, $48 \leq N \leq 57$ ("0" $\leq n \leq$ "9"), $65 \leq n \leq 69$ ("A" $\leq n \leq$ "E")

Validation : $0 \leq n \leq 14$, $n = 64$, $48 \leq N \leq 57$ ("0" $\leq n \leq$ "9"), $65 \leq n \leq 69$ ("A" $\leq n \leq$ "E")

[Initial Value] Thermal : Memory switch setting

When installed with Japanese language characters and DBCS setting: Fixed at $n = 8$

Slip : Memory switch setting

When installed with Japanese language characters and DBCS setting: Fixed at $n = 8$

Validation : Memory switch setting

When installed with Japanese language characters and DBCS setting: Fixed at $n = 8$

[Function] Specifies international characters
See each printer's product specifications manual for details on the memory switch settings.

| n | International Characters |
|--------|--------------------------|
| 0, 48 | USA |
| 1, 49 | France |
| 2, 50 | Germany |
| 3, 51 | UK |
| 4, 52 | Denmark |
| 5, 53 | Sweden |
| 6, 54 | Italy |
| 7, 55 | Spain |
| 8, 56 | Japan |
| 9, 57 | Norway |
| 10, 65 | Denmark II |
| 11, 66 | Spain II |
| 12, 67 | Latin America |
| 13, 68 | Korea |
| 14, 69 | Ireland |
| 64 | Legal |

When installed with Japanese language characters and DBCS setting, this command is ignored.

Note that if the code page 3041 (Maltese) is selected for the code page, international characters are disabled and the specified characters of code page 3041 are printed.

At that time, the specified international character setting is valid when changed to a different code page.

(Note) The settings using this command are valid for all stations and modes.

ESC / N

[Name] Specify/cancel slash zero

[Code] ASCII ESC / n
 Hexadecimal 1B 2F n
 Decimal 27 47 n

[Defined Area] Thermal : n = 0, 1, 48, 49
 Slip : n = 0, 1, 48, 49
 Validation : n = 0, 1, 48, 49

[Initial Value] Thermal : Memory switch setting
 Slip : Memory switch setting
 Validation : Memory switch setting

[Function] Specifies and cancels slash zeros.
 See each printer's product specifications manual for details on the memory switch settings.

| | |
|-------|--------------------------|
| n | International Characters |
| 0, 48 | Cancels slash zero |
| 1, 49 | Specifies slash zero |

Note that if the code page 3041 (Maltese) is selected for the code page, slash zero is invalid, and normal zeros will be printed.

At that time, the specified slash zero setting is valid when changed to a different code page.

(Note) The settings using this command are valid for all stations and modes.

ESC SP n

[Name] Set ANK right space

[Code] ASCII ESC SP n
 Hexadecimal 1B 20 n
 Decimal 27 32 n

[Defined Area] Thermal : $0 \leq n \leq 15, 48 \leq N \leq 57$ ("0" $\leq n \leq$ "9"), $65 \leq n \leq 70$ ("A" $\leq n \leq$ "F")
 Slip : $0 \leq n \leq 15, 48 \leq N \leq 57$ ("0" $\leq n \leq$ "9"), $65 \leq n \leq 70$ ("A" $\leq n \leq$ "F")
 Validation : $0 \leq n \leq 15, 48 \leq N \leq 57$ ("0" $\leq n \leq$ "9"), $65 \leq n \leq 70$ ("A" $\leq n \leq$ "F")

[Initial Value] Thermal : Memory switch setting
 Slip : n = 0
 Validation : n = 0

[Function]
 <Thermal>

Specifies the right space for ANK 12 x 24 dot fonts in n dots.
 Character spacing can be specified also with the following commands.

- Specify 12 dot pitch (ESC M)
- Specify 14 dot pitch (ESC g)
- Specify 15 dot pitch (ESC P)
- Specify 16 dot pitch (ESC :)

<Slip>, <Validation>

Specifies right space of characters with n half dots.
 When in horizontal double-wide printing, the right space is also double.

(Note) The settings by this command are valid for all stations.

Setting value is shared when thermal and slip, validation line mode is selected.

The setting value when slip, validation page mode is selected is shared only when slip, validation page mode is selected.

ESC M

[Name] (Thermal) Specify 12 dot pitch/(Slip) specify 7 x 9 font (half dots) (default)

| | | | |
|--------|-------------|-----|----|
| [Code] | ASCII | ESC | M |
| | Hexadecimal | 1B | 4D |
| | Decimal | 27 | 77 |

[Defined Area] Thermal : -
 Slip : -
 Validation : -

[Initial Value] Thermal : Memory switch setting
 Slip : -
 Validation : -

[Function]

<Thermal>

Specifies the right space for ANK 12 x 24 dot fonts in 0 dots.

<Slip>, <Validation>

Specifies 7 x 9 (half) dot font.

Sets the number of printable digits in one line to [total half dot count/(10 + character right space amount)].

When page mode is selected, it is fixed at 5 x 9 fonts, and only the setting is valid.

Setting is valid after switching to line mode.

(Note) The settings by this command are valid for all stations.

ESC P

[Name] (Thermal) Specify 15 dot pitch/(Slip) specify 5 x 9 font (2P-1)

| | | | |
|--------|-------------|-----|----|
| [Code] | ASCII | ESC | P |
| | Hexadecimal | 1B | 50 |
| | Decimal | 27 | 80 |

[Defined Area] Thermal : -
 Slip : -
 Validation : -

[Initial Value] Thermal : Memory switch setting
 Slip : -
 Validation : -

[Function]

<Thermal>

Specifies the right space for ANK 12 x 24 dot fonts in 3 dots.

<Slip>, <Validation>

Specifies 5 x 9 (2 pulse = 1) dot fonts.

Sets the number of printable digits in one line to [total half dot count/(12 + character right space amount)].

(Note) The settings by this command are valid for all stations.

ESC :

[Name] (Thermal) Specify 16 dot pitch/(Slip) specify 5 x 9 font (3P-1)

| | | | |
|--------|-------------|-----|----|
| [Code] | ASCII | ESC | : |
| | Hexadecimal | 1B | 3A |
| | Decimal | 27 | 58 |

| | | | |
|----------------|------------|---|---|
| [Defined Area] | Thermal | : | - |
| | Slip | : | - |
| | Validation | : | - |

| | | | |
|-----------------|------------|---|-----------------------|
| [Initial Value] | Thermal | : | Memory switch setting |
| | Slip | : | - |
| | Validation | : | - |

[Function]
<Thermal>

Specifies the right space for ANK 12 x 24 dot fonts in 4 dots.

<Slip>, <Validation>

Specifies 5 x 9 (3 pulse = 1) dot fonts.

Sets the number of printable digits in one line to [total half dot count/(18 + character right space amount)].

(Note) The settings by this command are valid for all stations.

ESC g

[Name] Specify 14 dot pitch

| | | | |
|--------|-------------|-----|-----|
| [Code] | ASCII | ESC | g |
| | Hexadecimal | 1B | 67 |
| | Decimal | 27 | 103 |

| | | | |
|----------------|------------|---|---|
| [Defined Area] | Thermal | : | - |
| | Slip | : | - |
| | Validation | : | - |

| | | | |
|-----------------|------------|---|-----------------------|
| [Initial Value] | Thermal | : | Memory switch setting |
| | Slip | : | - |
| | Validation | : | - |

[Function]
<Thermal>

Specifies rights space for the ANK 12 x 24 dot fonts to 2 dots.

<Slip>, <Validation>

Only setting is valid

Setting is valid after switching to thermal.

ESC 6

[Name] Specify IBM character set #2

| | | | |
|--------|-------------|-----|----|
| [Code] | ASCII | ESC | 6 |
| | Hexadecimal | 1B | 36 |
| | Decimal | 27 | 54 |

[Defined Area] Thermal : -
Slip : -
Validation : -

[Initial Value] Thermal : -
Slip : -
Validation : -

[Function] Two bytes ignored

ESC 7

[Name] Specify IBM character set #1

| | | | |
|--------|-------------|-----|----|
| [Code] | ASCII | ESC | 7 |
| | Hexadecimal | 1B | 37 |
| | Decimal | 27 | 55 |

[Defined Area] Thermal : -
Slip : -
Validation : -

[Initial Value] Thermal : -
Slip : -
Validation : -

[Function] Two bytes ignored

3-3-2) Character Expansion Settings

ESC i n1 n2

[Name] Set/cancel the double wide/high

| | | | | | |
|--------|-------------|-----|-----|----|----|
| [Code] | ASCII | ESC | i | n1 | n2 |
| | Hexadecimal | 1B | 69 | n1 | n2 |
| | Decimal | 27 | 105 | n1 | n2 |

| | | | |
|-----------------|------------|---|--|
| [Defined Area] | Thermal | : | $0 \leq n1 \leq 5, 48 \leq n1 \leq 53$ ("0" \leq n1 \leq "5"), $0 \leq n2 \leq 5, 48 \leq n2 \leq 53$ ("0" \leq n2 \leq "5") |
| | Slip | : | $0 \leq n1 \leq 5, 48 \leq n1 \leq 53$ ("0" \leq n1 \leq "5"), $0 \leq n2 \leq 5, 48 \leq n2 \leq 53$ ("0" \leq n2 \leq "5") |
| | Validation | : | $0 \leq n1 \leq 5, 48 \leq n1 \leq 53$ ("0" \leq n1 \leq "5"), $0 \leq n2 \leq 5, 48 \leq n2 \leq 53$ ("0" \leq n2 \leq "5") |
| [Initial Value] | Thermal | : | n1 = 0 (Double high cancelled), n2 = 0 (Double wide cancelled) |
| | Slip | : | n1 = 0 (Double high cancelled), n2 = 0 (Double wide cancelled) |
| | Validation | : | n1 = 0 (Double high cancelled), n2 = 0 (Double wide cancelled) |

[Function] Specifies/cancels double high/wide for ANK characters and Kanji characters.
This command is ignored if either n1 or n2 is outside of the defined area.

<Thermal>

| n1 | Expanded high |
|-------|------------------------|
| 0, 48 | Cancel expanded high |
| 1, 49 | Specifies 2x expansion |
| 2, 50 | Specifies 3x expansion |
| 3, 51 | Specifies 4x expansion |
| 4, 52 | Specifies 5x expansion |
| 5, 53 | Specifies 6x expansion |

| n2 | Expanded wide |
|-------|-----------------------------|
| 0, 48 | Cancel expanded wide |
| 1, 49 | Specifies 2x wide expansion |
| 2, 50 | Specifies 3x wide expansion |
| 3, 51 | Specifies 4x wide expansion |
| 4, 52 | Specifies 5x wide expansion |
| 5, 53 | Specifies 6x wide expansion |

<Slip>, <Validation>

| n1 | Expanded high |
|--|------------------------|
| 0, 48 | Cancel expanded high |
| $1 \leq n1 \leq 5, 49 \leq n1 \leq 53$ | Specifies 2x expansion |

| n2 | Expanded wide |
|--|-----------------------------|
| 0, 48 | Cancel expanded wide |
| $1 \leq n2 \leq 5, 49 \leq n2 \leq 53$ | Specifies 2x wide expansion |

However, in standard specifications, only the line feed amount is doubled for font configurations of 6 x 12 IBM block graphic characters.

When slip or validation is selected, and more than double is specified, printing is doubled for every setting.

Setting more than triple is valid after switching to thermal.

(Note) The settings using this command are valid for all stations and modes.

ESC W n

[Name] Specify/cancel expanded wide

| | | | | |
|--------|-------------|-----|----|---|
| [Code] | ASCII | ESC | W | n |
| | Hexadecimal | 1B | 57 | n |
| | Decimal | 27 | 87 | n |

[Defined Area] Thermal : $0 \leq n \leq 5, 48 \leq n \leq 53$, ("0" $\leq n \leq$ "5")
 Slip : $0 \leq n \leq 5, 48 \leq n \leq 53$, ("0" $\leq n \leq$ "5")
 Validation : $0 \leq n \leq 5, 48 \leq n \leq 53$, ("0" $\leq n \leq$ "5")

[Initial Value] Thermal : n = 0 (Double wide cancelled)
 Slip : n = 0 (Double wide cancelled)
 Validation : n = 0 (Double wide cancelled)

[Function] Specifies/cancels double wide for ANK characters and Kanji characters.

<Thermal>

| n | Expanded wide |
|-------|-----------------------------|
| 0, 48 | Cancel expanded wide |
| 1, 49 | Specifies 2x wide expansion |
| 2, 50 | Specifies 3x wide expansion |
| 3, 51 | Specifies 4x wide expansion |
| 4, 52 | Specifies 5x wide expansion |
| 5, 53 | Specifies 6x wide expansion |

<Slip>, <Validation>

| n | Function |
|--------------------------------------|---|
| 0, 48 | Cancels double wide expanded printing |
| $1 \leq n \leq 5, 49 \leq n \leq 53$ | Specifies double wide expanded printing |

When slip or validation is selected, and more than double is specified, printing is doubled for every setting.

Setting more than triple is valid after switching to thermal.

(Note) The settings using this command are valid for all stations and modes.

ESC h n

[Name] Specify/cancel expanded high

| | | | | |
|--------|-------------|-----|-----|---|
| [Code] | ASCII | ESC | h | n |
| | Hexadecimal | 1B | 68 | n |
| | Decimal | 27 | 104 | n |

[Defined Area] Thermal : $0 \leq n \leq 5, 48 \leq n \leq 53$, ("0" $\leq n \leq$ "5")
 Slip : $0 \leq n \leq 5, 48 \leq n \leq 53$, ("0" $\leq n \leq$ "5")
 Validation : $0 \leq n \leq 5, 48 \leq n \leq 53$, ("0" $\leq n \leq$ "5")

[Initial Value] Thermal : n = 0 (Double high cancelled)
 Slip : n = 0 (Double high cancelled)
 Validation : n = 0 (Double high cancelled)

[Function] Specifies/cancels double high for ANK characters and Kanji characters.
 When tall expanded characters and normal printing are mixed in the same line, they are aligned at the bottom.

<Thermal>

| n | Expanded high |
|-------|------------------------|
| 0, 48 | Cancel expanded high |
| 1, 49 | Specifies 2x expansion |
| 2, 50 | Specifies 3x expansion |
| 3, 51 | Specifies 4x expansion |
| 4, 52 | Specifies 5x expansion |
| 5, 53 | Specifies 6x expansion |

<Slip>, <Validation>

| n | Function |
|--------------------------------------|--|
| 0, 48 | Cancels printing of vertical double-high character printing. |
| $1 \leq n \leq 5, 49 \leq n \leq 53$ | Specifies 2x expansion printing |

However, in standard specifications, only the line feed amount is doubled for font configurations of 6 x 12 IBM block graphic characters, without expanding characters.

When slip or validation is selected, and more than double is specified, printing is doubled for every setting.

Setting more than triple is valid after switching to thermal.

When page mode is selected, the line feed amount including the expanded double-tall characters is 1x the normal amount.

(Note) The settings using this command are valid for all stations and modes.

SO

[Name] Set double wide
 [Code] ASCII SO
 Hexadecimal 0E
 Decimal 14

[Defined Area] Thermal : -
 Slip : -
 Validation : -

[Initial Value] Thermal : Cancels 2x wide expansion
 Slip : Cancels 2x wide expansion
 Validation : Cancels 2x wide expansion

[Function] Specifies double wide for ANK characters and Kanji characters.
 This command is equivalent to ESC W 1.

(Note) The settings using this command are valid for all stations and modes.

DC4

[Name] Cancel expanded wide
 [Code] ASCII DC4
 Hexadecimal 14
 Decimal 20

[Defined Area] Thermal : -
 Slip : -
 Validation : -

[Initial Value] Thermal : Cancels 2x wide expansion
 Slip : Cancels 2x wide expansion
 Validation : Cancels 2x wide expansion

[Function] Cancels expanded wide if the following commands specify expanded wide.

- Double wide specifying command (SO)
- Set/cancel double wide (ESC W)
- Set/cancel double wide/high (ESC i)

This command is equivalent to ESC W 0.

(Note) The settings using this command are valid for all stations and modes.

ESC SO

[Name] Set double high

| | | | |
|--------|-------------|-----|----|
| [Code] | ASCII | ESC | SO |
| | Hexadecimal | 1B | 0E |
| | Decimal | 27 | 14 |

[Defined Area] Thermal : -
Slip : -
Validation : -

[Initial Value] Thermal : Double high expansion cancelled.
Slip : Double high expansion cancelled.
Validation : Double high expansion cancelled.

[Function] Specifies double high for ANK characters and Kanji characters.
This command is equivalent to ESC h 1.

(Note) The settings using this command are valid for all stations and modes.

ESC DC4

[Name] Cancel expanded high

| | | | |
|--------|-------------|-----|-----|
| [Code] | ASCII | ESC | DC4 |
| | Hexadecimal | 1B | 14 |
| | Decimal | 27 | 20 |

[Defined Area] Thermal : -
Slip : -
Validation : -

[Initial Value] Thermal : Double high expansion cancelled.
Slip : Double high expansion cancelled.
Validation : Double high expansion cancelled.

[Function] Cancels expanded high if the following commands specify expanded high.

- Double high specifying command (ESC SO)
- Set/cancel the double high (ESC h)
- Set/cancel double wide/high (ESC i)

This command is equivalent to ESC h 0.

(Note) The settings using this command are valid for all stations and modes.

3-3-3) Print mode

ESC E

[Name] Select emphasized printing

| | | | |
|--------|-------------|-----|----|
| [Code] | ASCII | ESC | E |
| | Hexadecimal | 1B | 45 |
| | Decimal | 27 | 69 |

| | | | |
|----------------|------------|---|---|
| [Defined Area] | Thermal | : | - |
| | Slip | : | - |
| | Validation | : | - |

| | | | |
|-----------------|------------|---|--------------------------------|
| [Initial Value] | Thermal | : | Emphasized printing cancelled. |
| | Slip | : | Emphasized printing cancelled. |
| | Validation | : | Emphasized printing cancelled. |

[Function]

<Thermal> Specifies emphasized printing for ANK characters.
IBM block ignores emphasized printing.

<Slip>, <Validation>

Specifies emphasized printing for subsequent data.
When in emphasized printing, data is printed in two passes.
This command is valid for ANK and Kanji characters (Kanji).
(* 2-pass Japanese characters are printed with four passes; 4-pass Japanese characters are printed with 8 passes.)
When page mode is selected, the emphasized printing specification is in page units.

(Note) The settings using this command are valid for all stations and modes.

ESC F

[Name] Cancel emphasized printing

| | | | |
|--------|-------------|-----|----|
| [Code] | ASCII | ESC | F |
| | Hexadecimal | 1B | 46 |
| | Decimal | 27 | 70 |

| | | | |
|----------------|------------|---|---|
| [Defined Area] | Thermal | : | - |
| | Slip | : | - |
| | Validation | : | - |

| | | | |
|-----------------|------------|---|--------------------------------|
| [Initial Value] | Thermal | : | Emphasized printing cancelled. |
| | Slip | : | Emphasized printing cancelled. |
| | Validation | : | Emphasized printing cancelled. |

[Function]

<Thermal>

 Cancels emphasized printing for ANK characters.

<Slip>, <Validation>

 Cancels emphasized printing for subsequent data.

 When page mode is selected, the emphasized printing cancel specification is in page units.

(Note) The settings using this command are valid for all stations and modes.

ESC – n

[Name] Specify/cancel underling mode

[Code] ASCII ESC - n
 Hexadecimal 1B 2D n
 Decimal 27 45 n

[Defined Area] Thermal : n = 0, 1, 48, 49
 Slip : n = 0, 1, 48, 49
 Validation : n = 0, 1, 48, 49

[Initial Value] Thermal : n = 0 (Underline cancelled)
 Slip : n = 0 (Underline cancelled)
 Validation : n = 0 (Underline cancelled)

[Function] Specifies/cancels underline according to n value.

| n | Underline |
|-------|---------------------|
| 0, 48 | Cancels underline |
| 1, 49 | Specifies underline |

Underlines are not applied to horizontal tabs and to specified horizontal direction positions. This command is valid for ANK characters and Japanese characters and is invalid for IBM blocks. Underlines are valid for white/black inversion.

<Thermal>

Underlines are composed of 2 dot lines. When character expansion is specified, underlines are also expanded (when in double-high expansion, underlines are composed of four dots.)

<Slip>, <Validation>

Underlines are applied to the 9th dot of the character. When double-wide expanded characters have been specified, the underline is also expanded, but if double-tall expanded characters have been selected, the underline does not expand in the vertical direction. It remains a one-dot line.

(Note) The settings using this command are valid for all stations and modes.

ESC _ n

[Name] Specify/cancel upperline

| | | | | |
|--------|-------------|-----|----|---|
| [Code] | ASCII | ESC | _ | n |
| | Hexadecimal | 1B | 5F | n |
| | Decimal | 27 | 95 | n |

[Defined Area] Thermal : n = 0, 1, 48, 49
 Slip : n = 0, 1, 48, 49
 Validation : n = 0, 1, 48, 49

[Initial Value] Thermal : n = 0 (Upperline cancelled)
 Slip : n = 0 (Upperline cancelled)
 Validation : n = 0 (Upperline cancelled)

[Function] Specifies/cancels upperline according to n value.

| n | Upperline |
|-------|---------------------|
| 0, 48 | Cancels upperline |
| 1, 49 | Specifies upperline |

Upperlines are not applied to horizontal tabs and to specified horizontal direction positions. This command is valid for ANK characters and Japanese characters and is invalid for IBM blocks. Upperlines are valid for white/black inversion.

<Thermal>

Upperlines are composed of 2 dot lines. When character expansion is specified, upperlines are also expanded (when in double-high expansion, upperlines are composed of four dots.)

<Slip>, <Validation>

Upperlines are applied to the 1st dot of the character. When double-wide expanded characters have been specified, the upperline is also expanded, but if double-tall expanded characters have been selected, the upperline does not expand in the vertical direction. It remains a one-dot line.

(Note) The settings using this command are valid for all stations and modes.

ESC 4

[Name] (Thermal) Specify black/white inversion/(Slip) specify black/white inversion, red/black color (substitute function)

| | | | |
|--------|-------------|-----|----|
| [Code] | ASCII | ESC | 4 |
| | Hexadecimal | 1B | 34 |
| | Decimal | 27 | 52 |

[Defined Area] Thermal : -
Slip : -
Validation : -

[Initial Value] Thermal : White/black inversion cancelled
Slip : White/black inversion cancelled/black color printing specified
Validation : White/black inversion cancelled/black color printing specified

[Function]
<Thermal>

Specifies white/black inversion for ANK characters and Kanji characters.
IBM block ignores white/black inversion.

<Slip>, <Validation>

This command function is based on the selection of red/black substitute function.
The red/black substitute function is selected by the memory switch or the command ESC GS 4 m n.
For details on selecting the red/black substitute function using a command, see the explanation of ESC GS 4 below, and for details on selecting the red/black substitute function using the memory switch, see the printer specifications manual.

(Note) The settings using this command are valid for all stations and modes.

ESC 5

[Name] (Thermal) Cancel black/white inversion/(Slip) cancel black/white inversion, red/black color (substitute function)

| | | | |
|--------|-------------|-----|----|
| [Code] | ASCII | ESC | 5 |
| | Hexadecimal | 1B | 35 |
| | Decimal | 27 | 53 |

[Defined Area] Thermal : -
Slip : -
Validation : -

[Initial Value] Thermal : White/black inversion cancelled
Slip : White/black inversion cancelled/black color printing specified
Validation : White/black inversion cancelled/black color printing specified

[Function]
<Thermal>

Cancels white/black inversion for ANK characters and Kanji characters.

<Slip>, <Validation>

This command function is based on the selection of red/black substitute function.
The red/black substitute function is selected by the memory switch or the command ESC GS 4 m n.
For details on selecting the red/black substitute function using a command, see the explanation of ESC GS 4 below, and for details on selecting the red/black substitute function using the memory switch, see the printer specifications manual.

(Note) The settings using this command are valid for all stations and modes.

ESC GS 4 m n

[Name] Select red/black substitute function [ESC 4/5 setting]

| | | | | | | |
|--------|-------------|-----|----|----|---|---|
| [Code] | ASCII | ESC | GS | 4 | m | n |
| | Hexadecimal | 1B | 1D | 34 | m | n |
| | Decimal | 27 | 29 | 52 | m | n |

| | | | | |
|-----------------|------------|---|-----------------------|------------------|
| [Defined Area] | Thermal | : | - | |
| | Slip | : | m = 1, 2, 49, 50 | |
| | | | When m = 1, 49 ("1") | :n = 0 to 3, 255 |
| | | | When m = 2, 50 ("2") | :n = 0, 2 to 5 |
| | | | When m = 83 ("S") | :n = 0, 1 |
| | Validation | : | m = 1, 2, 49, 50 | |
| | | | When m = 1, 49 ("1") | :n = 0 to 3, 255 |
| | | | When m = 2, 50 ("2") | :n = 0, 2 to 5 |
| | | | When m = 83 ("S") | :n = 0, 1 |
| [Initial Value] | Thermal | : | - | |
| | Slip | : | Memory switch setting | |
| | Validation | : | Memory switch setting | |

[Function]
<Thermal>

Only setting is valid
Setting is valid after switching to slip or validation.

<Slip>, <Validation>

Selects red/black substitute function
Selects characters targeted for adornment with m = 1 (ANK) or m = 2 (Japanese characters), and selects the ESC 4/ESC 5 command functions with n.
Sets the handling of adornment to space characters (ASCII 20Hex) with m = 83.
This command is enabled only when in a state where adornment is cancelled by ESC 4 (when ESC 5 was specified).

• When m = 1, 48 Targeted characters = ANK

| m | n | ESC 4/ESC 5 command functions (ANK) |
|-------|-----|---|
| 1, 49 | 0 | White/black inverted printing (1 Pass) |
| 1, 49 | 1 | <Option 1> White/black inversion (5 x 9 font print) + enhancing (2 passes) |
| 1, 49 | 2 | <Option 2> Upper line + Underline + enhancing (2 passes) |
| 1, 49 | 3 | <Option 3> Upper line + Underline + double tall expanded + enhancing (4 passes) |
| 1, 49 | 255 | No adornment |

• When m = 2, 50 Targeted characters = Japanese Characters

| m | n | ESC 4/ESC 5 command functions (Japanese characters) |
|-------|---|---|
| 2, 50 | 0 | No adornment |
| 2, 50 | 2 | <Option 2> Upper line + Underline + enhancing (4 passes) |
| 2, 50 | 3 | <Option 3> Upper line + Underline + double tall expanded + enhancing (4 passes) |
| 2, 50 | 4 | <Option 4> White/Black Inverted + Double-Tall (2 passes) |
| 2, 50 | 5 | <Option 5> White/Black Inverted + 4 X Expanded (2 passes) |

When using ESC 5 to cancel adornments, it returns to the previously set adornments. (Adornments such as underline, upper line, double-tall expanded and enhancing are cancelled if there is no command to set them (for example the ESC - -1 specification for underlines).

Precautions for selecting <Option 1>

1. Prints white/black inverted characters using 5 x 9 fonts regardless of the current font size setting.
2. Inserts a one dot string of black printing to the head of the white/black inverted characters.
3. Printing data created on a conventional red/black printer, using 1 and 2 above, there are cases in which the printing position will shift to the right and a line of printable characters reduced.
4. Download registered characters defined with 5 x 9 fonts are printed regardless of the current font setting (7 x 9/5 x 9).
5. Must not set "ANK default dot count = Narrow" with the memory switch. (This will cause a white line to appear between characters.)

Precautions for selecting <Option 2> and <Option 3>

1. Do not apply an upper line or an underline when rotating 90 or 270 degrees.

• When m = 83 Red/black adornment of ANK space characters (20H).

| m | n | Red adornment of ANK space characters (20H). |
|----|---|--|
| 83 | 0 | Adorn |
| 83 | 1 | Do not adorn |

This parameter specifies whether to adorn red/black for ANK space characters in red printing mode (black/white inverted).

The ANK space characters are limited to ASCII code 20H in this setting.

In the character code table, if 7FHex is a space character, 7FHex is a target for this setting.

The following is an example of each setting.

It is possible to avoid unnecessary adornment in printing patterns that provide spacing of printing positions with ANK space characters (20H) when red is specified.

(Print Example)

Print Data: <ESC> "4" "TOTAL" 20H 20H 20H 20H 20H 20H 20H 20H "\$1234" <LF>

<Condition 1> ANK adornment = "black/white inverted printing," ANK space characters = "red/black adornment"

TOTAL \$1234

<Condition 2> ANK adornment = "black/white inverted printing," ANK space characters = "no red/black adornment"

TOTAL \$1234

SI

[Name] Select upside-down printing
 [Code] ASCII SI
 Hexadecimal 0F
 Decimal 15

[Defined Area] Thermal : -
 Slip : -
 Validation : -

[Initial Value] Thermal : Upside-down printing cancelled
 Slip : Upside-down printing cancelled
 Validation : Upside-down printing cancelled

[Function] Specifies upside-down printing
 This command is enabled only when at the top of the line.
 Upside down and right-side up characters cannot both exist in the same line.

This command is enabled for following.

- ANK characters
- Kanji characters
- Bit images
- Logos
- Bar codes

<Slip>, <Validation>

When page mode is selected, only setting is valid
 Setting is valid after switching to line mode.

(Note) The settings by this command are valid for all stations.

DC2

[Name] Cancel upside-down printing
 [Code] ASCII DC2
 Hexadecimal 12
 Decimal 18

[Defined Area] Thermal : -
 Slip : -
 Validation : -

[Initial Value] Thermal : Upside-down printing cancelled
 Slip : Upside-down printing cancelled
 Validation : Upside-down printing cancelled

[Function] Cancels upside-down printing
 This command is enabled only when at the top of the line.

(Note) The settings by this command are valid for all stations.

ESC RS i n

[Name] Specify/cancel character rotated mode

| | | | | | |
|--------|-------------|-----|----|-----|---|
| [Code] | ASCII | ESC | RS | i | n |
| | Hexadecimal | 1B | 1E | 69 | n |
| | Decimal | 27 | 30 | 105 | n |

[Defined Area] Thermal : -
 Slip : $0 \leq n \leq 2, 48 \leq n \leq 50$, ("0" $\leq n \leq$ "2")
 Validation : $0 \leq n \leq 2, 48 \leq n \leq 50$, ("0" $\leq n \leq$ "2")

[Initial Value] Thermal : -
 Slip : Character rotation cancelled (n = 0)
 Validation : Character rotation cancelled (n = 0)

[Function]

<Thermal>

Only setting is valid
 Setting is valid after switching to slip or validation.

<Slip>, <Validation>

Specifies direction to rotate print (clockwise) or to cancel rotation for subsequent data, according to the n value.

| n | Set rotation |
|-------|-------------------------|
| 0, 48 | Cancelled (0° rotation) |
| 1, 49 | 270° rotation |
| 2, 50 | 90° rotation |

Rotated characters cannot be applied with underlines or upperlines.

The relationship between double-tall and double-wide is reverse to when cancelled when rotating. When in Kanji character mode, rotation is effective for both ANK characters and Japanese characters.

Kanji character spacing is always applied with the two-byte Kanji character spacing value.

In standard specifications, rotation of IBM block is changed to vertical 8 dot fonts.

The following are precautions for 7 x 9 font character font specification.

- Characters are printed with 5 x 9 fonts (2P=1).
- Download characters registered with 5 x 9 fonts are printed.
- When rotation is cancelled, the characters return to 7 x 9 fonts. (When there is not 5 x 9 specification while rotation is specified.)

When page mode is selected, only setting is valid

Setting is valid after switching to line mode.

3-3-4) Line Spacing

LF

[Name] Line feed
 [Code] ASCII LF
 Hexadecimal 0A
 Decimal 10

[Defined Area] Thermal : -
 Slip : -
 Validation : -

[Initial Value] Thermal : Memory switch setting
 Slip : 1/6 inch line feed
 Validation : 1/6 inch line feed

[Function] Feeds the currently specified amount of paper.
 If print data exists in the line buffer, it prints that data.

<Thermal>
 Initial value of line feed amount is set by the memory switch.

CR

[Name] Carriage return (Print line feed)
 [Code] ASCII CR
 Hexadecimal 0D
 Decimal 13

[Defined Area] Thermal : -
 Slip : -
 Validation : -

[Initial Value] Thermal : Memory switch setting
 Slip : Memory switch setting
 Validation : Memory switch setting

[Function] Specifies the function according to the memory switch value.
 See each printer's product specifications manual for details on the memory switch settings.

<Thermal>

| Memory SW | Function |
|---------------|----------------------|
| Condition (1) | Ignored |
| Condition (2) | Same as the LF code. |

<Slip>, <Validation>

| Memory SW | Function |
|---------------|---|
| Condition (1) | Ignored |
| Condition (2) | Same as the LF code. |
| Condition (3) | Executes only printing, with no paper feed. |

ESC a n

[Name] Feed paper n lines

| | | | | |
|--------|-------------|-----|----|---|
| [Code] | ASCII | ESC | a | n |
| | Hexadecimal | 1B | 61 | n |
| | Decimal | 27 | 97 | n |

| | | | |
|----------------|------------|---|---------------------|
| [Defined Area] | Thermal | : | $1 \leq n \leq 127$ |
| | Slip | : | $1 \leq n \leq 127$ |
| | Validation | : | $1 \leq n \leq 127$ |

| | | | |
|-----------------|------------|---|-----------------------|
| [Initial Value] | Thermal | : | Memory switch setting |
| | Slip | : | 1/6 inch |
| | Validation | : | 1/6 inch |

[Function] Executes paper feed of (currently specified line feed amount x n).
 If print data exists in the line buffer, it prints that data.
 This paper feed amount is unaffected even if there are vertical expanded characters in one line.

ESC z n

[Name] Select line feed amount

[Code] ASCII ESC z n
 Hexadecimal 1B 7A n
 Decimal 27 122 n

[Defined Area] Thermal : n = 1, 49
 Slip : n = 0, 1, n = 48, 49
 Validation : n = 0, 1, n = 48, 49

[Initial Value] Thermal : Memory switch setting
 Slip : 1/6 inch
 Validation : 1/6 inch

[Function]

<Thermal> Specifies the line feed amount.

| n | Amount of Line Feed |
|-------|---------------------------------|
| 1, 49 | Specifies 4 mm line feed amount |

<Slip>, <Validation>

Specifies the line feed amount.

| n | Amount of Line Feed |
|-------|--------------------------------------|
| 0, 48 | Specifies 1/12 inch line feed amount |
| 1, 49 | Specifies 1/6 inch line feed amount |

Line feed amounts can be set independently for both line mode and page mode.

ESC 0

[Name] (Thermal) Specify 3 mm line feed amount/(Slip) specify 1/8 line feed amount

[Code] ASCII ESC 0
 Hexadecimal 1B 30
 Decimal 27 48

[Defined Area] Thermal : -
 Slip : -
 Validation : -

[Initial Value] Thermal : Memory switch setting
 Slip : 1/6 inch
 Validation : 1/6 inch

[Function]

<Thermal> Specifies the line feed amount to 3 mm.

<Slip>, <Validation>

Specifies the line feed amount to 1/8 inch.

Line feed amounts can be set independently for both line mode and page mode.

ESC 1

[Name] (Thermal) Specify 3 mm line feed amount/(Slip) specify 7/72 inch line feed amount

| | | | |
|--------|-------------|-----|----|
| [Code] | ASCII | ESC | 1 |
| | Hexadecimal | 1B | 31 |
| | Decimal | 27 | 49 |

| | | | |
|----------------|------------|---|---|
| [Defined Area] | Thermal | : | - |
| | Slip | : | - |
| | Validation | : | - |

| | | | |
|-----------------|------------|---|-----------------------|
| [Initial Value] | Thermal | : | Memory switch setting |
| | Slip | : | 1/6 inch |
| | Validation | : | 1/6 inch |

[Function]

<Thermal>

Specifies the line feed amount to 3 mm.

<Slip>, <Validation>

Specifies the line feed amount to 7/72 in.

Line feed amounts can be set independently for both line mode and page mode.

ESC J n

[Name] (Thermal) n/4 mm line feed/(Slip) execute n/72 line feed one time

| | | | | |
|--------|-------------|-----|----|---|
| [Code] | ASCII | ESC | J | n |
| | Hexadecimal | 1B | 4A | n |
| | Decimal | 27 | 74 | n |

| | | | |
|----------------|------------|---|---------------------|
| [Defined Area] | Thermal | : | $1 \leq n \leq 255$ |
| | Slip | : | $1 \leq n \leq 255$ |
| | Validation | : | $1 \leq n \leq 255$ |

| | | | |
|-----------------|------------|---|---|
| [Initial Value] | Thermal | : | - |
| | Slip | : | - |
| | Validation | : | - |

[Function]

Execute paper feed.

If print data exists in the line buffer, it prints that data.

This paper feed amount is unaffected even if there are vertical expanded characters in one line.

The single line feed amount setting value is not changed by this command.

<Thermal>

Executes a n/4mm paper feed.

Using this command will intermittently feed paper, therefore, it is normally recommended that this command not be used.

(Currently set line feed amount -n/4 mm) portion is not printed.

<Slip>, <Validation>

Executes a n/72 in paper feed.

ESC j n

[Name] Reverse paper feed

| | | | | |
|--------|-------------|-----|-----|---|
| [Code] | ASCII | ESC | j | n |
| | Hexadecimal | 1B | 6A | n |
| | Decimal | 27 | 106 | n |

[Defined Area] Thermal : -
 Slip : $0 \leq n \leq 255$
 Validation : $0 \leq n \leq 255$

[Initial Value] Thermal : -
 Slip : -
 Validation : -

[Function]
 <Thermal>

Three bytes ignored

<Slip>, <Validation>

Executes a n/72 in reverse direction paper feed.
 If print data exists in the line buffer, it prints that data.
 This paper feed amount is unaffected even if there are vertical expanded characters in one line.
 The single line feed amount setting value is not changed by this command.

ESC I n

[Name] Executes (thermal) n/8 mm line feed/(slip) n/144 line feed one time.

| | | | | |
|--------|-------------|-----|----|---|
| [Code] | ASCII | ESC | I | n |
| | Hexadecimal | 1B | 49 | n |
| | Decimal | 27 | 73 | n |

[Defined Area] Thermal : $1 \leq n \leq 255$
 Slip : $1 \leq n \leq 255$
 Validation : $1 \leq n \leq 255$

[Initial Value] Thermal : -
 Slip : -
 Validation :

[Function]

Executes paper feed.
 If print data exists in the line buffer, it prints that data.
 This paper feed amount is unaffected even if there are vertical expanded characters in one line.
 The single line feed amount setting value is not changed by this command.

<Thermal>

Executes a n/8 mm paper feed.
 Using this command will intermittently feed paper, therefore, it is normally recommended that this command not be used.
 (Currently set line feed amount –n/8mm) portion is not printed.

<Slip>, <Validation>

Executes a n/144 in paper feed.

ESC A n

[Name] Defines (thermal) a 3 mm/4 mm line feed amount/Defines (slip) n/72 inch pitch line feed

| | | | | |
|--------|-------------|-----|----|---|
| [Code] | ASCII | ESC | A | n |
| | Hexadecimal | 1B | 41 | n |
| | Decimal | 27 | 65 | n |

| | | | |
|----------------|------------|---|---------------------|
| [Defined Area] | Thermal | : | $0 \leq n \leq 255$ |
| | Slip | : | $0 \leq n \leq 85$ |
| | Validation | : | $0 \leq n \leq 85$ |

| | | | |
|-----------------|------------|---|---|
| [Initial Value] | Thermal | : | - |
| | Slip | : | - |
| | Validation | : | - |

[Function] Defines the line feed amount.
The line feed amount defined using this command is specified to the current line feed amount by the ESC 2 command.

<Thermal>

| n | Amount of Line Feed |
|-------------------|---------------------------------|
| $0 \leq n \leq 9$ | Defines a 3 mm line feed amount |
| $10 \leq n$ | Defines a 4 mm line feed amount |

<Slip>, <Validation>

Defines line feed amount for one line as n/72 inch.
Line feed amounts can be set independently for both line mode and page mode.

ESC 2

[Name] Specify line feed amount (ESC A n)

| | | | |
|--------|-------------|-----|----|
| [Code] | ASCII | ESC | 2 |
| | Hexadecimal | 1B | 32 |
| | Decimal | 27 | 50 |

| | | | |
|----------------|------------|---|---|
| [Defined Area] | Thermal | : | - |
| | Slip | : | - |
| | Validation | : | - |

| | | | |
|-----------------|------------|---|-----------------------|
| [Initial Value] | Thermal | : | Memory switch setting |
| | Slip | : | 1/6 inch line feed |
| | Validation | : | 1/6 inch line feed |

[Function] Specifies the line feed amount to the value defined by ESC A n.

ESC 3 n

[Name] Specify n/216 inch paper feed

| | | | | |
|--------|-------------|-----|----|---|
| [Code] | ASCII | ESC | 3 | n |
| | Hexadecimal | 1B | 33 | n |
| | Decimal | 27 | 51 | n |

| | | | |
|----------------|------------|---|---------------------|
| [Defined Area] | Thermal | : | - |
| | Slip | : | $0 \leq n \leq 255$ |
| | Validation | : | $0 \leq n \leq 255$ |

| | | | |
|-----------------|------------|---|--------------------|
| [Initial Value] | Thermal | : | - |
| | Slip | : | 1/6 inch line feed |
| | Validation | : | 1/6 inch line feed |

[Function]
<Thermal>

Three bytes ignored

<Slip>, <Validation>

Sets subsequent line feed amounts to a value approximate to n/216 inch.

Because the minimum pitch for the paper feed mechanism is 1/144 of an inch, the setting value will be approximated according to the following equation.

$\text{INT} (n \times 2/3 + 0.5)/144$ of an inch

Line feed amounts can be set independently for both line mode and page mode.

ESC y n

[Name] Specify n/144 inch paper feed

| | | | | |
|--------|-------------|-----|-----|---|
| [Code] | ASCII | ESC | y | n |
| | Hexadecimal | 1B | 79 | n |
| | Decimal | 27 | 121 | n |

| | | | |
|----------------|------------|---|---------------------|
| [Defined Area] | Thermal | : | - |
| | Slip | : | $0 \leq n \leq 255$ |
| | Validation | : | $0 \leq n \leq 255$ |

| | | | |
|-----------------|------------|---|--------------------|
| [Initial Value] | Thermal | : | - |
| | Slip | : | 1/6 inch line feed |
| | Validation | : | 1/6 inch line feed |

[Function]
<Thermal>

Three bytes ignored

<Slip>, <Validation>

Sets subsequent line feed amounts to a n/144 inch.

Line feed amounts can be set independently for both line mode and page mode.

3-3-5) Page Control Commands

FF

| | | |
|--------|-------------|----|
| [Name] | Form feed | |
| [Code] | ASCII | FF |
| | Hexadecimal | 0C |
| | Decimal | 12 |

| | | | |
|-----------------|------------|---|---|
| [Defined Area] | Thermal | : | - |
| | Slip | : | - |
| | Validation | : | - |
| [Initial Value] | Thermal | : | - |
| | Slip | : | - |
| | Validation | : | - |

[Function]
<Thermal>

Executes a form feed.

If the current position is at the top of the page, it form feeds to the top of the next page.

If there is data existing in the line buffer when executing a form feed, it prints that data, then executes the form feed.

However, by printing data remaining in the buffer, and moving to the top of the next page, a form feed is considered to have been executed, so form feed is not performed.

<Slip>, <Validation>

Refer to the "Page Mode Command Details."

ESC C n

[Name] Set page length to n lines

| | | | | |
|--------|-------------|-----|----|---|
| [Code] | ASCII | ESC | C | n |
| | Hexadecimal | 1B | 43 | n |
| | Decimal | 27 | 67 | n |

[Defined Area] Thermal : $1 \leq n \leq 127$
 Slip : -
 Validation : -

[Initial Value] Thermal : (Form feed amount initial value x 42)
 Slip : -
 Validation : -

[Function]
 <Thermal>

The position whereat this command is processed is considered the top of the page and sets the page length to (current form feed amount x n).

This command cancels the bottom margin setting when setting page length.

The page length set using this command is unaffected by changing the form feed amount later.

Moving to the top of the page is performed using the following commands.

- Form feed command (FF): Execute form feed
- Cutter command (ESC d n): Sets cutter position at top of page.
- Raster command (ESC * r B): Top of page when raster mode ends.
- Error cancel operations: Sets error cancel operation end position at the top of the page.

<Slip>, <Validation>

Only setting is valid

Setting is valid after switching to thermal.

ESC C 0 n

[Name] Set n x 24 mm page length

| | | | | | |
|--------|-------------|-----|----|----|---|
| [Code] | ASCII | ESC | C | 0 | n |
| | Hexadecimal | 1B | 43 | 00 | n |
| | Decimal | 27 | 67 | 0 | n |

[Defined Area] Thermal : $1 \leq n \leq 22$
 Slip : -
 Validation : -

[Initial Value] Thermal : (Form feed amount initial value x 42)
 Slip : -
 Validation : -

[Function]

<Thermal>

The position whereat this command is processed is considered the top of the page and sets the page length to (n x 24 mm).

This command cancels the bottom margin setting when setting page length.

The page length set using this command is unaffected by changing the form feed amount later. Moving to the top of the page is performed using the following commands.

- Form feed command (FF): Execute form feed
- Cutter command (ESC d n): Sets cutter position at top of page.
- Raster command (ESC * r B): Top of page when raster mode ends.
- Error cancel operations: Sets error cancel operation end position at the top of the page.

<Slip>, <Validation>

Only setting is valid

Setting is valid after switching to thermal.

VT

[Name] Feed paper to vertical tab position

| | | |
|--------|-------------|----|
| [Code] | ASCII | VT |
| | Hexadecimal | 0B |
| | Decimal | 11 |

| | | | |
|----------------|------------|---|---|
| [Defined Area] | Thermal | : | - |
| | Slip | : | - |
| | Validation | : | - |

| | | | |
|-----------------|------------|---|---|
| [Initial Value] | Thermal | : | - |
| | Slip | : | - |
| | Validation | : | - |

[Function]

<Thermal>

Feeds paper to the next vertical tab position.

This command is ignored if there are no tabs set.

If a vertical tab is set, and the current position is the same as the vertical tab position, or if it is below that position, it feeds paper to the top of the next page.

If data exists in the line buffer when feeding paper to the vertical tab position, it executes the paper feed to the vertical tab position after printing that data.

However, if moved to the vertical tab position by printing data remaining in the buffer, the move to the vertical tab position is considered to have been executed, so a move to the next vertical tab position is not performed.

There is no initial value for the vertical tab.

<Slip>, <Validation>

One byte ignored

ESC B n1 n2 ... nk NUL

[Name] Set vertical tab position

| | | | | | | | | |
|--------|-------------|-----|----|----|----|----|----|-----|
| [Code] | ASCII | ESC | B | n1 | n2 | .. | nk | NUL |
| | Hexadecimal | 1B | 42 | n1 | n2 | .. | nk | 00 |
| | Decimal | 27 | 66 | n1 | n2 | .. | nk | 0 |

[Defined Area] Thermal : $1 \leq n \leq 255, 0 \leq n \leq 16$
 Slip : -
 Validation : -

[Initial Value] Thermal : -
 Slip : -
 Validation : -

[Function]

<Thermal>

Sets the vertical tab to the (current form feed amount x n) position.

All other vertical tabs set before setting the vertical tab using this command are cancelled.

A maximum of 16 vertical tabs can be set. However, the tab position must satisfy the condition of $1 \leq n1 \leq n2 \dots \leq nk$.

When receiving such an illegal code, tabs up to the illegal code are set, but those after the illegal code are discarded up to the NUL code so illegal code tab are not set.

The vertical tab set using this command is unaffected by changing the form feed amount later.

Vertical tabs set using the ESC B NUL command are cleared.

There is no initial value for the vertical tab.

<Slip>, <Validation>

Only setting is valid

Setting is valid after switching to thermal.

ESC B NUL

[Name] Clear vertical tab position

| | | | | |
|--------|-------------|-----|----|-----|
| [Code] | ASCII | ESC | B | NUL |
| | Hexadecimal | 1B | 42 | 00 |
| | Decimal | 27 | 66 | 0 |

[Defined Area] Thermal : -
 Slip : -
 Validation : -

[Initial Value] Thermal : -
 Slip : -
 Validation : -

[Function]

<Thermal>

Clears the currently set vertical tab.

<Slip>, <Validation>

Only setting is valid

Setting is valid after switching to thermal.

3-3-6) Horizontal Direction Printing Position

ESC I n

[Name] Set left margin

| | | | | |
|--------|-------------|-----|-----|---|
| [Code] | ASCII | ESC | I | n |
| | Hexadecimal | 1B | 6C | n |
| | Decimal | 27 | 108 | n |

[Defined Area] Thermal : $0 \leq n \leq 255$
 Slip : $0 \leq n \leq (\text{right margin} - 2) \leq 255$
 Validation : $0 \leq n \leq (\text{right margin} - 2) \leq 255$

[Initial Value] Thermal : $n = 0$
 Slip : $n = 0$
 Validation : $n = 0$

[Function] Uses the left edge as a standard to set the left margin (current ANK character pitch x n).
 Setting this command partway will take affect from the next line.
 Character spacing is included in the character pitch but is unaffected by expansion settings.
 The left margin set using this command is unaffected by changing the character pitch.

<Thermal> The right edge is also the reference for upside-down printing.
 This command is ignored if settings are for a printing region less than 36 mm.

<Slip>, <Validation> The left edge is also the reference for upside-down printing.
 The left margin must be at least a minimum of 18 dots therebetween with the right margin. (*1)
 If the printable region as set by the left and right margins is smaller than one character, including the space between characters, printing is not possible. A question mark (?) is printed instead of the character.
 (*1) More than four characters of 7 x 9 fonts; more than three characters of 5 x 9 fonts (2P=1)
 (when character spacing = 0)
 When page mode is selected, only setting is valid
 Setting is valid after switching to line mode.

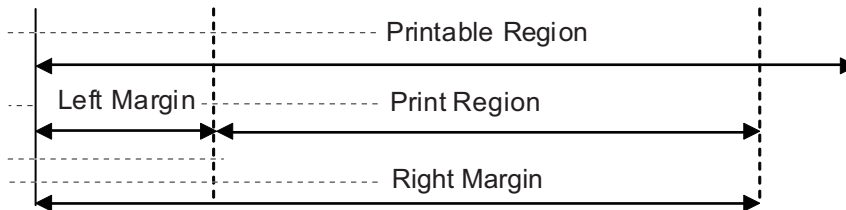

ESC Q n

[Name] Set right margin

| | | | | |
|--------|-------------|-----|----|---|
| [Code] | ASCII | ESC | Q | n |
| | Hexadecimal | 1B | 51 | n |
| | Decimal | 27 | 81 | n |

[Defined Area]

| | | |
|------------|---|--|
| Thermal | : | $0 \leq n \leq 255$ |
| Slip | : | $2 \leq n \leq \text{maximum printable digits} \leq 255$ |
| Validation | : | $2 \leq n \leq \text{maximum printable digits} \leq 255$ |

[Initial Value]

| | | |
|------------|---|--------------------------|
| Thermal | : | - |
| Slip | : | Maximum printable digits |
| Validation | : | Maximum printable digits |

[Function] Uses the left edge as a standard to set the print region as (current ANK character pitch x n). Setting this command partway will take affect from the next line. Character spacing is included in the character pitch but is unaffected by expansion settings. The left margin set using this command is unaffected by changing the character pitch.

<Thermal>

The right edge is also the reference for upside-down printing.
This command is ignored if settings are for a printing region less than 36 mm.

<Slip>, <Validation>

The left edge is also the reference for upside-down printing.
The print region within the defined range must be at least a minimum of 18 dots for the right margin. If the printable region as set by the left and right margins is smaller than one character, including the space between characters, printing is not possible. A question mark (?) is printed instead of the character.

(*1) More than four characters of 7 x 9 fonts; more than three characters of 5 x 9 fonts (2P=1)
(when character spacing = 0)

When page mode is selected, only setting is valid
Setting is valid after switching to line mode.

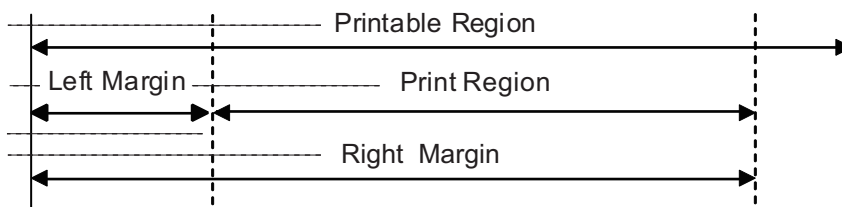

HT

[Name] Move horizontal tab
 [Code] ASCII HT
 Hexadecimal 09
 Decimal 9

[Defined Area] Thermal : -
 Slip : -
 Validation : -
 [Initial Value] Thermal : -
 Slip : -
 Validation : -

[Function] Move print position to next horizontal tab position.
 The current position moves to the next tab position when at the horizontal tab position.

This command is ignored with under the following conditions.

- When there is no horizontal tab set.
 - When the current position is the same as the furthest right horizontal tab position or to the right of it.
- There is no initial value for the horizontal tab.

In the underline/upperline modes, underlines and upperlines are not printed in the spaces created by a horizontal tab.

ESC D n1 n2 ... nk NUL

[Name] Set horizontal tab
 [Code] ASCII ESC D n1 n2 .. nk NUL
 Hexadecimal 1B 44 n1 n2 .. nk 00
 Decimal 27 68 n1 n2 .. nk 0

[Defined Area] Thermal : $1 \leq n \leq 255, 0 \leq n \leq 32$
 Slip : $1 \leq n \leq 255, 0 \leq n \leq 32$
 Validation : $1 \leq n \leq 255, 0 \leq n \leq 32$
 [Initial Value] Thermal : -
 Slip : -
 Validation : -

[Function] Uses the left edge as a standard to set the horizontal tab to the position of (current ANK character pitch x n).
 The horizontal tab reference point is the right edge of the paper, regardless of the left margin.
 ANK character pitches, including right spaces, are unaffected by expansion settings.
 The right edge is also the reference for upside-down printing.
 All other horizontal tabs set before setting the horizontal tab using this command are cancelled
 A maximum of 32 horizontal tabs can be set.
 However, the tab position must satisfy the following conditions.
 If the following conditions are not met, data up to the NUL code is discarded.
 Normal tabs that meet the conditions below are set and tabs after errors occur are not set.

- $1 < n1 < n2 \dots < nk$

The horizontal tab set using this command is unaffected by changing the character pitch.
 Horizontal tabs set using the ESC D NUL command are cleared.
 There is no initial value for the horizontal tab.

(Note) The settings using this command are valid for all stations and modes.

ESC D NUL

[Name] Clear horizontal tab

| | | | | |
|--------|-------------|-----|----|-----|
| [Code] | ASCII | ESC | D | NUL |
| | Hexadecimal | 1B | 44 | 00 |
| | Decimal | 27 | 68 | 0 |

[Defined Area] Thermal : -
Slip : -
Validation : -

[Initial Value] Thermal : -
Slip : -
Validation : -

[Function] Clears the currently set horizontal tab.

(Note) The settings using this command are valid for all stations and modes.

ESC GS A n1 n2

[Name] Move absolute position

| | | | | | | |
|--------|-------------|-----|----|----|----|----|
| [Code] | ASCII | ESC | GS | A | n1 | n2 |
| | Hexadecimal | 1B | 1D | 41 | n1 | n2 |
| | Decimal | 27 | 29 | 65 | n1 | n2 |

[Defined Area] Thermal : $0 \leq n1 \leq 255, 0 \leq n2 \leq 255$
Slip : $0 \leq n1 \leq 255, 0 \leq n2 \leq 255$
Validation : $0 \leq n1 \leq 255, 0 \leq n2 \leq 255$

[Initial Value] Thermal : -
Slip : -
Validation : -

[Function] Moves the printing position from the left margin to the $(n1 + n2 \times 256)$ dot position. This command is ignored if the print region is exceeded. The right margin is also the reference for upside-down printing.

<Thermal> The left margin is also the reference for upside-down printing.

<Slip>, <Validation> The right margin is also the reference for upside-down printing.

ESC GS R n1 n2

[Name] Move relative position

| | | | | | | |
|--------|-------------|-----|----|----|----|----|
| [Code] | ASCII | ESC | GS | R | n1 | n2 |
| | Hexadecimal | 1B | 1D | 52 | n1 | n2 |
| | Decimal | 27 | 29 | 82 | n1 | n2 |

| | | | |
|----------------|------------|---|--|
| [Defined Area] | Thermal | : | $0 \leq n1 \leq 255, 0 \leq n2 \leq 255$ |
| | Slip | : | $0 \leq n1 \leq 255, 0 \leq n2 \leq 255$ |
| | Validation | : | $0 \leq n1 \leq 255, 0 \leq n2 \leq 255$ |

| | | | |
|-----------------|------------|---|---|
| [Initial Value] | Thermal | : | - |
| | Slip | : | - |
| | Validation | : | - |

[Function] Moves the printing position from the current position to the $(n1 + n2 \times 256)$ dot position. This command is ignored if the print region is exceeded.
 When $(n1 + n2 \times 256) \geq 32768$, it moves $\{65536 - (n1 + n2 \times 256)\}$ dots in the left direction.
 When $(n1 + n2 \times 256) < 32768$, it moves $(n1 + n2 \times 256)$ dots in the right direction.
 The right margin is also the reference for upside-down printing.

<Thermal> The left margin is also the reference for upside-down printing.

<Slip>, <Validation> The right margin is also the reference for upside-down printing.

ESC GS a n

[Name] Specify position alignment

| | | | | | |
|--------|-------------|-----|----|----|---|
| [Code] | ASCII | ESC | GS | a | n |
| | Hexadecimal | 1B | 1D | 61 | n |
| | Decimal | 27 | 29 | 97 | n |

[Defined Area] Thermal : $0 \leq n \leq 2, 48 \leq n \leq 50, ("0" \leq n \leq "2")$
 Slip : $0 \leq n \leq 2, 48 \leq n \leq 50, ("0" \leq n \leq "2")$
 Validation : $0 \leq n \leq 2, 48 \leq n \leq 50, ("0" \leq n \leq "2")$

[Initial Value] Thermal : n = 0
 Slip : n = 0
 Validation : n = 0

[Function] This specifies position alignment for all print data in one line, in the set print region.

| n | Position alignment |
|-------|--------------------|
| 0, 48 | Left alignment |
| 1, 49 | Center alignment |
| 2, 50 | Right alignment |

<Slip>, <Validation>

When page mode is selected, only setting is valid
 Setting is valid after switching to line mode.

(Note) The settings by this command are valid for all stations.

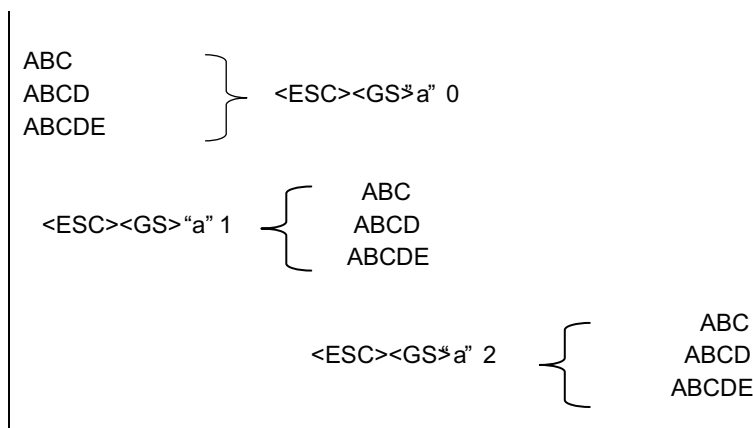

3-3-7) Download

ESC & c1 c2 n d1 . . . d48

[Name] Register 12 x 24 dot font download characters

| | | | | | | | | | |
|--------|-------------|-----|----|----|----|---|----|----|-----|
| [Code] | ASCII | ESC | & | c1 | c2 | n | d1 | .. | d48 |
| | Hexadecimal | 1B | 26 | c1 | c2 | n | d1 | .. | d48 |
| | Decimal | 27 | 38 | c1 | c2 | n | d1 | .. | d48 |

[Defined Area] Thermal : c1 = 1, 49, c2 = 1, 49, 32 ≤ n ≤ 127, 0 ≤ d ≤ 255
 Slip : -
 Validation : -
 [Initial Value] Thermal : -
 Slip : -
 Validation : -

[Function]
 <Thermal>

Registers 12 x 24 dot font download characters to the nth address.
 Download characters can be registered to <20>H to <7F>H. (96 characters can be registered for each font.)
 Those already registered to these addresses are overwritten.
 When parameters c1 and c2 and n are outside of the defined area, subsequent data is handled as normal data.

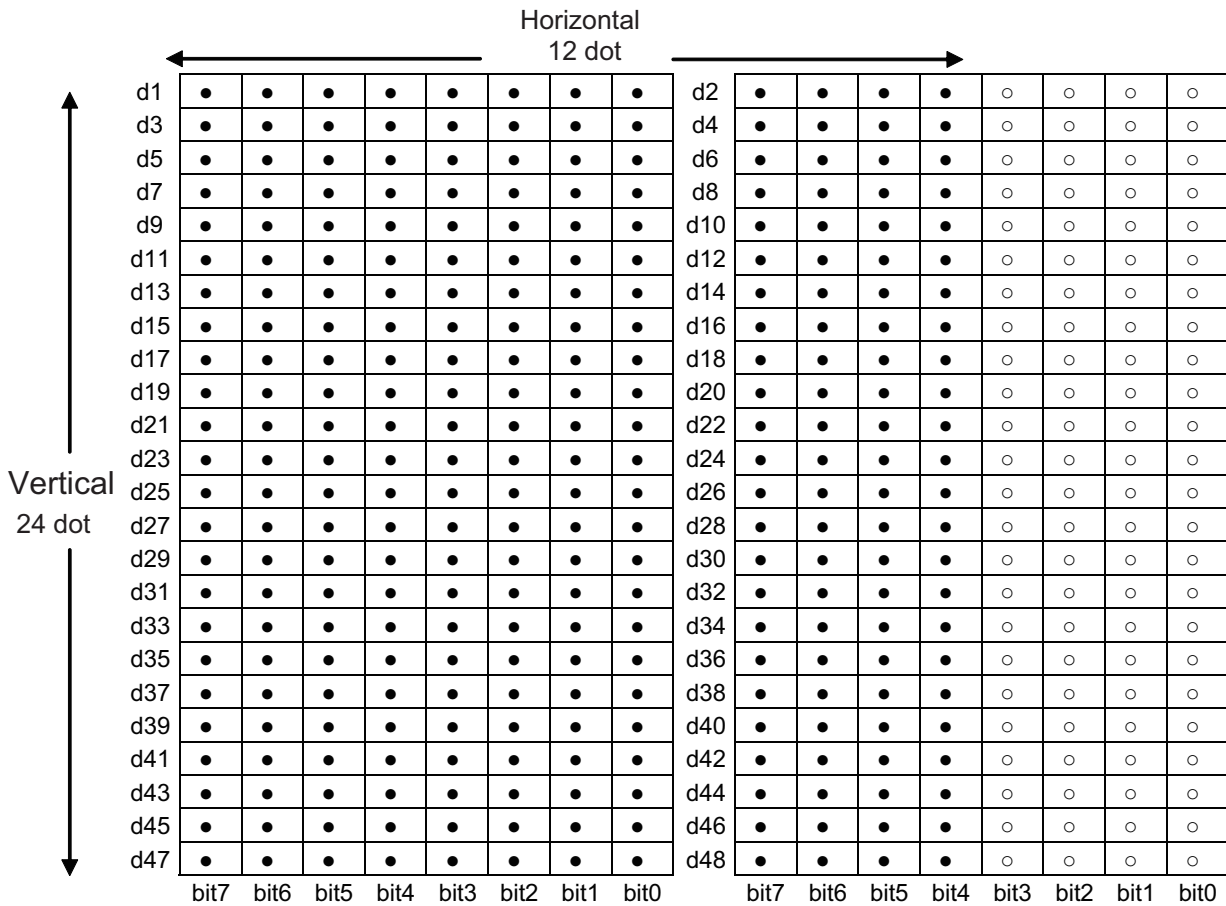

● : Font data
 ○ : Invalid data

<Slip>, <Validation>

Only registration is possible.
 Registration data is printable after switching to thermal.

ESC & c1 c2 n

[Name] Delete 12 x 24 dot font download characters

| | | | | | | |
|--------|-------------|-----|----|----|----|---|
| [Code] | ASCII | ESC | & | c1 | c2 | n |
| | Hexadecimal | 1B | 26 | c1 | c2 | n |
| | Decimal | 27 | 38 | c1 | c2 | n |

[Defined Area] Thermal : c1 = 1, 49, c2 = 0, 48, $32 \leq n \leq 127$
 Slip : -
 Validation : -

[Initial Value] Thermal : -
 Slip : -
 Validation : -

[Function]

<Thermal>

Deletes 12 x 24 dot font download characters registered to the nth address.

<Slip>, <Validation>

Deleting is possible.

ESC & NUL n1 n2 [m d1 d2 d3 d4 d5 (d6 d7)] n2 - n1 + 1

[Name] Register download characters

| | | | | | | | | |
|--------|-------------|-----|----|-----|----|----|----------------------------|-------------|
| [Code] | ASCII | ESC | & | NUL | n1 | n2 | [m d1 d2 d3 d4 d5 (d6 d7)] | n2 - n1 + 1 |
| | Hexadecimal | 1B | 26 | 00 | n1 | n2 | [m d1 d2 d3 d4 d5 (d6 d7)] | n2 - n1 + 1 |
| | Decimal | 27 | 38 | 0 | n1 | n2 | [m d1 d2 d3 d4 d5 (d6 d7)] | n2 - n1 + 1 |

[Defined Area] Thermal : -
 Slip : $33 \leq n1 \leq n2 \leq 127$ ($21h \leq n1 \leq n2 \leq 7Fh$), $m = 0, 128$ (00h, 80h), $0 \leq d1$ to $d7 \leq 255$
 Validation : $33 \leq n1 \leq n2 \leq 127$ ($21h \leq n1 \leq n2 \leq 7Fh$), $m = 0, 128$ (00h, 80h), $0 \leq d1$ to $d7 \leq 255$

[Initial Value] Thermal : -
 Slip : -
 Validation : -

[Function]
 <Thermal>

Only registration is possible.
 Registration data is printable after switching to slip or validation.

<Slip>, <Validation>

Registers download characters to the specified character code.
 A maximum of 22 download characters can be registered for 7 x 9 and 5 x 9 fonts.
 The range of the location to write download characters is specified by n1 and n2. (When there is one character to register, n1 = n2.)
 If one has been already registered to an address, it is overwritten.
 This command registers download characters independent to each font.
 m indicates the relationship of the character pattern and the print head (see figure below).
 Definition data (d1 to d7) set the bits that correspond to the dots to print to "1," and the bits that correspond to the dots that are not printed to "0."
 Even if ESC @ (command initialization) is executed, the registered download character is not cleared.
 Registered data is shared by slip and validation.

Relationship of character pattern data and print head.

1. When m = 0 (00h)

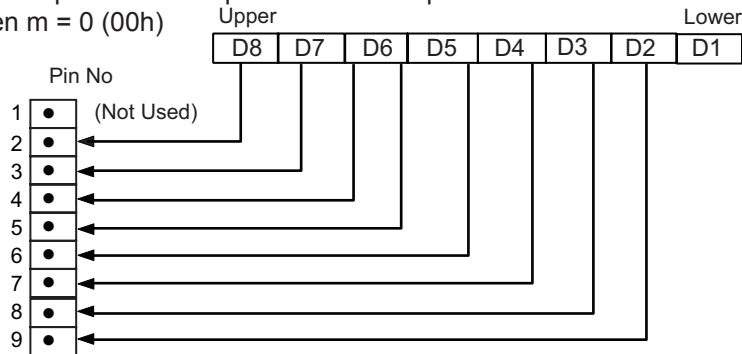

2. When m = 128 (80h)

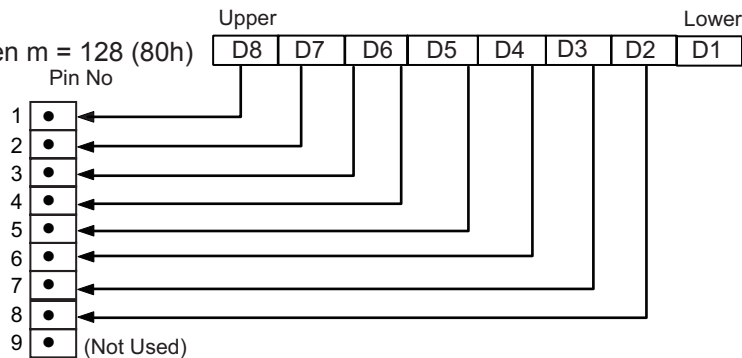

(Note) • When registering 7 x 9 fonts, dots adjacent in the horizontal direction do not print.
 •When character rotation is specified, 7 x 9 font registered characters cannot be printed. 5 x 9 font characters are always printed.

[Ex.:] When selecting 7 x 9 fonts, and defining the character to 21H:

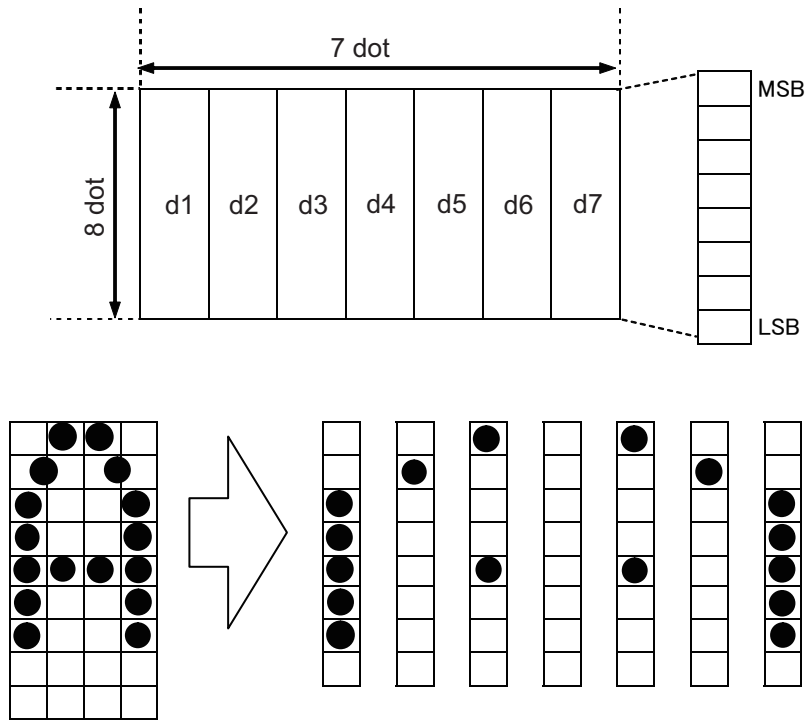

ESC & NUL n1 n2 m d1 d2 d3 d4 d5 d6 d7
 Code (Hexadecimal) 1B 26 00 21 21 80 3E 40 88 00 88 40 3E
 (1 when printing corresponding bits, and 0 for no print))

[Ex.:] When selecting 5 x 9 fonts, and defining the character to 21H:

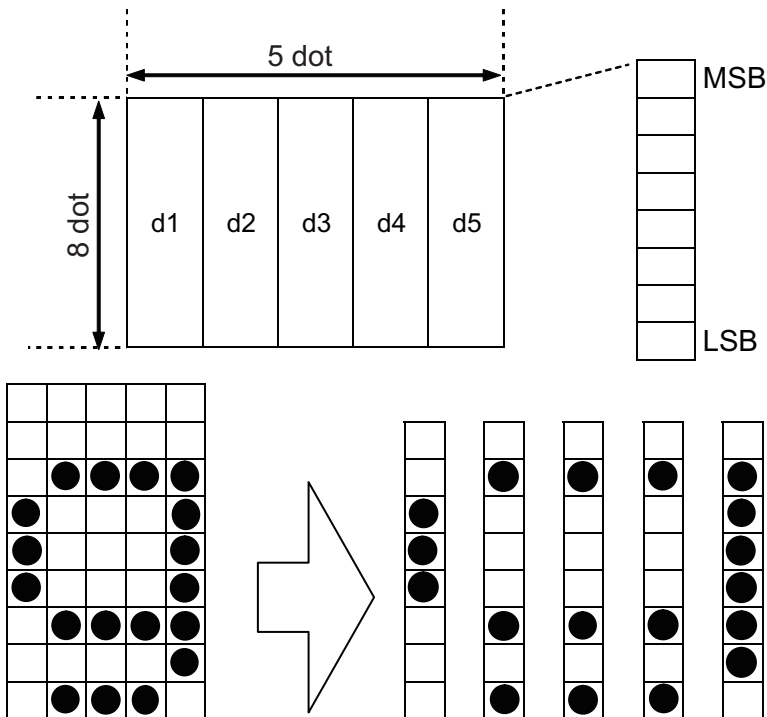

ESC & NUL n1 n2 m d1 d2 d3 d4 d5
 Code (Hexadecimal) 1B 26 00 21 21 00 38 45 45 45 7E
 (1 when printing corresponding bits, and 0 for no print))

ESC % N

[Name] Specify/cancel ANK download characters

| | | | | |
|--------|-------------|-----|----|---|
| [Code] | ASCII | ESC | % | n |
| | Hexadecimal | 1B | 25 | n |
| | Decimal | 27 | 37 | n |

[Defined Area] Thermal : n = 0, 1, 48, 49
 Slip : n = 0, 1, 48, 49
 Validation : n = 0, 1, 48, 49

[Initial Value] Thermal : Cancel ANK download character
 Slip : Cancel ANK download character
 Validation : Cancel ANK download character

[Function] Specifies/cancels ANK download characters

| n | Download characters |
|-------|---------------------------------|
| 0, 48 | Cancel ANK download characters |
| 1, 49 | Specify ANK download characters |

<Print example of download characters>

1. Registration of ANK download character (ESC & c1 c2 n d1...d48)
2. Specify ANK download characters (ESC % n (n = 1))
3. Print ANK download characters

(Note) The settings using this command are valid for all stations and modes.

3-3-8) Bit Image Graphics

ESC K n1 n2 d1 ... dk

[Name] Standard density bit image

| | | | | | | | | |
|--------|-------------|-----|----|----|----|----|----|----|
| [Code] | ASCII | ESC | K | n1 | n2 | d1 | .. | dk |
| | Hexadecimal | 1B | 4B | n1 | n2 | d1 | .. | dk |
| | Decimal | 27 | 75 | n1 | n2 | d1 | .. | dk |

[Defined Area] Thermal : $1 \leq \{(n1 + n2 \times 256) \times 3\} \leq$ printable region

$$k = (n1 + n2 \times 256)$$

$$0 \leq d \leq 255$$

Slip :

$$1 \leq (n1 + n2 \times 256) \leq$$
 printable region (total dot count)

$$k = (n1 + n2 \times 256)$$

$$0 \leq d \leq 255$$

Validation :

$$1 \leq (n1 + n2 \times 256) \leq$$
 printable region (total dot count)

$$k = (n1 + n2 \times 256)$$

$$0 \leq d \leq 255$$

[Initial Value] Thermal : -

Slip : -

Validation : -

[Function]
<Thermal>

Prints bit images using 3 dots wide and 3 dots high per 1 dot of input data.

The following shows the details of data processing with this command.

- When $\{(n1 + n2 \times 256) \times 3\}$ exceeds the printable region, only the data in the printing region is printed.
- When $\{(n1 + n2 \times 256) \times 3\}$ exceeds the currently set printable region, only the data in the printing region is printed.
At this time, all data for the print region is discarded.
- If the current position already exceeds the print region, this command discards all data.

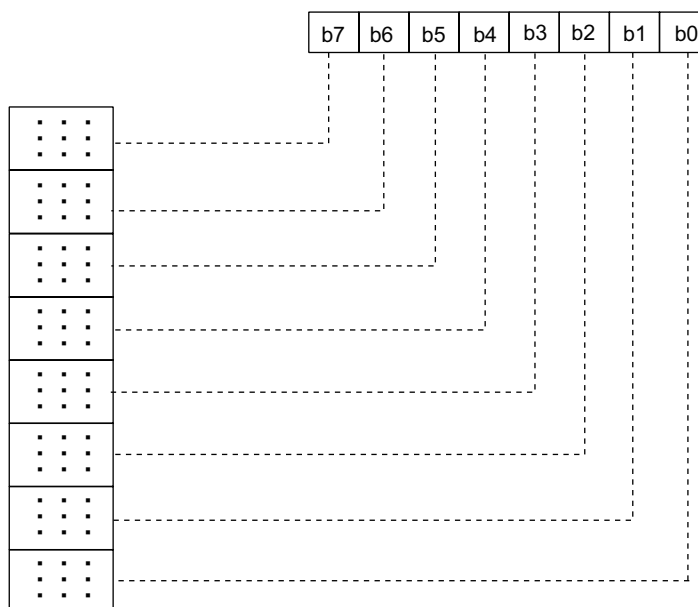

<Slip>, <Validation>

This command prints bit images with only the data count determined by n1.

The amount of data that can be printed in one line is limited to the total dot count. Data that exceeds the total dot count or the right margin is ignored.

See each printer's product specifications manual for details regarding the total dot count.

After printing the bit image, the printer automatically returns to the character mode.

The following drawing shows the relationship of the print head needle wires and the data.

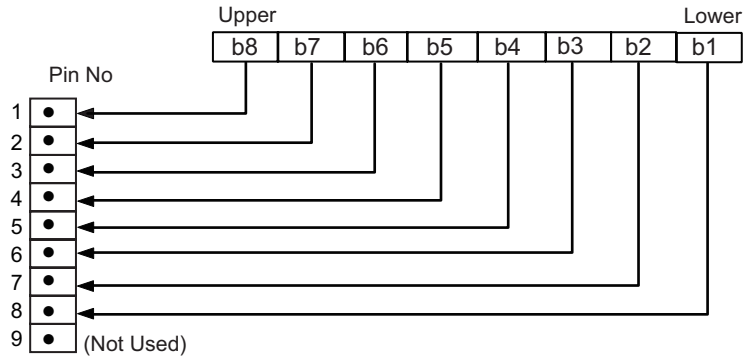

ESC L n1 n2 d1 ... dk

[Name] High density bit image

| | | | | | | | | |
|--------|-------------|-----|----|----|----|----|----|----|
| [Code] | ASCII | ESC | L | n1 | n2 | d1 | .. | dk |
| | Hexadecimal | 1B | 4C | n1 | n2 | d1 | .. | dk |
| | Decimal | 27 | 76 | n1 | n2 | d1 | .. | dk |

[Defined Area] Thermal : $1 \leq \{(n1 + n2 \times 256) \leq \text{printable region}\}$
 $k = (n1 + n2 \times 256)$
 $0 \leq d \leq 255$

Slip : $1 \leq (n1 + n2 \times 256) \leq \text{printable region (total half-dot count)}$
 $k = (n1 + n2 \times 256)$
 $0 \leq d \leq 255$

Validation : $1 \leq (n1 + n2 \times 256) \leq \text{printable region (total half-dot count)}$
 $k = (n1 + n2 \times 256)$
 $0 \leq d \leq 255$

[Initial Value] Thermal : -
 Slip : -
 Validation : -

[Function]
 <Thermal>

Prints bit images using 1 dots wide and 3 dots high per 1 dot of input data.

The following shows the details of data processing with this command.

- When $(n1 + n2 \times 256)$ exceeds the printable region, only data in the print region is printed.
- When $(n1 + n2 \times 256)$ exceeds the currently set printable region, only the data in the printing region is printed.

At this time, all data for the print region is discarded.

- If the current position already exceeds the print region, this command discards all data.

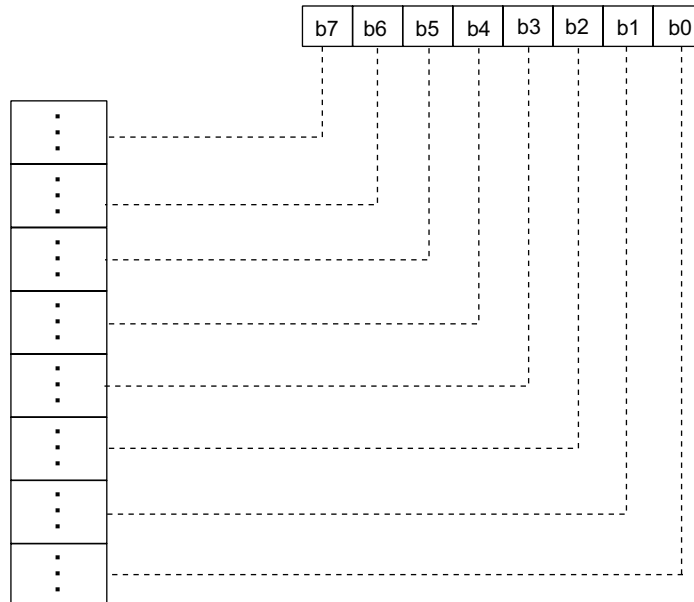

<Slip>, <Validation>

This command executes the bit image of a density doubled (half dot printing) for just the data count determined by n1 and n2.

The amount of data that can be printed in one line is only the total half-dot count. Data that exceeds the total half-dot count or the right margin is ignored.

See each printer's product specifications manual for details regarding the total half-dot count.

The relationship of the print head needle wires and the data is the same as ESC K (standard density bit image).

When printing double-density bit images, dots adjacent in the horizontal direction do not print.

After printing the bit image, the printer automatically returns to the character mode.

When page mode is selected, all data is received and discarded.

ESC k n1 n2 d1 ... dk

[Name] Fine bit image

| | | | | | | | | |
|--------|-------------|-----|-----|----|----|----|----|----|
| [Code] | ASCII | ESC | k | n1 | n2 | d1 | .. | dk |
| | Hexadecimal | 1B | 6B | n1 | n2 | d1 | .. | dk |
| | Decimal | 27 | 107 | n1 | n2 | d1 | .. | dk |

[Defined Area] Thermal : n2 = 0
 $1 \leq \{(n1 + n2 \times 256) \times 8\} \leq \text{printable region}$
 $k = \{(n1 + n2 \times 256) \times 24\}$
 $0 \leq d \leq 255$

Slip : -
 Validation : -

[Initial Value] Thermal : -
 Slip : -
 Validation : -

[Function]
 <Thermal>

Prints bit images using 1 dots wide and 1 dots high per 1 dot of input data.
 The following shows the details of data processing with this command.

- When $\{(n1 + n2 \times 256) \times 8\}$ exceeds the printable region, only the data in the printing region is printed.
- When $\{(n1 + n2 \times 256) \times 8\}$ exceeds the currently set printable region, only the data in the printing region is printed.

At this time, all data for the print region is discarded.

- If the current position already exceeds the print region, this command discards all data.

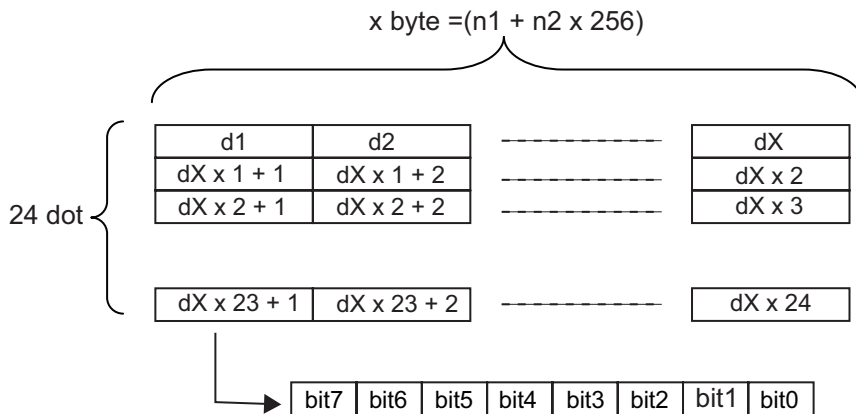

<Slip>, <Validation>
 All data received and discarded.

ESC X n1 n2 d1 ... dk

[Name] Fine density bit image (Wire-dot, 24 pin compatible)

| | | | | | | | | |
|--------|-------------|-----|----|----|----|----|----|----|
| [Code] | ASCII | ESC | X | n1 | n2 | d1 | .. | dk |
| | Hexadecimal | 1B | 58 | n1 | n2 | d1 | .. | dk |
| | Decimal | 27 | 88 | n1 | n2 | d1 | .. | dk |

[Defined Area] Thermal : $1 \leq (n1 + n2 \times 256) \leq \text{printable region}$
 $k = \{(n1 + n2 \times 256) \times 3\}$
 $0 \leq d \leq 255$

Slip : -

Validation : -

[Initial Value] Thermal : -

Slip : -

Validation : -

[Function]
 <Thermal>

Prints input bit images with 8 dots/mm resolution for both horizontal and vertical.
 The following shows the details of data processing with this command.

- When $\{(n1 + n2 \times 256) \times 3\}$ exceeds the printable region, only the data in the printing region is printed.
- When $\{(n1 + n2 \times 256) \times 3\}$ exceeds the currently set printable region, only the data in the printing region is printed.

At this time, all data for the print region is discarded.

- If the current position already exceeds the print region, this command discards all data.

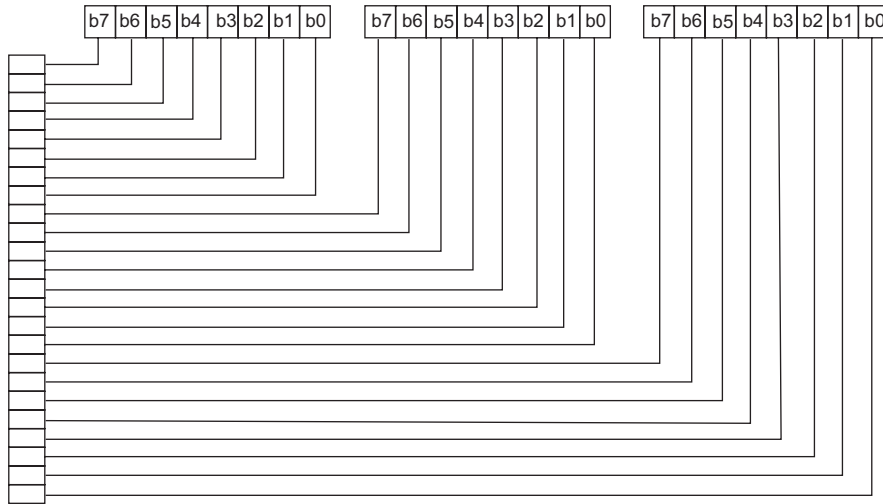

<Slip>, <Validation>

All data received and discarded.

ESC ^ m n1 n2 d1 d2 ... dk

[Name] 9 Dot bit image

| | | | | | | | | | | |
|--------|-------------|-----|----|---|----|----|----|----|----|----|
| [Code] | ASCII | ESC | ^ | m | n1 | n2 | d1 | d2 | .. | dk |
| | Hexadecimal | 1B | 5E | m | n1 | n2 | d1 | d2 | .. | dk |
| | Decimal | 27 | 94 | m | n1 | n2 | d1 | d2 | .. | dk |

[Defined Area] Thermal : -
 Slip : $0 \leq m \leq 1$ ("0" $\leq m \leq$ "1")
 Validation : $0 \leq m \leq 1$ ("0" $\leq m \leq$ "1")

[Initial Value] Thermal : -
 Slip : -
 Validation : -

[Function]
 <Thermal>

All data received and discarded.

<Slip>, <Validation>

This command prints bit images with only the data count determined by n1, and n2 at standard or double density.

Specify the horizontal print dot count (row) using n1 + n2 x 256 dots.

- m = 0: Print standard density 9 dot bit images.
 The maximum number of dots in the horizontal direction is the total number of dots.
- m = 1: Print double density 9 dot bit images.
 The maximum number of dots in the horizontal direction is the total number of half dots.
 Dots adjacent in the horizontal direction do not print.
 When page mode is selected, all data is received and discarded.

(Note) • Data exceeding the maximum number of dots or the right margin is ignored.

- **Total number of dots and total number of half-dots follows the memory switch setting. (See the specifications manual)**
- **If m is outside of the definition, data after n1 is processed as normal data.**
- **When printing of the bit image is ended, the system returns to normal data processing.**

The following drawing shows the relationship of the print head needle wires and the data.

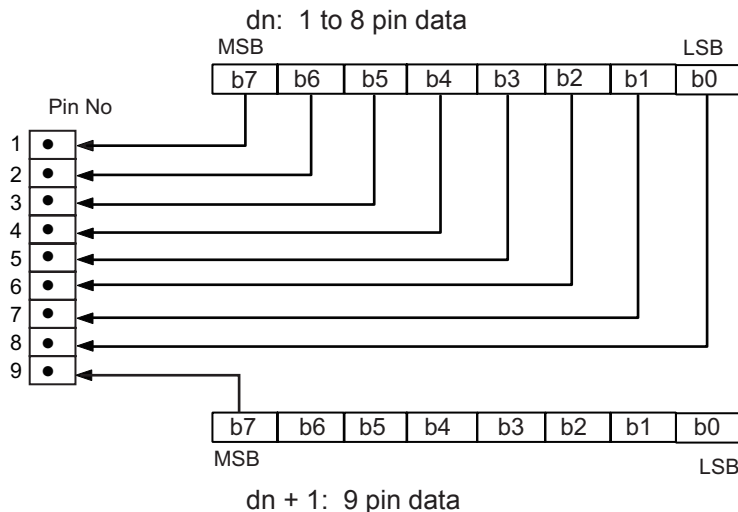

3-3-9) Logo

ESC FS q n [x11 x12 y11 y12 d1 ... dk]1 ... [xn1 xn2 yn1 yn2 d1 ... dk] n

| | | | | | | | | | | | | | | | | | | | | |
|--------|---------------|-----|----|-----|---|------|-----|-----|-----|----|----|------|----|------|-----|-----|-----|----|----|------|
| [Name] | Register logo | | | | | | | | | | | | | | | | | | | |
| [Code] | ASCII | ESC | FS | q | n | [x11 | x12 | y11 | y12 | d1 | .. | dk]1 | .. | [xn1 | xn2 | yn1 | yn2 | d1 | .. | dk]n |
| | Hexadecimal | 1B | 1C | 71 | n | [x11 | x12 | y11 | y12 | d1 | .. | dk]1 | .. | [xn1 | xn2 | yn1 | yn2 | d1 | .. | dk]n |
| | Decimal | 27 | 28 | 113 | n | [x11 | x12 | y11 | y12 | d1 | .. | dk]1 | .. | [xn1 | xn2 | yn1 | yn2 | d1 | .. | dk]n |

| | | | |
|----------------|------------|---|--|
| [Defined Area] | Thermal | : | $1 \leq n \leq 255$ $0 \leq xn1 \leq 255, 0 \leq xn2 \leq 3 \quad 1 \leq (xn1 + xn2 \times 256) \leq 1023$ $0 \leq yn1 \leq 255, 0 \leq yn2 \leq 1 \quad 1 \leq (yn1 + yn2 \times 256) \leq 288$ $0 \leq d \leq 255$ $k = \{(xn1 + xn2 \times 256) \times (yn1 + yn2 \times 256) \times 8\}$ |
| | Slip | : | $1 \leq n \leq 255$ $0 \leq xn1 \leq 255, 0 \leq xn2 \leq 3 \quad 1 \leq (xn1 + xn2 \times 256) \leq 1023$ $0 \leq yn1 \leq 255, 0 \leq yn2 \leq 1 \quad 1 \leq (yn1 + yn2 \times 256) \leq 288$ $0 \leq d \leq 255$ $k = \{(xn1 + xn2 \times 256) \times (yn1 + yn2 \times 256) \times 8\}$ |
| | Validation | : | $1 \leq n \leq 255$ $0 \leq xn1 \leq 255, 0 \leq xn2 \leq 3 \quad 1 \leq (xn1 + xn2 \times 256) \leq 1023$ $0 \leq yn1 \leq 255, 0 \leq yn2 \leq 1 \quad 1 \leq (yn1 + yn2 \times 256) \leq 288$ $0 \leq d \leq 255$ $k = \{(xn1 + xn2 \times 256) \times (yn1 + yn2 \times 256) \times 8\}$ |

| | | | |
|-----------------|------------|---|-----------------|
| [Initial Value] | Thermal | : | No registration |
| | Slip | : | No registration |
| | Validation | : | No registration |

- [Function] Register logo
 Parameter details
- n: Specifies registered logo count
 - xn1, xn2: Horizontal size of registered logo $\{(xn1 + xn2 \times 256) \times 8\}$ dots
 - yn1, yn2: Vertical size of registered logo $\{(yn1 + yn2 \times 256) \times 8\}$ dots
 - d: Registered logo data
 - k: Logo data count

This command should be specified at the top of the line.
 When the first parameter is determined to be free of error, the printer starts processing this command.
 When logo register processing starts, all previously defined data is deleted.(It is not possible to re-register a portion of a plurality of defined logo data.)
 Logo registration numbers are defined in rising order from 1.
 If the defined area specified by the parameter is not empty, or if there is an error in the parameter specification, register processing is aborted.(The pre-registered and complete data is effective.)
 The printer should be reset if logo registration is completed or register processing is aborted.
 If an error occurs while performing register processing (the time from when the first parameter is OK until the printer initialization is completed after registering a logo), error processing, mechanical operation and status processing cannot be performed. Also, data must not be sent from the host during that time.
 This command is executed only for logo registration and does not accompany the printing operation. Logos are printed using the ESC FS p (print NV logo) command.
 The NV memory capacity is 4 Mbits (512 Kbytes 524,288 bytes).
 However, 4 Kbytes (4,096 bytes) are kept as parameter information separate to the data so the data region memory capacity is 520,192 Bytes.

Ex.: When the registered data size per each one is 6 Kbytes (6,144 bytes), it is possible to register $520,192/6144 = 84$.

ESC FS p n m

[Name] Print logo

| | | | | | | |
|--------|-------------|-----|----|-----|---|---|
| [Code] | ASCII | ESC | FS | p | n | m |
| | Hexadecimal | 1B | 1C | 70 | n | m |
| | Decimal | 27 | 28 | 112 | n | m |

[Defined Area] Thermal : $1 \leq n \leq 255$
 $0 \leq m \leq 3, 48 \leq m \leq 51, ("0" \leq m \leq "3")$
 Slip : $1 \leq n \leq 255$
 $0 \leq m \leq 3, 48 \leq m \leq 51, ("0" \leq m \leq "3")$
 Validation : $1 \leq n \leq 255$
 $0 \leq m \leq 3, 48 \leq m \leq 51, ("0" \leq m \leq "3")$

[Initial Value] Thermal : -
 Slip : -
 Validation : -

[Function] Prints the logo of registration number n registered using the logo registration command ESC FS q according to the print mode m.

n: Logo Specification

| n | Function |
|----------|-----------------------|
| 1 to 255 | Specified logo number |

m: Print Mode

| m | Logo Print Mode |
|-------|-----------------------------|
| 0, 48 | Normal mode |
| 1, 49 | Horizontal double size mode |
| 2, 50 | Vertical double size mode |
| 3, 51 | Double high/wide mode |

- If the parameter is within the defined region, execute this command after printing the unprinted data in the line buffer.
 (Unprinted data is printed regardless of whether the specified logo was registered by n.))
- It is not possible to print with other data in the same line (characters, bit images, bar codes).
- Form feed obeys the vertical print size of the logo.
- Print modes, excluding upside-down printing (enhanced, double, underline, character size, black/white inverted, and 90° right rotation) are unaffected.
- If the logo horizontal print size exceeds the horizontal print region, the portion exceeding the area is not printed.
- When page mode is selected, supports only vertical double high, and horizontal double wide modes.
- Logos are printed according to the following command settings.
 - Left margin (ESC I n)
 - Right margin (ESC Q n)
 - Position alignment (ESC GS a n)
 - Absolute position movement (ESC GS A n1 n2)
 - Relative position movement (ESC GS R n1 n2)
 - Horizontal tab (HT)
 - Upside-down printing (SI)

ESC RS L m

[Name] Logo batch control

[Code] ASCII ESC RS L m
 Hexadecimal 1B 1E 4C m
 Decimal 27 30 76 m

[Defined Area] Thermal : 0 ≤ m ≤ 3, 48 ≤ m ≤ 51, ("0" ≤ m ≤ "3"), m = 255
 Slip : 0 ≤ m ≤ 3, 48 ≤ m ≤ 51, ("0" ≤ m ≤ "3"), m = 255
 Validation : 0 ≤ m ≤ 3, 48 ≤ m ≤ 51, ("0" ≤ m ≤ "3"), m = 255

[Initial Value] Thermal : -
 Slip : -
 Validation : -

[Function] Controls logos specified by the parameter m.
 After execution, resets the printer.

m: Print Mode

| m | Logo Control Mode |
|-------|--|
| 0, 48 | Normal mode batch printing |
| 1, 49 | Horizontal double size mode batch printing |
| 2, 50 | Vertical double size mode batch printing |
| 3, 51 | Double high/wide mode batch printing |
| 255 | Logo batch delete |

- If the parameter is within the defined region, execute this command after printing the unprinted data in the line buffer.
 (Unprinted data is printed regardless of whether the specified logo was registered by n.))
- Form feed obeys the vertical print size of the logo.
- Print modes, excluding upside-down printing (enhanced, double, underline, character size, black/white inverted, and 90° right rotation) are unaffected by logos.
- Prints logo number as shown below in the line above each logo print.
 This line is printed with ANK characters, so currently set adornment is applied.
 (Print Ex.) "LOGO No. 1" (Each logo number is printed at the "1" position.)
- If the logo horizontal print size exceeds the horizontal print region, the portion exceeding the area is not printed.
- This test print is affected by the following command settings.
 - Left margin (ESC I n)
 - Right margin (ESC Q n)
 - Position alignment (ESC GS a n)
 - Print region setting (ESC RS A n)
 - Upside-down printing (SI)
- After batch printing output is ended, paper is fed automatically to the cutting position, paper is cut (if the printer is equipped with a cutter), and the printer is reset.

<Slip>, <Validation>

When page mode is selected, four bytes ignored.

3-3-10) Bar Codes

ESC b n1 n2 n3 n4 d1 . . . dk RS

[Name] Print bar code

| | | | | | | | | | | | |
|--------|-------------|-----|----|----|----|----|----|----|----|----|----|
| [Code] | ASCII | ESC | b | n1 | n2 | n3 | n4 | d1 | .. | dk | RS |
| | Hexadecimal | 1B | 62 | n1 | n2 | n3 | n4 | d1 | .. | dk | 1E |
| | Decimal | 27 | 98 | n1 | n2 | n3 | n4 | d1 | .. | dk | 30 |

[Defined Area] Thermal : $0 \leq n1 \leq 8, 48 \leq n1 \leq 56$ ("0" $\leq n1 \leq$ "8")
 $1 \leq n2 \leq 4, 49 \leq n2 \leq 52$ ("1" $\leq n2 \leq$ "4")
 $1 \leq n4 \leq 255$
 n3 (bar code mode), d (bar code data),
 Defined area of k (bar code data count) is different depending on the bar code type.

Slip : -
 Validation : -

[Initial Value] Thermal : -
 Slip : -
 Validation : -

[Function]
 <Thermal>

Bar code printing is executed according to the following parameters.
 If n1, n2, n3 and n4 are acquired and detected to be out of the defined area, data up to RS is discarded.

• n1: Bar Code Type Selection

| n1 | Bar Codes Types |
|-------|-----------------|
| 0, 48 | UPC-E |
| 1, 49 | UPC-A |
| 2, 50 | JAN/EAN8 |
| 3, 51 | JAN/EAN13 |
| 4, 52 | Code39 |
| 5, 53 | ITF |
| 6, 54 | Code128 |
| 7, 55 | Code93 |
| 8, 56 | NW-7 |

• n2: Character Selection Under Bar Code, and Line Feed Addition Selection

| n2 | Under-bar character selection and added line feed selection |
|-------|--|
| 1, 49 | No added under-bar charactersExecutes a form feed after bar code is printed. |
| 2, 50 | Added under-bar charactersExecutes a form feed after bar code is printed. |
| 3, 51 | No added under-bar charactersDoes not execute a form feed after bar code is printed. |
| 4, 52 | Added under-bar charactersDoes not execute a form feed after bar code is printed. |

• n3: Bar Code Mode Selection

| n3 | Bar Codes Types | | |
|-------|--|---------------------------|---------------------------|
| | UPC-E, UPC-A, JAN/EAN8 JAN/EAN13, Code128, Code93 | Code39, NW-7 | ITF |
| 1, 49 | Minimum module 2 dots | Narrow : Wide = 2: 6 dots | Narrow : Wide = 2: 5 dots |
| 2, 50 | Minimum module 3 dots | Narrow : Wide = 3: 9 dots | Narrow : Wide = 4:10 dots |
| 3, 51 | Minimum module 4 dots | Narrow : Wide = 4:12 dots | Narrow : Wide = 6:15 dots |
| 4, 52 | --- | Narrow : Wide = 2: 5 dots | Narrow : Wide = 2: 4 dots |
| 5, 53 | --- | Narrow : Wide = 3: 8 dots | Narrow : Wide = 4: 8 dots |
| 6, 54 | --- | Narrow : Wide = 4:10 dots | Narrow : Wide = 6:12 dots |
| 7, 55 | --- | Narrow : Wide = 2: 4 dots | Narrow : Wide = 2: 6 dots |
| 8, 56 | --- | Narrow : Wide = 3: 6 dots | Narrow : Wide = 3: 9 dots |
| 9, 57 | --- | Narrow : Wide = 4: 8 dots | Narrow : Wide = 4:12 dots |

• n4: Bar code height (dot count)

Spec. 1: When the height of the bar code is more than the form feed amount, the form feed amount is automatically doubled.

Spec. 2: Line feed according to (bar code height + under-bar characters)

• k (bar code data count), d (bar code data)

| Bar Codes Types | Defined area of k | Defined area of d |
|-----------------|--|--|
| UPC-E | $11 \leq k \leq 12$ | $48 \leq d \leq 57$ ("0" \leq d \leq "9") |
| UPC-A | $11 \leq k \leq 12$ | $48 \leq d \leq 57$ ("0" \leq d \leq "9") |
| JAN/EAN8 | $7 \leq k \leq 8$ | $48 \leq d \leq 57$ ("0" \leq d \leq "9") |
| JAN/EAN13 | $12 \leq k \leq 13$ | $48 \leq d \leq 57$ ("0" \leq d \leq "9") |
| Code39 | $1 \leq k$ | $48 \leq d \leq 57$ ("0" \leq d \leq "9"), $65 \leq d \leq 90$ ("A" \leq d \leq "Z") 32, 36, 37, 43, 45, 46, 47(SP, "\$", "%", "+", "-", ".", "/") |
| ITF | $1 \leq k$ For odd numbers 0 data is automatically added to the top. | $48 \leq d \leq 57$ ("0" \leq d \leq "9") |
| Code128 | $1 \leq k$ | $0 \leq d \leq 127$ |
| Code93 | $1 \leq k$ | $0 \leq d \leq 127$ |
| NW-7 | $1 \leq k$ | $48 \leq d \leq 57$ ("0" \leq d \leq "9"), $65 \leq d \leq 68$ ("A" \leq d \leq "D") 36, 43, 45, 46, 47, 58 ("\$", "+", "-", ".", "/", ".") 97, 98, 99, 100 ("a," "b," "c," "d") |

• UPC-E: k = 11 (or 12)

The 12th check digit is automatically applied, so it is ignored even if specified.

Command is ignored if the data cannot be shortened. Data conversion to rectangles is automatic.

• UPC-A: k = 11 (or 12)

The 12th check digit is automatically applied, so it is ignored even if specified.

• JAN/EAN -8: k = 7 (or 8)

The 8th check digit is automatically applied, so it is ignored even if specified.

• JAN/EAN -13: k = 12 (or 13)

The 13th check digit cannot be automatically applied, so it is ignored even if specified.

• CODE39: k is freely set, and maximum value differs according to the mode.

Start and stop codes (*) are automatically included.

• ITF: k is freely set, and maximum value differs according to the mode.

If the data is an odd line, 0 data is automatically appended to the top.

• CODE128: k is freely set, and maximum value differs according to the mode and print character type.

Check character is automatically appended.

• CODE93: k is freely set, and maximum value differs according to the mode and print character type.

The start/stop code (□) is automatically appended.

• NW7: k is freely set, and maximum value differs according to the mode and print character type.

Both start/stop codes are included in the data (but not automatically applied).

3-3-11) Cutter Control

ESC d n

[Name] Auto-cutter:

| | | | | |
|--------|-------------|-----|-----|---|
| [Code] | ASCII | ESC | d | n |
| | Hexadecimal | 1B | 64 | n |
| | Decimal | 27 | 100 | n |

[Defined Area] Thermal : $0 \leq d \leq 3$,
 $48 \leq d \leq 51$ ("0" $\leq d \leq$ "3")

Slip : -
 Validation : -

[Initial Value] Thermal : -
 Slip : -
 Validation : -

[Function]
 <Thermal>

Executes the auto-cutter.
 After auto-cutter is executed, the printer considers that position to be the top of the page.

| n | Auto-cutter |
|-------|--|
| 0, 48 | Full cut at the current position. Print data in line buffer is printed before a full cut. Models not provided the auto-cutter execute only functions other than the cutting operation (printing/paper feed operations). |
| 1, 49 | Partial cut at the current position. Print data in line buffer is printed before a partial cut. Models not provided the auto-cutter execute only functions other than the cutting operation (printing/paper feed operations). |
| 2, 50 | Paper is fed to cutting position, then a full cut. Print data in line buffer is printed before the operation described above. Models not provided the auto-cutter execute only functions other than the cutting operation (printing/paper feed operations). |
| 3, 51 | Paper is fed to cutting position, then a partial cut. Print data in line buffer is printed before the operation described above. Models not provided the auto-cutter execute only functions other than the cutting operation (printing/paper feed operations). |

(*) The auto-cutter function operates in the following ways on models that only have a full cut or a partial cut.

- Models that perform only a full cut.: Executes a full cut when for instructions calling for a partial cut.
- Models that perform only a partial cut.: Executes a partial cut when for instructions calling for a full cut.

<Slip>, <Validation>
 Three bytes ignored

3-3-12) External Device Drive

ESC BEL n1 n2

[Name] Set external drive device 1 pulse width

| | | | | | |
|--------|-------------|-----|-----|----|----|
| [Code] | ASCII | ESC | BEL | n1 | n2 |
| | Hexadecimal | 1B | 07 | n1 | n2 |
| | Decimal | 27 | 7 | n1 | n2 |

[Defined Area] Thermal : $1 \leq n1 \leq 127, 1 \leq n2 \leq 127$
 Slip : $1 \leq n1 \leq 127, 1 \leq n2 \leq 127$
 Validation : $1 \leq n1 \leq 127, 1 \leq n2 \leq 127$

[Initial Value] Thermal : n1 = 20 (Energizing time: 200 msec)
 n2 = 20 (Delay time: 200 msec)
 Slip : n1 = 20 (Energizing time: 200 msec)
 n2 = 20 (Delay time: 200 msec)
 Validation : n1 = 20 (Energizing time: 200 msec)
 n2 = 20 (Delay time: 200 msec)

[Function] Sets the energizing and delay times for drive of the external device.
 • Energizing time = 10 x n1 (ms)
 • Delay time = 10 x n2 (ms)

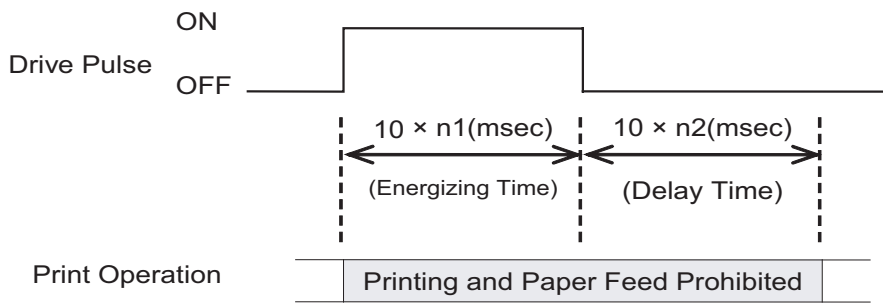

After printing, this is executed by BEL (External device 1 drive instruction) or FS (External device 1 drive instruction).

Handled in the following way when n1 and n2 are out of range.

- When n1 = 0, or n2 = 0, this command is ignored.
- When n1 > 127 is specified, n1 = 127; when n2 > 127 is specified, n2 = 127.

(Note) The settings using this command are valid for all stations and modes.

BEL

[Name] External device 1 drive instruction

[Code] ASCII BEL
 Hexadecimal 07
 Decimal 7

[Defined Area] Thermal : -
 Slip : -
 Validation : -

[Initial Value] Thermal : -
 Slip : -
 Validation : -

[Function] Executes the external device drive conditions set according to the command to set the external drive device pulse width (ESC BEL n1 n2).
 As with other commands, it temporarily stores data in the data buffer, then executes in the order received.

(Note) External device 1 and external device 2 cannot be executed simultaneously.

FS

[Name] External device 1 drive instruction

[Code] ASCII FS
 Hexadecimal 1C
 Decimal 28

[Defined Area] Thermal : -
 Slip : -
 Validation : -

[Initial Value] Thermal : -
 Slip : -
 Validation : -

[Function] Executes the external device drive conditions set according to the command to set the external drive device pulse width (ESC BEL n1 n2).
 As with other commands, it temporarily stores data in the data buffer, then executes in the order received.

(Note) External device 1 and external device 2 cannot be executed simultaneously.

SUB

[Name] External device 2 drive instruction
 [Code] ASCII SUB
 Hexadecimal 1A
 Decimal 26

[Defined Area] Thermal : -
 Slip : -
 Validation : -

[Initial Value] Thermal : -
 Slip : -
 Validation : -

[Function] Drives external device 2. The energizing time and delay time for the external device 2 are fixed at 200 ms each.
 As with other commands, it temporarily stores data in the data buffer, then executes in the order received.

(Note) External device 1 and external device 2 cannot be executed simultaneously.

EM

[Name] External device 2 drive instruction
 [Code] ASCII EM
 Hexadecimal 19
 Decimal 25

[Defined Area] Thermal : -
 Slip : -
 Validation : -

[Initial Value] Thermal : -
 Slip : -
 Validation : -

[Function] Drives external device 2. The energizing time and delay time for the external device 2 are fixed at 200 ms each.
 As with other commands, it temporarily stores data in the data buffer, then executes in the order received.

(Note) External device 1 and external device 2 cannot be executed simultaneously.

ESC GS BEL m t1 t2

[Name] Ring buzzer

| | | | | | | | |
|--------|-------------|-----|----|-----|---|----|----|
| [Code] | ASCII | ESC | GS | BEL | m | t1 | t2 |
| | Hexadecimal | 1B | 1D | 07 | m | t1 | t2 |
| | Decimal | 27 | 29 | 7 | m | t1 | t2 |

[Defined Area] Thermal : $1 \leq m \leq 2, 49 \leq m \leq 50$ ("1" $\leq m \leq$ "2")
 $1 \leq t1 \leq 255, 1 \leq t2 \leq 255$

Slip : $1 \leq m \leq 2, 49 \leq m \leq 50$ ("1" $\leq m \leq$ "2")
 $1 \leq t1 \leq 255, 1 \leq t2 \leq 255$

Validation : $1 \leq m \leq 2, 49 \leq m \leq 50$ ("1" $\leq m \leq$ "2")
 $1 \leq t1 \leq 255, 1 \leq t2 \leq 255$

[Initial Value] Thermal : -
 Slip : -
 Validation : -

[Function] Rings buzzer.
 m specifies the buzzer drive terminal.

| | |
|-------|-------------------------|
| m | Buzzer Drive Terminals |
| 1, 49 | Buzzer drive terminal 1 |
| 2, 50 | Buzzer drive terminal 2 |

t1 specifies the energizing time; t2 specifies the delay time.

- Energizing time = 20 msec x t1
- Delay time = 20 msec x t2

Buzzer cannot ring while printer is printing.

This command is prohibited for use for anything other than ringing the buzzer.

(When this command is used for the drawer drive on models equipped with an external device terminal, it will be damaged, so care is needed.)

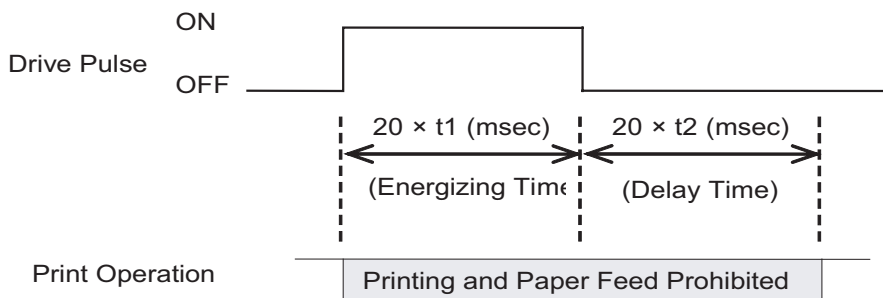

ESC GS EM DC2 m n1 n2

[Name] Execute external buzzer drive

| | | | | | | | | |
|--------|-------------|-----|----|----|-----|---|----|----|
| [Code] | ASCII | ESC | GS | EM | DC2 | m | n1 | n2 |
| | Hexadecimal | 1B | 1D | 19 | 12 | m | n1 | n2 |
| | Decimal | 27 | 29 | 25 | 18 | m | n1 | n2 |

[Defined Area] Thermal : $1 \leq m \leq 2, 49 \leq m \leq 50, ("1" \leq m \leq "2")$
 $1 \leq n1 \leq 20, n2 = 0$
 Slip : $1 \leq m \leq 2, 49 \leq m \leq 50, ("1" \leq m \leq "2")$
 $1 \leq n1 \leq 20, n2 = 0$
 Validation : $1 \leq m \leq 2, 49 \leq m \leq 50, ("1" \leq m \leq "2")$
 $1 \leq n1 \leq 20, n2 = 0$

[Initial Value] Thermal : -
 Slip : -
 Validation : -

[Function] Repeatedly drives the buzzer according to the ON/OFF conditions set by the external buzzer drive pulse condition command ESC GS EM DC1 m t1 t2.

m specifies the buzzer drive terminal to drive.

| m | Buzzer Drive Terminals |
|-------|-------------------------|
| 1, 49 | Buzzer drive terminal 1 |
| 2, 50 | Buzzer drive terminal 2 |

Specifies the number of times to repeat buzzer drive with $(n2 \times 256 + n1)$.

Buzzer cannot ring while printer is printing.

This command is prohibited for use for anything other than ringing the buzzer.

(When this command is used for the drawer drive on models equipped with an external device terminal, it will be damaged, so it is absolutely prohibited.))

The buzzer can be stopped by pressing the FEED switch or the RELEASE switch while the buzzer is ringing, or opening the receipt cover or the slip cover.

[Ex.:]

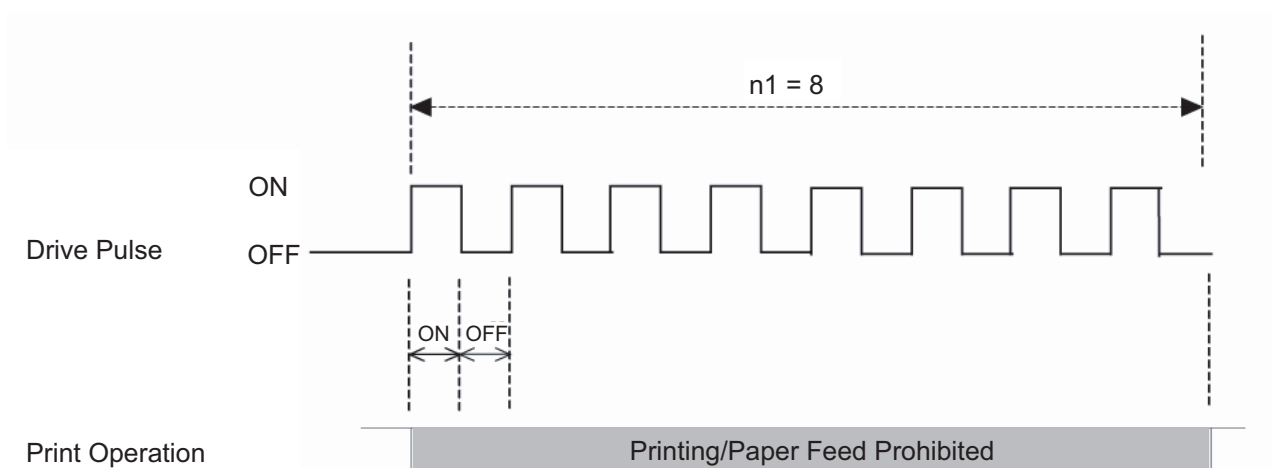

(Note) If the off time is set to 0 (zero), it is possible to ring the buzzer continuously for the amount of n1. For example, if on = 5 seconds, off = 0, and n1 = 20 times, the buzzer will ring for 100 seconds.

3-3-13) Print Settings

ESC RS d n

[Name] Set print density

| | | | | | |
|--------|-------------|-----|----|-----|---|
| [Code] | ASCII | ESC | RS | d | n |
| | Hexadecimal | 1B | 1E | 64 | n |
| | Decimal | 27 | 30 | 100 | n |

[Defined Area] Thermal : $0 \leq n \leq 15$
 $48 \leq n \leq 57$ ("0" $\leq n \leq$ "9"), $65 \leq n \leq 70$ ("A" $\leq n \leq$ "F")

Slip : -

Validation : -

[Initial Value] Thermal : Memory switch setting

Slip : -

Validation : -

[Function]

<Thermal>

Sets print density.

This command stops printing to be executed.

| n | Print Density |
|--------|-------------------|
| 0, 48 | Print density 1.3 |
| 1, 49 | Print density 1.2 |
| 2, 50 | Print density 1.1 |
| 3, 51 | Print density 1.0 |
| 4, 52 | Print density 0.9 |
| 5, 53 | Print density 0.8 |
| 6, 54 | Print density 0.7 |
| 7, 55 | (Reserved) |
| 8, 56 | (Reserved) |
| 9, 57 | (Reserved) |
| 10, 65 | (Reserved) |
| 11, 66 | (Reserved) |
| 12, 67 | (Reserved) |
| 13, 68 | (Reserved) |
| 14, 69 | (Reserved) |
| 15, 70 | (Reserved) |

<Slip>, <Validation>

Only setting is valid

Setting is valid after switching to thermal.

ESC RS r n

[Name] Set printing speed

| | | | | | |
|--------|-------------|-----|----|-----|---|
| [Code] | ASCII | ESC | RS | r | n |
| | Hexadecimal | 1B | 1E | 72 | n |
| | Decimal | 27 | 30 | 114 | n |

[Defined Area] Thermal : $0 \leq n \leq 2$
 $48 \leq n \leq 50$ ("0" $\leq n \leq$ "2")

Slip : -

Validation : -

[Initial Value] Thermal : Memory switch setting

Slip : -

Validation : -

[Function]

<Thermal>

Sets print speed.

This command stops printing to be executed.

| n | Print Speed |
|-------|-------------|
| 0, 48 | High speed |
| 1, 49 | Mid-speed |
| 2, 50 | Slow speed |

<Slip>, <Validation>

Only setting is valid

Setting is valid after switching to thermal.

3-3-14) Status

ESC RS a n

[Name] Set status transmission conditions

| | | | | | |
|--------|-------------|-----|----|----|---|
| [Code] | ASCII | ESC | RS | a | n |
| | Hexadecimal | 1B | 1E | 61 | n |
| | Decimal | 27 | 30 | 97 | n |

[Defined Area] Thermal : $0 \leq n \leq 3, 48 \leq n \leq 51, ("0" \leq n \leq "51")$
 Slip : $0 \leq n \leq 3, 48 \leq n \leq 51, ("0" \leq n \leq "51")$
 Validation : $0 \leq n \leq 3, 48 \leq n \leq 51, ("0" \leq n \leq "51")$

[Initial Value] Thermal : DIPS switches/Memory switch setting
 Slip : DIPS switches/Memory switch setting
 Validation : DIPS switches/Memory switch setting

[Function] Sets the status transmission conditions. See Appendix 2 for details regarding ASB status. This command is effective only on printers that have an interface capable of bi-directional data communications.

When using serial, parallel or USB (vendor class), use is possible.

The command is ignored (set to enable auto-status) when using Ethernet or wireless LAN.

Settings of this command are unaffected by the ESC @ (command initialization) command.

See each printer's product specifications manual for details on the memory switch settings.

(Note) The settings using this command are valid for all stations and modes.

ESC ACK SOH

[Name] Real-time printer status (ASB Status)

| | | | | |
|--------|-------------|-----|-----|-----|
| [Code] | ASCII | ESC | ACK | SOH |
| | Hexadecimal | 1B | 06 | 01 |
| | Decimal | 27 | 6 | 1 |

[Defined Area] Thermal : -
Slip : -
Validation : -

[Initial Value] Thermal : -
Slip : -
Validation : -

[Function] This command is effective only when using an interface capable of bi-directional data communications.
When this command is received, the printer sends the status to the host in real time. Immediately executed not when taking out from the reception buffer, but when received from the host.)
Bi-directional parallel interfaces enter a “data present” state.
See the Appendix Auto Status for details regarding status.
When in the serial interface DTR mode, and using a parallel interface, set so that the status can be inquired even when offline for errors, etc.
This command is not used when auto-status is valid.
When this command is sent once to the printer, do not send the next ESC ACK SOH command until the final auto status has been received.

See Appendix 2 Automatic Status for details regarding ASB status.

ENQ

[Name] Real-time printer status (1)

| | | |
|--------|-------------|-----|
| [Code] | ASCII | ENQ |
| | Hexadecimal | 05 |
| | Decimal | 5 |

[Defined Area] Thermal : -
Slip : -
Validation : -

[Initial Value] Thermal : -
Slip : -
Validation : -

[Function] This command is effective only when using an interface capable of bi-directional data communications.
When this command is received, the printer sends one byte of ENQ status to the host in real time. Immediately executed not when taking out from the reception buffer, but when received from the host.)
Bi-directional parallel interfaces enter a “data present” state.
See Appendix ENQ Command Status for details regarding status.
When this command is sent once to the printer, do not send the next ENQ command until the ENQ status has been received.
This command is not used when auto-status is valid.

See Appendix 2 ENQ Command Status for details regarding status.

EOT

[Name] Real-time printer status (2)
 [Code] ASCII EOT
 Hexadecimal 04
 Decimal 4

[Defined Area] Thermal : -
 Slip : -
 Validation : -
 [Initial Value] Thermal : -
 Slip : -
 Validation : -

[Function] This command is effective only when using an interface capable of bi-directional data communications.
 When this command is received, the printer sends one byte of EOT status to the host in real time. Immediately executed not when taking out from the reception buffer, but when received from the host.)
 Bi-directional parallel interfaces enter a “data present” state.
 See Appendix EOT Command Status for details regarding status.
 When this command is sent once to the printer, do not send the next EOT command until the EOT status has been received.
 This command is not used when auto-status is valid.

See Appendix 2 EOT Command Status for details regarding status.

ETB

[Name] Update of ETB status of ASB
 [Code] ASCII ETB
 Hexadecimal 17
 Decimal 23

[Defined Area] Thermal : -
 Slip : -
 Validation : -
 [Initial Value] Thermal : -
 Slip : -
 Validation : -

[Function] This command is effective only when using an interface capable of bi-directional data communications.
 This command waits until all printing is completed (the print motor is stopped), and after printing is completed, the auto status printer status 1-1 (ETB command) becomes 1 (ETB execution completed), and the ETB counter is updated (incremented).
 Note that when executing this command, and print data remains the line buffer, this command is executed after printing the remaining data.
 The hose checks that this bit has changed to “1” thereby making it possible to ascertain that the printing of the sent data is completed.
 This ETB status bit is cleared to “0” when returned to host.
 Also, ETB is appended to the end of 1 data block and several blocks are sent at once. By getting the ETB counter sequentially, it is possible to confirm the end of printing the several blocks.
 Note that the ETB counter is cleared to zero by the ESC RS E command.

The following shows the details of the processing in the printer with this command.

- (1) Reads out the ETB command from the reception buffer.
- (2) Waits for the printing of data to be completed before the ETB command
- (3) After checking the end of printing, the auto status ETB status is set, and the ETB counter is incremented.
- (4) Auto status transmission (only when auto status is valid)

See Appendix 2 for details regarding the ASB status.

ESC RS E n

[Name] Initialize ASB ETB counter, and ETB status.

| | | | | | |
|--------|-------------|-----|----|----|---|
| [Code] | ASCII | ESC | RS | E | n |
| | Hexadecimal | 1B | 1E | 45 | n |
| | Decimal | 27 | 30 | 69 | n |

| | | | |
|----------------|------------|---|-----------------|
| [Defined Area] | Thermal | : | n = 0, 48 ("0") |
| | Slip | : | n = 0, 48 ("0") |
| | Validation | : | n = 0, 48 ("0") |

| | | | |
|-----------------|------------|---|---------------------|
| [Initial Value] | Thermal | : | ASB ETB counter = 0 |
| | Slip | : | ASB ETB counter = 0 |
| | Validation | : | ASB ETB counter = 0 |

[Function]

Clears the ASB ETB counter to zero and clears the ETB status. However, when clearing the ETB counter to zero using this command, ASB status is not transmitted. The ETB counter and ETB status are initialized by the following command in addition to this command.

- Cancel print data and initialize commands <CAN>

3-3-15) Kanji Characters

ESC p

[Name] Specify JIS Kanji character mode

| | | | |
|--------|-------------|-----|-----|
| [Code] | ASCII | ESC | p |
| | Hexadecimal | 1B | 70 |
| | Decimal | 27 | 112 |

[Defined Area] Thermal : -
Slip : -
Validation : -

[Initial Value] Thermal : Cancel JIS Kanji character mode
Slip : Cancel JIS Kanji character mode
Validation : Cancel JIS Kanji character mode

[Function] Specifies JIS Kanji character mode
When in JIS Kanji character mode, all character codes are handled as 2 byte Japanese characters (First byte: upper code; second byte: lower code).
Even when setting the JIS Kanji mode, the control code is valid.
This command is ignored for models not equipped with Japanese and Kanji characters and when the specification for the location of use is specified as SBCS (single byte countries) by the memory switch.

<Slip>, <Validation>

When page mode is selected, only setting is valid
Setting is valid after switching to line mode.

(Note) The settings by this command are valid for all stations.

ESC q

[Name] Cancel JIS Kanji character mode

| | | | |
|--------|-------------|-----|-----|
| [Code] | ASCII | ESC | q |
| | Hexadecimal | 1B | 71 |
| | Decimal | 27 | 113 |

[Defined Area] Thermal : -
Slip : -
Validation : -

[Initial Value] Thermal : Cancel JIS Kanji character mode
Slip : Cancel JIS Kanji character mode
Validation : Cancel JIS Kanji character mode

[Function] Cancels JIS Kanji character mode.
This command is ignored for models not equipped with Japanese and Kanji characters and when the specification for the location of use is specified as SBCS (single byte countries) by the memory switch.

<Slip>, <Validation>

When page mode is selected, only setting is valid
Setting is valid after switching to line mode.

(Note) The settings by this command are valid for all stations.

ESC \$ n

[Name] Specify/cancel JIS Kanji character mode

[Code] ASCII ESC \$ n
 Hexadecimal 1B 24 n
 Decimal 27 36 n

[Defined Area] Thermal : n = 0, 1, 48, 49
 Slip : n = 0, 1, 48, 49
 Validation : n = 0, 1, 48, 49

[Initial Value] Thermal : Memory switch setting
 Slip : Memory switch setting
 Validation : Memory switch setting

[Function] Specifies and cancels the shift JIS Kanji character mode.

| n | Shift JIS Japanese Character Mode |
|-------|--|
| 0, 48 | Cancel shift JIS Kanji character mode |
| 1, 49 | Specify shift JIS Kanji character mode |

When in shift JIS Kanji character mode, if the data is <80>H to <9F>H or <E0>H to <FF>H, this is handled as 2 byte Japanese characters (First byte: upper code; second byte: lower code).

Even when setting the shift JIS Kanji character mode, the control code is valid.

When the shift JIS Kanji character mode is canceled, the block graphics mode is selected. At that time, if the data is <80>H to <9F>H or <E0>H to <FF>H, this is handled as 1 byte of block graphic characters.

This command is ignored for models not equipped with Japanese and Kanji characters and when the specification for the location of use is specified as SBCS (single byte countries) by the memory switch.

See each printer's product specifications manual for details on the memory switch settings.

When the lower code is <7F>, <FD> to <FF>h, two bytes are ignored.

<Slip>, <Validation>

When page mode is selected, only setting is valid

Setting is valid after switching to line mode.

(Note) The settings by this command are valid for all stations.

ESC s n1 n2

[Name] Set two-byte Kanji characters left/right spaces

| | | | | | |
|--------|-------------|-----|-----|----|----|
| [Code] | ASCII | ESC | s | n1 | n2 |
| | Hexadecimal | 1B | 73 | n1 | n2 |
| | Decimal | 27 | 115 | n1 | n2 |

| | | | | | |
|-----------------|------------|------|---|---|--|
| [Defined Area] | Thermal | : | 0 ≤ n1 ≤ 7, 48 ≤ n1 ≤ 55 ("0" ≤ n1 ≤ "7") | | |
| | | | 0 ≤ n2 ≤ 15, 48 ≤ n2 ≤ 57 ("0" ≤ n2 ≤ "9"), 65 ≤ n2 ≤ 70 ("A" ≤ n2 ≤ "F") | | |
| | | Slip | : | 0 ≤ n1 ≤ 7, 48 ≤ n1 ≤ 55 ("0" ≤ n1 ≤ "7") | |
| | | | 0 ≤ n2 ≤ 15, 48 ≤ n2 ≤ 57 ("0" ≤ n2 ≤ "9"), 65 ≤ n2 ≤ 70 ("A" ≤ n2 ≤ "F") | | |
| [Initial Value] | Thermal | : | Memory switch setting | | |
| | | Slip | : | Memory switch setting | |
| | Validation | : | Memory switch setting | | |

[Function] Adds n1 dot left space and n2 dot right space to Kanji characters.
 This command is ignored for models not equipped with Chinese fonts (for overseas) and when the specification for the location of use is specified as SBCS (single byte countries) by the memory switch.
 See each printer's product specifications manual for details on the memory switch settings.

<Slip>, <Validation>

The values of n1 and n2 when using two-byte 8 x 16, two-byte 16 x 16 and double-tall 8 x 16 characters correspond to the n1 and n2 values for double high/double wide 16 x 16 characters.
 If the Japanese character size including the right and left spaces (n1 + character width + n2) exceeds the print region, printing will not be possible and a question mark (" ") will be printed instead.
 When page mode is selected, only setting is valid
 Setting is valid after switching to line mode.

(Note) The settings by this command are valid for all stations.

ESC t n1 n2

[Name] Set single-byte Kanji characters left/right spaces

| | | | | | |
|--------|-------------|-----|-----|----|----|
| [Code] | ASCII | ESC | t | n1 | n2 |
| | Hexadecimal | 1B | 74 | n1 | n2 |
| | Decimal | 27 | 116 | n1 | n2 |

[Defined Area] Thermal : $0 \leq n1 \leq 7$, $48 \leq n1 \leq 55$ ("0" \leq n1 \leq "7")
 $0 \leq n2 \leq 15$, $48 \leq n2 \leq 57$ ("0" \leq n2 \leq "9"), $65 \leq n2 \leq 70$ ("A" \leq n2 \leq "F")
 Slip : $0 \leq n1 \leq 7$, $48 \leq n1 \leq 55$ ("0" \leq n1 \leq "7")
 $0 \leq n2 \leq 15$, $48 \leq n2 \leq 57$ ("0" \leq n2 \leq "9"), $65 \leq n2 \leq 70$ ("A" \leq n2 \leq "F")
 Validation : $0 \leq n1 \leq 7$, $48 \leq n1 \leq 55$ ("0" \leq n1 \leq "7")
 $0 \leq n2 \leq 15$, $48 \leq n2 \leq 57$ ("0" \leq n2 \leq "9"), $65 \leq n2 \leq 70$ ("A" \leq n2 \leq "F")

[Initial Value] Thermal : Memory switch setting
 Slip : Memory switch setting
 Validation : Memory switch setting

[Function] Adds n1 dot left space and n2 dot right space to single-byte Kanji characters.
 See each printer's product specifications manual for details on the memory switch settings.
 This command is ignored for models not equipped with Japanese and Kanji characters and when the specification for the location of use is specified as SBCS (single byte countries) by the memory switch.

<Slip>, <Validation>

The values of n1 and n2 when using two-byte 8 x 16, two-byte 16 x 16 and double-tall 8 x 16 characters correspond to the n1 and n2 values for double high/double wide 16 x 16 characters.
 If the Japanese character size including the right and left spaces (n1 + character width + n2) exceeds the print region, printing will not be possible and a question mark (" ") will be printed instead.
 When page mode is selected, only setting is valid
 Setting is valid after switching to line mode.

(Note) The settings by this command are valid for all stations.

ESC r c1 c2 d1 ... dk

[Name] Register Chinese download characters

| | | | | | | | | |
|--------|-------------|-----|-----|----|----|----|----|----|
| [Code] | ASCII | ESC | r | c1 | c2 | d1 | .. | dk |
| | Hexadecimal | 1B | 72 | c1 | c2 | d1 | .. | dk |
| | Decimal | 27 | 114 | c1 | c2 | d1 | .. | dk |

- [Defined Area] Thermal : $0 \leq d \leq 255$
 $k = 72$, c1 and c2 differ according to specifications and code type (see table below).
 Slip : $0 \leq d \leq 255$
 $k = 32$, c1 and c2 differ according to specifications and code type (see table below).
 Validation : $0 \leq d \leq 255$
 $k = 32$, c1 and c2 differ according to specifications and code type (see table below).
- [Initial Value] Thermal : All spaces
 Slip : All spaces
 Validation : All spaces

[Function] Registers Chinese download characters to c1 and c2 addresses. Those already registered to these addresses are overwritten.
 If c1 and c2 are outside of the defined are or the printer is model not equipped with Chinese fonts (for overseas) and when the specification for the location of use is specified as SBCS (single byte countries) by the memory switch, the printer discards up to d1 and dk.
 Chinese download characters once defined are valid until redefined or the power is turned OFF.
 Defined Chinese download characters are accessed with two-bytes, in the same way as other Kanji characters. At that time, c1 is the first byte, c2 is the second byte. d1, d2 ... d32 are character data.

<Thermal>

The defined ranges are shown below. (* The registration region is the same for Japanese characters in JIS or shift JIS.)

| Specifications | c1 | c2 | Registration count |
|------------------------------------|----------|--|--------------------|
| Japanese characters/JIS type | c1 = 77h | $21h \leq c2 \leq 7Eh$ | 94 Characters |
| Japanese characters/Shift JIS type | c1 = ECh | $40h \leq c2 \leq 7Eh$ $80h \leq c2 \leq 9Eh$ | 94 Characters |

They are designed as shown below and data is sent sequentially.

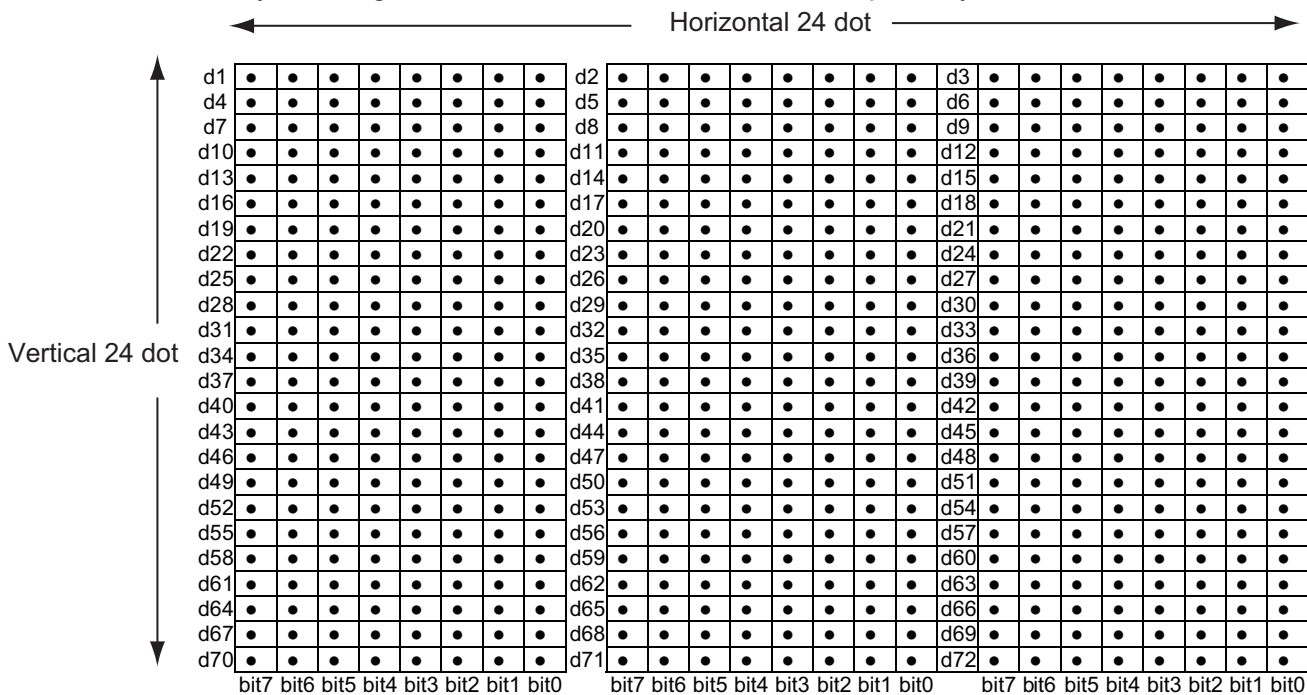

● : Font Data / ○ : Invalid Data

<Slip>, <Validation>

The defined ranges are shown below.

| Specifications | c1 | c2 | Registration count |
|------------------------------------|----------|----------------|--------------------|
| Japanese Language Kanji characters | c1 = 77h | 21h ≤ c2 ≤ 7Eh | 94 Characters |

They are designed as shown below and data is sent sequentially.

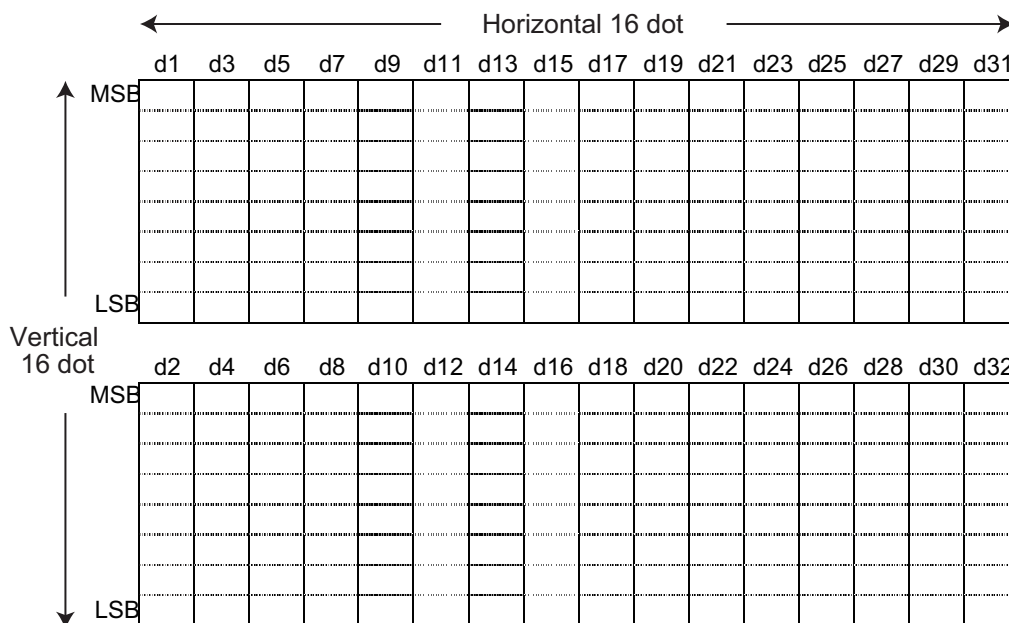

The font of Kanji download characters is composed of 16 x 16 dot patterns.

Bits that correspond to the dots to print are "1," and the bits that correspond to the dots that are not printed are "0."

When page mode is selected, only registration is possible.

Printing is possible after switching to line mode.

Registered data is shared by slip and validation.

ESC u n

[Name] Specify two-byte 16 x 16 dot Kanji character (Single density/double density)

| | | | | |
|--------|-------------|-----|-----|---|
| [Code] | ASCII | ESC | u | n |
| | Hexadecimal | 1B | 75 | n |
| | Decimal | 27 | 117 | n |

[Defined Area] Thermal : -
 Slip : n = 0, 1, n = 48, 49 ("0," "1")
 Validation : n = 0, 1, n = 48, 49 ("0," "1")

[Initial Value] Thermal : -
 Slip : Specify two-byte 16 x 16 dot Kanji characters (single density).
 Validation : Specify two-byte 16 x 16 dot Kanji characters (single density).

[Function]
 <Thermal>

Only setting is valid
 Setting is valid after switching to slip or validation.

<Slip>, <Validation>

Specifies two-byte 16 x 16 dot Kanji character (Single density/double density) (* : See "Relationship of Japanese Character Size Selection."

| n | State Transition |
|-------|---|
| 0, 48 | Specify two-byte 16 x 16 dot [double density] Japanese characters When two-bytes is selected, they become four-pass characters (state (A) to state (B)) Dots continuous horizontally are printing. Sets to the 4 x expanded character mode by combining with ESC x 0 (Specify expanded Japanese characters) (state (A) → state (D)) |
| 1, 49 | Specify two-byte 16 x 16 dot Kanji characters (single density). When two-bytes is selected, they become two-pass characters (state (B) to state (A)) Dots continuous horizontally are thinned for printing. Sets to the vertical expanded character mode by combining with ESC x 0 (Specify expanded Kanji characters) (state (B) → state (C)) |

When page mode is selected, only setting is valid
 Setting is valid after switching to line mode.

ESC x n

[Name] Specify expanded Kanji characters (Double tall/double high & wide)

| | | | | |
|--------|-------------|-----|-----|---|
| [Code] | ASCII | ESC | x | n |
| | Hexadecimal | 1B | 78 | n |
| | Decimal | 27 | 120 | n |

[Defined Area] Thermal : -
 Slip : n = 0, 1, n = 48, 49 ("0," "1")
 Validation : n = 0, 1, n = 48, 49 ("0," "1")

[Initial Value] Thermal : -
 Slip : Specify two-byte 16 x 16 dot Kanji characters (single density).
 Validation : Specify two-byte 16 x 16 dot Kanji characters (single density).

[Function]

<Thermal>

Only setting is valid
 Setting is valid after switching to slip or validation.

<Slip>, <Validation>

Sets (double tall/double high and wide) Kanji character expansion. (* : See "Relationship of Japanese Character Size Selection.")

| n | State Transition |
|-------|--|
| 0, 48 | Sets Kanji character expansion. When 16 x 16 dot Kanji characters [single density] are selected, they expand only in the vertical direction. [Vertical tall size: State (A) to state (C)] When 16 x 16 dot Kanji characters [double density] are selected, they expand both vertically and horizontally. [Double high and wide size: State (B) to state (D)] |
| 1, 49 | Cancels specify Kanji character expansion, and sets to two-byte Kanji characters When 16 x 16 dot Kanji characters [double density] are selected, they become two-pass characters (state (C) to state (A)) When 16 x 16 dot Kanji characters [double density] are selected, they become four-pass characters (state (D) to state (B)) |

When page mode is selected, only setting is valid
 Setting is valid after switching to line mode.

ESC w n

[Name] Specify expanded Kanji characters (batch double tall/double high & wide)

[Code] ASCII ESC w n
 Hexadecimal 1B 77 n
 Decimal 27 119 n

[Defined Area] Thermal : -
 Slip : n = 0, 1, n = 48, 49 ("0," "1")
 Validation : n = 0, 1, n = 48, 49 ("0," "1")

[Initial Value] Thermal : -
 Slip : Specify two-byte 16 x 16 dot Kanji characters (single density).
 Validation : Specify two-byte 16 x 16 dot Kanji characters (single density).

[Function]
 <Thermal>

Only setting is valid
 Setting is valid after switching to slip or validation.

<Slip>, <Validation>

Sets (batch double tall/double high and wide) Kanji character expansion. (* : See "Relationship of Japanese Character Size Selection.")

| n | State Transition |
|-------|---|
| 0, 48 | Sets double high & wide (double-wide/double-high) 16 x 16 Japanese characters. (to state (D)) |
| 1, 49 | Cancels specify Japanese character expansion, and sets to two-byte 16 x 16 dot Japanese characters [single density] Japanese characters become two-pass characters (to state (A)) |

When page mode is selected, only setting is valid
 Setting is valid after switching to line mode.

<Relationship of Kanji character Size Selection>

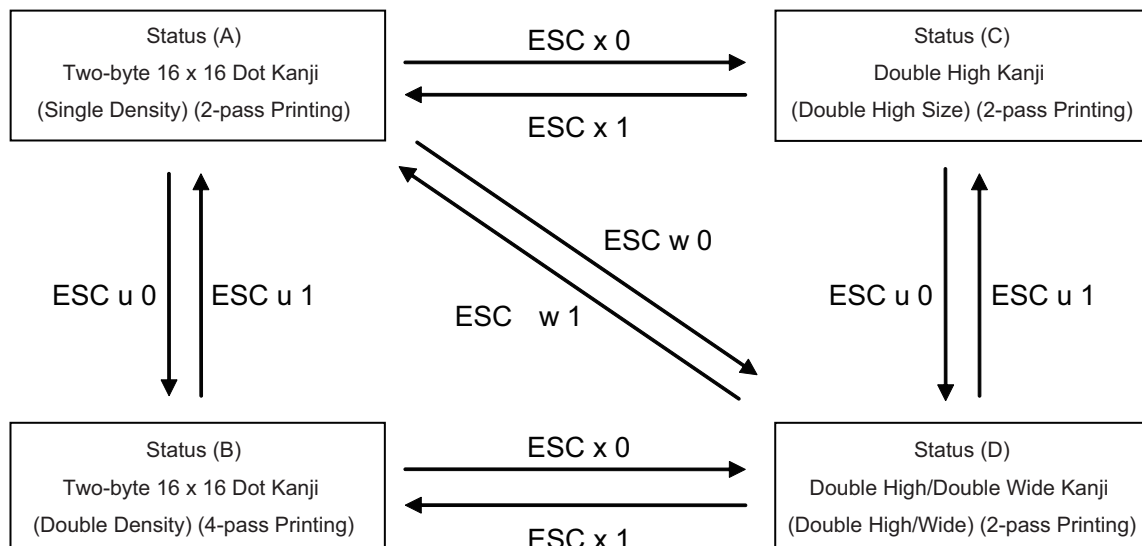

See 5. Appendix 5-2 Expansion Position for details on the differences of dot configurations of [single density] and [double density] in two-byte 16 x 16 dot Japanese characters. This section use a Japanese character to illustrate the difference.

3-3-16) Others

RS

[Name] Ring buzzer
 [Code] ASCII RS
 Hexadecimal 1E
 Decimal 30

[Defined Area] Thermal : -
 Slip : -
 Validation : -
 [Initial Value] Thermal : -
 Slip : -
 Validation : -

[Function] Issues a short buzzer sound from the printer.
 Execute this command after printing the unprinted data in the line buffer.

CAN

[Name] Cancel print data and initialize commands
 [Code] ASCII CAN
 Hexadecimal 18
 Decimal 24

[Defined Area] Thermal : -
 Slip : -
 Validation : -
 [Initial Value] Thermal : -
 Slip : -
 Validation : -

[Function] When the reception buffer and line buffer are cleared, the set commands are initialized.
 Immediately executed not when taking out from the reception buffer, but when received from the host.
 DIPSW re-loading is not performed.
 After execution, thermal is selected.

The following shows the specifications that are not initialized by this command.

- Set print density
- Set print speed
- Two Color Printing Mode Setting
- Printing color in 2-color printing mode
- External device drive condition
- Auto status valid/invalid conditions

ESC @

[Name] Command initialization

| | | | |
|--------|-------------|-----|----|
| [Code] | ASCII | ESC | @ |
| | Hexadecimal | 1B | 40 |
| | Decimal | 27 | 64 |

[Defined Area] Thermal : -
Slip : -
Validation : -

[Initial Value] Thermal : -
Slip : -
Validation : -

[Function] Initializes each command after printing data in the line buffer.
However, printers with memory switch settings are initialized to the memory switch settings.
DIPSW re-loading is not performed.
After execution, thermal is selected.

<Shared>

- ANK characters, Kanji character adornment, expansion
- Kanji character mode
- ANK right space
- Kanji character right and left spaces
- Character pitch
- International characters
- Code pages
- Set slash zero
- Set specify/cancel external character (external register character data is retained)
- Line feed amount
- Set upside-down, position alignment
- Right/left margins
- Horizontal tab

<Thermal>

- Page length
- Current position (move to top of page, top of line)
- Vertical tab

<Slip>, <Validation>

- Paper discharge

<Other Information>

The following shows the specifications that are not initialized by this command.

- Set print density
- Set print speed
- Two Color Printing Mode Setting
- Printing color in 2-color printing mode
- External device drive condition
- Auto status valid/invalid conditions

ESC U n

[Name] Select printing direction

| | | | | |
|--------|-------------|-----|----|---|
| [Code] | ASCII | ESC | U | n |
| | Hexadecimal | 1B | 55 | n |
| | Decimal | 27 | 85 | n |

[Defined Area] Thermal : -
 Slip : $0 \leq n \leq 2, 48 \leq n \leq 50, ("0" \leq n \leq "2")$
 Validation : $0 \leq n \leq 2, 48 \leq n \leq 50, ("0" \leq n \leq "2")$

[Initial Value] Thermal : -
 Slip : n = 0
 Validation : n = 0

[Function]

<Thermal>

Only setting is valid
 Setting is valid after switching to slip or validation.

<Slip>, <Validation>

Executes print direction specified by this command after printing data in the line buffer.

| n | State Transition |
|-------|----------------------------------|
| 0, 48 | Specify bi-directional printing |
| 1, 49 | Specify uni-directional printing |

Bi-directional printing is faster than uni-directional printing.
 With uni-directional printing, printing is performed only when the print head moves from left to right.
 The printing direction can be set independently for both line mode and page mode.
 Setting values are shared for slip, and validation line mode and page mode is selected.

ESC GS # m N n1 n2 n3 n4 LF NUL

[Name] Set memory switch

| | | | | | | | | | | | | |
|--------|-------------|-----|----|----|---|---|----|----|----|----|----|-----|
| [Code] | ASCII | ESC | GS | # | m | N | n1 | n2 | n3 | n4 | LF | NUL |
| | Hexadecimal | 1B | 1D | 23 | m | N | n1 | n2 | n3 | n4 | 0A | 00 |
| | Decimal | 27 | 29 | 35 | m | N | n1 | n2 | n3 | n4 | 10 | 0 |

[Defined Area] Thermal : m = 87, 84, 44, 43, 45, 64, 75, 76 (m = "W", "T", ",", "+", "-", "@", "K", "L")
 $48 \leq n1 \leq 57$ ("0" \leq n1 \leq "9"), $65 \leq n1 \leq 70$ ("A" \leq n1 \leq "F"), $97 \leq n1 \leq 102$ ("a" \leq n1 \leq "f")
 $48 \leq n2 \leq 57$ ("0" \leq n2 \leq "9"), $65 \leq n2 \leq 70$ ("A" \leq n2 \leq "F"), $97 \leq n2 \leq 102$ ("a" \leq n2 \leq "f")
 $48 \leq n3 \leq 57$ ("0" \leq n3 \leq "9"), $65 \leq n3 \leq 70$ ("A" \leq n3 \leq "F"), $97 \leq n3 \leq 102$ ("a" \leq n3 \leq "f")
 $48 \leq n4 \leq 57$ ("0" \leq n4 \leq "9"), $65 \leq n4 \leq 70$ ("A" \leq n4 \leq "F"), $97 \leq n4 \leq 102$ ("a" \leq n4 \leq "f")
 $48 \leq N \leq 57$ ("0" \leq N \leq "9"), $65 \leq N \leq 72$ ("A" \leq N \leq "F"), $97 \leq N \leq 104$ ("a" \leq N \leq "h")
 N = 85 (U) User defined region

Slip : m = 87, 84, 44, 43, 45, 64, 75, 76 (m = "W", "T", ",", "+", "-", "@", "K", "L")
 $48 \leq n1 \leq 57$ ("0" \leq n1 \leq "9"), $65 \leq n1 \leq 70$ ("A" \leq n1 \leq "F"), $97 \leq n1 \leq 102$ ("a" \leq n1 \leq "f")
 $48 \leq n2 \leq 57$ ("0" \leq n2 \leq "9"), $65 \leq n2 \leq 70$ ("A" \leq n2 \leq "F"), $97 \leq n2 \leq 102$ ("a" \leq n2 \leq "f")
 $48 \leq n3 \leq 57$ ("0" \leq n3 \leq "9"), $65 \leq n3 \leq 70$ ("A" \leq n3 \leq "F"), $97 \leq n3 \leq 102$ ("a" \leq n3 \leq "f")
 $48 \leq n4 \leq 57$ ("0" \leq n4 \leq "9"), $65 \leq n4 \leq 70$ ("A" \leq n4 \leq "F"), $97 \leq n4 \leq 102$ ("a" \leq n4 \leq "f")
 $48 \leq N \leq 57$ ("0" \leq N \leq "9"), $65 \leq N \leq 72$ ("A" \leq N \leq "F"), $97 \leq N \leq 104$ ("a" \leq N \leq "h")
 N = 85 (U) User defined region

Validation : m = 87, 84, 44, 43, 45, 64, 75, 76 (m = "W", "T", ",", "+", "-", "@", "K", "L")
 $48 \leq n1 \leq 57$ ("0" \leq n1 \leq "9"), $65 \leq n1 \leq 70$ ("A" \leq n1 \leq "F"), $97 \leq n1 \leq 102$ ("a" \leq n1 \leq "f")
 $48 \leq n2 \leq 57$ ("0" \leq n2 \leq "9"), $65 \leq n2 \leq 70$ ("A" \leq n2 \leq "F"), $97 \leq n2 \leq 102$ ("a" \leq n2 \leq "f")
 $48 \leq n3 \leq 57$ ("0" \leq n3 \leq "9"), $65 \leq n3 \leq 70$ ("A" \leq n3 \leq "F"), $97 \leq n3 \leq 102$ ("a" \leq n3 \leq "f")
 $48 \leq n4 \leq 57$ ("0" \leq n4 \leq "9"), $65 \leq n4 \leq 70$ ("A" \leq n4 \leq "F"), $97 \leq n4 \leq 102$ ("a" \leq n4 \leq "f")
 $48 \leq N \leq 57$ ("0" \leq N \leq "9"), $65 \leq N \leq 72$ ("A" \leq N \leq "F"), $97 \leq N \leq 104$ ("a" \leq N \leq "h")
 N = 85 (U) User defined region

[Initial Value] Thermal : -
 Slip : -
 Validation : -

[Function] Sends command to write after defining memory switch using the definition command specified by the following classes.
 Memory switch information defined by the command to write is written to the volatile memory.
 When writing to the volatile memory by the command to write, the printer executes a reset.
 By specifying N = 85 ("U"), it is possible to register any 16 bit data.

| Function | Class | m | N | n1 n2 n3 n4 |
|--|------------|-----|--------------|-----------------|
| Definition data write and reset | Write | "W" | Fixed at "0" | Fixed at "0000" |
| Definition data write and reset and test print | Write | "T" | Fixed at "0" | Fixed at "0000" |
| Data Definition (Data Specification) | Definition | "," | N | n1 n2 n3 n4 |
| Data definition (set specified bit) | Definition | "+" | N | n1 n2 n3 n4 |
| Data definition (clear specified bit) | Definition | "-" | N | n1 n2 n3 n4 |
| Data Definition (initialize all data) | Definition | "@" | Fixed at "0" | Fixed at "0000" |
| Definition data write, reset, test print, and dot adjustment | | | | |
| Definition data write, dot adjustment, test print, and reset | | | | |

- m : Mode Selection
- N : Memory switch number to specify
- n1 n2 n3 n4 : Specified data m = "+" → Specified Data
 m = "+" → Bit number to set
 m = "-" → Bit number to clear

<Thermal>

When a function was specified that accompanies position adjustment (m = "K", "L"), this executes only defined data write & reset, but does not execute the position adjustment.

<Validation>

When a function was specified that accompanies a self-print, and position adjustment (m = "T", "K", "L"), this executes only defined data write & reset, but does not execute the self-print or position adjustment.

ESC # @ LF NUL

[Name] Initialize all memory switches

| [Code] | ASCII | ESC | # | @ | LF | NUL |
|--------|-------------|-----|----|----|----|-----|
| | Hexadecimal | 1B | 23 | 40 | 0A | 00 |
| | Decimal | 27 | 35 | 64 | 10 | 0 |

[Defined Area] Thermal : -
Slip : -
Validation : -

[Initial Value] Thermal : -
Slip : -
Validation : -

[Function] Initializes all memory switches
Valid when power turned on again, or a reset is applied

ESC # N ? n1 n2 n3 n4 LF NUL

[Name] Enquire memory switch settings

| [Code] | ASCII | ESC | # | N | ? | n1 | n2 | n3 | n4 | LF | NUL |
|--------|-------------|-----|----|---|----|----|----|----|----|----|-----|
| | Hexadecimal | 1B | 23 | N | 3F | n1 | n2 | n3 | n4 | 0A | 00 |
| | Decimal | 27 | 35 | N | 63 | n1 | n2 | n3 | n4 | 10 | 0 |

[Defined Area] Thermal : n1 = 48 ("0"), n2 = 48 ("0"), n3 = 48 ("0"), n4 = 48 ("0")
48 ≤ N ≤ 57 ("0" ≤ N ≤ "9"), 65 ≤ N ≤ 72 ("A" ≤ N ≤ "F"), 97 ≤ N ≤ 104 ("a" ≤ N ≤ "h")
N = 85 (U) User defined region
Slip : n1 = 48 ("0"), n2 = 48 ("0"), n3 = 48 ("0"), n4 = 48 ("0")
48 ≤ N ≤ 57 ("0" ≤ N ≤ "9"), 65 ≤ N ≤ 72 ("A" ≤ N ≤ "H"), 97 ≤ N ≤ 104 ("a" ≤ N ≤ "h")
N = 85 (U) User defined region
Validation : n1 = 48 ("0"), n2 = 48 ("0"), n3 = 48 ("0"), n4 = 48 ("0")
48 ≤ N ≤ 57 ("0" ≤ N ≤ "9"), 65 ≤ N ≤ 72 ("A" ≤ N ≤ "H"), 97 ≤ N ≤ 104 ("a" ≤ N ≤ "h")
N = 85 (U) User defined region

[Initial Value] Thermal : -
Slip : -
Validation : -

[Function] Sends the memory switch settings.
By specifying N = 85 ("U"), it is possible to read out any user-registered 16 bit data.

- N: Memory Switch Number

Transmission Format
ESC # N ? d1 d2 d3 d4 LF NUL

- N: Memory number
- d1, d2, d3, d4: Memory switch settings

ESC # * LF NUL

[Name] Inquire printer version
 [Code] ASCII ESC # * LF NUL
 Hexadecimal 1B 23 2A 0A 00
 Decimal 27 35 42 10 0

[Defined Area] Thermal : -
 Slip : -
 Validation : -
 [Initial Value] Thermal : -
 Slip : -
 Validation : -

[Function] Sends printer version.
 ESC # *, printer version LF NUL
 < Ex: For HSP7000 Ver. 1.0 ESC # *, HSP7000 Ver. 1.0 LF NUL >

ESC ? LF NUL

[Name] Reset printer (execute self print)
 [Code] ASCII ESC ? LF NUL
 Hexadecimal 1B 3F 0A 00
 Decimal 27 63 10 0

[Defined Area] Thermal : -
 Slip : -
 Validation : -
 [Initial Value] Thermal : -
 Slip : -
 Validation : -

[Function] Hardware resets the printer and executes on self print.
 After sending this command, the next data is not sent until the printer is online (in a state wherein it
 can receive data).
 When resetting the printer, the following processes are performed.

| I/F | Mode | Process |
|----------|---------------|-----------------|
| Parallel | --- | BUSY output |
| RS-232C | DTR mode | DTR mark output |
| | Xon/Xoff Mode | Xoff output |

<Validation> Executes only a reset; does not execute a self-print.

DC3

[Name] Printer deselect

[Code] ASCII DC3
 Hexadecimal 13
 Decimal 19

[Defined Area] Thermal : -
 Slip : -
 Validation : -

[Initial Value] Thermal : Select printer
 Slip : Select printer
 Validation : Select printer

[Function] Deselects printer.
 All received data is discarded until the next DC1 (printer select) is received.

DC1

[Name] Select printer

[Code] ASCII DC1
 Hexadecimal 11
 Decimal 17

[Defined Area] Thermal : -
 Slip : -
 Validation : -

[Initial Value] Thermal : Select printer
 Slip : Select printer
 Validation : Select printer

[Function] This cancels the deselect state of the DC3 (printer deselect) and selects the printer.

3-4) Raster Graphics Command Details

Raster graphics are command types and incidental specifications that enable high speed and high quality printing of graphics.

The following shows the characteristics and specifications for raster graphics.

- Define the raster mode command as an expansion set for Star Line mode.
Basically no restrictions set for use of conventional STAR line mode.
Not usable with Star Page mode.
- Supports high-speed data transmission
When using IEEE 1284, data transmission rate of 80 to 100 kbytes ensured.
- Supports both fixed lengths and variable length modes.
- Print speed selectable
- Post printing cut operation selectable
- All settings possible by raster commands.
Most settings are possible without DIPSW/memory switch settings.
- Support of printer driver that supports the raster mode.

The following shows the raster command details.

Note that if not specifically noted, the following commands are effective only in raster mode and the commands are ignored (Four bytes ignored) when other than the raster mode.

The raster image buffer in the command details described below indicate the raster dedicated image buffer, the length thereof (vertical direction dot count) differing between models.

The following commands are valid only when thermal has been selected. Their use is prohibited when slip and validation have been selected.

The following commands are valid only when Thermal is selected. Use is prohibited when Slip/Validation is selected.

ESC * r R

[Name] Initialize raster mode

| | | | | | |
|--------|-------------|-----|----|-----|----|
| [Code] | ASCII | ESC | * | r | R |
| | Hexadecimal | 1B | 2A | 72 | 52 |
| | Decimal | 27 | 42 | 114 | 82 |

[Defined Area] Thermal : -
Slip : -
Validation : -

[Initial Value] Thermal : -
Slip : -
Validation : -

[Function]
<Thermal>

Initializes raster mode.

This command is also valid when not in the raster mode.

However, initialization of the raster mode with this command is executed when entering the raster mode.

The following settings are initialized using this command.

- Raster page length setting (ESC * r P n NUL)
- Raster print quality setting (ESC * Q n NUL)
- Raster print quality setting (ESC * r K n NUL)
- Raster left margin setting (ESC * r m l n NUL)
- Raster right margin setting (ESC * r m r n NUL)
- Raster EOT mode setting (ESC FF EOT)
- Raster FF mode setting (ESC FF NUL)
- Clear raster image buffer

Note that when entering the raster mode, it executes the same process as initialization of the raster mode using this command.

However, because initialization is not performed when entering the raster mode only for the following settings, when initializing the following it sends this initialization command.

- Raster print quality setting (ESC * r K n NUL)

<Slip>, <Validation>

Use prohibited.

ESC * r A

[Name] Enter raster mode

| | | | | | |
|--------|-------------|-----|----|-----|----|
| [Code] | ASCII | ESC | * | r | A |
| | Hexadecimal | 1B | 2A | 72 | 41 |
| | Decimal | 27 | 42 | 114 | 65 |

[Defined Area] Thermal : -
Slip : -
Validation : -

[Initial Value] Thermal : -
Slip : -
Validation : -

[Function]
<Thermal>

Enters raster mode.

This command is ignored when in the raster mode.

The following shows the details regard processing of this command.

- (1) Reception of this command.
- (2) All data remaining in the reception buffer and image buffer is printed equivalent to the FF command.
- (3) Initialize raster mode
- (4) Enter raster mode

When entering raster mode, raster mode is initialized.

The following shows the contents of the initialization.

- Raster page length setting (ESC * r P n NUL)
- Raster print quality setting (ESC * Q n NUL)
- Raster left margin setting (ESC * r m l n NUL)
- Raster right margin setting (ESC * r m r n NUL)
- Raster EOT mode setting (ESC FF EOT)
- Raster FF mode setting (ESC FF NUL)
- Clear raster image buffer

(*) Not initialized when raster mode is entered only when using raster data print color settings.

<Slip>, <Validation>

Use prohibited.

ESC * r B

[Name] Quit raster mode

| | | | | | |
|--------|-------------|-----|----|-----|----|
| [Code] | ASCII | ESC | * | r | B |
| | Hexadecimal | 1B | 2A | 72 | 42 |
| | Decimal | 27 | 42 | 114 | 66 |

[Defined Area] Thermal : -
Slip : -
Validation : -

[Initial Value] Thermal : -
Slip : -
Validation : -

[Function]
<Thermal>

Quits raster mode.

When raster mode is quit, and raster data remains in the raster mode image buffer, the raster mode will be quit after executing raster EOT mode.

<Slip>, <Validation>
Use prohibited.

ESC * r C

[Name] Clear raster data

| | | | | | |
|--------|-------------|-----|----|-----|----|
| [Code] | ASCII | ESC | * | r | C |
| | Hexadecimal | 1B | 2A | 72 | 43 |
| | Decimal | 27 | 42 | 114 | 67 |

[Defined Area] Thermal : -
Slip : -
Validation : -

[Initial Value] Thermal : -
Slip : -
Validation : -

[Function]
<Thermal>

Clears the image buffer data of the raster mode.

<Slip>, <Validation>
Use prohibited.

ESC * r D n NUL

[Name] Drawer drive

| | | | | | | | |
|--------|-------------|-----|----|-----|----|---|-----|
| [Code] | ASCII | ESC | * | r | D | n | NUL |
| | Hexadecimal | 1B | 2A | 72 | 44 | n | 00 |
| | Decimal | 27 | 42 | 114 | 68 | n | 0 |

[Defined Area] Thermal : $0 \leq n \leq 3$

Slip : -

Validation : -

[Initial Value] Thermal : n = 0

Slip : -

Validation : -

[Function]

<Thermal>

Drives the drawer in the raster mode.

Drawer drive conditions conform to line mode setting command ESC BEL n1 n2.

n is a decimal description (max. 255 digits) using ASCII characters.

| n | Drive circuits |
|---|---|
| 0 | None |
| 1 | External device drive 1 drive |
| 2 | External device drive 2 drive |
| 3 | External device drive 1 drive and external device drive 2 drive |

<Slip>, <Validation>

Use prohibited.

ESC * r E n NUL

[Name] Set raster EOT mode

[Code] ASCII ESC * r E n NUL
 Hexadecimal 1B 2A 72 45 n 00
 Decimal 27 42 114 69 n 0

[Defined Area] Thermal : n = 0, 1, 2, 3, 8, 9, 12, 13
 Slip : -
 Validation : -

[Initial Value] Thermal : n = 13
 Slip : -
 Validation : -

[Function]
 <Thermal>

Set raster EOT mode

The EOT mode operates to execute using the raster document quit command ESC FF EOT. n is a decimal description (max. 255 digits) using ASCII characters.

EOT mode setting format

| n | Form Feed | Cut Feed | Cutter |
|----|----------------|----------------|----------------|
| 0 | Set To Default | Set To Default | Set To Default |
| 1 | ○ (*1) | -- | -- |
| 2 | ○ (*1) | ○ | -- |
| 3 | ○ (*1) | Tear Bar | -- |
| 8 | ○ (*1) | -- | Full Cut |
| 9 | ○ (*1) | ○ | Full Cut |
| 12 | ○ (*1) | -- | Partial Cut |
| 13 | ○ (*1) | ○ | Partial Cut |

(*1) Form Feed

When the printer is a model handling BM and is set for BM to be effective, the set raster mode page length is ignored and BM detecting is performed.

<Slip>, <Validation>

Use prohibited.

ESC * r F n NUL

[Name] Set raster FF mode

[Code] ASCII ESC * r F n NUL
 Hexadecimal 1B 2A 72 46 n 00
 Decimal 27 42 114 70 n 0

[Defined Area] Thermal : n = 0, 1, 2, 3, 8, 9, 12, 13
 Slip : -
 Validation : -

[Initial Value] Thermal : n = 13
 Slip : -
 Validation : -

[Function]
 <Thermal>

Sets raster FF mode.
 The FF mode operates to execute using the raster document quit command ESC FF NUL.
 n is a decimal description (max. 255 digits) using ASCII characters.

FF mode setting format

| n | Form Feed | Cut Feed | Cutter |
|----|----------------|----------------|----------------|
| 0 | Set To Default | Set To Default | Set To Default |
| 1 | o (*1) | -- | -- |
| 2 | o (*1) | o | -- |
| 3 | o (*1) | Tear Bar | -- |
| 8 | o (*1) | -- | Full Cut |
| 9 | o (*1) | o | Full Cut |
| 12 | o (*1) | -- | Partial Cut |
| 13 | o (*1) | o | Partial Cut |

(*1) Form Feed

When the printer is a model handling BM and is set for BM to be effective, the set raster mode page length is ignored and BM detecting is performed.

<Slip>, <Validation>

Use prohibited.

ESC * r P n NUL

[Name] Set raster page length

| | | | | | | | |
|--------|-------------|-----|----|-----|----|---|-----|
| [Code] | ASCII | ESC | * | r | P | n | NUL |
| | Hexadecimal | 1B | 2A | 72 | 50 | n | 00 |
| | Decimal | 27 | 42 | 114 | 80 | n | 0 |

[Defined Area] Thermal : -
Slip : -
Validation : -

[Initial Value] Thermal : Raster image buffer length
Slip : -
Validation : -

[Function]
<Thermal>

Sets raster page length.
n is a decimal description (max. 255 digits) using ASCII characters.

| | |
|------------|--|
| n | Page length |
| 0 | Continuous print mode (no page length setting) |
| $1 \leq n$ | Specify page length |

<Slip>, <Validation>

Use prohibited.

ESC * r Q n NUL

[Name] Set raster print quality

| | | | | | | | |
|--------|-------------|-----|----|-----|----|---|-----|
| [Code] | ASCII | ESC | * | r | Q | n | NUL |
| | Hexadecimal | 1B | 2A | 72 | 51 | n | 00 |
| | Decimal | 27 | 42 | 114 | 81 | n | 0 |

[Defined Area] Thermal : $0 \leq n \leq 2$
Slip : -
Validation : -

[Initial Value] Thermal : n = 0
Slip : -
Validation : -

[Function]
<Thermal>

Sets raster print quality.
n is a decimal description (max. 255 digits) using ASCII characters.

| | |
|---|-----------------------------|
| n | • Print quality |
| 0 | Specify high speed printing |
| 1 | Normal print quality |
| 2 | High print quality |

<Slip>, <Validation>

Use prohibited.

ESC * r m l n NUL

[Name] Set raster left margin

| | | | | | | | | |
|--------|-------------|-----|----|-----|-----|-----|---|-----|
| [Code] | ASCII | ESC | * | r | m | l | n | NUL |
| | Hexadecimal | 1B | 2A | 72 | 6D | 6C | n | 00 |
| | Decimal | 27 | 42 | 114 | 109 | 108 | n | 0 |

[Defined Area] Thermal : -
Slip : -
Validation : -

[Initial Value] Thermal : n = 0
Slip : -
Validation : -

[Function]
<Thermal>

Sets raster left margin.

This command sets the left margin to (n x 8) dots.

When the left margin exceeds the printable area, or if the left margin specification eliminates the print area ((printable region - right margin) \geq left margin specified value), this command is ignored.

n is a decimal description (max. 255 digits) using ASCII characters.

<Slip>, <Validation>

Use prohibited.

ESC * r m r n NUL

[Name] Set raster right margin

| | | | | | | | | |
|--------|-------------|-----|----|-----|-----|-----|---|-----|
| [Code] | ASCII | ESC | * | r | m | r | n | NUL |
| | Hexadecimal | 1B | 2A | 72 | 6D | 72 | n | 00 |
| | Decimal | 27 | 42 | 114 | 109 | 114 | n | 0 |

[Defined Area] Thermal : -
Slip : -
Validation : -

[Initial Value] Thermal : n = 0
Slip : -
Validation : -

[Function]
<Thermal>

Sets raster right margin.

This command sets the right margin to (n x 8) dots.

When the right margin exceeds the printable area, or if the right margin specification eliminates the print area ((printable region - left margin) \geq right margin) specified value, this command is ignored.

n is a decimal description (max. 255 digits) using ASCII characters.

<Slip>, <Validation>

Use prohibited.

ESC * r T n NUL

[Name] Set raster top margin

| | | | | | | | |
|--------|-------------|-----|----|-----|----|---|-----|
| [Code] | ASCII | ESC | * | r | T | n | NUL |
| | Hexadecimal | 1B | 2A | 72 | 54 | n | 00 |
| | Decimal | 27 | 42 | 114 | 84 | n | 0 |

[Defined Area] Thermal : $0 \leq n \leq 2$
 Slip : -
 Validation : -

[Initial Value] Thermal : -
 Slip : -
 Validation : -

[Function]

<Thermal>

Sets the raster top margin.

n is a decimal description (max. 255 digits) using ASCII characters.

| n | Top margin |
|---|--|
| 0 | Set To Default |
| 1 | Set top margin using reverse paper feed. |
| 2 | Set standard top margin. |

(*) This differs according to the model handling this command.

When in the raster mode, the top margin setting of line mode remains.

When quitting the raster mode, continue the top margin setting of the raster mode and return to the line mode.

<Slip>, <Validation>

Use prohibited.

ESC * r K n NUL

[Name] Set raster print color

| | | | | | | | |
|--------|-------------|-----|----|-----|----|---|-----|
| [Code] | ASCII | ESC | * | r | K | n | NUL |
| | Hexadecimal | 1B | 2A | 72 | 4B | n | 00 |
| | Decimal | 27 | 42 | 114 | 75 | n | 0 |

[Defined Area] Thermal : $0 \leq n \leq 3$

Slip : -
Validation : -

[Initial Value] Thermal : n = 0

Slip : -
Validation : -

[Function]
<Thermal>

Sets raster print color.
This command is effective only when specifying the 2 color mode using the line mode.
This command is ignored when not in the 2 color print mode.
n is a decimal description (max. 255 digits) using ASCII characters.

| n | Print color |
|---|-------------|
| 0 | Black |
| 1 | Cyan |
| 2 | Magenta |
| 3 | Yellow |

(*) This command is valid only when using a model that supports 2-color printing. This command is ignored on non-compatible models.

<Slip>, <Validation>
Use prohibited.

b n1 n2 data

[Name] Send raster data (auto line feed)

[Code] ASCII b n1 n2 d1 d2 ... dk
 Hexadecimal 62 n1 n2 d1 d2 ... dk
 Decimal 98 n1 n2 d1 d2 ... dk

[Defined Area] Thermal : $0 \leq n1 \leq 255, 0 \leq n2 \leq 255, 0 \leq d \leq 255$
 $k = n1 + n2 \times 256, 1 \leq k$

Slip : -
 Validation : -

[Initial Value] Thermal : -
 Slip : -
 Validation : -

[Function]
 <Thermal>

Sends raster data.
 Raster data is sent in $(n1 + n2 \times 256)$ byte counts as binary data.
 Raster data exceeding the print area currently set is discarded.
 The image buffer expanded position is automatically line fed one dot row and moved to the left margin on the next line after expanded the image buffer data 1 dot row using this command.
 Also, data expansion is duplicated on the data in the current image buffer (OR process).
 The following shows expanded image buffer for the set raster print color.
 n is a decimal description (max. 255 digits) using ASCII characters.

| Print color | Expanded image buffer |
|-------------|------------------------|
| Black | Image buffer for black |
| Cyan | Image buffer for color |
| Magenta | Image buffer for color |
| Yellow | Image buffer for color |

<Slip>, <Validation>
 Use prohibited.

k n1 n2 data

[Name] Transfer raster data

[Code] ASCII k n1 n2 d1 d2 ... dk
 Hexadecimal 6B n1 n2 d1 d2 ... dk
 Decimal 107 n1 n2 d1 d2 ... dk

[Defined Area] Thermal : $0 \leq n1 \leq 255, 0 \leq n2 \leq 255, 0 \leq d \leq 255$
 $k = n1 + n2 \times 256, 1 \leq k$

Slip : -
 Validation : -

[Initial Value] Thermal : -
 Slip : -
 Validation : -

[Function]
 <Thermal>

Sends raster data.
 Raster data is sent in $(n1 + n2 \times 256)$ byte counts as binary data.
 Raster data exceeding the print area currently set is discarded.
 The image buffer expanded position returns to the head of the current dot row without an automatic line fed after expanding the image buffer data 1 dot row using this command.
 Also, data expansion is duplicated on the data in the current image buffer (OR process).
 The following shows expanded image buffer for the set raster print color.
 n is a decimal description (max. 255 digits) using ASCII characters.

| Print color | Expanded image buffer |
|-------------|------------------------|
| Black | Image buffer for black |
| Cyan | Image buffer for color |
| Magenta | Image buffer for color |
| Yellow | Image buffer for color |

<Slip>, <Validation>
 Use prohibited.

ESC * r Y n NUL

[Name] Move vertical direction position (Line feed for specified dots)

| | | | | | | | |
|--------|-------------|-----|----|-----|----|---|-----|
| [Code] | ASCII | ESC | * | r | Y | n | NUL |
| | Hexadecimal | 1B | 2A | 72 | 59 | n | 00 |
| | Decimal | 27 | 42 | 114 | 89 | n | 0 |

[Defined Area] Thermal : -
Slip : -
Validation : -

[Initial Value] Thermal : -
Slip : -
Validation : -

[Function]
<Thermal>

Moves vertical direction position.

Moves position n dots with this command.

When the current page length setting is in continuous print mode, and n dots exceed the remaining dot count of the raster image buffer length, the data in the print buffer is printed, and paper is fed n dots when this command is received.

Also, when the page length is set, data in the print buffer is printed, and paper is fed once the set page length when this command is received. The remaining paper feed is performed at the print execution command thereafter.

n is a decimal description (max. 255 digits) using ASCII characters.

<Slip>, <Validation>

Use prohibited.

ESC FF NUL

[Name] Execute FF mode

| | | | | |
|--------|-------------|-----|----|-----|
| [Code] | ASCII | ESC | FF | NUL |
| | Hexadecimal | 1B | 0C | 00 |
| | Decimal | 27 | 12 | 0 |

[Defined Area] Thermal : -
Slip : -
Validation : -

[Initial Value] Thermal : -
Slip : -
Validation : -

[Function]
<Thermal>

Executes FF mode.

Executes operation specified by the FF mode setting command ESC * r F n NUL.

<Slip>, <Validation>

Use prohibited.

ESC FF EOT

[Name] Execute EOT mode

| | | | | |
|--------|-------------|-----|----|-----|
| [Code] | ASCII | ESC | FF | EOT |
| | Hexadecimal | 1B | 0C | 04 |
| | Decimal | 27 | 12 | 4 |

[Defined Area] Thermal : -
Slip : -
Validation : -

[Initial Value] Thermal : -
Slip : -
Validation : -

[Function]
<Thermal>

Executes EOT mode.
Executes operation specified by the EOT mode setting command ESC * r E n NUL.

<Slip>, <Validation>
Use prohibited.

ESC * r N n NUL

[Name] Discard specified byte count of data

| | | | | | | | |
|--------|-------------|-----|----|-----|----|---|-----|
| [Code] | ASCII | ESC | * | r | N | n | NUL |
| | Hexadecimal | 1B | 2A | 72 | 4E | n | 0 |
| | Decimal | 27 | 42 | 114 | 78 | n | 0 |

[Defined Area] Thermal : $1 \leq n \leq 9999$
Slip : -
Validation : -

[Initial Value] Thermal : -
Slip : -
Validation : -

[Function]
<Thermal>

Discard specified byte count of data

The number of bytes specified by n and later-received data are received and discarded.
n is a decimal description (max. 4 digits) using ASCII characters.
This command is value only when in raster mode.

<Slip>, <Validation>
Use prohibited.

ESC * r V m n NUL

[Name] Execute external buzzer drive

[Code] ASCII ESC * r V 1 n NUL
 Hexadecimal 1B 2A 72 56 31 n 0
 Decimal 27 42 114 86 49 n 0

[Defined Area] Thermal : m = 49, 50, 1 ≤ n ≤ 20
 Slip : -
 Validation : -

[Initial Value] Thermal : -
 Slip : -
 Validation : -

[Function]
 <Thermal>

Repeatedly drives the buzzer according to the ON/OFF conditions set by the external buzzer drive pulse condition command ESC GS EM DC1 m n1 n2.

m specifies the buzzer drive terminal to drive.

| m | Buzzer Drive Terminals |
|----|-------------------------|
| 49 | Buzzer drive terminal 1 |
| 50 | Buzzer drive terminal 2 |

Specifies the number of times to repeat buzzer drive with n.

Buzzer cannot ring while printer is printing.

This command is prohibited for use for anything other than ringing the buzzer.

(When this command is used for the drawer drive on models equipped with an external device terminal, it will be damaged, so it is absolutely prohibited.)

The buzzer can be stopped by pressing the FEED switch or the RELEASE switch while the buzzer is ringing, or opening the receipt cover or the slip cover.

It is necessary to set the conditions prior to entering raster mode using the external buzzer drive pulse conditions command ESC GS EM DC1 m n1 n2.

n is a decimal description (max. 255 digits) using ASCII characters.

[Ex.:]

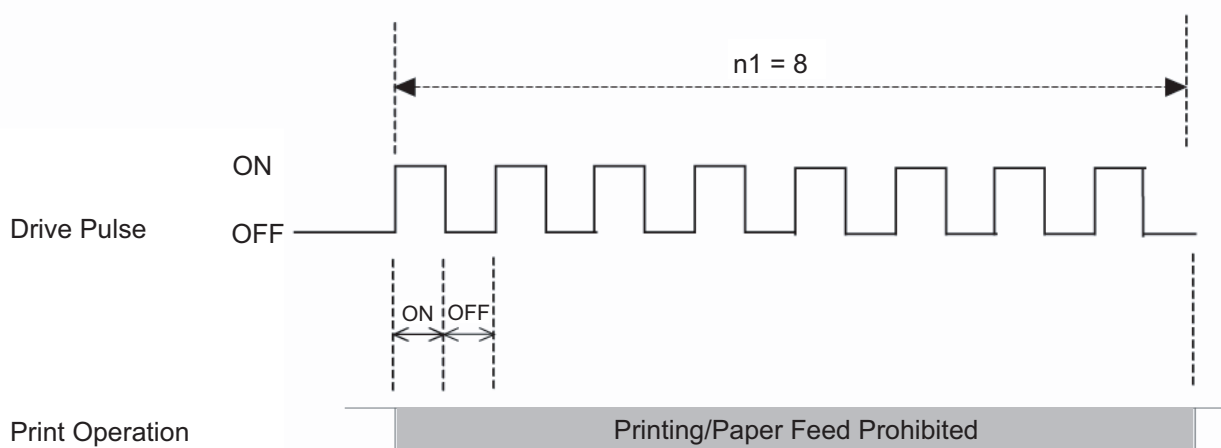

(Note) If the off time is set to 0 (zero), it is possible to ring the buzzer continuously for the amount of n1. For example, if on = 5 seconds, off = 0, and n1 = 20 times, the buzzer will ring for 100 seconds.

<Slip>, <Validation>
 Use prohibited.

3-5) Black Mark Related Command Details

The following commands control top of form functions using black mark paper.
 The following commands are effective only when black mark is set to be effective.

ESC d n

[Name] Auto - cutter:

| | | | | |
|--------|-------------|-----|-----|---|
| [Code] | ASCII | ESC | d | n |
| | Hexadecimal | 1B | 64 | n |
| | Decimal | 27 | 100 | n |

[Defined Area] Thermal : $0 \leq n \leq 3, 48 \leq n \leq 51$ ("0" $\leq n \leq$ "3")
 Slip : -
 Validation : -

[Initial Value] Thermal : -
 Slip : -
 Validation : -

[Function]
 <Thermal>

Executes the auto-cutter.
 After auto-cutter is executed, the printer considers that to be the top of the page.

| n | Auto cutter |
|-------|---|
| 0, 48 | Full cut at the current position. Print data in line buffer is printed before a full cut. This command is ignored if the printer is not equipped with an auto-cutter. |
| 1, 49 | Partial cut at the current position. Print data in line buffer is printed before a partial cut. This command is ignored if the printer is not equipped with an auto-cutter. |
| 2, 50 | After executing top of form, paper is fed to cutting position, then a full cut. Print data in line buffer is printed before the operation described above. This command is ignored if the printer is not equipped with an auto-cutter. |
| 3, 51 | After executing top of form, paper is fed to cutting position, then a partial cut. Print data in line buffer is printed before the operation described above. This command is ignored if the printer is not equipped with an auto-cutter. |

(*) The auto-cutter function operates in the following ways on models that only have a full cut or a partial cut.

- Models that perform only a full cut.: Executes a full cut when for instructions calling for a partial cut.
- Models that perform only a partial cut.: Executes a partial cut when there are for instructions calling for a full cut.

<Slip>, <Validation>
 Three bytes ignored

FF

[Name] Execute top of form

[Code] ASCII FF
Hexadecimal 0C
Decimal 12

[Defined Area] Thermal : -
Slip : -
Validation : -

[Initial Value] Thermal : -
Slip : -
Validation : -

[Function]

<Thermal>

Executes top of form.

<Slip>, <Validation>

One byte ignored

ESC C n

[Name] Set page length to n lines

[Code] ASCII ESC C n
Hexadecimal 1B 43 n
Decimal 27 67 n

[Defined Area] Thermal : $1 \leq n \leq 127$
Slip : -
Validation : -

[Initial Value] Thermal : (Form feed amount initial value x 42)
Slip : -
Validation : -

[Function]

<Thermal>

When black mark is effective, this command is ignored.

<Slip>, <Validation>

Three bytes ignored

ESC C 0 n

[Name] Set page length to n x 24 mm units

| | | | | | |
|--------|-------------|-----|----|---|---|
| [Code] | ASCII | ESC | C | 0 | n |
| | Hexadecimal | 1B | 43 | 0 | n |
| | Decimal | 27 | 67 | 0 | n |

[Defined Area] Thermal : $1 \leq n \leq 22$
 Slip : -
 Validation : -

[Initial Value] Thermal : (Form feed amount initial value x 42)
 Slip : -
 Validation : -

[Function]
 <Thermal>

When black mark is effective, this command is ignored.

<Slip>, <Validation>

Four bytes ignored

VT

[Name] Feed paper to vertical tab position

| | | |
|--------|-------------|----|
| [Code] | ASCII | VT |
| | Hexadecimal | 0B |
| | Decimal | 11 |

| | | | |
|----------------|------------|---|---|
| [Defined Area] | Thermal | : | - |
| | Slip | : | - |
| | Validation | : | - |

| | | | |
|-----------------|------------|---|---|
| [Initial Value] | Thermal | : | - |
| | Slip | : | - |
| | Validation | : | - |

[Function]

<Thermal>

When black mark is effective, this command is ignored.

<Slip>, <Validation>

One byte ignored

ESC B n1 n2 ... nk NUL

[Name] Set vertical tab position

| | | | | | | | | |
|--------|-------------|-----|----|----|----|----|----|-----|
| [Code] | ASCII | ESC | B | n1 | n2 | .. | nk | NUL |
| | Hexadecimal | 1B | 42 | n1 | n2 | .. | nk | 00 |
| | Decimal | 27 | 66 | n1 | n2 | .. | nk | 0 |

| | | | |
|----------------|------------|---|---------------------------------------|
| [Defined Area] | Thermal | : | $1 \leq n \leq 255, 0 \leq k \leq 16$ |
| | Slip | : | - |
| | Validation | : | - |

| | | | |
|-----------------|------------|---|---|
| [Initial Value] | Thermal | : | - |
| | Slip | : | - |
| | Validation | : | - |

[Function]

<Thermal>

When black mark is effective, this command is ignored.

<Slip>, <Validation>

Received and discarded up to <NUL>.

ESC B NUL

[Name] Clear vertical tab position

| | | | | |
|--------|-------------|-----|----|-----|
| [Code] | ASCII | ESC | B | NUL |
| | Hexadecimal | 1B | 42 | 00 |
| | Decimal | 27 | 66 | 0 |

[Defined Area] Thermal : -
Slip : -
Validation : -

[Initial Value] Thermal : -
Slip : -
Validation : -

[Function]

<Thermal>

When black mark is effective, this command is ignored.

<Slip>, <Validation>

Three bytes ignored

3-6) 2-Color Printing Command Details

The following commands control 2-color printing functions.

The following commands are effective only when using a model handling 2-color printing.

ESC RS c n

[Name] Set print color in 2-color print mode

| | | | | | |
|--------|-------------|-----|----|----|---|
| [Code] | ASCII | ESC | RS | c | n |
| | Hexadecimal | 1B | 1E | 63 | n |
| | Decimal | 27 | 30 | 99 | n |

[Defined Area] Thermal : $0 \leq n \leq 1, 48 \leq n \leq 49, ("0" \leq n \leq "1")$
 Slip : -
 Validation : -

[Initial Value] Thermal : $n = 0, 48$ (When in 2-color print mode)
 Slip : -
 Validation : -

[Function]
 <Thermal>

Specifies print color in 2 color print mode.
 This command is ignored when not in the 2-color print mode.
 Specifies black for the print color when in 2-color print mode.
 The specification of this command is cleared only when the printer is reset.
 The specification of this command is not cleared by ESC @ CAN.
 However, print color is initialized to black by the ESC @ and CAN only when in the compatible 2-color print mode.

| | |
|-------|------------------------------------|
| n | Specifies 2-color print mode color |
| 0, 48 | Black |
| 1, 49 | Red |

<Slip>, <Validation>

Only setting is valid
 Setting is valid after switching to thermal.

ESC RS C n

[Name] Select/cancel 2-color print mode

| | | | | | |
|--------|-------------|-----|----|----|---|
| [Code] | ASCII | ESC | RS | C | n |
| | Hexadecimal | 1B | 1E | 43 | n |
| | Decimal | 27 | 30 | 67 | n |

[Defined Area] Thermal : $0 \leq n \leq 2, 48 \leq n \leq 50$ ("0" $\leq n \leq$ "2"), n = 16, n = 32

Slip : -

Validation : -

[Initial Value] Thermal : n = 0, 48

Slip : -

Validation : -

[Function]

<Thermal>

| n | Print Mode Specification |
|-------|----------------------------|
| 0, 48 | Single Color Mode |
| 1, 49 | 2-color Mode |
| 16 | Low-power Consumption Mode |
| 32 | Double Resolution Mode |

- This command is ignored when the low-power consumption mode is selected by the DIP switches.
 - The specification of this command is not cleared by ESC @ CAN.
 - Prints data in line buffer, if unprinted data exists in the line buffer.
 - This command is processed after quitting the current print.
 - Commands that select the same mode are ignored in the currently selected mode.

<Slip>, <Validation>

Only setting is valid

Setting is valid after switching to thermal.

ESC 4

[Name] (Thermal) Specify black/white inversion/(Slip) specify black/white inversion/specify red/black color

| | | | |
|--------|-------------|-----|----|
| [Code] | ASCII | ESC | 4 |
| | Hexadecimal | 1B | 34 |
| | Decimal | 27 | 52 |

[Defined Area] Thermal : -
Slip : -
Validation : -

[Initial Value] Thermal : White/black inversion cancelled
Slip : White/black inversion cancelled/black color printing specified
Validation : White/black inversion cancelled/black color printing specified

[Function]
<Thermal>

Specifies white/black inversion for ANK characters and Kanji characters.
IBM block ignores white/black inversion.

<Slip>, <Validation>

This command function is based on the selection of red/black substitute function.
The red/black substitute function is selected by the memory switch or the command ESC GS 4 m n.
For details on selecting the red/black substitute function using a command, see the explanation of ESC GS 4 below, and for details on selecting the red/black substitute function using the memory switch, see the printer specifications manual.

(Note) The settings using this command are valid for all stations and modes.

ESC 5

[Name] (Thermal) Cancel black/white inversion/(Slip) cancel black/white inversion/specify red/black color

| | | | |
|--------|-------------|-----|----|
| [Code] | ASCII | ESC | 5 |
| | Hexadecimal | 1B | 35 |
| | Decimal | 27 | 53 |

[Defined Area] Thermal : -
Slip : -
Validation : -

[Initial Value] Thermal : White/black inversion cancelled
Slip : White/black inversion cancelled/black color printing specified
Validation : White/black inversion cancelled/black color printing specified

[Function]
<Thermal>

Cancels white/black inversion for ANK characters and Kanji characters.

<Slip>, <Validation>

This command function is based on the selection of red/black substitute function.
The red/black substitute function is selected by the memory switch or the command ESC GS 4 m n.
For details on selecting the red/black substitute function using a command, see the explanation of ESC GS 4 below, and for details on selecting the red/black substitute function using the memory switch, see the printer specifications manual.

(Note) The settings using this command are valid for all stations and modes.

ESC RS d n

[Name] Set print density

[Code] ASCII ESC RS d n
 Hexadecimal 1B 1E 64 n
 Decimal 27 30 100 n

[Defined Area] Thermal : 0 ≤ n ≤ 15
 48 ≤ n ≤ 57 ("0" ≤ n ≤ "9"), 65 ≤ n ≤ 70 ("A" ≤ n ≤ "F")
 Slip : -
 Validation : -
 [Initial Value] Thermal : Memory switch setting
 Slip : -
 Validation : -

[Function]
 <Thermal>

Sets print density.
 This command stops printing to be executed.
 When in 2-color print mode, this can set the print density of red print.

| n | Print Density | |
|--------|----------------------------|---|
| | Single Color Printing Mode | 2-color Printing Mode Red Print Density |
| 0, 48 | Print density 1.3 | Print density 1.2 |
| 1, 49 | Print density 1.2 | Print density 1.2 |
| 2, 50 | Print density 1.1 | Print density 1.0 |
| 3, 51 | Print density 1.0 | Print density 1.0 |
| 4, 52 | Print density 0.9 | Print density 1.0 |
| 5, 53 | Print density 0.8 | Print density 0.8 |
| 6, 54 | Print density 0.7 | Print density 0.8 |
| 7, 55 | (Reserved) | (Reserved) |
| 8, 56 | (Reserved) | (Reserved) |
| 9, 57 | (Reserved) | (Reserved) |
| 10, 65 | (Reserved) | (Reserved) |
| 11, 66 | (Reserved) | (Reserved) |
| 12, 67 | (Reserved) | (Reserved) |
| 13, 68 | (Reserved) | (Reserved) |
| 14, 69 | (Reserved) | (Reserved) |
| 15, 70 | (Reserved) | (Reserved) |

<Slip>, <Validation>

Only setting is valid
 Setting is valid after switching to thermal.

ESC RS r n

[Name] Set printing speed

| | | | | | |
|--------|-------------|-----|----|-----|---|
| [Code] | ASCII | ESC | RS | r | n |
| | Hexadecimal | 1B | 1E | 72 | n |
| | Decimal | 27 | 30 | 114 | n |

[Defined Area] Thermal : $0 \leq n \leq 2, 48 \leq n \leq 50, ("0" \leq n \leq "2")$
 Slip : -
 Validation : -

[Initial Value] Thermal : Memory switch setting
 Slip : -
 Validation : -

[Function]

<Thermal>

Sets print speed.

This command stops printing to be executed.

Because 2-color print mode prints in one speed, the speed settings with this command are invalid.

This command setting becomes valid when returned from the two-color print mode to the single color print mode.

| n | Print Speed | |
|-------|----------------------------|-----------------------------|
| | Single Color Printing Mode | 2-color Printing Mode |
| 0, 48 | High speed | 2-color Printing Mode Speed |
| 1, 49 | Mid-speed | 2-color Printing Mode Speed |
| 2, 50 | Slow speed | 2-color Printing Mode Speed |

<Slip>, <Validation>

Only setting is valid

Setting is valid after switching to thermal.

ESC FS q n [x11 x12 y11 y12 d1 ... dk]1 ... [xn1 xn2 yn1 yn2 d1 ... dk] n

[Name] Register logo

| | | | | | | | | | | | | | | | | | | | | |
|--------|-------------|-----|----|-----|---|------|-----|-----|-----|----|----|------|----|------|-----|-----|-----|----|----|------|
| [Code] | ASCII | ESC | FS | q | n | [x11 | x12 | y11 | y12 | d1 | .. | dk]1 | .. | [xn1 | xn2 | yn1 | yn2 | d1 | .. | dk]n |
| | Hexadecimal | 1B | 1C | 71 | n | [x11 | x12 | y11 | y12 | d1 | .. | dk]1 | .. | [xn1 | xn2 | yn1 | yn2 | d1 | .. | dk]n |
| | Decimal | 27 | 28 | 113 | n | [x11 | x12 | y11 | y12 | d1 | .. | dk]1 | .. | [xn1 | xn2 | yn1 | yn2 | d1 | .. | dk]n |

| | | | |
|-----------------|------------|---|--|
| [Defined Area] | Thermal | : | $1 \leq n \leq 255$ |
| | | | $0 \leq xn1 \leq 255, 0 \leq xn2 \leq 3 \quad 1 \leq (xn1 + xn2 \times 256) \leq 1023$ |
| | | | $0 \leq yn1 \leq 255, 0 \leq yn2 \leq 1 \quad 1 \leq (yn1 + yn2 \times 256) \leq 288$ |
| | | | $0 \leq d \leq 255$ |
| | | | $k = \{(xn1 + xn2 \times 256) \times (yn1 + yn2 \times 256) \times 8\}$ |
| | Slip | : | $1 \leq n \leq 255$ |
| | | | $0 \leq xn1 \leq 255, 0 \leq xn2 \leq 3 \quad 1 \leq (xn1 + xn2 \times 256) \leq 1023$ |
| | | | $0 \leq yn1 \leq 255, 0 \leq yn2 \leq 1 \quad 1 \leq (yn1 + yn2 \times 256) \leq 288$ |
| | | | $0 \leq d \leq 255$ |
| | | | $k = \{(xn1 + xn2 \times 256) \times (yn1 + yn2 \times 256) \times 8\}$ |
| | Validation | : | $1 \leq n \leq 255$ |
| | | | $0 \leq xn1 \leq 255, 0 \leq xn2 \leq 3 \quad 1 \leq (xn1 + xn2 \times 256) \leq 1023$ |
| | | | $0 \leq yn1 \leq 255, 0 \leq yn2 \leq 1 \quad 1 \leq (yn1 + yn2 \times 256) \leq 288$ |
| | | | $0 \leq d \leq 255$ |
| | | | $k = \{(xn1 + xn2 \times 256) \times (yn1 + yn2 \times 256) \times 8\}$ |
| [Initial Value] | Thermal | : | - |
| | Slip | : | - |
| | Validation | : | - |

[Function]
Parameter details

- n: Specifies registered logo count
- xn1, xn2: Horizontal size of registered logo $\{(xn1 + xn2 \times 256) \times 8\}$ dots
- yn1, yn2: Vertical size of registered logo $\{(yn1 + yn2 \times 256) \times 8\}$ dots
- d: Registered logo data
- k: Logo data count

This command should be specified at the top of the line.

When the first parameter is determined to be free of error, the printer starts processing this command.

When logo register processing starts, all previously defined data is deleted.(It is not possible to re-register a portion of a plurality of defined logo data.)

Logo registration numbers are defined in rising order from 1.

If the defined area specified by the parameter is not empty, or if there is an error in the parameter specification, register processing is aborted.(The pre-registered and complete data is effective.)

The printer should be reset if logo registration is completed or register processing is aborted.

If an error occurs while performing register processing (the time from when the first parameter is OK until the printer initialization is completed after registering a logo), error processing, mechanical operation and status processing cannot be performed. Also, data must not be sent from the host during that time.

This command is executed only for logo registration and does not accompany the printing operation.

Logos are printed using the ESC FS p (print NV logo) command.

- The NV memory capacity is 4 Mbits (512 Kbytes = 524,288 bytes).

However, 4 Kbytes (4,096 bytes) are kept as parameter information separate to the data so the data region memory capacity is 520,192 Bytes.

Ex.: When the registered data size per each one is 6 Kbytes (6,144 bytes), it is possible to register $520,192/6144 = 84$.

<When registering logos for 2 color printing>

Registration is possible regardless of the 2 color printing mode being specified or cancelled. Register logos with the same capacity as the logo register number k (odd number) and k + 1 (even number).

If the capacity differs or the logo register number is 255, this command is ignored by the logo print command in the 2 color print mode.

(Note) The registered data is shared by all stations and modes.

If this command is used frequently, there is the possibility of damaging the non-volatile memory. Write to the non-volatile memory less than 10 times in one day.

Relationship of logo and registered data
 $x_n = x_{n1} + x_{n2} \times 256$, $y_n = y_{n1} + y_{n2} \times 256$

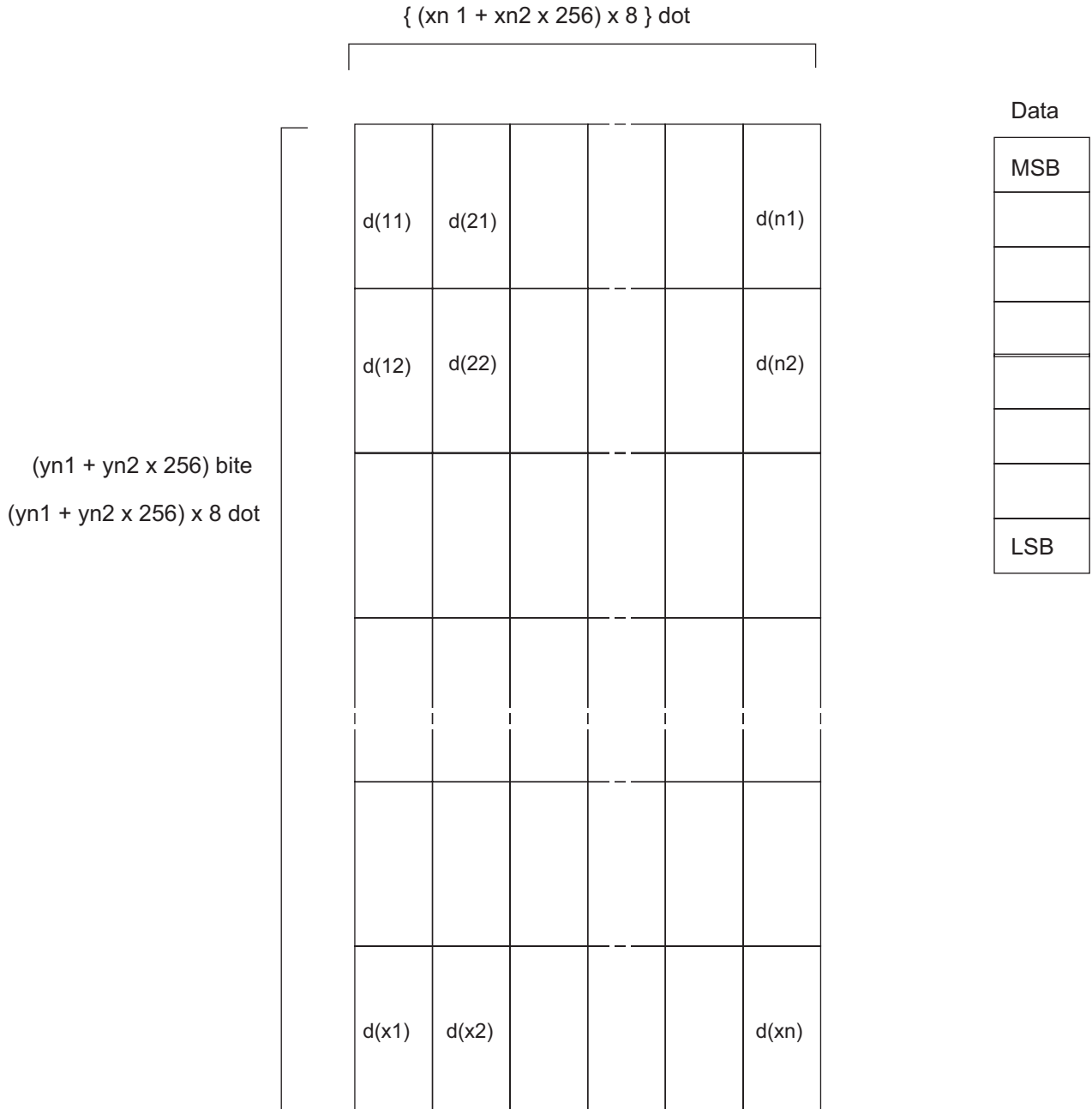

ESC FS p n m

| | | | | | | |
|--------|-------------|-----|----|-----|---|---|
| [Name] | Print logo | | | | | |
| [Code] | ASCII | ESC | FS | p | n | m |
| | Hexadecimal | 1B | 1C | 70 | n | m |
| | Decimal | 27 | 28 | 112 | n | m |

| | | | |
|----------------|------------|---|---|
| [Defined Area] | Thermal | : | $1 \leq n \leq 255$ |
| | | | $0 \leq m \leq 3, 48 \leq m \leq 51, ("0" \leq m \leq "3")$ |
| | Slip | : | $1 \leq n \leq 255$ |
| | | | $0 \leq m \leq 3, 48 \leq m \leq 51, ("0" \leq m \leq "3")$ |
| | Validation | : | $1 \leq n \leq 255$ |
| | | | $0 \leq m \leq 3, 48 \leq m \leq 51, ("0" \leq m \leq "3")$ |

| | | | |
|-----------------|------------|---|---|
| [Initial Value] | Thermal | : | - |
| | Slip | : | - |
| | Validation | : | - |

[Function] Prints the logo of registration number n registered using the logo registration command ESC FS q according to the print mode m.

n: Logo Specification

| n | Function |
|----------|-----------------------|
| 1 to 255 | Specified logo number |

m: Printing Mode

| m | Logo print mode |
|-------|-----------------------|
| 0, 48 | Normal mode |
| 1, 49 | Double wide mode |
| 2, 50 | Double high mode |
| 3, 51 | Double high/wide mode |

If the parameter is within the defined region, execute this command after printing the unprinted data in the line buffer.

(Unprinted data is printed regardless of whether the specified logo was registered by n.))

It is not possible to print with other data in one line (characters, bit images, bar codes).

Form feed obeys the vertical print size of the logo.

Print modes, excluding upside-down printing (enhanced, double, underline, character size, black/white inverted, and 90° right rotation) are unaffected.

If the logo horizontal print size exceeds the horizontal print region, the portion exceeding the area is not printed.

Logos are printed according to the following command settings.

- Left margin (ESC I n)
- Right margin (ESC Q n)
- Position alignment (ESC GS a n)
- Absolute position movement (ESC GS A n1 n2)
- Relative position movement (ESC GS R n1 n2)
- Horizontal tab (HT)
- Upside-down printing (SI)

<When using the 2 color print mode>

When the logo register number n is odd:

Register number n is printed in black; register number n + 1 is printed in red and overlapped.

The command is ignored when the capacity of the register number n and the capacity of the register number n + 1 are different.

The command is ignored when the register number n = 255 is specified.

When the logo register number n is even:

Register number n is printed in black; register number n - 1 is printed in red and overlapped.

The command is ignored when the capacity of the register number n and the capacity of the register number n - 1 are different.

The command is ignored when the register number n = 255 is specified.

3-7) Mark Command Details

This command is specialized to mark sheet printing for lotteries. This command can print lines.

Print Sample

<Print Sample>

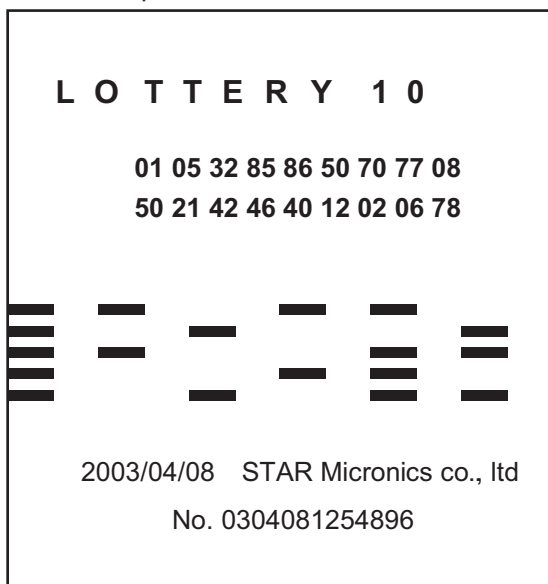

Command Transmission Example

- Mark Format
 - Mark Height $h = 10$ dots; Mark Line Feed Amount $V = 20$ dots
 - Mark number 0: Mark Color $c = \text{White}$; Mark Horizontal Width $w = 16$ dots
 - Mark number 1: Mark Color $c = \text{Black}$; Mark Horizontal Width $w = 40$ dots
 - Mark number 2: Mark Color $c = \text{White}$; Mark Horizontal Width $w = 40$ dots

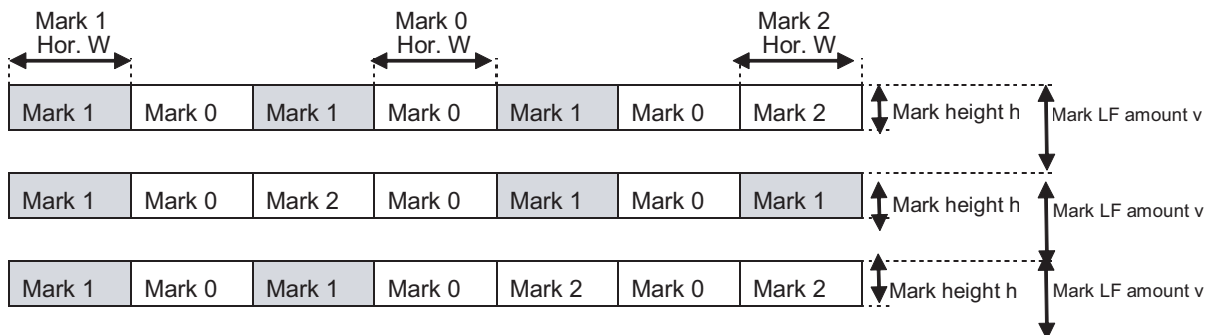

- Transmission Example
 - (1) Mark Height; Line Feed Amount Setting
`<ESC> <GS> * 1 h v (h = "010", v = "020")`
 - (2) Color of Each Mark Number, Horizontal Width Setting
`<ESC> <GS> * 2 m c w (Mark Number 0 Setting: m = "0", c = "0", w = "016")`
`<ESC> <GS> * 2 m c w (Mark Number 1 Setting: m = "1", c = "1", w = "040")`
`<ESC> <GS> * 2 m c w (Mark Number 2 Setting: m = "2", c = "0", w = "040")`
 - (3) Register mark format specified by (1) and (2) in advance to the non-volatile memory.
 (It is possible to print a mark without registering in the non-volatile memory.)
`<ESC> <GS> * W`
 - (4) Mark Printing
`<ESC><GS> * 0 n m1 m2 m3 m4 m5 m6 m7`
 (n = "007", m1 = "1", m2 = "0", m3 = "1", m4 = "0", m5 = "1", m6 = "0", m7 = "2")
`<ESC><GS> * 0 n m1 m2 m3 m4 m5 m6 m7`
 (n = "007", m1 = "1", m2 = "0", m3 = "2", m4 = "0", m5 = "1", m6 = "0", m7 = "1")
`<ESC><GS> * 0 n m1 m2 m3 m4 m5 m6 m7`
 (n = "007", m1 = "1", m2 = "0", m3 = "1", m4 = "0", m5 = "2", m6 = "0", m7 = "2")

ESC GS * 0 n m1 m2 m3 ... mk

[Name] Print Mark

| | | | | | | | | | | | |
|--------|-------------|-----|----|----|----|---|----|----|----|-----|----|
| [Code] | ASCII | ESC | GS | * | 0 | n | m1 | m2 | m3 | ... | mk |
| | Hexadecimal | 1B | 1D | 2A | 30 | n | m1 | m2 | m3 | ... | mk |
| | Decimal | 27 | 29 | 42 | 48 | n | m1 | m2 | m3 | ... | mk |

[Defined Area] Thermal : "001" ≤ n ≤ "255", "0" ≤ m ≤ "9", k = n

Slip : -

Validation : -

[Initial Value] Thermal : -

Slip : -

Validation : -

[Function]

<Thermal>

Prints mark number specified by m, based on the pre-specified mark format (mark height, mark line feed amount, mark color, and mark horizontal width).

n indicates the number of marks to print. When there are 10 marks (m1 to m10), n = "010."

m indicates the mark number to print.

n, m are ASCII character strings that are expressed in decimal. They are composed of character codes from "0" to "9."

This command is ignored if print data exists in the image buffer.

Therefore, this cannot exist with other print data (characters, bit images, bar codes).

If the specified mark does not fit in the remaining print region, the number of bytes specified by n are received and discarded.

If n is outside of the defined area, data thereafter is processed as normal data.

This command is affected by position alignment, left margin, position movement, position such as horizontal tabs, and upside-down printing.

<Slip>, <Validation>

All data received and discarded.

ESC GS * 1 h v

[Name] Specify mark height and line feed

| | | | | | | | | | | | | | | | | | | | |
|--------|-------------|-----|----|----|----|---|---|--|--|--|--|--|--|--|--|--|--|--|--|
| [Code] | ASCII | ESC | GS | * | 1 | h | v | | | | | | | | | | | | |
| | Hexadecimal | 1B | 1D | 2A | 31 | h | v | | | | | | | | | | | | |
| | Decimal | 27 | 29 | 42 | 49 | h | v | | | | | | | | | | | | |

[Defined Area] Thermal : "001" ≤ h ≤ "255", "001" ≤ v ≤ "255", h ≤ v
 Slip : -
 Validation : -

[Initial Value] Thermal : Non-volatile memory
 Slip : -
 Validation : -

[Function]
 <Thermal>

Specifies mark height and line feed
 v indicates mark height (number of dots); v indicates mark line feed amount (number of dots).
 h, v are ASCII character strings that are expressed in decimal. They are composed of character codes from "0" to "9."
 If a small line feed amount is specified, there is the possibility that intermittent printing could occur, so a setting of v = 16 dots or higher is recommended.

<Slip>, <Validation>
 Only setting is valid
 Setting is valid after switching to thermal.

ESC GS * 2 m c w

[Name] Specifies mark color and mark horizontal width in each mark number.

| | | | | | | | | |
|--------|-------------|-----|----|----|----|---|---|---|
| [Code] | ASCII | ESC | GS | * | 2 | m | c | w |
| | Hexadecimal | 1B | 1D | 2A | 32 | m | c | w |
| | Decimal | 27 | 29 | 42 | 50 | m | c | w |

[Defined Area] Thermal : "0" ≤ m ≤ "9", "0" ≤ c ≤ "1", "001" ≤ w ≤ "999"
 Slip : -
 Validation : -

[Initial Value] Thermal : Non-volatile memory
 Slip : -
 Validation : -

[Function]
 <Thermal>

Specifies mark color and mark horizontal width in each mark number.
 m indicates the mark number.
 c indicates the mark color.
 w indicates the mark horizontal width (number of dots).
 If w exceeds the currently set print region, this command is ignored.
 m, c, w are ASCII character strings that are expressed in decimal. They are composed of character codes from "0" to "9."

| c | Mark Color |
|---------|------------|
| "0"(48) | White |
| "1"(49) | Black |

<Slip>, <Validation>
 Only setting is valid
 Setting is valid after switching to thermal.

ESC GS * W

[Name] Register mark format to non-volatile memory

| | | | | | |
|--------|-------------|-----|----|----|----|
| [Code] | ASCII | ESC | GS | * | W |
| | Hexadecimal | 1B | 1D | 2A | 57 |
| | Decimal | 27 | 29 | 42 | 87 |

[Defined Area] Thermal : -
Slip : -
Validation : -

[Initial Value] Thermal : -
Slip : -
Validation : -

[Function] Registers the mark format (mark height, mark line feed amount, mark color, and mark horizontal width) in non-volatile memory.
After registration to the non-volatile memory, execute a printer reset.

ESC GS * C

[Name] Initialize mark format in non-volatile memory

| | | | | | |
|--------|-------------|-----|----|----|----|
| [Code] | ASCII | ESC | GS | * | C |
| | Hexadecimal | 1B | 1D | 2A | 43 |
| | Decimal | 27 | 29 | 42 | 67 |

[Defined Area] Thermal : -
Slip : -
Validation : -

[Initial Value] Thermal : -
Slip : -
Validation : -

[Function] Initializes the mark format (mark height, mark line feed amount, mark color, and mark horizontal width) registered in non-volatile memory.
After initialization, resets the printer.

Mark Format Initial Value

- Mark Height: "016" (16 dots)
- Mark Line Feed Amount: "032" (32 dots)
- Mark Color: "0" (White → All Mark Numbers)
- Mark Horizontal Width: "080" (80 dots) → All Mark Numbers)

3-8) AUTO LOGO Function Command Details

If the portion that was changed was only the product name in a system, like the one below, already operating, this command functions to print a logo like the one below by only changing the product name. This function has two operating modes.

1) Standard Auto Logo Function

Preset the Auto Logo function, and execute the following operations with the printing cut command under the existing system as a trigger.

- (1) Auto Logo function starts up using the existing system cut command as a trigger.
- (2) Execute printing if print data exists in the image buffer.
- (3) Execute user macro 1.
- (4) Auto Logo Printing
- (5) Execute user macro 2.

By Auto Logo embedding a preset command character “/” and the logo number “2” to print, in the current print data, logo 2 is printed by the (4) Auto Logo Print. In other words, If “CHEESE BURGER / 2” is registered as a product, a coupon for logo 2 will automatically printed for the purchaser of the cheese burger. Also, if logo 1 of the header is used in the company logo, and “cut command + logo 1 print command” are registered in the user macro 2 of (5), the company name of logo 1 will be printed. The user macro 1 of (3) is used when a center alignment of the auto logo is necessary. In such a case, it is necessary to register the left alignment command in the user macro 2 of (5), and to return based on the settings.

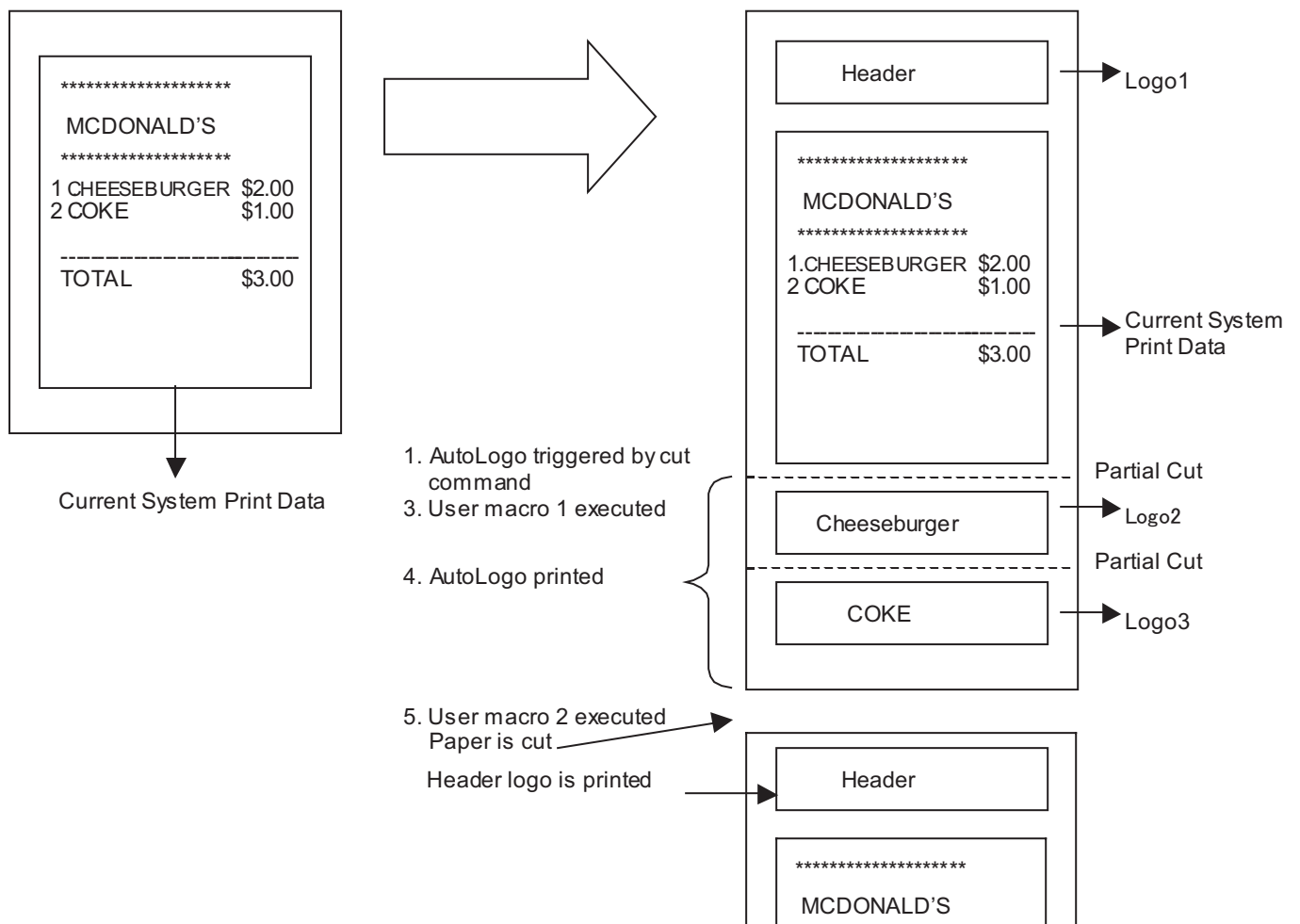

2) Simple Auto Logo Function

Preset the simple Auto Logo function, and execute the following operations with the printing cut command under the existing system as a trigger.

- (1) Simple Auto Logo function starts up using the existing system cut command as a trigger.
- (2) Center alignment command process
- (3) Execute printing of logo 2.
- (4) Paper is fed to cutting position, then a partial cut is executed.
- (5) Execute printing of logo 1.
- (6) Recover position alignment command to setting to before execution of simple Auto Logo

With the simple Auto Logo function the logo number of the logo to print is predetermined.

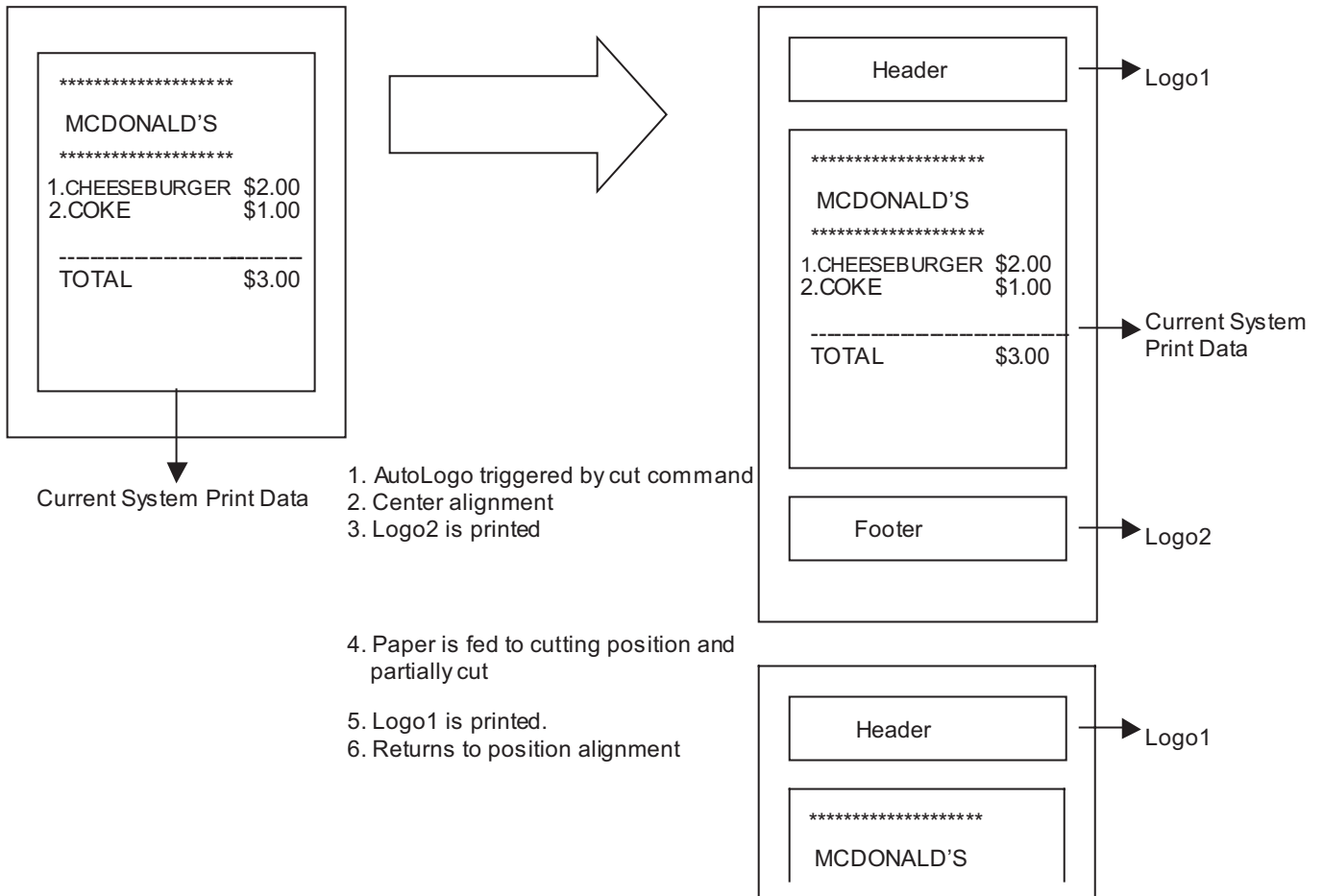

Command Transmission Example

- 1) Set the Auto Logo function in advance and register to the non-volatile memory.

| | |
|--|--|
| ESC GS / 1 n (n = 0x01): ESC GS / 2 n (n = "/"): ESC GS / 3 nL nH d1 d2 ... dk: nL = 4 nH = 0: d1 = 0x1b d2 = 0x1d d2 = 0x61 d3 = 0x01: ESC GS / 4 nL nH d1 d2 ... dk: nL = 12 nH = 0: d1 = 0x1b d2 = 0x64 d3 = 0x03: d4 = 0x1b d5 = 0x1c d6 = 0x70 d7 = 0x01 d8 = 0x00: d9 = 0x1b d10 = 0x1d d11 = 0x61 d12 = 0x00: ESC GS / 5 n (n = 0x01): ESC GS / 6 n (n = 0x01): ESC GS / W: | Auto Logo Function ON Auto Logo Command Character ("/") Specification User macro 1 definition Register macro data count = 4 bytes Registration macro <ESC GS a 1: Center alignment> User macro 2 definition Register macro data count = 12 bytes Registered macro <ESC d 3: Cut position partial Cut> <ESC FS p 1 0 : Logo 1 print> <ESC GS a 0: Left alignment> Auto Logo command character, space conversion Partial cut valid just prior to Auto Logo printing Register Auto Logo definition data to non-volatile memory. |
|--|--|

- 2) Embed registered command character in print data and transmit.
 "CHEESE BURGER/2" → "/" is recognized as the command character.
 The command character is converted to a space and "2" specifies logo 2.

ESC GS / W

[Name] Register Auto Logo setting to non-volatile memory

| | | | | | |
|--------|-------------|-----|----|----|----|
| [Code] | ASCII | ESC | GS | / | W |
| | Hexadecimal | 1b | 1d | 2f | 57 |
| | Decimal | 27 | 29 | 47 | 87 |

[Defined Area] Thermal : -
Slip : -
Validation : -

[Initial Value] Thermal : -
Slip : -
Validation : -

[Function] Registers Auto Logo setting to non-volatile memory.
After registration ends, resets the printer.
This command is ignored while Auto Logo is executing.

ESC GS / C

[Name] Initialize Auto Logo setting from non-volatile memory

| | | | | | |
|--------|-------------|-----|----|----|----|
| [Code] | ASCII | ESC | GS | / | C |
| | Hexadecimal | 1b | 1d | 2f | 43 |
| | Decimal | 27 | 29 | 47 | 67 |

[Defined Area] Thermal : -
Slip : -
Validation : -

[Initial Value] Thermal : -
Slip : -
Validation : -

[Function] Initializes registered data of the Auto Logo function in the non-volatile memory.
After initialization ends, resets the printer.
This command is ignored while Auto Logo is executing.

The following shows the initial values of the Auto Logo function.

| | Initial Value |
|---|---------------|
| Auto Logo Function | OFF |
| Command Character | None |
| User Macro 1 | None |
| User Macro 2 | None |
| Convert Command Character | Do not print |
| Partial Cut Prior to Auto Logo Printing | Invalid |

ESC GS / 1 n

[Name] Set ON/OFF for Auto Logo function

[Code] ASCII ESC GS / 1 n
 Hexadecimal 1b 1d 2f 31 n
 Decimal 27 29 47 49 n

[Defined Area] Thermal : 0 ≤ n ≤ 2
 Slip : -
 Validation : -

[Initial Value] Thermal : n = 0
 Slip : -
 Validation : -

[Function]
 <Thermal>

Sets ON/OFF for Auto Logo function.
 This setting is registered to non-volatile memory by the ESC GS / W command.
 When in the raster mode, the Auto Logo function is ignored.
 This command is ignored while Auto Logo is executing.

| n | Setting |
|---|---|
| 0 | Auto Logo Function OFF |
| 1 | Standard Auto Logo Function ON <Operating Specifications> (1) Auto Logo function starts up using the existing system cut command as a trigger. (2) Execute printing if print data exists in the image buffer. (3) Execute user macro 1. (4) Auto Log Printing (5) Execute user macro 2. |
| 2 | Simple Auto Logo Function ON <Operating Specifications> (1) Auto Logo function starts up using the existing system cut command as a trigger. (2) Execute printing if print data exists in the image buffer. (3) Execute center alignment. (4) Print logo 2 (2-color printing setting: Logo 3) (5) Paper is fed to cutting position, then a partial cut is executed. (6) Printing of logo 1. (7) Recover position alignment setting (Note) When this is set, user macros and command characters are invalid. When this is set, the command character “/” is printed as “/” .) |
| | |

The following shows the command that is the trigger for the Auto Logo function.
 If the standard Auto Logo function is turned ON by n = 1, the trigger command below functions only as a trigger, so the cutting operation is not executed. Therefore, it is necessary to register an arbitrary cutting command in user macro 2.
 If the simple Auto Logo function is turned ON by n = 2, the cutting command is executed, and is the trigger for the simple Auto Logo function.

- ESC d n: Cut Command
- FF: Allocated to cut function

<Slip>, <Validation>
 Only setting is valid
 Setting is valid after switching to thermal.

ESC GS / 2 n

[Name] Set command characters

| | | | | | | |
|--------|-------------|-----|----|----|----|---|
| [Code] | ASCII | ESC | GS | / | 3 | n |
| | Hexadecimal | 1b | 1d | 2f | 32 | n |
| | Decimal | 27 | 29 | 47 | 50 | n |

[Defined Area] Thermal : $32 \leq n \leq 127, n = 0$
 Slip : -
 Validation : -

[Initial Value] Thermal : $n = 0$
 Slip : -
 Validation : -

[Function]
 <Thermal>

Sets command character for the Auto Logo function.
 This setting is registered to non-volatile memory by the ESC GS / W command.
 This command is ignored while Auto Logo is executing.

| n | Setting |
|-----------|---------------------------|
| 32 to 127 | Command Character |
| 0 | No set command characters |

Command characters are characters that are commands for specifying the logo number to print with Auto Logo printing.

If the “/” is specified for the command character, “/2/3” is embedded in the print data.

The printer processes “/” not as character data but as a command, stores the number continuing after, and prints as an Auto Logo in the stored order.

Therefore, if “/2/3/” is embedded, the Auto Logo is printed in the order of logo 2, logo 3.

At that time, if the specified logo is not registered, logo printing is ignored.

If the setting is for not command character setting, no logo will be printed.

Note that “/2/3” is processed as a command so there is no print.

However, “/2/3/” is converted to a space by the ESC GS /5 n command.

Also, only the initial logo is printed if the same logo is duplicated, such as in “/2/3/2/2.”

32 logos can be stored as Auto Logos.

Continuing the command character, the following shows the defined area of the character d of the logo number specification.

“1” $\leq d \leq$ “9” (49 $\leq d \leq$ 57) → Logo number 1 to 9

“A” $\leq d \leq$ “F” (65 $\leq d \leq$ 70) → Logo number 10 to 16

<Slip>, <Validation>

Only setting is valid

Setting is valid after switching to thermal.

ESC GS / 3 nL nH d1 d2 ... dk

[Name] Set user macro 1

| | | | | | | | | | | | |
|--------|-------------|-----|----|----|----|----|----|----|----|-----|----|
| [Code] | ASCII | ESC | GS | / | 3 | nL | nH | d1 | d2 | ... | dk |
| | Hexadecimal | 1b | 1d | 2f | 33 | nL | nH | d1 | d2 | ... | dk |
| | Decimal | 27 | 29 | 47 | 51 | nL | nH | d1 | d2 | ... | dk |

[Defined Area] Thermal : $1 \leq nL \leq 64, nH = 0$
 $1 \leq (nL + nH \times 256) \leq 64$
 $dk = (nL + nH \times 256)$
 $0 \leq d \leq 255$

Slip : -

Validation : -

[Initial Value] Thermal : No user macro 1 setting

Slip : -

Validation : -

[Function]

<Thermal>

Sets user macro 1 for the Auto Logo function.

This setting is registered to non-volatile memory by the ESC GS / W command.

This command is ignored while Auto Logo is executing.

Registers print data in user macro 1.

Maximum 64 bytes of registered data

Note that registering Auto Logo command characters in the user macros is prohibited.

<Slip>, <Validation>

Only setting is valid

Setting is valid after switching to thermal.

ESC GS / 4 nL nH d1 d2 ... dk

[Name] Set user macro 2

| | | | | | | | | | | | |
|--------|-------------|-----|----|----|----|----|----|----|----|-----|----|
| [Code] | ASCII | ESC | GS | / | 4 | nL | nH | d1 | d2 | ... | dk |
| | Hexadecimal | 1b | 1d | 2f | 34 | nL | nH | d1 | d2 | ... | dk |
| | Decimal | 27 | 29 | 47 | 52 | nL | nH | d1 | d2 | ... | dk |

[Defined Area] Thermal : $1 \leq nL \leq 64$, $nH = 0$
 $1 \leq (nL + nH \times 256) \leq 64$
 $dk = (nL + nH \times 256)$
 $0 \leq d \leq 255$

Slip : -

Validation : -

[Initial Value] Thermal : No user macro 2 setting

Slip : -

Validation : -

[Function]

<Thermal>

Sets user macro 2 for the Auto Logo function.

This setting is registered to non-volatile memory by the ESC GS / W command.

This command is ignored while Auto Logo is executing.

Registers print data in user macro 2.

Maximum 64 bytes of registered data

Note that registering Auto Logo command characters in the user macros is prohibited.

<Slip>, <Validation>

Only setting is valid

Setting is valid after switching to thermal.

ESC GS / 5 n

[Name] Set command character switching method

| | | | | | | |
|--------|-------------|-----|----|----|----|---|
| [Code] | ASCII | ESC | GS | / | 5 | n |
| | Hexadecimal | 1b | 1d | 2f | 35 | n |
| | Decimal | 27 | 29 | 47 | 53 | n |

[Defined Area] Thermal : $0 \leq n \leq 1$
 Slip : -
 Validation : -

[Initial Value] Thermal : $n = 0$
 Slip : -
 Validation : -

[Function]
 <Thermal>

Sets command character conversion method for the Auto Logo function.
 This setting is registered to non-volatile memory by the ESC GS / W command.
 This command is ignored while Auto Logo is executing.

| n | Setting |
|---|--|
| 0 | Does not print command character or logo number continuing after that. |
| 1 | Converts the command character and logo number that follows in a space character (0 x 20). |

If “/” is specified for the command character, the “/2” embedded in the print data is processed not as a character string but as a command.

At that time, “/2” is processed as a command so there is no print.

However, “/2” is converted to a space by the $n = 1$ specification of this command.

<Slip>, <Validation>

Only setting is valid

Setting is valid after switching to thermal.

ESC GS / 6 n

[Name] Partial cut setting just prior to Auto Logo printing

[Code] ASCII ESC GS / 6 n
 Hexadecimal 1b 1d 2f 36 n
 Decimal 27 29 47 54 n

[Defined Area] Thermal : 0 ≤ n ≤ 1
 Slip : -
 Validation : -

[Initial Value] Thermal : n = 0
 Slip : -
 Validation : -

[Function]
 <Thermal>

Sets the partial cut setting just prior to Auto Logo printing
 This setting is registered to non-volatile memory by the ESC GS / W command.
 This command is ignored while Auto Logo is executing.

| n | Setting |
|---|---|
| 0 | Does not execute partial cut just prior to Auto Logo printing |
| 1 | Executes partial cut just prior to Auto Logo printing |

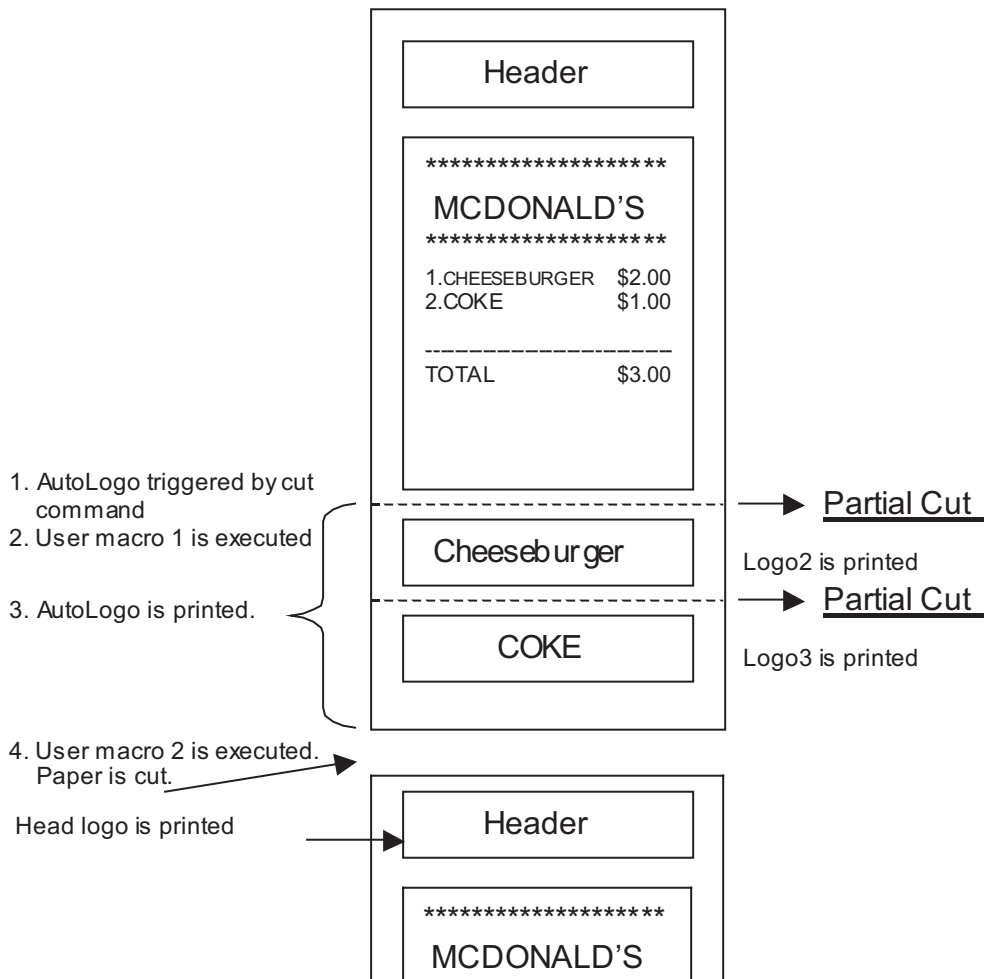

This command selects execution of a partial cut just prior to Auto Logo Logo 2, and Logo 3, when executing Logos 2 and 3 as an Auto Logo print, as shown above.

If a partial cut is set to be executed by this function, it is possible to supply coupons printed by Auto Logo cut by the partial cut.

<Slip>, <Validation>

Only setting is valid

Setting is valid after switching to thermal.

3-9) 2-dimensional Bar Codes PDF417 Command Details

This command prints 2-dimensional bar codes PDF417.

Commands for 2-dimensional bar codes PDF417 are separated into the following four functions.

- 1) Bar code type setting (`<ESC> <GS> "x" "S"`)
- 2) Bar code data setting (`<ESC> <GS> "x" "D"`)
- 3) Bar code printing (`<ESC> <GS> "x" "P"`)
- 4) Get bar code expansion information (`<ESC> <GS> "x" "I"`)

The details of the functions are outlined below.

1) Bar code type setting

These commands set the bar code type.

These are all set to default. Only use them if you wish to make changes. (Refer to following details for settings.)

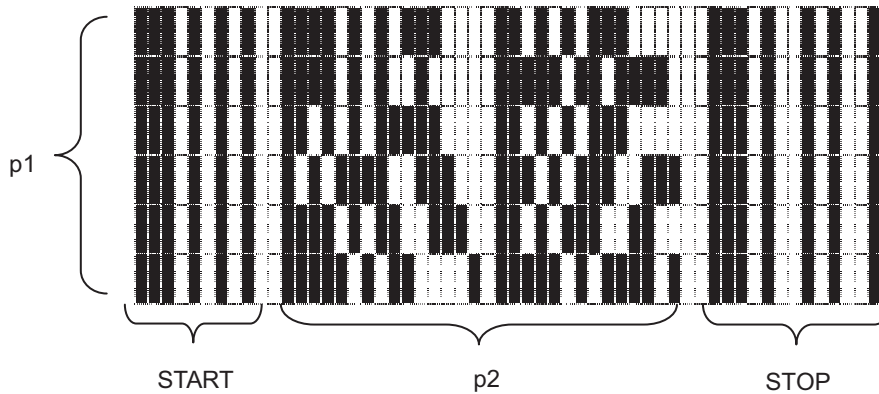

PDF417 are composed of fixed patterns for start and stop, and bar patterns called code words. Code words are composed of 17 modules.



Specify the p1 and p2 values using `<ESC> <GS> "x" "S" "0."`

With the USE_LIMITS mode, specify the ratio of p1 and p2; with the USE_FIXED mode, specify the p1 (number of lines) and p2 (number of code words per line).

Specify the error correction level value using `<ESC> <GS> "x" "S" "1."`

It is possible to read PDF417 even part of the data is corrupted, using error correction.

If this level is raised, the bar code size is increased because there is more backup information.

Specify the size of the module that composes code words using `<ESC> <GS> "x" "S" "2"` and `<ESC> <GS> "x" "S" "3."`

The X direction size of the module is determined by `<ESC> <GS> "x" "S" "2"` and the Y direction size of the module is determined from an aspect ratio using `<ESC> <GS> "x" "S" "3."`

The module size setting is the basis for the generated bar code image, so print results will differ according to these settings.

<Printable Bar Code Size>

| Vertical Size (Dots) | Horizontal Size (Dots) |
|----------------------|------------------------|
| 640 | 640 |

These are individual settings, so the following errors may occur even if there are no problems. In such cases, the bar code will not be generated, and the (3) print command ((`<ESC> <GS> "x" "P"`) will be ignored.

- An error occurs when generating the bar code by the combination of bar code settings.
- When the generated bar code exceeds the printable PDF417 size.
- When the print data exceeds the currently set print region.

It is recommended to use the (4) Get bar code expansion information command (`<ESC> <GS> "x" "I"`) as a means for checking for these errors prior to printing.

2) Bar code data setting command

This command set the bar code print data.

3) Bar code printing command

This command prints the bar codes based on the settings of (1) and (2).

4) Get bar code expansion information command

This command checks whether a bar code can be printed based on the settings of (1) and (2).

= Precautions When Using the Commands =

- For (1) and (2), the setting values are retained if the following operations are not applied.
- New setting command is sent.
- Initialize commands are sent (`<ESC> @`, `<CAN>`)
- Power is turned off.
- With regard to (3) and (4), send as needed.
- Printing
 - When printing, the horizontal tabs, absolute position specification, relative position specification, and position movement using position alignment are valid.
 - Upside down printing and 2-color printing are possible.
 - Bar codes to be printed should always be confirmed through an actual printout.

Lastly is a command transmission example.

(1) Bar code type setting

```
<ESC> <GS> "x" "S" "0" 0 2 3:   Sets bar code size to USE_LIMITS = 2:3
<ESC> <GS> "x" "S" "1" 3:       Sets ECC level to 3.
<ESC> <GS> "x" "S" "2" 3:       Sets module X direction size to 3 dots.
<ESC> <GS> "x" "S" "3" 3:       Sets module aspect ratio to 3.
```

(2) Bar code data setting

```
<ESC> <GS> "x" "D" 10 0 "0123456789":   Sets bar code data.
```

(3) Print bar code

To confirm printability using the current settings, confirm the bar code expansion information.

```
<ESC> <GS> "x" "I":   Confirms bar code expansion information.
<ESC> <GS> "x" "P":   Prints
```

ESC GS x S 0 n p1 p2

[Name] PDF417 bar code size setting

| | | | | | | | | | |
|--------|-------------|-----|----|-----|----|----|---|----|----|
| [Code] | ASCII | ESC | GS | x | S | 0 | n | p1 | p2 |
| | Hexadecimal | 1B | 1D | 78 | 53 | 30 | n | p1 | p2 |
| | Decimal | 27 | 29 | 120 | 83 | 48 | n | p1 | p2 |

[Defined Area] Thermal : n = 0, 1
 When n = 0 1 ≤ p1 ≤ 99, 1 ≤ p2 ≤ 99
 When n = 1 p1 = 0 or 3 ≤ p1 ≤ 90, p2 = 0 or 1 ≤ p2 ≤ 30 (However, this excludes p1 = p2 = 0.)
 Slip : -
 Validation : -
 [Initial Value] Thermal : n = 0, p1 = 1, p2 = 2
 Slip : -
 Validation : -

[Function]
 <Thermal>

Parameter details

| n (Bar Code Size Specification Method) | | p1, p2 (Size Specification) |
|---|--|---|
| 0 | USE_LIMITS (Specifies ratio of bar code vertical/horizontal directions) | p1: p2: Distribution ratio of vertical (p1) and horizontal (p2) However, p1: p2 = 1 : 99 to 10:1 (p1/p2 = 0.01 to 10) |
| 1 | USE_FIXED (Specifies number of lines, and number of columns in the bar code.) | p1: Number of lines (0, 3 to 90); p2: Number of columns (0, 1 to 30) However, p1 * p2 ≤ 928 If either p1 or p2 is set to 0, it indicates that that value is variable. |

Setting of the bar code size using this command specifies the general size. The size is automatically corrected by other settings.

<Slip>, <Validation>
 Only setting is valid
 Setting is valid after switching to thermal.

ESC GS x S 1 n

[Name] Set PDF417 ECC (security level)

| | | | | | | | |
|--------|-------------|-----|----|-----|----|----|---|
| [Code] | ASCII | ESC | GS | x | S | 1 | n |
| | Hexadecimal | 1B | 1D | 78 | 53 | 31 | n |
| | Decimal | 27 | 29 | 120 | 83 | 49 | n |

[Defined Area] Thermal : 0 ≤ n ≤ 8
 Slip : -
 Validation : -
 [Initial Value] Thermal : n = 1
 Slip : -
 Validation : -

[Function]
 <Thermal>

Parameter details

• n: : ECC level (0 to 8)

<Slip>, <Validation>
 Only setting is valid
 Setting is valid after switching to thermal.

ESC GS x S 2 n

[Name] Set PDF417 module X direction size

| | | | | | | | |
|--------|-------------|-----|----|-----|----|----|---|
| [Code] | ASCII | ESC | GS | x | S | 2 | n |
| | Hexadecimal | 1B | 1D | 78 | 53 | 32 | n |
| | Decimal | 27 | 29 | 120 | 83 | 50 | n |

[Defined Area] Thermal : $1 \leq n \leq 10$
 Slip : -
 Validation : -

[Initial Value] Thermal : $n = 2$
 Slip : -
 Validation : -

[Function]
 <Thermal>

Parameter details

- n : Sets the module X direction size (x-dim) (units: dots)
 Specification using this command is recommended to be $2 \leq n$.
 To use with $n = 1$, confirm by actual use.

<Slip>, <Validation>

- Only setting is valid
- Setting is valid after switching to thermal.

ESC GS x S 3 n

[Name] Set PDF417 module aspect ratio

| | | | | | | | |
|--------|-------------|-----|----|-----|----|----|---|
| [Code] | ASCII | ESC | GS | x | S | 3 | n |
| | Hexadecimal | 1B | 1D | 78 | 53 | 33 | n |
| | Decimal | 27 | 29 | 120 | 83 | 51 | n |

[Defined Area] Thermal : $1 \leq n \leq 10$
 Slip : -
 Validation : -

[Initial Value] Thermal : $n = 3$
 Slip : -
 Validation : -

[Function]
 <Thermal>

Parameter details

- n: Sets module aspect ratio (asp).
 The module Y direction size is set to $[x\text{-dim} * \text{asp}]$ by this command.
 Specification using this command is recommended to be $2 \leq n$.
 To use with $n = 1$, confirm by actual use.

<Slip>, <Validation>

- Only setting is valid
- Setting is valid after switching to thermal.

ESC GS x D nL nH d1 d2 ... dk

[Name] PDF417 bar code data setting

| | | | | | | | | | | | |
|--------|-------------|-----|----|-----|----|----|----|----|----|-----|----|
| [Code] | ASCII | ESC | GS | x | D | nL | nH | d1 | d2 | ... | dk |
| | Hexadecimal | 1B | 1D | 78 | 44 | nL | nH | d1 | d2 | ... | dk |
| | Decimal | 27 | 29 | 120 | 68 | nL | nH | d1 | d2 | ... | dk |

[Defined Area] Thermal : $0 \leq nL \leq 255, 0 \leq nH \leq 255$
 $1 \leq (nL + nH \times 256) \leq 1024$
 $0 \leq d \leq 255, 1 \leq k \leq 1024$

Slip : -

Validation : -

[Initial Value] Thermal : -

Slip : -

Validation : -

[Function]

<Thermal>

Parameter details

- nL+nH×256: Bar code data count
- dk: Bar code data (max. 1024 data)

When [nL+nH×256] is outside of the defined area, data of [nL+nH×256] bytes is received and discarded.

<Slip>, <Validation>

Only setting is valid

Setting is valid after switching to thermal.

ESC GS x P

[Name] Print PDF417 bar code

| | | | | | |
|--------|-------------|-----|----|-----|----|
| [Code] | ASCII | ESC | GS | x | P |
| | Hexadecimal | 1B | 1D | 78 | 50 |
| | Decimal | 27 | 29 | 120 | 80 |

[Defined Area] Thermal : -

Slip : -

Validation : -

[Initial Value] Thermal : -

Slip : -

Validation : -

[Function]

<Thermal>

Prints bar code data.

If there is unprinted data in the line buffer, this command is executed after printing that data.

Therefore, it is not possible to print with other data in the same line (characters, bit images, bar codes).

Also, if the following errors occur, this command is ignored.

- An error occurs when generating the bar code by the combination of bar code settings.
- When the generated bar code exceeds the printable PDF417 size.
- When the print data exceeds the currently set print region.
- Bar codes to be printed should always be confirmed through an actual printout.

<Slip>, <Validation>

Four bytes ignored

ESC GS x I

[Name] Get PDF417 bar code expansion information

| | | | | | |
|--------|-------------|-----|----|-----|----|
| [Code] | ASCII | ESC | GS | x | I |
| | Hexadecimal | 1B | 1D | 78 | 49 |
| | Decimal | 27 | 29 | 120 | 73 |

[Defined Area] Thermal : -
 Slip : -
 Validation : -

[Initial Value] Thermal : -
 Slip : -
 Validation : -

[Function]
 <Thermal>

In printing bar codes with the current setting and the printing starting position using this command, information such as the presence of errors is sent to the printer.

Therefore, it is possible to confirm whether printing is possible before actual printing, with this command.

If there is an error, the command is received and discarded even if the print command ESC GS x P is sent.

Also, if the following errors occur, "Error" information is sent to the printer.

- When an error occurs when generating the bar code by the combination of bar code settings
- When the generated bar code exceeds the printable PDF417 size.
- When the print data exceeds the currently set print region.

Transmission format: <ESC> <GS> "x" "I" n

| | |
|---|-------|
| n | |
| 0 | No |
| 1 | Error |

<Slip>, <Validation>

Send <ESC> <GS> "x" "I" 1 (error)

3-10) Print Starting Trigger Control Command Details

This command is for models equipped with an expansion control function that page-controls the command in line units by page-controlling the image buffer.

ESC GS g 0 m n

| | | | | | | | |
|--------|------------------------|-----|----|-----|----|---|---|
| [Name] | Print starting trigger | | | | | | |
| [Code] | ASCII | ESC | GS | g | 0 | m | n |
| | Hexadecimal | 1B | 1D | 67 | 30 | m | n |
| | Decimal | 27 | 29 | 103 | 48 | m | n |

| | | | |
|-----------------|------------|---|--------------|
| [Defined Area] | Thermal | : | m = 0, n = 0 |
| | Slip | : | - |
| | Validation | : | - |
| [Initial Value] | Thermal | : | - |
| | Slip | : | - |
| | Validation | : | - |

[Function]
<Thermal>

Starts printing if there is unprinted data in the image buffer.
Transmission of this command is prohibited when in raster mode.

<Slip>, <Validation>
Six bytes ignored

ESC GS g 1 m n

| | | | | | | | |
|--------|-----------------------|-----|----|-----|----|---|---|
| [Name] | Set print start timer | | | | | | |
| [Code] | ASCII | ESC | GS | g | 1 | m | n |
| | Hexadecimal | 1B | 1D | 67 | 31 | m | n |
| | Decimal | 27 | 29 | 103 | 49 | m | n |

| | | | |
|-----------------|------------|---|-----------------------|
| [Defined Area] | Thermal | : | m = 0, 0 ≤ n ≤ 255 |
| | Slip | : | - |
| | Validation | : | - |
| [Initial Value] | Thermal | : | See the models below. |
| | Slip | : | - |
| | Validation | : | - |

[Function]
<Thermal>

Sets the print starting timer specified by n x 10 msec.
The print starting timer starts measuring from the point where the reception of print data stops, up to the set printing starting time.
When the set print starting time is reached, this starts printing if there is unprinted data in the image buffer.
Transmission of this command is prohibited when in raster mode.

| n | Operating Mode |
|----------|-----------------------------------|
| 0 | Print start timer = default value |
| 1 to 255 | Print start timer = n x 10 msec |

<Slip>, <Validation>
Only setting is valid
Setting is valid after switching to thermal.

3-11) 2-dimensional Bar Codes QR Code Command Details

* QR code is a registered trademark of DENSO WAVE Incorporated.

This command prints 2-dimensional bar codes of QR code.

Commands for 2-dimensional bar codes QR code are separated into the following four functions.

- 1) Bar code type setting (<ESC> <GS> "y" "S")
- 2) Bar code data setting (<ESC> <GS> "y" "D")
- 3) Page mode setting (Reserved)
- 4) Bar code printing (<ESC> <GS> "y" "P")
- 5) Get bar code expansion information (<ESC> <GS> "y" "I")

The details of the functions are outlined below.

1) Bar code type setting

These commands set the bar code type.

These are all set to default. Only use them if you wish to change them. (Refer to following details for settings.)

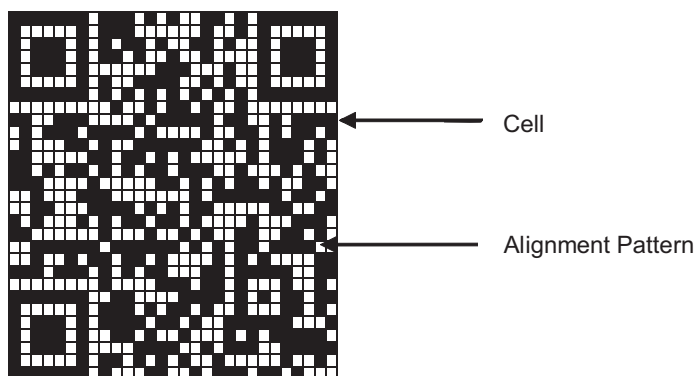

Specify model using <ESC> <GS> "y" "S" "0."

Currently supported models are model 1 and model 2. To improve tolerance to distortion when codes are large on model 2, an alignment pattern has been added to the structure.

Specify the error correction level using <ESC> <GS> "y" "S" "1."

It is possible to read QR code even part of the data is corrupted, using error correction.

If this level is raised, the bar code size is increased because there is more backup information.

Specify the size of the cell (one square region that composes the QR code) using <ESC> <GS> "y" "S" "2."

The vertical and horizontal sizes for the QR code are equal length squares, but the size of the bar code image generated is determined by the cell size.

See Appendix 7 for details on the actual printed QR code size.

These are individual settings, so the following errors may occur even if there are no problems. In such cases, the bar code will not be generated, and the (4) print command ((<ESC> <GS> "y" "P") will be ignored, and an error code will be returned with (5) get bar code expansion information.

- An error occurs when generating the bar code by the combination of settings.
- When the print data exceeds the currently set print region.

Therefore, it is recommended to use the (5) Get bar code expansion information command (<ESC> <GS> "y" "I") as a means for checking for these errors prior to printing.

2) Bar code data setting command

This command set the bar code print data.

There are four types of data types that can be set by the QR code. They are: numbers, alpha-numeric characters, binary and Kanji characters. However, with these specifications, there are two data setting methods. They are: A method that specifies that data along with the bar code data (data manual analysis); and a method that specifies only the bar code data (data automatic analysis).

(3) Page mode setting command

This command is not used.

4) Bar code printing command

This command prints the bar codes based on the settings of (1) and (3).

5) Get bar code expansion information command

This command checks whether a bar code can be printed based on the settings of (1) to (3).

= Precautions When Using the Commands =

- For (1) to (3), the setting values are retained if the following operations are not applied.
- New setting command is sent.
- Initialize commands are sent (<ESC> @, <CAN>)
- Power is turned off.
- With regard to (2), when an error occurs in command transmission, the set data is cleared, and the command is invalid.
- With regard to (4) and (5), send as needed.
- Printing
- When printing, the horizontal tabs, absolute position specification, relative position specification, and position movement using position alignment are valid.
- Upside down printing and 2-color printing are possible.
- Bar codes to be printed should always be confirmed through an actual printout.

Below is a command transmission example.

(1) Bar code type setting

<ESC> <GS> "y" "S" "0" 1 : Set to model 1.
<ESC> <GS> "y" "S" "1" 0 : Set error correction level to L.
<ESC> <GS> "y" "S" "2" 3 : Set cell size to 3 dots.

2) Bar code data setting

• <ESC> <GS> "y" "D" "1" 0 20 0 "2005, January 1 (SAT)" <LF>
: Set bar code data (data automatic analysis)
• <ESC> <GS> "y" "D" "2" 10 1 4 0 "2005", " : Set bar code data (data manual analysis)
4 2 0 "Year" " ,"
1 1 0 "1" " ,"
4 2 0 "Month" " ,"
1 1 0 "1" " ,"
4 2 0 "Day" " ,"
4 2 0 "(" " ,"
2 3 0 "SAT" " ,"
4 2 0 ")" " ,"
3 1 0 <LF>

(3) Print bar code

To confirm printability using the current settings, confirm the bar code expansion information.

<ESC> <GS> "y" "1" : Confirms bar code expansion information.
<ESC> <GS> "y" "P" : Prints

ESC GS y S 0 n

[Name] Set QR code model

[Code] ASCII ESC GS y S 0 n
 Hexadecimal 1B 1D 79 53 30 n
 Decimal 27 29 121 83 48 n

[Defined Area] Thermal : 1 ≤ n ≤ 2
 Slip : -
 Validation : -

[Initial Value] Thermal : n = 2
 Slip : -
 Validation : -

[Function]
 <Thermal>

Sets the model.
 • Parameter details

| n | Set model |
|---|-----------|
| 1 | Model 1 |
| 2 | Model 2 |

<Slip>, <Validation>

Only setting is valid
 Setting is valid after switching to thermal.

ESC GS y S 1 n

[Name] Set QR code mistake correction level

[Code] ASCII ESC GS Y S 1 n
 Hexadecimal 1B 1D 79 53 31 n
 Decimal 27 29 121 83 49 n

[Defined Area] Thermal : 0 ≤ n ≤ 3
 Slip : -
 Validation : -

[Initial Value] Thermal : n = 0
 Slip : -
 Validation : -

[Function]
 <Thermal>

Sets the error correction level.
 • Parameter details

| n | Error Correction Level | Error Correction Rate (%) |
|---|------------------------|---------------------------|
| 0 | L | 7 |
| 1 | M | 15 |
| 2 | Q | 25 |
| 3 | H | 30 |

<Slip>, <Validation>

Only setting is valid
 Setting is valid after switching to thermal.

ESC GS y S 2 n

[Name] Set QR code cell size

| | | | | | | | |
|--------|-------------|-----|----|-----|----|----|---|
| [Code] | ASCII | ESC | GS | y | S | 2 | n |
| | Hexadecimal | 1B | 1D | 79 | 53 | 32 | n |
| | Decimal | 27 | 29 | 121 | 83 | 50 | n |

[Defined Area] Thermal : $1 \leq n \leq 8$
 Slip : -
 Validation : -

[Initial Value] Thermal : $n = 3$
 Slip : -
 Validation : -

[Function]

<Thermal>

Sets the cell size.

- Parameter details
- n: Cell size (Units: Dots)
- Specification using this command is recommended to be $3 \leq n$.
 To use with $n = 1$ and 2 , confirm by actual use.

<Slip>, <Validation>

Only setting is valid

Setting is valid after switching to thermal.

ESC GS y D 1 m nL nH d1 d2 ... dk

[Name] QR code data setting (automatic setting)

| | | | | | | | | | | | | | |
|--------|-------------|-----|----|-----|----|----|---|----|----|----|----|-----|----|
| [Code] | ASCII | ESC | GS | y | D | 1 | m | nL | nH | d1 | d2 | ... | dk |
| | Hexadecimal | 1B | 1D | 79 | 44 | 31 | m | nL | nH | d1 | d2 | ... | dk |
| | Decimal | 27 | 29 | 121 | 68 | 49 | m | nL | nH | d1 | d2 | ... | dk |

| | | | |
|-----------------|------------|---|---|
| [Defined Area] | Thermal | : | m = 0 |
| | | | $0 \leq nL \leq 255, 0 \leq nH \leq 255 \quad 1 \leq nL + nH \times 256 \leq 7089 \quad (k = nL + nH \times 256)$ |
| | | | $0 \leq d \leq 255$ |
| | Slip | : | - |
| | Validation | : | - |
| [Initial Value] | Thermal | : | - |
| | Slip | : | - |
| | Validation | : | - |

[Function]
<Thermal>

Automatically analyzes the bar code data type and sets the data.

- Parameter details
- nL+nH×256: Bar code data byte count
- dk: Bar code data (max. 7089 bytes)
- When using this command, the printer receives data of the number of bytes (k) specified by nL and nH, automatically analyzes the data and sets that as the bar code data.
- nL and nH specify the number of data bytes.
When processed as a Kanji character code, two bytes are one character.
- If the parameter is outside of the defined area, the data for the amount of the counter is received and discarded.
At that time, the bar code data is not cleared.
- The command data storage region is shared with the manual setting command, so data is updated each time either command is executed.

<Slip>, <Validation>

Only setting is valid
Setting is valid after switching to thermal.

ESC GS y D 2 a m1 n1L n1H d11 d12 ... d1k m2 n2L n2H d21 d22 ... d2k ml ... dlk

[Name] QR code data setting (manual setting)

| | | | | | | | | | | | | | | |
|--------|-------------|-----|-----|-----|-----|-----|-----|-----|-----|-----|-----|-----|-----|-----|
| [Code] | ASCII | ESC | GS | y | D | 2 | a | m1 | n1L | n1H | d11 | d12 | ... | d1k |
| | Hexadecimal | 1B | 1D | 79 | 44 | 32 | a | m1 | n1L | n1H | d11 | d12 | ... | d1k |
| | Decimal | 27 | 29 | 121 | 68 | 50 | a | m1 | n1L | n1H | d11 | d12 | ... | d1k |
| | ASCII | m2 | n2L | n2H | D21 | d22 | ... | d2k | ml | ... | dlk | | | |
| | Hexadecimal | m2 | n2L | n2H | D21 | d22 | ... | d2k | ml | ... | dlk | | | |
| | Decimal | m2 | n2L | n2H | D21 | d22 | ... | d2k | ml | ... | dlk | | | |

[Defined Area] Thermal : $1 \leq a \leq 255$
 $1 \leq m \leq 4$
 $0 \leq nL \leq 255, 0 \leq nH \leq 255 \quad 1 \leq nL + nH \times 256 \leq 7089 \quad (k = nL + nH \times 256)$
 $0 \leq d \leq 255$
 $1 \leq l \leq 255$

Slip : -

Validation : -

[Initial Value] Thermal : -

Slip : -

Validation : -

[Function]

<Thermal>

Specifies the bar code data type and sets the data.

- Parameter details
- a : Block count
- m : Input data type
- nL + nH x 256 : Bar code data byte count
- dk : Bar code data (max. 7089 bytes)

| m | Data Type | Data Defined Area (d) |
|---|------------------------------|---|
| 1 | Numbers | "0" to "9" |
| 2 | English Language Characters | " ", "\$", "%", "*", "+", "-", ".", "/", ":", "0" to "9", "A" to "Z" |
| 3 | Binary | 0x00 to 0xFF |
| 4 | Kanji characters (Shift JIS) | 0x8140 to 0x9FFC, 0xE040 to 0xEBBF However, the lower 8 bits are 0x40 to 0x7E, 0x80 to 0xFC. |

- The printer receives the data type specified by m, based on the block count specified by a, and the data of the number of bytes (k) specified by nL and nH, and sets that as the bar code data.
- One block specified by a specifies m1 n1L n1H d11...d1k (data type + data count + bar code data), and by sending a multiple of these continuously, data types can be included in one bar code.
- It is possible to set a maximum of 255 blocks with one command transmission.
- nL and nH specify the number of data bytes, so for Kanji characters, calculation is done using 1 character for two bytes.
- If the parameter is outside of the defined area, the data for the amount of the counter is received and discarded.
At that time, the bar code data is cleared.
- The command data storage region is shared with the automatic setting command, so data is updated each time either command is executed.

<Slip>, <Validation>

Only setting is valid

Setting is valid after switching to thermal.

ESC GS y P

[Name] Print QR code

| | | | | | |
|--------|-------------|-----|----|-----|----|
| [Code] | ASCII | ESC | GS | y | P |
| | Hexadecimal | 1B | 1D | 79 | 50 |
| | Decimal | 27 | 29 | 121 | 80 |

[Defined Area] Thermal : -
Slip : -
Validation : -

[Initial Value] Thermal : -
Slip : -
Validation : -

[Function]
<Thermal>

This command prints the bar code data.

When this command is received, the printer prints unprinted data, if unprinted data remains in the image buffer, then prints the bar code.

Margins of more than 4 cells are required around the QR code. The user must ensure the margins.

- Bar codes to be printed should always be confirmed through an actual printout.

<Slip>, <Validation>

Four bytes ignored

ESC GS y I

[Name] Get QR code expansion information

| | | | | | |
|--------|-------------|-----|----|-----|----|
| [Code] | ASCII | ESC | GS | y | I |
| | Hexadecimal | 1B | 1D | 79 | 49 |
| | Decimal | 27 | 29 | 121 | 73 |

[Defined Area] Thermal : -
Slip : -
Validation : -

[Initial Value] Thermal : -
Slip : -
Validation : -

[Function]
<Thermal>

In expanding bar codes with the current setting using this command, information such as the size of the generated image and errors is sent to the printer.

Therefore, it is possible to confirm whether printing is possible before actual printing, with this command.

If there is an error in the bar code expansion, the command is ignored even if the expansion command ESC GS y P is sent.

Also, if the following errors occur, "Error" information is sent to the printer.

- When an error occurs when generating the bar code by the combination of bar code settings
- When the generated bar code exceeds the printable size.

Transmission format: <ESC> <GS> "y" "I" n1 n2

| n1 n2 | Bar Code Information |
|------------------|---|
| 0x0000 | Error |
| 0x0001 to 0xffff | Size of one side of generated bar code data (Units: Dots) |

<Slip>, <Validation>

Send <ESC> <GS> "y" "I" 0 0 (error)

3-12) Page Function Command Details

ESC GS h 0 k m n

[Name] 180° inversion function

| | | | | | | | | |
|--------|-------------|-----|----|-----|----|---|---|---|
| [Code] | ASCII | ESC | GS | h | 0 | k | m | n |
| | Hexadecimal | 1B | 1D | 68 | 30 | k | m | n |
| | Decimal | 27 | 29 | 104 | 48 | k | m | n |

[Defined Area] Thermal : $0 \leq k \leq 1, m = 0, n = 0$
 Slip : -
 Validation : -
 [Initial Value] Thermal : -
 Slip : -
 Validation : -

[Function]
 <Thermal>

Sets to make 180° inversion function valid/invalid.

| k | 180° Inversion Function |
|---|-------------------------|
| 0 | Invalid |
| 1 | Valid |

<180° Inversion Function>

When the 180° inversion function is valid, it is executed by the 180° inversion trigger. However, this function is executed on print data that fits in the image buffer length. If print data is larger than the image buffer length, the 180° inversion function is ignored. Also, when starting printing using anything other than the 180° inversion trigger, the 180° inversion function is ignored. This setting is not cleared by the ESC @, CAN commands.

180° Inversion Triggers

- Cutter Command: ESC d n
- FF Command: FF
- BM Detection Command: ESC d n, FF
- Print Startup Command: ESC GS g 0 m n
- Raster Mode: When executing FF

Example of Use

- *1) 180° Inversion Function Valid: ESC GS h 0 k m n (k=0x01, m=0x00, n=0x00)
- 2) Transmit print data: Print data (print length is within the length of the image buffer)
- 3) Trigger command transmission: ESC d n (cutter command is 180° inversion trigger)

<Slip>, <Validation>

Only setting is valid
 Setting is valid after switching to thermal.

(Note) When using this function, the data volume for one page should be within the printer's buffer length.

ESC GS h 1 k m n

[Name] Water mark function

[Code] ASCII ESC GS h 1 k m n
 Hexadecimal 1B 1D 68 31 k m n
 Decimal 27 29 104 49 k m n

[Defined Area] Thermal : 0 ≤ k ≤ 2, 0 ≤ m ≤ 2, 1 ≤ n ≤ 255
 Slip : -
 Validation : -

[Initial Value] Thermal : -
 Slip : -
 Validation : -

[Function]
 <Thermal>

Sets to make water mark function valid/invalid.

| k | Water Mark Function |
|---|---|
| 0 | Invalid |
| 1 | Valid Prints one logo specified by n at the position centered in the horizontal and vertical directions. |
| 2 | Valid Repeatedly prints logo specified by n from leading edge of the page to the trailing end of the page, at the position centered in the horizontal direction. |

Set the forming method of the logo data to be printed as the water mark to make the image appropriate as the water mark with this setting.
 If the appropriate image is not possible with this setting, re-register after forming the logo data registered as the water mark as the appropriate data.

| m | Water Mark Data Forming |
|---|--|
| 0 | Prints logo data specified n as it is. |
| 1 | Thins logo data specified n 25% in the printout. |
| 2 | Thins logo data specified n 12.5% in the printout. |

Specify the registered logo as the water mark.

| n | Logo Number |
|----------|---|
| 1 to 255 | Registered logo number If the specified logo number is not registered, the water mark will not be printed. |

<Water Mark Function>

When the water mark inversion function is valid, it is printed by the water mark pinting trigger. However, this function is executed on print data that fits in the image buffer length. If print data is larger than the image buffer length, water mark printing is ignored. Also, when starting printing using anything other than the water mark printing trigger, water mark printing is ignored.
 When in 2-color printing mode, this function is invalid.
 This setting is not cleared by the ESC @, CAN commands.

Water Mark Printing Triggers

- Cutter Command : ESC d n
- FF Command : FF
- BM Detection Command : ESC d n, FF
- Print Startup Command : ESC GS g 0 m n
- Raster Mode : When executing FF

Example of Use

- 1) Register logo to use as the water mark as logo #1.
- 2) Water mark function is valid.: ESC GS h 1 k m n (k=0x02, m=0x01, n=0x01)
- 3) Transmit print data: Print data (print length is within the length of the image buffer)
- 4) Trigger command transmission: ESC d n (cutter command is water mark printing trigger)

<Slip>, <Validation>

Only setting is valid

Setting is valid after switching to thermal.

(Note) When using this function, the data volume for one page should be within the printer's buffer length.

3-13) Slip/Validation Function Command Details

ESC SI n

[Name] Set slip sensor
 [Code] ASCII ESC SI n
 Hexadecimal 1B 0F n
 Decimal 27 15 n

[Defined Area] Thermal : -
 Slip : -
 Validation : -
 [Initial Value] Thermal : -
 Slip : -
 Validation : -

[Function]
 Three bytes ignored

ESC FF n

[Name] Slip/Validation Function
 [Code] ASCII ESC FF n
 Hexadecimal 1B 0C n
 Decimal 27 12 n

[Defined Area] Thermal : -
 Slip : $2 \leq n \leq 5, 50 \leq n \leq 53, ("2" \leq n \leq "5")$
 Validation : $2 \leq n \leq 5, 50 \leq n \leq 53, ("2" \leq n \leq "5")$
 [Initial Value] Thermal : -
 Slip : -
 Validation : -

[Function]
 <Thermal>
 Three bytes ignored

<Slip>
 After printing data in the line buffer, the slip paper operation is executed according to the n value.

| n | Slip Operation |
|----------|--|
| 2 to 5 | Discharges paper toward the back (the forward direction) |
| 50 to 53 | |

<Validation>
 After printing data in the line buffer, the validation printer operation is executed according to the n value.

| n | Slip Operation |
|----------|--|
| 2 to 5 | Discharges paper toward the back (the forward direction) |
| 50 to 53 | |

ESC VT m n

[Name] Sets slip paper discharge direction and discharge length

| | | | | | |
|--------|-------------|-----|----|---|---|
| [Code] | ASCII | ESC | VT | m | n |
| | Hexadecimal | 1B | 0B | m | n |
| | Decimal | 27 | 11 | m | n |

| | | | |
|-----------------|------------|---|---|
| [Defined Area] | Thermal | : | - |
| | Slip | : | - |
| | Validation | : | - |
| [Initial Value] | Thermal | : | - |
| | Slip | : | - |
| | Validation | : | - |

[Function] Four bytes ignored

ESC EM n m LF NUL

[Name] Set slip/validation automatic clamp

| | | | | | | | |
|--------|-------------|-----|----|---|---|----|-----|
| [Code] | ASCII | ESC | EM | n | M | LF | NUL |
| | Hexadecimal | 1B | 19 | n | M | 0A | 00 |
| | Decimal | 27 | 25 | n | M | 10 | 0 |

| | | | |
|-----------------|------------|---|---------------------------------|
| [Defined Area] | Thermal | : | - |
| | Slip | : | 0 ≤ n ≤ 255 m = 0, 1, 48, 49 |
| | Validation | : | 0 ≤ n ≤ 255 m = 2, 3, 50, 51 |
| [Initial Value] | Thermal | : | - |
| | Slip | : | n: MSW Setting m = 0 |
| | Validation | : | n: MSW Setting m = 0 |

[Function]

| m | Function |
|--------------|---|
| 0, 1, 48, 49 | Sets the waiting time from inserting slip paper until the start of execution of automatic clamp according to n. n is the same as the MSW slip opening time setting (for details refer to the MSW settings for each printer). |
| 2, 3, 50, 51 | Sets the waiting time from inserting validation paper until the start of execution of automatic clamp according to n. n is the same as the MSW validation opening time setting (for details refer to the MSW settings for each printer). |

<Thermal> Only setting is valid. Setting is valid after switching to slip or validation.

3-14) Page Mode Command Details

FF

[Name] Batch printing of page data (valid only in page mode)
 [Code] ASCII FF
 Hexadecimal 0C
 Decimal 12

[Defined Area] Thermal : -
 Slip : -
 Validation : -
 [Initial Value] Thermal : -
 Slip : -
 Validation : -

[Function]
 <Thermal>

Refer to "Page Control Command."

<Slip>, <Validation>

When in page mode, the printer batch prints page data expanded in the page region, then returns to line mode.

After batch printing of the page mode, data in the page, the page print region and print direction are all initialized.

Note that when the printer is in line mode, nothing functions.

ESC n

[Name] Selects page mode

| | | | |
|--------|-------------|-----|-----|
| [Code] | ASCII | ESC | n |
| | Hexadecimal | 1B | 6E |
| | Decimal | 27 | 110 |

| | | | |
|----------------|------------|---|---|
| [Defined Area] | Thermal | : | - |
| | Slip | : | - |
| | Validation | : | - |

| | | | |
|-----------------|------------|---|---|
| [Initial Value] | Thermal | : | - |
| | Slip | : | - |
| | Validation | : | - |

[Function]

<Thermal>

Two bytes ignored

<Slip>, <Validation>

Shifts from line mode (default) to page mode.

This command is valid when input at the top of the line. Page mode expands print data to the page coordinate region set by ESC * ... and according to the rotation direction set by ESC T n, and prints all the data using FF in the end.

In page mode, print data is OR expanded to the page region so you can be free to overlappingly write characters and bit images and rotate characters.

In page mode, if print data + <LF> is set using the same method as line mode, the data will be automatically rotated at the printer.

Page mode has the following restrictions.

(1) Print Data Expansion

In page mode, because data is expanded in normal dot increments, characters accompanying half dots cannot be handled.

When page mode is entered, ANK fonts are automatically set to 5 x 9 (2P-1) fonts.

In page mode, the IBM block is changed to vertical 8 dot fonts.

Kanji characters (Kanji) cannot be printed.

When the character space is an odd number, 1 half dot is discarded.

Also, characters are expanded based on the base line, so vertical double tall expanded characters are cut when the top portion is at the page top line, and if they are at the second line, they sometimes can overlap the previous line.

For that reason, if vertical expanded characters are included in one line, add an extra <LF> prior to the print data line to ensure print region to allow the vertical expanded character to be printed.

(2) Paper feed command

In page mode, the paper feed command and line feed are executed as a movement of the expanded position, according to dot units.

The 1 coordinate for the X direction is 0.159 mm (1 half-dot), and the 1 coordinate for the Y direction is 0.176 mm (1 half-dot) as the units of the X and Y coordinates. The printing results will not be doubled in the X and Y directions for 0°/180° rotations and 90°/270° rotations.

With 90°/270° rotations, the amount of paper feed and the height of the characters are reduced.

The font horizontal expansion and horizontal movement amounts are increased.

For example, when using 1/6 inch line feed with 0° rotation, 24 half-dots x 0.176 mm = 4.224 mm. However, with 90°/270° rotations, 24 half-dots x 0.159 mm = 3.816 mm. There is a difference of 4.224 - 3.816 = 0.408 mm.

To rotate a check print of a determined form 90° or 270°, create a program that considers this difference.

(3) • Setting Commands Received While in Page Mode

The following outlines three cases. (See each command for details.)

- Valid Command
- Commands that are valid when line mode is selected
- Ignored commands

Batch printing of page region data is executed by FF. After the FF, the printer returns to line mode. When returning to line mode, all conditions such as print data in the print region, region coordinate information, and rotation direction are cleared.

ESC !

[Name] Select line mode (Default)

| | | | |
|--------|-------------|-----|----|
| [Code] | ASCII | ESC | ! |
| | Hexadecimal | 1B | 21 |
| | Decimal | 27 | 33 |

[Defined Area] Thermal : -
 Slip : -
 Validation : -

[Initial Value] Thermal : -
 Slip : -
 Validation : -

[Function]

<Thermal>

Two bytes ignored

<Slip>, <Validation>

Select line mode (Default)

When this command is executed in page mode, the printer returns to line mode without printing.

When returning to line mode, all conditions such as print data in the print region, region coordinate information, and rotation direction are cleared.

ESC * xL xH yL yH dxL dxH dyL dyH

[Name] Set page mode print region

| | | | | | | | | | | | |
|--------|-------------|-----|----|----|----|----|----|-----|-----|-----|-----|
| [Code] | ASCII | ESC | * | xL | xH | yL | yH | dxL | dxH | dyL | dyH |
| | Hexadecimal | 1B | 2A | xL | xH | yL | yH | dxL | dxH | dyL | dyH |
| | Decimal | 27 | 42 | xL | xH | yL | yH | dxL | dxH | dyL | dyH |

| | | | |
|-----------------|------------|---|---|
| [Defined Area] | Thermal | : | - |
| | Slip | : | $0 \leq xL \leq 255, 0 \leq xH \leq 2$ $0 \leq yL \leq 255, 0 \leq yH \leq 5$ $0 \leq dxL \leq 255, 0 \leq dxH \leq 2$ (However, $0 \neq dxL + dxH \times 256$) $1 \leq dx \leq 540$ half-dots $0 \leq dyL \leq 255, 0 \leq dyH \leq 5$ (However, $0 \neq dyL + dyH \times 256$) $1 \leq dy \leq 1408$ half-dots |
| | Validation | : | $0 \leq xL \leq 255, 0 \leq xH \leq 2$ $0 \leq yL \leq 255, 0 \leq yH \leq 5$ $0 \leq dxL \leq 255, 0 \leq dxH \leq 2$ (However, $0 \neq dxL + dxH \times 256$) $1 \leq dx \leq 540$ half-dots $0 \leq dyL \leq 255, 0 \leq dyH \leq 5$ (However, $0 \neq dyL + dyH \times 256$) $1 \leq dy \leq 1408$ half-dots |
| [Initial Value] | Thermal | : | - |
| | Slip | : | $xL = 0, xH = 0, yL = 0, yH = 0, dxL = 28, dxH = 2, dyL = 128, dyH = 5$ $(X_0 = 0, Y_0 = 0, dx = 540, dy = 1408)$ |
| | Validation | : | $xL = 0, xH = 0, yL = 0, yH = 0, dxL = 28, dxH = 2, dyL = 128, dyH = 5$ $(X_0 = 0, Y_0 = 0, dx = 540, dy = 1408)$ |

[Function]
<Thermal>

The following commands are valid only when slip/validation have been selected. Their use is prohibited when thermal has been selected.

<Slip>, <Validation>

Set page mode print region

Use the left edge coordinate of the current position when the printer enters page mode as (0,0), and specify the starting point (X₀, Y₀) of the page region using xLxH,yLyH, and specify the length dx of the X direction using dxL, dxH, and the length dY of the Y direction using dyL, dyH.

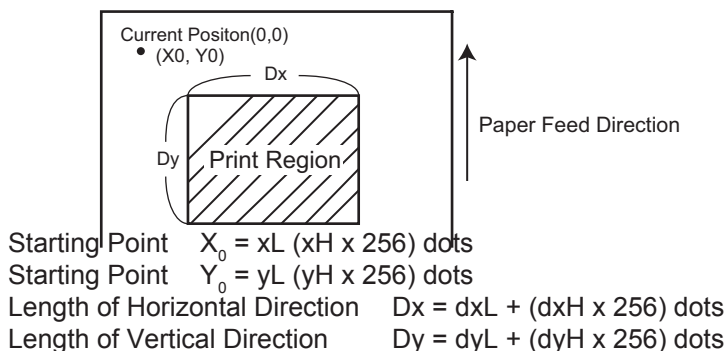

If the parameter is out of range, this command is invalid.

This command is stored even in line mode. However, the position when the printer enters page mode is applied for the reference point (0,0). Expansion of print data into the page is performed using the bottom edge of the characters as the base line, so a print region higher than the minimum of 9 dots is necessary for the height direction of the characters. (When using vertical double tall expanded characters, it is necessary to execute an extra paper feed in advance.)

ESC T n

[Name] Set page mode rotation direction

| | | | | |
|--------|-------------|-----|----|---|
| [Code] | ASCII | ESC | T | n |
| | Hexadecimal | 1B | 54 | n |
| | Decimal | 27 | 84 | n |

[Defined Area] Thermal : -
 Slip : $0 \leq n \leq 3, 48 \leq n \leq 51, ("0" \leq n \leq "3")$
 Validation : $0 \leq n \leq 3, 48 \leq n \leq 51, ("0" \leq n \leq "3")$

[Initial Value] Thermal : -
 Slip : n = 0
 Validation : n = 0

[Function]
 <Thermal>

Three bytes ignored

<Slip>, <Validation>

Sets the rotation in page mode to the items in the table below, according to the n value.
 Setting valid only when line mode.

| n | Rotation Direction |
|-------|--------------------|
| 0, 48 | 0° |
| 1, 49 | 270° |
| 2, 50 | 180° |
| 3, 51 | 90° |

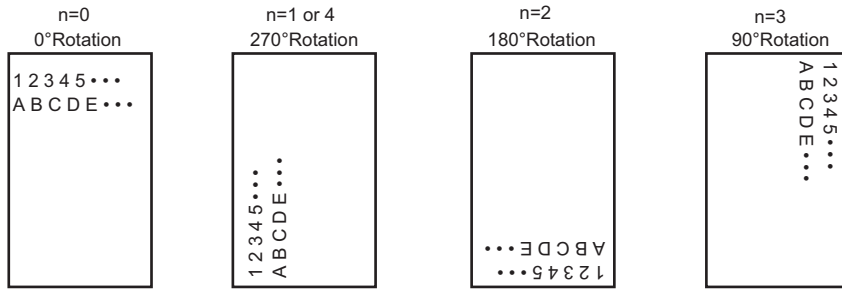

<Genend Concept of Rotation Diection>

3-15) Station Selection Command Details

ESC + A n

[Name] Select printer station

| | | | | | |
|--------|-------------|-----|----|----|---|
| [Code] | ASCII | ESC | + | A | n |
| | Hexadecimal | 1B | 2B | 41 | n |
| | Decimal | 27 | 43 | 65 | n |

| | | | |
|----------------|------------|---|----------------------------|
| [Defined Area] | Thermal | : | n = 0, 3, 4, "0", "3", "4" |
| | Slip | : | n = 0, 3, 4, "0", "3", "4" |
| | Validation | : | n = 0, 3, 4, "0", "3", "4" |

| | | | |
|-----------------|------------|---|-------|
| [Initial Value] | Thermal | : | n = 0 |
| | Slip | : | n = 0 |
| | Validation | : | n = 0 |

[Function] Selects printer station

| n | Selected Station |
|--------|---------------------------------|
| 0, "0" | Selects Thermal Receipt Station |
| 1, "1" | Reserved |
| 2, "2" | Reserved |
| 3, "3" | Selects Slip Station |
| 4, "4" | Selects Validation Station |

Switches to the printer station using this command after printing data in the line buffer. Therefore, always append an LF to the print data just before this command.

<Slip>, <Validation>

When station is switched, conditions such as data in the page, the page print region, and the printing direction are all initialized.

Command is ignored when page mode is selected.

3-16) Presenter Related Command Details

The following commands control the presenter functions.

The following commands are effective only on models equipped with a presenter.

ESC SYN 0 n

[Name] Execute presenter paper recovery

| | | | | | |
|--------|-------------|-----|-----|----|---|
| [Code] | ASCII | ESC | SYN | 0 | n |
| | Hexadecimal | 1B | 16 | 30 | n |
| | Decimal | 27 | 22 | 48 | n |

[Defined Area] Thermal : -

Slip : -

Validation : -

[Initial Value] Thermal : -

Slip : -

Validation : -

[Function]

Four bytes ignored

ESC SYN 1 n

[Name] Set presenter paper automatic recovery function and automatic recovery time

| | | | | | |
|--------|-------------|-----|-----|----|---|
| [Code] | ASCII | ESC | SYN | 1 | n |
| | Hexadecimal | 1B | 16 | 31 | n |
| | Decimal | 27 | 22 | 49 | n |

[Defined Area] Thermal : -

Slip : -

Validation : -

[Initial Value] Thermal : -

Slip : -

Validation : -

[Function]

Four bytes ignored

ESC SYN 3 n

[Name] Acquire presenter paper counter

| | | | | | |
|--------|-------------|-----|-----|----|---|
| [Code] | ASCII | ESC | SYN | 3 | n |
| | Hexadecimal | 1B | 16 | 33 | n |
| | Decimal | 27 | 22 | 51 | n |

[Defined Area] Thermal : -

Slip : -

Validation : -

[Initial Value] Thermal : -

Slip : -

Validation : -

[Function]

Four bytes ignored

ESC SYN 4 n

[Name] Initialize presenter paper counter

| | | | | | |
|--------|-------------|-----|-----|----|---|
| [Code] | ASCII | ESC | SYN | 4 | n |
| | Hexadecimal | 1B | 16 | 4 | n |
| | Decimal | 27 | 22 | 52 | n |

[Defined Area] Thermal : -
 Slip : -
 Validation : -

[Initial Value] Thermal : -
 Slip : -
 Validation : -

[Function] Four bytes ignored

3-17) MICR Related Command Details

The following commands control MICR functions.
 The following commands are effective only on models equipped with MICR.

ESC FS M m n

| | | | | | | |
|-----------------|---------------|-----|-----------------------------|----|---|---|
| [Name] | MICR function | | | | | |
| [Code] | ASCII | ESC | FS | M | m | n |
| | Hexadecimal | 1B | 1C | 4D | m | n |
| | Decimal | 27 | 28 | 77 | m | n |
| [Defined Area] | Thermal | : | - | | | |
| | Slip | : | 48 ≤ m ≤ 50 ("0" ≤ m ≤ "2") | | | |
| | | | n = 48, 49 | | | |
| | Validation | : | - | | | |
| [Initial Value] | Thermal | : | - | | | |
| | Slip | : | - | | | |
| | Validation | : | - | | | |

[Function]

<Thermal>, <Validation>

Five bytes ignored

<Slip>

Performs operations on inserted slip paper (cleaning paper).

Note that if slip paper has been inserted, and already is targeted for printing, that slip paper is discharged to the back (the forward direction), and operations are performed on the newly inserted slip paper (cleaning paper).

| m | Function |
|----|---|
| 48 | Reads format specified by n, and returns read character string. n=48 ••• E13B read format n=49 ••• CMC7 read format Reading successful ••• ESC FS M 0 n, read character string LF NUL Reading failed ••• ESC FS M 0 n, LF NUL |
| 49 | Reads with format specified by n, and returns read character string. If no slip paper has been inserted, an empty character is returned immediately that indicates no insertion. n=48 ••• E13B read format n=49 ••• CMC7 read format Reading successful ••• ESC FS M 1 n, read character string LF NUL Reading failed ••• ESC FS M 1 n, LF NUL Empty character string ••• ESC FS M 1 n LF NUL |
| 50 | Performs cleaning of the conveyance rollers and magnetic head by inserted cleaning paper. n is 48 or 49. |

In page mode, five bytes ignored.

E13B Support Table

| Type | Numbers | SYMBOL1 | SYMBOL2 | SYMBOL3 | SYMBOL4 |
|---------|----------|---------|---------|---------|---------|
| ASCII | 0 to 9 | T | A | O | D |
| Hex | 30 to 39 | 54 | 41 | 4F | 44 |
| Decimal | 48 to 57 | 84 | 65 | 79 | 68 |

CMC7 Support Table

| Type | Numbers | S I | S II | S III | S IV | S V |
|---------|----------|-----|------|-------|------|-----|
| ASCII | 0 to 9 | / | # | = | > | ^ |
| Hex | 30 to 39 | 2F | 23 | 3D | 3E | 5F |
| Decimal | 48 to 57 | 47 | 35 | 61 | 62 | 94 |

4. CHARACTER CODE TABLES

Character Code Specifications References

5. APPENDIX

5-1) Appendix 1: Bar Code Specification Details <Thermal>

Refer to the dedicated manuals for characteristics and methods of use for each bar code symbol. This section describes precautions and methods for setting when printing with the printer.

Bar code widths are set for each bar code according to the mode. The following describes each mode and the dot counts.

The user must ensure the specified printing position and quiet zone at the position where the bar code begins.

5-1-1) Code 39

Code 39 represents numbers 0 to 9 and the letters of the alphabet from A to Z. These are the symbols most frequently used today in industry.

1. Length of characters in each mode

| Items | Mode 1 | Mode 2 | Mode 3 | Mode 4 | Mode 5 | Mode 6 | Mode 7 | Mode 8 | Mode 9 |
|-----------------------|--------|--------|---------|---------|---------|---------|--------|---------|--------|
| Narrow Element Width | 2 Dots | 3 Dots | 4 Dots | 2 Dots | 3 Dots | 4 Dots | 2 Dots | 3 Dots | 4 Dots |
| Wide Element Width | 6 Dots | 9 Dots | 12 Dots | 5 Dots | 8 Dots | 10 Dots | 4 Dots | 6 Dots | 8 Dots |
| Ratio | 1:3 | 1:3 | 1:3 | 1:2.5 | 1:2.7 | 1:2.5 | 1:2 | 1:2 | 1:2 |
| Character Spacing | 2 Dots | 3 Dots | 4 Dots | 2 Dots | 3 Dots | 4 Dots | 2 Dots | 3 Dots | 4 Dots |
| Length of 1 Character | 4mm | 6mm | 8mm | 3.625mm | 5.625mm | 7.25mm | 3.25mm | 4.875mm | 6.5mm |

(*) The length of 1 character includes the character spacing.

2. Regulations

The start and stop bar code (*) in Code 39 are automatically inserted.

5-1-2) Interleaved 2 of 5

Interleaved 2 of 5 represents numbers 0 to 9.

Higher density of characters is possible and with JIS and EAN, and printing to cardboard for distribution has been standardized.

1) Narrow element width and length of symbols per 2 characters

| Items | Mode 1 | Mode 2 | Mode 3 | Mode 4 | Mode 5 | Mode 6 | Mode 7 | Mode 8 | Mode 9 |
|-----------------------|--------|---------|---------|--------|--------|---------|--------|--------|---------|
| Narrow Element Width | 2 Dots | 4 Dots | 6 Dots | 2 Dots | 4 Dots | 6 Dots | 2 Dots | 3 Dots | 4 Dots |
| Wide Element Width | 5 Dots | 10 Dots | 15 Dots | 4 Dots | 8 Dots | 12 Dots | 6 Dots | 9 Dots | 12 Dots |
| Ratio | 1:2.5 | 1:2.5 | 1:2.5 | 1:2 | 1:2 | 1:2 | 1:3 | 1:3 | 1:3 |
| Length of 1 Character | 4mm | 8mm | 12mm | 3.5mm | 7mm | 10.5mm | 4.5mm | 6.75mm | 9mm |

2. Regulations

- By selecting interleaved 2 of 5 bar code symbols, start and stop patterns are automatically inserted.
- When the bar code data digit count is odd, a zero is added to the highest value digit.
- Details conform to standards for AIM, USS-12/5, ANSI and JIS x 0502.

5-1-3) JAN/EAN/UPC

Used numbers, not only the bar code symbols, are controlled using JAN, EAN and UPC as shared common commercial codes.

Mainly, they are used for supermarkets such as shops and grocery stores.

1. Each mode and bar code width

| Items | | Mode 1 | Mode 2 | Mode 3 |
|--------------------|------------|---------|----------|--------|
| Module Width | | 2 Dots | 3 Dots | 4 Dots |
| Bar Code Width (*) | JAN/EAN-8 | 16.75mm | 25.125mm | 33.5mm |
| | JAN/EAN-13 | 23.75mm | 35.625mm | 47.5mm |
| | UPC-A | 23.75mm | 35.625mm | 47.5mm |
| | UPC-E | 12.75mm | 19.125mm | 25.5mm |

(*) Includes the guard bar (left/right/center) but not the white space.

2. Regulations

- JAN/EAN-8

Data is in 7 or 8 digits. The command is ignored for others.

The check digit uses a modulus weight of 10/3 and is automatically applied.

When the calculated value and the numerical value of the 8th digit differ, the calculated value has priority.

- JAN/EAN-13

Data is in 12 or 13 digits. The command is ignored for others.

The check digit uses a modulus weight of 10/3 and is automatically applied.

When the calculated value and the numerical value of the 13th digit differ, the calculated value has priority.

- UPC-A

Data is in 11 or 12 digits. The command is ignored for others.

The check digit uses a modulus weight of 10/3 and is automatically applied.

When the calculated value and the numerical value of the 12th digit differ, the calculated value has priority.

- UPC-A

Data is in 11 or 12 digits. The command is ignored for others.

The check digit uses a modulus weight of 10/3 and is automatically applied.

When the calculated value and the numerical value of the 12th digit differ, the calculated value has priority.

Data conversion to rectangles is automatic.

Data that cannot be shortened is processed as invalid data.

5-1-4) Code 128

These are bar code symbols that can print ASCII 128 characters.
For that reason, use thereof is increasing.

1. Each module and module width

| Items | Mode 1 | Mode 2 | Mode 3 |
|---------------------------|--------|---------|--------|
| Module Width | 2 Dots | 3 Dots | 4 Dots |
| Length of 1 Character (*) | 2.75mm | 4.125mm | 5.5mm |

(*) Start and stop bars not included.

2. Regulations

When using LF with the command, control codes are not sent by the host PC, so the control codes are sent as data, as shown below.

- When sending the following data, it is represented by a 2-character set.

% (25H) represented by %0 (25H 30H).

Control codes (00H to 1FH) represented by 40H to 5FH applied behind %.

Control code (7FH) represented by %5 (25H 35H).

Function codes represent 1 to 4 (31H to 34H) applied behind %.

Start codes represent 6 to 8 (36H to 38H) applied behind %.

- Stop code (SC)/Check character (CK) are automatically applied.

- When start code is omitted:

Uses START C when more than 4 digits continue after header.

Uses START A when initial data other than numbers are the control code.

Uses START B for other cases.

3. 2-Character set code table

<Control Codes>

<Control Codes>

| Code | Format |
|---------|------------|
| NUL 00H | %@ 25H 40H |
| SOH 01H | %A 25H 41H |
| STX 02H | %B 25H 42H |
| ETX 03H | %C 25H 43H |
| EOT 04H | %D 25H 44H |
| ENQ 05H | %E 25H 45H |
| ACK 06H | %F 25H 46H |
| BEL 07H | %G 25H 47H |
| BS 08H | %H 25H 48H |
| HT 09H | %I 25H 49H |
| LF 0AH | %J 25H 4AH |
| VT 0BH | %K 25H 4BH |
| FF 0CH | %L 25H 4CH |
| CR 0DH | %M 25H 4DH |
| SO 0EH | %N 25H 4EH |
| SI 0FH | %O 25H 4FH |
| DLE 10H | %P 25H 50H |
| DC1 11H | %Q 25H 51H |
| DC2 12H | %R 25H 52H |
| DC3 13H | %S 25H 53H |
| DC4 14H | %T 25H 54H |
| NAK 15H | %U 25H 55H |
| SYN 16H | %V 25H 56H |
| ETB 17H | %W 25H 57H |
| CAN 18H | %X 25H 58H |
| EM 19H | %Y 25H 59H |
| SUB 1AH | %Z 25H 5AH |
| ESC 1BH | %[25H 5BH |
| FS 1CH | %\ 25H 5CH |
| GS 1DH | %] 25H 5DH |
| RS 1EH | %^ 25H 5EH |
| US 1FH | %_ 25H 5FH |
| DEL 7FH | %5 25H 35H |

<Control Codes>

| Code | Format |
|-------|------------|
| % 25H | %0 25H 30H |

<Function Codes>

| Code | Format |
|------|------------|
| FNC1 | %1 25H 31H |
| FNC2 | %2 25H 32H |
| FNC3 | %3 25H 33H |
| FNC4 | %4 25H 34H |

*

*

*

*

<Start Codes>

| Code | Format |
|---------|------------|
| START A | %6 25H 36H |
| START B | %7 25H 37H |
| START C | %8 25H 38H |

*

*

*

5-1-5) Code 93

1. Each mode and module width

| Items | Mode 1 | Mode 2 | Mode 3 |
|---------------------------|--------|---------|--------|
| Module Width | 2 Dots | 3 Dots | 4 Dots |
| Length of 1 Character (*) | 2.25mm | 3.375mm | 4.5mm |

(*) Start and stop bars not included.

2. Regulations

- Start/stop codes are automatically applied.
- Check character (C, K) is automatically applied.
- 2 character set expression conforms to Code 128.

However, items marked with a star are codes that can only be used with Code 128, and not with Code 93.

5-1-6) NW7 (CODERBAR)

NW7 normally uses either A through D as the start/stop codes and represents special symbols (- (minus sign)/\$ (dollar sign): (colon)// (slash)/. (period)/+ (plus sign) between 0 to 9.

These are used as carrier package marking bar codes, DPE (photo prints) and for medical related industries (USA).

1. Length of characters in each mode

| Items | Mode 1 | Mode 2 | Mode 3 | Mode 4 | Mode 5 | Mode 6 | Mode 7 | Mode 8 | Mode 9 |
|-------------------------------------|--------|--------|--------|--------|--------|--------|--------|--------|--------|
| Narrow Element Width | 2 | 3 | 4 | 2 | 3 | 4 | 2 | 3 | 4 |
| Wide Element Width | 6 | 9 | 12 | 5 | 8 | 10 | 4 | 6 | 8 |
| Ratio | 1:3 | 1:3 | 1:3 | 1:2.5 | 1:2.7 | 1:2.5 | 1:2 | 1:2 | 1:2 |
| Character Spacing (Dots) | 2 | 3 | 4 | 2 | 3 | 4 | 2 | 3 | 4 |
| Length of 1 Character (Normally mm) | 3 | 4.5 | 6 | 2.75 | 4.25 | 5.5 | 2.5 | 3.75 | 5 |
| (Width mm) | 3.5 | 5.25 | 7 | 3.125 | 5.125 | 6.25 | 2.75 | 4.125 | 5.5 |

- With NW7, lengths differ because narrow elements and wide elements are included according to the characters.
- Normal characters (narrow: 5, wide: 2) and numbers (0 to 9), - and \$
- Wide characters (narrow: 4, wide: 3) :,/,.,+, A to D
- Character spaces are included in 1 character length.

5-2) Appendix 2 – Status Specifications <Shared>

This function is valid only when using an interface capable of bi-directional data communications. Refer to your printer's product specification manual to verify if the interface cable on the printer you use is capable of bi-directional data communications.

5-2-1) ENQ Command Status

This status is the one the printer transmits using the ENQ command.

| Bit | Contents | Status | | By model | | | | |
|-----|---------------------------|----------------|----------|----------|--|--|--|--|
| | | "0" | "1" | HSP7000 | | | | |
| 7 | Compulsion SW | Open | Closed | ○ | | | | |
| 6 | Reception Buffer Overflow | Does not occur | Occurs | ○ | | | | |
| 5 | Reception Buffer Empty | Has Data | Empty | ○ | | | | |
| 4 | Fixed at "0" | | - | - | | | | |
| 3 | Paper end | Paper | No paper | ○ | | | | |
| 2 | Other Errors | No | Yes | ○ | | | | |
| 1 | Framing Error | No | Yes | ○ | | | | |
| 0 | Parity Error | No | Yes | ○ | | | | |

- Reception over-flow errors/Framing errors/Parity errors
These errors are after holding the error and using this command to inquire the status and the error status is sent.
- Compulsion SW
When the conversion switch is ON, Bit 7 = 1.
- Other Errors
Indicates non-recoverable errors and cover open errors.

5-2-2) EOT Command Status

This status is the one the printer transmits using the EOT command.

| Bit | Contents | Status | | By model | | | | |
|-----|-----------------------------|--------|----------|----------|--|--|--|--|
| | | "0" | "1" | HSP7000 | | | | |
| 7 | | | | | | | | |
| 6 | Presenter Paper Jam Error | No | Yes | × | | | | |
| 5 | Paper Near-end (Outer Side) | Paper | No paper | × | | | | |
| 4 | Fixed at "1" | | - | - | | | | |
| 3 | Paper end | Paper | No paper | ○ | | | | |
| 2 | Paper Near-end (Inner Side) | Paper | No paper | ○ | | | | |
| 1 | BM Error | No | Yes | ○ | | | | |
| 0 | Fixed at "0" | | - | - | | | | |

- BM Error
On models that use a common PE and BM sensor, if a continuous error is detected beyond a determined amount, it indicates not a black mark error, but a paper out error.

5-2-3) Automatic Status

Automatic status is a group of states that are automatically returned from the printer to the host when the printer's status has changed. Automatic status is composed of "Header - 1," "Header - 2" and "plurality of bytes of the printer status and is continuously returned to the host. The host always uses an identifying method to identify the data for every byte received.

(It is possible that Xon/Xoff codes are exceptionally mixed in the auto status in the Xon/Xoff mode (when using a serial I/F), so it is necessary to consider that on the receiving side.)

The valid/invalid conditions of the automatic status abide by the DIPSW settings for the initial values.

It is possible to change the conditions using the ESC RS a n command after turning ON the power.

Also, it is possible to get the automatic status using the ESC ACK SOH command, regardless of the valid/invalid conditions.

(1) Header -1

Header - 1 is the 1 byte length information transmitted at the head of the automatic status.

The table below shows the composition of the Header -1. Header - 1 represents the entire status transmission byte count, including Header - 1, using bit 1 to bit 3 and bit 5. The host gets the transmission byte information and always receives the status data for that amount transmission bytes. For reference, the table below shows the relationship of actual transmission bytes and the Header - 1. Because the bit 0 that indicates that this is the Header - 1 is normally 1 (the second byte and beyond is 0), to detect the Header - 1, it is acceptable to verify that bit 0 is 1 and bit 4 = 0 for this data. Note that bit 6 is for future expansion and is ignored in host-side processes.

<Header -1 (First Byte)>

| Bit | Contents | Status | | By model | | | |
|-----|---------------------------|--------|-----|----------|--|--|--|
| | | "0" | "1" | HSP7000 | | | |
| 7 | Fixed at "0" | | - | - | | | |
| 6 | Reserved (Fixed at 0) | | - | - | | | |
| 5 | Printer Status Byte Count | | | ○ | | | |
| 4 | Fixed at "0" | | - | - | | | |
| 3 | Printer Status Byte Count | | | ○ | | | |
| 2 | Printer Status Byte Count | | | ○ | | | |
| 1 | Printer Status Byte Count | | | ○ | | | |
| 0 | Fixed at "1" | - | | - | | | |

Actual transmission byte count and header - 1 table

| Transmission Byte Count n ($7 \leq n \leq 15$) | Header -1 |
|--|--------------------|
| 7 | 00001111B (0F Hex) |
| 8 | 00100001B (21 Hex) |
| 9 | 00100011B (23 Hex) |
| 10 | 00100101B (25 Hex) |
| 11 | 00100111B (27 Hex) |
| 12 | 00101001B (29 Hex) |
| 13 | 00101011B (2B Hex) |
| 14 | 00101101B (2D Hex) |
| 15 | 00101111B (2F Hex) |

(2) Header -2

Header -2 is the 1 byte length information transmitted from the second byte of the automatic status. The table below shows the composition of the Header -2.

Header -2 represents the automatic status version (called automatic status version below) using bit 1 to bit 3 and bit 5. For reference, the table below shows the relationship of actual version bytes and the Header -2. The automatic status version will be used as new information is added to the printer status bit positions that were empty, by adding new functions in the future.

When the host does not control the automatic status version, it is acceptable to ignore Header - 2 received.

<Header -2 (Second Byte)>

| Bit | Contents | Status | | By model | | | | |
|-----|----------------------|--------------|-----------|----------|--|--|--|--|
| | | "0" | "1" | HSP7000 | | | | |
| 7 | ASB Status Expansion | No Expansion | Expansion | - | | | | |
| 6 | Version No. | | - | o | | | | |
| 5 | Version No. | | | o | | | | |
| 4 | Fixed at "0" | | - | - | | | | |
| 3 | Version No. | | | o | | | | |
| 2 | Version No. | | | o | | | | |
| 1 | Version No. | | | o | | | | |
| 0 | Fixed at "0" | - | | - | | | | |

Actual automatic status version and header -2 table

| Version No. n | Header -2 |
|---------------|--------------------|
| 1 | 0000010B (02 Hex) |
| 2 | 00000100B (04 Hex) |
| 3 | 00000110B (06 Hex) |
| 4 | 00001000B (08 Hex) |
| 5 | 00001010B (0A Hex) |
| 6 | 00001100B (0C Hex) |
| 7 | 00001110B (0E Hex) |
| 8 | 00100000B (20 Hex) |
| 9 | 00100010B (22 Hex) |
| • | • |
| • | • |
| • | • |
| 30 | 01101100B (6C Hex) |
| 31 | 01101110B (6E Hex) |

Printer Status Version

| Model Name | Version No. | Status |
|------------|-------------|--|
| HSP7000 | 3(06 Hex) | Up to printer status 7 (9 th byte) loaded |

(3) Printer Status

Printer status is the status of the printer sent from the 3rd byte of the automatic status.
 For the printer status, (the number of bytes added in Header -1 minus two) is returned.
 Printer status is always updated for new information. (No log exists.)
 The following shows the composition of the status.

<Printer status 1 Printer status (Third Byte)>

| Bit | Contents | Status | | By model | | | |
|-----|-------------------------|--------------|----------|----------|--|--|--|
| | | "0" | "1" | HSP7000 | | | |
| 7 | Fixed at "0" | | - | - | | | |
| 6 | OFFLINE By Switch Input | No | Occurs | × | | | |
| 5 | Cover Status | Closed | Open | ○ | | | |
| 4 | Fixed at "0" | | - | - | | | |
| 3 | ONLINE/OFFLINE Status | ONLINE | OFFLINE | ○ | | | |
| 2 | Compulsion SW | Open | Closed | ○ | | | |
| 1 | ETB Command | Not Executed | Executed | ○ | | | |
| 0 | Fixed at "0" | | - | - | | | |

- ETB Command

Cleared when received at the host (by clearing bit 1 to 0, automatic status is not targeted to occur).

<Printer status 2 Error Information (Fourth Byte)>

| Bit | Contents | Status | | By model | | | |
|-----|----------------------------------|-------------|---------|----------|--|--|--|
| | | "0" | "1" | HSP7000 | | | |
| 7 | Fixed at "0" | | - | - | | | |
| 6 | Stopped by high head temperature | Not stopped | Stopped | ○ | | | |
| 5 | Non-recoverable Error | No | Yes | ○ | | | |
| 4 | Fixed at "0" | | - | - | | | |
| 3 | Auto-cutter Error | No | Yes | ○ | | | |
| 2 | Mechanical Error | No | Yes | ○ | | | |
| 1 | Not Used (Fixed at "0") | | | - | | | |
| 0 | Fixed at "0" | | - | - | | | |

<Printer status 3 Error Information (Fifth Byte)>

| Bit | Contents | Status | | By model | | | |
|-----|------------------------------|----------------|--------|----------|--|--|--|
| | | "0" | "1" | HSP7000 | | | |
| 7 | Fixed at "0" | | - | - | | | |
| 6 | Reception Buffer Overflow | Does not occur | Occurs | ○ | | | |
| 5 | Command Error (in Page Mode) | No | Yes | × | | | |
| 4 | Fixed at "0" | | - | - | | | |
| 3 | BM Error | No | Yes | ○ | | | |
| 2 | Presenter Paper Jam Error | No | Yes | × | | | |
| 1 | Head Up Error | No | Yes | × | | | |
| 0 | Fixed at "0" | | - | - | | | |

- Reception Buffer Overflow

Cleared to 0 when returned to the host.

- Command Error (in Page Mode)

Command errors cleared to 0 when returned to the host.

- BM Error

On models that use a common PE and BM sensor, if a continuous error is detected beyond a determined amount, it indicates not a black mark error, but a paper out error.

<Printer status 4 Sensor Information (Sixth Byte)>

| Bit | Contents | Status | | By model | | | |
|-----|-----------------------------|--------|----------|----------|--|--|--|
| | | "0" | "1" | HSP7000 | | | |
| 7 | Fixed at "0" | | - | - | | | |
| 6 | Not Used (Fixed at "0") | | - | - | | | |
| 5 | Not Used (Fixed at "0") | | - | - | | | |
| 4 | Fixed at "0" | | - | - | | | |
| 3 | Paper end | Paper | No paper | ○ | | | |
| 2 | Paper Near-end (Inner Side) | Paper | No paper | ○ | | | |
| 1 | Paper Near-end (Outer Side) | Paper | No paper | × | | | |
| 0 | Fixed at "0" | | - | - | | | |

<Printer status 5 Sensor Information (Seventh Byte)>

| Bit | Contents | Status | | By model | | | |
|-----|-------------------------------|----------|----------|----------|--|--|--|
| | | "0" | "1" | HSP7000 | | | |
| 7 | Fixed at "0" | | - | - | | | |
| 6 | Slip/Validation | | | ○ | | | |
| | Condition | | | | | | |
| 5 | Slip/Validation | | | ○ | | | |
| | Condition | | | | | | |
| 4 | Fixed at "0" | | - | - | | | |
| 3 | Slip BOF Detector | Paper | No paper | ○ | | | |
| 2 | Slip TOF Detector | Paper | No paper | × | | | |
| | Slip COF Detector | Paper | No paper | ○ | | | |
| 1 | Presenter Paper Detector | No paper | Paper | × | | | |
| | Stack Sensor Paper Detector | No paper | Paper | × | | | |
| | Peeling Sensor Paper Detector | No paper | Paper | × | | | |
| | Slip TOF Detector | Paper | No paper | ○ | | | |
| 0 | Fixed at "0" | | - | - | | | |

Slip/Validation Condition Support Table

| Bit 6 | Bit 5 | Condition |
|-------|-------|---------------------------------|
| 0 | 0 | Slip Paper (MICR Target) |
| 0 | 1 | Slip Paper (Print Target) |
| 1 | 0 | Validation Paper (Print Target) |
| 1 | 1 | No paper |

<Printer status 6 ETB Counter (Eighth Byte)>

| Bit | Contents | Status | | By model | | | |
|-----|-------------------|--------|-----|----------|--|--|--|
| | | "0" | "1" | HSP7000 | | | |
| 7 | Fixed at "0" | | - | - | | | |
| 6 | ETB Counter Bit-4 | | | o | | | |
| 5 | ETB Counter Bit-3 | | | o | | | |
| 4 | Fixed at "0" | | - | - | | | |
| 3 | ETB Counter Bit-2 | | | o | | | |
| 2 | ETB Counter Bit-1 | | | o | | | |
| 1 | ETB Counter Bit-0 | | | o | | | |
| 0 | Fixed at "0" | | - | - | | | |

(*) ETB Counter

This counter is the 5 bit ETB counter.

(It counts from 0 to 31. When the counter overflows, it counts up from 31 to 0.)

This counter is incremented by 1 using the <ETB> command.

The ETB counter is initialized by the following commands. When doing so, ASB ETB status is cleared. However, when initializing the ETB counter, ASB is not transmitted.

<ETB Counter Initialization Commands>

- <ESC><RS> E n : ETB Counter Initialization
- <CAN> : Cancel print data and initialize commands

<Printer status 7 Position for Presenter Paper (Ninth Byte)>

| Bit | Contents | Status | | By model | | | |
|-----|--------------------------|--------|-----|----------|--|--|--|
| | | "0" | "1" | HSP7000 | | | |
| 7 | Fixed at "0" | | - | - | | | |
| 6 | Not Used (Fixed at "0") | | - | x | | | |
| 5 | Not Used (Fixed at "0") | | - | x | | | |
| 4 | Fixed at "0" | | - | - | | | |
| 3 | Presenter Paper Position | | | x | | | |
| 2 | Presenter Paper Position | | | x | | | |
| 1 | Presenter Paper Position | | | x | | | |
| 0 | Fixed at "0" | | - | - | | | |

(4) <Note>

Do not use ENQ, EOT, ESC, ACK and SOH when automatic status is valid. Invalidate the automatic status in advance using the DIPSW (memory switch) or the ESC RS a n command to query these.

(5) Status identification method

| Command/Functions | Status | | | | | | | |
|----------------------------|--------|-------|-------|-------|-------|-------|-------|-------|
| | bit 7 | bit 6 | bit 5 | bit 4 | bit 3 | bit 2 | bit 1 | bit 0 |
| XON | 0 | 0 | 0 | 1 | 0 | 0 | 0 | 1 |
| XOFF | 0 | 0 | 0 | 1 | 0 | 0 | 1 | 1 |
| ENQ | * | * | * | 0 | * | * | * | * |
| EOT | * | * | * | 1 | * | * | * | 0 |
| ASB (Header -1) | 0 | * | * | 0 | * | * | * | 1 |
| ASB (Other than Header -1) | 0 | * | * | 0 | * | * | * | 0 |

0 = fixed at "0" bits/1 = fixed at "1" bits/* = variable bits.

5-2-4) Printer Status Transmission Specification when using Ethernet and Wireless LAN Interfaces

The following explains the printer status transmission specification when using Ethernet and wireless LAN interfaces.

1) Transmission format:

• When transmitting only STAR ASB:

STAR ASB (Second Byte Bit-7=1) + Length (Length = 0x0000)

• When transmitting printer status other than STAR ASB:

STAR ASB (Second Byte Bit-7=1) + Length + Status Data

<Length Details>

- 2 byte value indicating status data byte count ($0x0000 \leq \text{Length} \leq 0x0200$)
- When the status data is 10 bytes: Length = 0x000a
- When transmitting only STAR ASB: Add Length = 0x0000
- When Star ASB Second byte Bit-7, and Length is added, Bit-7 = 1 is set.

For status analysis, the total byte count of ASB is detected using the first byte of Star ASB, and whether length is added with the second byte Bit-7 of Star ASB is detected. By getting the byte count of subsequent status data using the length, the status can be analyzed.

2) Status Data Transmission Format:

Status Type + Delimiter 1 + Data Type + Status Length + **Printer Status** + Delimiter 2

(1) Status Type (2byte or 4byte)

• First and second bytes

Indicate a factor of printer status occurring.

- "00": Reserved
- "01" to "09": Star real-time status request command
- "10" to "49": **STAR Status Request Command**
- "50" to "59": Reserved
- "60" to "99": Reserved
- "A0": MICR Function Command
- "A1" to "FF": Reserved

• Third and fourth bytes

If the factor is the command, indicates the n parameter of the command.

If there is no n parameter, the third and fourth bytes can be omitted.

<Ex.> If n = 0x31 with the ESC SYN 3 n command, the third and fourth bytes are "31."

(2) Delimiter 1 (1 Byte)

Sends ":".

(3) Data Type (1byte)

Indicates the data type of the printer status, and sends "B" (binary type).

(4) Status Length (2byte)

2 byte value indicating byte count of printer status

(5) Printer status (variable)

Status sent by printer

The content of the status differs according to the cause.

Refer to Commands That are Factors, and Automatic Status for details on the content of the status.

(6) Delimiter 2 (1 byte)

Sends “,”.

3) Status transmission specifications list

| Status Generating Factors | STAR ASB | Length | Status Data | | | | | | |
|---|----------|-----------------|--------------------------------|--|-------------|-----------|-----------------|----------------|-------------|
| | | | Status Type | | Delimiter 1 | Data Type | Status Length | Printer Status | Delimiter 2 |
| | | | First and Second Bytes Factors | Third and Fourth Bytes n Parameter | | | | | |
| ASB Auto Status | ASB | 0x0000 | -- | -- | -- | -- | -- | -- | -- |
| ESC ACK SOH Printer Status Request | ASB | 0x0000 | -- | -- | -- | -- | -- | -- | -- |
| ENQ Printer Status Request | ASB | 0x0008 | “01” | Omitted | “.” “.” | “B” | 0x0001 | Status | “,” “,” |
| EOT Printer Status Request | ASB | 0x0008 | “02” | Omitted | “.” “.” | “B” | 0x0001 | Status | “,” “,” |
| ESC SYN 3 n Presenter Counter Request | ASB | 0x0011 | “13” | “00” ≤ n ≤ “01” “30” ≤ n ≤ “31” | “.” “.” | “B” | 0x0008 | Status | “,” “,” |
| ESC GS x I PDF417 Information Request | ASB | 0x000C | “16” | Omitted | “.” “.” | “B” | 0x0005 | Status | “,” “,” |
| ESC GS y I QR Code Information Request | ASB | 0x000D | “19” | Omitted | “.” “.” | “B” | 0x0006 | Status | “,” “,” |
| ESC FS M m n MICR Function | ASB | Variable Length | “A0” | “30” ≤ n ≤ “31” | “.” “.” | “B” | Variable Length | Status | “,” “,” |

5-3) Appendix 3 – Blank Code Page Configuration <Thermal>

Blank code pages are character code tables that are empty from character code 80H to FFH. They can be specified using the command below.

- ESC GS t n (n = 255)

Also, it is possible to write data to the blank code page area using the command below.

- ESC GS =

When registering data, Font A and Font B data must be registered as a set.

1. Example configuration of Font A data. (12 x 24 font)

| | MSB | | | | LSB | | | | | MSB | | | | LSB | | | |
|-----|-----|---|---|---|-----|---|---|---|-----|-----|---|---|--|-----|---|---|---|
| d1 | | | | | | | | | d2 | | | | | 0 | 0 | 0 | 0 |
| d3 | | | | | ● | ● | ● | ● | d4 | | | | | 0 | 0 | 0 | 0 |
| d5 | | | ● | ● | ● | ● | ● | ● | d6 | ● | ● | | | 0 | 0 | 0 | 0 |
| d7 | | | ● | ● | | | | | d8 | ● | ● | | | 0 | 0 | 0 | 0 |
| d9 | ● | ● | | | | | | | d10 | | ● | ● | | 0 | 0 | 0 | 0 |
| d11 | ● | ● | | | | | | | d12 | | ● | ● | | 0 | 0 | 0 | 0 |
| d13 | ● | ● | | | | | | | d14 | | ● | ● | | 0 | 0 | 0 | 0 |
| d15 | | | | | | | | | d16 | | ● | ● | | 0 | 0 | 0 | 0 |
| d17 | | | | | | | | | d18 | ● | ● | | | 0 | 0 | 0 | 0 |
| d19 | | | | | | | | | d20 | ● | ● | | | 0 | 0 | 0 | 0 |
| d21 | | | | | | | | ● | d22 | ● | | | | 0 | 0 | 0 | 0 |
| d23 | | | | | | | | ● | d24 | | | | | 0 | 0 | 0 | 0 |
| d25 | | | | | | | | ● | d26 | | | | | 0 | 0 | 0 | 0 |
| d27 | | | | | | | | ● | d28 | | | | | 0 | 0 | 0 | 0 |
| d29 | | | | | | | | ● | d30 | | | | | 0 | 0 | 0 | 0 |
| d31 | | | | | | | | ● | d32 | | | | | 0 | 0 | 0 | 0 |
| d33 | | | | | | | | ● | d34 | | | | | 0 | 0 | 0 | 0 |
| d35 | | | | | | | | ● | d36 | | | | | 0 | 0 | 0 | 0 |
| d37 | | | | | | | | ● | d38 | | | | | 0 | 0 | 0 | 0 |
| d39 | | | | | | | | ● | d40 | ● | ● | ● | | 0 | 0 | 0 | 0 |
| d41 | | | | | | | | ● | d42 | ● | ● | ● | | 0 | 0 | 0 | 0 |
| d43 | | | | | | | | | d44 | | | | | 0 | 0 | 0 | 0 |
| d45 | | | | | | | | | d46 | | | | | 0 | 0 | 0 | 0 |
| d47 | | | | | | | | | d48 | | | | | 0 | 0 | 0 | 0 |

Fig. A-1 12 x 24 Font

2. Example configuration of Font B data. (9 x 24 font)

Fig. A-2 9 x 24 Font

| | MSB | | | | LSB | | | | | MSB | | | | LSB | | | |
|-----|-----|--|--|--|-----|---|---|---|-----|-----|---|---|---|-----|---|---|---|
| d1 | | | | | | | | | d2 | 0 | 0 | 0 | 0 | 0 | 0 | 0 | 0 |
| d3 | | | | | • | • | • | | d4 | 0 | 0 | 0 | 0 | 0 | 0 | 0 | 0 |
| d5 | | | | | • | • | • | • | d6 | 0 | 0 | 0 | 0 | 0 | 0 | 0 | 0 |
| d7 | | | | | • | • | | • | d8 | 0 | 0 | 0 | 0 | 0 | 0 | 0 | 0 |
| d9 | | | | | • | • | | • | d10 | 0 | 0 | 0 | 0 | 0 | 0 | 0 | 0 |
| d11 | | | | | • | • | | • | d12 | 0 | 0 | 0 | 0 | 0 | 0 | 0 | 0 |
| d13 | | | | | • | • | | • | d14 | 0 | 0 | 0 | 0 | 0 | 0 | 0 | 0 |
| d15 | | | | | | | | • | d16 | 0 | 0 | 0 | 0 | 0 | 0 | 0 | 0 |
| d17 | | | | | | | | • | d18 | 0 | 0 | 0 | 0 | 0 | 0 | 0 | 0 |
| d19 | | | | | | | | • | d20 | 0 | 0 | 0 | 0 | 0 | 0 | 0 | 0 |
| d21 | | | | | | | | • | d22 | 0 | 0 | 0 | 0 | 0 | 0 | 0 | 0 |
| d23 | | | | | | | | • | d24 | 0 | 0 | 0 | 0 | 0 | 0 | 0 | 0 |
| d25 | | | | | | | | • | d26 | 0 | 0 | 0 | 0 | 0 | 0 | 0 | 0 |
| d27 | | | | | | | | • | d28 | 0 | 0 | 0 | 0 | 0 | 0 | 0 | 0 |
| d29 | | | | | | | | • | d30 | 0 | 0 | 0 | 0 | 0 | 0 | 0 | 0 |
| d31 | | | | | | | | • | d32 | 0 | 0 | 0 | 0 | 0 | 0 | 0 | 0 |
| d33 | | | | | | | | • | d34 | 0 | 0 | 0 | 0 | 0 | 0 | 0 | 0 |
| d35 | | | | | | | | • | d36 | 0 | 0 | 0 | 0 | 0 | 0 | 0 | 0 |
| d37 | | | | | | | | • | d38 | 0 | 0 | 0 | 0 | 0 | 0 | 0 | 0 |
| d39 | | | | | | | | • | d40 | 0 | 0 | 0 | 0 | 0 | 0 | 0 | 0 |
| d41 | | | | | | | | • | d42 | 0 | 0 | 0 | 0 | 0 | 0 | 0 | 0 |
| d43 | | | | | | | | | d44 | 0 | 0 | 0 | 0 | 0 | 0 | 0 | 0 |
| d45 | | | | | | | | | d46 | 0 | 0 | 0 | 0 | 0 | 0 | 0 | 0 |
| d47 | | | | | | | | | d48 | 0 | 0 | 0 | 0 | 0 | 0 | 0 | 0 |

5-4) Appendix 4: QR Code Maximum Input Character Count in Each Version <Thermal>

1) Model 1 Versions and Maximum Input Character Count

| Version | Number of Cells on One Side | Error Correction Level | Numbers | English Language Characters | Binary | Kanji Character |
|---------|-----------------------------|------------------------|---------|-----------------------------|--------|-----------------|
| 1 | 21 | L | 40 | 24 | 17 | 10 |
| | | M | 33 | 20 | 14 | 8 |
| | | Q | 25 | 15 | 11 | 6 |
| | | H | 16 | 10 | 7 | 4 |
| 2 | 25 | L | 81 | 49 | 34 | 20 |
| | | M | 66 | 40 | 28 | 17 |
| | | Q | 52 | 31 | 22 | 13 |
| | | H | 33 | 20 | 14 | 8 |
| 3 | 29 | L | 131 | 79 | 55 | 33 |
| | | M | 100 | 60 | 42 | 25 |
| | | Q | 81 | 49 | 34 | 20 |
| | | H | 52 | 31 | 22 | 13 |
| 4 | 33 | L | 186 | 113 | 78 | 48 |
| | | M | 138 | 84 | 58 | 35 |
| | | Q | 114 | 69 | 48 | 29 |
| | | H | 76 | 46 | 32 | 19 |
| 5 | 37 | L | 253 | 154 | 106 | 65 |
| | | M | 191 | 116 | 80 | 49 |
| | | Q | 157 | 95 | 66 | 40 |
| | | H | 105 | 63 | 44 | 27 |
| 6 | 41 | L | 321 | 194 | 134 | 82 |
| | | M | 249 | 151 | 104 | 64 |
| | | Q | 201 | 122 | 84 | 51 |
| | | H | 133 | 81 | 56 | 34 |
| 7 | 45 | L | 402 | 244 | 168 | 103 |
| | | M | 311 | 188 | 130 | 80 |
| | | Q | 253 | 154 | 106 | 65 |
| | | H | 167 | 101 | 70 | 43 |
| 8 | 49 | L | 493 | 299 | 206 | 126 |
| | | M | 378 | 229 | 158 | 97 |
| | | Q | 301 | 183 | 126 | 77 |
| | | H | 203 | 123 | 85 | 52 |
| 9 | 53 | L | 585 | 354 | 244 | 150 |
| | | M | 441 | 267 | 184 | 113 |
| | | Q | 369 | 223 | 154 | 94 |
| | | H | 239 | 145 | 100 | 61 |
| 10 | 57 | L | 690 | 418 | 287 | 177 |
| | | M | 526 | 319 | 219 | 135 |
| | | Q | 433 | 262 | 180 | 111 |
| | | H | 291 | 176 | 121 | 74 |
| 11 | 61 | L | 800 | 485 | 333 | 205 |
| | | M | 608 | 368 | 253 | 156 |
| | | Q | 493 | 299 | 205 | 126 |
| | | H | 342 | 207 | 142 | 87 |
| 12 | 65 | L | 915 | 555 | 381 | 234 |
| | | M | 694 | 421 | 289 | 178 |
| | | Q | 579 | 351 | 241 | 148 |
| | | H | 390 | 236 | 162 | 100 |
| 13 | 69 | L | 1030 | 624 | 429 | 264 |
| | | M | 790 | 479 | 329 | 202 |
| | | Q | 656 | 398 | 273 | 168 |
| | | H | 454 | 275 | 189 | 116 |
| 14 | 73 | L | 1167 | 707 | 486 | 299 |
| | | M | 877 | 531 | 365 | 225 |
| | | Q | 738 | 447 | 307 | 189 |
| | | H | 498 | 302 | 207 | 127 |

2) Model 2 Versions and Maximum Input Character Count

| Version | Number of Cells on One Side | Error Correction Level | Numbers | English Language Characters | Binary | Kanji Character |
|---------|-----------------------------|------------------------|---------|-----------------------------|--------|-----------------|
| 1 | 21 | L | 41 | 25 | 17 | 10 |
| | | M | 34 | 20 | 14 | 8 |
| | | Q | 27 | 16 | 11 | 7 |
| | | H | 17 | 10 | 7 | 4 |
| 2 | 25 | L | 77 | 47 | 32 | 20 |
| | | M | 63 | 38 | 26 | 16 |
| | | Q | 48 | 29 | 20 | 12 |
| | | H | 34 | 20 | 14 | 8 |
| 3 | 29 | L | 127 | 77 | 53 | 32 |
| | | M | 101 | 61 | 42 | 26 |
| | | Q | 77 | 47 | 32 | 20 |
| | | H | 58 | 35 | 24 | 15 |
| 4 | 33 | L | 187 | 114 | 78 | 48 |
| | | M | 149 | 90 | 62 | 38 |
| | | Q | 111 | 67 | 46 | 28 |
| | | H | 82 | 50 | 34 | 21 |
| 5 | 37 | L | 255 | 154 | 106 | 65 |
| | | M | 202 | 122 | 84 | 52 |
| | | Q | 144 | 87 | 60 | 37 |
| | | H | 106 | 64 | 44 | 27 |
| 6 | 41 | L | 322 | 195 | 134 | 82 |
| | | M | 255 | 154 | 106 | 65 |
| | | Q | 178 | 108 | 74 | 45 |
| | | H | 139 | 84 | 58 | 36 |
| 7 | 45 | L | 370 | 224 | 154 | 95 |
| | | M | 293 | 178 | 122 | 75 |
| | | Q | 207 | 125 | 86 | 53 |
| | | H | 154 | 93 | 64 | 39 |
| 8 | 49 | L | 461 | 279 | 192 | 118 |
| | | M | 365 | 221 | 152 | 93 |
| | | Q | 259 | 157 | 108 | 66 |
| | | H | 202 | 122 | 84 | 52 |
| 9 | 53 | L | 552 | 335 | 230 | 141 |
| | | M | 432 | 262 | 180 | 111 |
| | | Q | 312 | 189 | 130 | 80 |
| | | H | 235 | 143 | 98 | 60 |
| 10 | 57 | L | 652 | 395 | 271 | 167 |
| | | M | 513 | 311 | 213 | 131 |
| | | Q | 364 | 221 | 151 | 93 |
| | | H | 288 | 174 | 119 | 74 |
| 11 | 61 | L | 772 | 468 | 321 | 198 |
| | | M | 604 | 366 | 251 | 155 |
| | | Q | 427 | 259 | 177 | 109 |
| | | H | 331 | 200 | 137 | 85 |
| 12 | 65 | L | 883 | 535 | 367 | 226 |
| | | M | 691 | 419 | 287 | 177 |
| | | Q | 489 | 296 | 203 | 125 |
| | | H | 374 | 227 | 155 | 96 |
| 13 | 69 | L | 1022 | 619 | 425 | 262 |
| | | M | 796 | 483 | 331 | 204 |
| | | Q | 580 | 352 | 241 | 149 |
| | | H | 427 | 259 | 177 | 109 |
| 14 | 73 | L | 1101 | 667 | 458 | 282 |
| | | M | 871 | 528 | 362 | 223 |
| | | Q | 621 | 376 | 258 | 159 |
| | | H | 468 | 283 | 194 | 120 |
| 15 | 77 | L | 1250 | 758 | 520 | 320 |
| | | M | 991 | 600 | 412 | 254 |
| | | Q | 703 | 426 | 292 | 180 |
| | | H | 530 | 321 | 220 | 136 |

| Version | Number of Cells on One Side | Error Correction Level | Numbers | English Language Characters | Binary | Kanji Character |
|---------|-----------------------------|------------------------|---------|-----------------------------|--------|-----------------|
| 16 | 81 | L | 1408 | 854 | 586 | 361 |
| | | M | 1082 | 656 | 450 | 277 |
| | | Q | 775 | 470 | 322 | 198 |
| | | H | 602 | 365 | 250 | 154 |
| 17 | 85 | L | 1548 | 938 | 644 | 397 |
| | | M | 1212 | 734 | 504 | 310 |
| | | Q | 876 | 531 | 364 | 224 |
| | | H | 674 | 408 | 280 | 173 |
| 18 | 89 | L | 1725 | 1046 | 718 | 442 |
| | | M | 1346 | 816 | 560 | 345 |
| | | Q | 948 | 574 | 394 | 243 |
| | | H | 746 | 452 | 310 | 191 |
| 19 | 93 | L | 1903 | 1153 | 792 | 488 |
| | | M | 1500 | 909 | 624 | 384 |
| | | Q | 1063 | 644 | 442 | 272 |
| | | H | 813 | 493 | 338 | 208 |
| 20 | 97 | L | 2061 | 1249 | 858 | 528 |
| | | M | 1600 | 970 | 666 | 410 |
| | | Q | 1159 | 702 | 482 | 297 |
| | | H | 919 | 557 | 382 | 235 |
| 21 | 101 | L | 2232 | 1352 | 929 | 572 |
| | | M | 1708 | 1035 | 711 | 438 |
| | | Q | 1224 | 742 | 509 | 314 |
| | | H | 969 | 587 | 403 | 248 |
| 22 | 105 | L | 2409 | 1460 | 1003 | 618 |
| | | M | 1872 | 1134 | 779 | 480 |
| | | Q | 1358 | 823 | 565 | 348 |
| | | H | 1056 | 640 | 439 | 270 |
| 23 | 109 | L | 2620 | 1588 | 1091 | 672 |
| | | M | 2059 | 1248 | 857 | 528 |
| | | Q | 1468 | 890 | 611 | 376 |
| | | H | 1108 | 672 | 461 | 284 |
| 24 | 113 | L | 2812 | 1704 | 1171 | 721 |
| | | M | 2188 | 1326 | 911 | 561 |
| | | Q | 1588 | 963 | 661 | 407 |
| | | H | 1228 | 744 | 511 | 315 |
| 25 | 117 | L | 3057 | 1853 | 1273 | 784 |
| | | M | 2395 | 1451 | 997 | 614 |
| | | Q | 1718 | 1041 | 715 | 440 |
| | | H | 1286 | 779 | 535 | 330 |
| 26 | 121 | L | 3283 | 1990 | 1367 | 842 |
| | | M | 2544 | 1542 | 1059 | 652 |
| | | Q | 1804 | 1094 | 751 | 462 |
| | | H | 1425 | 864 | 593 | 365 |
| 27 | 125 | L | 3514 | 2132 | 1465 | 902 |
| | | M | 2701 | 1637 | 1125 | 692 |
| | | Q | 1933 | 1172 | 805 | 496 |
| | | H | 1501 | 910 | 625 | 385 |
| 28 | 129 | L | 3669 | 2223 | 1528 | 940 |
| | | M | 2857 | 1732 | 1190 | 732 |
| | | Q | 2085 | 1263 | 868 | 534 |
| | | H | 1581 | 958 | 658 | 405 |
| 29 | 133 | L | 3909 | 2369 | 1628 | 1002 |
| | | M | 3035 | 1839 | 1264 | 778 |
| | | Q | 2181 | 1322 | 908 | 559 |
| | | H | 1677 | 1016 | 698 | 430 |
| 30 | 137 | L | 4158 | 2520 | 1732 | 1066 |
| | | M | 3289 | 1994 | 1370 | 843 |
| | | Q | 2358 | 1429 | 982 | 604 |
| | | H | 1782 | 1080 | 742 | 457 |

| Version | Number of Cells on One Side | Error Correction Level | Numbers | English Language Characters | Binary | Kanji Character |
|---------|-----------------------------|------------------------|---------|-----------------------------|--------|-----------------|
| 31 | 141 | L | 4417 | 2677 | 1840 | 1132 |
| | | M | 3486 | 2113 | 1452 | 894 |
| | | Q | 2473 | 1499 | 1030 | 634 |
| | | H | 1897 | 1150 | 790 | 486 |
| 32 | 145 | L | 4686 | 2840 | 1952 | 1201 |
| | | M | 3693 | 2238 | 1538 | 947 |
| | | Q | 2670 | 1618 | 1112 | 684 |
| | | H | 2022 | 1226 | 842 | 518 |
| 33 | 149 | L | 4965 | 3009 | 2068 | 1273 |
| | | M | 3909 | 2369 | 1628 | 1002 |
| | | Q | 2805 | 1700 | 1168 | 719 |
| | | H | 2157 | 1307 | 898 | 553 |
| 34 | 153 | L | 5253 | 3183 | 2188 | 1347 |
| | | M | 4134 | 2506 | 1722 | 1060 |
| | | Q | 2949 | 1787 | 1228 | 756 |
| | | H | 2301 | 1394 | 958 | 590 |
| 35 | 157 | L | 5529 | 3351 | 2303 | 1417 |
| | | M | 4343 | 2632 | 1809 | 1113 |
| | | Q | 3081 | 1867 | 1283 | 790 |
| | | H | 2361 | 1431 | 983 | 605 |
| 36 | 161 | L | 5836 | 3537 | 2431 | 1496 |
| | | M | 4588 | 2780 | 1911 | 1176 |
| | | Q | 3244 | 1966 | 1351 | 832 |
| | | H | 2524 | 1530 | 1051 | 647 |
| 37 | 165 | L | 6153 | 3729 | 2563 | 1577 |
| | | M | 4775 | 2894 | 1989 | 1224 |
| | | Q | 3417 | 2071 | 1423 | 876 |
| | | H | 2625 | 1591 | 1093 | 673 |
| 38 | 169 | L | 6479 | 3927 | 2699 | 1661 |
| | | M | 5039 | 3054 | 2099 | 1292 |
| | | Q | 3599 | 2181 | 1499 | 923 |
| | | H | 2735 | 1658 | 1139 | 701 |
| 39 | 173 | L | 6743 | 4087 | 2809 | 1729 |
| | | M | 5313 | 3220 | 2213 | 1362 |
| | | Q | 3791 | 2298 | 1579 | 972 |
| | | H | 2927 | 1774 | 1219 | 750 |
| 40 | 177 | L | 7089 | 4296 | 2953 | 1817 |
| | | M | 5596 | 3391 | 2331 | 1435 |
| | | Q | 3993 | 2420 | 1663 | 1024 |
| | | H | 3057 | 1852 | 1273 | 784 |

6. SPECIAL APPENDIX COMMAND LIST BY MODEL

- : Valid Commands • : Valid Commands (Independent Functions on Thermal/Slip) ‡ : Command where only settings are valid
 × : Invalid command (Ignored)

• Standard Commands

| Class | Commands | Class | | HSP7000 | | Model Name | | | |
|-------------------------------|----------|-------|----------|---------|------|------------|--|--|--|
| | | Set | Executed | Thermal | Slip | | | | |
| Font Style and Character Set | ESC RS F | ○ | | ○ | ‡ | | | | |
| | ESC GS t | ○ | | ○ | ○ | | | | |
| | ESC GS = | ○ | | ○ | ‡ | | | | |
| | ESC R | ○ | | ○ | ○ | | | | |
| | ESC / | ○ | | ○ | ○ | | | | |
| | ESC SP | ○ | | ○ | ○ | | | | |
| | ESC M | ○ | | • | • | | | | |
| | ESC P | ○ | | • | • | | | | |
| | ESC : | ○ | | • | • | | | | |
| ESC g | ○ | | ○ | ‡ | | | | | |
| Character Expansion Settings | ESC i | ○ | | ○ | ○ | | | | |
| | ESC W | ○ | | ○ | ○ | | | | |
| | ESC h | ○ | | ○ | ○ | | | | |
| | SO | ○ | | ○ | ○ | | | | |
| | DC4 | ○ | | ○ | ○ | | | | |
| Print Mode | ESC SO | ○ | | ○ | ○ | | | | |
| | ESC DC4 | ○ | | ○ | ○ | | | | |
| | ESC E | ○ | | ○ | ○ | | | | |
| | ESC F | ○ | | ○ | ○ | | | | |
| | ESC - | ○ | | ○ | ○ | | | | |
| | ESC _ | ○ | | ○ | ○ | | | | |
| | ESC 4 | ○ | | ○ | ○ | | | | |
| | ESC 5 | ○ | | ○ | ○ | | | | |
| | ESC GS 4 | ○ | | ‡ | ○ | | | | |
| Line Spacing | SI | ○ | | ○ | ○ | | | | |
| | DC2 | ○ | | ○ | ○ | | | | |
| | ESC RS i | ○ | | ‡ | ○ | | | | |
| | LF | | ○ | ○ | ○ | | | | |
| | CR | | ○ | ○ | ○ | | | | |
| | ESC a | | ○ | ○ | ○ | | | | |
| | ESC z | ○ | | • | • | | | | |
| | ESC 0 | ○ | | • | • | | | | |
| | ESC 1 | ○ | | • | • | | | | |
| | ESC J | | ○ | • | • | | | | |
| | ESC j | | ○ | × | ○ | | | | |
| Page Control | ESC I | | ○ | • | • | | | | |
| | ESC A | ○ | | • | • | | | | |
| | ESC 2 | ○ | | ○ | ○ | | | | |
| | ESC 3 | ○ | | × | ○ | | | | |
| | ESC y | ○ | | × | ○ | | | | |
| Horizontal Direction Position | FF | | ○ | ○ | × | | | | |
| | ESC C | ○ | | ○ | ‡ | | | | |
| | ESC C 0 | ○ | | ○ | ‡ | | | | |
| | VT | | ○ | ○ | × | | | | |
| | ESC B | ○ | | ○ | ‡ | | | | |
| Download | ESC I | ○ | | ○ | ○ | | | | |
| | ESC Q | ○ | | ○ | ○ | | | | |
| | HT | | ○ | ○ | ○ | | | | |
| | ESC D | ○ | | ○ | ○ | | | | |
| | ESC GS A | | ○ | ○ | ○ | | | | |
| | ESC GS R | | ○ | ○ | ○ | | | | |
| Download | ESC GS a | ○ | | ○ | ○ | | | | |
| | ESC & | ○ | | ○ | ○ | | | | |
| | ESC % | ○ | | ○ | ○ | | | | |

| Class | Commands | Class | | HSP7000 | | Model Name | | | |
|-----------------------|---------------|-------|----------|---------|------|------------|--|--|--|
| | | Set | Executed | Thermal | Slip | | | | |
| | | | | | | | | | |
| Bit Image Graphics | ESC K | o | | o | o | | | | |
| | ESC L | o | | o | o | | | | |
| | ESC k | o | | o | x | | | | |
| | ESC X | o | | o | x | | | | |
| | ESC ^ | o | | x | o | | | | |
| Logo | ESC FS q | o | | o | o | | | | |
| | ESC FS p | | o | o | o | | | | |
| | ESC RS L | | o | o | o | | | | |
| Bar Codes | ESC b | o | | o | o | | | | |
| Cutter Control | ESC d | | o | o | x | | | | |
| External Device Drive | ESC BEL | o | | o | o | | | | |
| | BEL | | o | o | o | | | | |
| | FS | | o | o | o | | | | |
| | SUB | | o | o | o | | | | |
| | EM | | o | o | o | | | | |
| | ESC GS BEL | | o | o | o | | | | |
| | ESC GS EM DC1 | o | | o | o | | | | |
| | ESC GS EM DC2 | | o | o | o | | | | |
| Print Setting | ESC RS d | o | | o | ‡ | | | | |
| | ESC RS r | o | | o | ‡ | | | | |
| Status | ESC RS a | o | | o | o | | | | |
| | ESC ACK SOH | | o | o | o | | | | |
| | ENQ | | o | o | o | | | | |
| | EOT | | o | o | o | | | | |
| | ETB | | o | o | o | | | | |
| | ESC RS E | | o | o | o | | | | |
| Kanji Character | ESC p | o | | o | o | | | | |
| | ESC q | o | | o | o | | | | |
| | ESC \$ | o | | o | o | | | | |
| | ESC s | o | | o | o | | | | |
| | ESC t | o | | o | o | | | | |
| | ESC r | o | | o | o | | | | |
| | ESC u n | o | | ‡ | o | | | | |
| | ESC x n | o | | ‡ | o | | | | |
| ESC w n | o | | ‡ | o | | | | | |
| Others | RS | | o | o | o | | | | |
| | CAN | | o | o | o | | | | |
| | ESC @ | | o | o | o | | | | |
| | ESC U | o | | ‡ | o | | | | |
| | ESC GS # m | o | | o | o | | | | |
| | ESC # @ | o | | o | o | | | | |
| | ESC # N ? | | o | o | o | | | | |
| | ESC # * | | o | o | o | | | | |
| | ESC ? | o | | o | o | | | | |
| | DC3 | o | | o | o | | | | |
| DC1 | o | | o | o | | | | | |

• Raster related commands

| Class | Commands | Class | | HSP7000 | | Model Name | | | |
|-----------|-----------------|-------|----------|---------|------|------------|--|--|--|
| | | Set | Executed | Thermal | Slip | | | | |
| | | | | | | | | | |
| Raster | ESC * r R | | o | o | x | | | | |
| | ESC * r A | | o | o | x | | | | |
| | ESC * r B | | o | o | x | | | | |
| | ESC * r C | | o | o | x | | | | |
| | ESC * r D | | o | o | x | | | | |
| | ESC * r E | o | | o | x | | | | |
| | ESC * r F | o | | o | x | | | | |
| | ESC * r P | o | | o | x | | | | |
| | ESC * r Q | o | | o | x | | | | |
| | ESC * r m l | o | | o | x | | | | |
| | ESC * r m r | o | | o | x | | | | |
| | ESC * r T | o | | o | x | | | | |
| | ESC * r K | o | | o | x | | | | |
| | b n1 n2 d1...dk | | o | o | x | | | | |
| | k n1 n2 d1...dk | | o | o | x | | | | |
| | ESC * r Y | | o | o | x | | | | |
| | ESC FF NUL | | o | o | x | | | | |
| | ESC FF EOT | | o | o | x | | | | |
| ESC * r N | | o | o | x | | | | | |
| ESC * r V | | o | o | x | | | | | |

• Black mark related commands

| Class | Commands | Class | | HSP7000 | | Model Name | | | |
|-----------------------------|----------|-------|----------|---------|------|------------|--|--|--|
| | | Set | Executed | Thermal | Slip | | | | |
| | | | | | | | | | |
| Black Mark Related Commands | ESC d | | o | o | x | | | | |
| | FF | | o | o | x | | | | |
| | ESC C | o | | o | x | | | | |
| | ESC C 0 | o | | o | x | | | | |
| | VT | | o | o | x | | | | |
| | ESC B | o | | o | x | | | | |

• 2-Color Printing Related Commands

| Class | Commands | Class | | HSP7000 | | Model Name | | | |
|-----------------------------------|----------|-------|----------|---------|------|------------|--|--|--|
| | | Set | Executed | Thermal | Slip | | | | |
| | | | | | | | | | |
| 2-Color Printing Related Commands | ESC RS c | o | | o | ± | | | | |
| | ESC RS C | o | | o | ± | | | | |
| | ESC 4 | o | | o | o | | | | |
| | ESC 5 | o | | o | o | | | | |
| | ESC RS d | o | | o | ± | | | | |
| | ESC RS r | o | | o | ± | | | | |
| | ESC FS q | o | | o | o | | | | |
| | ESC FS p | | o | o | o | | | | |

• Mark Commands

| Class | Commands | Class | | HSP7000 | | Model Name | | | |
|---------------|------------|-------|----------|---------|------|------------|--|--|--|
| | | Set | Executed | Thermal | Slip | | | | |
| | | | | | | | | | |
| Mark Commands | ESC GS * 0 | | o | o | x | | | | |
| | ESC GS * 1 | o | | o | ± | | | | |
| | ESC GS * 2 | o | | o | ± | | | | |
| | ESC GS * W | | o | o | o | | | | |
| | ESC GS * C | | o | o | o | | | | |

• Auto Logo Commands

| Class | Commands | Class | | HSP7000 | | Model Name | | | |
|------------|------------|-------|----------|---------|------|------------|--|--|--|
| | | Set | Executed | Thermal | Slip | | | | |
| | | | | | | | | | |
| Auto Logo | ESC GS / W | | ○ | ○ | ○ | | | | |
| | ESC GS / C | | ○ | ○ | ○ | | | | |
| | ESC GS / 1 | ○ | | ○ | ‡ | | | | |
| | ESC GS / 2 | ○ | | ○ | ‡ | | | | |
| | ESC GS / 3 | ○ | | ○ | ‡ | | | | |
| | ESC GS / 4 | ○ | | ○ | ‡ | | | | |
| | ESC GS / 5 | ○ | | ○ | ‡ | | | | |
| ESC GS / 6 | ○ | | ○ | ○ | ‡ | | | | |

• PDF417 Commands

| Class | Commands | Class | | HSP7000 | | Model Name | | | |
|--------|--------------|-------|----------|---------|------|------------|--|--|--|
| | | Set | Executed | Thermal | Slip | | | | |
| | | | | | | | | | |
| PDF417 | ESC GS x S 0 | ○ | | ○ | ‡ | | | | |
| | ESC GS x S 1 | ○ | | ○ | ‡ | | | | |
| | ESC GS x S 2 | ○ | | ○ | ‡ | | | | |
| | ESC GS x S 3 | ○ | | ○ | ‡ | | | | |
| | ESC GS x D | ○ | | ○ | ‡ | | | | |
| | ESC GS x P | | ○ | ○ | × | | | | |
| | ESC GS x I | | ○ | ○ | ○ | | | | |

• Print Start Trigger Control Commands

| Class | Commands | Class | | HSP7000 | | Model Name | | | |
|--|------------|-------|----------|---------|------|------------|--|--|--|
| | | Set | Executed | Thermal | Slip | | | | |
| | | | | | | | | | |
| Print Start- ing Trigger Control | ESC GS g 0 | | ○ | ○ | × | | | | |
| | ESC GS g 1 | ○ | | ○ | ‡ | | | | |

• QR Code Commands

| Class | Commands | Class | | Model Name | | | | |
|----------|--------------|-------|----------|------------|------|--|--|--|
| | | Set | Executed | HSP7000 | | | | |
| | | | | Thermal | Slip | | | |
| QR Codes | ESC GS y S 0 | ○ | | ○ | ⊕ | | | |
| | ESC GS y S 1 | ○ | | ○ | ⊕ | | | |
| | ESC GS y S 2 | ○ | | ○ | ⊕ | | | |
| | ESC GS y D 1 | ○ | | ○ | ⊕ | | | |
| | ESC GS y D 2 | ○ | | ○ | ⊕ | | | |
| | ESC GS y P | | ○ | ○ | × | | | |
| | ESC GS y I | | ○ | ○ | ○ | | | |

• Page Function Commands

| Class | Commands | Class | | Model Name | | | | |
|---------------|------------|-------|----------|------------|------|--|--|--|
| | | Set | Executed | HSP7000 | | | | |
| | | | | Thermal | Slip | | | |
| Page Function | ESC GS h 0 | ○ | | ○ | ⊕ | | | |
| | ESC GS h 1 | ○ | | ○ | ⊕ | | | |

• Slip/Validation Function Commands

| Class | Commands | Class | | Model Name | | | | |
|--------------------------|----------|-------|----------|------------|------|--|--|--|
| | | Set | Executed | HSP7000 | | | | |
| | | | | Thermal | Slip | | | |
| Slip/Validation Function | ESC SI | ○ | | × | × | | | |
| | ESC FF | | ○ | × | ○ | | | |
| | ESC VT | ○ | | × | × | | | |
| | ESC EM | ○ | | × | ○ | | | |

• Page Mode Commands

| Class | Commands | Class | | Model Name | | | | |
|-----------|----------|-------|----------|------------|------|--|--|--|
| | | Set | Executed | HSP7000 | | | | |
| | | | | Thermal | Slip | | | |
| Page Mode | FF | | ○ | × | ○ | | | |
| | ESC n | | ○ | × | ○ | | | |
| | ESC ! | | ○ | × | ○ | | | |
| | ESC * | ○ | | × | ○ | | | |
| | ESC T | ○ | | × | ○ | | | |

• Station Selection Command

| Class | Commands | Class | | Model Name | | | | |
|-------------------|----------|-------|----------|------------|------|--|--|--|
| | | Set | Executed | HSP7000 | | | | |
| | | | | Thermal | Slip | | | |
| Station Selection | ESC + A | | ○ | ○ | ○ | | | |

• Presenter Commands

| Class | Commands | Class | | Model Name | | | | |
|-----------|-----------|-------|----------|------------|------|--|--|--|
| | | Set | Executed | HSP7000 | | | | |
| | | | | Thermal | Slip | | | |
| Presenter | ESC SYN 0 | | ○ | × | × | | | |
| | ESC SYN 1 | ○ | | × | × | | | |
| | ESC SYN 3 | | ○ | × | × | | | |
| | ESC SYN 4 | | ○ | × | × | | | |

• MICR Commands

| Class | Commands | Class | | Model Name | | | | |
|-------|----------|-------|----------|------------|------|--|--|--|
| | | Set | Executed | HSP7000 | | | | |
| | | | | Thermal | Slip | | | |
| MICR | ESC FS M | | ○ | × | ○ | | | |

7. SPECIAL APPENDIX COMMAND FUNCTION LIST

7-1) HSP7000

7-1-1) Setting Command List

| Type | Command | Execution Station Thermal, Slip, Validation | Thermal | | Slip | | Validation | |
|---------------------------------|----------|---|---------|---|--------------------------|--|--------------------------|--|
| | | | Line | Other Precautions | Line/Page | Other Precautions | Line/Page | Other Precautions |
| Font Style and Character Set | ESC RS F | Shared Only valid for thermal | Valid | | Invalid | Valid after switch to thermal | Invalid | Valid after switch to thermal |
| | ESC GS t | Shared | Valid | Ignored for DBCS setting & for models with Kanji characters | Valid Shared | Ignored for DBCS setting & for models with Kanji characters | Valid Shared | Ignored for DBCS setting & for models with Kanji characters |
| | ESC GS = | Independent Station selection command dependent Only valid for thermal | Valid | | Invalid | Valid after switch to thermal | Invalid | Valid after switch to thermal |
| | ESC R | Shared | Valid | | Valid Shared | | Valid Shared | |
| | ESC / | Shared | Valid | | Valid Shared | | Valid Shared | |
| | ESC SP | Shared | Valid | Shared with Slip/Validation a Line Mode | Valid For each Line/Page | Line/Page mode settings Independent Line Mode: Shared with Thermal/Validation a Line Mode Page Mode: Sared with Validation a Page Mode | Valid For each Line/Page | Line/Page mode settings Independent Line Mode: Shared with Thermal/Validation a Line Mode Page Mode: Sared with Validation a Page Mode |
| | ESC M | Shared | Valid | Specify 12 dot pitch | Valid only Line | Line Mode: 7x9 Selection Page Mode: 5x9 Fixed Valid after switch to line mode | Valid only Line | Line Mode: 7x9 Selection Page Mode: 5x9 Fixed Valid after switch to line mode |
| | ESC P | Shared | Valid | Specify 15 dot pitch | Valid only Line | Line mode: 5x9 (2P-1) selection Page Mode: 5x9 Fixed Valid after switch to line mode | Valid only Line | Line mode: 5x9 (2P-1) selection Page mode: 5x9 Fixed Valid after switch to line mode |
| | ESC : | Shared | Valid | Specify 16 dot pitch | Valid only Line | Line mode: 5x9 (3P-1) selection Page mode: 5x9 Fixed Valid after switch to line mode | Valid only Line | Line mode: 5x9 (3P-1) selection Page mode: 5x9 Fixed Valid after switch to line mode |
| | ESC g | Shared Only valid for thermal | Valid | | Invalid | Valid after switch to thermal | Invalid | Valid after switch to thermal |
| | ESC 6 | Shared | Invalid | Two bytes ignored | Invalid | Two bytes ignored | Invalid | Two bytes ignored |
| | ESC 7 | Shared | Invalid | Two bytes ignored | Invalid | Two bytes ignored | Invalid | Two bytes ignored |
| Character Expansion | ESC i | Shared | Valid | Expanded by parameter n1, n2 After switch slip/validation, fixed at 2x even with expansion enabled | Valid Shared | Fixed at 2x when parameters n1, n2 are higher than 1. Expansion valid by parameter after switch to thermal | Valid Shared | Fixed at 2x when parameters n1, n2 are higher than 1. Expansion valid by parameter after switch to thermal |
| | ESC W | Shared | Valid | Expanded by parameter n After switch slip/validation, fixed at 2x even with expansion enabled | Valid Shared | Fixed at 2x when parameter is higher than 1. Expansion valid by parameter after switch to thermal | Valid Shared | Fixed at 2x when parameter is higher than 1. Expansion valid by parameter after switch to thermal |
| | ESC h | Shared | Valid | Expanded by parameter n After switch slip/validation, fixed at 2x even with expansion enabled | Valid Shared | Fixed at 2x when parameter is higher than 1. Expansion valid by parameter after switch to thermal | Valid Shared | Fixed at 2x when parameter is higher than 1. Expansion valid by parameter after switch to thermal |
| | SO | Shared | Valid | | Valid Shared | | Valid Shared | |
| | DC4 | Shared | Valid | | Valid Shared | | Valid Shared | |
| | ESC SO | Shared | Valid | | Valid Shared | | Valid Shared | |
| | ESC DC4 | Shared | Valid | | Valid Shared | | Valid Shared | |

| Type | Command | Execution Station Thermal, Slip, Validation | Thermal | | Slip | | Validation | |
|-------------------------------|-------------------------------|---|---------------------------------------|---|--|--|--|--|
| | | | Line | Other Precautions | Line/Page | Other Precautions | Line/Page | Other Precautions |
| Adornment | ESC E | Shared | Valid | | Valid Shared Invalid | | Valid Shared Invalid | |
| | ESC G | Shared | Invalid | Two bytes ignored | | Two bytes ignored | | Two bytes ignored |
| | ESC F | Shared | Valid | | Valid Shared Invalid | | Valid Shared Invalid | |
| | ESC H | Shared | Invalid | Two bytes ignored | | Two bytes ignored | | Two bytes ignored |
| | ESC - | Shared | Valid | | Valid Shared Valid | | Valid Shared Valid | |
| | ESC _ | Shared | Valid | | Valid Shared Valid | | Valid Shared Valid | |
| | ESC 4 | Shared | Valid | Sets white/black inverted printing After switch to slip/validation, red-black swithing function printing valid | Valid Shared | Sets red/black substitute function Valid After switch to thermal, white-black inversion printing valid | Valid Shared | Sets red/black substitute function Valid After switch to thermal, white-black inversion printing valid |
| | ESC 5 | Shared | Valid | Cancel white/black inverted printing After switch to slip/validation, red-black swithing function printing canceled | Valid Shared | Cancel white/black inverted printing After switch to slip, red-black swithing function printing canceled | Valid Shared | Cancel white/black inverted printing After switch to validation, red-black swithing function printing canceled |
| | ESC GS 4 | Shared Slip, Validation valid | Invalid | Valid after switch to slip/validation | Valid Shared | | Valid Shared | |
| | SI | Shared | Valid | | Valid only Line | Page mode: Valid after switch to line mode | Valid only Line | Page mode: Valid after switch to line mode |
| DC2 | Shared | Valid | | Valid only Line | Page Mode: Valid after switch to line mode | Valid only Line | Page Mode: Valid after switch to line mode | |
| ESC RS i | Shared Slip, Validation valid | Invalid | Valid after switch to slip/validation | Valid only Line | Page mode: Valid after switch to line mode | Valid only Line | Page mode: Valid after switch to line mode | |
| Line spacing | ESC z | Independent Station selection command dependent | Valid | | Valid For each Line/Page | Line/Page mode settings Independent | Valid For each Line/Page | Line/Page mode settings Independent |
| | ESC 0 | Independent Station selection command dependent | Valid | | Valid For each Line/Page | Line/Page mode settings Independent | Valid For each Line/Page | Line/Page mode settings Independent |
| | ESC 1 | Independent Station selection command dependent | Valid | | Valid For each Line/Page | Line/Page mode settings Independent | Valid For each Line/Page | Line/Page mode settings Independent |
| | ESC A | Independent Station selection command dependent | Valid | | Valid For each Line/Page | Line/Page mode settings Independent | Valid For each Line/Page | Line/Page mode settings Independent |
| | ESC 2 | Independent Station selection command dependent | Valid | | Valid For each Line/Page | Line/Page mode settings Independent | Valid For each Line/Page | Line/Page mode settings Independent |
| | ESC 3 | Independent Station selection command dependent | Invalid | Three bytes ignored | Valid For each Line/Page | Line/Page mode settings Independent | Valid For each Line/Page | Line/Page mode settings Independent |
| | ESC y | Independent Station selection command dependent | Invalid | Three bytes ignored | Valid For each Line/Page | Line/Page mode settings Independent | Valid For each Line/Page | Line/Page mode settings Independent |
| Page Control | ESC C | Shared Only valid for thermal | Valid | | Invalid | Valid after switch to thermal | Invalid | Valid after switch to thermal |
| | ESC C 0 | Shared Only valid for thermal | Valid | | Invalid | Valid after switch to thermal | Invalid | Valid after switch to thermal |
| | ESC c | Shared Only valid for thermal | Valid | | Invalid | Valid after switch to thermal | Invalid | Valid after switch to thermal |
| | ESC B | Shared Only valid for thermal | Valid | | Invalid | Valid after switch to thermal | Invalid | Valid after switch to thermal |
| | ESC N | Shared | Invalid | Three bytes ignored | Invalid | Three bytes ignored | Invalid | Three bytes ignored |
| | ESC O | Shared | Invalid | Two bytes ignored | Invalid | Two bytes ignored | Invalid | Two bytes ignored |
| Horizontal Direction Position | ESC I | Independent Station selection command dependent | Valid | | Valid only Line | Page mode: Valid after switch to line mode | Valid only Line | Page mode: Valid after switch to line mode |
| | ESC Q | Independent Station selection command dependent | Valid | | Valid only Line | Page mode: Valid after switch to line mode | Valid only Line | Page mode: Valid after switch to line mode |
| | ESC D | Shared | Valid | | Valid Shared Valid | | Valid Shared Valid | |
| | ESC GS a | Shared | Valid | | Valid only Line | Page mode: Valid after switch to line mode | Valid only Line | Page mode: Valid after switch to line mode |

| Type | Command | Execution Station Thermal, Slip, Validation | Thermal | | Slip | | Validation | |
|-----------------------|---------------|---|---------|---|--------------------------|---|--------------------------|---|
| | | | Line | Other Precautions | Line/Page | Other Precautions | Line/Page | Other Precautions |
| Download | ESC & | Shared | Valid | | Valid Shared | Shared with validation | Valid Shared | Shared with slip |
| | ESC % | Shared | Valid | | Valid Shared | | Valid Shared | |
| Logos | ESC FS q | Shared | Valid | | Valid Shared | | Valid Shared | |
| External Drive Device | ESC BEL | Shared | Valid | | Valid Shared | | Valid Shared | |
| | ESC GS EM DC1 | Shared | Valid | | Valid Shared | | Valid Shared | |
| Print Setting | ESC RS d | Shared Only valid for thermal | Valid | | Invalid | Valid after switch to thermal | Invalid | Valid after switch to thermal |
| | ESC RS r | Shared Only valid for thermal | Valid | | Invalid | Valid after switch to thermal | Invalid | Valid after switch to thermal |
| Status | ESC RS a | Shared | Valid | | Valid Shared | | Valid Shared | |
| Kanji Character | ESC p | Shared | Valid | | Valid Shared | Page Mode: Valid only in double-density page mode For standard mode, valid after switching to double-densitymode/line mode | Valid Shared | Page Mode: Valid only in double-density page mode For standard mode, valid after switching to double-densitymode/line mode |
| | ESC q | Shared | Valid | | Valid Shared | Page Mode: Valid only in double-density page mode For standard mode, valid after switching to double-densitymode/line mode | Valid Shared | Page Mode: Valid only in double-density page mode For standard mode, valid after switching to double-densitymode/line mode |
| | ESC \$ | Shared | Valid | | Valid Shared | Page Mode: Valid only in double-density page mode For standard mode, valid after switching to double-densitymode/line mode | Valid Shared | Page Mode: Valid only in double-density page mode For standard mode, valid after switching to double-densitymode/line mode |
| | ESC s | Shared | Valid | Shared with Slip/Validation a Line Mode setting | Valid For each Line/Page | Line/Page mode settings Independent Line Mode: Shared with Validation setting | Valid For each Line/Page | Line/Page mode settings Independent Line Mode: Shared with Validation setting |
| | ESC t | Shared | Valid | Shared with Slip/Validation a Line Mode setting | Valid For each Line/Page | Line/Page mode settings Independent Line Mode: Shared with Validation setting | Valid For each Line/Page | Line/Page mode settings Independent Line Mode: Shared with Validation setting |
| | ESC r | Independent Station selection command dependent | Valid | | Valid Shared | Shared with validation | Valid Shared | Shared with slip |
| | ESC u | Shared Slip, Validation valid | Invalid | Valid after switch to slip/validation | Valid Shared | Page Mode: Valid only in double-density page mode For standard mode, valid after switching to double-densitymode/line mode | Valid Shared | Page Mode: Valid only in double-density page mode For standard mode, valid after switching to double-densitymode/line mode |
| | ESC x | Shared Slip, Validation valid | Invalid | Valid after switch to slip/validation | Valid Shared | Page Mode: Valid only in double-density page mode For standard mode, valid after switching to double-densitymode/line mode | Valid Shared | Page Mode: Valid only in double-density page mode For standard mode, valid after switching to double-densitymode/line mode |
| | ESC w | Shared Slip, Validation valid | Invalid | Valid after switch to slip/validation | Valid Shared | Page Mode: Valid only in double-density page mode For standard mode, valid after switching to double-densitymode/line mode | Valid Shared | Page Mode: Valid only in double-density page mode For standard mode, valid after switching to double-densitymode/line mode |
| | ESC U | Shared Slip, Validation valid | Invalid | Valid after switch to slip/validation | Valid For each Line/Page | Line/Page mode settings Independent Shared with validation | Valid For each Line/Page | Line/Page mode settings Independent Shared with slip |
| Others | ESC e | Shared | Valid | | Valid Shared | | Valid Shared | |
| | ESC f | Shared | Valid | | Valid Shared | | Valid Shared | |

| Type | Command | Execution Station Thermal, Slip, Validation | Thermal | | Slip | | Validation | |
|--------------------|--------------|---|---------|-------------------|--------------|--|--------------|--|
| | | | Line | Other Precautions | Line/Page | Other Precautions | Line/Page | Other Precautions |
| Macro | ESC GS + | Shared | Valid | | Valid Shared | | Valid Shared | |
| Raster Mode | ESC * r E | Independent Station selection command dependent Only valid for thermal | Valid | | Invalid | Data received and discarded up to <NUL>. | Invalid | Data received and discarded up to <NUL>. |
| | ESC * r F | Independent Station selection command dependent Only valid for thermal | Valid | | Invalid | Data received and discarded up to <NUL>. | Invalid | Data received and discarded up to <NUL>. |
| | ESC * r P | Independent Station selection command dependent Only valid for thermal | Valid | | Invalid | Data received and discarded up to <NUL>. | Invalid | Data received and discarded up to <NUL>. |
| | ESC * r Q | Independent Station selection command dependent Only valid for thermal | Valid | | Invalid | Data received and discarded up to <NUL>. | Invalid | Data received and discarded up to <NUL>. |
| | ESC * r m l | Independent Station selection command dependent Only valid for thermal | Valid | | Invalid | Data received and discarded up to <NUL>. | Invalid | Data received and discarded up to <NUL>. |
| | ESC * r m r | Independent Station selection command dependent Only valid for thermal | Valid | | Invalid | Data received and discarded up to <NUL>. | Invalid | Data received and discarded up to <NUL>. |
| | ESC * r T | Independent Station selection command dependent Only valid for thermal | Valid | | Invalid | Data received and discarded up to <NUL>. | Invalid | Data received and discarded up to <NUL>. |
| | ESC * r K | Independent Station selection command dependent Only valid for thermal | Valid | | Invalid | Data received and discarded up to <NUL>. | Invalid | Data received and discarded up to <NUL>. |
| USB Related | ESC ## W | Shared | Valid | | Valid Shared | | Valid Shared | |
| 2-Color Printing | ESC RS c | Shared Only valid for thermal | Valid | | Invalid | Valid after switch to thermal | Invalid | Valid after switch to thermal |
| | ESC RS C | Shared Only valid for thermal | Valid | | Invalid | Valid after switch to thermal | Invalid | Valid after switch to thermal |
| Mark Com- mands | ESC GS * 1 | Shared Only valid for thermal | Valid | | Invalid | Valid after switch to thermal | Invalid | Valid after switch to thermal |
| | ESC GS * 2 | Shared Only valid for thermal | Valid | | Invalid | Valid after switch to thermal | Invalid | Valid after switch to thermal |
| Auto Logo | ESC GS / 1 | Shared Only valid for thermal | Valid | | Invalid | Valid after switch to thermal | Invalid | Valid after switch to thermal |
| | ESC GS / 2 | Shared Only valid for thermal | Valid | | Invalid | Valid after switch to thermal | Invalid | Valid after switch to thermal |
| | ESC GS / 3 | Shared Only valid for thermal | Valid | | Invalid | Valid after switch to thermal | Invalid | Valid after switch to thermal |
| | ESC GS / 4 | Shared Only valid for thermal | Valid | | Invalid | Valid after switch to thermal | Invalid | Valid after switch to thermal |
| | ESC GS / 5 | Shared Only valid for thermal | Valid | | Invalid | Valid after switch to thermal | Invalid | Valid after switch to thermal |
| | ESC GS / 6 | Shared Only valid for thermal | Valid | | Invalid | Valid after switch to thermal | Invalid | Valid after switch to thermal |
| User ID | ESC GS % 0 | Shared | Valid | | Valid Shared | | Valid Shared | |
| PDF 417 | ESC GS x S 0 | Shared Only valid for thermal | Valid | | Invalid | Valid after switch to thermal | Invalid | Valid after switch to thermal |
| | ESC GS x S 1 | Shared Only valid for thermal | Valid | | Invalid | Valid after switch to thermal | Invalid | Valid after switch to thermal |
| | ESC GS x S 2 | Shared Only valid for thermal | Valid | | Invalid | Valid after switch to thermal | Invalid | Valid after switch to thermal |
| | ESC GS x S 3 | Shared Only valid for thermal | Valid | | Invalid | Valid after switch to thermal | Invalid | Valid after switch to thermal |
| | ESC GS x D | Shared Only valid for thermal | Valid | | Invalid | Valid after switch to thermal | Invalid | Valid after switch to thermal |

| Type | Command | Execution Station Thermal, Slip, Validation | Thermal | | Slip | | Validation | |
|---------------------|--------------|---|---------|--|-----------------|--|-----------------|--|
| | | | Line | Other Precautions | Line/Page | Other Precautions | Line/Page | Other Precautions |
| Printer Driver | ESC RS A | Independent Station selection command dependent | Valid | | Valid only Line | Page Mode: Valid after switch to line mode | Valid only Line | Page Mode: Valid after switch to line mode |
| | ESC RS m | Shared Only valid for thermal | Valid | | Invalid | Valid after switch to thermal | Invalid | Valid after switch to thermal |
| Print Start Trigger | ESC GS g 1 | Shared Only valid for thermal | Valid | | Invalid | Valid after switch to thermal | Invalid | Valid after switch to thermal |
| QR Codes | ESC GS y S 0 | Shared Only valid for thermal | Valid | | Invalid | Valid after switch to thermal | Invalid | Valid after switch to thermal |
| | ESC GS y S 1 | Shared Only valid for thermal | Valid | | Invalid | Valid after switch to thermal | Invalid | Valid after switch to thermal |
| | ESC GS y S 2 | Shared Only valid for thermal | Valid | | Invalid | Valid after switch to thermal | Invalid | Valid after switch to thermal |
| | ESC GS y D 1 | Shared Only valid for thermal | Valid | | Invalid | Valid after switch to thermal | Invalid | Valid after switch to thermal |
| | ESC GS y D 2 | Shared Only valid for thermal | Valid | | Invalid | Valid after switch to thermal | Invalid | Valid after switch to thermal |
| Page Function | ESC GS h 0 | Shared Only valid for thermal | Valid | | Invalid | Valid after switch to thermal | Invalid | Valid after switch to thermal |
| | ESC GS h 1 | Shared Only valid for thermal | Valid | | Invalid | Valid after switch to thermal | Invalid | Valid after switch to thermal |
| Slip Function | ESC SI | Shared | Invalid | Three bytes ignored | Invalid | Three bytes ignored | Invalid | Three bytes ignored |
| | ESC VT | Shared Slip, Validation valid | Invalid | Four bytes ignored | Invalid | Four bytes ignored | Invalid | Four bytes ignored |
| | ESC EM | Shared Slip/Validation Valid | Invalid | Valid after switch to slip/validation | Valid Shared | | Valid Shared | |
| | ESC US | Shared Slip, Validation valid | Invalid | Valid after switch to slip/validation | Valid Shared | | Valid Shared | |
| Page Mode | ESC n | Independent Station selection command dependent | Invalid | Two bytes ignored | Valid only Line | Page Mode: Two bytes ignored | Valid only Line | Page Mode: Two bytes ignored |
| | ESC ! | Independent Station selection command dependent | Invalid | Two bytes ignored | Valid Page only | Line Mode: Two bytes ignored | Valid Page only | Line Mode: Two bytes ignored |
| | ESC * | Independent Station selection command dependent | Valid | Raster mode related Ten bytes ignored | Valid Page only | Line Mode: Valid after switch to page mode | Valid Page only | Line Mode: Valid after switch to page mode |
| | ESC T | Independent Station selection command dependent | Invalid | Three bytes ignored | Valid Page only | Line Mode: Valid after switch to page mode | Valid Page only | Line Mode: Valid after switch to page mode |
| Presenter | ESC SYN 1 | Shared | Invalid | Four bytes ignored | Invalid | Four bytes ignored | Invalid | Four bytes ignored |
| | ESC SYN 2 | Shared | Invalid | Four bytes ignored | Invalid | Four bytes ignored | Invalid | Four bytes ignored |

7-1-2) Execution Command List

| Type | Command | Execution Station Thermal, Slip, Validation | Thermal | | Slip | | Validation | |
|-------------------------------|----------------|--|---------|---|-----------------------------|---|-----------------------------|---|
| | | | Line | Other Precautions | Line/Page | Other Precautions | Line/Page | Other Precautions |
| Line spacing | LF | Independent Station selection command dependent | Valid | | Valid For each Line/Page | | Valid For each Line/Page | |
| | CR | Independent Station selection command dependent | Valid | | Valid For each Line/Page | | Valid For each Line/Page | |
| | GS | Independent Station selection command dependent | Invalid | One byte ignored | Invalid | One byte ignored | Invalid | One byte ignored |
| | ESC a | Independent Station selection command dependent | Valid | | Valid For each Line/Page | | Valid For each Line/Page | |
| | ESC J | Independent Station selection command dependent | Valid | | Valid For each Line/Page | | Valid For each Line/Page | |
| | ESC j | Independent Station selection command dependent | Invalid | Three bytes ignored | Valid For each Line/Page | | Valid For each Line/Page | |
| | ESC I | Independent Station selection command dependent | Valid | | Valid For each Line/Page | | Valid For each Line/Page | |
| Page Control | FF (Line Mode) | Independent Station selection command dependent | Valid | | Invalid | One byte ignored | Invalid | One byte ignored |
| | VT | Independent Station selection command dependent | Valid | | Invalid | One byte ignored | Invalid | One byte ignored |
| Horizontal Direction Position | HT | Independent Station selection command dependent | Valid | | Valid For each Line/Page | | Valid For each Line/Page | |
| | ESC GS A | Independent Station selection command dependent | Valid | | Valid For each Line/Page | | Valid For each Line/Page | |
| | ESC GS R | Independent Station selection command dependent | Valid | | Valid For each Line/Page | | Valid For each Line/Page | |
| | ESC HT | Independent Station selection command dependent | Invalid | Four bytes ignored | Invalid | Four bytes ignored | Invalid | Four bytes ignored |
| Bit Image | ESC K | Independent Station selection command dependent | Valid | | Valid For each Line/Page | | Valid For each Line/Page | |
| | ESC L | Independent Station selection command dependent | Valid | | Valid For each Line/Page | | Valid For each Line/Page | |
| | ESC k | Independent Station selection command dependent | Valid | | Invalid | All data for the amount of the counter received and discarded | Invalid | All data for the amount of the counter received and discarded |
| | ESC X | Independent Station selection command dependent | Valid | | Invalid | All data for the amount of the counter received and discarded | Invalid | All data for the amount of the counter received and discarded |
| | ESC ^ | Independent Station selection command dependent | Invalid | All data for the amount of the counter received and discarded | Valid For each Line/Page | | Valid For each Line/Page | |
| Logo | ESC FS p | Independent Station selection command dependent | Valid | | Valid For each Line/Page | | Valid For each Line/Page | |
| | ESC RS L | Independent Station selection command dependent | Valid | | Valid only Line | Page Mode: Four bytes ignored | Valid only Line | Page Mode: Four bytes ignored |
| Bar Codes | ESC b | Independent Station selection command dependent | Valid | | Valid only Line | Line Mode: Data received and discarded up to <RS> for unsupported bar codes Page Mode: Data received and discarded up to <RS> | Valid only Line | Line Mode: Data received and discarded up to <RS> for unsupported bar codes Page Mode: Data received and discarded up to <RS> |
| Cutter Control | ESC d | Independent Station selection command dependent | Valid | | Invalid | Three bytes ignored | Invalid | Three bytes ignored |

| Type | Command | Execution Station Thermal, Slip, Validation | Thermal | | Slip | | Validation | |
|-----------------------|----------------------|---|---------|---------------------|--------------------------|--------------------------------|--------------------------|--------------------------------|
| | | | Line | Other Precautions | Line/Page | Other Precautions | Line/Page | Other Precautions |
| External Device Drive | BEL | Shared | Valid | | Valid Shared | | Valid Shared | |
| | FS | Shared | Valid | | Valid Shared | | Valid Shared | |
| | SUB | Shared | Valid | | Valid Shared | | Valid Shared | |
| | EM | Shared | Valid | | Valid Shared | | Valid Shared | |
| | ESC GS BEL | Shared | Valid | | Valid Shared | | Valid Shared | |
| | ESC GS EM DC2 | Shared | Valid | | Valid Shared | | Valid Shared | |
| Status | ESC ACK SOH | Shared | Valid | | Valid Shared | | Valid Shared | |
| | ENQ | Shared | Valid | | Valid Shared | | Valid Shared | |
| | EOT | Shared | Valid | | Valid Shared | | Valid Shared | |
| | ETB | Shared | Valid | | Valid Shared | | Valid Shared | |
| | ESC RS E | Shared | Valid | | Valid Shared | | Valid Shared | |
| Others | RS | Shared | Valid | | Valid Shared | | Valid Shared | |
| | CAN | Shared | Valid | | Valid Shared | | Valid Shared | |
| | ESC @ | Shared | Valid | | Valid Shared | | Valid Shared | |
| | ESC GS # | Shared | Valid | | Valid Shared | | Valid Shared | |
| | ESC # N | Shared | Invalid | Ignored up to <NUL> | Invalid | Ignored up to <NUL> | Invalid | Ignored up to <NUL> |
| | ESC # @ | Shared | Valid | | Valid Shared | | Valid Shared | |
| | ESC # N ? | Shared | Valid | | Valid Shared | | Valid Shared | |
| | ESC # * | Shared | Valid | | Valid Shared | | Valid Shared | |
| | ESC ? | Shared | Valid | | Valid Shared | | Valid Shared | |
| | DC3 | Shared | Valid | | Valid Shared | | Valid Shared | |
| | DC1 | Shared | Valid | | Valid Shared | | Valid Shared | |
| | ESC GS r | Shared | Valid | | Invalid | Six bytes ignored | Invalid | Six bytes ignored |
| | ESC ETB | Independent Station selection command dependent | Invalid | Three bytes ignored | Valid only Line | Page Mode: Three bytes ignored | Valid only Line | Page Mode: Three bytes ignored |
| Macro | ESC m | Independent Station selection command dependent | Valid | | Valid For each Line/Page | | Valid For each Line/Page | |
| | Initialization Macro | Shared | Valid | | Valid Shared | | Valid Shared | |
| Raster Mode | ESC * r R | Independent Station selection command dependent Only valid for thermal | Valid | | Invalid | Four bytes ignored | Invalid | Four bytes ignored |
| | ESC * r A | Independent Station selection command dependent Only valid for thermal | Valid | | Invalid | Four bytes ignored | Invalid | Four bytes ignored |
| | ESC * r B | Independent Station selection command dependent Only valid for thermal | Valid | | Invalid | Four bytes ignored | Invalid | Four bytes ignored |
| | ESC * r C | Independent Station selection command dependent Only valid for thermal | Valid | | Invalid | Four bytes ignored | Invalid | Four bytes ignored |

| Type | Command | Execution Station Thermal, Slip, Validation | Thermal | | Slip | | Validation | |
|------------------------|--------------------|---|--|-------------------|--------------------|--|---|--|
| | | | Line | Other Precautions | Line/Page | Other Precautions | Line/Page | Other Precautions |
| Raster Mode | ESC * r D | Independent Station selection command dependent Only valid for thermal | Valid | | Invalid | Data received and discarded up to <NUL>. | Invalid | Data received and discarded up to <NUL>. |
| | b | Independent Station selection command dependent Only valid for thermal | Valid | | Invalid | Data for the amount of the counter received and discarded | Invalid | Data for the amount of the counter received and discarded |
| | k | Independent Station selection command dependent Only valid for thermal | Valid | | Invalid | Data for the amount of the counter received and discarded | Invalid | Data for the amount of the counter received and discarded |
| | ESC * r Y | Independent Station selection command dependent Only valid for thermal | Valid | | Invalid | Data received and discarded up to <NUL>. | Invalid | Data received and discarded up to <NUL>. |
| | ESC FF NUL | Independent Station selection command dependent Only valid for thermal | Valid | | Invalid | Three bytes ignored | Invalid | Three bytes ignored |
| | ESC FF EOT | Independent Station selection command dependent Only valid for thermal | Valid | | Invalid | Three bytes ignored | Invalid | Three bytes ignored |
| | ESC * r N | Independent Station selection command dependent Only valid for thermal | Valid | | Invalid | Data for the amount of the counter received and discarded | Invalid | Data for the amount of the counter received and discarded |
| | ESC * r V | Independent Station selection command dependent Only valid for thermal | Valid | | Invalid | Data received and discarded up to <NUL>. | Invalid | Data received and discarded up to <NUL>. |
| | Mark Com- mands | ESC GS * 0 | Independent Station selection command dependent | Valid | | Invalid | All data for the counter received and discarded | Invalid |
| ESC GS * W | | Shared | Valid | Valid | Shared | | Valid | |
| ESC GS * C | | Shared | Valid | Shared | Valid | | Shared | |
| Auto Logo | ESC GS / W | Shared | Valid | Shared | Valid | | Shared | |
| | ESC GS / C | Shared | Valid | Shared | Valid | | Shared | |
| User ID | ESC GS % W | Shared | Valid | Shared | Valid | | Shared | |
| | ESC GS % 1 | Shared | Valid | Shared | Valid | | Shared | |
| | ESC GS % P | Independent Station selection command dependent | Valid | Shared | Invalid | Five bytes ignored | Shared | Invalid |
| PDF 417 | ESC GS x P | Independent Station selection command dependent | Valid | | Invalid | Four bytes ignored | Invalid | Four bytes ignored |
| | ESC GS x I | Shared | Valid | Valid | Shared | Sends "Error" | Valid | Shared |
| Maintenance Counter | ESC GS M | Independent Station selection command dependent | Valid | | Valid only Line | Page Mode: Six bytes ignored | Valid only Line | Page Mode: Six bytes ignored |
| Program Overwrite | ESC GS ? | Shared | Valid | Valid | Shared | | Valid | Shared |
| Printer Driver | ESC GS CAN | Shared | Valid | Valid | Shared | | Valid | Shared |
| Print Start Trigger | ESC GS g 0 | Independent Station selection command dependent | Valid | | Invalid | Six bytes ignored | Invalid | Six bytes ignored |
| QR Codes | ESC GS y P | Independent Station selection command dependent | Valid | | Invalid | Four bytes ignored | Invalid | Four bytes ignored |
| | ESC GS y I | Shared | Valid | Valid | Shared | Sends "Error" | Valid | Shared |

| Type | Command | Execution Station Thermal, Slip, Validation | Thermal | | Slip | | Validation | |
|------------------------|----------------|---|---------|---------------------|-----------------|-------------------------------|-----------------|------------------------------|
| | | | Line | Other Precautions | Line/Page | Other Precautions | Line/Page | Other Precautions |
| Head Failure Detection | ESC RS # | Independent Station selection command dependent | Invalid | Four bytes ignored | Invalid | Four bytes ignored | Invalid | Four bytes ignored |
| Slip Function | ESC FF | Independent Station selection command dependent | Invalid | Three bytes ignored | Valid Shared | | Valid Shared | |
| Page Mode | FF (Page Mode) | Independent Station selection command dependent | Ignored | One byte ignored | Valid Page only | Line Mode: One byte ignored | Valid Page only | Line Mode: One byte ignored |
| Station Switch | ESC + A | Independent Station selection command dependent | Valid | | Valid only Line | Page Mode: Six bytes ignored | Valid only Line | Page Mode: Six bytes ignored |
| Presenter | ESC SYN 0 | Shared | Invalid | Four bytes ignored | Invalid | Four bytes ignored | Invalid | Four bytes ignored |
| | ESC SYN 3 | Shared | Invalid | Four bytes ignored | Invalid | Four bytes ignored | Invalid | Four bytes ignored |
| | ESC SYN 4 | Shared | Invalid | Four bytes ignored | Invalid | Four bytes ignored | Invalid | Four bytes ignored |
| MICR | ESC FS M | Independent Station selection command dependent | Invalid | Five bytes ignored | Valid | Page Mode: Five bytes ignored | Invalid | Five bytes ignored |



**ELECTRONIC PRODUCTS DIVISION
STAR MICRONICS CO., LTD.**

536 Nanatsushinya, Shimizu-ku, Shizuoka,
424-0066 Japan
Tel: (int+81)-54-347-0112, Fax: (int+81)-54-347-0709

Please access the following URL
<http://www.star-m.jp/eng/dl/dl02.htm>
for the latest revision of the manual.

**OVERSEAS SUBSIDIARY COMPANIES
STAR MICRONICS AMERICA, INC.**

1150 King Georges Post Road, Edison, NJ 08837-3729 U.S.A.
Tel: (int+1)-732-623-5555, Fax: (int+1)-732-623-5590

STAR MICRONICS EUROPE LTD.

Star House, Peregrine Business Park, Gomm Road,
High Wycombe, Bucks, HP13 7DL, U.K.
Tel: (int+44)-1494-471111, Fax: (int+44)-1494-473333

STAR MICRONICS ASIA LTD.

Rm. 1901-5, 19/F., Enterprise Square Two,
3 Sheung Yuet Road, Kowloon Bay, Hong Kong
Tel: (int+852)-2796-2727, Fax: (int+852)-2799-9344

Free Manuals Download Website

<http://myh66.com>

<http://usermanuals.us>

<http://www.somanuals.com>

<http://www.4manuals.cc>

<http://www.manual-lib.com>

<http://www.404manual.com>

<http://www.luxmanual.com>

<http://aubethermostatmanual.com>

Golf course search by state

<http://golfingnear.com>

Email search by domain

<http://emailbydomain.com>

Auto manuals search

<http://auto.somanuals.com>

TV manuals search

<http://tv.somanuals.com>