



DOT MATRIX PRINTER MECHANISM
MP111MP-24G-A
MP115MP-24G-A
SPECIFICATION
AND
OPERATION MANUAL



stair 

NOTICE

- All rights reserved. Reproduction of any part of this manual in any form whatsoever, without STAR's express permission is forbidden.
- The contents of this manual are subject to change without notice.
- All efforts have been made to ensure the accuracy of the contents of this manual at the time of going to press. However, should any errors be detected, STAR would greatly appreciate being informed of them.
- The above notwithstanding, STAR can assume no responsibility for any errors in this manual.

©Copyright 1999 Star Micronics Co., LTD.

Contents

1. GENERAL DESCRIPTION	1
2. CONSTRUCTION	2
2.1 Configuration	2
2.2 Principle of Operation	2
3. GENERAL SPECIFICATIONS	5
3.1 Printing Specifications	5
3.2 Paper Specifications	6
3.3 Ink Ribbon Specifications	7
3.4 Connector Specifications	9
3.5 Print Timing	11
3.6 Timing Chart	12
3.7 Print Head Specifications	14
3.8 CR Motor Specifications	18
3.9 Paper Feed Motor Specifications	20
3.10 Ribbon Shift Solenoid (RS-SOL) Specifications	21
3.11 Timing Signal Detector Specifications	22
3.12 Home Position Detector (HP-sig) Specifications	23
3.13 Paper-out Detector (PE-sig) Specifications	23
3.14 Ribbon Position Detector (RS-sig) Specifications (MP115MP only)	24
3.15 Dimension and Weight	24
4. RELIABILITY SPECIFICATIONS	27
5. SETTING THE RIBBON CARTRIDGE	28
6. SETTING THE PAPER	29
6.1 Setting the Paper	29
6.2 Removing the Paper	29
7. INSTALLATION	30
8. OPERATIONAL NOTES	35
8.1 Power ON/OFF Note	35
8.2 Carriage Motor Protection Method (Against Mechanical Errors)	36
8.3 Other Notes	36
9. POWER SUPPLY CAPACITY	37
9.1 24 V Line	37
9.2 5 V Line	37
10. OPTIONS	38

1. GENERAL DESCRIPTION

MP111MP-24G-A and MP115MP-24G-A are serial impact dot matrix printer mechanisms used to record data and as electrical equipment such as for ECR.

Model Name Notation

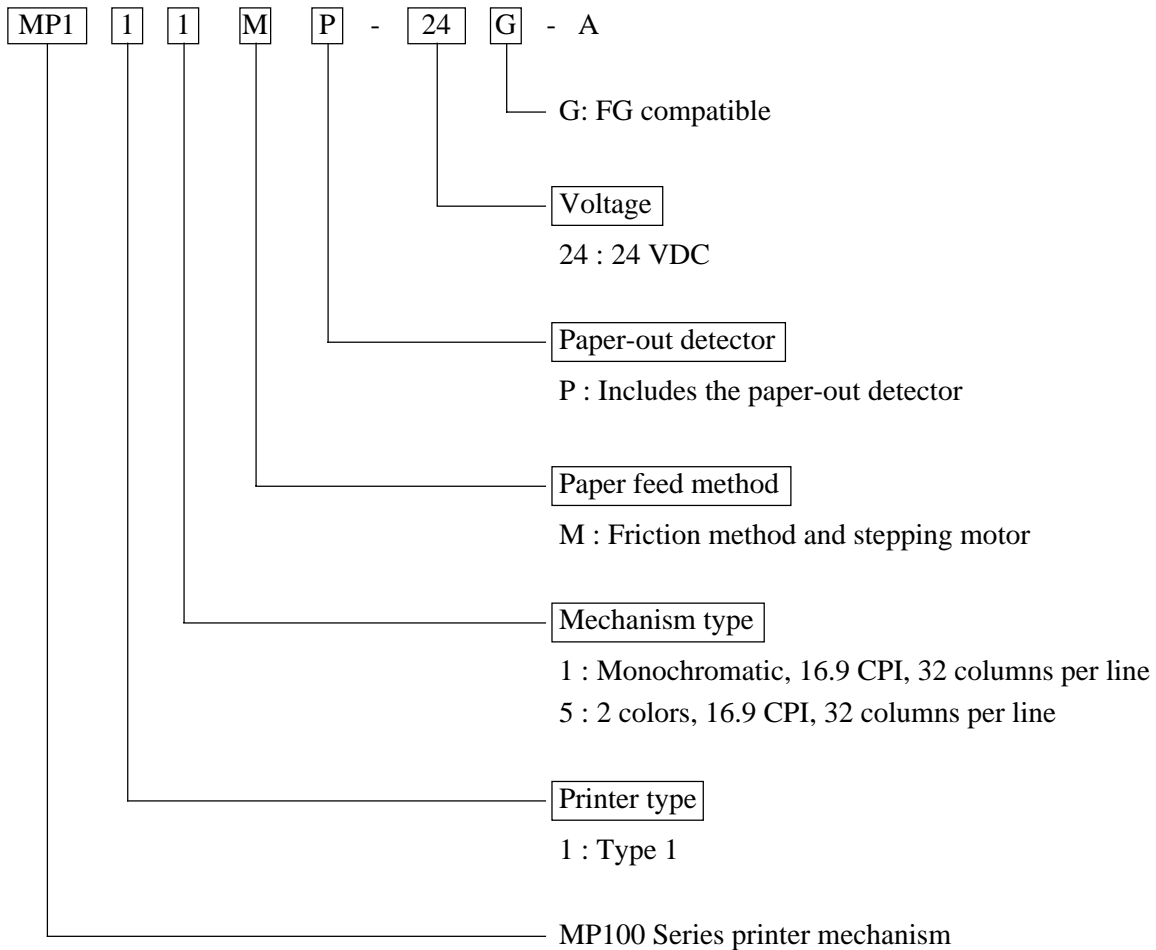

2. CONSTRUCTION

2.1 Configuration

This printer mechanism is composed of the following components.

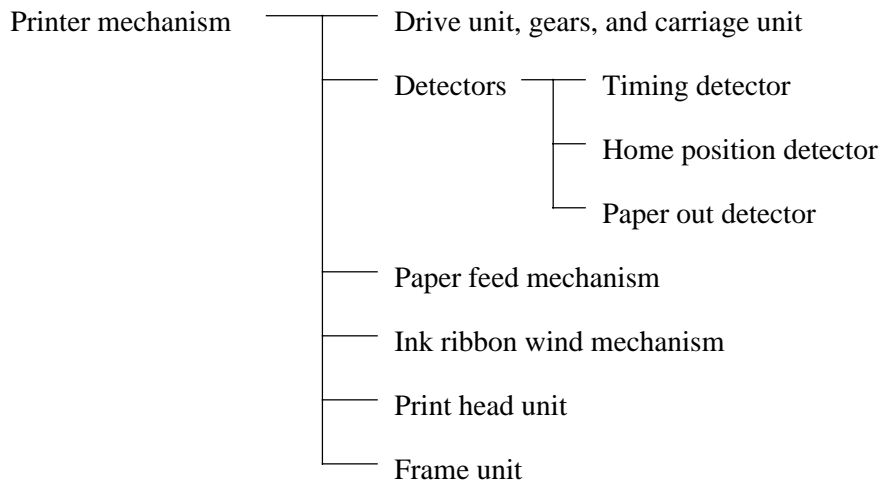

Other

You can also use 1.75 inch (45 mm) width roll paper by removing the paper guide B and attaching the optional guide.

2.2 Principle of Operation

2.2.1 Drive

This printer mechanism moves the print head, feeds paper and feed ribbon with the motor.

2.2.2 Print head movement

The rotation of the motor is transmitted to drive shaft through the reduction gears. The carriage makes lateral reciprocal movements along a groove that is carved on this drive shaft, consequently moving the print head.

2.2.3 Print timing

Printing is done when the timing signal is generated synchronized with the rotation of the motor, based on the home position signal.

2.2.4 Ribbon feed

The ink ribbon is housed inside a ribbon cartridge in endless fashion. A ribbon feed roller is turned by the rotation of the motor whereby the ink ribbon is wound up.

2.2.5 Paper feed

Paper feeding is done by the rotation of the stepping motor.

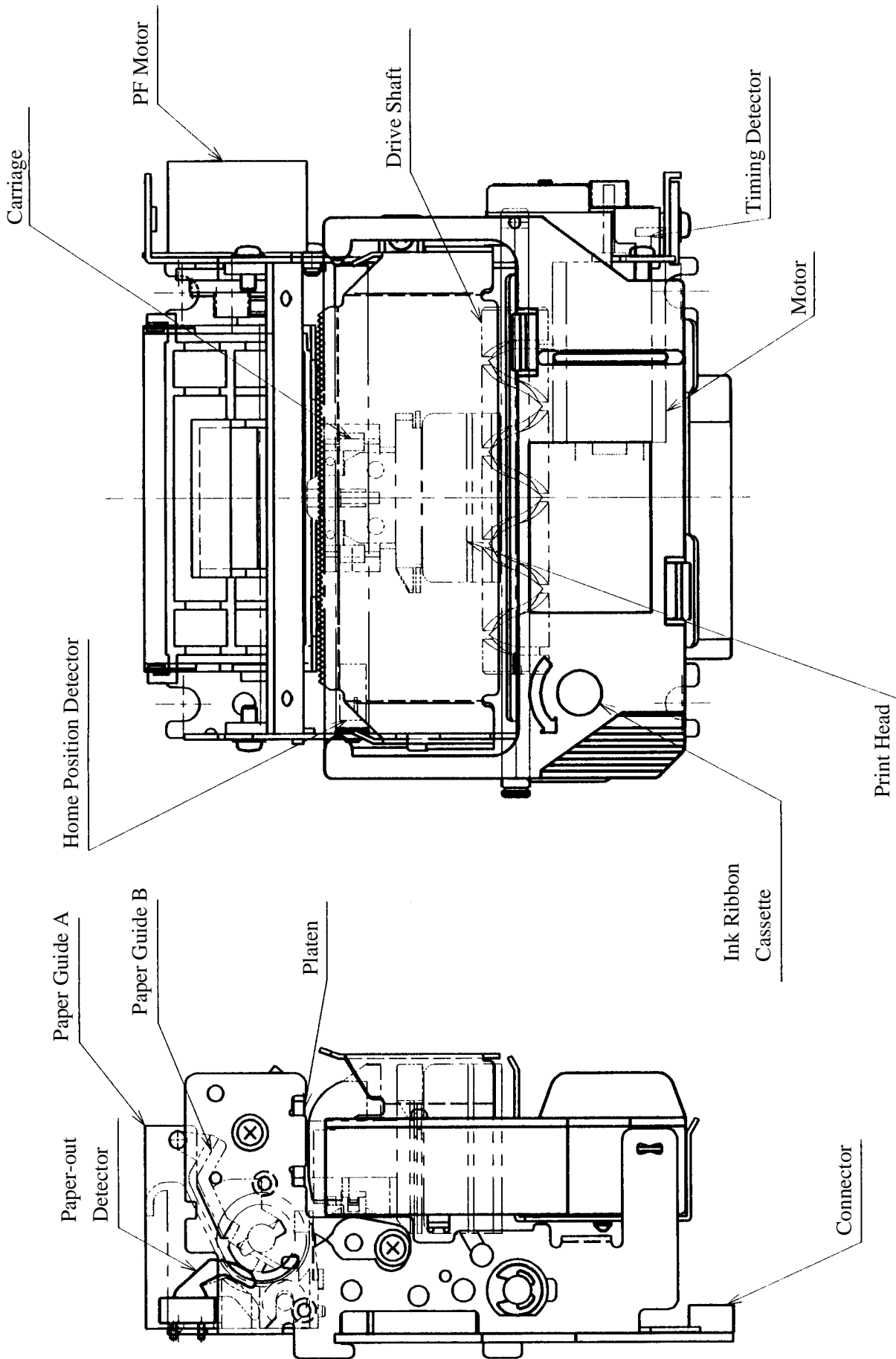

Fig. 2-1 MP111MP External view

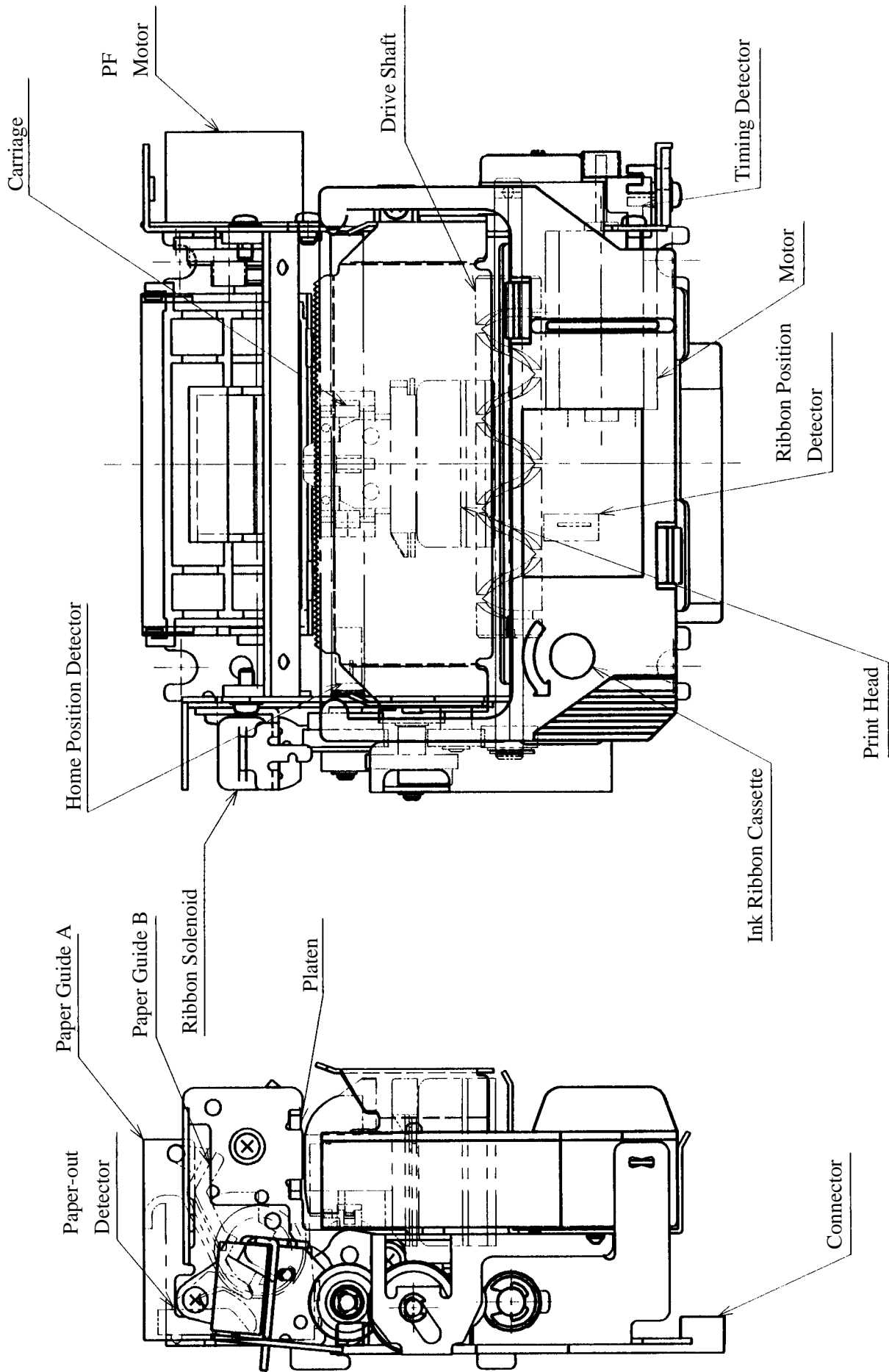

Fig. 2-2 MP115MP External view

3. GENERAL SPECIFICATIONS

3.1 Printing Specifications

Item	Specifications
Printing method	Impact Dot Matrix
Printing configuration	7 x 9 (half dot) or 5 x 9
Printing direction	Bidirectional (See note 1)
Printing speed	Approximately 3.85 lines/second
Printing lines	32 lines (when using 7 x 9 half dots)
Character dimension	Width 1.2 mm (when using 7 x 9 half dots) Height 2.42 mm
Dot spacing	Horizontal 0.3 mm (with full dots) Vertical 0.353 mm
Printing area	48 mm
Paper feed speed	Approximately 3.77 in./sec. (continuous feeding)
Wire diameter	ø 0.3 mm
Line space	1/6, 1/8, 1/12, 1/72, 1/144 inches Feed paper more than one line before printing graphics or vertically expanded characters.

Note 1: When performing bidirectional printing, horizontal drift is likely to occur in unidirectional printing.

Details of Character Dimentions

1	Paper width	2.25 inches (57.5 mm)	1.75 inches (44.5 mm) Optional
2	Fonts configuration (H x V)	7 x 9 (half)	5 x 9 (half)
3	CPI	16.9	14.1
4	Printing column count	32	26
5	Spacing e mm	1.5	1.8
6	Character dimensions c mm	1.2	1.5
	d mm	2.42	2.42
7	Dot space a mm	0.3	0.3
	b mm	0.353	0.353
8	Total no. of dots	160	156
9	Printing area mm	48	46.8

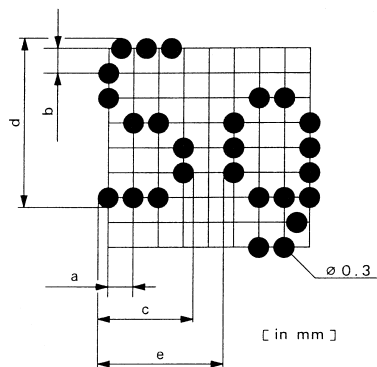

Fig. 3-1 Character Size (7x 9 font)

3.2 Paper Specifications

Item	Specifications
Paper type	Ordinary roll paper (1P) and carbonless roll paper (2P or 3P)
Paper width	57.5 ± 0.5 mm (2.25 inch). With options, 44.5 ± 0.5 mm (1.75 inch) possible
Roll diameter	Max. 85 mm (3.35 inch)
Thickness	Single : 0.07 mm to 0.10 mm Copies : Original + 1 copy Total thickness max. 0.14 mm, with each sheet 0.05 to 0.08 mm thick Original + 2 copies Total thickness max. 0.2 mm, with each sheet 0.05 to 0.08 mm thick
Core diameter	12 ± 1 mm
Other	No glue between the paper and the core diameter

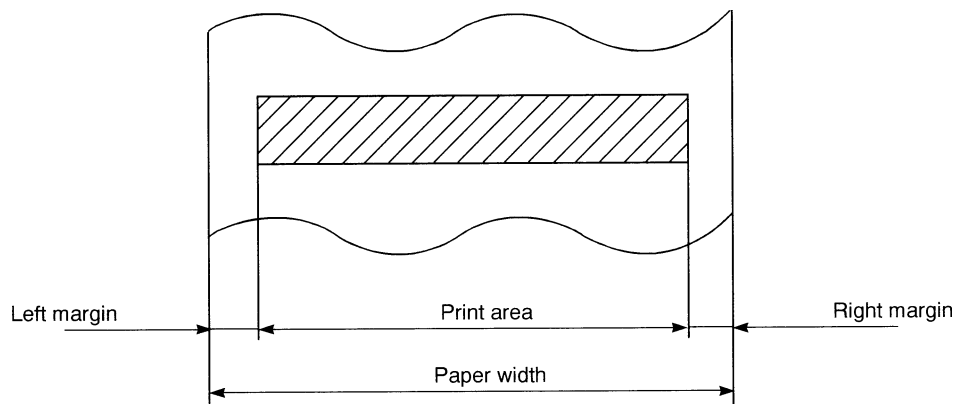

Fig. 3-2 Paper spec. & Print area

3.3 Ink Ribbon Specifications

1) MP111

Item	Specifications
Type	Dedicated cartridge
Color	Purple (standard)
Ribbon material	Nylon 66
Ribbon size	Width: 13 mm
Model name	Purple (standard): Ribbon cassette RC100 P Black (optional): Ribbon cassette RC100 B
Ribbon life	Purple: Approx. 1,500,000 characters Black: Approx. 800,000 characters

Note: There is the possibility of damaging the printer by using ribbon cassettes that have not been specified. We do not offer warranty for problems that occur from using the wrong ribbon cassette.

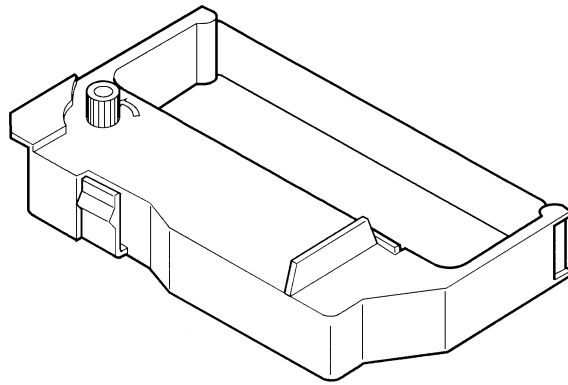

Fig. 3-3 Ink ribbon cartridge (RC100 P.B.)

2) MP115

Item	Specifications
Type	Dedicated cartridge
Color	Black and red
Ribbon material	Nylon 66, (#40 denier)
Ribbon size	Width: 13 mm
Model No.	Black and red: Ribbon cassette RC100BR
Ribbon life	Black: Approx. 400,000 characters Red: Approx. 250,000 characters

Note: There is the possibility of damaging the printer by using ribbon cassettes that have not been specified. We do not offer warranty for problems that occur from using the wrong ribbon cassette.

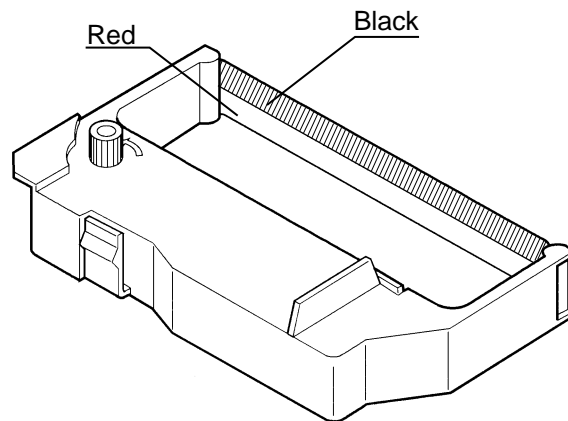

Fig. 3-4 Ink ribbon cartridge (RC100BR)

3.4 Connector Specifications

/	Connector Type NIPPON FCI HLEM28R-1
Connection Drawing	See next page

1	HD #6
2	HD CMN
3	HD #4
4	HD #5
5	HD #1
6	HD CMN
7	HD #2
8	HD #3
9	HD CMN
10	HD #7
11	HD #8
12	HD #9
13	LF- ϕ 4
14	LF-CMN A, B
15	LF- ϕ 2
16	LF- ϕ 1
17	LF- ϕ 3
18	RS-Sig (Ribbon shift) MP115M only
19	S-GND
20	PE-Sig
21	CR MOTOR (-)
22	HP-Sig
23	RS-SOL (Ribbon shift) MP115M only
24	T2-Sig
25	T1-Sig
26	+5V
27	NC
28	CR MOTOR (+) (CMN VH)

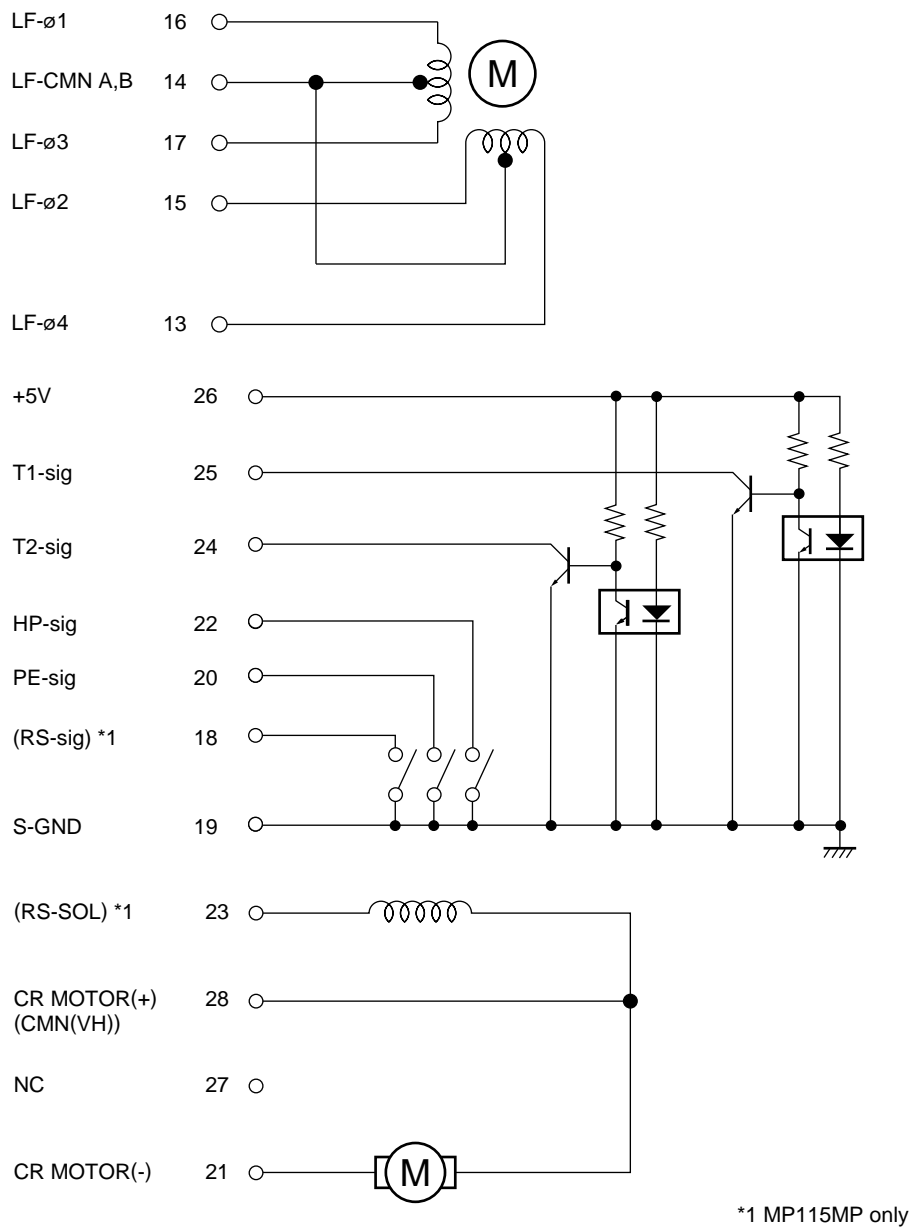

Fig. 3-5 Connector connections

3.5 Print Timing

This printer uses a timing signal of 1 as the total number of pulses to control the solenoid and motor. The numbering of T_n of the timing signal 1 is found as shown below. The first timing signal 2 after the rise of the home position signal is detected and the fall of the first timing signal 1 after the rise of timing signal 2 is set as $T-1$. The subsequent timing signal falls are set as T_0 , T_1 and T_2 .

You should be careful of the following points concerning this print timing.

There is a minimum of 2 pulses for the timing signal 1 for electrical cycles for the same pin. Therefore, you cannot energize T_n , T_{n+1} using the same pin.

7X9 (half) font

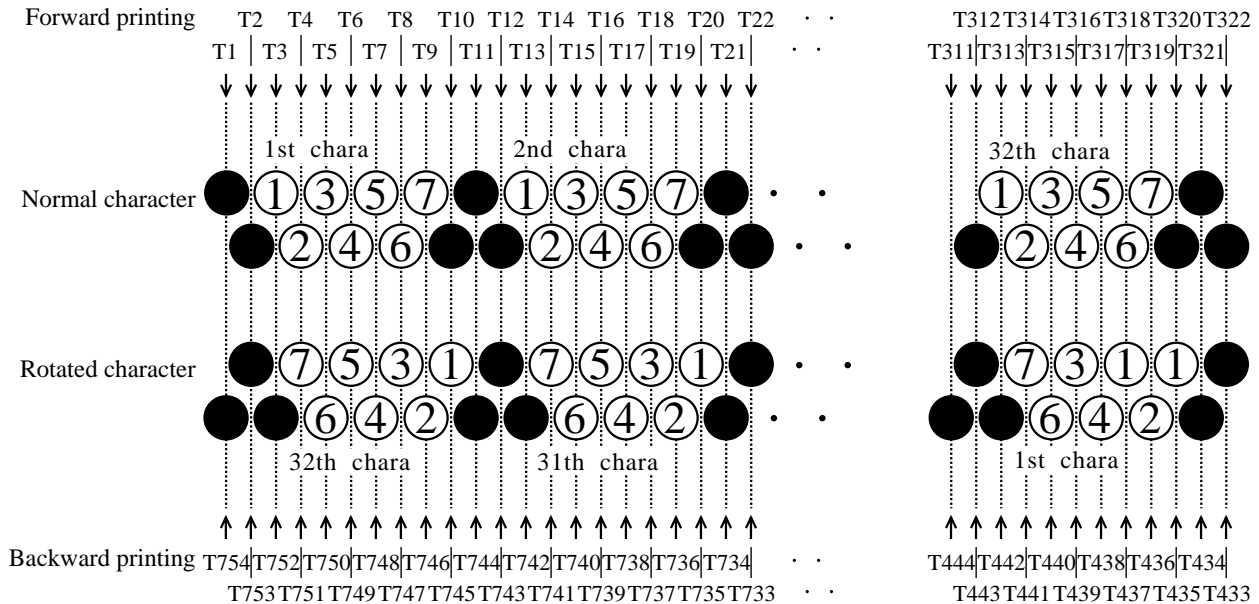

Note) The electric cycles for identical 1 pins has 2 pulses or more.
There T_n , T_{n+1} electricity is impossible

5X9 font

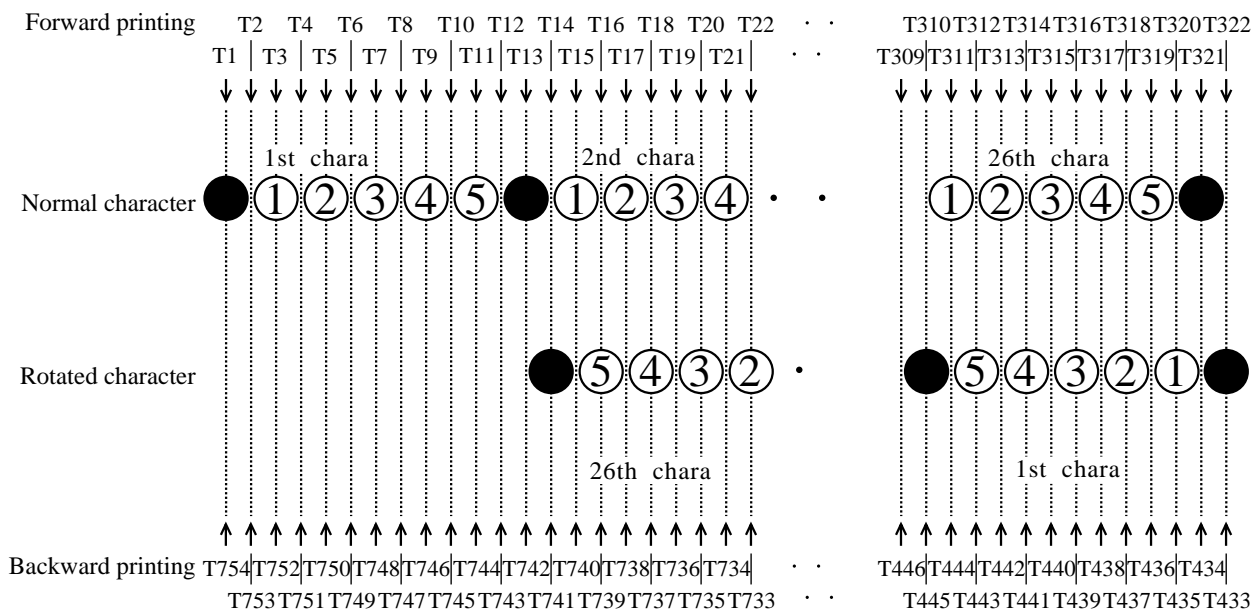
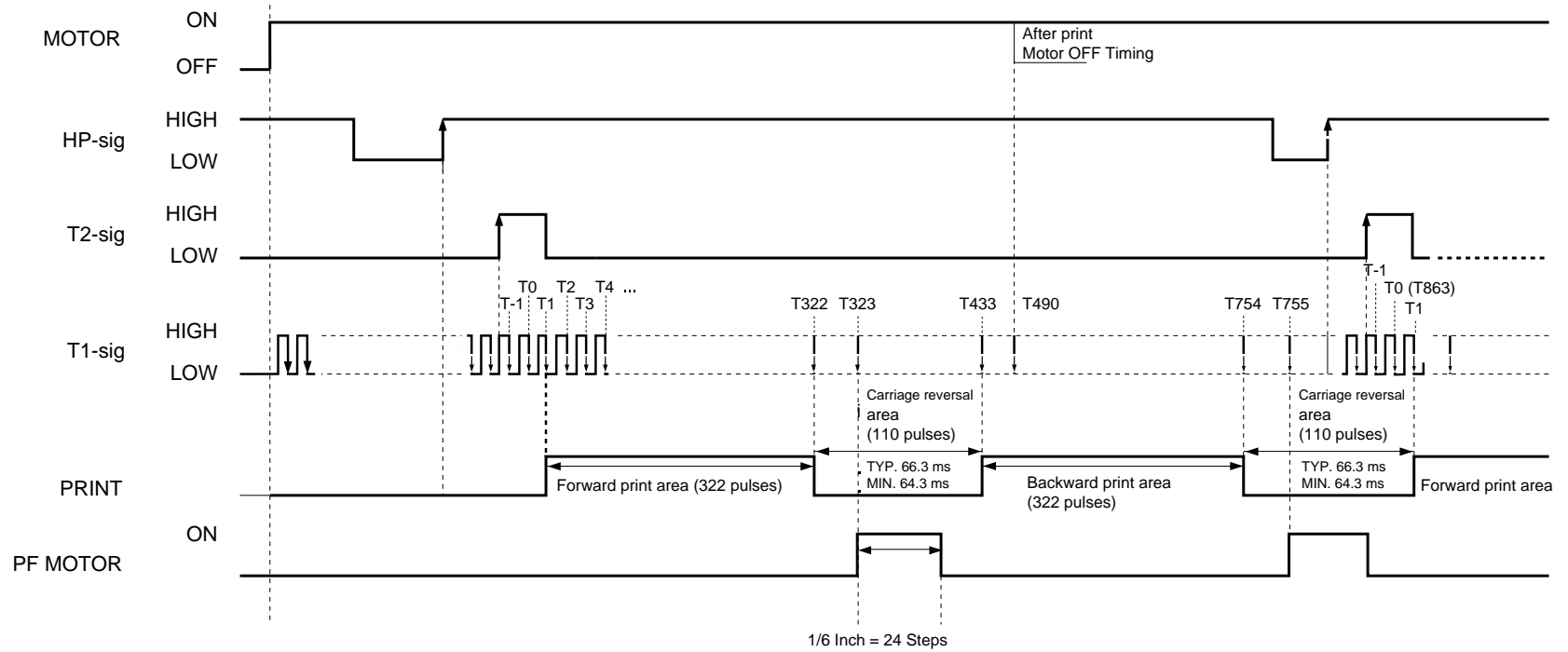

Fig. 3-6 Print Timing

3.6 Timing Chart

(1) Printing Action



T1-sig: Type 1660 Hz, Max. 1710 Hz (Software and CPU should be designed at Max. 2000 Hz.)
Printing speed: T1-sig 1600 Hz = Approximately 3.84 lines/sec. 1710 Hz = 3.96 lines/sec.
Paper feed action must be carried out within the carriage reversal area.

Fig. 3-7 Printing action

(2) Ribbon Shift Operation (Only with 2 color printing on the MP115)

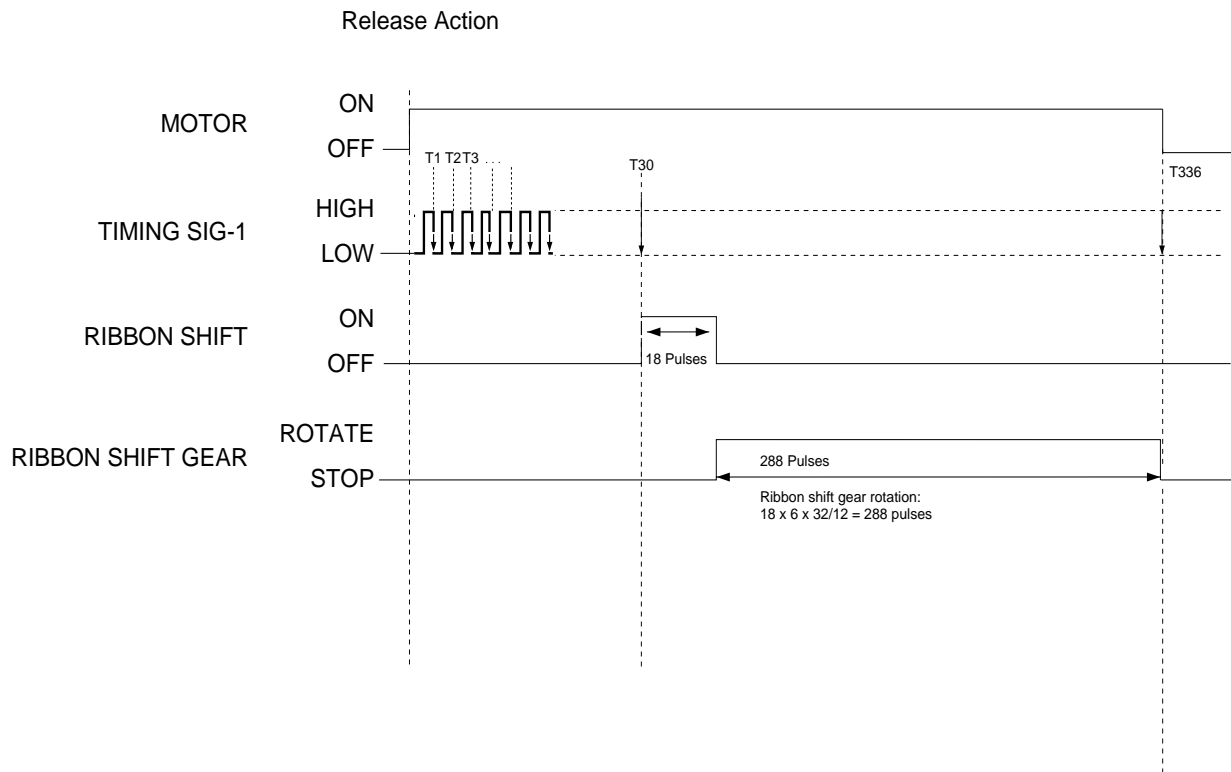

Fig. 3-8 Release action

3.7 Print Head Specifications

(1) Basic Specifications

Item	Specifications
Supply voltage	24 VDC \pm 2.4 V
Response frequency	Max. 900 Hz
Energized time	See below
Coil resistance	14.7 \pm 0.4 Ω (includes cable resistance)
Peak current	1.0 A/solenoid (for 24 VDC, 375 μ s)
Timing	Energizing is begun at the fall of the output signal of timing signal 1. Energizing cycle shall be 2 pulses or more of timing signal 1.

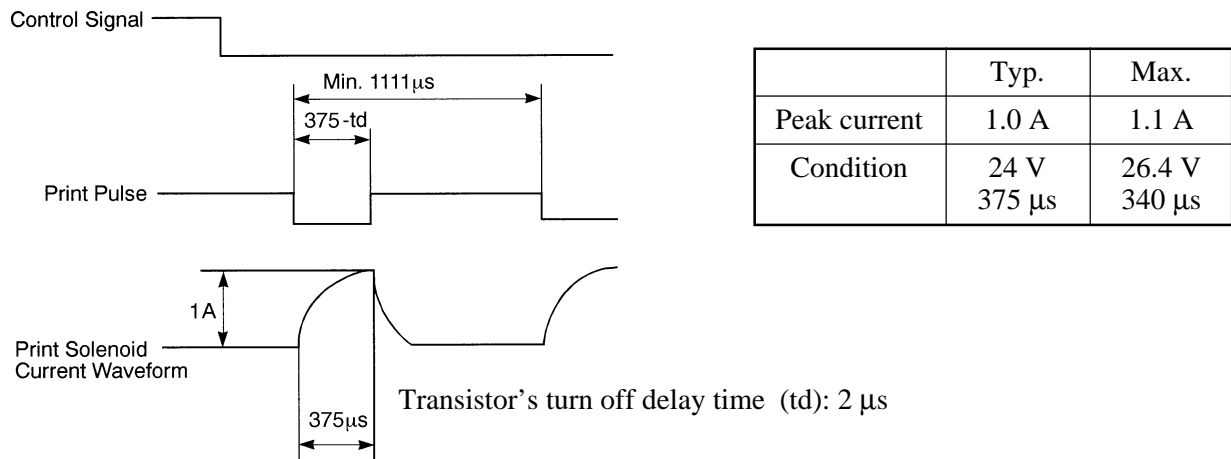

Fig. 3-9 Current waveform

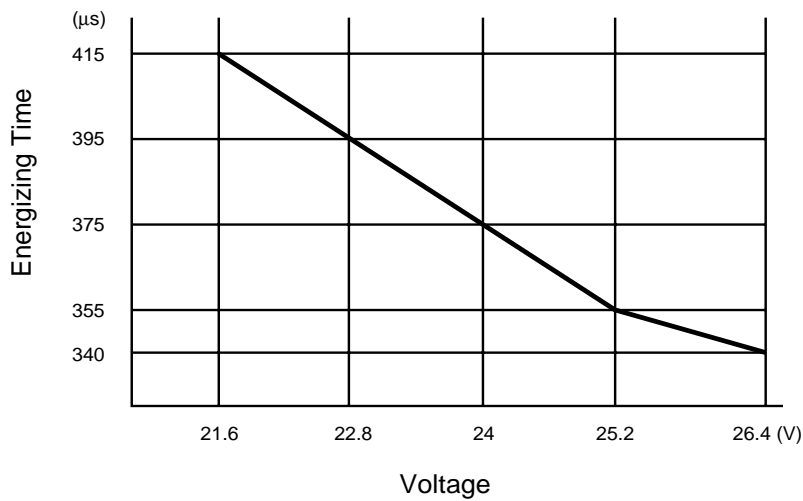

Fig. 3-10 Head Energizing Time - Head Power Supply Voltage

We employ a zener diode to control spike voltages that occur when the transistor is turned OFF. The following figure shows an example of the drive circuit. With this circuit, we use a transistor equipped with a zener diode (zener voltage 60 + 10/-5V) between the base and collector.

TR1	2SD2041 (ROHM)
R1	1K Ω
R2	330 Ω
VH	23V + TR1 for VCE (sat) = 24 V

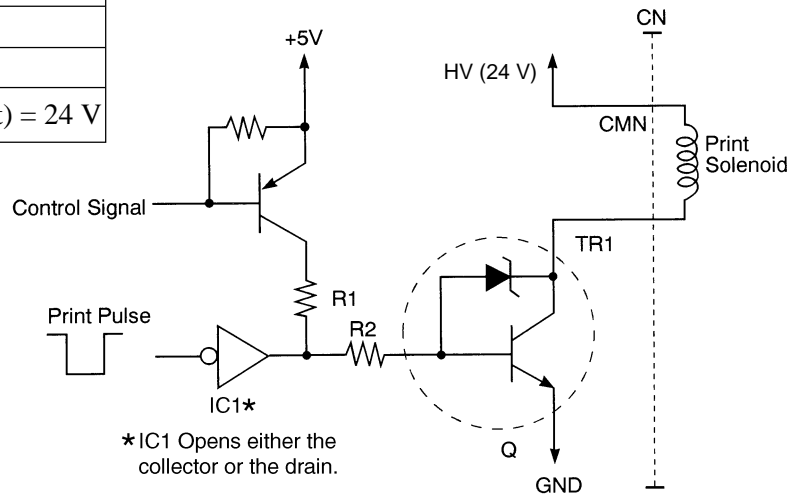

Fig. 3-11 Example of Print Solenoid Drive Circuit

(2) Pre-fire

This operation applies minute vibrations to the needle wire to allow for its smooth movement as printer warmup. Pre-fire is performed under the following conditions. The energizing time is too short to allow for the printing action to occur.

Operating time	When power is turned ON.	Number of times	32 Times
Frequency	900 Hz	Power supply voltage	DC24V ±2.4 V
Energizing time	175 ± 5 μs		

(3) Print Duty

This print head is not equipped with a head temperature detector. Therefore, use the printer within the maximum printing ratio shown below. If you print exceeding this printing ratio, you can damage the printer.

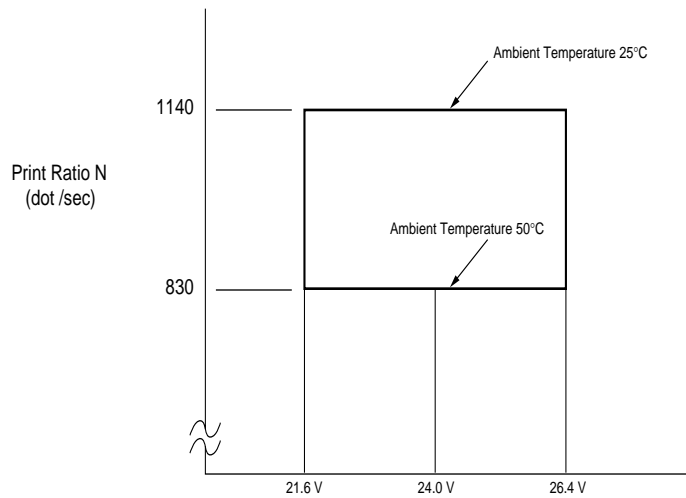

Fig. 3-12 Print duty

The figure above shows the print duty that is possible with continuous printing when each wire is used an equivalent number of times. In this case, you can calculate the possible dot count for D per character using the following numerical formula.

$$\frac{N \text{ (Print Ratio)} \times T \text{ (Print time per line includes the time of the paper feed [sec])}}{L \text{ (number of character per line)}} \quad \text{[dot/chara]}$$

When you use the specific wires many times, make sure the maximum print ratio is not over the print duty shown in Fig. 3-13. Fig. 3-13 shows operation at 24.0V.

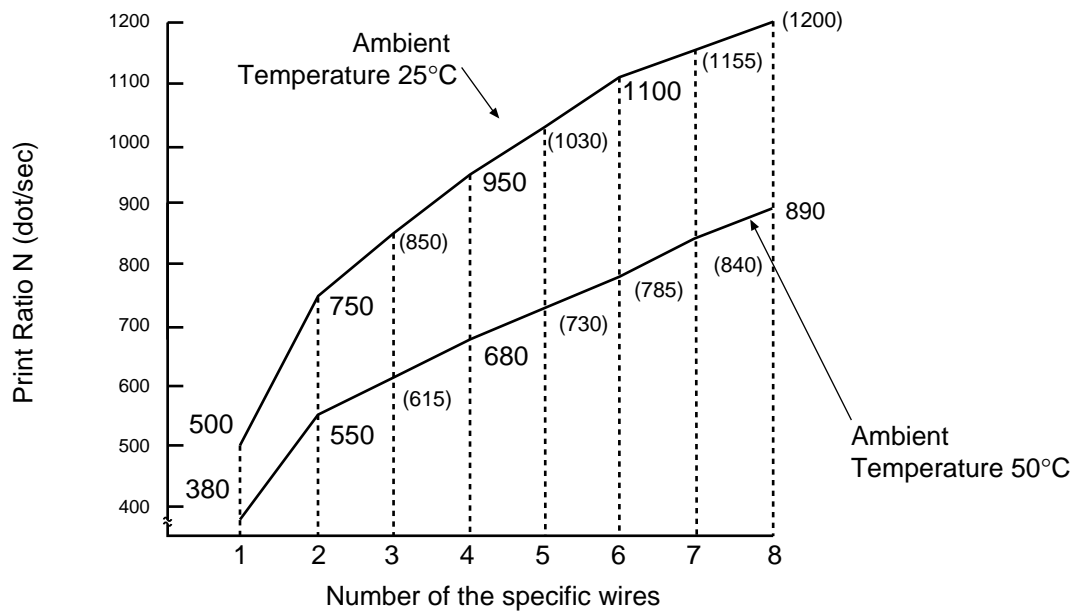

Fig. 3-13 Print duty (specific wires)

3.8 CR Motor Specifications

Item	Specifications
Type	DC motor
Supply voltage	24 VDC + 1.2 V
Start current	Max. 1.6 A
Average current	Approx. 0.15 A

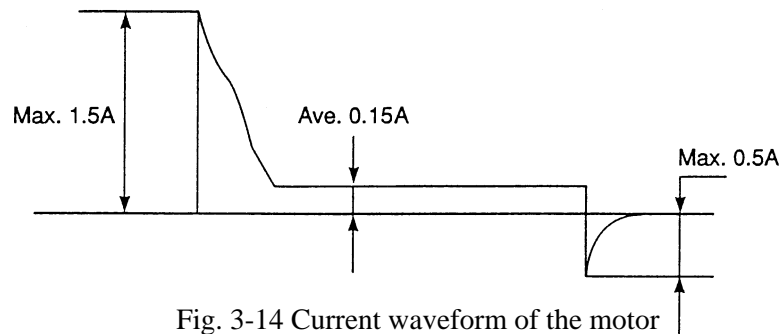

Fig. 3-14 Current waveform of the motor

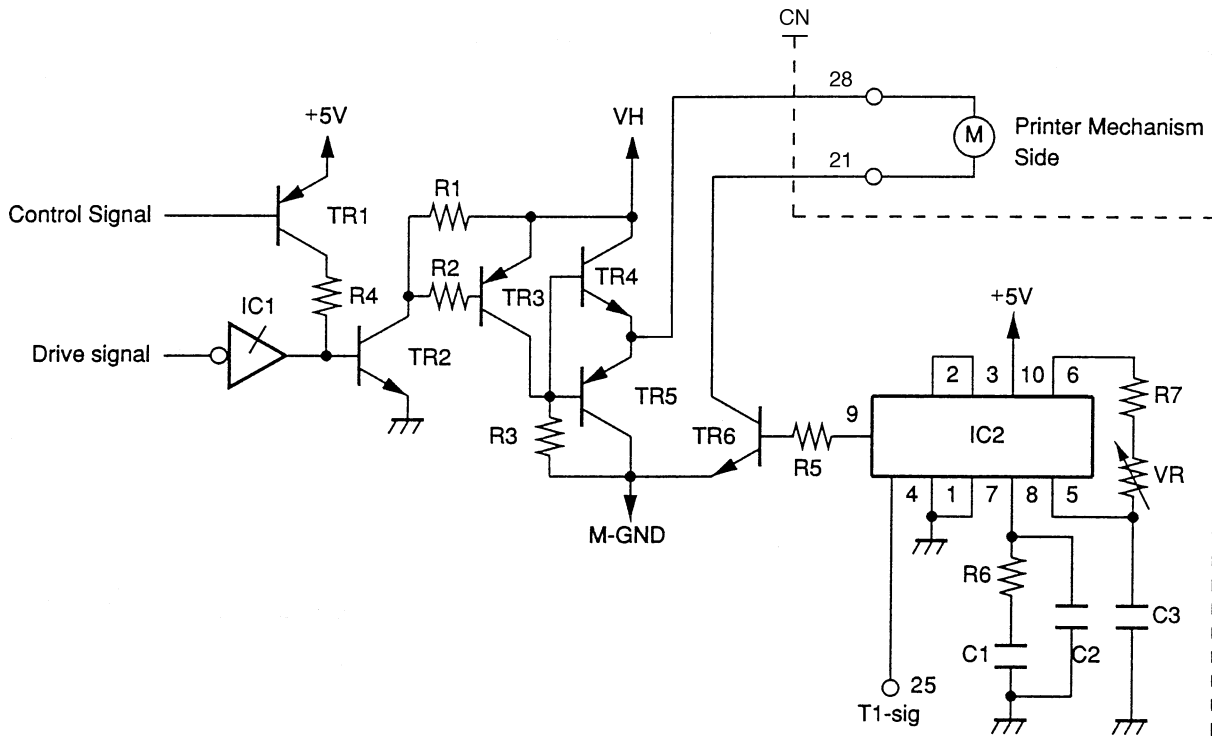

Fig. 3-15 Motor drive circuit (example)

R1	10 K Ω	TR1	2SA950
R2	3.3 K Ω	TR2	2SC1740
R3	6.8 K Ω 1/6 W	TR3	2SA1175
R4	2.2 K Ω	TR4	2SD882
R5	1.2 K Ω	TR5	2SB1359
R6	10 K Ω	TR6	2SD1637
R7	20 K Ω	IC1	SN74LS05
C1	0.47 μ F (Film)	IC2	M51971L (MITSUBISHI)
C2	0.033 μ F (Film)	VR	6.8 K Ω
C3	0.022 μ F (Film)		

Notes: Adjust motor speed with VR adjustment and T1 signal to 1660 Hz \pm 30 Hz.

3.8.1 FG Circuit

The motor control circuit with a Frequency Governor circuit maintains the printing speed at the settings. It is mainly constructed of a Speed Control IC (IC2) and a Power Transistor TR6 shown in Fig. 3-15. It measures the number of rotations of the Carriage Motor from the Timing Signal 1. This signal is then compared to the standard signal to control the speed by controlling the voltage energizing the Carriage Motor.

3.8.2 Merits of the FG Circuit

The FG circuit maintains a stable output regardless of the environment where it is being used.

It maintains stability even at high speeds.

It protects the head because the speed is stable.

3.9 Paper Feed Motor Specifications

Item	Specifications
Type	PM type stepping motor
Drive method	2-Phase excitation unipolar method
Terminal voltage	24 VDC \pm 1.2 V (for drive), 4.2 VDC (when holding)
Peak current	Max. 0.7 A
Average current	About 0.28 A
Holding current	About 0.08 A
Amount of paper feed	1/144 inch per 1 step
Feed method	Forward feed only
Excitation signal	a. When paper feed amount is less that 4 steps. Set to 350 pps drive. b. When paper feed amount is over 5 steps and less than 8 steps. Set the slow-down area so that the final 2 steps become 300 pps and 200 pps. The other areas are set to 350 pps drive. c. When paper feed amount is over 9 steps and less than 18 steps. Set the initial 4 steps so that they become 350 pps (slow-up area). Set the slow-down area so that the final 4 steps become 500 pps, 400 pps, 300 pps, and 200 pps. The other areas are set to 550 pps drive. d. When paper feed amount is over 19 steps. Set the initial and final 4 steps so that they become 350 pps. The other areas are set to 550 pps drive.

VH	24 V	D1	DSM1D1 (HITACHI)
TA1	μ PA1428AH (NEC)	R2 to R3	10 k Ω
TR1	2SB1359 Compatible	D1	DSM1D1 (Hitachi)
TR2	2SC1740 Compatible	IC	SN74L04

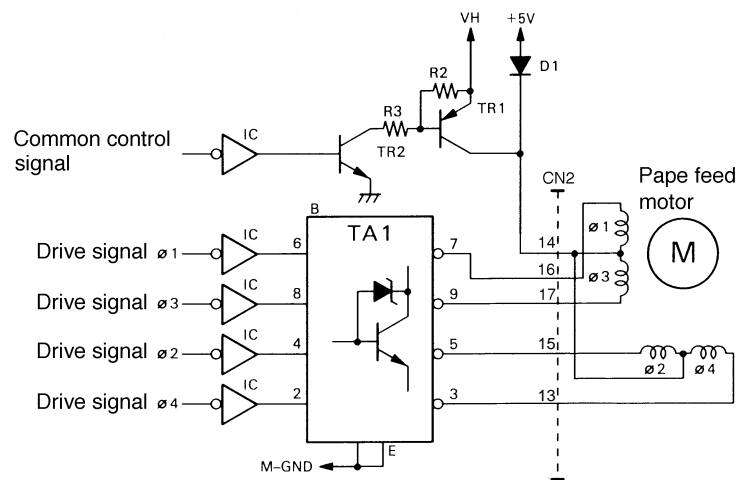

Fig. 3-16 Drive circuit of paper feed motor (example)

3.10 Ribbon Shift Solenoid (RS-SOL) Specifications

MP115MP only

Item	Specifications
Supply voltage	24 VDC \pm 1.2 V
Pulse width	T1-sig 18 pulses (Approx. 12 ms)
Coil resistance	Approx. 57.0 Ω
Average current	Approx. 400 mA

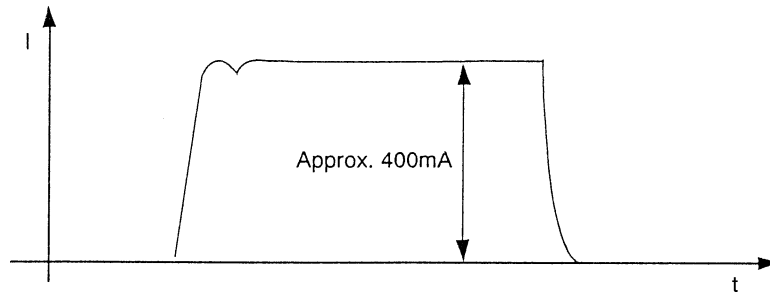

Fig. 3-17 Current waveform of RS-SOL

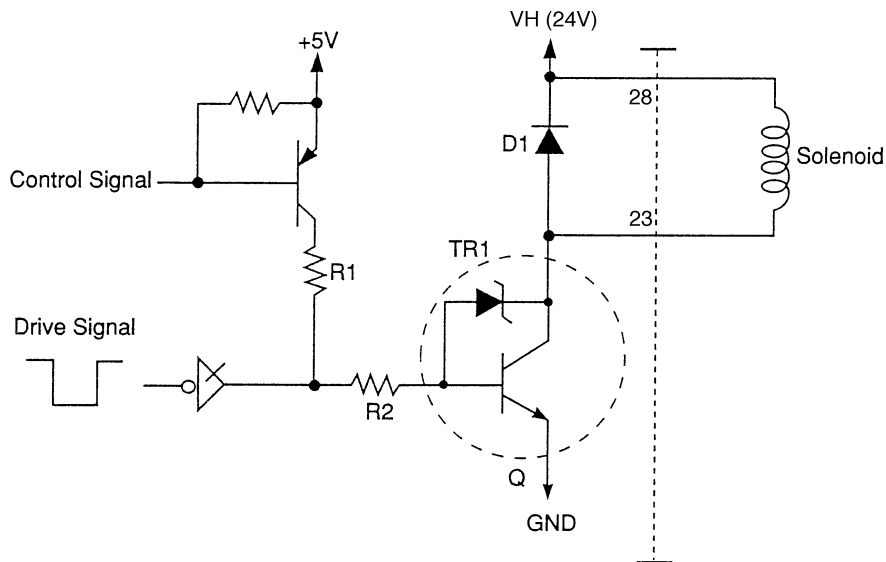

Fig. 3-18 RS-SOL drive circuit (example)

TR1	2SD2010 (ROHM)
D1	DSM1D1
R1	1 k Ω
R2	330 Ω
VH	23 V + TR1 VCE (sat.) = 24 V

3.11 Timing Signal Detector Specifications

The timing signal detector is composed of a detection slit mounted on the motor shaft, a photo interruptor, and waveform shaping circuit.

Timing signal 1 is generated 18 pulses and timing signal 2 is generated 1 pulse every time the motor rotates by 1 turn.

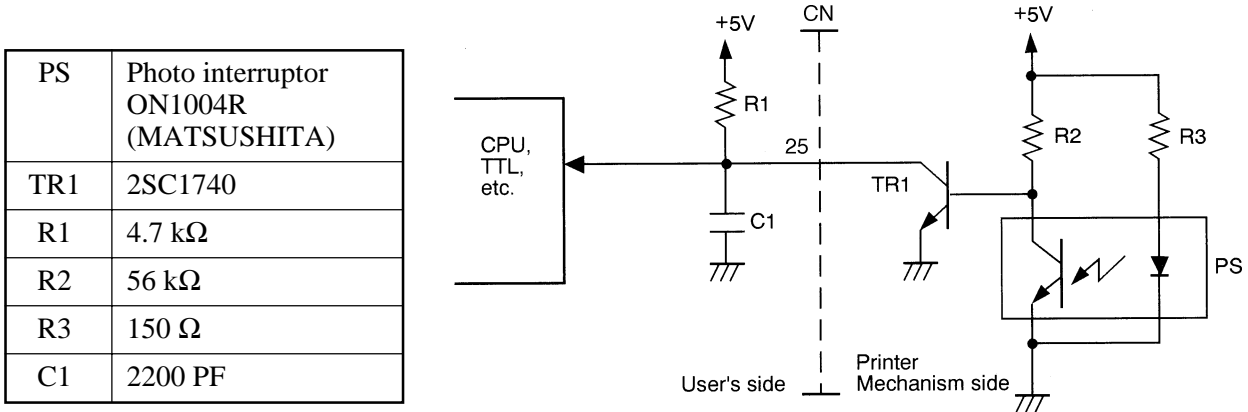

Fig. 3-19 Circuit of timing signal 1 (example)

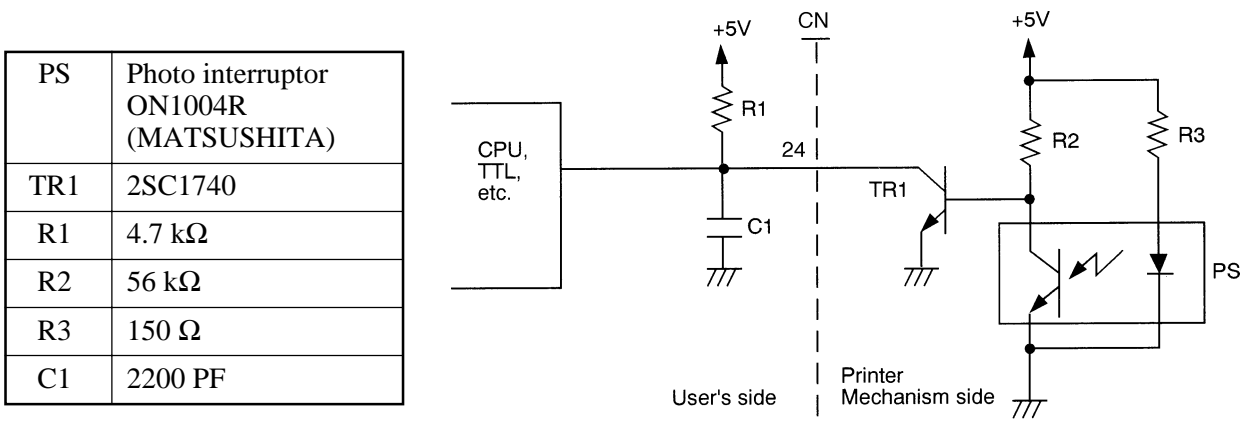

Fig. 3-20 Circuit of timing signal 2 (example)

3.12 Home Position Detector (HP-sig) Specifications

The home position detector is composed of the mechanical switch. While the carriage is located at the left end, the switch remains ON.

R1	10 k Ω
R2	15 k Ω
C1	0.022 μ F

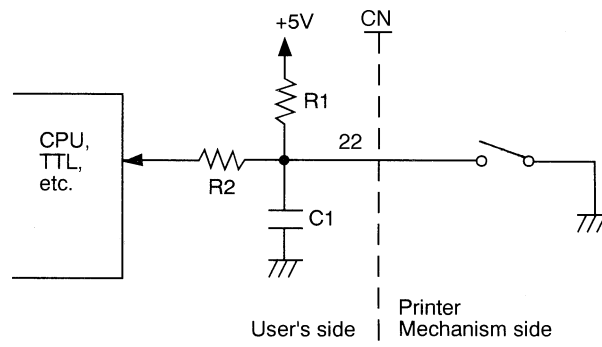

Fig. 3-21 Home position detector circuit (example)

In order to improve reliability, we recommend that the HP-sig is detected as described below.

- (1) When the T1-sig is unstable when turning on the power, etc.

Detect the L level after having detected the H level of the HP-sig, and then, after having carried out 81 pulse counts for the T1-sig, detect the H level.

- (2) When the T1-sig is decided during continuous operation of the motor

Detect the L level of the HP-sig, and then, after having counted 847 pulses of the T1-sig, detect the H level.

3.13 Paper-out Detector (PE-sig) Specifications

The Paper-out Detector is composed of a mechanical switch. While the paper is set in the paper tray, the switch remains ON.

R1	10 k Ω
R2	15 k Ω
C1	0.022 μ F

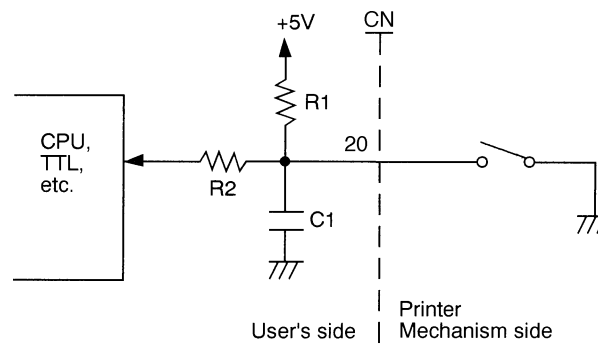

Fig. 3-22 Paper-out detector circuit (example)

3.14 Ribbon Position Detector (RS-sig) Specifications (MP115MP only)

The ribbon position is made up by a mechanical switch.

When the ribbon is at the position for printing of black characters, the switch is ON.

R1	10 k Ω
R2	15 k Ω
C1	0.022 μ F

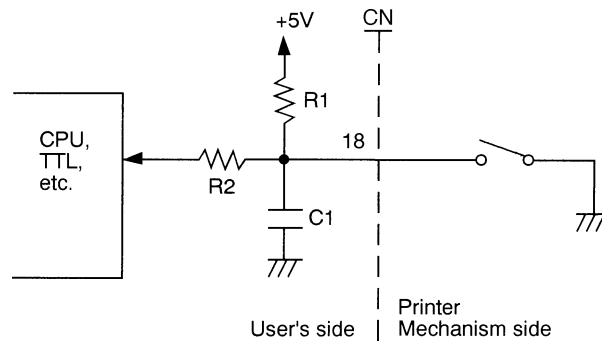

Fig. 3-23 Example of ribbon position detection circuit

In order to improve the reliability, we recommend that the RS-sig is detected while the motor is off.

3.15 Dimension and Weight

See Fig on the next page for external dimension of the printer mechanism.

Weight of printer mechanism: MP111MP, approx. 410 g (excludes the ribbon cartridge)

MP115MP, approx. 450 g (excludes the ribbon cartridge)

Weight of ink ribbon cartridge: approx. 24 g

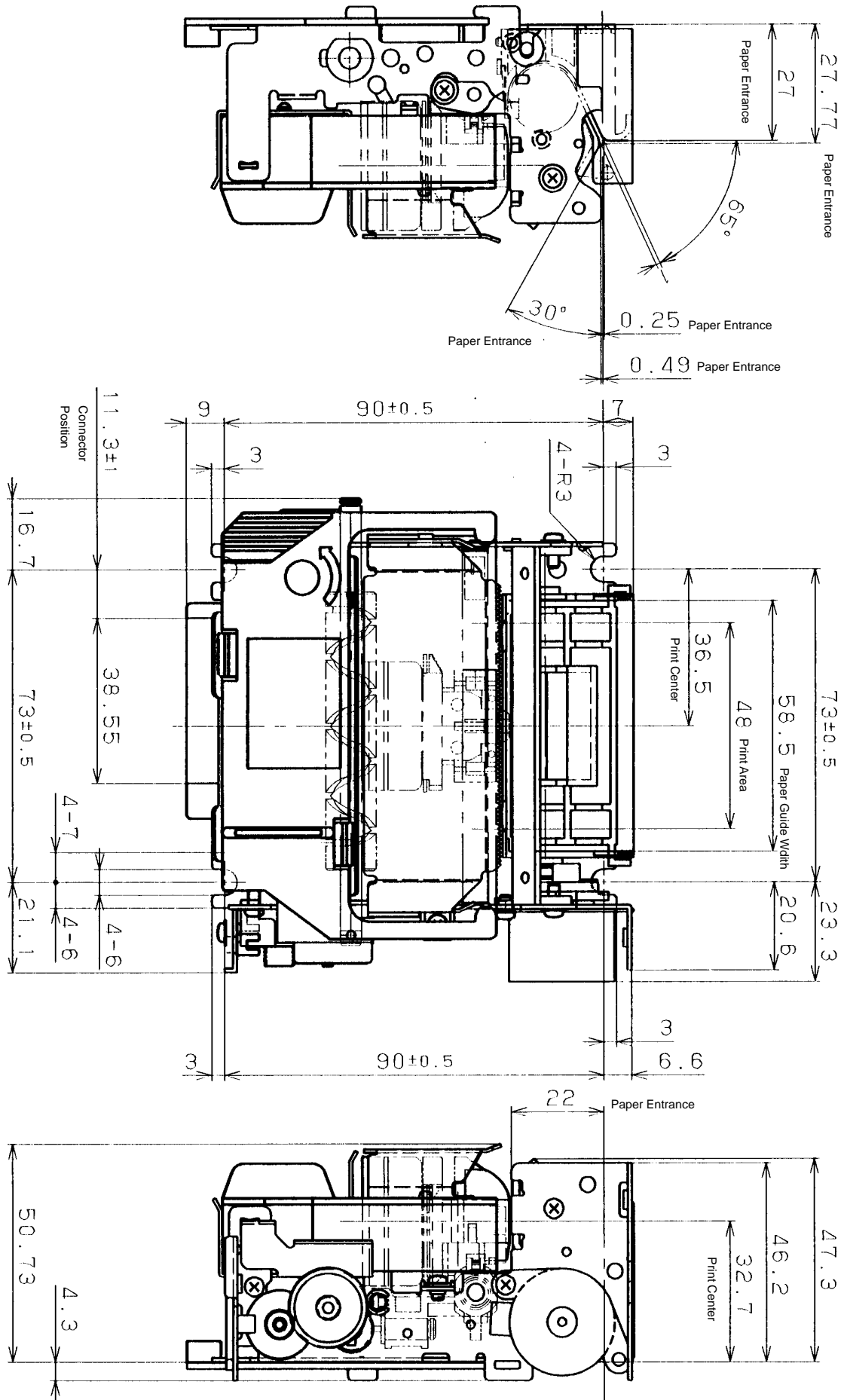

Figure 3-24 MP111MP External dimension (unit: mm)

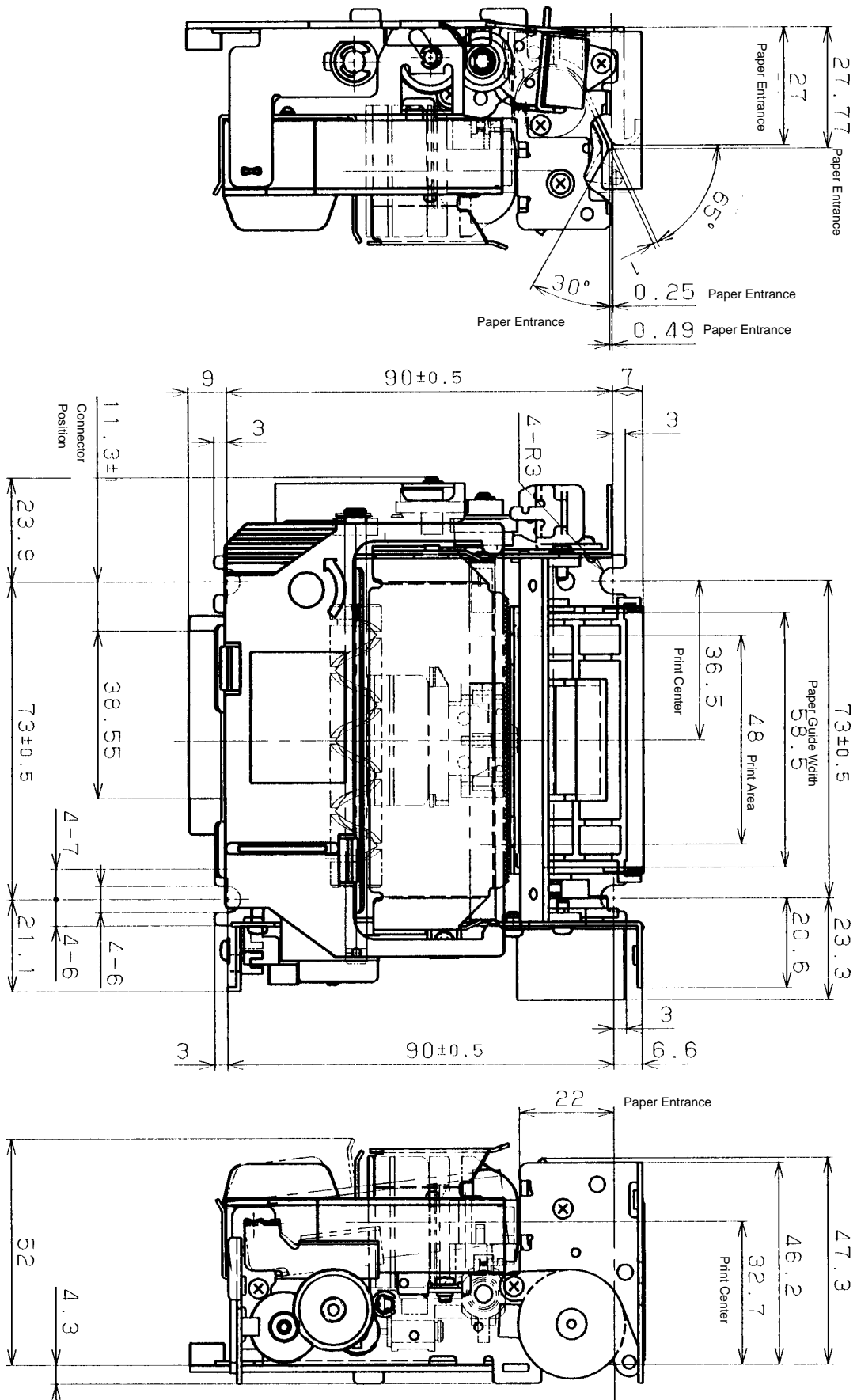

Figure 3-25 MP115MP External dimension (unit: mm)

4. RELIABILITY SPECIFICATIONS

Item		Specification	Remarks
Life	Printer reliability	4 million lines MCBF	Except print head life
	Print head life	Approx. 70 million characters	14 dots per character Recommended ribbon: Purple color ink ribbon cartridge (RC100 P)
Operating environment	Temperature R e l a t i v e humidity	0°C to 50°C 10 to 80% RH (at 40°C) (no condensation)	After being left under this environment for two hours, the printer mechanism must satisfy general specification.
Storage environment	Temperature R e l a t i v e humidity	-20°C to +70°C 5 to 95% RH (at 40°C) (no condensation)	After being left under this environment 96 hours, and under normal temperature and humidity for two hours, the printer mechanism must satisfy general specification.
Vibration test		Vibration : 10 ~ 55 ~ 10 Hz Amplitude : 1.54 mm (at regular range) Sweep : one minute Gravity : 0.3 ~ 9.3 G Direction : X, Y and Z directions Test time : Two hours in each direction (Six hours in three directions) Packing : With the least packing unit	The printer must satisfy general specification after testing.
Shock test		Height : 85 cm Order : 1 corner, 3 edges, and 6 surfaces Packing : With the least packing unit	The printer must satisfy general specification after testing.
Insulation resistance		1 MΩ (100 VDC)	When you put the printer mechanism to the quality control test, use the printer under the environment as shown at the left.

5. SETTING THE RIBBON CARTRIDGE

1. Turn the ribbon feed knob of ribbon cartridge in the direction of the arrow to remove slack in the ribbon.
2. Place the ribbon cartridge and press it to set in the Unit. When the ribbon cartridge is hard to set to the proper position, turn the ribbon feed knob in the direction of the arrow.
Insert the ink ribbon between the print head and the platen.
3. Turn the ribbon feed knob of ribbon cartridge in the direction of the arrow to remove slack in the ribbon.

6. SETTING THE PAPER

6.1 Setting the Paper

1. Cut straight the leading edge of the paper.
2. Insert the paper squarely into the paper guide.
3. Turn the paper feed motor to feed the paper.
4. When the paper comes out of the paper outlet, turn the feed motor off, and stop the paper feed.

6.2 Removing the Paper

1. Cut the paper behind the paper guide.
2. Turn the paper feed motor to remove the paper.

7. INSTALLATION

1. At the time of mounting the printer mechanism into its housing cabinet, put cushion material, such as, rubber foot, on the printer mechanism legs. If installed directly, reverberations occur producing noise. We recommend that you use the following rubber foot.

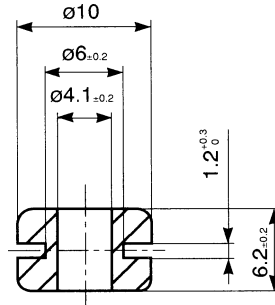

Parts name : DAMPER RUBBER
 SP2
 Parts No. : 30290010

Fig. 7-1 Recommended Rubber foot

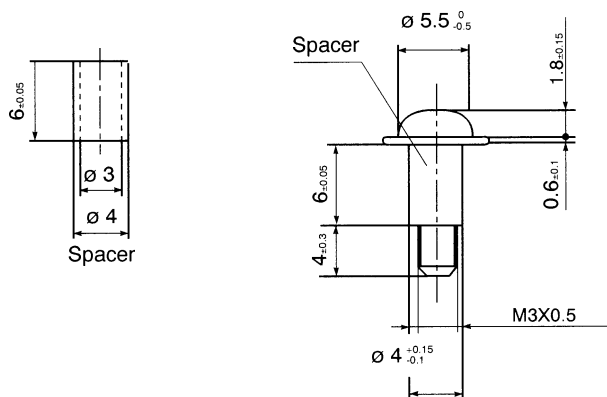

Parts name : SCREW 3.0
 Parts No. : 30250010

Fig. 7-2 Recommended Set screw (unit: mm)

2. Set the play between the roll paper holder and paper thrust direction to within 2 mm, and ensure that the roll paper holder doesn't hold back the edge of paper.
3. Set the paper inserting angle to within 65° .
4. Edges around the paper insertion area should be rounded at R2 mm or more.
5. Set the paper feed load, at the printer's paper inlet, to 30 g or less.
6. Take into account prevention of paper rewinding, when designing the case.
7. Allow needed space surrounding the printer. Fig. 7-3 shows an example of installation space.
8. Fig. 7-4 shows an example of installation.
9. Since this printer mechanism employs galvanized steel panels, the end surface doesn't come plated.

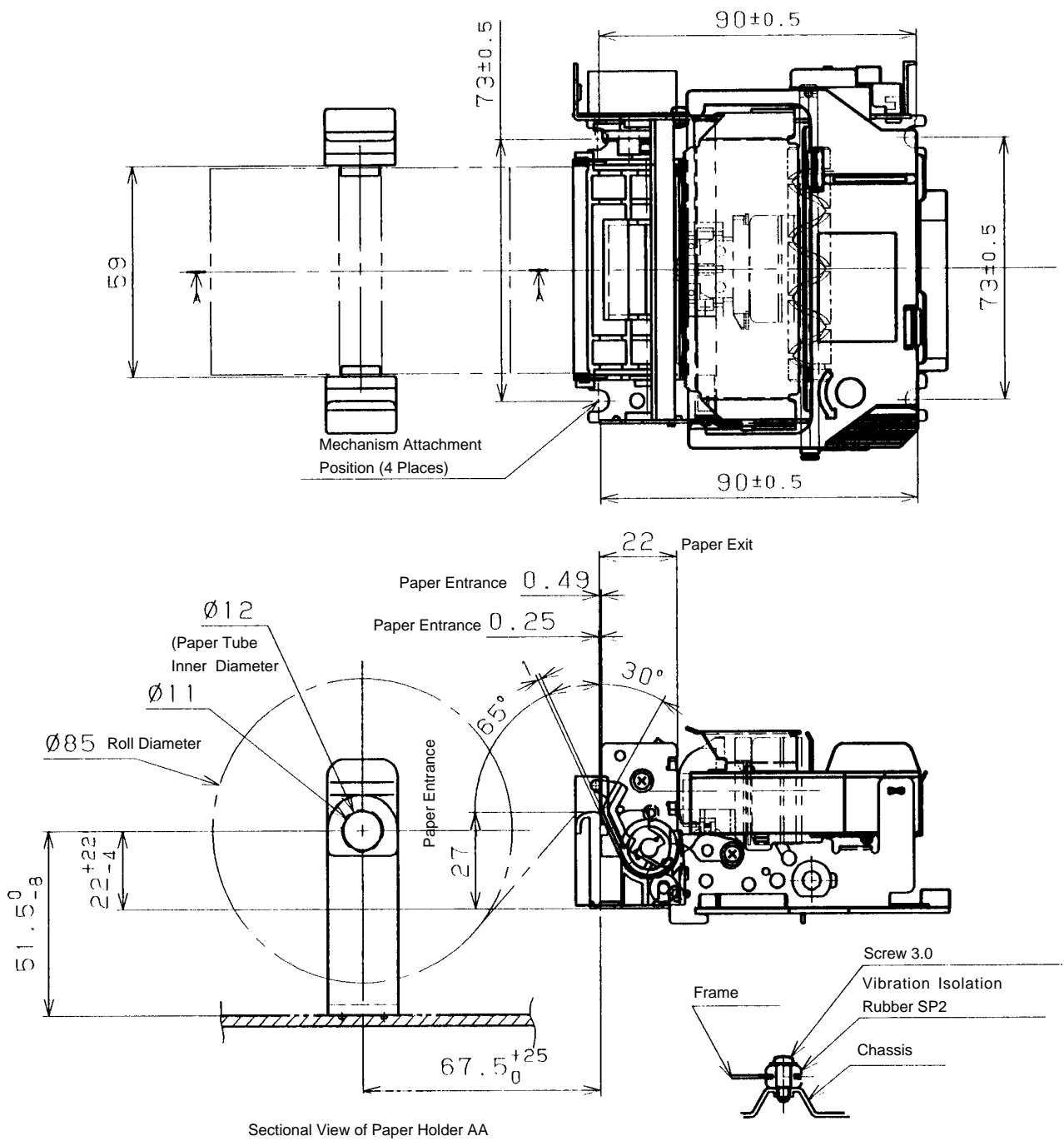

Fig. 7-3 Installation space (example) (unit: mm)

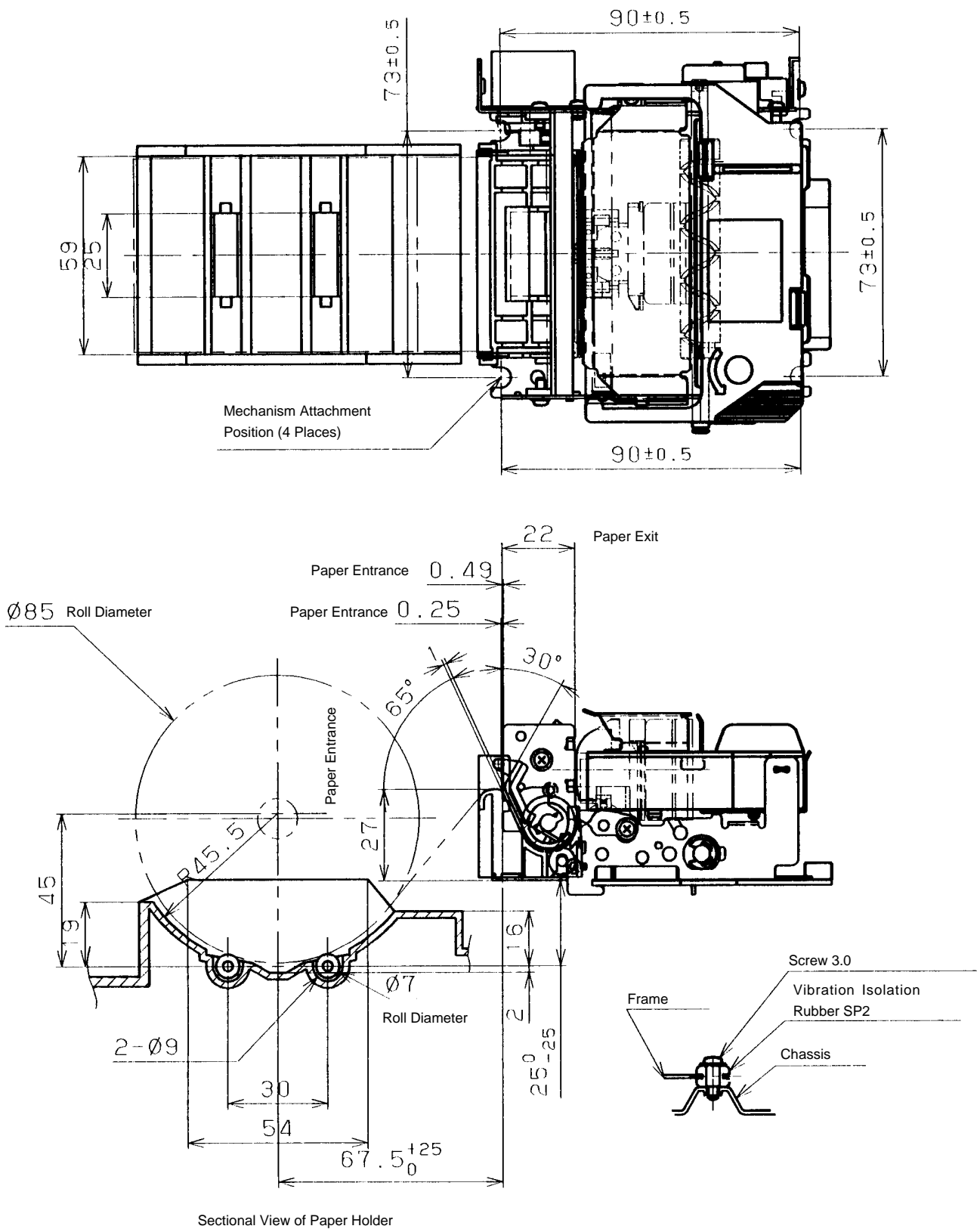
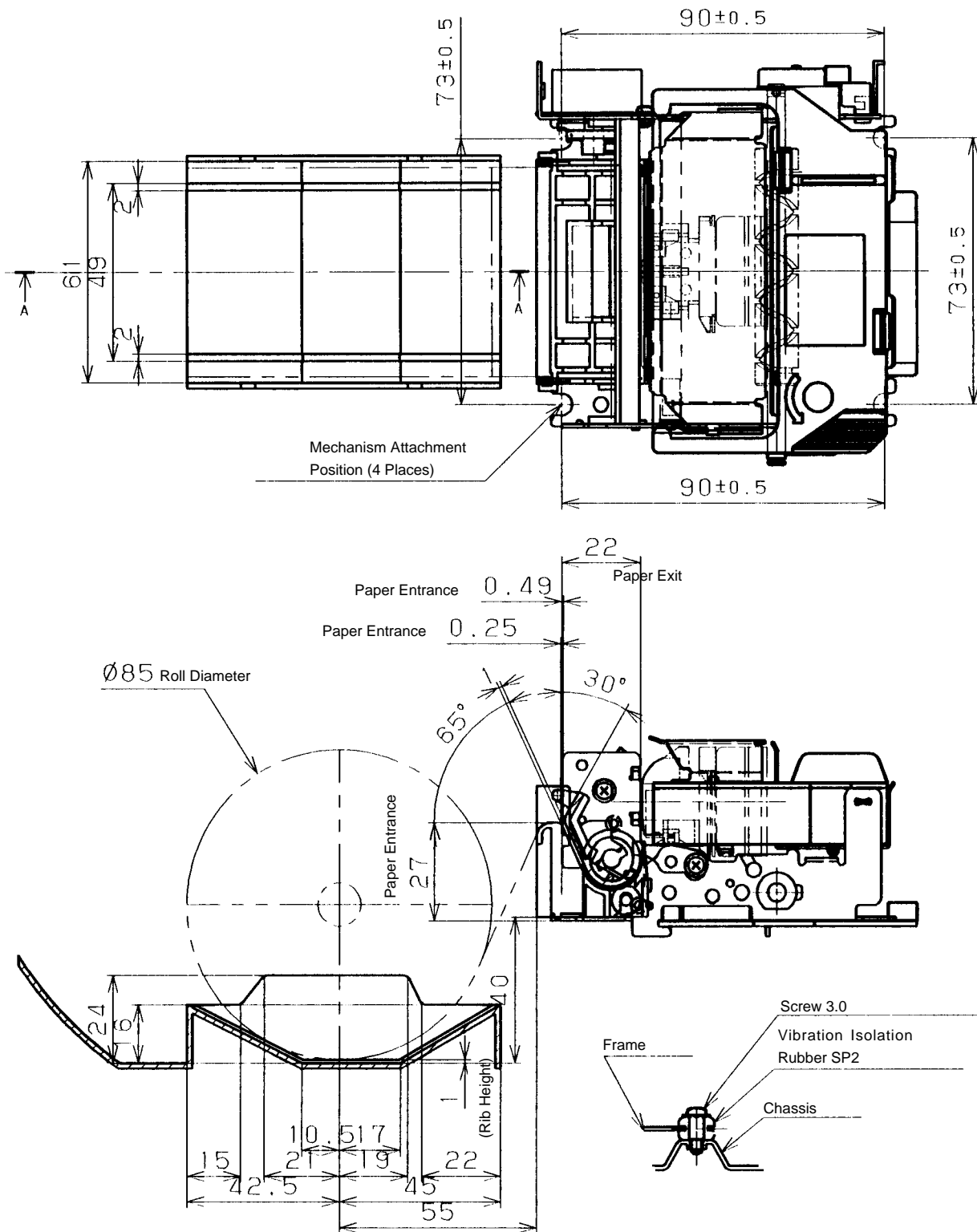

Fig. 7-4 Printer installation (example) (unit: mm)



Sectional View of Paper Holder

Fig. 7-5 Printer installation (Placing the roll paper without using the roller.)

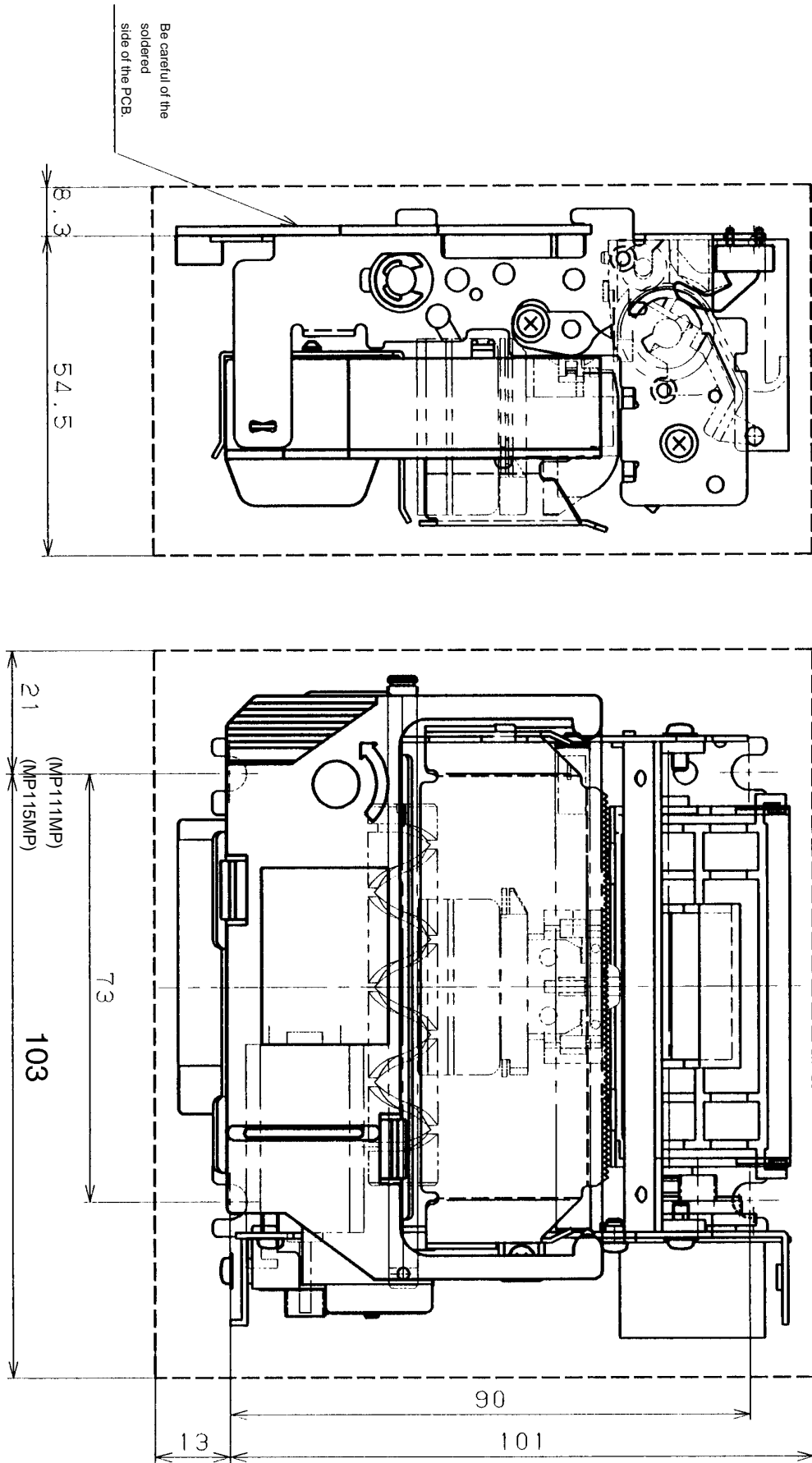

Fig. 7-6 Printer installation

8. OPERATIONAL NOTES

8.1 Power ON/OFF Note

If the 5 V power supply line for logic has not fully risen or fallen immediately after the power supply is turned ON or OFF, the CPU or TTL in the logic circuit may misoperate. At such times, power is supplied to the motor or solenoid, causing, in the worst case, burnt out solenoid or running of motor (misoperation), unless the 24 V power supply line for motor drive is completely OFF. To avoid such misoperation, take into account the following points.

8.1.1 Power supply ON/OFF timing rule

Supply 24 V line after the 5 V line has fully risen. Similarly, cut off the 5 V line after the 24 V line has fully fallen.

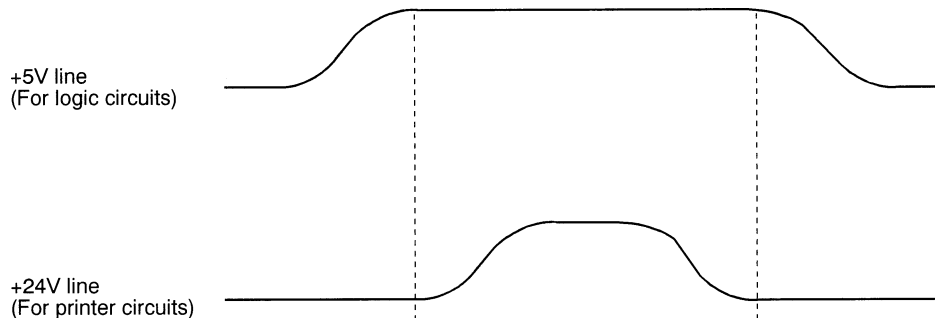

Fig. 8-1 Power supply ON/OFF timing rule

8.1.2 Method of controlling the drive circuit

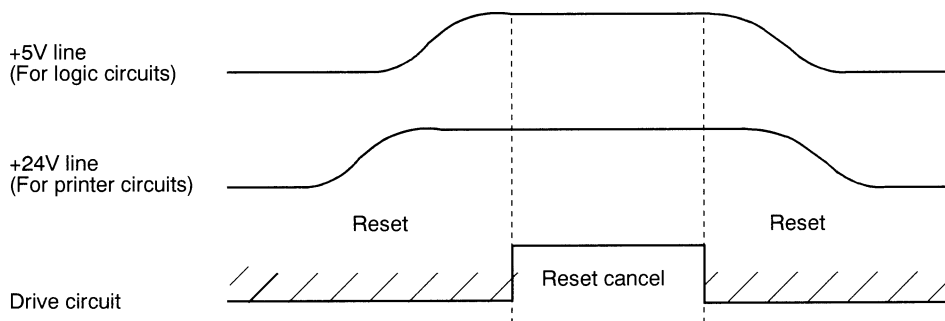

Fig. 8-2 Drive circuit controlling method

If the power supply ON/OFF timing rule cannot be followed, reset the print solenoid or motor drive circuit with control signal. An example of this type of circuit is shown in Fig. 8-3. Turn OFF transistor TR1, while the 5 V line has not completely risen, in order to inhibit power to the print solenoid. Then as soon as the 5 V line has completely risen, turn ON TR1, permitting power to the print solenoid.

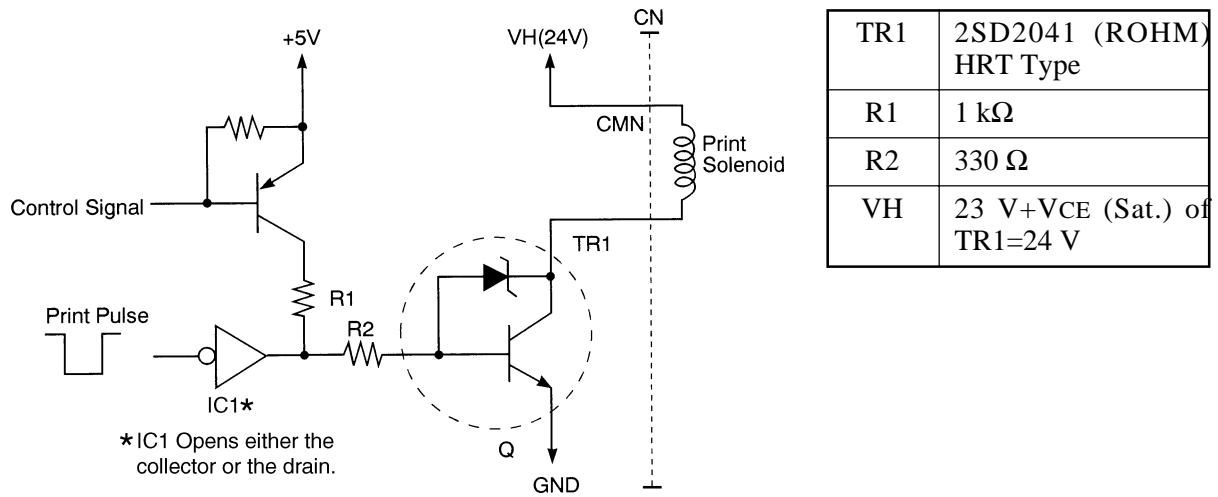

Fig. 8-3 Circuit to control drive circuit (example)

8.2 Carriage Motor Protection Method (Against Mechanical Errors)

If the carriage motor gets locked as a result of trapping foreign matter, etc. in the printer mechanism, a risk of damaging the motor due to flow of excess current to it is generated. Therefore, it becomes necessary to monitor the excess load status of printer mechanism, by detecting the cycle of timing signal 1 with timer, etc. Once the cycle of timing signal 1 becomes as given below, stop power being supplied to the motor.

- a. Print interval: 2.57 ms or more/450 μ s or less
- b. Outside print interval: 257 ms or more

8.3 Other Notes

1. Do not attempt to print when the paper or ribbon cartridge are not loaded in the printer mechanism as this could damage the print head.
2. Do not store or use the printer mechanism at places of substantial dust, iron content, etc., or in oily atmosphere.
3. Wipe off dust, dirt, etc. from the printer mechanism, using a soft brush. Or, wipe with a piece of cloth dampened in alcohol.
4. Never inflict strong force on the printer mechanism. Otherwise, the frame or other parts may be distorted, rendering normal functioning impossible.
5. Avoid sudden changes in the ambient conditions like temperature, humidity, etc. even while they are hold in prescribed limits. If sudden change occurs, allow about 30 minutes for acclimatizing, before using the printer mechanism.
6. Never use the printer mechanism with condensation deposited onto it.

9. POWER SUPPLY CAPACITY

9.1 24 V Line

Arrange for the following power supply, taking into account the voltage drop (about 1 V) of VCE (sat) of the power transistor for driving print solenoid.

Power supply voltage	$23V+1V = 24V \pm 10\%$
----------------------	-------------------------

Similarly, arrange for 2.0 A or larger power supply capacity; and connect an electrolytic condenser of 4700 μ F to 6800 μ F/35 V to the power source.

9.2 5 V Line

Arrange for 5 V power supply for the detector (photo interruptor).

Voltage	$5 V \pm 5\%$
Current consumption	Approx. 60 mA

10. OPTIONS

You can also use 1.75 inch (44.5 mm) width roll paper by removing the paper guide B and attaching the optional guide C.

(1) Removing the Paper Guide B

Spread the boss unit on both sides of the paper guide B and remove the the boss from the paper guide A side. Rotate the paper guide B and remove it.

(2) Setting the Paper Guide C

When you remove the paper guide B, you can see the groove at the right side of the paper guide A. Insert the paper guide C into that groove.

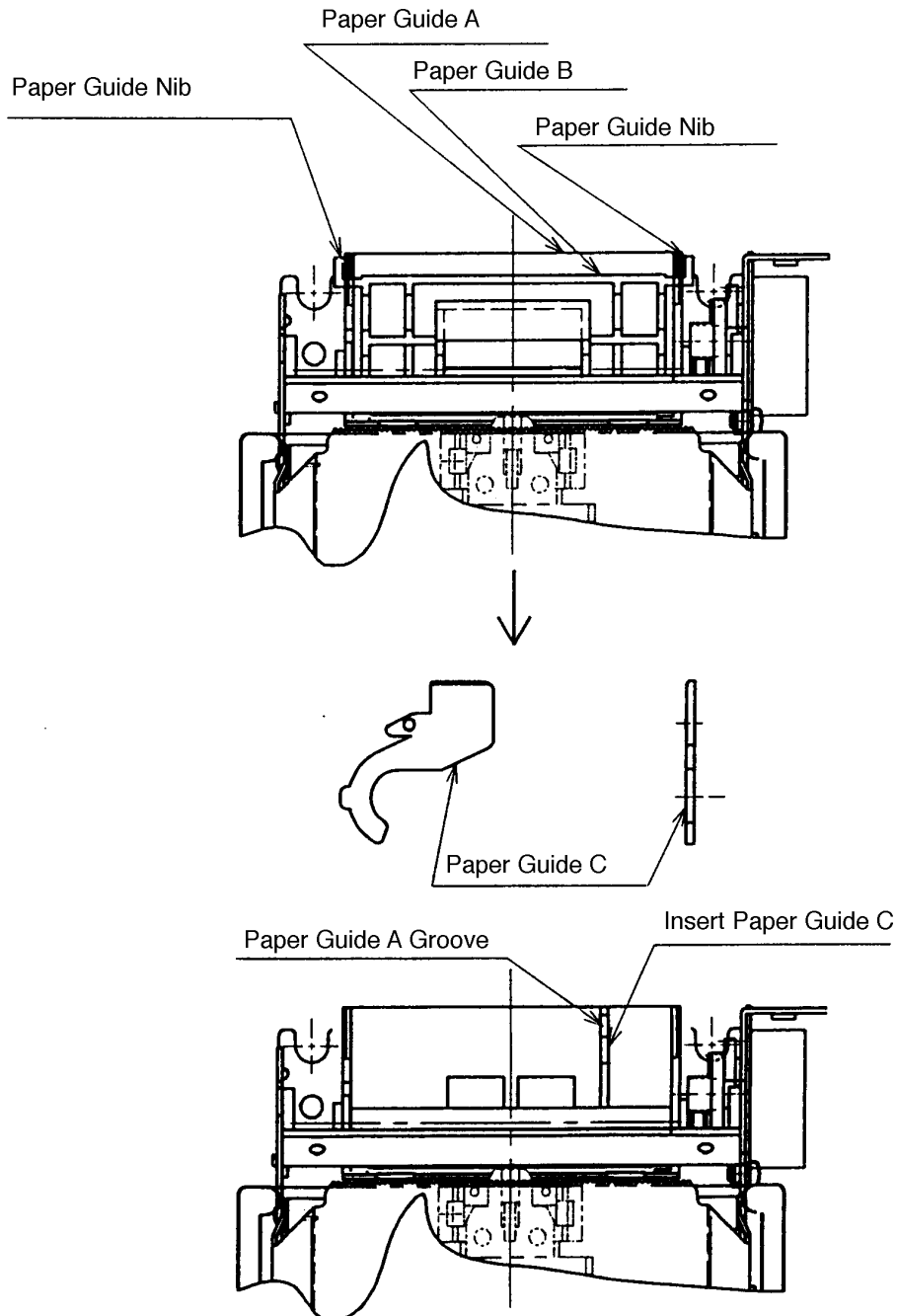

Fig. 10-1 Paper Guide Option



HEAD OFFICE

**ELECTRONIC PRODUCTS DIVISION
STAR MICRONICS CO., LTD.**
536 Nanatsushinya, Shimizu,
Shizuoka, 424-0066 JAPAN
Tel : 0543-47-0112
Fax: 0543-48-5271

**OVERSEAS SUBSIDIARY COMPANIES
STAR MICRONICS AMERICA, INC.**
70-D Ethel Road West,
Piscataway, NJ 08854 U.S.A.
Tel : 732-572-9512
Fax: 732-572-5095

STAR MICRONICS U.K. LTD
Star House, Peregrine Business
Park, Gomm Road, High Wycombe,
Bucks, HP13 7DL, U.K.
Tel : 01494-471111
Fax: 01494-473333

Please access the following URL
http://www.star-micronics.co.jp/service/sp_sup_e.htm
for the latest revision of the manual.

Distributed by

Printed in Japan, 80874315

Free Manuals Download Website

<http://myh66.com>

<http://usermanuals.us>

<http://www.somanuals.com>

<http://www.4manuals.cc>

<http://www.manual-lib.com>

<http://www.404manual.com>

<http://www.luxmanual.com>

<http://aubethermostatmanual.com>

Golf course search by state

<http://golfingnear.com>

Email search by domain

<http://emailbydomain.com>

Auto manuals search

<http://auto.somanuals.com>

TV manuals search

<http://tv.somanuals.com>