

MULTI-FONT+SLQ
XB24-10

MULTI-FONT+SLQ
XB24-15

USERS MANUAL

NOT INTENDED FOR SALE

Self Declaration

Radio interference regarding this equipment has been eliminated according to Vfg 1046/1984 announced by the DBP.

DBP has been informed of the introduction of this special equipment and has been granted the right to examine the whole series.

It is the user's responsibility to see that his own assembled system is in accordance with the technical regulations under Vfg 1046/1984.

To conform to FTZ-regulations it is necessary to make all connections to the printer with shielded cable.

The equipment may only be opened by qualified service representatives.

The above statement applies only to printers marketed in West Germany.

Trademark Acknowledgements

XB24-10, XB24-15, NB-15, NB24-10, NB-24-15: Star Micronics Co., Ltd.

IBM PC, PC-AT, PC-XT, Proprietary X24/XL24, Proprietary II, PC-DOS: International Business Machines Corp.

Microsoft BASIC, MS-DOS: Microsoft Corporation

Pinwriter P6/P7: NEC Corporation

LQ-850, LQ-1000, LQ-1050, LQ-1500: Seiko Epson Corp.

WordStar: MicroPro International Corporation

NOTICE

- All rights reserved. Reproduction of any part of this manual in any form whatsoever without STAR's express permission is forbidden.
- The contents of this manual are subject to change without notice.
- All efforts have been made to ensure the accuracy of the contents of this manual at the time of press. However, should any errors be detected, STAR would greatly appreciate being informed of them.
- The above notwithstanding, STAR can assume no responsibility for any errors in this manual.

© Copyright 1989 Star Micronics Co., Ltd.

CONGRATULATIONS

Thank you for buying this printer. This printer is provided with the following features:

- High-quality 24-pin print head
- 3 print modes - Draft, Letter Quality and Super Letter Quality
- Many different typefaces built into the printer
- Epson, NEC or IBM Proprinter compatibility including graphics
- Comprehensive paper-handling facilities (cut-sheet or tractor as standard, with optional Automatic Sheet Feeder)
- Paper-park facility for loading cut-sheet paper without having to unload fanfold paper
- Memory Switch facility, enabling comprehensive programming from the front panel
- Optional color facilities
- IC card slot for extra RAM or provision of ROM fonts

ORGANIZATION OF THIS MANUAL

This manual is divided into 9 chapters. Use chapters 1 through 3 as a "User Guide", giving you information on how to set up and start your printer. The remaining chapters may be treated as a reference guide for programming operations, etc. It assumes a degree of knowledge off the operation of computers (for instance, it assumes you know about hexadecimal numbers). The chapters are as follows:

Chapter 1 - Introduction

Read this section first, as it explains how to unpack and install your printer.

Chapter 2 - Front panel controls

There are a number of controls on the front panel which perform various functions related to paper handling, print modes and font selection. This section shows you how to use the front panel controls.

Chapter 3 - Setting up the Memory Switches

Your printer has a Memory Switch function, which allows you to make certain system settings from the front panel. This section explains the operation of these Memory Switches.

Chapter 4 - Emulations and escape codes

This chapter explains the different emulations provided by your printer, and the software commands used to drive it. This section is of use if you are writing or modifying programs to take advantage of the printer's features.

Chapter 5 - DIP Switches

This section explains how to set the DIP switches to make system settings on the printer.

Chapter 6 - MS-DOS and your printer

Since the PC or PC-AT family of computers running under MS-DOS is currently the most popular configuration of microcomputer, we have included a few hints and tips to help you use your printer with such systems. Since virtually all PCs are sold with a Microsoft BASIC interpreter, we have also included some hints, and a sample program in this language to demonstrate the capabilities of the printer.

Chapter 7 - Troubleshooting and maintenance

This section give a checklist of points to check if your printer is not working in the expected way. It also includes details of some routine maintenance operations you can carry out yourself. It is not, however, a complete service manual. Call a qualified service engineer if you are unsure of your ability to carry out any maintenance or servicing operations.

Chapter 8 - Specifications

This section gives the specifications of your printer.

Chapter 9 - Character sets

These charts give the different character sets available, and the differences between national character sets (as set up with the DIP switches).

TABLE OF CONTENTS

Chapter 1 INTRODUCTION	1
LOCATING THE PRINTER	1
UNPACKING, SETTING UP AND CONNECTION	1
Setting up	3
Connection	5
LOADING PAPER	7
Cut-sheet paper	7
Fanfold paper (continuous) stationery	8
Once the paper has been loaded	10
Chapter 2 FRONT PANEL CONTROLS	11
CONTROLS AND INDICATORS	11
Controls	11
Indicators	11
PITCH SETTING	12
Pitch Panel Lock	12
QUALITY SETTING	12
Mode Panel Lock	13
FONT SETTING	13
Font Panel Lock	13
QUIET MODE	14
PAPER HANDLING	14
Form feed	14
Paper parking	14
Short tear-off function	15
Micro Feed	16
BUFFER CLEAR/RESET	16
TEST AND MAINTENANCE SETTINGS	16
Chapter 3 SETTING UP THE MEMORY SWITCHES	17
MENU OPTIONS	19
Command Menu	19
Font menu	19
Print Menu	20
Paper Menu	20
Forms Menu	21
Factory settings	22

Chapter 4	EMULATIONS AND ESCAPE CODES	23
	EMULATIONS	23
	NUMERICAL REPRESENTATION	23
	COMMAND CODES AND ESCAPE SEQUENCES	24
	Font style and character set control codes	26
	Font pitch control codes	30
	Special print mode control codes	33
	Line space control codes	38
	Form feed control codes	43
	Margins and vertical tab setting control codes	45
	Horizontal print position control codes	48
	Downloaded character control codes	53
	Graphics	56
	Miscellaneous codes	60
	ASCII command sequences	69
Chapter 5	DIP SWITCHES	73
Chapter 6	TROUBLESHOOTING AND MAINTENANCE	75
	TROUBLESHOOTING	75
	Power supply	76
	Printing	76
	Paper feeding	78
	EVERYDAY MAINTENANCE	81
	ADJUSTING THE PRINTING GAP	81
	RIBBON REPLACEMENT	82
	REPLACING THE PRINT HEAD	84
	FRONT PANEL DIAGNOSTIC AND	
	TEST MODES	86
	Short test mode	86
	Long test mode	87
	Text test mode	88
	Hexadecimal dump mode	89
	Bidirectional test/adjustment mode	90
Chapter 7	MS-DOS AND YOUR PRINTER	93
	INSTALLING APPLICATION SOFTWARE	
	WITH YOUR PRINTER	93
	GRAPHICS HARD COPY	95
	SETTING UP THE PRINTER FROM THE DOS PROMPT	95
	PROGRAMMING USING BASIC	96
	Sample program	96
	How the program works	100
	Patches necessary to use the BASIC interpreter	103

Chapter 8 SPECIFICATIONS	105
Chapter 9 CHARACTER SETS	109
STANDARD CHARACTER SET #1	110
Family 1	110
Family 2	112
Family 3	114
Family 4	116
STANDARD CHARACTER SET #2	118
Family 1	118
Family 2	118
Family 3	119
Family 4	119
IBM CHARACTER SET #2	120
Family 1	120
Family 2	122
Family 3	124
Family 4	125
IMB CHARACTER SET #1	127
ADDITIONAL CHARACTER SET	128
INTERNATIONAL CHARACTER SETS	129
 INDEX	 131

Chapter 1

INTRODUCTION

The following section covers the unpacking and installation of your printer, together with information on paper loading and handling (both continuous and cut-sheet paper).

LOCATING THE PRINTER

Before you start unpacking and setting up your printer, make sure that you have a suitable place on which to locate it. By “a suitable place”, we mean:

- A firm, level surface which is fairly vibration-free
- Away from excessive heat (ie away from direct sunlight and away from heaters, etc)
- Away from excessive humidity
- Away from excessive dust
- A location with sufficient space to locate the printer and any paper to be fed into it, as well as the printed paper coming out
- If you are using a parallel connection to your computer, make sure that it is within 2m (6ft) of the printer (an RS-232 connection using the optional RS-232 interface can be made over longer distances).

UNPACKING, SETTING UP AND CONNECTION

Now unpack the contents of the printer shipping container, and make sure that you have the following:

- The printer itself
- Paper guide assembly
- The platen knob
- A fabric ribbon

If any of these items are missing, contact your supplier.

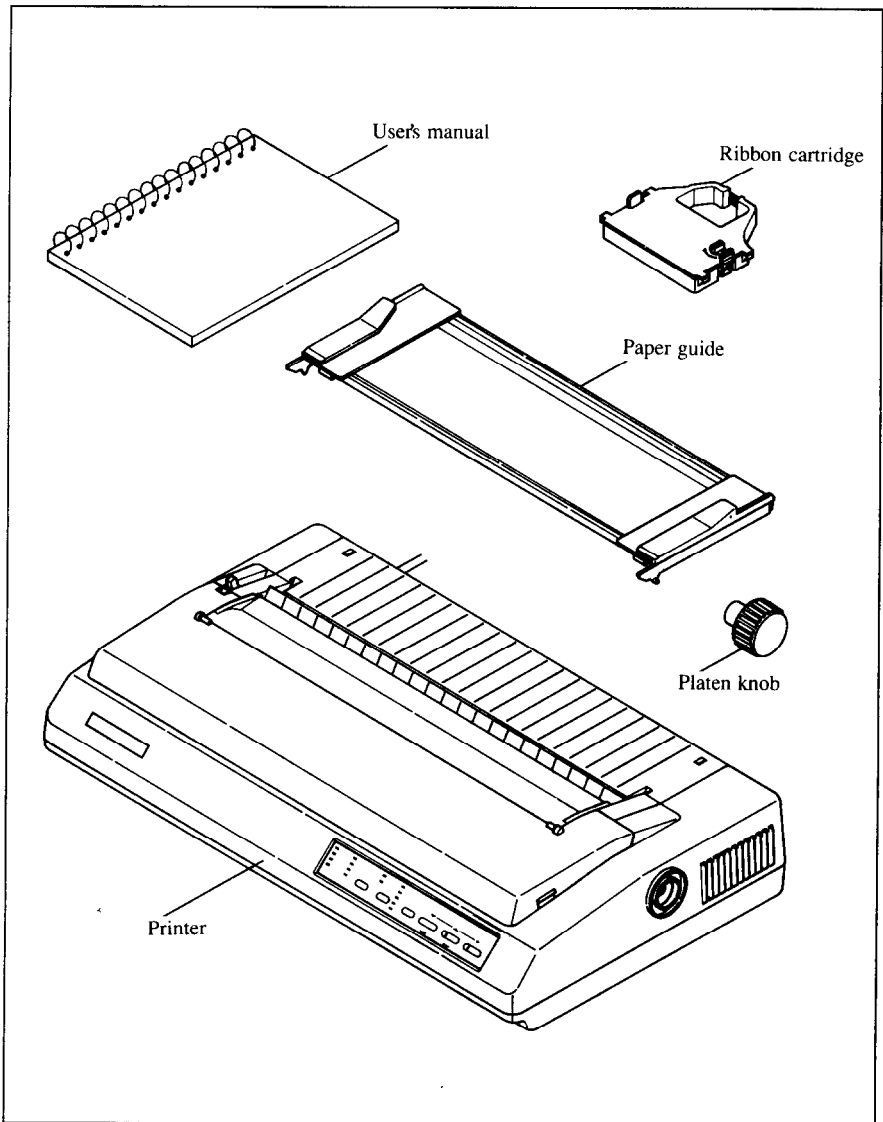

The optional accessories which you may have ordered with your printer are:

- Serial (RS-232) interface board
- Automatic sheet feeder
- Color option kit

See the installation instructions contained with these optional items for details of how to attach them to your printer.

Setting up

Place your printer in the position where it is going to be permanently sited, and remove all packing material from inside the top cover. This packing material is intended to prevent damage to the printer in transit. You may like to keep this packing with the printer carton if you intend transporting the printer for use at a different location.

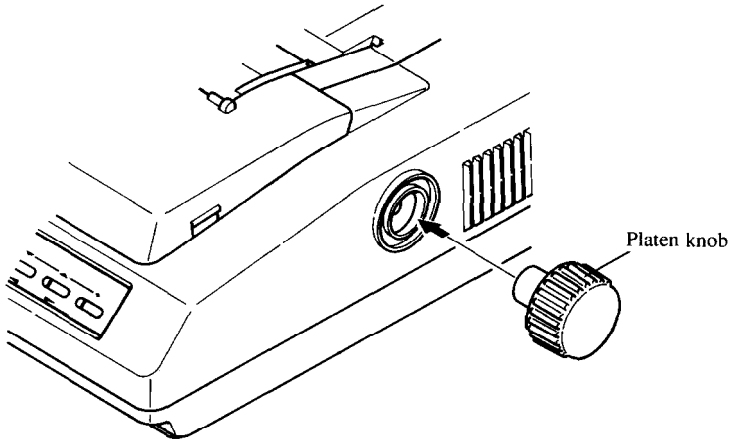

The platen knob should be removed from the accessory box inside the shipping carton. Mount the platen knob on the shaft on the right-hand side of the printer. Turn the knob on the shaft before pushing the knob fully into position.

NOTE

Before turning the platen knob, always ensure that the power to the printer is OFF. Turning the platen knob when the power is on can damage the printer's gears.

Remove the top cover by lifting the front (using the two grips at the side), and pulling towards you. Now install the ribbon.

- 1 Use the tensioning knob on the ribbon cartridge to tighten the ribbon if it is slack (turn clockwise).
- 2 The ribbon should pass between the print head and the print head shield (see illustration below).

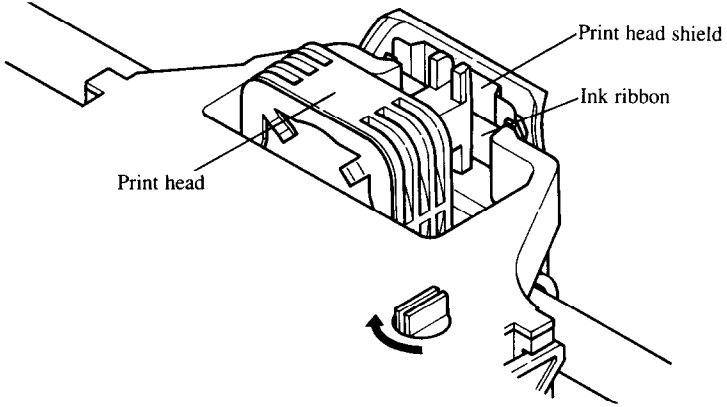

- 3 Use the grips on the side of the ribbon cartridge to help locate the cartridge (squeeze them inwards gently), and make sure that the spindles on the cartridge holder fit into the sockets on the cartridge itself.

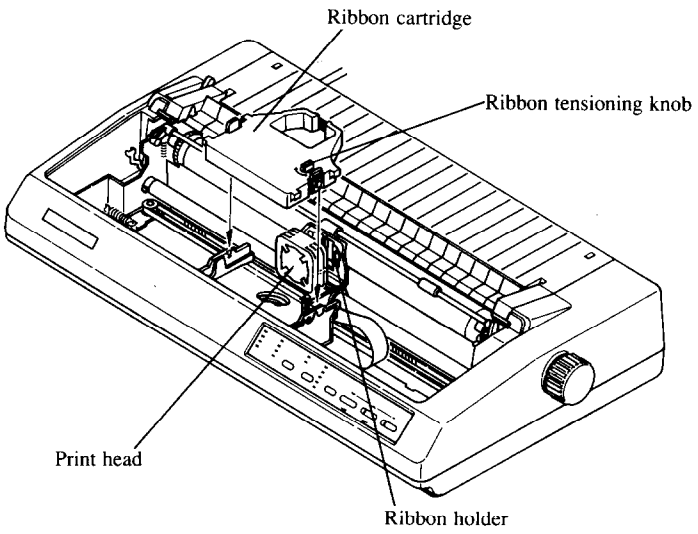

Connection

Connect the printer to your computer, using a standard parallel-type cable. On a PC or PC/AT-type computer, this means that you use the 25-way D-type connector at the computer end, and the Amphenol-type 36-way connector at the printer end. The pinouts of the printer's connector are given in Chapter 8 if you need a cable for connection to another computer. Plug the printer into a suitable mains outlet. However, **DO NOT** turn on the power switch at the back of the printer yet.

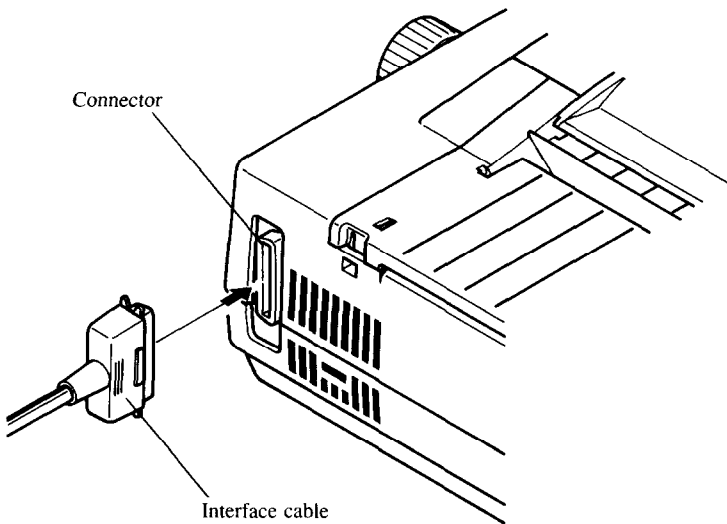

You may need to set some DIP switches inside the printer before you start using it. These switches enable you to configure the printer as an Epson or as an IBM Proprinter printer. The DIP switches also enable you to select a character set other than the USA character set, if your supplier has not already set these up for you. The DIP switch cover is located inside the top cover (see below). Use the end of a paper-clip (or similar) to set the switches. Details of these switches are given in Chapter 5. If you feel unsure as to your ability to set these switches, contact your supplier.

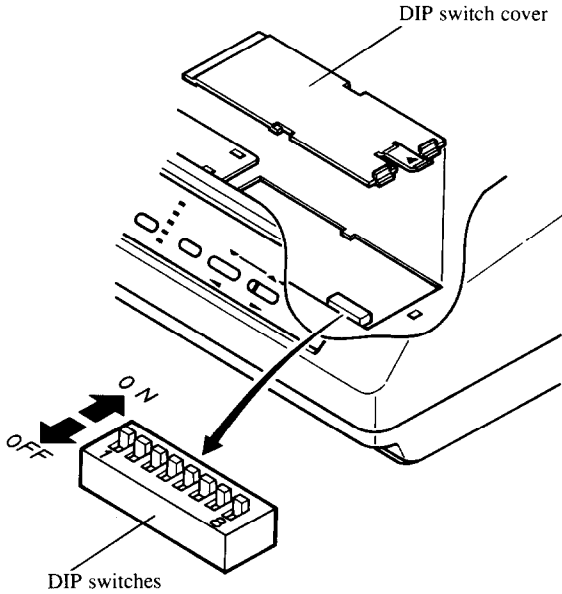

LOADING PAPER

The following sections explain how to load paper - single-sheet (cut-sheet), without the Automatic Sheet feeder, and also the operations necessary for loading continuous (fanfold) stationery.

If you are using the Automatic Sheet Feeder, please refer to the instructions supplied with the Automatic Sheet Feeder unit.

Cut-sheet paper

- 1 Place the paper guide in position, locating the lugs on the bottom of the assembly into the slots on the printer body.
- 2 Make sure that the release lever is pushed towards the back of the printer ( position).
- 3 Adjust the paper guides to match the size of paper you will be using (remembering that printing will start some distance from the left-hand edge of the carriage). There are markings molded into the back plate of the assembly to help you if you wish to center the paper. If you are centering the paper using the markings molded into the paper guide, remember that *printing will start from the left-hand edge, unless you reset the left and right margins using software commands.*
- 4 Place the paper between the guides, placing the side on which you want to print towards the back of the printer. Gently push the paper down in the guides until you feel it stop.

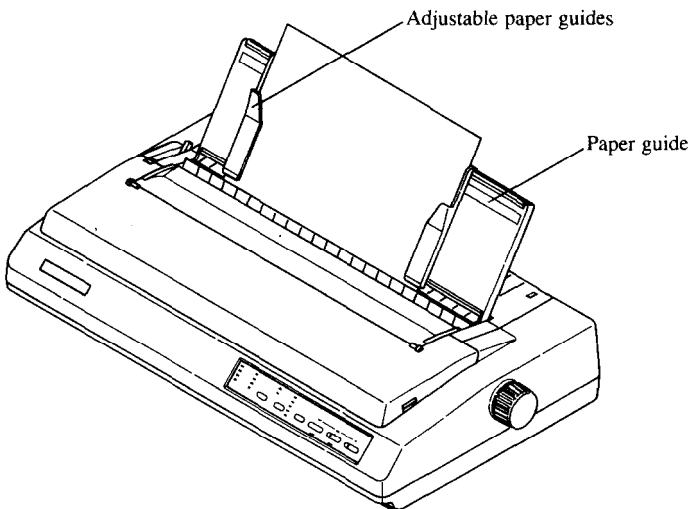

- 5 Turn on the power using the switch at the back of the printer. The printer will beep, indicating that no paper is in position for printing. The orange PAPER indicator also shows this.
- 6 Now press the **SET/PAPER** button. The paper bail will move clear of the paper, and the paper will be fed and adjusted past the print head to a position ready for printing. The paper bail will be moved back to grip the paper against the platen, and the print head will move to the start position.

The actual vertical position of the paper after auto-loading is determined by the Memory Switch setting (see Chapter 3).

The vertical position of the paper can be finely adjusted by means of the micro feed function (see Chapter 2).

Fanfold paper (continuous) stationery

If you are going to use fanfold (continuous) paper, then you will need to use the integral tractor mechanism assembly, situated under the rear cover of the printer.

- 1 Remove the top and rear covers of the printer to insert the paper.

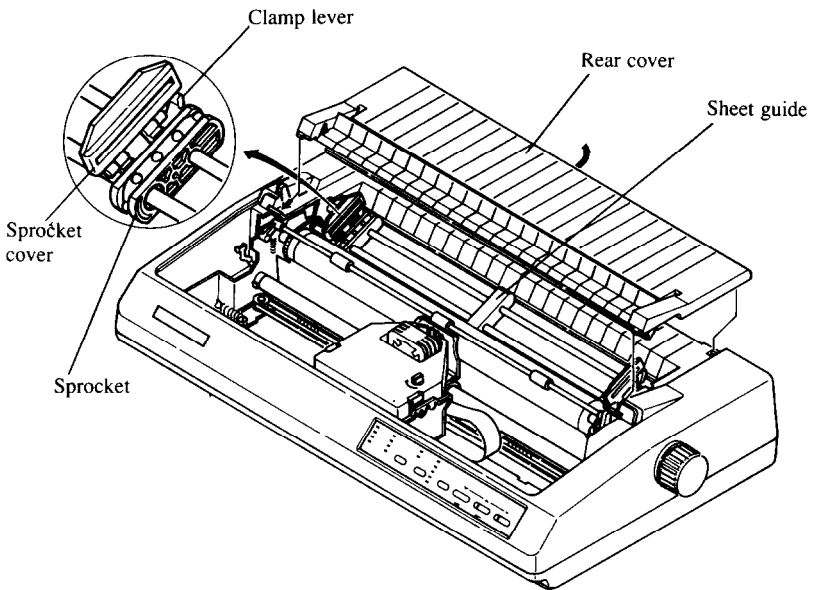

- 2 Push the release lever towards the front of the printer (to the  position). This has the effect of releasing the paper from the platen roller, and engaging the tractor feed.
- 3 With the sprocket covers open, thread the paper over the sprockets, aligning the sprocket holes with the pins on the sprockets.
- 4 Adjust the spacing of the sprockets by sliding them along the bar, using the clamp lever at the back of each sprocket to release and lock the sprocket in position (when the lever is up, the sprocket may be moved, and when it is down, the sprocket is locked).

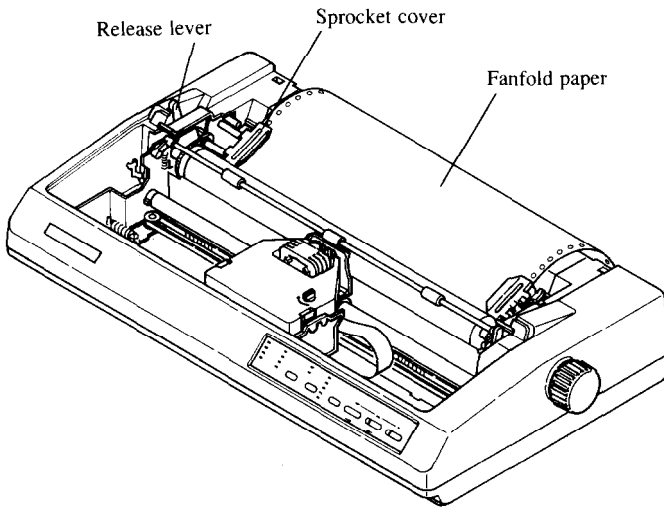

- 5 Now close the sprocket covers, again making sure that the paper sprocket holes are aligned with the pins on the sprockets. If they are not aligned properly, you will have problems with paper feeding, possibly resulting in tearing and jamming of the paper.
- 6 Turn on the printer using the switch at the back of the printer. The printer will beep (indicating that the paper is not yet fully loaded). This is also confirmed by the orange PAPER indicator.

- 7 Now press the **SET/PARK/EJECT** button. The paper bail will move clear of the paper, and the paper will be fed and adjusted past the print head to a position ready for printing. The paper bail will be moved back to grip the paper against the platen, and the print head will move to the start position. As when loading cut-sheet paper, the Memory Switch setting will determine the initial position of the paper after auto-feeding, and the micro feed function may be used to adjust the paper position.
- 8 Remount the top cover rear cover and the transparent printer cover.
- 9 Remount the paper guide as shown below:

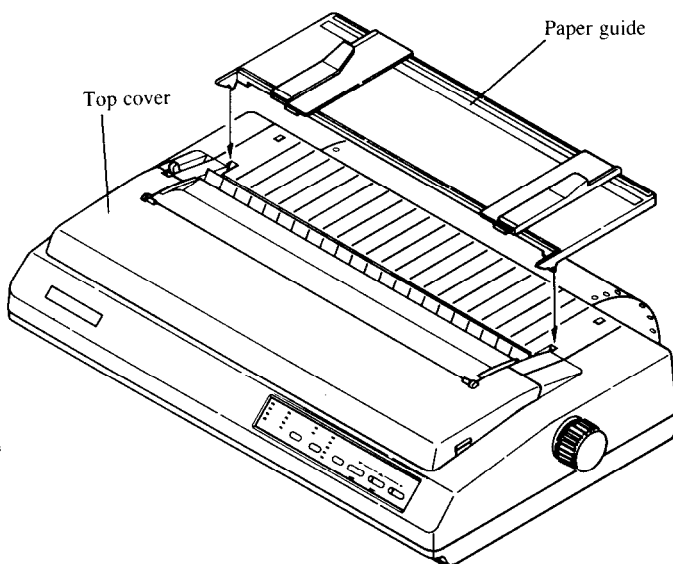

Once the paper has been loaded

The printer will now be on-line (the ON LINE indicator will be lighted). You may now want to choose a font, a pitch and a print quality. This can be done from the front panel, but you must put the printer off-line first by pressing the **SET/PARK/EJECT** button. The indicator will go out and the printer will beep to confirm this.

Chapter 2

FRONT PANEL CONTROLS

The following section describes the front panel controls and indicators on your printer, together with a description of the functions performed by them.

CONTROLS AND INDICATORS

The following is a brief guide to the controls and indicators on the front panel.

Controls

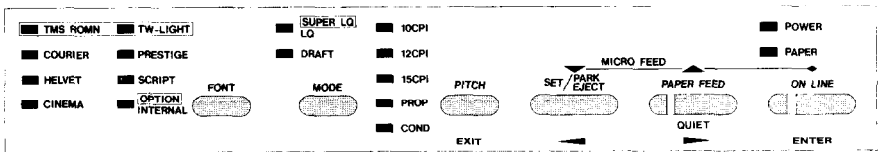

The printer is equipped with six buttons: from left to right they are, **FONT**, **MODE** and **PITCH** (smaller buttons), and **SET/PARK/EJECT**, **PAPER FEED** and **ON LINE** (larger buttons).

Indicators

The first three buttons have a series of indicators next to them which show which option has been currently selected using them (font, mode or pitch). Some of these indicators can be either orange or green, depending upon the options currently selected.

There is no indicator associated with the **SET/PARK/EJECT** button (as its operation is obvious when paper has been inserted), but the **PAPER FEED** and **ON LINE** buttons both have indicators embedded in the buttons themselves. The indicator embedded in the **PAPER FEED** button, however does not indicate paper feed directly, but indicates (when illuminated) whether Quiet mode has been selected (see below). The **ON LINE** button also has an embedded indicator. Pushing the **ON LINE** button will alternately set the printer on- and off-line and illuminate or extinguish the indicator.

In addition to these indicators, there are two others, POWER and PAPER. The POWER indicator will illuminate when power is supplied to the printer, and the PAPER indicator will illuminate when no paper has been inserted.

PITCH SETTING

Use the **PITCH** button to set the pitch that will be printed. Remember that the printer must be off-line for you to do this. Successive presses of this button will illuminate (and select) the following options in this order:

Pitch	Indicator(s)
10 characters per inch	10CPI
12 characters per inch	12CPI
15 characters per inch	15CPI
17 characters per inch	10CPI, COND
20 characters per inch	12CPI, COND
Proportional	PROP
Proportional condensed	PROP, COND

Holding down this button will cycle continuously between these options.

Pitch Panel Lock

If the **PITCH** button is pressed when the printer is turned on, the pitch will be “locked”, and no pitch changes can be made from software. It is still possible, however, to put the printer off-line and change the pitch using the **PITCH** button.

QUALITY SETTING

The printer is capable of 3 print quality modes: Super Letter Quality (SLQ), Letter Quality and Draft. Successive presses of the **MODE** button will alternate between these three settings (the SLQ mode is indicated by the top indicator showing orange). Remember that the printer must be off-line for you to do this. Holding down this button will cycle continuously between these three options. However, not every typeface can be printed in every mode (see the table below for details of what fonts are available in each mode), and so the FONT indicator may change as you change the mode.

Mode Panel Lock

If the **MODE** button is pressed when the printer is turned on, the mode will be “locked”, and no mode changes can be made from software. It is still possible, however, to put the printer off-line and change the mode using the **MODE** button.

FONT SETTING

Pressing the **FONT** button will illuminate a font indicator. Remember that the printer must be off-line for you to do this. Note that the selection of some fonts (shown in yellow on the front panel) is shown by an orange indicator, and the selection of others (shown in green on the front panel) is shown by a green indicator. Note that not every font is available in every mode (see the table below). Holding down the **FONT** button will cycle continuously between the fonts available for the mode selected.

Mode	Font
SLQ	TMS ROMN
	TW-LIGHT
	OPTION (when font IC card is installed)
LQ	TMS ROMN
	TW-LIGHT
	COURIER
	PRESTIGE
	HELVET
	SCRIPT
	CINEMA
	OPTION (when a font IC card has been installed)
	INTERNAL (when font has been downloaded)
DRAFT	NO FONT SELECTED



Font Panel Lock

If the **FONT** button is pressed when the printer is turned on, the font will be “locked”, and no font changes can be made from software. It is still possible, however, to put the printer off-line and change the font using the **FONT** button.

QUIET MODE

To select Quiet mode, the printer must be on-line. While it is on-line, press the  button. This will alternately illuminate and extinguish the QUIET indicator. When in Quiet mode, the printer will print slightly slower, but at a reduced noise level.

NOTE





If you press the  button while the printer is off-line, the  button will perform its normal function, ie it will feed paper.

PAPER HANDLING

The following sections describe the ways in which you can control paper feeding, etc by means of the front panel controls:

Form feed

A form feed can be achieved from the front panel in the following way:



- 1 Put the printer off-line, by pressing the  button, so that the indicator is extinguished.
- 2 Press the  button, and keep it depressed.
- 3 Press the  button momentarily.
- 4 The paper will then move forward to the top of the next sheet (fanfold paper), or eject a cut sheet.
- 5 Set the printer on-line again () to resume printing.

Paper parking

Paper parking is useful if you are using fanfold paper, and you want to print a document on one or two sheets of cut-sheet paper. The printer "parks" the fanfold paper safely out of the way, so that you do not need to unload the paper before inserting cut-sheet paper, then, when you have finished printing on cut-sheet paper, moves the fanfold paper back to its original position so that you can restart printing.





To use this facility, follow the instructions below:

- 1 Put the printer off-line (press the  button, so that the indicator goes out).

- 2 Press the  button, so that the fanfold paper is moved out of the paper path.
- 3 Now move the release lever to the rear of the printer ( position) to select cut-sheet paper (disengaging the fanfold sprockets).

NOTE

If you do not move the release lever at this stage, the printer will warn you at the next step by emitting a continuous series of beeps.

- 4 Insert the cut sheet paper in the paper guides
- 5 Press the  button in order to feed the cut sheet to the starting print position. The printer will automatically go on-line.
- 6 Print as normal on the cut sheet(s), and when you have finished printing, put the printer off-line (by pressing the  button again).
- 7 If the software has not done this for you, eject the paper by pressing the  button.
- 8 Move the release lever to the front of the paper ( position) to select fanfold paper (engaging the fanfold sprockets).
- 9 Now feed the fanfold paper to the print position by pressing the  button. The paper will move to its former print position, and the printer will automatically go on-line.

You are now ready to start printing on fanfold paper again.

Short tear-off function

The short-tear-off function is handy when using fanfold paper. It ejects the paper so that the perforation is just above the transparent cover, allowing you tear it off without having to open up the printer. It then reverses the paper feed after you have torn off the paper, thereby starting printing at the top of the next form. This feature is especially useful if you are using pre-printed stationery (such as invoices, etc), which will not be printed all together.

To use the short tear-off function, press the  button when the printer is on-line, and hold it down for a few seconds. When you release the button, the printer will go off-line, and the paper will move up a few inches, allowing you to tear off the form.

To return the paper to its previous position, press the **ON LINE** button once again. When you release the button, the printer will return to its on-line status, and the paper will be fed backwards, with the print head aligned with the top of the next form.

Micro Feed

The Micro Feed facility is useful if you wish to align the paper exactly. It feeds the paper forwards or backwards in 1/120th inch increments.

To use this feature, put the printer off-line (using the **ON LINE** button).

Then press the **ON LINE** button, and either the **PAPER FEED** button (to feed the paper forwards), or the **SET/PAPER FEED** button (to feed the paper backwards).

Holding down these buttons continuously will continue to feed the paper forwards or backwards in small increments.

BUFFER CLEAR/RESET

It is possible to clear the buffer of the printer or to return it to its power-on status by using the front panel buttons without having to turn the power off and on. To do this, put the printer off-line (press the **ON LINE** button), and then press the **ON LINE** button again. Before releasing the **ON LINE** button, hold down the **FONT** button. Releasing the **FONT** button within two seconds of holding it down (before releasing the **ON LINE** button) will clear the data in the buffer. Releasing the button after two seconds (again, before releasing the **ON LINE** button) will reset the printer back to the settings at power-on.

TEST AND MAINTENANCE SETTINGS

The printer is equipped with a number of functions to assist testing and maintenance. Since it is anticipated that they will not be used very often, they are not described here, but in Chapter 6.

However, briefly, they are:

- A text test print mode
- A short test print mode
- A long test print mode
- A hexadecimal dump mode
- A bidirectional print test

Chapter 3

SETTING UP THE MEMORY SWITCHES

In addition to the pitch, print mode and font, many other options regarding the setup of the printer can be carried out from the front panel. To access these options, it is necessary to turn off the printer, and then turn it on again, while holding down the **ON LINE**, **PAPER FEED** and **SET/PARK/EJECT** buttons together. This will cause the printer to print a series of questions and options to which you can answer using the front panel buttons. This is called the Memory Switch mode.

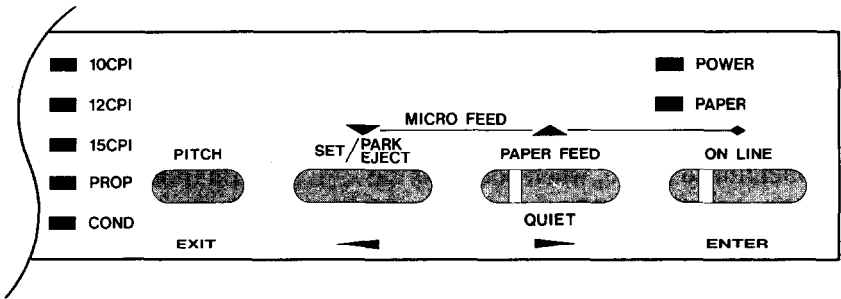

The principle involved is that the printer will print a list of options on one line. You use the **SET/PARK/EJECT** and **PAPER FEED** buttons to move the print head so that it is below the option you want to choose.

The printer will move the paper up and down as appropriate, so that the menu options are visible.

The **SET/PARK/EJECT** button moves the print head one option to the left, and the **PAPER FEED** button moves one option to the right (as marked in blue on the front panel under the buttons). Holding down one of these buttons will still move the print head only one option forward or back.

When the print head is below the desired option, press the **ON LINE** button to enter this into the printer's memory. Any option chosen at this stage will now be stored, even when the printer is turned off.

When you press the **ON LINE** button to enter an option, a "*" (asterisk) will be printed to confirm that the option has been chosen.

The menus are organized in a hierarchical (tree-structured) fashion. Some menus do not choose options directly, but instead, move down to other menus. To move up through the menu structure towards the "root" or "trunk", use the **PITCH** button as an **EXIT** button (as marked in blue underneath the button).

The structure of the menus is shown below.:

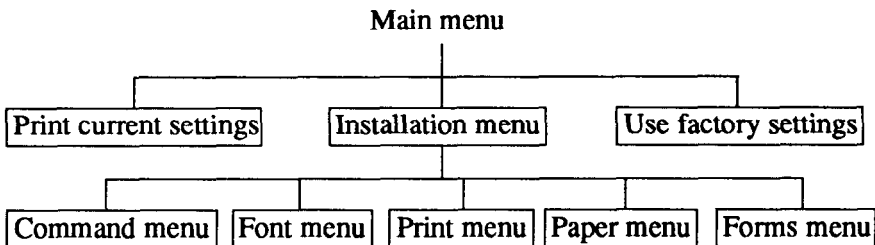

The options within each menu are given below.

As mentioned above, when you press the **EXIT** button from any sub-menu or from an option within a menu, you will return to the menu level above the current one. If you press the **EXIT** button from the main menu, the printer will print "***END***" and exit to being on-line, with the settings chosen in Memory Switch mode being now set in the printer.

MENU OPTIONS

The following is a list of the options within the menus, and their meanings, together with the prompts printed in Memory Switch mode. The prompts are given in capital letters in square brackets, thus: [OFF]. Factory settings are marked here with an asterisk (for example, [ON*]). A summary of factory settings is also provided following this section.

Command Menu

This menu allows you to set up various parameters controlling the overall setup of the printer:

RAM USAGE	The printer RAM may be used as a print buffer [BUFFER*], for downloading fonts [DOWNLOAD], or as a single-line buffer [1LINEBUFFER].
QUIET MODE	The printer may either print slower and quieter [ON], or faster, making slightly more noise [OFF*].
GRAPHICS DIRECTION	When printing in graphics mode, the printer may either print bidirectionally (in alternate directions) for speed [BI*] or in one direction only (unidirectional for increased accuracy [UNI]). For practically all purposes, however, bidirectional printing is sufficiently accurate.
AUTO ON-LINE	If this is set [ON*], then when paper is inserted, the printer will automatically come on-line. If set [OFF], then you will have to press the button to bring the printer on-line.

Font Menu

This menu allows you to set two parameters concerning fonts which will be automatically selected whenever you turn on the printer:

ZERO STYLE	In computer usage, a zero is often written with a slash through it, as follows: "0". This style is called [SLASHED]. If a zero is written as a slightly thinner capital "O", without the slash ("O"), this may be chosen by selecting [NORMAL*].
SLQ/LQ FONT	This option allows you to choose the default font selected when SLQ or LQ mode is selected. All available fonts are given as options. The default is [COURIER*].

Print Menu

This menu allows you to set up various printing options which will be automatically selected whenever you turn the printer on:

PRINT QUALITY	This will select either Super Letter Quality / Letter Quality [SLQ, LQ*] or Draft [DRAFT] mode.
PRINT PITCH	You may select a print pitch of either [10CPI*], [12CPI] or [15CPI] (“CPI” stands for “characters per inch”), or proportional spacing [PROP].
CONDENSED PRINT	You may select condensed print to be either [OFF*] or [ON] at power-up.
ITALIC PRINT	You may select italic printing to be either [OFF*] or [ON] at power-up.
DRAFT-12	When in draft print mode, you may select either high-speed and low density [HI-SPEED*] or high-density and low-speed printing [HI-DENSITY].

Paper Menu

OPTION ASF	With this option, you may select or cancel the Automatic Sheet Feeder option [OFF*] or [ON].
AUTO LOADING	When you load paper automatically, this option determines the number of lines by which the paper will be fed forward from the top of the paper. The options range from 1 to 6, and the factory setting is 6.
AUTO LOADING (ASF)	This option, like the one above, determines the number of lines by which the paper will be fed forward from the top of the paper, but here the option is determined for the Automatic Sheet Feeder. Again, the options range from 1 to 6, and 6 is the factory setting.
PAPER-OUT DETECTOR	Frequently, the printer will detect the lack of paper and go off-line with a number of beeps if no paper is inserted in the printer [ON*]. However, this can be disabled [OFF].

Forms Menu

This menu allows you to set various options associated with paper handling:

SHORT TEAR OFF	When using fanfold (continuous) paper, this Short Tear Off option allows you to tear off one sheet of paper without having to eject the whole of the following sheet. If this option is set [ON*], when the paper reaches the top of the form, it will automatically be advanced a little, allowing you to tear off the paper easily. Set this option to [OFF] if you do not want to use it.
SKIP OVER PERFORATION	When using fanfold (continuous) paper, you may wish printing to stop a little before the bottom of each sheet, and start printing a little after the beginning of the next (in other words, skipping over the perforation). This is useful if you want to produce program listings, etc. This can be enabled by setting this option [ON], or, if using software which performs this function automatically, it can be set [OFF*].
AUTO LF	If set [ON], this will expand all received carriage return codes to a line feed and carriage return pair. However, this may be set [OFF*] if your software demands it.
AUTO CR	If set [ON*], this function will expand all received line feed codes to a carriage return and line-feed pair. However, this may be set [OFF] if you do not want to be expanded.
LINES PER INCH	This sets the number of lines per vertical inch which will be printed to [3 LPI], [4 LPI], [6 LPI*] or [8 LPI].
PAGE LENGTH	The page length may be set by means of the DIP switches [DIP-SW*] (see Chapter 5 for details) or to any of the following lengths (in inches): [3], [3.5], [4], [5.5], [6], [7], [8], [8.5], [11.7] or [14]. A4 paper is equivalent to 11.7 inches, while the DIP switch settings of 11 inches and 12 inches will normally be used for fanfold paper.

Factory settings

The following is a list of the settings set up at the factory, which may be restored by choosing the FACTORY SET option from the main menu:

COMMAND MENU

RAM USAGE	[BUFFER]
QUIET MODE	[OFF]
GRAPHICS DIRECTION	[BI]
AUTO ON-LINE	[ON]

FONT MENU

ZERO STYLE	[NORMAL]
SLQ/LQ FONT	[COURIER]

PRINT MENU

PRINT QUALITY	[SLQ, LQ]
PRINT PITCH	[10CPI]
CONDENSED PRINT	[OFF]
ITALIC PRINT	[OFF]
DRAFT-12	[HI-SPEED]

PAPER MENU

OPTION ASF	[OFF]
AUTO LOADING	[6 LINES]
AUTO LOADING (ASF)	[6 LINES]
PAPER-OUT DETECTOR	[ON]

FORMS MENU

SHORT TEAR OFF	[ON]
SKIP OVER PERFORATION	[OFF]
AUTO LF	[OFF]
AUTO CR	[ON]
LINES PER INCH	[6 LPI]
PAGE LENGTH (INCH)	[DIP-SW]

Chapter 4

EMULATIONS AND ESCAPE CODES

EMULATIONS

The printer has two emulation modes: standard mode and IBM mode.

In standard mode, the printer emulates the functions of the Epson LQ-850 and LQ-1050 printers, as well as the NEC Pinwriter. Additional command codes are included as a superset of these emulations.

In IBM mode, the printer emulates the IBM Proprinter X24/XL24 printers. Additional command codes are included as a superset of these emulations.

The emulation is changed by means of DIP switch 1. When ON, the printer will be in standard mode, and when OFF, the printer will be in IBM emulation mode (see Chapter 5). It is not possible to change the emulation mode by means of software control or the front panel controls.

NOTE

Remember to turn off the printer before making any DIP switch changes.
--

NUMERICAL REPRESENTATION

When in either standard or IBM mode, any numerical parameters taken by command sequences are usually binary rather than ASCII numerical values. In this manual, any ASCII values will be represented in quotes, eg "21" will represent the ASCII string 32h concatenated with 31h (in BASIC, CHR\$(50)+CHR\$(51)). Usually in these examples, however, hexadecimal values will be quoted, as shown by the lowercase "h" following the number, eg 32h.

Binary numbers over FFh are obtained by dividing the number into two bytes, the first being the low byte, and the second being the high byte. In this way, the value 123h will be divided into the two following bytes: 23h and 01h.

If negative numbers are required, they are obtained by subtracting the absolute value of the negative number from 65536 (10000h), and dividing the result into high and low bytes. For instance, to represent the number -10h, the following operation is carried out:

10000h - 10h = FFF0h

and the result is divided into the two bytes of F0h and FFh.

If "non-printable" codes are given, ie those codes from 00h through 1Fh and 7Fh, these codes will be enclosed in angle brackets, for example <DC1>. The name in the angle brackets is that assigned to the code in the ASCII convention. The name of the character should not be used, the binary value should be input. In the same way, it should be noted that the angle brackets are not to be input - they are merely there as delimiters in the printed text.

Of course, in a program, a meaningful variable name can be given to these characters, for instance (the following example is written in BASIC):

```
10 ESC$=CHR$(27) : BS$=CHR$(8)
20 LPRINT ESC$;BS$;
```

COMMAND CODES AND ESCAPE SEQUENCES

Some command codes are common to both the standard and IBM modes. In the descriptions of the command codes, all command codes will be given, together with a note of the modes to which each command code is applicable.

Most of the following command codes are available in both the standard mode and the IBM emulation mode. If a command is common to both modes, the descriptive heading is followed by "Both". If the command is specific to one mode, then either "Standard" or "IBM" will follow the descriptive heading. Occasionally, there are two identical commands to perform the same function. In these cases, the relevant sign follows the escape sequence.

When parameters are given, the accompanying text describes whether the parameter is an ASCII character or a binary value.

In the following descriptions, first the function of the command sequence is given. This is followed by the emulation for which this command is appropriate ("Standard", "Both" or "IBM").

Following the heading, the full form of the command is given, using the ASCII names for control codes, eg <ESC> (the angle brackets on either side of the name are not part of the name, being simply delimiters, and should not be entered). Variable parameters are indicated by a letter (usually “n”), and an optional number, enclosed in angle brackets (eg <n0>). Where an indefinite number of parameters are to be supplied, the <n>s are separated by an ellipsis (“...”). The sequence is then given using hexadecimal codes (two hexadecimal digits followed by a lowercase “h”), with variables again represented by letters enclosed in angle brackets. The decimal equivalent follows the hexadecimal. The following is an example:

Example command			Both
<ESC>	<BS>	<n>	(codes)
1Bh	08h	<n>	(hexadecimal)
27	8	<n>	(decimal)

Note that the above command sequence is for example purposes only - it does not have any real function.

Font style and character set control codes

Select Italic characters		
<ESC>	4	Standard
1Bh	34h	
27	52	
<FS>	4	IBM
1Ch	34h	
28	52	

The sequence above selects italic character printing. There are no parameters. This command will not be valid if the Font Panel Lock has been selected.

Deselect Italic printing		
<ESC>	5	Standard
1Bh	35h	
27	53	
<FS>	5	IBM
1Ch	35h	
28	53	

The sequence above deselects italic printing. There are no parameters. This command will not be valid if the Font Panel Lock mode has been selected.

Select print mode			Both
<ESC>	x	<n>	
1Bh	78h	<n>	
27	120	<n>	

This command selects the print mode for subsequent printing, where <n> may be a binary value of 00h or 01h, or either of the ASCII characters "0" or "1" (30h or 31h). If <n> is equal to 00h or "0", then Draft mode will be selected, and if equal to 01h or "1", then LQ or SLQ mode will be selected. All other parameters are invalid. This command will also be ignored if Mode Panel Lock has been selected.

Select font			
<ESC>	k	<n>	Both
1Bh	6Bh	<n>	
27	107	<n>	
<FS>	C	<n>	Standard
1Ch	43h	<n>	
28	67	<n>	

The command above selects a typeface for subsequent printing, where <n> is a binary value in the range of 00h to 15h. The following table shows the effect of different values of this parameter:

Binary Value	Selected font	Binary Value	Selected font
00h	TMS ROMN	09h	Orator
01h	TW-LIGHT	0Ah	Helvet
02h	Courier	0Bh	Optimo
03h	Prestige	0Ch	Cinema
04h	Script	0Dh	CODE 39
05h	OCR-B	0Eh	Greek
06h	OCR-A	10h	Option
07h	Letter-Gothic	14h	SLQ TMS ROMN
08h	Blippo	15h	SLQ TW-LIGHT

Any other parameters are invalid and will be ignored. This command will also be ignored if Mode Panel Lock has been selected.

Select/Deselect 12cpi draft mode			Standard
<FS>	S	<n>	
1Ch	53h	<n>	
28	83	<n>	

The command above selects or deselects 12cpi draft mode, where <n> can be an ASCII or binary value of either "0" or 00h or "1" or 01h. If <n>=00h or "0", then 180dpi mode will be selected, and if <n>=01h or "1", then 120dpi mode will be selected.

Select character table			
<ESC>	t	<n>	Both
1Bh	74h	<n>	
27	116	<n>	
<FS>	I	<n>	Standard
1Ch	49h	<n>	
28	73	<n>	

The command above will select the character table to be used in subsequent printing, where <n> can be a binary or ASCII value from 00h through 02h or "0" through "2". The following table shows the effect of this parameter:

Value of <n>	Description
00h or "0"	Selects standard character table
01h or "1"	Selects IBM character table
02h or "2"	Moves character set downloaded in 00h to 7Fh area to 80h to FFh area

Any other values are invalid and will be ignored.

Select primary character set		Both
<ESC>	7	
1Bh	37h	
27	55	

The command above selects the primary character set. There are no parameters. The area from 80h to 9Fh is used for control codes.

Select secondary character set		Both
<ESC>	6	
1Bh	36h	
27	54	

The command above selects the secondary character set. There are no parameters. The area from 80h to 9Fh is used for printable characters.

Select International character set			
<ESC>	R	<n>	Standard
1Bh	52h	<n>	
27	82	<n>	
<FS>	R	<n>	IBM
1Ch	52h	<n>	
28	82	<n>	

The command above selects an international character set, where <n> is a binary value in the range 00h through 0Dh. The character set selected is dependent on the value of <n>, as shown in the table below:

Value of <n>	International character set	Value of <n>	International character set
00h	USA	07h	Spain I
01h	France	08h	Japan
02h	Germany	09h	Norway
03h	England	0Ah	Denmark II
04h	Denmark I	0Bh	Spain II
05h	Sweden	0Ch	Latin America
06h	Italy	0Dh	Denmark/Norway

Any other values of <n> are invalid and will be ignored. The special characters affecting each symbol set are given in Chapter 9.

Print continuously from the All Characters Chart				IBM
<ESC>	\	<n0>	<n1>	
1Bh	5Ch	<n0>	<n1>	
27	92	<n0>	<n1>	

The command above allows a series of special characters to be printed from the control code area (00h thru 1Fh), where the two parameters give the total number of characters to be printed (low byte first). On receipt of this command, any codes received in the range 00h through 1Fh will not be interpreted as control codes, but will print the characters corresponding to those codes. This will continue for the number of characters designated by <n0> and <n1>.

Print a single character from the All Character Chart IBM	
<ESC>	^
1Bh	5Eh
27	94

The command above prints a single character from the All Characters Chart. There are no parameters. If the next character to be printed has a code between 00h and 1Fh, it will not be treated as a control code, and the character corresponding to this code will be printed.

Font pitch control codes

Set pica pitch printing	Standard
<ESC>	P
1Bh	50h
27	80

The command above sets all subsequent printing to pica pitch. There are no parameters. This command will be ignored if Pitch Panel Lock has been selected. It may be cancelled by a <ESC>M (elite pitch set) or a <ESC>g (semi-condensed pitch set) command.

Set pica pitch printing	IBM
<DC2>	
12h	
18	

The command above sets the print pitch to pica. There are no parameters. This command is ignored if Pitch Panel Lock mode has been selected.

Set elite pitch printing	Both
<ESC>	M
1Bh	4Dh
27	77

The command above sets all subsequent printing to elite pitch. There are no parameters. This command will be ignored if Pitch Panel Lock has been selected. It may be cancelled by a <ESC>P (pica pitch set) or a <ESC>g (semi-condensed pitch set) command.

Set elite pitch printing		IBM
<ESC>	:	
1Bh	3Ah	
27	58	

The command above sets the print pitch to elite. There are no parameters. This command is ignored if Pitch Panel Lock mode has been selected.

Set semi-condensed pitch printing		Standard
<ESC>	g	
1Bh	67h	
27	103	

The command above sets all subsequent printing to a pitch of 15 characters per inch. There are no parameters. This command will be ignored if Pitch Panel Lock has been selected. It may be cancelled by a <ESC> P (pica pitch set) or a <ESC> M (elite pitch set) command.

Set condensed print mode		Both
<ESC>	<SI>	
1Bh	0Fh	
27	15	
<SI>		
0Fh		
15		

Either of the two commands above will set condensed print mode, unless semi-condensed pitch set printing was previously selected. There are no parameters. Subsequent printing will take place at approximately 1.7 times the number of characters/ inch than was previously the case. This is cancelled on receipt of a <DC2> command. This command will be ignored if Pitch Panel Lock mode has been selected.

Cancel condensed print mode	Standard
<DC2>	
12h	
18	

The command above cancels the condensed print mode. There are no parameters. On receipt of this command, all subsequent printing will be done at the pitch selected prior to a <ESC> <SI> or <SI> command. This command will be ignored if Panel Pitch Lock mode has been selected.

Select/cancel proportional printing	Both
<ESC> p <n>	
1Bh 70h <n>	
27 112 <n>	

The sequence above selects or cancels proportional printing, where <n> is a binary or ASCII value from 00h through 01h or "0" through "1". If <n>=00h or "0", then proportional printing is deselected (cancelled), and if <n>=01h or "1", then proportional printing is selected. There are four types of proportional printing that may be selected:

- Proportional
- Condensed proportional
- Superscript/Subscript proportional
- Superscript/Subscript condensed proportional

Set or cancel pica proportional pitch	IBM
<ESC> P <n>	
1Bh 50h <n>	
27 80 <n>	

The command above sets or cancels pica proportional pitch printing, where <n> is a binary value of either 00h or 01h. If <n> is set to 01h, then pica proportional printing is enabled, and if <n> is set to 00h, then pica proportional printing is disabled. Any other values of <n> with this command will set pica pitch, and the printer will attempt to print <n>. If Panel Pitch Lock mode has been selected, then this command will be ignored.

Special print mode control codes

Select/cancel expanded printing		Both
<ESC>	W	<n>
1Bh	57h	<n>
27	87	<n>

The command above selects or cancels expanded printing, where <n> is a binary or ASCII value from 00h through 01h or "0" through "1". If <n>=00h or "0", then expanded printing is deselected (cancelled), and if <n>=01h or "1", then expanded printing is selected for all printing subsequent to the receipt of this command.

Select one-line expanded printing		Both
<ESC>	<SO>	
1Bh	0Eh	
27	14	
<SO>		
0Eh		
14		

Either of the commands above will select one-line expanded print. There are no parameters. Expanded printing will be performed subsequent to the receipt of this command until any of the following commands is received: <DC4>, <LF>, <ESC> <LF>, <VT>, <FF>, <ESC> <FF>, <ESC> W or <FS> E.

Cancel one-line expanded print		Both
<DC4>		
14h		
20		

The command above cancels the one-line expanded print mode set by <SO> or <ESC> <SO>. There are no parameters.

Select/cancel expanded print			Standard
<FS>	E	<n>	
1Ch	45h	<n>	
28	69	<n>	

The command above sets or cancels expanded printing, where <n> is a binary or ASCII value in the range 00h through 02h or "0" through "2". The effect of this command is shown in the table below:

Value of <n>	Description
00h or "0"	Cancels expanded printing
01h or "1"	Sets double-width printing
02h or "2"	Sets triple-width printing

Select Master print mode			Both
<ESC>	!	<n>	
1Bh	21h	<n>	
27	33	<n>	

The command above selects a "Master print" mode, where <n> is a binary value composed of the addition of the following bit settings:

Bit	Value (dec)	Value (hex)	Function	Effect when bit=1	Effect when bit=0
0	1	01h	Pitch	12cpi	10cpi
1	2	02h	Proportional printing	set	cancel
2	4	04h	Condensed printing	set	cancel
3	8	08h	Emphasized printing	set	cancel
4	16	10h	Double-strike printing	set	cancel
5	32	20h	Double-width printing	set	cancel
6	64	40h	Italic printing	set	cancel
7	128	80h	Underlined printing	set	cancel

Hence, if condensed italic underlined print is required at 12cpi, the values of bits 2, 6, 7 and 0 must be added together. This comes to (in decimal) $4+64+128+1 = 197$, or (in hexadecimal) $04h+40h+80h+01h=C5h$. The master mode is hence a useful way of selecting a number of print parameters simultaneously.

Select print mode		IBM
<ESC>	I	<n>
1Bh	49h	<n>
27	73	<n>

The command above selects the print mode (resident/downloaded font, pitch, print quality), where <n> is a binary value. The print mode selected by different values of <n> is shown in the table below:

<n>	Print mode		
	Font	Quality	Pitch
0	Resident	Draft	Pica
8	Resident	Draft	Elite
16	Resident	Draft	Condensed
2	Resident	LQ	Pica
10	Resident	LQ	Elite
18	Resident	LQ	Condensed
3	Resident	LQ	Proportional
4	Download	Draft	Pica
12	Download	Draft	Elite
20	Download	Draft	Condensed
6	Download	LQ	Pica
14	Download	LQ	Elite
22	Download	LQ	Condensed
7	Download	LQ	Proportional

This command is ignored if Panel Lock mode has been selected.

Select emphasized print mode		Both
<ESC>	E	
1Bh	45h	
27	69	

The command above selects the emphasized print mode. There are no parameters. All characters printed subsequent to receipt of this command will be printed in emphasized mode.

Cancel emphasized print mode		Both
<ESC>	F	
1Bh	46h	
27	70	

The command above cancels the emphasized print mode. There are no parameters. All characters printed subsequent to receipt of this command will be printed in non-emphasized mode (cancelling the effect of the <ESC> E command).

Select double-strike printing		Both
<ESC>	G	
1Bh	47h	
27	71	

The command above will select the double-strike print mode. There are no parameters. Any characters printed subsequent to the receipt of this command will be printed in double-strike mode.

Cancel double-strike printing		Both
<ESC>	H	
1Bh	48h	
27	72	

The command above will cancel the double-strike print mode. There are no parameters. Any characters printed subsequent to the receipt of this command will be printed in non-double-strike print mode (cancelling the effect of the <ESC> G command).

Select/cancel underline			Both
<ESC>	-	<n>	
1Bh	2Dh	<n>	
27	45	<n>	

The command above will select or cancel underlining, where <n> is a binary or ASCII value which may take the values 00h through 01h or "0" through "1". If the value is 00h or "0", then underlining will be cancelled. If <n>=01h or "1", then all printable characters including spaces (but excluding horizontal tabs and IBM block graphic characters) will be underlined.

Select/cancel overline		Both
<ESC>	_	<n>
1Bh	5Fh	<n>
27	95	<n>

The command above will select or cancel overlining, where <n> is a binary or ASCII value which may take the values 00h through 01h or "0" through "1". If the value is 00h or "0", then overlining will be cancelled. If <n>=01h or "1", then all printable characters including spaces (but excluding horizontal tabs) will be overlined.

Select superscript/subscript		Both
<ESC>	S	<n>
1Bh	53h	<n>
27	83	<n>

The command above will select either superscript or subscript printing, where <n> is a binary or ASCII value which may take the values 00h through 01h or "0" through "1". If the value is 00h or "0", superscript printing will be selected, and if <n>=01h or "1", then subscript printing will be selected.

Cancel superscript/subscript		Both
<ESC>	T	
1Bh	54h	
27	84	

The command above will cancel superscript or subscript printing (if either has been selected). There are no parameters. If either superscript or subscript printing has been selected, then printing subsequent to receipt of this command will be in the normal position.

Set/cancel shadow/outline printing		Standard
<ESC>	q	<n>
1Bh	71h	<n>
27	113	<n>

The command above sets or cancels shadow or outline printing, where <n> is a binary value from 00h through 03h. The values of <n> are given in the table below:

Value of <n>	Result
00h	Cancel shadow/outline printing
01h	Set outline printing
02h	Set shadow printing
03h	Set shadow and outline printing

Any other values of <n> are invalid and will be ignored.

Line space control codes

Line feed	Both
<LF>	
0Ah	
10	

The command above advances the paper one line. There are no parameters. If Auto CR has been selected, a carriage return will also be generated on receipt of a Line Feed character. 1/6 inch line spacing will automatically be selected at power-on.

Reverse line feed	Both
<ESC>	<LF>
1Bh	0Ah
27	10

The command above will reverse line-feed the paper one line. There are no parameters. 1/6 inch line spacing is automatically selected at power-on.

Set line spacing to 1/8 inch		Both
<ESC>	0	
1Bh	30h	
27	48	

There are no parameters. The command above sets line spacing to 1/8 inch, where "0" is the ASCII value "0".

Set line spacing to 7/60 or 7/72 inch		Both
<ESC>	1	
1Bh	31h	
27	49	

There are no parameters. The command above sets line spacing to 7/60 inch (in IBM emulation mode, 7/72 inch), where "1" is the ASCII value "1".

Set line spacing to 1/6 inch		
<ESC>	2	Standard
1Bh	32h	
27	50	
<FS>	2	IBM
1Ch	32h	
28	50	

There are no parameters. The command above sets line spacing to 1/6 inch, where "2" is the ASCII value "2".

Set line spacing units			IBM		
<ESC>	[\	<EOT>	<NUL>	<NUL>
<NUL>	<NUL>	<n>			
1Bh	5Bh	5Ch	04h	00h	00h
00h	00h	<n>			
27	91	92	4	0	0
0	0	<n>			

The command above sets the units which will be used for setting the amount of line spacing, where <n> is a binary value representing either 180 (B4h) or 216 (D8h). Line spacing is then defined in terms of either 1/180 or 1/216 inch units. This command only becomes effective after an <ESC>3 or an <ESC>J command has been received.

Set line spacing to n/180 or n/216 Inch			Both
<ESC>	3	<n>	
1Bh	33h	<n>	
27	51	<n>	

The command above allows precise control of line spacing, where <n> is a binary value. Upon receipt of this command, the line spacing will be set to <n>/180 inch (when in IBM mode, <n>/216 inch, rounded to the nearest 1/360 inch).

Set line spacing to n/60 Inch			Standard
<ESC>	A	<n>	
1Bh	41h	<n>	
27	65	<n>	

The command above sets the line spacing in increments of 1/60 inch, where <n> is a binary value. On receipt of this command, line spacing will be set to <n>/60 inch.

Set line spacing to n/72 Inch			IBM
<FS>	A	<n>	
1Ch	41h	<n>	
28	65	<n>	

The command above sets line spacing in increments of 1/72 inch, where <n> represents the number of 1/72 inch increments which will constitute a line feed after the receipt of this command.

Define line spacing (1/72 Inch Increments)			IBM
<ESC>	A	<n>	
1Bh	41h	<n>	
27	65	<n>	

The command above defines line spacing in 1/72 inch increments, where <n> is an optional binary value if it is not equal to zero, <n> defines the line spacing which will be implemented after an <ESC>2 command has been received. If <n> = 0, then the current value of line spacing set by a previous <ESC>A command will remain in force.

Execute <ESC>A definition			IBM
<ESC>	2		
1Bh	32h		
27	50		

The command above executes the line spacing previously defined by the <ESC>A command. There are no parameters. If an <ESC>A sequence has not previously been entered, then line spacing will be set at 1/6th inch. If an <ESC>A sequence has been received prior to this command, then any subsequent line feeds will move the paper by the amount specified by the <ESC>A command.

One-time line feed (In 1/180 Inch Increments)			Both
<ESC>	J	<n>	
1Bh	4Ah	<n>	
27	74	<n>	

The command above causes a precise paper feed, where <n> is a binary value. On receipt of this command, the paper will be fed forward by <n>/180 inch (in IBM mode, <n>/216 inch, rounded to the nearest 1/360 inch). No carriage return will take place, and the current line spacing value will be unaffected.

Reverse one-time line feed (In 1/180 Inch Increments)			Standard
<ESC>	j	<n>	
1Bh	6Ah	<n>	
27	106	<n>	

The command above causes a precise reverse paper feed, where <n> is a binary value. On receipt of this command, the paper will be fed backwards by <n>/180 inch. No carriage return will take place, and the current line spacing value will be unaffected.

Set line spacing to n/360 Inch			Both
<ESC>	+	<n>	
1Bh	2Bh	<n>	
27	43	<n>	
<FS>	3	<n>	
1Ch	33h	<n>	
28	51	<n>	

The command above sets line spacing in 1/360 inch increments, where <n> is a binary value specifying the new line-feed value in 1/360 inch units.

Set vertical print position (In lines)				Both
<ESC>	f	1	<n>	
1Bh	66h	31h	<n>	
27	102	49	<n>	

The command above sets the next vertical print position, where <n> is a binary value specifying the number of lines (at current line pitch setting) down from the current position at which printing will next take place. In the command the binary character 01h can be substituted for the ASCII character "1".

Select forward feed	Standard
<FS>	F
1Ch	46h
28	70

The command above selects forward paper feed. There are no parameters. This is the default setting at power-on. All vertical paper-handling commands will be executed as described.

Select reverse feed	Standard
<FS>	R
1Ch	52h
28	82

The command above selects reverse paper feed. There are no parameters. On receipt of this command, all vertical paper handling commands will be executed in a reverse direction (eg a reverse line feed will become a forward line feed, and a forward line feed will become a reverse line feed). This command is invalid if the ASF has been selected.

Form feed control codes

Form feed	Both
<FF>	
0Ch	
12	

The command above will cause a form feed. There are no parameters. On receipt of this command, the printer will print all data stored in the print buffer, and will move to the top of the next page (as determined by the form length set by <ESC> C or <ESC> C<NUL>. A carriage return (to the left margin) will also take place. If the ASF has been selected, this command functions as a page eject command.

Reverse feed to top of form		Both
<ESC>	<FF>	
1Bh	0Ch	
27	12	

The command above reverses the paper to the top of the form. There are no parameters. On receipt of this command, the paper will be fed backwards to the top of the current page. A carriage return (to the left margin) will also take place. This command is invalid if the ASF has been selected.

Set page length (In inches)				Both
<ESC>	C	<NUL>	<n>	
1Bh	43h	00h	<n>	
27	67	0	<n>	

The command above sets the page length in inches, where <n> is a binary value ($1 \leq \langle n \rangle \leq 22$ in standard mode, $1 \leq \langle n \rangle \leq 255$ in IBM mode) representing the new page length in inches. The bottom margin is reset, and the current line after execution of this command is made the new top of form.

Set page length (In lines)			Both
<ESC>	C	<n>	
1Bh	43h	<n>	
27	67	<n>	

The command above sets the page length in lines, where <n> is a binary value ($1 \leq \langle n \rangle \leq 127$ in standard mode, $1 \leq \langle n \rangle \leq 255$ in IBM mode). The new page length is set according to the current line spacing value. Subsequent changes of the line spacing value will not affect the page length. The bottom margin is reset, and the current line after execution of this command is made the new top of form. This command is invalid if the line spacing is set to 0.

Set top-of-form		IBM
<ESC>	4	
1Bh	34h	
27	52	

The command above sets the top-of-form position at the current paper position. There are no parameters. On receipt of this command, the top-of-form position will be set to the current paper position.

Margins and vertical tab setting control codes

Move to next vertical tab position		Both
<VT>		
0Bh		
11		

The command above moves the paper to the next vertical tab position. There are no parameters. On receipt of this command, the printer prints data stored in the print buffer, and the paper moves to the next vertical tab position or (if there are no more vertical tab positions on the page), to the top of the next page. If no vertical tab positions have been set with the <ESC> B command or if they have been cleared, the paper moves forward by one line.

Set vertical tab positions						Both
<ESC>	B	<n0>	...	<n1>	<NUL>	
1Bh	42h	<n0>	...	<n1>	00h	
27	66	<n0>	...	<n1>	00	

The command above sets vertical tab positions, where the values represented by <n0> to <n1> are binary values giving the vertical tab positions in lines from the top of the page. The values given must be in ascending order. If they are not, the sequence will be terminated. The sequence must end with a <NUL> (ASCII 00h). If no values are given between the <ESC> B and the <NUL>, then all vertical tab positions previously set will be cleared. Printing will start on the (<n>+1th) line in standard mode, and the (<n>th) line in IBM mode.

Select vertical form unit (VFU) channel			Both
<ESC>	/	<m>	
1Bh	2Fh	<m>	
27	47	<m>	

The command above selects a VFU within which all subsequent <VT> commands will be executed, where <m> is a binary value from 0 to 7. Different sets of vertical tabs can be stored in different channels using the <ESC> b command, and selected using this command.

Set VFU vertical tabs						Both
<ESC>	b	<m>	<n0>	...	<n1>	<NUL>
1Bh	62h	<m>	<n0>	...	<n1>	00h
27	98	<m>	<n0>	...	<n1>	0

The command above sets vertical tabs inside a VFU, where <m> is the VFU channel ($0 \leq m \leq 7$) (accessed by the <ESC> / <m> command), and subsequent absolute values (in lines) of vertical tabs (accessed by the <VT> command) are represented by <n0> to <n1>. These values must be given in ascending order, otherwise the command will be terminated. The sequence must end with a <NUL> (00h). If no vertical tab values are given between the channel number and the <NUL>, then all previous vertical tab positions set for that channel will be cleared.

Set relative vertical tab positions				Both
<ESC>	e	1	<n>	
1Bh	65h	31h	<n>	
27	101	49	<n>	

The command above will set relative vertical tab positions, where <n> is a binary value giving the distance in lines between vertical tabs set by this command. The vertical tabs set by this command are subsequently accessed by the <VT> command. All vertical tabs previously set are cleared. Instead of the ASCII "1", the binary 01h character can be used.

Set top margin			Both
<ESC>	c	<n>	
1Bh	63h	<n>	
27	99	<n>	

The command above sets the top margin, where <n> is a binary value which specifies the height of the top margin to the first printed line in lines (at the current line pitch setting). Printing will start on the (<n>+1th) line on the page. Subsequent changes to the line pitch setting will not affect this value.

Set bottom margin			Both
<ESC>	N	<n>	
1Bh	4Eh	<n>	
27	78	<n>	

The command above sets the bottom margin, where <n> is a binary value specifying the bottom margin depth in lines at the current line pitch setting. If the page length is reset (with the <ESC>C or <ESC>C<NUL> commands), the effect of this command will be lost. Subsequent changes to the line pitch setting, however, will not affect the length set by this command.

Cancel top and bottom margins			Both
<ESC>	O		
1Bh	4Fh		
27	79		

The command above cancels the settings for top and bottom margins. There are no parameters.

Set left and right margins				Both
<ESC>	X	<n>	<n>	
1Bh	58h	<n>	<n>	
27	88	<n>	<n>	

The command above sets the left and right margins, where the two values represented by the <n>s are binary numbers used for setting the left and right margins respectively. Margins are set at the current horizontal pitch.

Set left margin			Both
<ESC>	l	<n>	
1Bh	6Ch	<n>	
27	108	<n>	

The command above sets the left margin, where “l” is a lowercase “L” (not “one”), and <n> is a binary value used to set the left margin. The margin is defined in terms of the number of character positions at current pitch. If proportional spacing has been selected, then the character width for pica pitch is used. The left margin may not be closer than two print positions to the right margin, otherwise this command is ignored.

Set right margin			
<ESC>	Q	<n>	Standard
1Bh	51h	<n>	
27	81	<n>	
<FS>	Q	<n>	IBM
1Ch	51h	<n>	
28	81	<n>	

The command above sets the right margin, where <n> is a binary value used to set the right margin in character spaces at the current pitch. If proportional spacing has been selected, then the character width for pica pitch is used.

Horizontal print position control codes

Move print position to the right				IBM
<ESC>	d	<n0>	<n1>	
1Bh	64h	<n0>	<n1>	
27	100	<n0>	<n1>	

The command above moves the current print position to the right, where <n0> and <n1> (low byte first) indicate the amount by which the print position will be moved in 1/120 inch units. If this command would set a print position beyond the right margin, then the print position moves only to the right margin. If underlining or overlining is in effect prior to the receipt of this command, then the skipped space will also be underlined or overlined (cf horizontal tabs).

Carriage return	Both
<CR>	
0Dh	
13	

The command above performs a carriage return. The print head will return to the beginning of the print line. If AUTOLF has been set up with the Memory Switches, a line feed will be performed as will (at the current line spacing).

Set/cancel automatic line feed	IBM
<ESC>	5 <n>
1Bh	35h <n>
27	53 <n>

The command above sets or cancels automatic line feed, where <n> is a binary value of either 00h or 01h. If <n>=01h, then whenever the printer receives a <CR> (0Dh), a line feed will automatically be added by the printer. If <n>=00h, then this function will be cancelled.

Move to next horizontal tab	Both
<HT>	
09h	
9	

The command above moves the print head to the next horizontal tab setting. There are no parameters. If there are no horizontal tabs set on the line following the current print position, this command is ignored. If underlining is on, then skipped print positions are not underlined.

Set/clear horizontal tabs					Both
<ESC>	D	<n0>	...	<n1>	<NUL>
1Bh	44h	<n0>	...	<n1>	00h
27	67	<n0>	...	<n1>	0

The command above sets horizontal tabs, where <n0> and <n1> are binary values representing the new tab positions. If no values are given, all tab stops are cleared. The default tab setting is every eight characters. Tabs are set at the current character pitch. If proportional spacing has been selected, then pica pitch is used for determining the positions of the tabs. In Standard mode, once the tabs have been set, the position of the tabs will remain the same if the character pitch is changed. In the IBM mode, the tab settings will change relative to the new character pitch if the character pitch is changed.

Restore tabs to default settings		IBM
<ESC>	R	
1Bh	52h	
27	82	

The command above restores all tabs (vertical and horizontal) to default settings. There are no parameters. On receipt of this command, all vertical tab settings will be cleared, and all horizontal tabs will be reset to every eighth position, starting at column 9.

Set relative horizontal tab positions				Both
<ESC>	e	0	<n>	
1Bh	65h	30h	<n>	
27	101	48	<n>	

The command above sets horizontal tabs, where <n> is a binary value. On receipt of this command, all horizontal tabs will be cleared, and new ones inserted every <n> characters. These horizontal tabs can be accessed with an <HT> command.

Set horizontal print position			Both
<ESC>	f	0	<n>
1Bh	66h	30h	<n>
27	102	48	<n>

The command above sets the next horizontal print position, where <n> is a binary value. The next horizontal printing will take place <n> character spaces (at current print pitch) from the current horizontal print position.

Set justification mode			Both
<ESC>	a	<n>	
1Bh	61h	<n>	
27	97	<n>	

The command above will set the justification mode in which the printer prints received data, where <n> is a binary or ASCII value in the range 00h (or "0") through 03h (or "3"). The meanings of these values are shown in the table below:

Value	Meaning
00h, "0"	Left justification
01h, "1"	Centering
02h, "2"	Right justification
03h, "3"	Full justification

The default (when the printer is first turned on) is left justification.

Produce character space			Standard
<ESC>	<SP>	<n>	
1Bh	20h	<n>	
27	32	<n>	

The command above produces a space character, where <SP> is the ASCII space character (20h), and <n> is a binary value from 0 through 127 giving the space width in dots. When in draft mode, the dot spacing is 1/120 inch, and when in LQ or SLQ, the dot spacing is 1/180 inch. If in superscript or subscript printing, the dot spacing is the same as above, but if in expanded mode, the resolution is half the above.

Select next horizontal print position (by dot)			Both
<ESC>	\$	<n0>	<n1>
1Bh	24h	<n0>	<n1>
27	36	<n0>	<n1>

The command above will start subsequent printing at a horizontal position determined by dot spacing, where <n0> and <n1> are two binary numbers (low byte first) specifying the number of dots (at 1/60 inch spacing) by which the print head will move to the right from the left margin. If the subsequent print position is beyond the right margin, then printing will start at the left margin.

Move print head			Standard
<ESC>	\	<n0>	<n1>
1Bh	5Ch	<n0>	<n1>
27	92	<n0>	<n1>

The command above moves the print head relative to the last print position, where <n0> and <n1> are two binary numbers (low byte first) specifying the amount (in inches) by which the print head will move from the last print position. When in draft mode, the number represented by the parameters signifies movement in 1/120ths inch, and when in LQ or SLQ mode, movement is carried out in 1/180ths inch. A positive value will move the print head to the right, and a negative value will move it to the left. See "Numerical Representation" for details of how negative values are represented in this way.

Downloaded character control codes

Copy standard ROM font into RAM				
<ESC>	:	<NUL>	<n>	<NUL> Standard
1Bh	3Ah	00h	<n>	00h
27	58	0	<n>	0
<FS>	:	<NUL>	<n>	<NUL> IBM
1Ch	3Ah	00h	<n>	00h
28	58	0	<n>	0

The command above copies the characters from the selected character set with <n>, as shown below, into the download RAM area. <NUL> is the ASCII character 00h. This command is only valid if "DOWNWARD" has been selected in the RAM USAGE menu of the Memory Switch (see Chapter 3 for details). All characters from 20h to FFh are copied. Regardless of the character set, the characters 80h to 9Fh are copied. However, the block characters of the IBM character set (B0h through DFh, F4h and F5h) are copied as space characters.

Binary Value	Selected font	Binary Value	Selected font
00h	TMS ROMN	07h	Letter-Gothic
01h	TW-LIGHT	08h	Blippo
02h	Courier	09h	Orator
03h	Prestige	0Ah	Helvet
04h	Script	0Bh	Optimo
05h	OCR-B	0Ch	Cinema
06h	OCR-A	0Eh	Greek

Define download character(s)					
<ESC> <a1>	& <a2>	<NUL> <n>	<c1> ...	<c2> <n>	<a0> Standard
1Bh <a1>	26h <a2>	00h <n>	<c1> ...	<c2> <n>	<a0>
27 <a1>	38 <a2>	0 <n>	<c1> ...	<c2> <n>	<a0>
<ESC> <a1>	= <a2>	<NUL> <n>	<c1> ...	<c2> <n>	<a0> IBM
1Bh <a1>	3Dh <a2>	00h <n>	<c1> ...	<c2> <n>	<a0>
27 <a1>	61 <a2>	0 <n>	<c1> ...	<c2> <n>	<a0>

The command above enables the definition of “soft” characters to be downloaded. The following rules are observed. <c1> and <c2> are binary values which determine the character range which will be replaced by downloaded data. For instance, if <c1>=20h and <c2>=30h, all characters from 20h through 30h will be overwritten by the downloaded data. If a downloaded character is stored in the area 80h through 9Fh, it can only be printed in the character set #2 mode. It is possible to store downloaded characters in the part of the character set reserved for IBM block graphics (B0h through DFh, F4h and F5h), but these characters can only be printed when the standard character set has been selected.

<a0>, <a1> and <a2> are attribute bytes, setting the starting dot column, printable width (in dots), and ending dot column respectively. The following values must not be exceeded:

	<a1>	<a0>+<a1>+<a2>
Draft	9	12
LQ 10cpi	29	36
LQ 12cpi	23	30
LQ 15cpi	15	24
Proportional	37	42
Draft Super/Subscript	7	12
LQ Super/Subscript	23	36
Proportional Super/Subscript	23	42

The vertical definition of the characters is 16 dots in superscript/subscript modes, and 24 in all others. Each byte therefore represents half of the vertical definition of a character column in superscript/subscript mode, and a third of the vertical definition in other modes. If $\langle n \rangle$ bytes are required for a normal character, the arrangement of these bytes is as follows (where the byte numbers are represented by decimal numbers, starting at 0), and the total width of the character has been defined by the parameter $\langle al \rangle$:

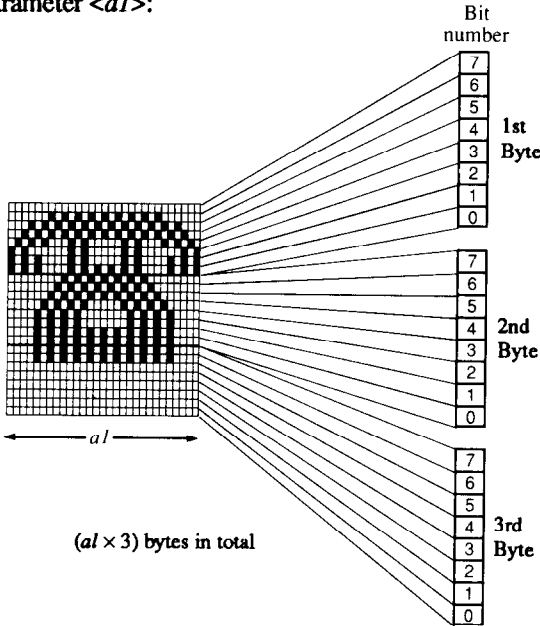

In the case of a superscript/subscript character, the width has also been defined by $\langle al \rangle$, but only two bytes are required per vertical column, so the arrangement is as follows:

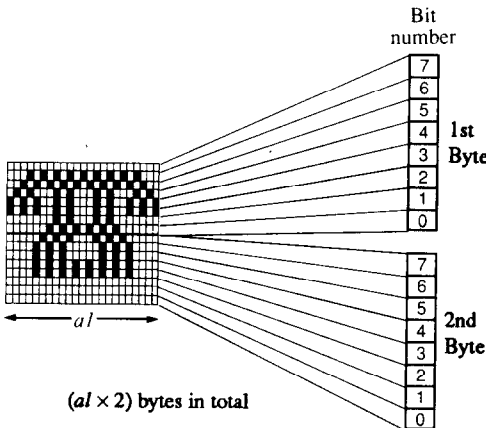

Select download/standard character set			Both
<ESC>	%	<n>	
1Bh	25h	<n>	
27	37	<n>	

The command above selects either the standard or downloaded character set, where <n> is a binary value (00h or 01h) or an ASCII value ("0" or "1"). If <n> equals 00h or "0", the standard character set is selected. This is the default value at power-on. If 01h or "1" has been selected, then the downloaded character set is selected.

Graphics

The following commands relate to the graphical capabilities of the printer (bit image mode). All bit-image printing is carried out as raster graphics (ie data is accepted in blocks, and then printed as adjacent lines of graphics one dot wide).

Select bit Image mode						Both
<ESC>	*	<m>	<n0>	<n1>	<d0>	
...	<dn>					
1Bh	2Ah	<m>	<n0>	<n1>	<d0>	
...	<dn>					
27	42	<m>	<n0>	<n1>	<d0>	
...	<dn>					

The command above selects one of the graphic modes available on the printer and prints graphic data, where <m> is a binary value representing the graphics mode (see table below), and <n0> and <n1> are binary values (low byte first) giving the number of graphic data bytes following (as represented by <d0> ... <dn>). The actual number of data bytes varies according to the graphic mode chosen. In an 8-pin mode, the number of data bytes is equal to the number of graphic columns to be printed, but in a 24-pin mode, the number of data bytes is three times the number of graphic columns to be printed.

[Graphic print modes]

<m>	Mode	Pins	DPI	<m>	Mode	Pins	DPI
0	Single	8	60	32	Single	24	60
1	Double	8	120	33	Double	24	120
2	High-speed double*	8	120	38	CRT III	24	90
3	Quadruple*	8	240	39	Triple	24	180
4,5	CRT I	8	80	40	Hex	24	360
6,7	CRT II	8	90				

* Adjacent dots are not printable in these modes

[Relationship of bit number to dot position]

When the printer is printing bit-image data using 8 pins in standard (non-IBM) mode, the relationship of dots to pins used is as follows:

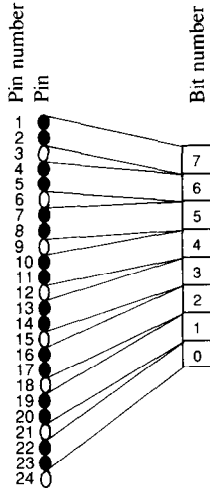

When the printer is printing bit-image data in 24-pin resolution (both in standard and IBM emulation mode), the relationship between the bits set and the dots printed is as follows:

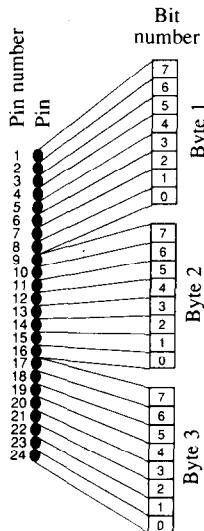

Select bit Image mode			IBM		
<ESC> <d0>	[...	g <dn>	<n0>	<n1>	<m>
1Bh <d0>	5Bh ...	67h <dn>	<n0>	<n1>	<m>
27 <d0>	91 ...	103 <dn>	<n0>	<n1>	<m>

The command above selects the bit image mode for graphical printing, and gives the number of bytes to be printed, where <n0> and <n1> (low byte first) give the number of graphical data bytes represented by <d0> through <dn>, and <m> represents the graphics mode, as represented in the table below:

<m>	Mode	Pins	DPI	<m>	Mode	Pins	DPI
0	Single	8	60	8	Single	24	60
1	Double	8	120	9	Double	24	120
2	High-speed double*	8	120	11	Triple	24	180
3	Quadruple*	8	240	12	Hex	24	360

* Adjacent dots are not printable in these modes

[Relationship of bit number to dot position]

The total number of graphical blocks to be printed is given by the formula $(\langle n0 \rangle + \langle n1 \rangle \times 256) - 1$. When the printer is printing bit-image data in IBM mode, the relationship of bits transmitted to dots printed is as follows:

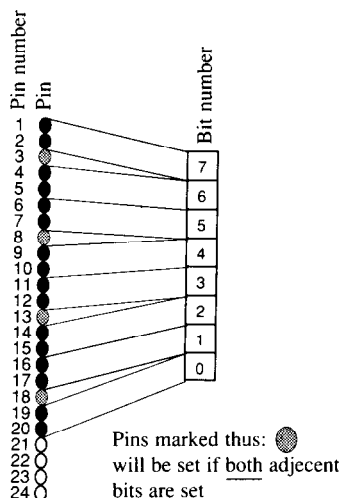

Select 8-dot normal density						Both
<ESC>	K	<n0>	<n1>	<d0>	...	<dn>
1Bh	4Bh	<n0>	<n1>	<d0>	...	<dn>
27	75	<n0>	<n1>	<d0>	...	<dn>

The command above selects 8-dot normal density bit-image printing, where <n0> and <n1> are binary values (low byte first) representing the number of data bytes following the command. The data bytes are represented by <d0> ... <dn>. This command has the same effect as <ESC> * 0.

Select 8-dot double-density						Both
<ESC>	L	<n0>	<n1>	<d0>	...	<dn>
1Bh	4Ch	<n0>	<n1>	<d0>	...	<dn>
27	76	<n0>	<n1>	<d0>	...	<dn>

The command above selects 8-dot double-density bit-image printing, where <n0> and <n1> are binary values (low byte first) representing the number of data bytes following the command. The data bytes are represented by <d0> ... <dn>. This command has the same effect as <ESC> * 1.

Select 8-dot double-speed double-density						Both
<ESC>	Y	<n0>	<n1>	<d0>	...	<dn>
1Bh	59h	<n0>	<n1>	<d0>	...	<dn>
27	89	<n0>	<n1>	<d0>	...	<dn>

The command above selects 8-dot double-speed, double-density bit-image printing, where <n0> and <n1> are binary values (low byte first) representing the number of data bytes following the command. The data bytes are represented by <d0> ... <dn>. This command has the same effect as <ESC> * 2.

Set 8-dot quadruple-density						Both
<ESC>	Z	<n0>	<n1>	<d0>	...	<dn>
1Bh	5Ah	<n0>	<n1>	<d0>	...	<dn>
27	90	<n0>	<n1>	<d0>	...	<dn>

The command above selects 8-dot quadruple-density bit-image printing, where <n0> and <n1> are binary values (low byte first) representing the number of data bytes following the command. The data bytes are represented by <d0> ... <dn>. This command has the same effect as <ESC> * 3.

Set 24-dot hex-density						Both
<FS>	Z	<n0>	<n1>	<d0>	...	<dn>
1Ch	5Ah	<n0>	<n1>	<d0>	...	<dn>
28	90	<n0>	<n1>	<d0>	...	<dn>

The command above selects 24-dot hex-density bit-image printing, where <n0> and <n1> are binary values (low byte first) representing the number of data bytes following the command. The data bytes are represented by <d0> ... <dn>. This command has the same affect as <ESC> * 40.

Redefine bit-Image mode				Both
<ESC>	?	<m0>	<m1>	
1Bh	3Fh	<m0>	<m1>	
27	63	<m0>	<m1>	

The command above redefines a bit-image mode to another mode, where <m0> is the mode to be redefined. This may take the ASCII values "K", "L", "Y" or "Z". <m1> is a binary value representing the mode to which <m0> is redefined, being a value used after the <ESC> * command (0 through 7, 32, 33 or 38 through 40). If any of the modes represented by <m0> are subsequently selected, bit-image printing will now take place in the mode as defined by <m1>.

Miscellaneous codes

The following commands do not relate specifically to graphics, but have more general applications:

Set MSB to 1		Both
<ESC>	>	
1Bh	3Eh	
27	62	

The command above sets the MSB to 1. There are no parameters. On receipt of this command, the most significant bit (MSB) of subsequent data will always be set to 1.

Set MSB to 0		
<ESC>	=	Standard
1Bh	3Dh	
27	61	
<FS>	=	IBM
1Ch	3Dh	
28	61	

The command above sets the MSB to 0. There are no parameters. On receipt of this command, the most significant bit (MSB) of subsequent data will always be set to 0.

Cancel MSB control		Both
<ESC>	#	
1Bh	23h	
27	35	

The command above cancels software control of the MSB. There are no parameters. On receipt of this command, software control of the most significant bit (MSB) by the <ESC>, <ESC>= (standard) or <FS>= (IBM) commands, will be cancelled.

Select zero style			Both
<ESC>	~	<n>	
1Bh	7Eh	<n>	
27	126	<n>	

The command above selects the style in which zeroes will subsequently be printed, where <n> is either a binary value of 00h or 01h or an ASCII value of "0" or "1". If <n> is 00h or "0", then "normal" (non-slashed) zeroes will be printed, but if it is 01h or "1", then the "computer-style" (slashed) zero style will be printed (this overrides the Memory Switch setting, in Chapter 3).

Backspace	Both
<BS>	
08h	
8	

The command above moves the print head back one position. There are no parameters. This command moves the print head back one position (at current spacing) to the left. If proportional spacing has been selected, the print head will move back by a distance equal to the width of the last character printed. It does not delete the last character.

Cancel last character	Both
	
7Fh	
127	

The command above deletes the last character transmitted to the printer. There are no parameters. This code is effectively a destructive backspace.

Cancel last line	Both
<CAN>	
18h	
24	

The command above deletes the last line transmitted to the printer. There are no parameters. The last line transmitted to the printer will be erased from the printer's buffer.

Set printer off-line	Standard
<DC3>	
13h	
19	

The command above sets the printer off-line. There are no parameters. This command is not equivalent to pressing the  button on the front panel when the printer is on-line, as after the <DC3> command has been received, the printer will ignore any data transmitted to it, except for the <DC1> command (below).

Set printer on line	Both
<DC1>	
11h	
17	

The command above sets the printer on-line after a <DC3> command (above). There are no parameters.

Deselect printer (10" carriage model only)	IBM
<ESC>	Q \$
1Bh	51h 24h
27	81 36

The command above deselects the printer. There are no parameters. This command will deselect the printer, forcing it to disregard all data and command codes until a <DC1> (11h) command is received to put the printer back on-line. This command applies only to the model of printer equipped with a 10" carriage.

Deselect printer (15" carriage model only)	IBM
<ESC>	Q #
1Bh	51h 23h
27	81 35

The command above deselects the printer. There are no parameters. This command will deselect the printer, forcing it to disregard all data and command codes until a <DC1> (11h) command is received to put the printer back on-line. This command applies only to the model of printer equipped with a 15" carriage.

Stop printing	IBM
<ESC>	j
1Bh	6A
27	106

The command above forces an off-line status. There are no parameters. The printer goes off-line, and the contents of the buffer are printed. This command differs from the two previous commands (Deselect printer) in that when this command has been received, the parallel interface SELECT signal goes low, and the BUSY signal goes high (ie no data can be received from the computer). It is necessary to press the  button to reset the printer.

Sound buzzer	Both
<BEL>	
07h	
7	

The command above sounds the printer's buzzer. There are no parameters.

Disable paper-out detection	Both
<ESC>	8
1Bh	38h
27	56

The command above disables the printer's paper-out detection. There are no parameters. This overrides the setting made by the Memory Switch settings (Chapter 3).

Enable paper-out detection	Both
<ESC>	9
1Bh	39h
27	57

The command above enables the printer's paper-out detection. There are no parameters. This overrides the setting made by the Memory Switch settings (Chapter 3).

Enable/disable bidirectional printing	Both	
<ESC>	U	<n>
1Bh	55h	<n>
27	85	<n>

The command above enables or disables bidirectional printing, where <n> is a binary value of either 00h or 01h or an ASCII value of either "0" or "1". If <n> is set to 00h or "0", then bidirectional printing will be performed, and if it is 01h or "1", then unidirectional printing will be performed subsequent to the receipt of this command. If the Memory Switch setting has been made for bidirectional printing, this command will be ignored.

Enable unidirectional printing for one line only		Both
<ESC>	<	
1Bh	3Ch	
27	60	

The command above enables unidirectional printing for one line only. There are no parameters. Printing will be performed from left-to-right for the current line only.

Enable/disable quiet mode		Both
<ESC>	s	<n>
1Bh	73h	<n>
27	115	<n>

The command above enables or disables quiet mode, where <n> is a binary value of either 00h or 01h or an ASCII value of either "0" or "1". If <n> is set to 00h or "0", then quiet mode is disabled, and if <n> is set to 01h or "1", then quiet mode is enabled. This command overrides the Memory Switch settings or the setting made from the front panel. Quiet mode means that each character is printed in two passes of the print head.

Enable/disable large character printing		Both
<ESC>	h	<n>
1Bh	68h	<n>
27	104	<n>

The command above enlarges characters, or cancels such enlargement, where <n> is a binary value of 00h through 02h or an ASCII value of "0" through "2". If <n> is set to 00h or "0", then any character enlargement is cancelled. If <n> is set to 01h or "1", then characters are printed at double height and width. If <n> is set to 02h or "2", then characters are printed at quadruple height and width. It is the user's responsibility to alter the line pitch so that it is in accordance with the new character height, and to produce a line feed at the new pitch in order to leave sufficient space for the new characters. If there are different sizes of print on the same line, the printing will be aligned along the top of the characters. Any previous commands for enlargement (vertical or horizontal) of characters will be cancelled by this command.

Enable/disable double-height mode			
<ESC>	w	<n>	Both
1Bh	77h	<n>	
27	119	<n>	
<FS>	V	<n>	Standard
1Ch	56h	<n>	
28	86	<n>	

The command above enables or disables double-height printing, where <n> is a binary value of either 00h or 01h or an ASCII value of either "0" or "1". If <n> is set to 00h or "0", then double-height printing is cancelled. If <n> is set to 01h or "1", then double-height printing is enabled. The character width is unaffected. It is the user's responsibility to alter the line pitch so that it is in accordance with the new character height, and to produce a line feed at the new pitch in order to leave sufficient space for the new characters. If there are different sizes of print on the same line, the printing will be aligned along the bottom of the normal-sized characters. Any previous commands for vertical enlargement of characters will be cancelled by this command.

Select character height, width, line spacing					Both
<ESC>	[@	<n0>	<n1>	<NUL>
<NUL>	<n2>	<n3>			
1Bh	5Bh	40h	<n0>	<n1>	00h
00h	<n2>	<n3>			
27	91	64	<n0>	<n1>	0
0	<n2>	<n3>			

The command above is used to control character height, width and line spacing, where <n0> and <n1> (low byte first) are used to supply the number of subsequent data bytes (1 or 2). The effect of the two data bytes (<n2> and <n3>) is determined as follows:

<n2>	
1	Single-height characters
2	Double-height characters
16	Single line feed
17	Single line feed, single-height characters
18	Single line feed, double-height characters
32	Double line feed
33	Double line feed, single-height characters
34	Double line feed, double-height characters
Any other values	No effect
<n3>	
1	Single-width characters
2	Double-width characters
Any other values	No effect

Any superscript/subscript or condensed mode print settings previously selected will be cancelled, but if double-height printing is cancelled, the printer will return to superscript/subscript or condensed mode printing, if these were selected previously. Any previous commands for vertical character enlargement are cancelled by this command. If double-height and normal-sized characters are printed in the same line, then the printing will be aligned along the bottom of the normal-sized characters.

Set/cancel immediate mode			Both
<ESC>	i	<n>	
1Bh	69h	<n>	
27	105	<n>	

The command above selects or cancels the “immediate” print mode, where **<n>** is a binary value of either 00h or 01h or an ASCII value of either “0” or “1”. If **<n>** is set to 00h or “0”, then immediate printing is cancelled. If **<n>** is set to 01h or “1”, then immediate printing is enabled. In immediate print mode, each character is sent straight to the print head as it is received from the host computer (unbuffered), and the paper moves up so that it is possible to read what is on the paper, similar to a typewriter.

Reset		
<ESC>	@	Both
1Bh	40h	
27	64	
<FS>	@	Standard
1Ch	40h	
28	64	

The command above resets the printer. There are no parameters. On receipt of this command, the buffer is cleared, and all settings (with the following exceptions) are restored to their power-up values.

- ASF settings made with the <ESC> EM command
- Panel mode settings

ASF (Automatic Sheet Feeder) control			Both
<ESC>		<n>	
1Bh	19h	<n>	
27	25	<n>	

The command above controls the operation of the ASF, where is the ASCII code 19h, and <n> may take the binary values 00h or 04h or the ASCII values "R" or "T". The effect of these values is summarized below:

Value	Effect
00h	Select manual mode
04h	Select auto mode
"R"	Eject paper
"T"	Set top print position. This parameter must be followed by another binary value (>1) signifying the distance (in 1/6 inch units) at which printing should start below the top of the paper.

These commands will be ignored if the ASF has not been selected.

Repeated data sequence					Both
<ESC>	V	<n>	<d0>	...	<dn>
<ESC>	V	<NUL>			
1Bh	56h	<n>	<d0>	...	<dn>
1Bh	56h	00h			
27	86	<n>	<d0>	...	<dn>
27	86	0			

The command above delimits data which will be repeated, where <n> is a binary value (0 thru 255) giving the number of times that the data bytes represented by <d0> ... <dn> will be repeated. The sequence is terminated by the <ESC> V <NUL> (<NUL>=00h) sequence. It is possible to nest this sequence (up to five levels).

NOTE

Since repeated data is stored in the input buffer (capacity 2k bytes), the total amount of repeated data cannot exceed this amount.

ASCII command sequences

The command above sequences are not preceded by a <ESC> or <FS> character, but instead are preceded by double parentheses, thus "(("". They apply equally to both the standard and the IBM emulation modes. They are given below:

Select font					Both
((F))	<n>
28h	28h	46h	29h	29h	<n>
40	40	70	41	41	<n>

The command above selects a font, where <n> is an ASCII value which may take the following values:

<n>	Effect	<n>	Effect
"0"	TMS ROMN	"5"	OCR-B
"1"	TW-LIGHT	"6"	OCR-A
"2"	Courier	"7"	Letter-Gothic
"3"	Prestige	"8"	Blippo
"4"	Script	"9"	Draft

Select/cancel Italic print					Both
((I))	<n>
28h	28h	49h	29h	29h	<n>
40	40	73	41	41	<n>

The command above selects or cancels italic printing, where <n> is an ASCII value which may be either "1" or "0". Any other values will be ignored. If <n> = "1" then italic printing is enabled, and if <n> = "0", then italic printing is cancelled.

Select/cancel bold print					Both
((B))	<n>
28h	28h	42h	29h	29h	<n>
40	40	66	41	41	<n>

The command above selects or cancels bold printing, where <n> is an ASCII value which may be either "1" or "0". Any other values will be ignored. If <n> = "1" then bold printing is enabled, and if <n> = "0", then bold printing is cancelled.

Select/cancel expanded print					Both
((S))	<n>
28h	28h	53h	29h	29h	<n>
40	40	83	41	41	<n>

The command above selects or cancels expanded printing, where <n> is an ASCII value from "0" through "3". The effect of <n> is given in the table below:

<n>	Effect	
	Width	Height
"0"	Normal	Normal
"1"	Double	Normal
"2"	Normal	Double
"3"	Double	Double

Select color printing (with color option only)					Both
((C))	<n>
28h	28h	43h	29h	29h	<n>
40	40	67	41	41	<n>

The command above selects the color to be printed when the color option is fitted, where <n> is an ASCII value from "0" through "6". The color selected by <n> is shown in the table below:

<n>	Color
"0"	Black
"1"	Red
"2"	Blue
"3"	Violet
"4"	Yellow
"5"	Orange
"6"	Green

Control ASF				
((<n>))
28h	28h	<n>	29h	29h
40	40	<n>	41	41

The command above controls the ASF (Automatic Sheet Feeder), where <n> is an ASCII parameter which can take the values "0", "4", "R" or "T". This command has exactly the same function as the ESC command.

MEMO

Chapter 5

DIP SWITCHES

The bank of DIP switches inside the printer (see illustration below) is used for various functions. All switches are set ON when the printer leaves the factory.

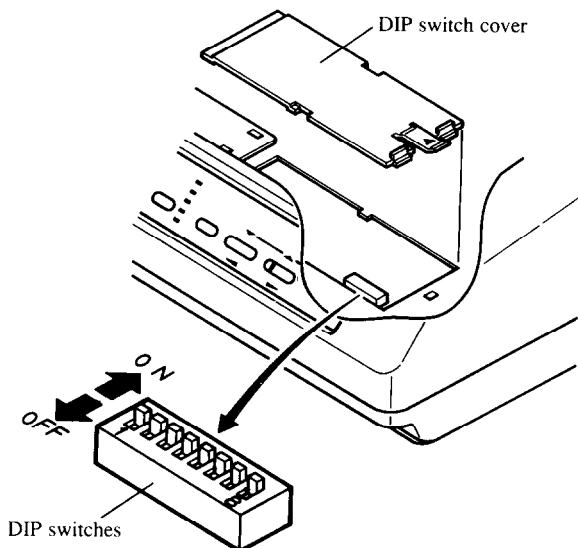

Access the switches by removing the top cover, and then sliding the black switch cover to the left and then pulling up, using the tab at the right, as shown in the illustration above.

The functions of the switches are shown in the table below:

Switch	Function	ON	OFF
1,2	Emulation and character set	See table below	
3	Page length	11 inches	12 inches
4-7	International character set	See table below	
8	Not used	Leave ON	

NOTE

Any changes to the DIP switch settings must be made with the power to the printer turned OFF.

Switches 1 and 2 are used to determine the emulation mode (standard or IBM) of the printer, and also to determine the character set to be used.

Switch		Emulation	Character Set
1	2		
ON	ON	Standard	STD #1
ON	OFF	Standard	IBM #2
OFF	ON	IBM	IBM #2
OFF	OFF	IBM	IBM #1

Switches 4 through 7 are used to select the International character set, as shown in the table below:

Switch				International Character Set
4	5	6	7	
ON	ON	ON	ON	USA
OFF	ON	ON	ON	France
ON	OFF	ON	ON	Germany
OFF	OFF	ON	ON	England
ON	ON	OFF	ON	Denmark I
OFF	ON	OFF	ON	Sweden
ON	OFF	OFF	ON	Italy
OFF	OFF	OFF	ON	Spain I
ON	ON	ON	OFF	Japan
OFF	ON	ON	OFF	Norway
ON	OFF	ON	OFF	Denmark II
OFF	OFF	ON	OFF	Spain II
ON	ON	OFF	OFF	Latin America
OFF	ON	OFF	OFF	Denmark/Norway
ON	OFF	OFF	OFF	Not used
OFF	OFF	OFF	OFF	Not used

Chapter 6 TROUBLESHOOTING AND MAINTENANCE

The following section on troubleshooting and maintenance is intended only as a brief guide to these functions. Remember that your printer is a highly sophisticated electronic device, which also contains high voltages inside. For that reason, only carry out those operations described in this section.

CAUTION

Any attempt to carry out operations other than those described here may result in electric shock and/or damage to the printer. When carrying out any repairs or maintenance, always follow the instructions carefully.
--

TROUBLESHOOTING

Your printer is a reliable piece of precision machinery, which should not cause you any trouble, provided it is used and treated sensibly. However, the few elementary tips below should avoid you having to make unnecessary service calls. The following table gives you ideas on where to look in this section if you experience faults:

Region of fault	Description
Power supply	Power is not being supplied to the printer
Printing	The printer does not print, or stops printing
	The print is faint or uneven
	Dots are missing in characters or graphics
	While using application software, fonts or characters cannot be printed
	The printout is not what is expected when running a program
Paper feeding	Single sheets do not feed properly (without ASF)
	Continuous paper does not feed properly with the tractor feed
	The ASF is not operating or is not feeding paper properly
	Paper park (switching between continuous paper and cut sheets) is not working properly
	The short tear-off function does not work
	Text is being printed all on one line, or with extra blank lines
	Page length and margin settings are not what is expected.

Remember - it is better not to attempt operations or repairs above your level of competence. Otherwise, you run the risk of damaging the printer.

Power supply

If the POWER indicator does not illuminate, check the following:

Check	Possible remedy
Is the power cable properly plugged into the electrical outlet?	Turn off the printer, ensure the power cable is securely connected, and then turn the printer back on.
Is power being supplied to the outlet?	Turn off the printer, unplug it, and try with another appliance to determine if electricity is being supplied to that outlet.
Is the printer voltage correct?	Check the bottom panel of your printer to ensure that the outlet voltage corresponds to the voltage required by the printer. If they do not match, DO NOT try to operate the printer. Contact your supplier.

Printing

If your printer does not print, or suddenly stops printing, check the following:

Check	Possible remedy
Is the interface cable connected securely?	Check both ends of the cable - printer and computer to make sure that the connector is firmly in position.
Is the ON LINE indicator illuminated?	If it is not, press the  button to set the printer on-line.
Is the PAPER indicator illuminated?	If it is, the paper has run out. Load more paper.
Is the paper caught up internally?	Turn off the power, remove the jammed paper, replace, turn on the printer, and continue printing. Make sure that the leading edge of the paper is smooth and uncreased.
Is the ribbon caught up around the print head?	Turn off the power, remove the ribbon, retension it, and replace it. This problem occurs most frequently with a worn ribbon, so you may need to replace the ribbon.
Is the software you are using properly installed for your printer?	Check the installation settings in your software, and re-install if necessary.
Can the printer perform self-test operations?	Turn the printer off, and turn it on again, holding down one of the buttons to perform a self-test. If these do not work, contact your dealer.

If the print is faint, or uneven, check the following:

Check	Possible remedy
Is the ribbon properly installed?	Check and reinstall if necessary.
Is the ribbon worn out?	The ribbon has a long life, but eventually will need replacing. Fit a new ribbon cartridge if necessary.

If dots are missing in the printing, check the following:

Check	Possible remedy
Are dots missing at random in the printing?	The ribbon has become slack, causing it to get caught up. Stop printing, remove the ribbon cartridge, retention and replace it.
Is a line of dots missing consistently throughout the printing?	The print head is damaged. Stop printing, and contact your supplier for a new print head.

If your application software cannot print the fonts or characters selected, check the following:



Check	Possible remedy
Is your application software properly installed?	Check the software installation, and re-install the software if necessary.
Are fonts not being selected properly?	Check the software installation, and insert the commands necessary for font changes into the software.
Are characters other than those expected being printed?	Either you are using the wrong International Character Set (reset with DIP switches or software commands), or you have the wrong character set selected (for example if characters other than IBM block graphic characters are being printed). Correct this with DIP switches or the appropriate software sequences.

If the printout is not what is expected:



Check	Possible remedy
Is the printer installed correctly?	Your software may think that it is driving a different emulation to the one actually set. Check the DIP switch settings to make sure you have the right emulation.
Is the printer not printing anything that you are expecting?	Use the Hex Dump mode to analyze the output from the computer to the printer. This will enable you to determine that the right escape sequences, etc are being transmitted.

Paper feeding

If cut sheet paper (without the ASF) is not feeding smoothly, check the following:

Check	Possible remedy
Is the paper release lever pushed back (to the  position)?	Set the release lever to the  position.
Is the paper guide in place and vertical?	The paper guide should be in place vertically for cut sheets to feed smoothly.
Are the left and right guides too close together?	If the left and right guides are too close together, the paper will not feed smoothly. Move them a little further apart to allow the paper to feed freely.
Is the ASF selected with the Memory Switch settings?	If it is, then deselect it.
Are you trying to feed paper using the front panel buttons while the ON LINE indicator is illuminated?	You can only feed paper in this way when the printer is off-line. Set the printer off-line and then feed paper.
Is the paper too thick?	There are limits to the thickness of paper that can be fed in this way. Try with thinner paper.

If fanfold (continuous) paper is not being fed correctly using the tractor feed, check the following:



Check	Possible remedy
Is the paper lever pushed to the  position?	Make sure the release lever is pushed to the  position.
Is the paper guide in the vertical position?	When using the tractor feed, the paper guide should be horizontal.
Are the holes on each side of the paper aligned with regard to each other in the sprockets?	If the two sides of the paper are out of alignment, realign them so that the sprocket holes match up.
Are the sprockets too close or too far apart?	Misalignment of the sprockets, making the paper too loose or too tight, will prevent a smooth paper feed.
Are the sprockets locked in position and the covers closed?	Correct this if necessary.
Is the paper feeding freely into the printer?	The paper should not be too far from the printer (less than 1 meter/ 3 feet), and there should be no cables or other obstacles obstructing its path. The paper should also be feeding straight into the printer, and an angled feed may cause jams and blockages.

Check	Possible remedy
Are you trying to feed paper using the front panel buttons while the ON LINE indicator is illuminated?	You can only feed paper in this way when the printer is off-line. Set the printer off-line and then feed paper.
Is the paper too thick?	There are limits to the thickness of paper that can be fed in this way (one top copy and three NCR copies). Try with thinner paper.

If the ASF is not operating or is not feeding paper correctly, check the following:

Check	Possible remedy
Has the ASF option been selected using the Memory Switch functions?	Select this option
Is the release lever set to the  position?	The release lever should be set to the single-sheet position.
Is the ASF correctly mounted?	Make sure that the ASF is properly seated on the printer.
Is paper caught up near the print head?	Stop printing, remove the jammed sheet (you may have to remove the ASF for this), and continue.
Are the left and right guides too close together?	If the left and right guides are too close together, the paper will not feed smoothly. Move them a little further apart to allow the paper to feed freely.
Is there too much paper in the paper feed hopper or stacker?	The ASF's paper feed hopper and stacker can hold 120 sheets each. Make sure that there is no more paper than this in either the hopper or stacker.
Was the paper fanned before being fed into the ASF?	If this is not done, paper jams may occur. Remove the stack of paper from the ASF and fan it before reinserting.
Has the paper been used already or is it creased?	Only new, uncreased paper should be used with the ASF.
Are you trying to feed paper using the front panel buttons while the ON LINE indicator is illuminated?	You can only feed paper in this way when the printer is off-line. Set the printer off-line and then feed paper.
Is the paper too thick or too thin?	There are limits to the thickness of paper that can be fed in this way. Try with different paper.

If the paper park facility does not appear to be working correctly, check the following:

Check	Possible remedy
Is the paper release lever in the  position?	The paper release lever must be set to the  position after the fanfold paper has been parked.
Has the fanfold paper been properly parked?	Make sure that the PAPER indicator comes on after the fanfold paper has been parked.

If the short tear-off function does not appear to be working properly, check:

Check	Possible remedy
Has printing ended in the middle of a page?	Either send a <FF> or enough <LF> commands to eject the page.

If text is being printed all on one line, or with extra blank lines, check the following:

Check	Possible remedy
Is the text all on the same line?	Carriage returns are not being expanded to <CR> + <LF> pairs. Check the Memory Switch setting and correct.
Is text being printed with extra blank lines?	Two line feeds are being printed. Either make your software print just a carriage return or (if this is not possible), set the AUTO LF to OFF using the Memory Switch menus.

If the page length and margins are not what is expected, check the following:

Check	Possible remedy
Is the printing starting too high or too low on the page?	Use the Micro Feed facility to adjust the print position relative to the page.
Does the printer's page length not match the physical page length?	Use the Memory Switch settings, or the DIP switch to set up the correct page length, or use software commands to do it.
Is the Skip-over perforation facility not working?	Make sure this is set with the Memory Switch menus. If the skip occurs in the wrong place, make sure the page length is properly set, and that the top of the print position is about two lines down from the top of the paper.

EVERYDAY MAINTENANCE

Essentially, your printer is a robust piece of equipment, but should be treated with a modicum of care in order to avoid malfunctions. For example:

- Keep your printer in a “comfortable” environment. Roughly speaking, if you are comfortable, then the environment is suitable for your printer, too (see Chapter 1).
- Do not subject the printer to physical shocks or excessive vibration.
- Avoid over-dusty environments. Dust is the enemy of all precision mechanical devices. If you have to use the printer in such an situation, you might like to consider the use of an acoustic hood, whose primary function is to reduce the printer’s noise, but can also act as a barrier against dust. Consult your supplier for details of a suitable model.
- To clean the exterior of the printer, use a barely damp cloth (use either water with a little detergent or a little alcohol), but do not allow any liquid to fall inside the printer.
- The interior of the printer may be cleaned with a small vacuum cleaner or a compressed-air aerosol (sold for this purpose). When performing this operation, be sure not to bend or damage any cable connections or electronic components.

ADJUSTING THE PRINTING GAP

The distance between the print head and the platen can be adjusted to accommodate different paper thicknesses. To make this adjustment, remove the top cover. The adjustment lever is located near the left end of the paper bail. Pulling the adjustment lever towards you widens the gap; pushing it away from you narrows the gap.

There are four positions; you can feel the lever clicking into each position. The first position (narrowest gap) is the one most commonly used for single sheets of paper. Try different positions until you get the best printing results.

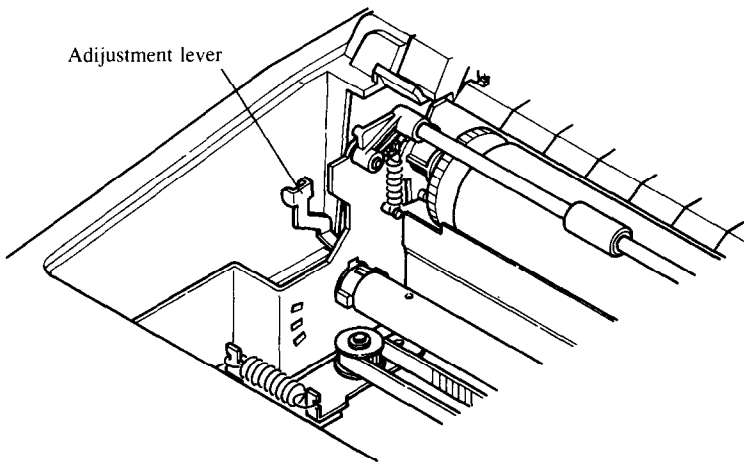

RIBBON REPLACEMENT

The ribbons used by your printer are endless-loop ribbons in which the ribbon is recycled. When the print quality becomes too faint, you will need to replace the ribbon. Use only ribbons recommended for use with the printer (your supplier will be able to advise you).

- 1 To remove the old ribbon from the printer, first turn off the power.
- 2 Remove the top cover, and hold the ribbon by the two lugs on each side. Push in the two lugs slightly, and pull upwards to remove the ribbon.

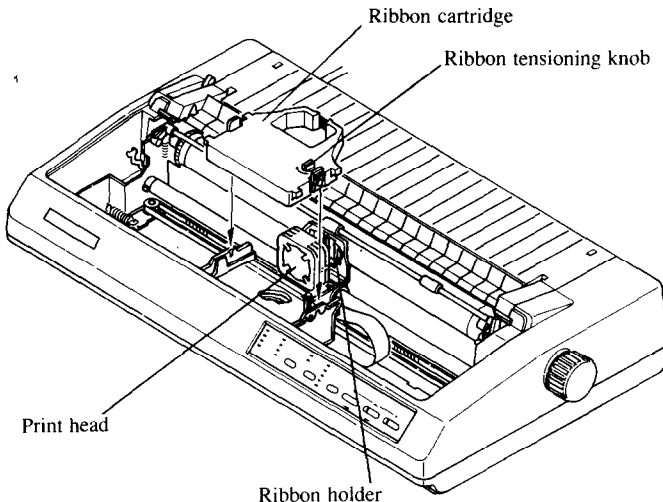

- 3 Take the new ribbon and tension it by turning the knob on the top of the ribbon cartridge clockwise.
- 4 Now insert the ribbon cartridge into the holder gripping it by the lugs, and turning the knob slightly clockwise if necessary. Make sure that the ribbon goes between the print head and the platen guard (see illustration below).

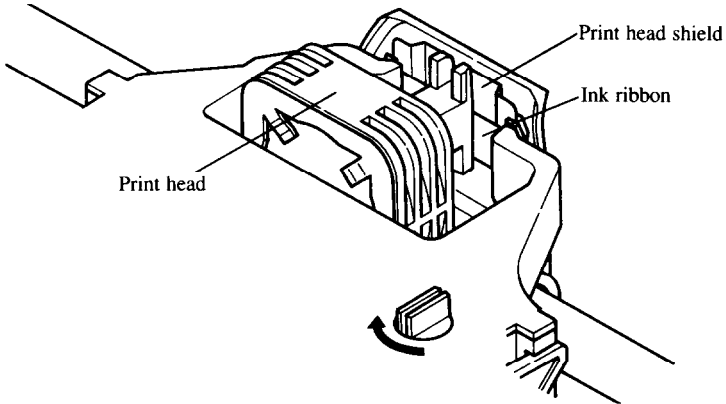

- 5 Now replace the top cover and turn on the printer. You are now ready to start reusing the printer.

REPLACING THE PRINT HEAD

This is not a job which you will need to do very often. The print head has been designed to give a life of about 200 million dots. In normal everyday use, this will mean years of life. However, if the print quality is faint, even after you have changed the ribbon, the print head will need replacement.

Only use a replacement print head as recommended by your supplier.

NOTE

This is a fairly tricky operation. Read the instructions below carefully before attempting it. If you are in any doubt as to your competence to perform it, call in the experts before you start.

- 1 Turn OFF the printer, and remove the power cable.
- 2 If the printer has been in operation immediately before this operation, the print head will be hot.

NOTE

Allow time for the print head to cool before attempting to work on it.

- 3 Open the top cover.
- 4 Remove the ribbon cartridge (as described above)
- 5 Using a Phillips-type screwdriver, carefully unscrew the two bolts securing the print head to the print head assembly (see the illustration below).
- 6 Pull the print head firmly upwards, releasing the print head card edge connectors from the connector mounted on the chassis.
- 7 Remove the retaining screws and washers from the print head assembly. Put them on one side.
- 8 Take the new print head, and locate it in position, making sure that the card edge connections fit securely into the chassis connector.

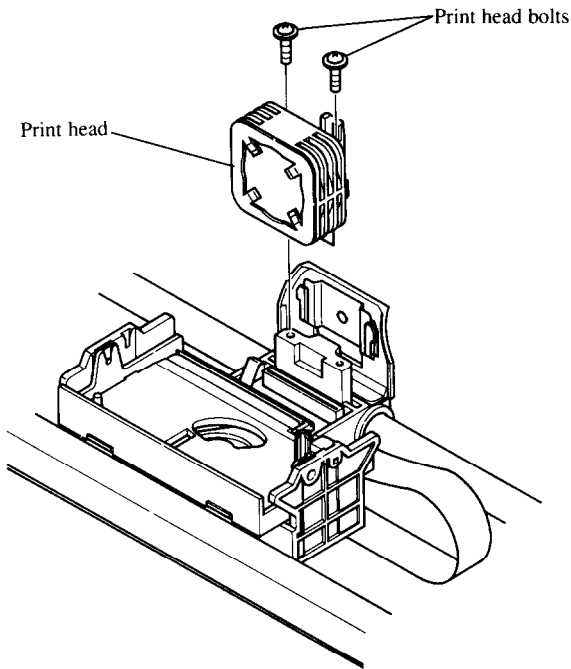

NOTE

DO NOT apply excessive force, as this may result in damage to the print head.

- 9 Fasten down the new print head using the retaining washers and screws. Do not apply excessive force when tightening the screws, as this may strip the thread, but ensure that the print head is firmly secured.
- 10 Replace the ribbon cartridge.
- 11 Replace the top cover.
- 12 Re-insert the power cable and re-apply power. Your printer may now be used. You may like to check the print quality using one of the test print procedures (see below).

Text test mode

In this mode, the printer will print the Memory Switch menus and options. This mode is accessed by turning on the printer at the same time as holding down the **SET/PARK/EJECT** button.

The resulting printout will be similar to the example below:

*** MEMORY SWITCH TREE ***

```

MAIN MENU  PRINT CURRENT SET
|
|-----INSTALL MENU-----
|
|-----COMMAND MENU-----
|
|-----RAM USAGE-----
|
|-----QUIET MODE-----
|
|-----GRAPHICS DIRECTION-----
|
|-----AUTO ON-LINE-----
|
|-----FONT MENU-----
|
|-----ZERO STYLE-----
|
|-----SLQ/LQ FONT-----
|
|-----PRINT MENU-----
|
|-----PRINT QUALITY-----
|
|-----PRINT PITCH-----
|
|-----CONDENSED PRINT-----
|
|-----ITALIC PRINT-----
|
|-----DRAFT-12-----
|
|-----PAPER MENU-----
|
|-----OPTION ASF-----
|
|-----AUTO LOADING-----
|
|-----AUTO LOADING (ASF)-----
|
|-----PAPER-OUT DETECTOR-----
|
|-----FORMS MENU-----
|
|-----SHORT TEAR OFF-----
|
|-----SKIP OVER PERFORATION-----
|
|-----AUTO LF-----
|
|-----AUTO CR-----
|
|-----LINES PER INCH-----
|
|-----PAGE LENGTH (INCH)-----
|
|-----FACTORY SET-----

```

RAM USAGE : BUFFER / DOWNLOAD / 1LINEBUFFER

QUIET MODE : OFF / ON

GRAPHICS DIRECTION : BI / UNI

AUTO ON-LINE : OFF / ON

ZERO STYLE : NORMAL / SLASHED

SLQ/LQ FONT : TNS ROMN(SLQ) /TW-LIGHT(SLQ)
 COURIER /PRESTIGE /ORATOR /SCRIPT
 ELIPPO /LETTER-G /TNS ROMN /TW-LIGHT
 HELVET /OPTIMO /CINEMA /CODE 39
 OCR-A /OCR-B /GREEK /OPTION

PRINT QUALITY : SUPER LQ,LQ / DRAFT

PRINT PITCH : 10CPI / 12CPI / 15CPI / PROP

CONDENSED PRINT : OFF / ON

ITALIC PRINT : OFF / ON

DRAFT-12 : HI-SPEED / HI-DENSITY

OPTION ASF : OFF / ON

AUTO LOADING : 1 / 2 / 3 / 4 / 5 / 6 (6LPI)

AUTO LOADING (ASF) : 1 / 2 / 3 / 4 / 5 / 6 (6LPI)

PAPER-OUT DETECTOR : OFF / ON

SHORT TEAR OFF : OFF / ON

SKIP OVER PERFORATION : OFF / ON

AUTO LF : OFF / ON

AUTO CR : OFF / ON

LINES PER INCH : 3LPI / 4LPI / 6LPI / 8LPI

PAGE LENGTH (INCH) : DIP-SW / 3 / 3.5 / 4 / 5.5
 6 / 7 / 8 / 8.5 / 11.7 / 14

Hexadecimal dump mode

In this mode, all received data will be printed in a hexadecimal dump format, rather than the control codes being acted on as command codes.

This mode is accessed by turning on the printer, while simultaneously holding down the **SET/PARK/EJECT** and **PAPER FEED** keys. To turn off the mode, it is necessary to turn off the printer completely.

The printout will be similar to that produced by a MS-DOS DEBUG Display command, ie the hexadecimal values of the bytes received will be given in rows of 16, divided into two blocks of eight. "Unprintable" characters, ie control codes from 00h through 1Fh and 7Fh through FFh, are represented by periods.

The following (BASIC) program will produce the result below it:

```
10 FOR I=0 TO 255
20 LPRINT CHR$(I);
30 NEXT I
40 LPRINT
50 END
```

After the program has been run, the printer's buffer should be flushed by pressing the **ON LINE** button.

00	01	02	03	04	05	06	07	08	09	0A	0B	0C	0D	0E	0F
10	11	12	13	14	15	16	17	18	19	1A	1B	1C	1D	1E	1F
20	21	22	23	24	25	26	27	28	29	2A	2B	2C	2D	2E	2F	!"#\$%&'()*+,-./
30	31	32	33	34	35	36	37	38	39	3A	3B	3C	3D	3E	3F	01234567 89:;<=>?
40	41	42	43	44	45	46	47	48	49	4A	4B	4C	4D	4E	4F	@ABCDEFGH IJKLMNO
50	51	52	53	54	55	56	57	58	59	5A	5B	5C	5D	5E	5F	PQRSTUVWXYZ[\]^_
60	61	62	63	64	65	66	67	68	69	6A	6B	6C	6D	6E	6F	`abcdefg hijklmno
70	71	72	73	74	75	76	77	78	79	7A	7B	7C	7D	7E	7F	pqrstuvwxyz{ }~
80	81	82	83	84	85	86	87	88	89	8A	8B	8C	8D	8E	8F
90	91	92	93	94	95	96	97	98	99	9A	9B	9C	9D	9E	9F
A0	A1	A2	A3	A4	A5	A6	A7	A8	A9	AA	AB	AC	AD	AE	AF
B0	B1	B2	B3	B4	B5	B6	B7	B8	B9	BA	BB	BC	BD	BE	BF
C0	C1	C2	C3	C4	C5	C6	C7	C8	C9	CA	CB	CC	CD	CE	CF
D0	D1	D2	D3	D4	D5	D6	D7	D8	D9	DA	DB	DC	DD	DE	DF
E0	E1	E2	E3	E4	E5	E6	E7	E8	E9	EA	EB	EC	ED	EE	EF
F0	F1	F2	F3	F4	F5	F6	F7	F8	F9	FA	FB	FC	FD	FE	FF
0D	0A															..

This mode is useful when installing and debugging software, to ensure that the characters and codes actually being received by the printer are those which are actually required.

8 Repeat the process for all print modes.

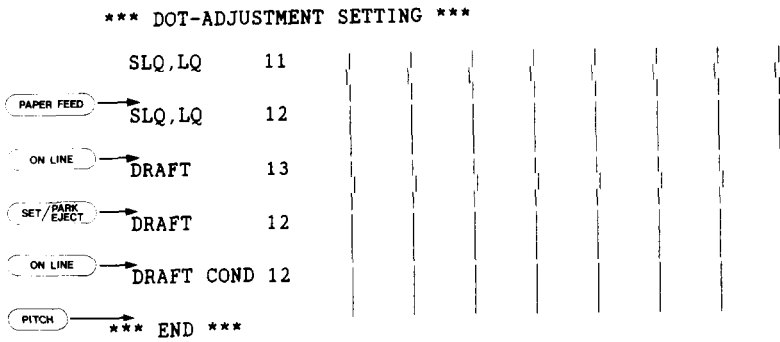

9 To exit from this mode, press the  button.

MEMO

When using your printer with an IBM PC, PC-XT or PC-AT or compatible, you will probably be using PC-DOS or MS-DOS as an operating system. A number of software tricks may be useful here. This section is not, however, a substitute for the operating system manuals supplied with your computer. To learn how to print files, etc, it is best to read the relevant parts of these manuals.

INSTALLING APPLICATION SOFTWARE WITH YOUR PRINTER

When installing application software, you may find that your printer is not specifically mentioned in the lists of printers given for installation. However, this should pose no problem. Read this section, and the guidelines provided with your software on printer installation.

If you have your printer set up in standard mode, then choose an Epson LQ850/1050 or NEC Pinwriter P6/P7 as your printer to be selected.

If neither of these are mentioned, choose one of the following (in order of preference): Star NB-15, Star NB24-10, Star NB24-15, Epson LQ-1000, Epson LQ-1500.

If you have your printer set up with the DIP switches to emulate an IBM Proprinter X24, simply choose this from the list of printers available in the application software list.

If the IBM Proprinter X24 is not mentioned, use either of the following choices (in order of preference): Proprinter II, Proprinter.

You may be able to customize your application software to install some of the control commands specific to your printer (for instance, changing fonts) which are not available to you under the standard emulation. For instance, if you are installing WordStar, you may wish to use the ^PQ, ^PW, ^PE and ^PR commands to choose different typefaces. This can all be done with the WordStar installation program. Read the section on escape sequences for details of how to change fonts (for example).

If your word-processor does not allow you to change fonts, it may allow a pause in printing. Insert a "pause" command in your text file at the point where you want to change fonts. When the document is printed, printing will then pause at that point. You can then put the printer off-line and change fonts with the front panel buttons. Then put the printer on-line again and resume printing.

If your software package does not mention printers by name, but asks instead what features your printer is capable of, the most common questions are: "Can your printer perform a backspace?" and "Can it do a hardware form feed?". You should answer "Yes" to both these questions.

Other software packages may well allow you to install specific features. Spreadsheet programs will often ask for the maximum number of columns to be printed. This is given below.

Number of columns	CPI	10" model	15" model
Pica	10	80	136
Elite	12	96	163
Semi-condensed	15	120	204
Condensed pica	17.1	137	233
Condensed elite	20	160	272
Proportional		Variable	Variable

Sometimes the software installation will ask you for an initialization sequence to return the printer to the default settings (specified by the Memory Switches). The command for your printer is <ESC> @ (1Bh, 40h).

Make sure that the DIP switches are set for the right printer emulation, and that you have selected the appropriate character set using the DIP switches.

If you are in any doubt about the configuration of your application software, seek expert advice. Your software supplier will probably be your most convenient reference.

GRAPHICS HARD COPY

On a PC-compatible computer running under MS-DOS, you can use the **(Shift)** and **(PrtSc)** keys on the computer together to obtain a printout of a text screen. To print out a graphics screen, you will have to run the program GRAPHICS.COM. See your MS-DOS manual for further details.

Continuous echoing of text output to the screen to the printer can be toggled on and off by use of the **(Ctrl) - (PrtSc)** or **(Ctrl) - (P)** key combinations.

SETTING UP THE PRINTER FROM THE DOS PROMPT

The PRINT command can be used to transmit control codes and escape sequences from a file to the printer in order to set up various parameters. For instance, if you want to set up letter quality printing, the command is **<ESC> x 1 (1Bh 78h 31h)**.

A file must therefore be created using these three characters. Though the MS-DOS line editor EDLIN can be used, there is a small difficulty in inputting the **<ESC>** character. This is achieved with the following sequence:

(Ctrl-V) (I)

and then the ASCII "x1" can be input. The file is then saved, and output to the printer. The session can therefore be something like the following:

```
A>EDLIN LQ.DAT
NEW FILE
*I
    1:*^V[x1
    2:*^C

*E

A>
```

Of course, if you have a text editor or word-processor which allows you to input characters such as the **<ESC>** character, this is probably preferable to using EDLIN. For full details of how to use EDLIN, consult your operating system manual.

The resulting file should be sent to the printer using the COPY command, eg:

```
A>COPY LQ.DAT PRN
```

prior to printing document files. Of course, this command can also be included in a batch file.

PROGRAMMING USING BASIC

As discussed earlier, a version of BASIC is usually supplied with PC-compatible machines. With this BASIC, characters are sent to the printer using the LPRINT command, and control codes are defined using the CHR\$() function.

Sample program

The following lines of BASIC give examples of how the printer may be driven from within your own programs:

```
1000 ' Set control codes
1010 E$=CHR$(27) 'Escape code
1020 D$=E$+"x0" 'Draft quality
1030 L$=E$+"x1" 'Letter quality
1040 F$=E$+"k" 'Select font
1050 C$=F$+CHR$(2)+L$ 'Select Courier
1060 H$=CHR$(9) 'Horizontal tab
1070 P$=E$+"P" 'Pica pitch
1080 ' Start printing
1090 WIDTH "LPT1:";255
1100 LPRINT E$;"D";CHR$(3);CHR$(27);CHR$(0);
1110 LPRINT C$;"Font settings:"
1120 LPRINT H$;D$;"Draft characters,";L$;
1130 LPRINT H$;F$;CHR$(0);"TMS ROMN characters,"
1140 LPRINT H$;F$;CHR$(1);"TW-Light characters,";
1150 LPRINT H$;F$;CHR$(2);"Courier characters,"
1160 LPRINT H$;F$;CHR$(3);"Prestige characters,";
1170 LPRINT H$;F$;CHR$(4);"Script characters,"
1180 LPRINT H$;F$;CHR$(5);"OCR-B characters,";
1190 LPRINT H$;F$;CHR$(6);"OCR-A characters,"
1200 LPRINT H$;F$;CHR$(7);"Letter-Gothic,";
1210 LPRINT H$;F$;CHR$(8);"Blippo characters,"
1220 LPRINT H$;F$;CHR$(9);"Orator characters,";
1230 LPRINT H$;F$;CHR$(10);"Helvet characters,"
1240 LPRINT H$;F$;CHR$(11);"Optimo characters,";
1250 LPRINT H$;F$;CHR$(12);"Cinema characters,"
1260 LPRINT H$;F$;CHR$(13);"CODE 39";
1270 LPRINT C$;" (CODE 39 characters),"
1280 LPRINT H$;F$;CHR$(14);"Greek characters,"
1290 LPRINT H$;F$;CHR$(20);"SLQ TMS ROMN and ";
1300 LPRINT F$;CHR$(21);"SLQ TW-Light characters"
```



```

1310 '
1320 LPRINT
1330 LPRINT C$;"Print pitches are:"
1340 LPRINT H$;P$;"Pica pitch (10 CPI),";
1350 LPRINT H$;E$;"M";"Elite pitch (12 CPI),"
1360 LPRINT H$;E$;"g";"Semi-condensed pitch (15 CPI),";
1370 LPRINT H$;P$;
1380 LPRINT CHR$(15); 'Select condensed print
1390 LPRINT "Condensed pica pitch (17 CPI),"
1400 LPRINT H$;E$;"M";"Condensed elite pitch (20 CPI),";
1410 LPRINT CHR$(18) 'Cancel condensed print
1420 LPRINT H$;E$;"p1"; 'Select proportional spacing
1430 LPRINT P$;"Normal proportional, ";
1440 LPRINT H$;CHR$(15);"and condensed proportional.";
1450 LPRINT CHR$(18);
1460 LPRINT E$;"p0" 'Cancel proportional spacing
1470 LPRINT
1480 LPRINT H$;E$;"w1";"Double-height,";E$;"w0"
1490 LPRINT H$;E$;"W1";"Double";E$;"W0";" and ";
1500 LPRINT CHR$(28);"E";CHR$(2);"Triple";
1510 LPRINT CHR$(28);"E";CHR$(0);" width,"
1520 LPRINT H$;E$;"h";CHR$(1);"Double-sized,"
1530 LPRINT H$;E$;"h";CHR$(2);"Quad-sized.";
1540 LPRINT E$;"h";CHR$(0)
1550 LPRINT :LPRINT
1560 '
1570 LPRINT E$;"Q";CHR$(47) 'Set right margin
1580 LPRINT C$;"Various line and character spacings:"
1590 LPRINT E$;"a1" 'Center text
1600 FOR I=1 TO 6
1610 LPRINT E$;"A";CHR$(I); 'Set line spacing
1620 LPRINT E$;" ";CHR$(I); 'Increase character space
1630 LPRINT "THE SPACINGS ARE CHANGED"
1640 NEXT I
1650 FOR I=6 TO 1 STEP -1
1660 LPRINT E$;"A";CHR$(I); 'Set line spacing
1670 LPRINT E$;" ";CHR$(I); 'Increase character space
1680 LPRINT "THE SPACINGS ARE CHANGED"
1690 NEXT I
1700 LPRINT E$;"a0" 'Left justify
1710 LPRINT E$;"3";CHR$(30); 'Set 1/6" line spacing
1720 LPRINT E$;" ";CHR$(0); 'Normal character space
1730 LPRINT :LPRINT E$;"Q";CHR$(80)
1740 '
1750 LPRINT C$;"Other features:"
1760 LPRINT H$;E$;"q";CHR$(1);"OUTLINE";",", ";E$;"q";CHR$(0);
1770 LPRINT E$;"q";CHR$(2);"SHADOW";",", ";E$;"q";CHR$(0);
1780 LPRINT E$;"q";CHR$(3);"OUTLINE & SHADOW";",", ";
1790 LPRINT E$;"q";CHR$(0);
1800 LPRINT E$;"4";"Italics";E$;"5";",", "
1810 LPRINT H$;E$;"E";"Emphasized";E$;"F";",", "
1820 LPRINT E$;"G";"Double-strike";E$;"H";",", "
1830 LPRINT E$;"-1";"Underlining";E$;"-0";",", "
1840 LPRINT H$;E$;"_1";"Overlining";E$;"_0";",", "
1850 LPRINT E$;"S0";"SUPERSCRIPT";E$;"T";",", "
1860 LPRINT E$;"S1";"SUBSCRIPT";E$;"T";",", "
1870 LPRINT H$;C$;"Download characters: ";

```

```

1880 GOSUB 3020
1890 LPRINT E$;"S0";          'Select superscript
1900 LPRINT E$;"%1";         'Select download character
1910 FOR I=1 TO 5
1920 LPRINT CHR$(60);        'Print download character
1930 NEXT I
1940 LPRINT E$;"%0";         'Select normal character
1950 LPRINT E$;"T";          'Cancel superscript
1960 GOSUB 3150
1970 LPRINT E$;"%1";         'Select download character
1980 FOR I=1 TO 5
1990 LPRINT CHR$(60);        'Print download character
2000 NEXT I
2010 LPRINT E$;"%0";         'Select normal character
2020 GOSUB 3020
2030 LPRINT E$;"S1";         'Select subscript
2040 LPRINT E$;"%1";         'Select download character
2050 FOR I=1 TO 5
2060 LPRINT CHR$(60);        'Print download character
2070 NEXT I
2080 LPRINT E$;"%0";         'Select normal character
2090 LPRINT E$;"T"           'Cancel subscript
2100 LPRINT H$;C$;"Dot graphics:";CHR$(13);
2110 DIM LOGO$(4)
2120 RESTORE 4230
2130 FOR ROW=1 TO 4
2140 FOR COL=1 TO 65
2150 READ GD
2160 LOGO$(ROW)=LOGO$(ROW)+CHR$(GD)
2170 NEXT COL
2180 NEXT ROW
2190 LPRINT E$;"A";CHR$(8);  'Set 8/60" line spacing
2200 FOR ROW=1 TO 4
2210 LPRINT " ";
2220 FOR B=0 TO 6
2230 IF B=2 THEN 2280
2240 IF B=5 THEN 2280
2250 LPRINT E$;"*";CHR$(B);  'Select normal density
2260 LPRINT CHR$(65);CHR$(0);LOGO$(ROW);
2270 LPRINT " ";
2280 NEXT B
2290 LPRINT
2300 NEXT ROW
2310 LPRINT E$;"@"           'Initialize printer
2320 END
3000 '
3010 ' SUBROUTINES
3020 ' Define super/subscript download character
3030 LPRINT E$;"S1";E$;" ";CHR$(0);CHR$(0);CHR$(0);
3040 LPRINT E$;"&";CHR$(0);CHR$(60);CHR$(60);
3050 RESTORE 4020
3060 READ LS :LPRINT CHR$(LS);
3070 READ CW :LPRINT CHR$(CW);
3080 READ RS :LPRINT CHR$(RS);
3090 FOR M=1 TO CW*2
3100 READ MM
3110 LPRINT CHR$(MM);

```

```

3120 NEXT M
3130 RETURN
3140 '
3150 ' Define LQ pica download character
3160 LPRINT C$;
3170 LPRINT E$;"&";CHR$(0);CHR$(60);CHR$(60);
3180 RESTORE 4100
3190 READ LS :LPRINT CHR$(LS);
3200 READ CW :LPRINT CHR$(CW);
3210 READ RS :LPRINT CHR$(RS);
3220 FOR M=1 TO CW*3
3230 READ MM
3240 LPRINT CHR$(MM);
3250 NEXT M
3260 RETURN
4000 '
4010 ' DATA
4020 ' Super/subscript download character data
4030 DATA 7, 23, 6
4040 DATA 12, 0, 16, 0, 44, 0, 80, 0, 44,120
4050 DATA 64,128, 33,120, 94,128, 33,120, 94,128
4060 DATA 33, 24, 66, 0, 33, 24, 94,128, 33,120
4070 DATA 94,128, 33,120, 64,128, 44,120, 80, 0
4080 DATA 44, 0, 16, 0, 12, 0
4090 '
4100 ' LQ pica download characer data
4110 DATA 4, 29, 3
4120 DATA 7, 0, 0, 8, 0, 0, 23, 0, 0
4130 DATA 40, 0, 0, 19, 15,192, 40, 16, 0
4140 DATA 80, 47,192, 32, 80, 0, 80,175,192
4150 DATA 47, 80, 0, 80,175,192, 47, 80, 0
4160 DATA 80,163,192, 33, 64, 0, 80,163,192
4170 DATA 33, 64, 0, 80,163,192, 47, 80, 0
4180 DATA 80,175,192, 47, 80, 0, 80,175,192
4190 DATA 32, 80, 0, 80, 47,192, 40, 16, 0
4200 DATA 19, 15,192, 40, 0, 0, 23, 0, 0
4210 DATA 8, 0, 0, 7, 0, 0
4220 '
4230 ' Dot graphics data
4240 ' ROW 1
4250 DATA 0, 0, 0, 0, 1, 3, 7, 7, 7, 15
4260 DATA 14, 14, 14, 14, 14, 7, 7, 3, 3, 15
4270 DATA 15, 15, 0, 0, 0, 0, 6, 7, 7, 7
4280 DATA 7, 7, 7, 7, 7, 6, 6, 0, 0, 7
4290 DATA 7, 7, 7, 7, 7, 7, 7, 7, 7, 7
4300 DATA 0, 0, 7, 7, 7, 7, 7, 7, 7, 7
4310 DATA 7, 7, 0, 0, 0
4320 ' ROW 2
4330 DATA 0, 0, 60,255,255,255,255,255,143, 15
4340 DATA 7, 7, 7, 7, 3, 3, 3,131,193,241
4350 DATA 240,240, 0, 0, 0, 0, 0, 0,224,255
4360 DATA 255,255,255,255,31, 0, 0, 0, 1, 3
4370 DATA 31,255,255,255,255,255,255, 1, 0, 0
4380 DATA 0, 1, 7, 31,255,252,240,192,128, 0
4390 DATA 0, 0, 0, 0, 0
4400 ' ROW 3
4410 DATA 0, 31, 31, 3,129,128,192,192,192,192

```

```

4420 DATA 192,224,224,224,224,240,255,255,255,255
4430 DATA 255,127,0,0,0,0,0,0,0,192
4440 DATA 255,255,255,255,255,15,15,63,252,240
4450 DATA 192,0,240,255,255,255,255,255,7,15
4460 DATA 127,252,240,192,0,0,0,0,0,0
4470 DATA 0,0,0,0,0
4480 ' ROW 4
4490 DATA 0,248,248,240,224,224,112,112,56,56
4500 DATA 56,56,56,120,120,240,240,224,224,192
4510 DATA 128,0,0,0,0,0,0,0,0,0
4520 DATA 128,248,248,248,248,240,192,0,0,0
4530 DATA 0,0,240,248,248,248,248,240,192,0
4540 DATA 0,0,0,0,0,0,0,0,0,0
4550 DATA 0,0,0,0,0

```

This will produce the following results as shown on page 102.

How the program works

This program begins by assigning a number of printer commands to BASIC string variables (lines 1000 to 1070). You can find most of these commands near the beginning of chapter 4.

The WIDTH "LPT1:" 255 statement in line 1090 means infinite line width. It prevents the IBM-PC from inserting unwanted carriage returns and line feeds in graphics data.

Actual printing begins in line 1100. Using the preassigned commands, the program prints samples of its different font styles, followed by samples of the print pitches, then some double and quadruple-sized printing.

Next comes the central attraction of the program: a line of text printed twelve times in expanding and contracting loops to give a barrel effect. The work is done by four printer commands: a command setting the right margin (line 1570); a centering command (line 1590); a command to vary the line spacing (lines 1610 and 1660); and a command to micro-adjust the space between characters (lines 1620 and 1670).

Next the program returns to normal spacing and gives a demonstration of the printer's word-processing abilities: outlined printing, bold printing, underlining, subscripts, etc.

The row of telephone symbols in the next printed line is created by downloading two new character patterns, which are printed in place of the character "<" (character 60).

The final part of the program uses dot graphics to print an "SW" logo. The dot pattern of the logo was originally laid out on graph paper, then converted to the data in lines 4240 to 4550 with the help of a calculator. Each number represents eight vertical dots. (See "Graphics commands" in Chapter 4 for details.)

The pattern is printed in four rows, each eight dots high and 65 dots wide. Lines 2110 to 2180 read the dot data into a string array variable named LOGO\$. Line 2190 sets the line spacing to 8/60 inch so that the rows will connect vertically. The loop in lines 2200 to 2300 does the printing in four passes of the print head.

This program can also be run in IBM mode if you change a few of the lines as shown below to allow for differences in some of the commands. You will get a cylinder instead of a barrel effect, because the IBM mode does not have any command to micro-adjust the character spacing.

Modifications for IBM mode:

```
1070 P$=CHR$(18)           'Pica pitch
1350 LPRINT H$;E$;";";"Elite pitch (12 CPI),"
1360 ' LPRINT H$;E$;"g";"Semi-condensed pitch (15 CPI),"
1390 LPRINT H$;"Condensed pitch (17 CPI),"
1400 ' LPRINT H$;E$;"M";"Condensed elite pitch (20 CPI),"
1490 LPRINT H$;E$;"W1";"Double width";E$;"W0"
1500 ' LPRINT CHR$(28);"E";CHR$(2);"Triple";
1510 ' LPRINT CHR$(28);"E";CHR$(0);" width,"
1570 LPRINT CHR$(28);"Q";CHR$(47) 'Set right margin
1610 LPRINT E$;"A";CHR$(1);E$;"2"; 'Set line spacing
1620 ' LPRINT E$;" ";CHR$(1); 'Increase character space
1660 LPRINT E$;"A";CHR$(1);E$;"2"; 'Set line spacing
1670 ' LPRINT E$;" ";CHR$(1); 'Increase character space
1710 LPRINT E$;"3";CHR$(36); 'Set 1/6" line spacing
1720 ' LPRINT E$;" ";CHR$(0); 'Normal character space
1730 LPRINT :LPRINT CHR$(28);"Q";CHR$(80)
1760 ' LPRINT H$;E$;"q";CHR$(1);"OUTLINE";", ",E$;"q";CHR$(0);
1770 ' LPRINT E$;"q";CHR$(2);"SHADOW";", ",E$;"q";CHR$(0);
1780 ' LPRINT E$;"q";CHR$(3);"OUTLINE & SHADOW";", ";
1790 ' LPRINT E$;"q";CHR$(0);
1800 LPRINT H$;CHR$(28);"4";"Italics";CHR$(28);"5";", "
2190 LPRINT E$;"A";CHR$(8);E$;"2"; 'Set 8/60" line spacing
3030 LPRINT E$;"S1";CHR$(28);":";CHR$(0);CHR$(0);CHR$(0);
3040 LPRINT E$;"=";CHR$(0);CHR$(60);CHR$(60);
3170 LPRINT E$;"=";CHR$(0);CHR$(60);CHR$(60);
```

Font settings:

Draft characters,	TMS ROMN characters,
TW-Light characters,	Courier characters,
Prestige characters,	<i>Script characters,</i>
OCR-B characters,	OCR-A characters,
Letter-Gothic,	Blippo characters,
ORATOR CHARACTERS,	Helvet characters,
Optimo characters.	Cinema characters,

 (CODE 39 characters),
 Greek characters,
 SLQ TMS ROMN and SLQ TW-Light characters

Print pitches are:

Pica pitch (10 CPI),	Elite pitch (12 CPI),
Semi-condensed pitch (15 CPI),	Condensed pica pitch (17 CPI),
Condensed elite pitch (20 CPI),	
Normal proportional,	and condensed proportional.

Double-height,
 Double and Triple width,
 Double-sized,

Quad-sized.

Various line and character spacings:

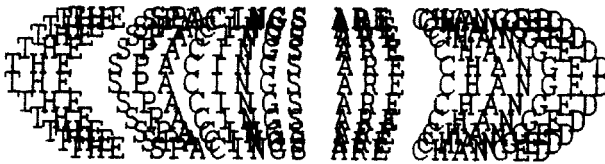

Other features:

OUTLINE, SHADOW, OUTLINE & SHADOW, Italics,
Emphasized, Double-strike, Underlining,
Overlining, SUPERSCRIP^T, SUBSCRIP_T,
 Download characters: *****
 Dot graphics:



Of course, many more facilities are available with the printer, but this may give you some ideas as to how you can drive the printer using your own programs.

Patches necessary to use the BASIC interpreter

When using the Microsoft BASIC interpreter usually supplied with PCs and compatibles, a number of problems may arise. Firstly, if the interpreter transmits a carriage return (0Dh) character to the printer, it automatically transmits a line feed as well. Secondly, the BASIC interpreter will not transmit EOF markers (1Ah) at all. Normally, this will not cause problems, but if such a character is included in a character definition or graphic data string, problems may occur. To get round these two problems, the use of the following subroutine patches is recommended:

```
1260 LPRINT H$;F$; :I=13 :GOSUB 5000 :LPRINT "CODE 39";
```

Monochrome display

```
5000 '  
5010 O=INP(&H3BD) :IF O<128 THEN 5010  
5020 OUT &H3BC,I :OUT &H3BE,5 :OUT &H3BE,4  
5030 RETURN
```

Color display

```
5000 '  
5010 O=INP(&H379) :IF O<128 THEN 5010  
5020 OUT &H378,I :OUT &H37A,5 :OUT &H37A,4  
5030 RETURN
```

Call these subroutines when downloading characters or bit-image data, instead of using an LPRINT CHR\$(I) statement. For other languages, check the documentation to see how the compiler/interpreter handles end-of-line and end-of-file characters.

NOTE

<p>These patches are only for use with Microsoft BASIC interpreters under PC-DOS or MS-DOS on PCs/PC-ATs or compatibles. They will not work with other languages, machines and/or operating systems.</p>
--

MEMO

Chapter 8

SPECIFICATIONS

Printing system	Serial Impact Dot-matrix
Printing speed	200 cps (Draft pica) 67 cps (LQ pica)
Print direction	Bidirectional, logic-seeking Unidirectional, logic-seeking (selectable)
Number of print pins	24
Line spacing	1/6, 1/8, <i>n</i> /180, <i>n</i> /360 inches
Characters	Draft
	ASCII 96
	International 14 sets (*)
	IBM special 111
	Super/subscript 257
	LQ,SLQ
	ASCII 96
	International 14 sets (*)
	IBM special 111
	IBM block graphic 50
	Super/subscript 257
	Download (draft or LQ) 128 (255 **)

* USA, France, Germany, England, Denmark I, Sweden, Italy, Spain I, Japan, Norway, Denmark II, Spain II, Latin America, Denmark/Norway

** In pica pitch if optional RAM card has been installed

Number of columns	CPI	10" model	15" model
Pica	10	80	136
Elite	12	96	163
Semi-condensed	15	120	204
Condensed pica	17.1	137	233
Condensed elite	20	160	272
Proportional		Variable	Variable
Character dot matrix	Draft	LQ	SLQ
Pica	24 x 9	24 x 35	48 x 35
Elite	24 x 9	24 x 29	48 x 29
Semi-condensed	16 x 7	16 x 23	-
Condensed pica	24 x 9	24 x 18	48 x 18
Condensed elite	24 x 9	24 x 15	48 x 15
Super/subscript	16 x 7	16 x 23	-
Proportional	-	24 x <i>n</i>	48 x <i>n</i>
Super/subscript proportional	-	16 x <i>n</i>	-
Bit image dot-matrix	DPI	10" model	15" model
8-pin single	60	8 x 480	8 x 816
8-pin double	120	8 x 960	8 x 1632
8-pin high-speed double*	120	8 x 960	8 x 1632
8-pin quadruple*	240	8 x 1920	8 x 3264
8-pin CRT I	80	8 x 640	8 x 1088
8-pin CRT II	90	8 x 720	8 x 1224
24-pin single	60	24 x 480	24 x 816
24-pin double	120	24 x 960	24 x 1632
24-pin CRT III	90	24 x 720	24 x 1224
24-pin Triple	180	24 x 1440	24 x 2448
24-pin hex*	360	24 x 2880	24 x 4896

* It is impossible to print adjacent dots in the modes marked with an asterisk (*).

Paper feed	Friction and push tractor (standard) Pull tractor (option)	
Paper feed speed	3.66 inches/second max (without ASF) 3.43 inches/second (with ASF)	
Paper width	10"model	15"model
Cut sheet	5.5"-11.7"	6"-16.5"
Fanfold (continuous)	3"-10"	4"-16"
Copies	Original + 3 copies	
Maximum buffer size	10"model	15"model
(DOWNLOAD=NO)		
Without IC card	27k	41k
With IC card	59k	73k
(DOWNLOAD=YES)		
Without IC card	12k	26k
With IC card	27k	41k
Emulations	Epson and NEC mode IBM Proprinter mode	
Interface	Centronics parallel (standard) RS-232C serial (option)	
Ribbon type	On-carriage, dedicated Black (standard), Color (option)	
Ribbon life	3 million characters (draft pica)	
Dimensions (10" model)	451(w) x 341(d) x 139(h) mm 17.8(w) x 13.4(d) x 5.47(h) in	
Dimensions (15" model)	593(w) x 341(d) x 139(h) mm 23.4(w) x 13.4(d) x 5.47(h) in	
Weight (10" model)	8kg (17.6lb)	
Weight (15" model)	10.5kg (23.1lb)	

Power supply 120VAC, 220VAC, 240VAC, 50/60Hz
 (varies according to the country of purchase)

Options Automatic sheet feeder
 RS-232C interface
 Color printing kit
 Character font card (64k)
 Battery-backed RAM card (32k)
 Pull tractor feed

The following describes the pinout of the parallel (Centronics-type) interface connector (signals which are low when active are overlined):

Pin	Name	Function
1	<u>STROBE</u>	Goes from high to low (for $\geq 0.5\mu\text{s}$) when active
2	DATA0	High when active
3	DATA1	High when active
4	DATA2	High when active
5	DATA3	High when active
6	DATA4	High when active
7	DATA5	High when active
8	DATA6	High when active
9	DATA7	High when active
10	<u>ACK</u>	5 μs low pulse acknowledges receipt of data
11	BUSY	Low when printer ready to receive data
12	PAPER	High when paper out. Can be disabled with Memory Switch setting
13	SELECT	High when printer is on-line
14, 15	N/C	
16	SIGNAL GND	Signal ground
17	CHASSIS	Chassis ground (isolated from signal ground)
18	+5V	+5V DC output from printer
19~30	GND	Twisted pair ground return
31	<u>RESET</u>	When this input signal is low, printer is reset
32	<u>ERROR</u>	Outputs low when printer cannot continue, due to an error
33	EXT GND	External ground
34, 35	N/C	
36	<u>SELECT IN</u>	Always high

Chapter 9

CHARACTER SETS

This chapter gives tables of the printer's standard and IBM character sets. In the following character set charts, the printer fonts are divided into four families:

- Family 1: All fonts except those listed below:
- Family 2: OCR-A
- Family 3: Code 39
- Family 4: Greek

The decimal character code of each character is shown in an inset to the lower right of the character.

The hexadecimal code can be found by reading the entries at the top and left edges of the table. for example, the character "A" is in column 4 and row 1, so its hexadecimal character code is 41. this is equivalent ($4 \times 16 + 1 = 65$) to decimal 65, the number in the inset.

Control codes recognized by this printer are indicated by abbreviations inside pointed brackets.< >.

<Sample>

	0	1	2	3	4	5	6	7
0	<NUL> 0			0	@	P		p
1		<DC1> 1	!	1	A	Q	a	q
2		<DC2> 2	"	2	B	R	b	r
3					C			

Character

Hexadecimal value (high order)

Control code

Hexadecimal value (low order)

Decimal value

STANDARD CHARACTER SET #1

Family 1

	0	1	2	3	4	5	6	7
0	<NUL> 0	16	32	0	@	P	`	p
1	1	<DC1> 17	33	1	A	Q	a	q
2	2	<DC2> 18	34	2	B	R	b	r
3	3	<DC3> 19	35	3	C	S	c	s
4	4	<DC4> 20	36	4	D	T	d	t
5	5	21	37	5	E	U	e	u
6	6	22	38	6	F	V	f	v
7	<BEL> 7	23	39	7	G	W	g	w
8	<BS> 8	<CAN> 24	40	8	H	X	h	x
9	<HT> 9	 25	41	9	I	Y	i	y
A	<LF> 10	26	42	:	J	Z	j	z
B	<VT> 11	<ESC> 27	43	;	K	[k	{
C	<FF> 12	<FS> 28	44	<	L	\	l	
D	<CR> 13	29	45	=	M]	m	}
E	<SO> 14	30	46	>	N	^	n	~
F	<SI> 15	31	47	?	O	-	o	 127



























	8	9	A	B	C	D	E	F
0	<NUL> 128	144	160	0 176	@ 192	P 208	` 224	p 240
1	<DC1> 129	145	! 161	1 177	A 193	Q 209	a 225	q 241
2	<DC2> 130	146	" 162	2 178	B 194	R 210	b 226	r 242
3	<DC3> 131	147	# 163	3 179	C 195	S 211	c 227	s 243
4	<DC4> 132	148	\$ 164	4 180	D 196	T 212	d 228	t 244
5	133	149	% 165	5 181	E 197	U 213	e 229	u 245
6	134	150	& 166	6 182	F 198	V 214	f 230	v 246
7	<BEL> 135	151	' 167	7 183	G 199	W 215	g 231	w 247
8	<BS> 136	<CAN> 152	(168	8 184	H 200	X 216	h 232	x 248
9	<HT> 137	 153) 169	9 185	I 201	Y 217	i 233	y 249
A	<LF> 138	154	* 170	: 186	J 202	Z 218	j 234	z 250
B	<VT> 139	<ESC> 155	+ 171	; 187	K 203	[219	k 235	{ 251
C	<FF> 140	<FS> 156	, 172	< 188	L 204	\ 220	l 236	 252
D	<CR> 141	157	- 173	= 189	M 205] 221	m 237	} 253
E	<SO> 142	158	. 174	> 190	N 206	^ 222	n 238	~ 254
F	<SI> 143	159	/ 175	? 191	O 207	_ 223	o 239	 255











































Family 2

	0	1	2	3	4	5	6	7
0	<NUL> 0	16	32	48	64	80	96	p
1	1	<DC1> 17	33	49	65	81	a	q
2	2	<DC2> 18	34	50	66	82	b	r
3	3	<DC3> 19	35	51	67	83	c	s
4	4	<DC4> 20	36	52	68	84	d	t
5	5	21	37	53	69	85	e	u
6	6	22	38	54	70	86	f	v
7	<BEL> 7	23	39	55	71	87	g	w
8	<BS> 8	<CAN> 24	40	56	72	88	h	x
9	<HT> 9	 25	41	57	73	89	i	y
A	<LF> 10	26	42	58	74	90	j	z
B	<VT> 11	<ESC> 27	43	59	75	91	k	(
C	<FF> 12	<FS> 28	44	60	76	92	l	
D	<CR> 13	29	45	61	77	93	m)
E	<SO> 14	30	46	62	78	94	n	~
F	<SI> 15	31	47	63	79	95	o	

	8	9	A	B	C	D	E	F
0	<NUL> 128	144	160	D 176	d 192	P 208	p 224	240
1	<DC1> 129	145	Y 161	1 177	A 193	Q 209	a 225	q 241
2	<DC2> 130	146	" 162	2 178	B 194	R 210	b 226	r 242
3	<DC3> 131	147	' 163	3 179	C 195	S 211	c 227	s 243
4	<DC4> 132	148	\$ 164	4 180	D 196	T 212	d 228	t 244
5	133	149	% 165	5 181	E 197	U 213	e 229	u 245
6	134	150	& 166	6 182	F 198	V 214	f 230	v 246
7	<BEL> 135	151	' 167	7 183	G 199	W 215	g 231	w 247
8	<BS> 136	<CAN> 152	€ 168	B 184	H 200	X 216	h 232	x 248
9	<HT> 137	 153	3 169	9 185	I 201	Y 217	i 233	y 249
A	<LF> 138	154	* 170	: 186	J 202	Z 218	j 234	z 250
B	<VT> 139	<ESC> 155	+ 171	; 187	K 203	[219	k 235	(251
C	<FF> 140	<FS> 156	, 172	█ 188	L 204	\ 220	l 236	/ 252
D	<CR> 141	157	- 173	= 189	M 205] 221	m 237) 253
E	<SO> 142	158	. 174	█ 190	N 206	^ 222	n 238	~ 254
F	<SI> 143	159	/ 175	? 191	o 207	_ 223	o 239	 255

Family 3

	0	1	2	3	4	5	6	7
0	<NUL> 0	16			64		96	112
1	<DC1> 1	17	33		65		97	113
2	<DC2> 2	18	34		66		98	114
3	<DC3> 3	19	35		67		99	115
4	<DC4> 4	20			68		100	116
5	5	21		53	69		101	117
6	6	22	38		70		102	118
7	<BEL> 7	23	39	55	71		103	119
8	<BS> 8	<CAN> 24	40		72		104	120
9	<HT> 9	 25	41		73		105	121
A	<LF> 10	26		58	74		106	122
B	<VT> 11	<ESC> 27	43	59	75	91	107	123
C	<FF> 12	<FS> 28	44	60	76	92	108	124
D	<CR> 13	29		61	77	93	109	125
E	<SO> 14	30		62	78	94	110	126
F	<SI> 15	31		63	79	95	111	 127

	8	9	A	B	C	D	E	F
0	<NUL> 128	144	 160	 176	192	 208	224	240
1	129	<DC1> 145	161	 177	 193	 209	225	241
2	130	<DC2> 146	162	 178	 194	 210	226	242
3	131	<DC3> 147	163	 179	 195	 211	227	243
4	132	<DC4> 148	 164	 180	 196	 212	228	244
5	133	149	 165	 181	 197	 213	229	245
6	134	150	166	 182	 198	 214	230	246
7	<BEL> 135	151	167	 183	 199	 215	231	247
8	<BS> 136	<CAN> 152	168	 184	 200	 216	232	248
9	<HT> 137	 153	169	 185	 201	 217	233	249
A	<LF> 138	154	170	186	 202	 218	234	250
B	<VT> 139	<ESC> 155	171	187	 203	219	235	251
C	<FF> 140	<FS> 156	172	188	 204	220	236	252
D	<CR> 141	157	 173	189	 205	221	237	253
E	<SO> 142	158	 174	190	 206	222	238	254
F	<SI> 143	159	 175	191	 207	223	239	255

Family 4

	0	1	2	3	4	5	6	7	
0	<NUL> 0	16	32	48	@	P	`	p	
1	1	<DC1> 17	33	49	A	Q	a	q	
2	2	<DC2> 18	34	50	B	R	b	r	
3	3	<DC3> 19	35	51	C	S	c	s	
4	4	<DC4> 20	36	52	D	T	d	t	
5	5	21	37	53	E	U	e	u	
6	6	22	38	54	F	V	f	v	
7	<BEL> 7	23	39	55	G	W	g	w	
8	<BS> 8	<CAN> 24	(40	56	H	X	h	x
9	<HT> 9	 25)	41	57	I	Y	i	y
A	<LF> 10	26	*	42	58	J	Z	j	z
B	<VT> 11	<ESC> 27	+	43	59	K	[k	{
C	<FF> 12	<FS> 28	,	44	60	L	\	l	
D	<CR> 13	29	-	45	61	M]	m	}
E	<SO> 14	30	.	46	62	N	^	n	~
F	<SI> 15	31	/	47	63	O	_	o	
	15	31	47	63	79	95	111	127	

	8	9	A	B	C	D	E	F
0	<NUL> 128	144	160	176	192	208	224	p 240
1	129	<DC1> 145	!	1	A	Q	a	q 241
2	130	<DC2> 146	"	2	B	R	b	r 242
3	131	<DC3> 147	#	3	C	S	c	s 243
4	132	<DC4> 148	\$	4	D	T	d	t 244
5	133	149	%	5	E	U	e	u 245
6	134	150	&	6	F	V	f	v 246
7	<BEL> 135	151	'	7	G	W	g	w 247
8	<BS> 136	<CAN> 152	(8	H	X	h	x 248
9	<HT> 137	 153)	9	I	Y	i	y 249
A	<LF> 138	154	*	:	J	Z	j	z 250
B	<VT> 139	<ESC> 155	+	;	K	[k	{ 251
C	<FF> 140	<FS> 156	,	<	L	\	l	/ 252
D	<CR> 141	157	-	=	M]	m	} 253
E	<SO> 142	158	.	>	N	^	n	~ 254
F	<SI> 143	159	/	?	O	_	o	 255

STANDARD CHARACTER SET #2

Other characters are identical to Standard character set #1.

Family 1

	8	9
0	à 128	š 144
1	è 129	ß 145
2	ù 130	Æ 146
3	ò 131	æ 147
4	ï 132	ø 148
5	° 133	ø 149
6	£ 134	” 150
7	í 135	Ā 151
8	í 136	ö 152
9	ñ 137	ü 153
A	ñ 138	ä 154
B	π 139	ö 155
C	ř 140	ü 156
D	Ā 141	É 157
E	á 142	é 158
F	ç 143	¥ 159

Family 2

	8	9
0	à 128	ŕ 144
1	è 129	ß 145
2	ù 130	Æ 146
3	ò 131	æ 147
4	ï 132	ø 148
5	° 133	ø 149
6	£ 134	” 150
7	í 135	Ā 151
8	í 136	ö 152
9	ñ 137	ü 153
A	ñ 138	ä 154
B	π 139	ö 155
C	ř 140	ü 156
D	Ā 141	É 157
E	á 142	é 158
F	ç 143	¥ 159

Family 3

	8	9
0	128	144
1	129	145
2	130	146
3	131	147
4	132	148
5	133	149
6	134	150
7	135	151
8	136	152
9	137	153
A	138	154
B	139	155
C	140	156
D	141	157
E	142	158
F	143	159

Family 4

	8	9
0	à 128	š 144
1	è 129	ß 145
2	ù 130	Æ 146
3	ò 131	æ 147
4	ì 132	ø 148
5	ó 133	ø 149
6	£ 134	.. 150
7	ï 135	Ä 151
8	¿ 136	ö 152
9	ñ 137	ü 153
A	ñ 138	ä 154
B	α 139	ö 155
C	ℓ 140	ü 156
D	À 141	É 157
E	á 142	é 158
F	ç 143	¥ 159

IBM CHARACTER SET #2

Family 1

	0	1	2	3	4	5	6	7
0	<NUL> 0	16	32	48	@	P	`	p
1	1	<DC1> 17	33	49	A	Q	a	q
2	2	<DC2> 18	34	50	B	R	b	r
3	♥ 3	<DC3> 19	#	51	C	S	c	s
4	♦ 4	<DC4> 20	\$	52	D	T	d	t
5	♣ 5	§	%	53	E	U	e	u
6	♠ 6	22	&	54	F	V	f	v
7	<BEL> 7	23	'	55	G	W	g	w
8	<BS> 8	<CAN> 24	(56	H	X	h	x
9	<HT> 9	 25)	57	I	Y	i	y
A	<LF> 10	26	*	58	J	Z	j	z
B	<VT> 11	<ESC> 27	+	59	K	[k	{
C	<FF> 12	<FS> 28	,	60	L	\	l	!
D	<CR> 13	29	-	61	M]	m	}
E	<SO> 14	30	.	62	N	^	n	~
F	<SI> 15	31	/	63	O	_	o	

	8	9	A	B	C	D	E	F
0	Ç 128	È 144	á 160	⋯ 176	ℒ 192	⋈ 208	α 224	≡ 240
1	ü 129	æ 145	í 161	⋯ 177	± 193	⋈ 209	β 225	± 241
2	é 130	Æ 146	ó 162	⋯ 178	⋈ 194	⋈ 210	Γ 226	≥ 242
3	â 131	ô 147	ú 163	 179	† 195	⋈ 211	π 227	≤ 243
4	ä 132	ö 148	ñ 164	† 180	- 196	⋈ 212	Σ 228	∫ 244
5	à 133	ò 149	ñ 165	† 181	† 197	∫ 213	σ 229	∫ 245
6	á 134	û 150	á 166	† 182	∫ 198	∫ 214	μ 230	÷ 246
7	ç 135	ù 151	ó 167	∫ 183	∫ 199	∫ 215	τ 231	≈ 247
8	ê 136	ÿ 152	¿ 168	∫ 184	⋈ 200	∫ 216	Φ 232	° 248
9	ë 137	ö 153	ƒ 169	∫ 185	∫ 201	∫ 217	Θ 233	▪ 249
A	è 138	ù 154	ƒ 170	∫ 186	⋈ 202	∫ 218	Ω 234	- 250
B	ï 139	ϕ 155	½ 171	∫ 187	∫ 203	■ 219	δ 235	√ 251
C	î 140	£ 156	¾ 172	∫ 188	∫ 204	■ 220	∞ 236	n 252
D	ì 141	¥ 157	ì 173	∫ 189	= 205	■ 221	∅ 237	² 253
E	Ä 142	ƒ 158	« 174	∫ 190	∫ 206	■ 222	ε 238	▪ 254
F	À 143	ƒ 159	» 175	∫ 191	⋈ 207	■ 223	∩ 239	

Family 2

	0	1	2	3	4	5	6	7
0	<NUL> 0	16	32	48	64	80	96	p 112
1	1	<DC1> 17	33	49	65	81	a 97	q 113
2	2	<DC2> 18	34	50	66	82	b 98	r 114
3	♥ 3	<DC3> 19	35	51	67	83	c 99	s 115
4	♦ 4	<DC4> 20	36	52	68	84	d 100	t 116
5	♣ 5	11	37	53	69	85	e 101	u 117
6	♠ 6	22	38	54	70	86	f 102	v 118
7	<BEL> 7	23	39	55	71	87	g 103	w 119
8	<BS> 8	<CAN> 24	40	56	72	88	h 104	x 120
9	<HT> 9	 25	41	57	73	89	i 105	y 121
A	<LF> 10	26	42	58	74	90	j 106	z 122
B	<VT> 11	<ESC> 27	43	59	75	91	k 107	(123
C	<FF> 12	<FS> 28	44	60	76	92	l 108	124
D	<CR> 13	29	45	61	77	93	m 109) 125
E	<SO> 14	30	46	62	78	94	n 110	~ 126
F	<SI> 15	31	47	63	79	95	o 111	 127

	8	9	A	B	C	D	E	F
0	Ç 128	É 144	á 160	⋯ 176	Ł 192	⋈ 208	α 224	≡ 240
1	Ü 129	æ 145	í 161	⋯ 177	⊥ 193	⋈ 209	β 225	± 241
2	é 130	Æ 146	ó 162	⋯ 178	⊤ 194	⋈ 210	Γ 226	≥ 242
3	â 131	ô 147	ú 163	 179	† 195	⋈ 211	π 227	≤ 243
4	ä 132	ö 148	ñ 164	‡ 180	— 196	⋈ 212	Σ 228	∫ 244
5	à 133	ò 149	ñ 165	‡ 181	† 197	ƒ 213	σ 229	∫ 245
6	ä 134	û 150	ä 166	‡ 182	ƒ 198	π 214	μ 230	÷ 246
7	ç 135	ù 151	ø 167	∩ 183	‡ 199	‡ 215	τ 231	≈ 247
8	ê 136	ÿ 152	¿ 168	‡ 184	⋈ 200	‡ 216	Φ 232	° 248
9	ë 137	ÿ 153	ƒ 169	‡ 185	∩ 201	∩ 217	Θ 233	• 249
A	è 138	ù 154	ƒ 170	‡ 186	⋈ 202	∩ 218	Ω 234	— 250
B	ï 139	¢ 155	½ 171	∩ 187	∩ 203	■ 219	ó 235	√ 251
C	î 140	£ 156	¼ 172	∩ 188	∩ 204	■ 220	∞ 236	∞ 252
D	ì 141	¥ 157	ı 173	∩ 189	= 205	■ 221	ø 237	² 253
E	Ë 142	ℳ 158	« 174	∩ 190	∩ 206	■ 222	ε 238	■ 254
F	À 143	f 159	» 175	∩ 191	⋈ 207	■ 223	∩ 239	■ 255

Family 3

All codes above 7Fh are undefined.

	0	1	2	3	4	5	6	7
0	<NUL> 0	16	32	48	64	80	96	112
1	1	<DC1> 17	33	49	65	81	97	113
2	2	<DC2> 18	34	50	66	82	98	114
3	3	<DC3> 19	35	51	67	83	99	115
4	4	<DC4> 20	36	52	68	84	100	116
5	5	21	37	53	69	85	101	117
6	6	22	38	54	70	86	102	118
7	<BEL> 7	23	39	55	71	87	103	119
8	<BS> 8	<CAN> 24	40	56	72	88	104	120
9	<HT> 9	 25	41	57	73	89	105	121
A	<LF> 10	26	42	58	74	90	106	122
B	<VT> 11	<ESC> 27	43	59	75	91	107	123
C	<FF> 12	<FS> 28	44	60	76	92	108	124
D	<CR> 13	29	45	61	77	93	109	125
E	<SO> 14	30	46	62	78	94	110	126
F	<SI> 15	31	47	63	79	95	111	 127

Family 4

	0	1	2	3	4	5	6	7	
0	<NUL> 0	16	32	48	@	P	`	p	
1	1	<DC1> 17	!	33	49	A	Q	a	q
2	2	<DC2> 18	"	34	50	B	R	b	r
3	♥	<DC3> 19	#	35	51	C	S	c	s
4	♦	<DC4> 20	\$	36	52	D	T	d	t
5	♣	§	%	37	53	E	U	e	u
6	♠		&	38	54	F	V	f	v
7	<BEL> 7	23	'	39	55	G	W	g	w
8	<BS> 8	<CAN> 24	(40	56	H	X	h	x
9	<HT> 9	 25)	41	57	I	Y	i	y
A	<LF> 10	26	*	42	58	J	Z	j	z
B	<VT> 11	<ESC> 27	+	43	59	K	[k	{
C	<FF> 12	<FS> 28	,	44	60	L	\	l	
D	<CR> 13	29	-	45	61	M]	m	}
E	<SO> 14	30	.	46	62	N	^	n	~
F	<SI> 15	31	/	47	63	O	_	o	

	8	9	A	B	C	D	E	F
0	A 128	P 144	ι 160	⋮ 176	⊥ 192	⊥ 208	ω 224	Ω 240
1	B 129	Σ 145	κ 161	⋮ 177	⊥ 193	⊥ 209	ά 225	± 241
2	Γ 130	Τ 146	λ 162	⋮ 178	⊥ 194	⊥ 210	έ 226	≥ 242
3	Δ 131	Υ 147	μ 163	 179	⊥ 195	⊥ 211	ή 227	≤ 243
4	E 132	Φ 148	ν 164	⊥ 180	— 196	⊥ 212	ϊ 228	∫ 244
5	Z 133	X 149	ξ 165	⊥ 181	⊥ 197	⊥ 213	ί 229	J 245
6	H 134	Ψ 150	ο 166	⊥ 182	⊥ 198	⊥ 214	ό 230	÷ 246
7	Θ 135	Ω 151	π 167	⊥ 183	⊥ 199	⊥ 215	ύ 231	≈ 247
8	I 136	α 152	ρ 168	⊥ 184	⊥ 200	⊥ 216	ϋ 232	° 248
9	K 137	β 153	σ 169	⊥ 185	⊥ 201	⊥ 217	ώ 233	£ 249
A	Λ 138	γ 154	ς 170	⊥ 186	⊥ 202	⊥ 218	Α 234	¥ 250
B	M 139	δ 155	τ 171	⊥ 187	⊥ 203	■ 219	Ε 235	√ 251
C	N 140	ε 156	υ 172	⊥ 188	⊥ 204	■ 220	Η 236	n 252
D	Ξ 141	ζ 157	φ 173	⊥ 189	= 205	■ 221	Ι 237	² 253
E	O 142	η 158	χ 174	⊥ 190	⊥ 206	■ 222	Ο 238	■ 254
F	Π 143	θ 159	ψ 175	⊥ 191	⊥ 207	■ 223	Υ 239	255

IBM CHARACTER SET #1

	0	1
0	<NUL> 0	16
1	<DC1> 1	17
2	<DC2> 2	18
3	<DC3> 3	19
4	<DC4> 4	20
5	5	21
6	6	22
7	<BEL> 7	23
8	<BS> 8	<CAN> 24
9	<HT> 9	 25
A	<LF> 10	26
B	<VT> 11	<ESC> 27
C	<FF> 12	<FS> 28
D	<CR> 13	29
E	<SO> 14	30
F	<SI> 15	31

	8	9
0	<NUL> 128	144
1	<DC1> 129	145
2	<DC2> 130	146
3	<DC3> 131	147
4	<DC4> 132	148
5	133	149
6	134	150
7	<BEL> 135	151
8	<BS> 136	<CAN> 152
9	<HT> 137	 153
A	<LF> 138	154
B	<VT> 139	<ESC> 155
C	<FF> 140	<FS> 156
D	<CR> 141	157
E	<SO> 142	158
F	<SI> 143	159

Other characters are identical to IBM character set #2.

The duplication of control codes enables systems with a 7-bit interface to obtain control functions when the most significant bit is set to 1 by the <ESC> “\” command.

ADDITIONAL CHARACTER SET

	0	1
0	∅	▶
1	⊕	◀
2	⊙	↓
3	♥	!!
4	♦	¶
5	♣	S
6	♠	-
7	•	⊥
8	◼	↑
9	○	↓
A	◻	→
B	♂	←
C	♀	└
D	♫	↔
E	♯	▲
F	✳	▼

In IBM mode, additional characters can be printed by special commands except the Family 3 (Code 39).

INTERNATIONAL CHARACTER SETS

When an international character set is selected DIP switches 4 to 7 or by a command from software, the following changes are made in the character set:

Country	23	24	40	5B	5C	5D	5E	60	7B	7C	7D	7E	9B	9D
U.S.A.	#	\$	@	[\]	^	'	{		}	~	ç	¥
FRANCE	#	\$	à	°	ç	§	^	'	é	ù	è	¨	ç	¥
GERMANY	#	\$	§	Ä	ö	ü	^	'	ä	ö	ü	ß	ç	¥
ENGLAND	£	\$	@	[\]	^	'	{		}	~	ç	¥
DENMARK 1	#	\$	@	Æ	Ø	Å	^	'	æ	ø	å	~	ç	¥
SWEDEN	#	¤	É	Ä	Ö	Å	Û	É	Ä	Ö	Å	Ü	Ç	¥
ITALY	#	\$	@	°	\	é	^	ù	à	ò	è	ì	ç	¥
SPAIN 1	₧	\$	@	í	ñ	¿	^	'	¨	ñ	}	~	ç	¥
JAPAN	#	\$	@	[¥]	^	'	{		}	~	ç	¥
NORWAY	#	¤	É	Æ	Ø	Å	Û	É	æ	ø	å	ü	ç	¥
DENMARK 2	#	\$	É	Æ	Ø	Å	Û	É	æ	ø	å	ü	ç	¥
SPAIN 2	#	\$	á	í	ñ	¿	é	'	í	ñ	ó	ú	ç	¥
LATIN AMERICA	#	\$	á	í	ñ	¿	é	ü	í	ñ	ó	ú	ç	¥
DENMARK/NORWAY	#	\$	@	[\]	^	'	{		}	~	ø	ø

See Chapter 5 for the DIP switch settings.

The commands for selecting the international character sets are:

Standard mode: <ESC> "R" *n* IBM mode: <FS> "R" *n*

Where *n* means character code *n*, i.e. CHR\$(*n*) in BASIC. The values of *n* are:

- | | | |
|-------------|-----------|-------------------|
| 0 U.S.A. | 5 Sweden | 10 Denmark II |
| 1 France | 6 Italy | 11 Spain II |
| 2 Germany | 7 Spain I | 12 Latin America |
| 3 England | 8 Japan | 13 Denmark/Norway |
| 4 Denmark I | 9 Norway | |

MEMO

INDEX

A

- Application software installation, 93
- ASF, 1, 20
 - Troubleshooting, 79
- Auto CR, 21
- Auto LF, 21
- Auto loading, 20
 - ASF, 20
- Auto on-line, 19
- Automatic sheet feeder - see ASF

B

- BASIC programming, 96, 103
- Bidirectional printing, 19
- Bidirectional test mode, 90
- Buffer clear/reset, 16

C

- Character sets, 109
- Character set, 73, 74
- Cleaning, 81
- Command codes, 24
- Command menu, 19
- Condensed print, 20
- Connection to computer, 5
- Continuous stationery - See Fanfold paper
- Controls, 11
- Cut-sheet paper, 7

D

- Default settings, 22
- Diagnostic and test modes, 86
- DIP switches, 73
 - Location, 6
- Draft-12, 20
- Draft mode, 12

E

- Emulation, 23, 73, 74
- Environment, 1
- Epson mode - see Standard mode
- Escape sequence example, 25
- Escape sequences, 24

F

- Factory settings, 22
- Fanfold paper, 8
 - Short tear-off function, 15
- Font panel lock, 13
- Font selection, 13
- Form feed, 14
- Front panel controls, 11

G

- Graphics direction, 19
- Graphics dump, 95

H

- Hexadecimal conventions, 23
- Hexadecimal dump mode, 89
- High-speed/high density printing, 20

I

- IBM mode, 23
- Indicators, 11
- International character sets, 74, 129
- Italic printing, 20

L

- Letter Quality mode - see LQ mode
- Lines per inch, 21
- LQ mode, 12

M

Maintenance settings, 16
Maintenance, 81
Maximum number of columns, 94,106
Memory switches, 17
 Memory switch tree, 18,88
Micro Feed, 16
Mode panel lock, 13
Mode setting, 12

N

Negative numbers, 23
Numerical representation, 23

O

Option ASF, 20

P

Page length, 21,73
Paper
 Cut-sheet, 7
 Fanfold, 8
 Parking, 14
 Size, 21,73
Paper feeding, troubleshooting, 78
Paper menu, 20
Paper out detector, 20
Parallel interface, 15,108
Patches for BASIC interpreter, 103
Pinwriter mode - see Standard mode
Pitch panel lock, 12
Pitch setting, 12,20
Platen knob, fitting, 3
Power supply, troubleshooting, 76
Print head replacement, 84
Print menu, 20
Print quality, 20
Printing, troubleshooting, 76
Printing gap adjustment, 81
Prorprinter mode - see IBM mode

Q

Quality setting - see Mode setting
Quiet mode, 11,14,19

R

RAM usage, 19
Ribbon installation, 4,82
RS232 interface, 1

S

Setting up from DOS, 95
Short tear-off (Memory Switches), 21
Short tear-off function, 15
 Skip over perforation, 21
Slashed zero, 19
SLQ
 Font style, 19
 SLQ Mode, 12
Specifications, 105
Spreadsheet installation, 94
Standard mode, 23
Super Letter Quality mode - see SLQ mode

T

Test mode
 Long, 87
 Short, 86
 Text, 88
Test settings, 16
Troubleshooting, 75

U

Unidirectional printing, 19
Unpacking, 1,3

V

Vertical pitch, 21

Z

Zero style, 19

Free Manuals Download Website

<http://myh66.com>

<http://usermanuals.us>

<http://www.somanuals.com>

<http://www.4manuals.cc>

<http://www.manual-lib.com>

<http://www.404manual.com>

<http://www.luxmanual.com>

<http://aubethermostatmanual.com>

Golf course search by state

<http://golfingnear.com>

Email search by domain

<http://emailbydomain.com>

Auto manuals search

<http://auto.somanuals.com>

TV manuals search

<http://tv.somanuals.com>