

STIGA COMPACT LINE

SNOW ELECTRIC

BRUKSANVISNING	SV	4
KÄYTTÖOHJEET	FI	8
BRUGSANVISNING	DA ..	12
BRUKSANVISNING	NO ..	16
GEBRAUCHSANWEISUNG	DE...	20
INSTRUCTIONS FOR USE	EN...	24
MODE D'EMPLOI	FR....	28
ISTRUZIONI PER L'USO	IT.....	32
INSTRUKCJA OBSŁUGI	PL....	36
ИНСТРУКЦИЯ ПОЛЬЗОВАТЕЛЯ	RU...	40
NÁVOD K POUŽITÍ	CS...	45
HASZNÁLATI UTASÍTÁS	HU ..	49
NAVODILA ZA UPORABO	SL	54

8218-2218-71



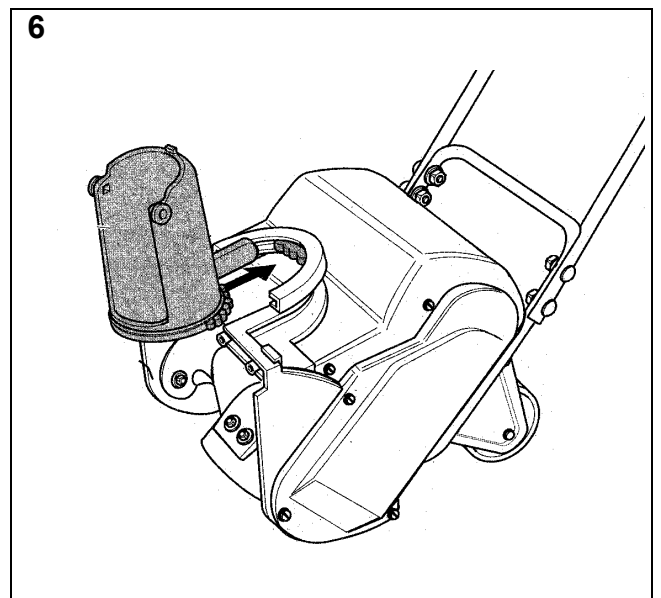
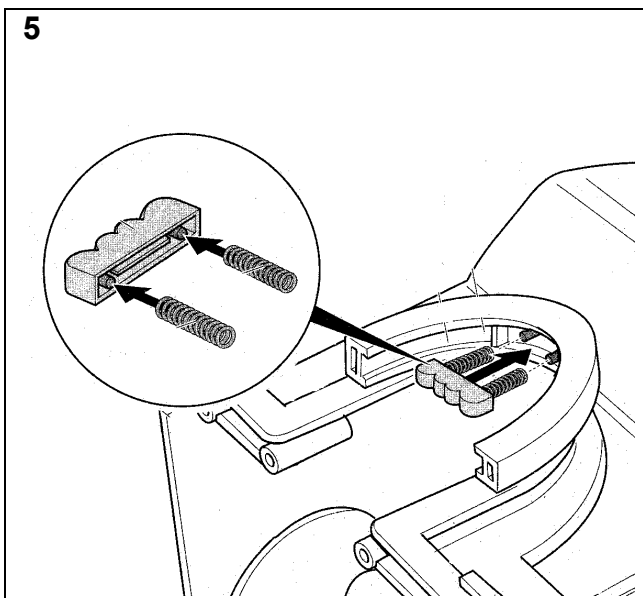
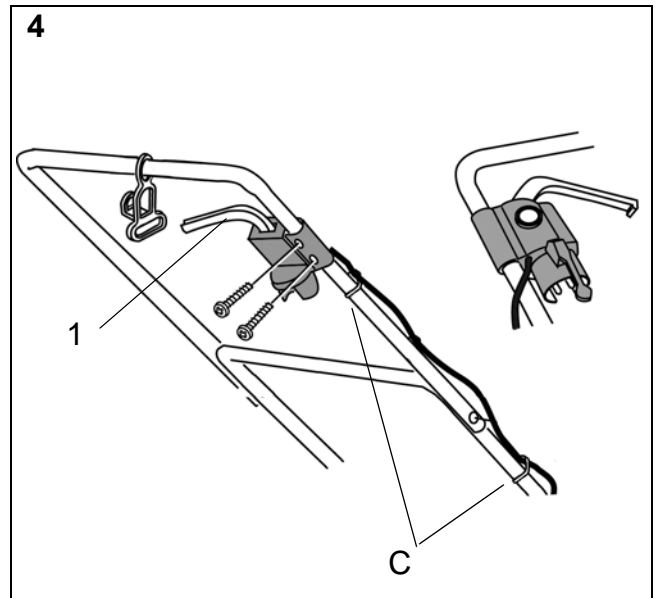
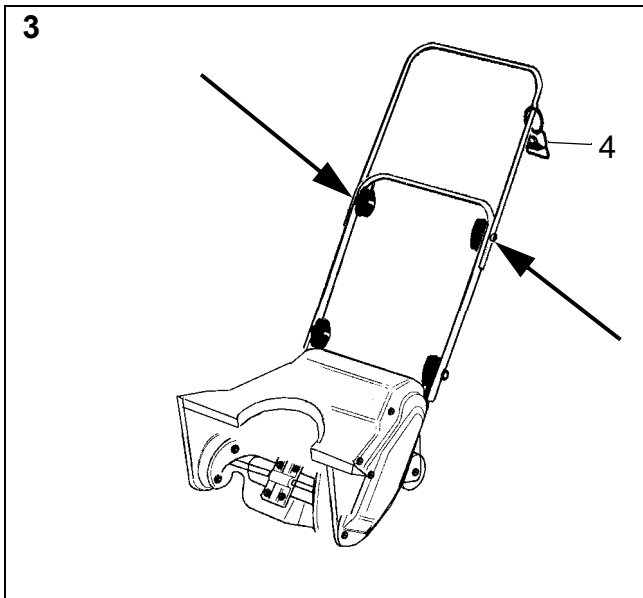
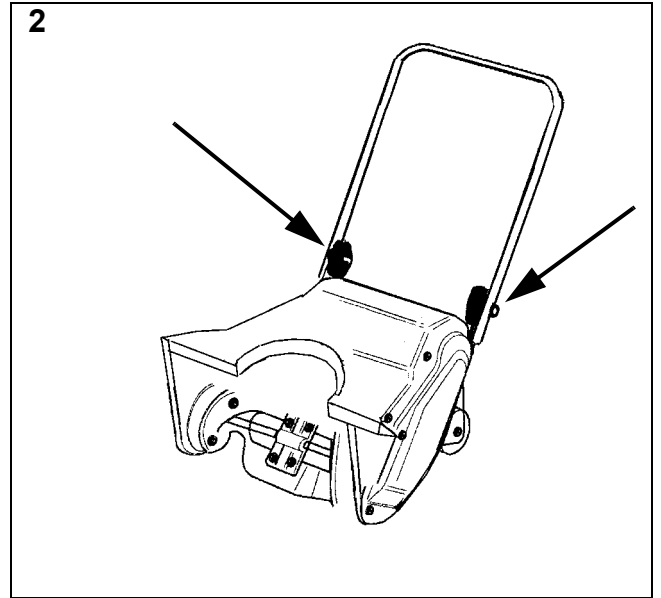
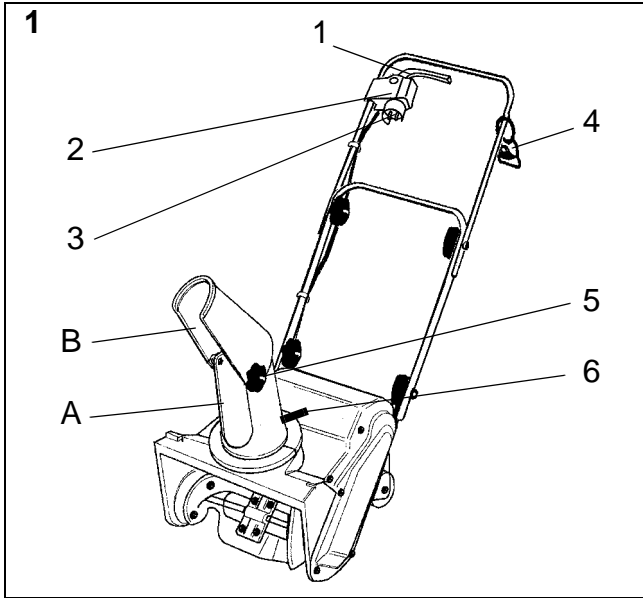

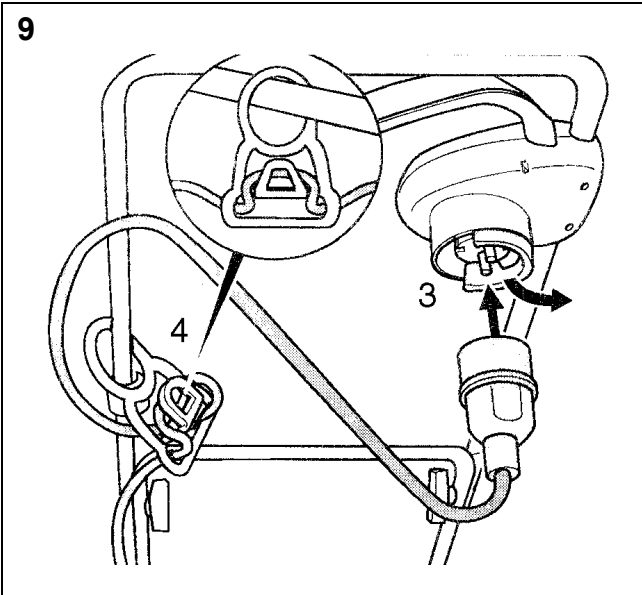
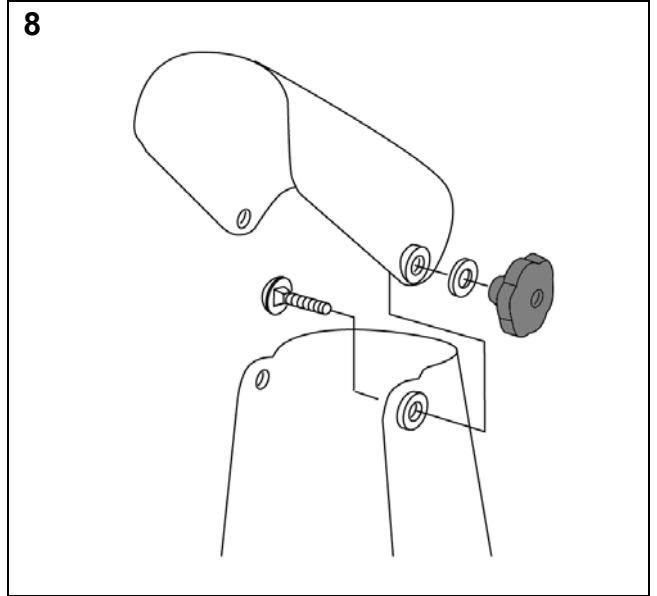
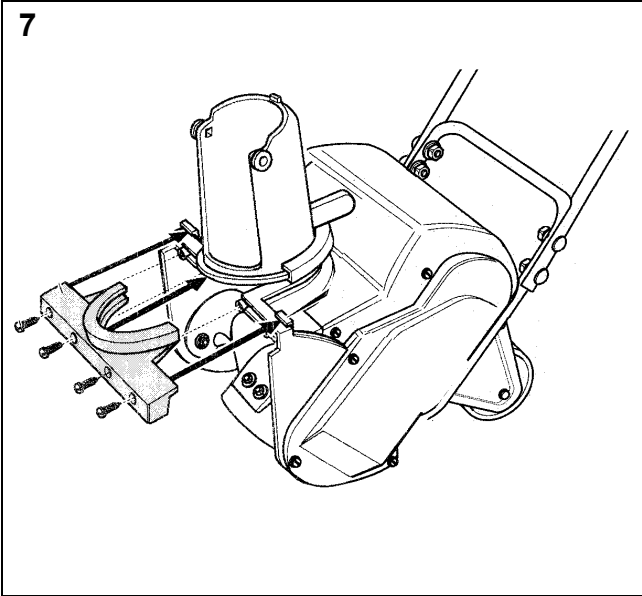

1 SYMBOLS

The following symbols appear on the machine. They are there to remind you of the care and attention required in use. This is what the symbols mean:



Warning. If the regulations are not followed, there is a risk of danger to life and machine breakdown.



Read the owner's manual before operating the machine.



Keep bystanders at a safe distance from the machine.



Warning of hard objects flying off.



The power supply must be disconnected before carrying out cleaning or maintenance. Shut off the motor before unclogging the discharge chute.



The electric cable must be kept away from the auger opening. Check that the connection cable is always fault free. Only fault-free cables may be used.



Keep hands and feet away from rotating parts. Risk of death and maiming. Avoid injury from the rotating auger, keep hands, feet and clothing away.



Risk of fatal electric shocks

2 SAFETY INSTRUCTIONS

2.1 GENERAL

- Please read through these instructions carefully. Learn all the controls and the correct use of the machine.
- Never allow children or anyone who is not familiar with these instructions to use the snow thrower. Local regulations may impose restrictions as regards the age of the driver.
- Never use the machine if others, particularly children or animals, are in the vicinity.
- Remember that the driver is responsible for accidents that happen to other people or their property.
- Be careful not to trip or fall, especially when reversing the machine.
- Never use the snow thrower under the influence of alcohol or medication and if you are tired or ill.

2.2 PREPARATIONS

- Check the area to be cleared and remove any loose or foreign objects.
- Disengage all controls before starting the engine.
- Never use the snow thrower unless properly dressed. Wear footwear that improves your grip on a slippery surface.
- Adjust the height of the auger housing to ensure it stays above gravel paths.
- Check that the mains voltage corresponds with the snow thrower's rated voltage.

- Never, under any circumstances, make adjustments while the engine is running (unless otherwise specified in the instructions).
- Allow the snow thrower to adjust to the outdoor temperature before using it.
- Always use protective goggles or a visor during use, maintenance and service.

2.3 OPERATION

- Keep hands and feet away from rotating parts. Always avoid the discharge chute opening.
- Be careful when driving on or crossing gravel paths, pavements and roads. Be aware of hidden dangers and traffic.
- Never direct the discharge chute towards a public road or traffic.
- If the snow thrower hits a foreign object, stop the engine, disconnect and carefully inspect the machine for damage. Repair the damage before using the machine again.
- If the machine starts vibrating abnormally, stop the engine and look for the cause. Vibration is normally a sign of something wrong.
- The snow thrower may only be connected to power sockets that are supplied with earth leakage circuit breakers. The earth leakage circuit breaker must have a trip current of max. 30 mA.
- Risk of tripping over the electric cable. Always be aware of the whereabouts of the electric cable so that it does not get in the way of your feet or anything else moving about in the area.
- The snow thrower may only be connected with a cable that is approved for outdoor use.
- The electric cable with which the snow thrower is connected must always be intact. It must never be used if it displays signs of damage.
- The snow thrower must never be used if its plug, electric cable or other electrical equipment is damaged.
- Repairs to the electrical equipment may only be carried out by an authorised electrician.
- Never drive over the electric cable for the snow thrower while working.
- If the electric cable for the snow thrower has been damaged while working, the following instructions must be followed:
 - A. Stop the motor.
 - B. Leave the site in the opposite direction from the damaged point on the cable.
 - C. Disconnect the cable from the power socket.
- Stop the motor and disconnect the power supply:
 - A. If the driver leaves the machine.
 - B. If the auger housing or discharge chute is blocked and must be cleaned.
 - C. Before beginning repairs or adjustments.
- Stop the engine and disconnect the spark plug cable:
 - A. If the machine steers away from the driving position.
 - B. If the auger housing or discharge chute is blocked and must be cleaned.
 - C. Before beginning repairs or adjustments.

- Always make sure the rotating parts have stopped and all the controls are disengaged before cleaning, repairing or inspection.
- Before leaving the machine unattended, disengage all the controls, put it into neutral gear, stop the engine and remove the ignition key.
- Never run the engine indoors except when taking it in and out of its place of storage. In this case ensure the door to the storage place is open. Exhaust fumes are toxic.
- Never drive across a slope. Move from the top down, and from the bottom to the top. Be careful when changing direction on a slope. Avoid steep slopes.
- Never operate the machine with insufficient protection or without the safety devices in place.
- Existing safety devices must not be disconnected or disengaged.
- Do not alter the engine's regulator setting and do not race the engine. The possibility of personal injury increases when the engine is run at high revs.
- Never use the snow thrower near enclosures, cars, windowpanes, slopes etc. without properly setting the discharge chute deflector.
- Always keep children away from areas to be cleared. Get another adult to keep the children under supervision.
- Do not overload the machine by driving it too fast.
- Take care when reversing. Look behind you before and during reversing to check for any obstacles.
- Never point the discharge chute towards bystanders. Do not allow anyone to stand in front of the machine.
- Disengage the auger when the snow thrower is to be transported or is not in use. Do not drive too fast on slippery surfaces when transporting.
- Only use accessories that are approved by the machine's manufacturer.
- Never drive the snow thrower in bad visibility or without satisfactory lighting.
- Always ensure you have a good balance and a tight grip on the handle.
- Never use the snow thrower on a roof.
- Do not touch engine components because they are warm during use. Risk of burn injuries.

2.4 MAINTENANCE AND STORAGE

- Tighten all nuts and screws so that the machine is in safe working condition. Check the shear bolts regularly.
- Always use genuine spare parts. Non-genuine spare parts can entail a risk of injury, even if they fit the machine.
- Never store the machine with petrol in the tank in buildings where the fumes can come into contact with open flames or sparks.
- Allow the engine to cool before putting the machine in store.
- Before a long storage, check the instructions for recommendations.
- Replace damaged warning and instruction stickers.
- Let the engine run a couple of minutes with the auger connected after use. This prevents the auger from freezing solid.

3 ASSEMBLY

3.1 UNPACKING

1. Open the packing and take out all parts.
2. Check that all parts are supplied. The parts are as follows:
 - Lower part of the handle
 - Upper part of the handle
 - Start control
 - Cable holder
 - Six black knobs.
 - Four long screws with square fittings.
 - Two short screws with square fittings.
 - Four screws with washers for the chute attachment.
 - Chute attachment.
 - Ratchet with springs for the chute.
 - Chute.
 - Two plane washers for the deflector.
 - Deflector.
 - Cable holders
 - Two clamps for fixing of the cable.
 - Two screws for the start control.
3. If anything is missing or damaged, take immediately contact with the supplier.

3.2 HANDLE

3.2.1 Lower part of the handle

See fig. 2.

Assemble the lower part of the handle with two knobs and two long screws with square fittings.

3.2.2 Upper part of the handle

See fig. 3.

Assemble the cable holder (4) to the upper part of the handle. Assemble the upper part of the handle on the lower part of the handle. Fix with two long screws with square fittings and two knobs.

3.2.3 Start control

See fig. 4.

Assemble the start control (1) on the upper part of the handle. Secure the cable to the handle with two clamps (C).

3.2.4 Chute

1. Assemble the ratchet with the two springs. See fig. 5.
2. Assemble the chute in the opening and against the ratchet. See fig. 6.
3. Assemble the chute attachment with four screws and four washers. See fig. 7.
4. Assemble the deflector with two short screws, two washers and two knobs. See fig. 8.

4 CONTROLS

The snow thrower is fitted with the following controls and devices.

See fig. 9-12.

Starting handle (1) – Starts and stops the electric motor.

Ignition lock (2) – Facilitates activation of the starting handle.

Connector (3) – For electrical connection.

Cable support (4) – For supporting the connection cable.

Deflector lock (5) – Locks the deflector in position.

Direction lever (6) – Changes the direction of the discharge chute.

Discharge chute (A) – Ejects the snow.

Deflector (B) – Determines the distance the snow is thrown.

5 USING THE MACHINE

5.1 GENERAL

Never start the engine until all the above measures under 'ASSEMBLY' have been carried out.



Never use the snow thrower without first reading and understanding the enclosed instructions and all the warning and instruction stickers on the snow thrower and in these instructions.



Always wear protective goggles or a visor during use, maintenance and service.

5.2 BEFORE STARTING



The connection cable and its plugs must be fault free and approved for outdoor use.



The connection cable may only be connected to power sockets equipped with an earth leakage circuit breaker with a trip current of max. 30 mA.



The connection cable must be suspended on the cable support. Otherwise there is a risk of damage alongside the plug which is potentially life-threatening.

Connect the snow thrower with the electric cable from the property's power socket.

Suspend the cable on the cable support (4) and connect to the connector (3). See fig. 9.

5.3 START

Start the motor and the auger as described below.

See fig. 1.

1. Lean the snow thrower back slightly so that the auger is raised a little above the ground.
2. Press in and hold the button (2). Squeeze the handle (1).
3. Release the ignition lock, lower the auger towards the ground and start to clear the snow.

5.4 STOP

Stop the motor and the auger by releasing the starting handle (1). See fig. 1.

5.5 SNOW CLEARANCE

See fig. 1.



Never aim the snow at bystanders.



Always stop the engine before unclogging.



Always wear eye protection when operating the snow thrower.



If the auger is blocked, never try to keep the motor engaged for more than 20 seconds. Extensive engagement will damage the motor.

1. Start the motor as described above and check the ejection distance and direction.
2. If necessary, stop the motor and adjust the deflector (B). Upwards gives a longer throwing distance and downwards gives a shorter throwing distance. Lock the deflector in position using the knob (5).
3. If necessary, stop the motor and adjust the discharge chute (A) with the lever (6) so that the snow is ejected in the desired direction.
4. Stop working by releasing the starting handle (1).
5. Any unclogging can easily be carried out with a piece of wood or similar after the engine has stopped.

The snow thrower is propelled automatically with the aid of the auger. To facilitate propulsion, raise the handlebar a little. Do not push the snow thrower.

5.5.1 Dry and normal snow

Snow up to 20 cm deep can be removed quickly and easily by clearing at an even speed. Plan for downwind discharge of the snow.

5.5.2 Wet, packed snow

Drive slowly forward. If the wet, packed snow blocks the discharge chute, back up and jab a little way into the snow a few times to clear the deflector.

5.6 AFTER USE



The snow thrower must never be rinsed with water. Risk of damage to the electrical system and risk of electric shocks.

1. Stop the motor.
2. Disconnect the electric cable from the snow thrower and the property's power socket.
3. Allow the snow thrower to cool for 30 minutes.
4. Clean the inside and outside of the snow thrower with a suitable brush.
5. Check that there are no damaged or loose parts. Repair/replace parts if necessary.

6 MAINTENANCE



The electrical connection must be disconnected before carrying out maintenance work.

6.1 BEFORE USE

- Every time the snow thrower is to be used, check that the electrical equipment is intact and free of faults. The snow thrower must not be used if there are any faults or if anything is missing.
- Check that the auger rotates easily.
- Check that all screw joints are tightened. Tighten if necessary.
- Apply silicon spray to the auger. This prevents icing.
- Check that the starting handle cannot be activated without the ignition lock being moved to the left.

6.2 FAULT-TRACING

The faults described below can usually be rectified directly by the user. If there is any doubt, contact an authorised agent.

The motor does not start:

- The electric cable is not connected or is defective.
- The fuse has blown. If a higher amp fuse needs to be installed, contact an authorised electrician.

The motor hums, but does not start:

- Auger or discharge chute blocked.
- The capacitor is defective. Contact your GGP agent.

The motor stops suddenly:

- Loose plugs.
- The overload protection has been tripped. Wait for 10 minutes, then attempt to start again.

The snow thrower vibrates:

- Loose parts.
- Defective auger.
- The motor is loose.

The snow thrower does not clear any snow:

- Auger or discharge chute blocked.

The drive belt is loose or defective.

7 STORAGE

When the snow thrower is to be stored for an extended period, such as during that part of the year when snow clearance does not need to be carried out, the following measures must be taken.

1. Clean the whole snow thrower thoroughly.
2. Inspect the snow thrower for damage. Repair if necessary.
3. Touch up any paint damage.
4. Rust-proof unpainted metal surfaces.
5. Store the snow thrower in a clean, dry place.

8 PURCHASE TERMS

A full warranty is issued against manufacturing and material defects. The user must carefully follow the instructions given in the enclosed documentation.

The warranty does not cover damage due to:

- Neglect by users to acquaint themselves with accompanying documentation
- Carelessness
- Incorrect and non-permitted use or assembly
- The use of non-genuine spare parts
- The use of accessories not supplied or approved by GGP

Neither does the warranty cover:

- Wear parts such as drive belts, augers, wheels
- Normal wear
- Engines. These are covered by the engine manufacturer's warranties, with separate terms and conditions.

The purchaser is covered by the national laws of each country. The rights to which the purchaser is entitled with the support of these laws are not restricted by this warranty.



www.stiga.com

GGP Sweden AB · Box 1006 · SE-573 28 TRANÅS

Free Manuals Download Website

<http://myh66.com>

<http://usermanuals.us>

<http://www.somanuals.com>

<http://www.4manuals.cc>

<http://www.manual-lib.com>

<http://www.404manual.com>

<http://www.luxmanual.com>

<http://aubethermostatmanual.com>

Golf course search by state

<http://golfingnear.com>

Email search by domain

<http://emailbydomain.com>

Auto manuals search

<http://auto.somanuals.com>

TV manuals search

<http://tv.somanuals.com>