



Professional Quadraphonic DJ Mixer

PMC-07Pro ISP

OWNER'S MANUAL

VESTAX CORPORATION

1-18-6 Wakabayashi, Setagaya-ku, Tokyo 154-0023 Japan
Phone:03-3412-7011 Fax:03-3412-7013

VESTAX America

2750C 29th Ave Suite. 115 Hollywood, FL33020
Phone:303-766-5269 Fax:303-766-2196

VESTAX (Europe)Ltd.

18 st.Christophers Road, Haslemere,Surrey GU 27 1 DQ England.
Phone:(0)1428-653117 Fax:(0)1428-661021

CONGRATULATIONS!

Thank you for purchasing the VESTAX PMC-07ProISP, Professional Quadraphonic DJ Mixer. Please read this owner's manual carefully before you start to use your mixer in order to fully understand all of the special features.

CONTENTS

C A U T I O N	1
IMPORTANT SAFEGUARDS	2
F E A T U R E S	3
F U N C T I O N S	4
HOW TO CHANGE THE FADER UNIT	8
CONNECTION DIAGRAM	9
CHAIN CONNECTION	10
BLOCK DIAGRAM	12
I . S . P M O D E L	13
SPECIFICATIONS	14



CAUTION

RISK OF ELECTRIC SHOCK DO NOT OPEN



**CAUTION : TO REDUCE THE RISK OF ELECTRIC SHOCK
DO NOT REMOVE COVER (OR BACK)
NO USER-SERVICEABLE PARTS INSIDE
REFER SERVICING TO QUALIFIED SERVICE PERSONNEL**



The lightning flash with arrowhead symbol, within an equilateral triangle, is intended to alert the user to the presence of uninsulated "dangerous voltage" within the product's enclosure that may be of sufficient magnitude to constitute a risk of electric shock to persons.



The exclamation point within an equilateral triangle is intended to alert the user to the presence of important operating and maintenance (servicing) instructions in the literature accompanying the appliance.

**TO REDUCE THE RISK OF FIRE OR ELECTRIC SHOCK, DO NOT
EXPOSE THIS APPLIANCE TO RAIN OR MOISTURE.**

IMPORTANT SAFEGUARDS

READ BEFORE OPERATING EQUIPMENT

This product was designed and manufactured to meet strict quality and safety standards. There are, however, some installation and operation precautions which you should be particularly aware of.

1. Read instructions-All the safety and operating instructions should be read before the appliance is operated.
2. Retain instructions-The safety and operating instructions should be retained for future reference.
3. Heed Warnings-All warnings on the appliance and in the operating instructions should be adhered to.
4. Follow Instructions-All operating and use instructions should be followed.
5. Cleaning-Do not use liquid cleaners or aerosol cleaners. Use a damp cloth for cleaning.
6. Attachments-Do not use attachments not recommended by the product manufacturer as they may cause hazards.
7. Water and Moisture-Do not use this product near water-for example, near a bath tub, wash bowl, kitchen sink, or laundry tub, in a wet basement, or near a swimming pool, and the like.
8. Accessories-Do not place this product on an unstable cart, stand, tripod, or table. The product may fall, causing serious injury to a child or adult, and serious damage to the appliance. Use only with a cart, stand, tripod, bracket, or table recommended by the manufacturer, or sold with product. Any mounting of the appliance should follow the manufacturer's instructions, and should use a mounting accessory recommended by the manufacturer.
9. This product should never be placed near or over a radiator or heat register. This product should not be placed in a built-in installation such as a bookcase or rack unless proper ventilation is provided or the manufacturer's instructions have been adhered to.
10. Power sources-This product should be operated only from the type of power source indicated on the marking label. If you are not sure of the type of power supply to your home, consult your appliance dealer or local power company.
11. Lightning-For added protection for this product during lightning storm, or when it is left unattended and unused for long periods of time, unplug it from the wall outlet. This will prevent damage to the product due to lightning and power-line surges.
12. Overloading-Do not overload wall outlets and extension cords as this can result in a risk of fire or electric shock.
13. Object and Liquid Entry-Never push objects of any kind into this product through openings as they may touch dangerous voltage points or short-out parts that could result in a fire or electric shock. Never spill liquid of any kind on the product.
14. Servicing-Do not attempt to service product yourself as opening or removing covers may expose you to dangerous voltage or other hazards. Refer all servicing to qualified personnel.

-
15. **Damage Requiring Service**-Unplug this product from the wall outlet and refer servicing to qualified service personnel under the following conditions:
 - a. When the power-supply cord or plug is damaged.
 - b. If liquid has been spilled or objects have fallen into the product.
 - c. If the product has been exposed to rain or water.
 - d. If the product does not operate normally by following the operating instructions. Adjust only those controls that are covered by the operating instructions as an improper adjustment of other controls may result in damage and will often require extensive work by a qualified technician to restore the product to its normal operation.
 - e. If the product has been dropped or cabinet has been damaged.
 - f. When the product exhibits a distinct change in performance-this indicates need for service.
 16. **Replacement Parts**-When replacement parts are required, be sure the service technician has used replacement parts specified by the manufacturer or have the same characteristics as the original parts. Unauthorized substitutions may result in fire, electric shock or other hazards.
 17. **Safety Check**-Upon completion of any service or repairs to product, ask the service technician to perform safety checks to determine that the product is in proper operating condition.
 18. **Carts and Stands**-The appliance should be used only with a cart stand that is recommended by manufacturer.
 19. An appliance and cart combination should be moved with care. Quick stops, excessive force, and uneven surfaces may cause the appliance and cart combination to overturn.



FEATURES

- The world's first quadraphonic (4channel) output allows DJs to expand their performance to 3D level.
- Q-stick controls the dimension of each input source amongst four speakers. The beats and scratches fly around the room front, back, left and right.
- Effect send volume controls are provided to each program. Effect return can be assigned to each program or the master enabling various flying effects. Effect return is also equipped with a dedicated two band equalizer.
- Master trim volume lets DJs "Crab Scratch" on master fader.
- Crossfader and Inputfader status (reverse or normal) is indicated in meter section.
- Input jacks are provided specially only for "SESSION IN" and "PHONO IN" which is required by I.S.P.
- A 3-band EQ is provided on each program. The adjustment range(+6dB to -24dB) enables equalization and frequency elimination.
- Vestax invented the crossfader reverse switch and curve control and provided this feature for input faders as well. All faders are "photo coupler" to provide quicker response and longevity.
- Master / Cue select switch is provided to enable monitoring of cue source or master output signal.
- Master output is equipped with balanced 1/4 inch connectors for accurate sound integrity and durability.

FUNCTIONS

TOP PANEL SECTION

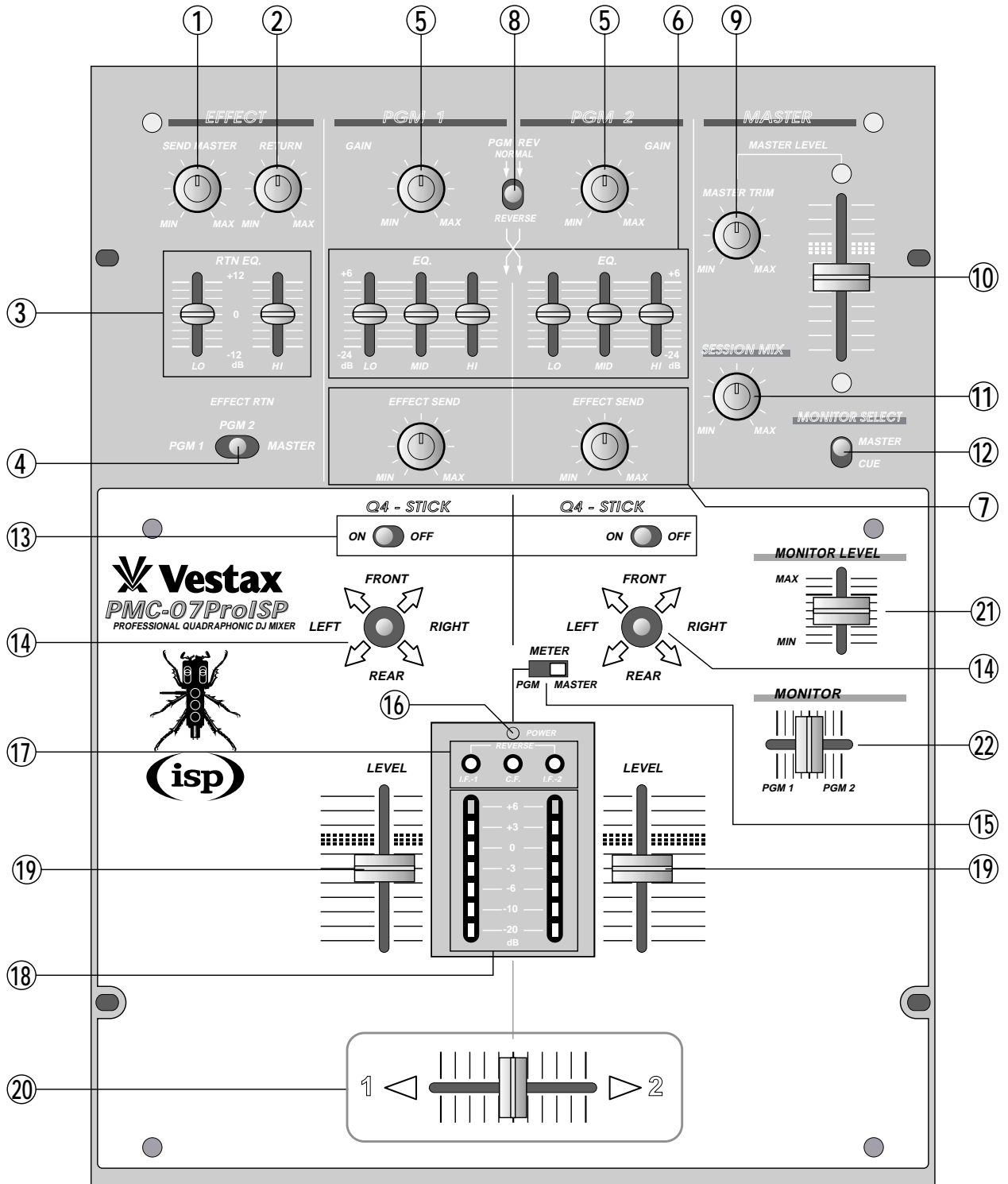

-
- ① **EFFECT SEND MASTER VOLUME**
Adjusts the output level of the EFFECT SEND.
 - ② **EFFECT RETURN VOLUME**
Adjusts the input level from the EFFECT RETURN.
 - ③ **EFFECT RETURN EQUALIZER**
HI and LO frequency adjustment of effects signal.
 - ④ **EFFECT RETURN ASSIGN SWITCH**
The switch selects return point of effects.
PGM1.....Assigns effects to the Q-stick on PGM1.
PGM2.....Assigns effects to the Q-stick on PGM2.
MASTER.... Assigns effects to pre-master fader.
 - ⑤ **PROGRAM GAIN VOLUME**
Adjusts the input level of each program. The INPUT LEVEL METER (18) should be at 0dB when the INPUT FADER (19) is at 7 or 8 position.
 - ⑥ **3 BAND EQUALIZER**
Adjusts HI, MID and LO frequencies on each program.
 - ⑦ **PROGRAM EFFECT SEND VOLUME**
Adjusts the send level for each program individually. When this volume is minimum, the same effect is off.
 - ⑧ **PROGRAM REVERSE SWITCH**
Switches PGM1 and 2 simultaneously.
 - ⑨ **MASTER TRIM VOLUME**
Trim adjustment for master level fader.
 - ⑩ **MASTER FADER**
Adjusts overall master output level.
 - ⑪ **SESSION MIX VOLUME**
Adjusts the input level of SESSION IN JACKS (35, 36).
 - ⑫ **MONITOR SELECT SWITCH**
This allows monitoring of the MASTER OUT (31, 32) or the CF MONITOR (22).
 - ⑬ **Q-STICK ON/OFF SWITCH**
When this switch is on, the Q-stick functions. When this switch is off, the Q-stick does not function.
 - ⑭ **Q-STICK(Quadraphonic Stick)**
Controls the volume sent to the four speakers or zones.
 - ⑮ **METER SELECT SWITCH**
Selection for LED to represent each program or the level of the master output.
 - ⑯ **POWER LED**
Illuminates when power is on.
 - ⑰ **FADER REVERSE LED**
Illuminates when respective faders are in reverse mode.
 - ⑱ **LED LEVEL METER**
Displays level of signal for each program or master out (determined by METER SELECT SWITCH (15)).
 - ⑲ **IF (INPUT FADER)**
This faders controls level of input signal for each program. This fader is easily replaced by user. Use IF-07PCV or IF-07PRO as replacements. See "HOW TO CHANGE THE FADER UNIT".
 - ⑳ **CF (CROSS FADER)**
Used to mix sound between PGM1 and 2, also detachable and easily replaced with CF-05PCV or CF-05PRO.
 - ㉑ **MONITOR LEVEL FADER**
Controls level in headphones.
 - ㉒ **CF MONITOR**
Crossfades signal to be monitored from each program.

FRONT PANEL SECTION

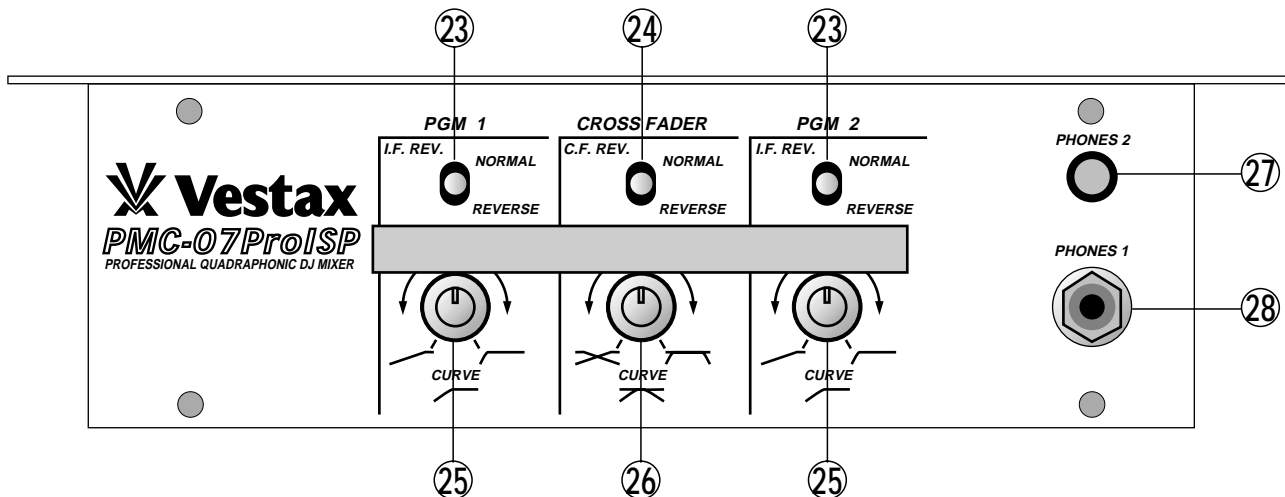

②③ IF REVERSE SWITCH

Reverses the action of the input fader by making the zero point top instead of bottom. Reverse mode is indicated in LED section.

②④ CF REVERSE SWITCH

Reverses the action of the crossfader by switching PGM1 and 2. Reverse mode is indicated in LED section.

②⑤ IF CURVE SELECT VOLUME

Adjusts the input fader curve for steep or gentle slope.

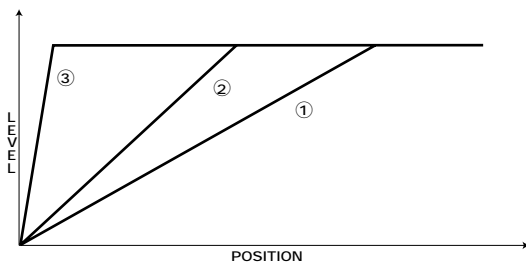

Rotate clockwise this volume,
I.F curve changes like a chart (① → ② → ③)

fig.A INPUT FADER CURVE

②⑥ CF CURVE SELECT VOLUME

Determines the slope characteristics of the crossfader's curve from steep to gradual.

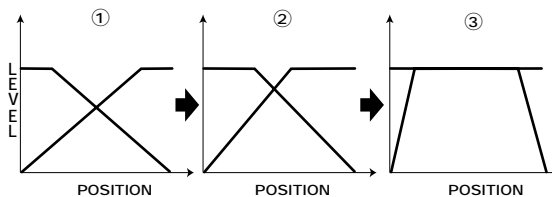

Rotate clockwise this volume,
C.F curve changes like a chart (① → ② → ③)

fig.B CROSS FADER CURVE

②⑦ MINI HEADPHONE JACK [ϕ 3.5]

Connect headphones with 1/8" mini headphone plug.

②⑧ HEADPHONE JACK [ϕ 6.3]

Connect headphones with a standard 1/4" stereo plug.

REAR PANEL SECTION

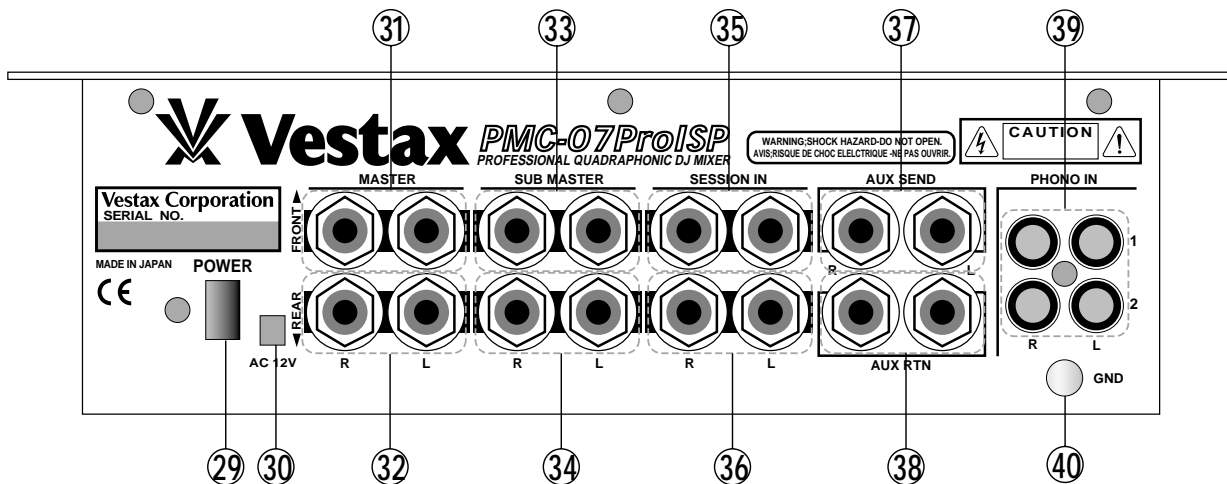

29 POWER SWITCH

Power for mixer, on status indicated by POWER LED(16) on top panel; should be turned on after all connections are made.

Note

As a general rule for protection, the amp should be turned on last and turned off first.

30 AC POWER JACK

Connect AC ADAPTOR (AC-12A) in here before switching on power.

Note

UNAUTHORIZED POWER ADAPTORs MAY CAUSE HARM TO UNIT.

31 MASTER OUT JACK-FRONT [1/4 inch TRS balanced]

Main output jacks for front left and front right speaker zones. Connect to power amp or crossover.

32 MASTER OUT JACK-REAR [1/4 inch TRS balanced]

Main output jacks for rear left and rear right speaker zones. Connect to power amp or crossover.

Note

These connectors are Tip=hot, Ring=cold, Sleeve=ground.

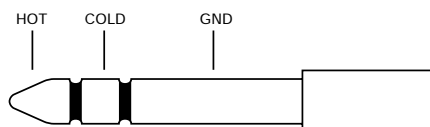

fig.C T.R.S JACK

33 SUB MASTER OUT JACK-FRONT [1/4 inch PHONE JACK unbalance]
Sub output jack for front left and front right speaker zone. Unbalanced connectors at -4dBm for monitoring etc.

34 SUB MASTER OUT JACK-REAR [1/4 inch PHONE JACK unbalance]
Sub output jack for rear left and rear right speaker zone. Unbalanced connectors at -4dBm for monitoring etc.

35 SESSION IN JACK-FRONT [1/4 inch PHONE JACK]
Allows front 1/4 inch chain connection with multiple PMC-07ProISP mixers.

36 SESSION IN JACK-REAR [1/4 inch PHONE JACK]
Allows rear 1/4 inch chain connection with multiple PMC-07ProISP mixers.

Note

See "CHAIN CONNECTION DIAGRAM" of page 10.

37 AUX SEND JACK [1/4 inch PHONE JACK]
Connect to the input of external effects. (delay, reverb etc.)

38 AUX RETURN JACK [1/4 inch PHONE JACK]
Connect to the output of external effects . (delay, reverb etc.)

39 PHONO INPUT JACK [RCA JACK]
This input for turntables with MM cartridges only.

40 GROUND(GND) TERMINAL
The grounding lugs for turntables. Ground for phono circuit necessary to avoid hum.

HOW TO CHANGE THE FADER UNIT

Note

Use a plus driver fitting screw.
Caution: When you change any parts, do not loose the screws with  marking.

HOW TO REMOVE THE TOP PANEL

- ① Remove each fader knobs and 4 screws which fix the top panel.
- ② Remove the top panel.

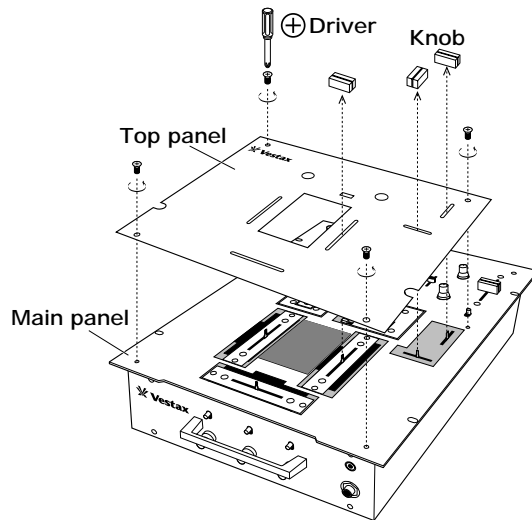

HOW TO CHANGE THE FADER UNIT

- ① Remove the two screws on the fader panel.
- ② Remove the fader unit from position in mixer.
- ③ Carefully remove the multi-cable connector from fader unit.
- ④ Attach multi-cable connector to new fader unit.
- ⑤ Position the fader unit carefully and secure with screws.

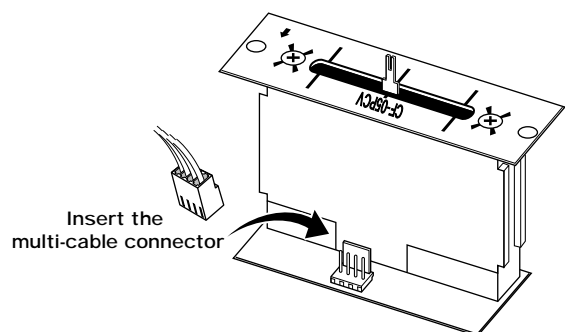
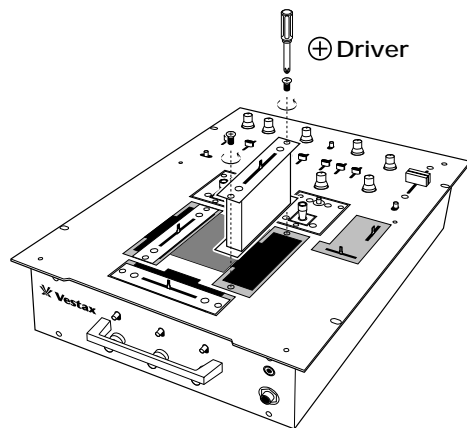

HOW TO CHANGE THE Q-STICK UNIT

- ① Remove the three screws on the Q-stick panel.
- ② Remove the Q-stick unit from position in mixer.
- ③ Carefully remove the multi-cable connector from Q-stick unit.
- ④ Attach multi-cable connector to new Q-stick unit.
- ⑤ Position the Q-stick carefully and secure with screws.

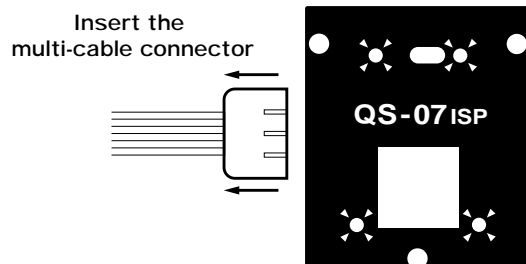

CONNECTION DIAGRAM

CONNECTION (EXAMPLE)

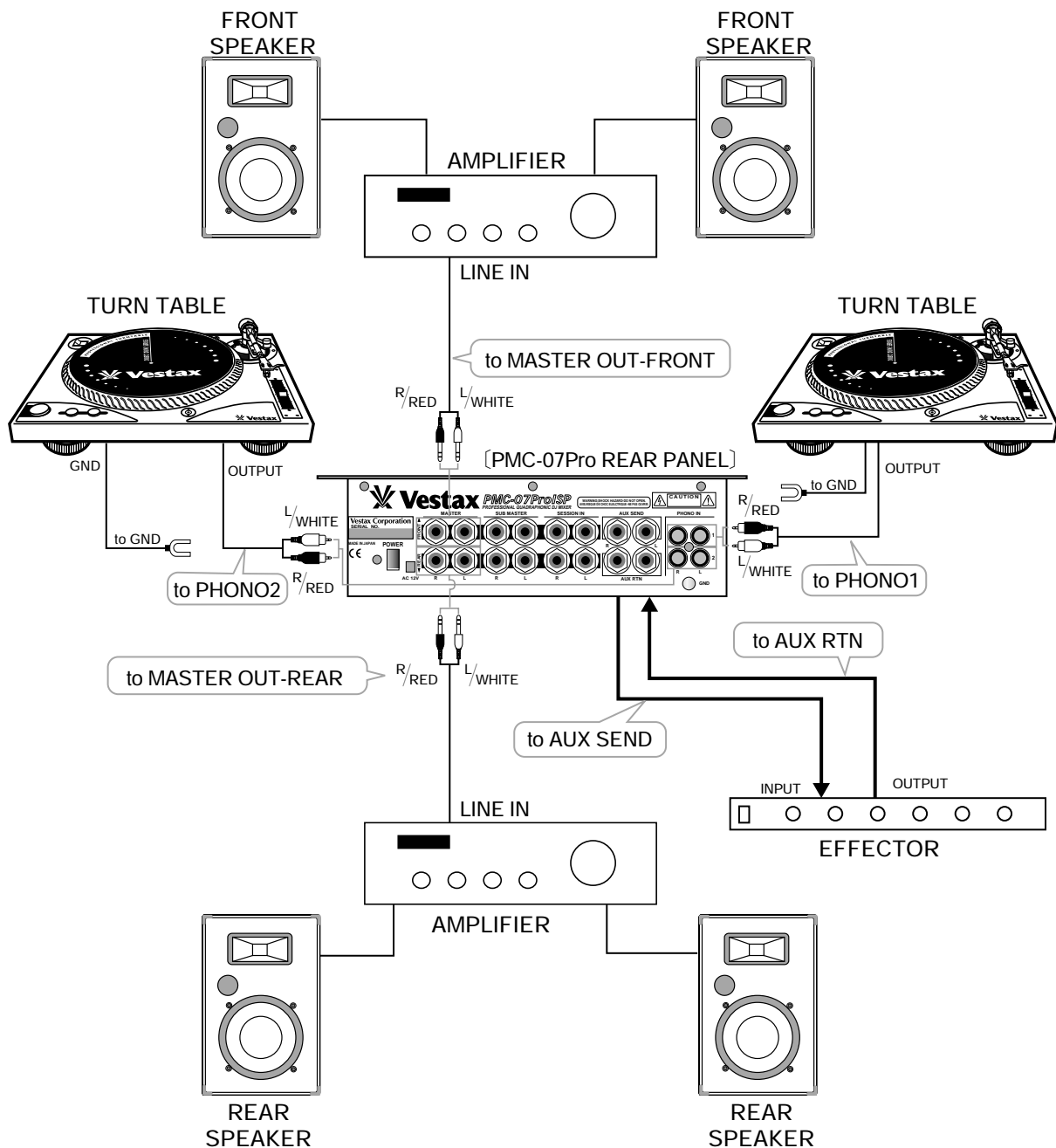

CHAIN CONNECTION DIAGRAM

CHAIN CONNECTION

When multiple mixers are used, the MASTER OUT of one mixer is connected to the SESSION IN of another. The volume is adjusted by the SESSION MIX VOLUME (①).

【EXAMPLE 1】 ~ Chain connection of more than one PMC-07ProISP ~

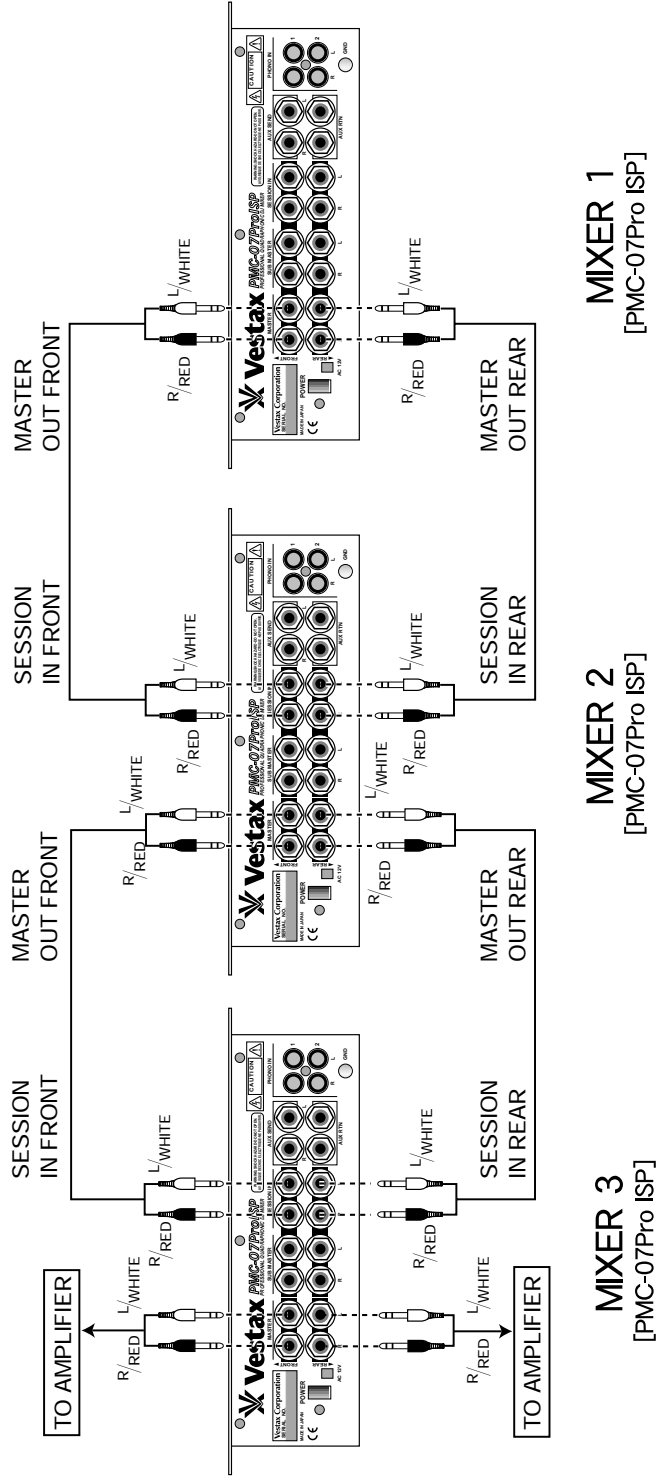

【EXAMPLE 2】 ~ Chain connection of PMC-07ProISP and other mixers ~

—Note

Chain connection with other mixers is restricted to FRONT SESSION IN (Do not use REAR SESSION IN).

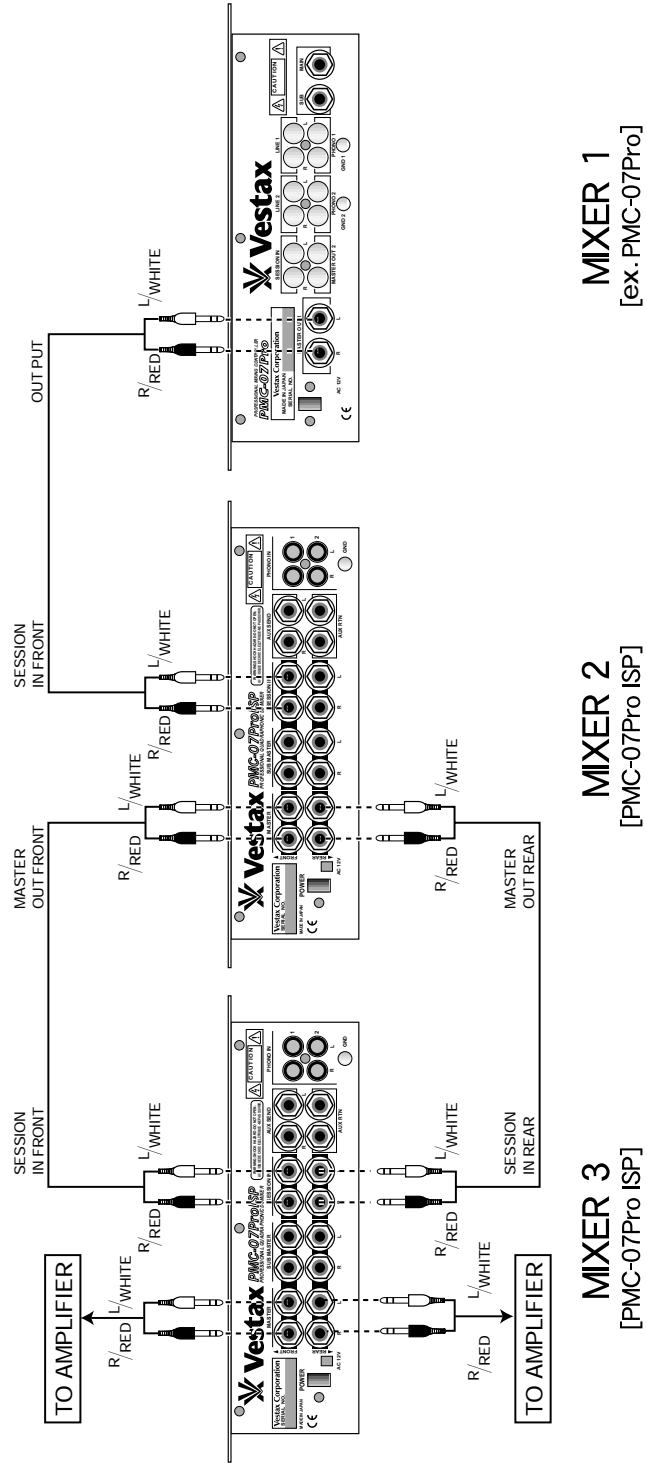

BLOCK DIAGRAM

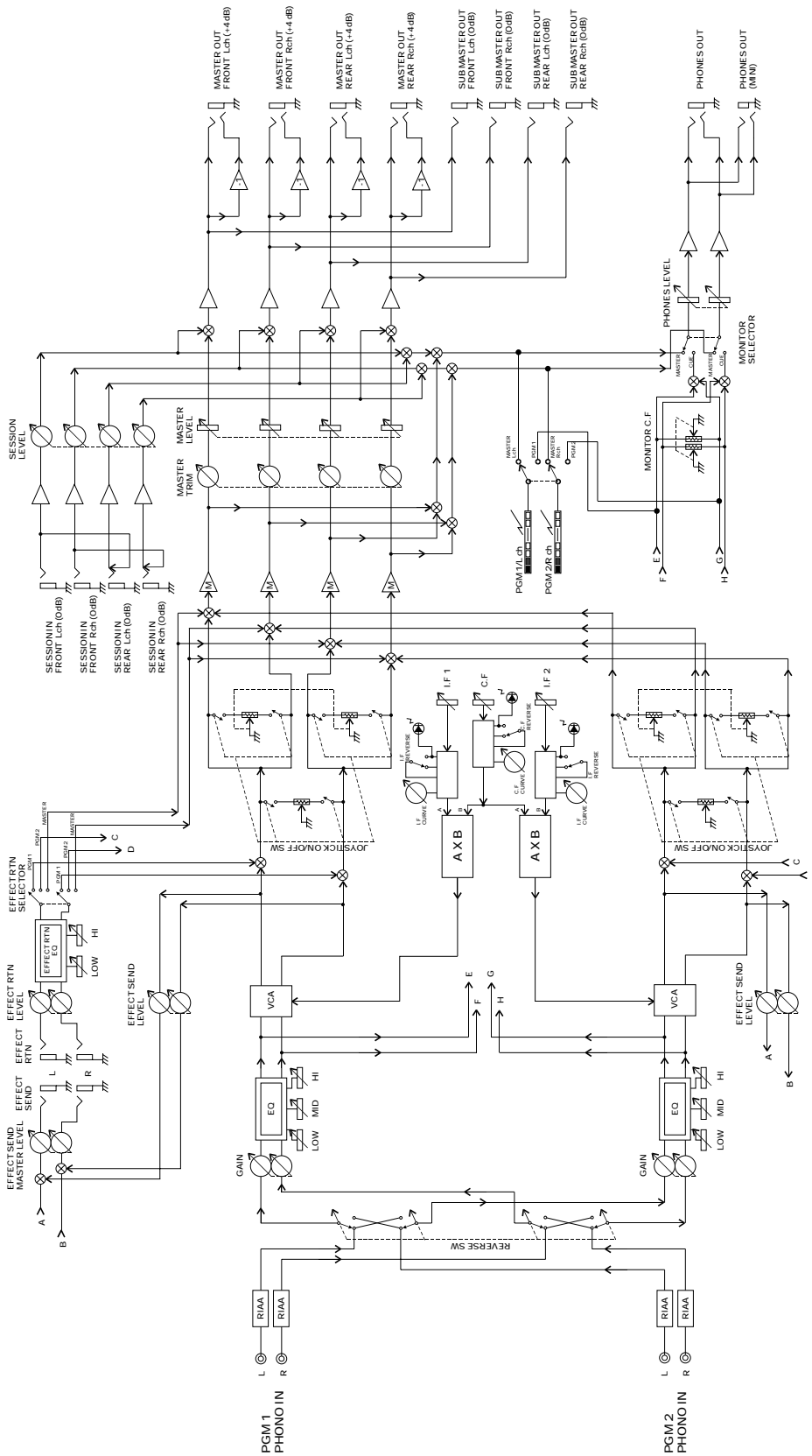

PMC-07Pro ISP BLOCK DIAGRAM

I.S.P model

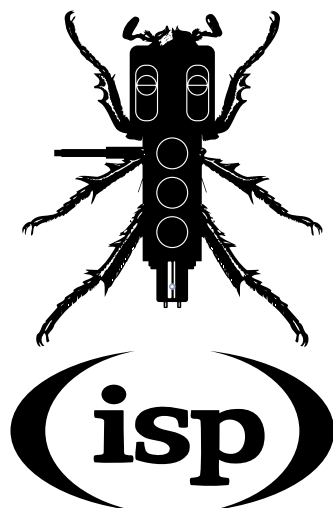

I.S.P...Invisibl Skratch Piklz.

World Champion performance DJ group I.S.P composed of Yogafrog, Q-Bert, Mixmaster Mike, D-Styles and Shortcut.

I.S.P reign as world champion of Turntablists and go on breaking new ground for DJ culture. The PMC-07ProISP continues in that tradition of top performance mixer and innovative ideas at ISP's request.

SPECIFICATIONS

		RATED INPUT	MAXIMUM INPUT	IMPEDANCE
INPUT SECTION	PHONO 1~2 L/R (RCA PIN JACK)	-46dBv	-22.4dBv	56k Ω
	SESSION IN L/R (1/4"PHONE JACK)	-6dBv	11.4dBv	48k Ω
	RETURN IN L/R (1/4"PHONE JACK)	-10dBv	14dBv	18k Ω
		RATED OUTPUT	MAXIMUM OUTPUT	LOAD IMPEDANCE
OUTPUT SECTION	MASTER L/R (1/4" TRS BALANCED)	0dBv	17.5dBv	$\geq 3k\Omega$
	SUB MASTER L/R (1/4" JACK UNBALANCED)	-6dBv	11.4dBv	$\geq 3k\Omega$
	SEND OUT L/R (1/4" JACK)	0dBv	14dBv	$\geq 3K\Omega$
	HEADPHONE (1/4"PHONE JACK)	(47 Ω load)	100mW	8~600 Ω
FREQUENCY RESPONSE		20Hz ~ 20 k Hz	POWER SUPPLY	
S/N RATIO		$\geq -65dB$	DIMENSIONS (W×H×D) mm	
		WEIGHT		3.5kg



JUNE.2000 PMC-07Pro ISPE

Vestax Corporation



Vestax Corporation 1-18-6 Wakabayashi, Setagaya-ku, Tokyo 154-0023 Japan
Telephone : 81-(0)3-3412-7011 Fax : 81-(0)3-3412-7013. www.vestax.jp

***This is to certify that the product subsequently referred to
was designed and manufactured in conformity with the
following EC directives;
89/336/EEC (EMC)
73/23/EEC (LVD)***

Model type : Professional Mixing Controller

Model Description : Professional DJ Mixer

Model Number : PMC-07ProISP

Applicable Standards : EN55013:1990+A12:1994+A13:1996 Limits and methods of measurement of radio disturbance characteristics of broadcast receivers and associated equipment (including amendments A12:1994 and A13:1996) (CISPR13:1975/Amdt1:1983, modified)
EN50082-1:1997 Electromagnetic compatibility-Generic immunity standard Part1:Residential, commercial and light industry

Date : Wednesday, December 19, 2001

Place of Issue : Vestax Corporation, 1-18-6 Wakabayashi, Setagaya-ku,
Tokyo 154-0023 Japan

**Manufacturers Authorized
Signature :**

Function of Signatory :

Masaaki Shiomi

Director

Free Manuals Download Website

<http://myh66.com>

<http://usermanuals.us>

<http://www.somanuals.com>

<http://www.4manuals.cc>

<http://www.manual-lib.com>

<http://www.404manual.com>

<http://www.luxmanual.com>

<http://aubethermostatmanual.com>

Golf course search by state

<http://golfingnear.com>

Email search by domain

<http://emailbydomain.com>

Auto manuals search

<http://auto.somanuals.com>

TV manuals search

<http://tv.somanuals.com>