

ZANUSSI

COFFEE MACHINE ZCOF636X

INSTRUCTION BOOK

UK

FOR YOUR PERSONAL SAFETY

This new appliance is easy to use. However, it is important to read the whole of this booklet before installing or using the appliance for the first time. This will enable you to obtain the best results from the appliance, to avoid incorrect use and to use the appliance safely and with respect for the environment.

DURING USE

- The appliance should be used by adults only. **Make sure that children do not touch the controls or play with the appliance.**
- It is dangerous to modify or to attempt to modify the characteristics of this product.
- **Keep the appliance clean at all times.**
- The external parts of the appliance heat up when the appliance is in use and remain hot for a certain length of time after it has been turned off. **Keep children away from the appliance until it has cooled down.**
- Always make sure that the appliance is **disconnected** from mains before carrying out maintenance work and before cleaning the appliance.
- **Never attempt to repair faults yourself.** Repairs carried out by unqualified persons may result in damage to the equipment or personal injury. Consult this booklet and if you do not find the information you are looking for **contact your nearest Service Centre.** This appliance should be serviced by authorised Technical Service Centres only. Always ask for original spare parts to be used.

INSTALLATION AND MAINTENANCE

- The appliance should be installed and connected to mains by **QUALIFIED PERSONNEL only.** Before carrying out any work on the appliance always make sure that it has been **DISCONNECTED** from the mains.
- Remove the appliance from the packaging, check it for damage and make sure that the power supply cable is in perfect condition. If any damage is apparent contact your retailer before using the appliance.
- **The Manufacturer declines all responsibility if the instructions in this book are not adhered to.**

RECOMMENDATIONS FOR SAFEGUARDING THE ENVIRONMENT

PACKAGING

- All packaging material is environmentally friendly and can be recycled. Please help safeguard the environment by disposing of packaging correctly using the waste disposal sites in your area.

AT THE END OF THE APPLIANCE'S LIFE

- When the appliance is to be scrapped, cut off the power supply cable.
- Check with your local Council or Environmental Health Office to see if there are facilities in your area for re-cycling the appliance.

This instruction booklet should be kept with the appliance for future reference. If the appliance is sold or transferred, make sure that the booklet is handed over to the new owners so that they are aware of the operating instructions and relative warnings.

INDEX

INFORMATION FOR THE USER

DESCRIPTION OF THE COFFEE MACHINE	PAGE 3
FIRST USE	PAGE 4
MAKING COFFEE	PAGE 5
HOT WATER	PAGE 6
STEAM	PAGE 6
RECIPES	PAGE 6
CLEANING & MAINTENANCE	PAGE 7
FAULTS	PAGE 10
TECHNICAL ASSISTANCE AND SPARE PARTS	PAGE 10
GUARANTEE CONDITIONS (UK)	PAGE 11
GUARANTEE AND SPARE PARTS (ONLY FOR BENELUX)	PAGE 12

INFORMATION FOR THE INSTALLER

TECHNICAL SPECIFICATIONS	PAGE 12
INSTALLATION	PAGE 12
WATER SUPPLY	PAGE 15
ELECTRICAL CONNECTION	PAGE 16
DRAWER	PAGE 17

EC This appliance conforms to directive BT 73/26

- concerning electrical safety standard EN 60335-1 (August 1995 – Safety of electrical appliances for domestic use and similar – General Standards) and EN 60335-2-15 (April 1996 – Special standards for liquid heating appliances).
- Directive EMC 89/336 concerning the following standards:
 - 55014-1
 - 55014-2
 - 61000-3-2
 - 61000-3-3

DESCRIPTION OF THE COFFEE MACHINE

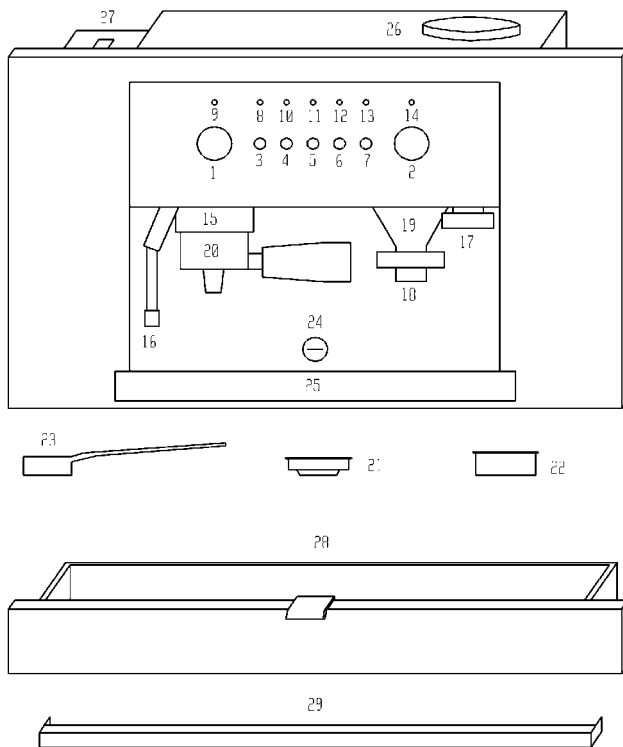

1. Steam knob
2. Grinding texture knob
3. On button
4. Coffee button
5. Hot water button
6. Steam button
7. Light button
8. Orange 'ON' indicator light
9. Red 'water temperature' indicator light
10. Green 'coffee' indicator light
11. Green 'water' indicator light
12. Green 'steam' indicator light
13. Green 'light on' indicator light
14. Green 'dispenser' indicator light
15. Filter holder ring nut
16. Steam spout
17. Coffee press
18. Grinder button
19. Coffee dispenser
20. Filter-holder
21. One-cup filter
22. Two-cup filter
23. Coffee scoop
24. Unit clamping lock
25. Drip tray
26. Coffee bean holder
27. Water tank
28. Drawer (optional)
29. Fixing bracket

FIRST USE

FILL THE WATER TANK

- **Water hardness:**
 - before filling the water tank make sure that the Brita filter is in place (see paragraph "Water supply").
 - if the appliance has not been used for a long time it is advisable to replace the water in the tank with fresh water and to empty the boiler by pressing the coffee button (ref.4) repeatedly.
- Open the unit clamping lock (ref.24) using the key supplied.
- Pull the coffee machine out of the unit on the telescopic runners.
- Fill the water tank (ref.27) located on the left-hand side of the appliance with approx. 2,5 litres of water.
- Push the machine back into the unit and fasten the unit clamping lock.

FILL THE COFFEE BEAN HOLDER

- Open the unit clamping lock (ref.24) using the key supplied.
- Pull the coffee machine out of the unit on the telescopic runners.
- Pour approx. 200g of coffee beans into the coffee bean holder (ref.26) on the right-hand side of the appliance.
- Push the machine back into the unit and fasten the unit clamping lock.

ADJUSTING THE TEXTURE OF GROUND COFFEE

- **The machine is supplied already calibrated to grind coffee beans to the ideal texture.**

- The texture of ground coffee can however be adjusted using the grinding texture knob (ref.2). Turn the knob clockwise for a finer texture and stronger coffee. Turn anticlockwise for a coarser grind and weaker coffee.

PROGRAMMING THE QUANTITY OF GROUND COFFEE

- **The machine is supplied already calibrated to supply the ideal measure of ground coffee for a cup of espresso.**
- However, the quantity of ground coffee supplied can be increased or decreased as follows:
 - place the filter holder (ref.20) with a one-cup filter (ref.21) below the coffee dispenser outlet (ref.19) and press the grinder button (ref.18) gently, do not release the button immediately. After approx. 10 seconds the grinder will start, when the quantity required is reached (recommended measure 7g corresponding to 6 seconds of grinding) simply release the button (ref.18) and the amount is automatically programmed.

PRELIMINARY START-UP

- **Only move the steam spout using the rubber handle.**
- Turn the coffee machine on by pressing the ON button (ref.3). The orange indicator light (ref.8) lights up to indicate that the machine is connected to the power supply.
- Turn the steam knob (ref.1) anti-clockwise.
- Press the hot water button (ref.5) and wait until all the air in the boiler is released through the steam spout (ref.16) and water starts coming through.
- The red indicator light (ref.9) illuminates at the same time to indicate that the water in the boiler is being heated. When the red indicator

light goes out the water has reached the required temperature for coffee making.

- Close the steam knob by turning clockwise (ref.1) and release the hot water button (ref.5).
- Allow any dispensed water to fall into the drip tray or a cup and discard.

ACCESSORIES SUPPLIED

- The coffee machine is supplied with a filter holder (ref.20) for one-cup filters (ref.21) and two-cup filters (ref.22).
If you are using pods, use the one-cup filter.
- A scoop (ref.23) is also supplied for measuring ground coffee (approx. 7.2g).

OPTIONAL ACCESSORIES

- A practical drawer with stainless steel front panel is available as an optional accessory, model **ZDRA 600 X**.
The drawer is divided into several compartments for various uses :
 - compartment for cups and saucers
 - basin for coffee dregs
 - compartment for machine accessories (filter, measure).
 - trayThe overall dimensions of the drawer are given on page 18.

MAKING COFFEE

MAKING COFFEE WITH COFFEE BEANS

- **Only use fresh good quality beans.**
- Place the filter holder (ref.20) beneath the dispenser (ref.19) and press the grinder button for at least one second and release (ref.18) this will automatically supply the correct one-cup

measure of ground coffee. For 2-cup filters (ref.22) repeat the operation.

- Press the ground coffee with the coffee press (ref.17) .
- Place the filter holder (ref.20) on the ring nut (15) making sure it locks into place: move the handle of the filter holder from left to right.
- Place one or two coffee cups below the spout of the filter holder with the correct nozzle fitted.
- When the red water temperature indicator light (ref.9) goes out, press the coffee button (ref.4).
- Once the required quantity of coffee has been dispensed press the coffee button (ref.4) a second time to stop the supply.
- Remove cup(s) from the machine.
- Remove the filter holder from the ring nut and empty the used ground coffee from it.

MAKING COFFEE WITH PODS (E.S.E. system)

- E.S.E stands for Easy Serving Espresso and is the International standard for making coffee using pods (a pod is a disposable single-use portion of roasted coffee) and a suitable coffee machine. The E.S.E. system is simple, practical and ecological since no special maintenance is required and nature is respected. Lastly, the system is clean as the special wrapping prevents spillage and is easily removed and disposed of after use.
- The machine is designed for use with ground coffee or pods: single-use disposable portions of roasted coffee.
- Place the pod in the filter holder.
- Position the filter holder (ref.20) on the ring nut (ref.15) making sure it locks into place: move the handle of the filter holder from left to right.
- Place a coffee cup below the spout of the filter holder.
- When the red water temperature indicator light (ref.9) goes out, press the coffee button (ref.4).

- Once the required quantity of coffee has been supplied, press the coffee button a second time to stop supply.
- Remove cup(s) from the machine.
- Take the filter holder off the ring nut and dispose of the used pod.

TIPS ON HOW TO PREPARE AN EXCELLENT ESPRESSO COFFEE

- To make good espresso coffee, the cleanliness of the machine and the right temperature are fundamental.
- Make sure that the filter, the filter holder and the ring nut are kept completely clean.
- Unless you are away for long periods, keep the machine turned on and the filter holder in the ring nut to keep it hot.
- Heat the coffee cups by filling them with hot water (press the coffee button). This also eliminates some of the water left in the boiler as well as heats the filter holder.
- When you have finished using the machine clean the filter holder by running the machine without coffee. This method eliminates any residues which could alter the flavour of the coffee the next time you use the machine.
- For an excellent espresso, let the machine run for 20-25 seconds. The time required depends on the texture of the ground coffee, the quantity of coffee used and how firmly the coffee is pressed. The machine is already calibrated to make good quality coffee. If necessary the grinding texture and the quantity of ground coffee dosed can be adjusted (see paragraph "First Use") to obtain the required strength and flavour.

HOT WATER

- Place the coffee cup below the steam spout (ref.16), using the handle to move the spout so as not to cause burns.

- Turn the steam knob (ref.1) anti-clockwise.
- Press the hot water button (ref.5). Release the button when you have the required amount of hot water and close the steam knob (ref.1).

STEAM

- Steam is used to make cappuccino coffee (see chapter "Recipes").
- Keep the steam button (ref.6) pressed and wait until the red indicator light (ref.9) goes out.
- Place a receptacle beneath the steam spout and slowly turn the steam knob (ref.1) anti-clockwise.
- When you have finished with the steam close the steam knob by turning anti-clockwise (ref.1) and press the steam button (ref.6).
- If the steam comes into contact with a cool surface on the surrounding furniture or outside of the appliance, e.g. a trim, it will condense and produce water droplets. This is quite normal and not caused by a fault with the machine. To prevent discolouration, regularly wipe away condensation from surfaces.

RECIPES

ITALIAN CAPPUCCINO

This is a normal espresso coffee with steam-heated milk that gives the coffee a milder flavour and a rich, frothy topping. Serve in a large cup.

Pour cold milk into a tall jug and heat it using the steam spout if your machine has one. Add only the froth to the espresso coffee, to do this either tilt the jug slightly rocking it backwards and forwards while you pour or use a spoon to scoop off the froth.

You can also add a dusting of cocoa powder to taste.

VIENNESE CAPPUCCINO

This variation is the result of age-old Austrian tradition.

Prepare a 'long' espresso by letting the machine run for longer than usual (30-35 seconds), add hot milk followed by whipped cream. Serve in a medium-sized cup (midway between an espresso cup and a cappuccino cup).

Decorate with flakes of chocolate.

COLD ESPRESSO SHAKE

Frothy and extremely refreshing, this makes a pleasant drink on hot days.

Prepare an espresso coffee, add sugar and pour into a cocktail shaker with large ice cubes. Shake for a few seconds.

Serve in a tumbler or flûte.

IRISH COFFEE

Any energy-giving tonic.

Warm a tall glass and mix eight parts of hot coffee with one part whisky and brown sugar.

Gently pour freshly whipped cream over the back of a spoon so that it floats on the coffee: the result is a layer of cool white cream on top of the hot dark coffee.

MEXICAN COFFEE

Intense and exotic.

Mix together a portion of double cream, half a teaspoon of cinnamon, a pinch of nutmeg and sugar in a small cup and beat until it becomes frothy.

Place a teaspoon of chocolate syrup, a pinch of cinnamon and the coffee into a medium-sized cup and blend together.

Top with a teaspoon of vanilla-flavoured cream.

CAPPUCCINO ICE-CREAM

Heat 2 cups of espresso coffee, $\frac{3}{4}$ cup of single cream and $\frac{1}{2}$ cup sugar in a pan and bring to boiling point.

Leave to cool before placing in the freezer for 4-5 hours.

Move to the refrigerator $\frac{1}{2}$ hour before serving.

Serve two-three balls of the ice-cream in a small bowl and decorate with roasted coffee beans.

CLEANING AND MAINTENANCE

EXTERNAL PARTS

- Clean all the external parts of the machine with a soft cloth wrung out in warm water with a little washing up liquid. Do not use harsh detergents.
- Do not clean steel surfaces with abrasive pads or sponges or a high pressure washer.
- Use a non-abrasive stainless steel cleaner for more stubborn marks.
- Dry thoroughly using a soft cloth.

DRIP TRAY

- Empty the drip tray (ref.25) regularly to avoid the overflow of liquids which could soil and damage the cupboards below the machine.
- Both the drip tray and the grid are dish-washer proof.

FILTER/FILTER-HOLDER/RING NUT

- The filters (ref. 21 and 22), the filter holder (ref.20) and the ring nut (ref.15) should be kept clean at all times. Any residual coffee may alter the taste of the next coffee you make.

- Put the filter holder and the filter in the dishwasher every 2 months.

WATER TANK

- If left unused for long periods it is advisable to replace the water in the tank with fresh water and to empty the boiler by pressing the coffee button (ref.4) repeatedly.
- Clean the water tank (ref.27) periodically to remove any lime-scale.
- The water tank is dish-washer safe.
- If Brita decalcifying filters are used it is advisable to replace the filter every 2000 espresso coffees or at least every two months.
- Ensure that the plastic tube is placed inside the water tank so the water is fed into the machine.

BOILER CLEANING FREQUENCY

- Like any other appliance that uses water, it is perfectly normal for lime-scale to form inside the boiler of the coffee machine.
- It is advisable to clean the boiler every six months as follows:
 - Fill the tank with 1.5l water and add half a glass of vinegar or citric acid.
 - Press the coffee button repeatedly so that the water/vinegar solution comes through a little at a time until the tank is empty.
 - Repeat the operation until clean water comes through (with no trace of lime-scale).
 - Fill the tank with cold water and again press the coffee button repeatedly to rinse the boiler.
- The machine is now ready for use.

CHANGING THE LIGHT BULB

- If the light bulb fails, ensure that the light housing is cool before replacing the bulb. To replace the bulb proceed as follows:
 - Disconnect the machine from the electricity supply.

- Pull down the glass retaining ring and glass.
- Pull out the bulb and replace with one of the same characteristics making sure that the glass of the new bulb is not touched by hand.
- Carefully wipe the new bulb with a soft cloth.
- Refit the glass and glass retaining ring and reconnect the machine to the electricity supply. The bulb is a 20 watt, 12 volt halogen bulb with a bi-pin fitting.

SOMETHING NOT WORKING

Certain problems are due to lack of simple maintenance or oversights, which can be solved easily without calling out an engineer. Before contacting your local Service Centre, please carry out the checks listed below.

If the machine does not operate, check that:

- The machine is connected to the electricity supply.
- The water tank is not empty.

If the power supply cable is damaged or for any other maintenance operation please contact your local Zanussi Service Centre.

TECHNICAL ASSISTANCE AND SPARE PARTS

If the problem persists after carrying out the check-ups indicated in the previous chapter, contact your nearest authorised Technical Assistance centre. Always describe the fault and give the model (**Mod.**), product number (**Prod. no.**) and serial number (**Ser. No.**) of the appliance which are indicated on the identification plate of the coffee machine.

The plate is located on the external right-hand side of the machine and is clearly visible when the machine is opened.

SERVICE AND SPARE PARTS (UK)

In the event of your appliance requiring service, or if you wish to purchase spare parts, please contact your local **Zanussi Service Force Centre** by telephoning:

08705 929929

Your telephone call will be automatically routed to the Service Force Centre covering your post code area. The addresses are listed on the following pages.

Before calling out an engineer, please ensure you have read the details under the heading "FAULTS".

When you contact the Service Force Centre you will need to give the following details:

1. Your name, address and post code
2. Your telephone number
3. Clear and concise details of the fault
4. The model and serial number of the appliance.
5. The purchase date

CUSTOMER CARE DEPARTMENT **(UK)**

For general enquiries concerning your Zanussi appliance or for further information on Zanussi products, please contact our Customer Care Department by letter or telephone at the address below or visit our website at www.zanussi.co.uk

Customer Care Department

Zanussi
55-77 High Street
Slough
Berkshire
SL1 1DZ
08705 727727 (*)

* calls to this number may be recorded for training purposes.

GUARANTEE **CONDITIONS (UK)**

ZANUSSI GUARANTEE CONDITIONS

We, Zanussi, undertake that if, within 24 months of the date of the purchase, this Zanussi appliance or any part thereof is proved to be defective by any reason only of faulty workmanship or materials, we will, at our option, repair or replace the same **FREE OF ANY CHARGE** for labour, materials or carriage on condition that:

* The appliance has been correctly installed and used only on the gas and electricity supply stated on the rating plate.

* The appliance has been used for normal domestic purpose only, and in accordance with the manufacturer's instructions.

* The appliance has not been serviced, maintained, repaired, taken apart or tampered with by any person not authorised by us.

* All service work under this guarantee must be undertaken by a Zanussi Service Centre.

* Any appliance or defective part replaced shall become the Company's property.

* This guarantee is in addition to your statutory and other legal rights.

Home visits are made between 8.30am and 5.30pm Monday to Friday. Visits may be available outside these hours, in which case a premium will be charged.

EXCLUSIONS

This guarantee does not cover:

* Damage or calls resulting from transportation, improper use or neglect, the replacement of any light bulbs or removable parts of glass or plastic.

* Costs incurred for calls to put right an appliance which is improperly installed or calls to appliance outside the United Kingdom.

* Appliances found to be in use within a commercial or similar environment, plus those which are the subject to rental agreements.

* Products of Zanussi manufacture which are not marketed by Zanussi.

EUROPEAN GUARANTEE

If you should move to another country within Europe then your guarantee moves with you to your new home subject to the following qualifications:

* The guarantee starts from the date you first purchased your product.

* The guarantee is for the same period and to the same extent for labour and parts as exist in the new country of use for this brand or range of products.

* This guarantee relates to you and cannot be transferred to another user.

* Your new home is within the European Community (EC) or European Free Trade Area.

* The product is installed and used in accordance with our instructions and is only used domestically, i.e. a normal household

* The product is installed taking into account regulations in your new country.

Before you move, please contact your nearest Customer Care centre, listed below, to give them details of your new home. They will then ensure that the local Service Organisation is aware of your move and able to look after you and your appliances.

France	Senlis	+33 (0)3 44 62 29 99
Germany	Nürnberg	+49 (0)911 323 2600
Italy	Pordenone	+39 (0)1678 47053
Sweden	Stockholm	+46 (0)8 738 79 50
UK	Slough	+44 (0)1753 219897

GUARANTEE AND SPARE PARTS (ONLY FOR BENELUX)

When calling for repairs during the period of guarantee of the appliance, the original invoice or receipt must be shown or sent together with the appliance to be repaired.

GENERAL CONDITIONS OF GUARANTEE

1 The manufacturer guarantees the appliance indicated on the relative invoice for a period of one year from the date of purchase. In case of a fault during this period if caused by a defect in materials and/or construction, the client is entitled to repair free of charge.

1a Concerning vacuum cleaners for domestic use, the total period of guarantee is two years. Accessories are subject to a direct usage, consequently these articles are excluded from the guarantee.

2 The manufacturer guarantees technical assistance and repairs for one year. Spare parts fitted during repair are also covered by a one year guarantee from the date of repair. In case of fault during this period, as a direct result of the repair work carried out or caused by the new parts fitted on such occasion, the client is entitled to repair free of charge. The execution of repairs does not prolong the total period of guarantee covering the appliance.

3 Technical Assistance At Domicile Will Be Provided Only For Large Apparatus Which Are Difficult To Transport Such As: Washing Machines, Spin-Driers, Dishwashers, Refrigerators, Freezers (Vertical Or Horizontal), Ovens, Cookers And Built-In Appliances.

3a The above-mentioned conditions are also valid for refrigerators for caravans on condition that they are situated within the national boundaries and are accessible by roads open to traffic. Furthermore, at the time of the intervention the appliance and its owner, or the person so authorized, must be present at the place agreed upon for the intervention.

4 If, in the opinion of the manufacturer, the appliance as described in point 3 must be transported to a Technical Assistance laboratory, the transportation will be carried out as established

by the manufacturer, at his expense and under his responsibility.

5 All appliances not mentioned under points 3 and 3a, including appliances having the same functional characteristics but whose transport is easy, must be sent to the Technical Assistance or taken to them. Throughout the period of guarantee the cost of return transportation will be taken care by the manufacturer.

6 If during the period of guarantee a disfunction occurs due to a defect which cannot be repaired, the appliance will be replaced free of charge.

EXTENSION OF THE GUARANTEE

7 For motorcompressors of refrigerators/ freezers (excluding the starting device and thermal interrupter) a decreasing guarantee of 20% per year for a period of five years from the date of purchase of the appliance indicated on the relative invoice with repairs free of charge throughout the entire period under guarantee. On completion of the total period of guarantee the cost of travel, workmanship and eventual spare parts will be at the expense of the client.

EXCLUSION FROM GUARANTEE

8 The free execution of work for the repair and/ or substitution as set out above will not apply if:

- The purchase invoice or receipt indicating the date of purchase and the identification of the appliance cannot be presented or was not sent with the appliance to be repaired;
- The appliance is used for purposes other than those of the domestic nature for which it was made;
- The appliance was not installed, handled or used in conformity with the indications in the instruction manual or in the modalities for use;
- The appliance has been repaired or modified incorrectly by unqualified personnel.

8a If the appliance has been built-in, underinserted, suspended or installed in such a way that the time required to move it and put it back in position exceeds thirty minutes in total, the extra expenditures occurred will be billed to the owner of the appliance.

8b In case of deterioration due to an irregular installation carried out in agreement with the owner

of the appliance, the manufacturer and the technical assistance decline all responsibility.

8c Damage such as scratches, knocks or breakage of movable or dismountable units which were not notified to the manufacturer at the time of delivery are not covered by the guarantee.

IMPORTANT NOTICE

This appliance has been made to be safe. Inadequate repairs can nonetheless compromise this safety. To avoid such problems and to prevent any eventual damage we advise you to have repairs carried out exclusively by qualified personnel. We advise you to have repairs or maintenance carried out by the retailer or the ELECTROLUX SERVICE and to request only original spare parts.

BELGIUM

Bergensesteenweg 719 / B - 1520 Halle (Lembeek)

Repairing to customer's house:

Tel.: 02-3630444

Fax.: 02-3630400

Spare parts:

Tel.: 02-3630555

Fax.: 02-3630500

LUXEMBOURG

7, Rue de Bitbourg / L-1273 Luxembourg-Hamm

Customer care:

Tel.: 42 43 11

Fax: 42 43 13 60

TECHNICAL SPECIFICATIONS

- Width 594 mm
- Depth 280 mm
- Height 357 mm
- Tank capacity 2,5 litres
- Net weight 17 kg
- Gross weight 19 kg
- Power supply voltage 230-240 V
- Heater power consumption 1000 W
- Pump power consumption 50 W
- Light bulb power consumption 20 W
- Total power consumption 1070W
- Working pressure 12 bar
- Fuse 13 A

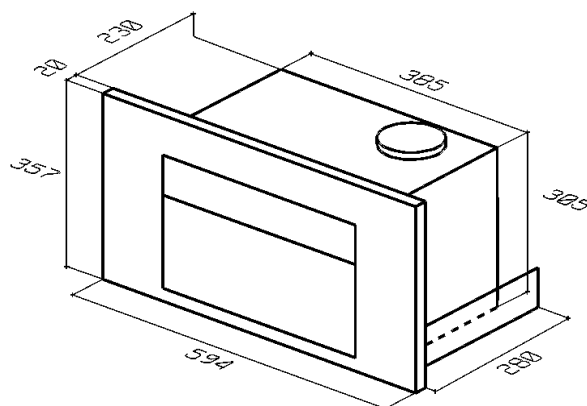

INSTALLATION

INSTALLING IN MODULAR UNITS

This appliance must be installed by a competent person.

For the appliance to work efficiently when installed in a modular unit, the unit must have suitable characteristics.

In conformity with safety standards, the appliance must be installed correctly in order to guarantee protection against contact between electrical parts and parts with purely functional insulation.

All parts that act as guards, even the reveal side panel for appliances installed at one extremity of a combination, must be firmly secured so that they cannot be removed without the use of tools.

It is advisable to avoid installing the appliance immediately next to refrigerators or freezers since the heat produced by the appliance could affect their efficiency.

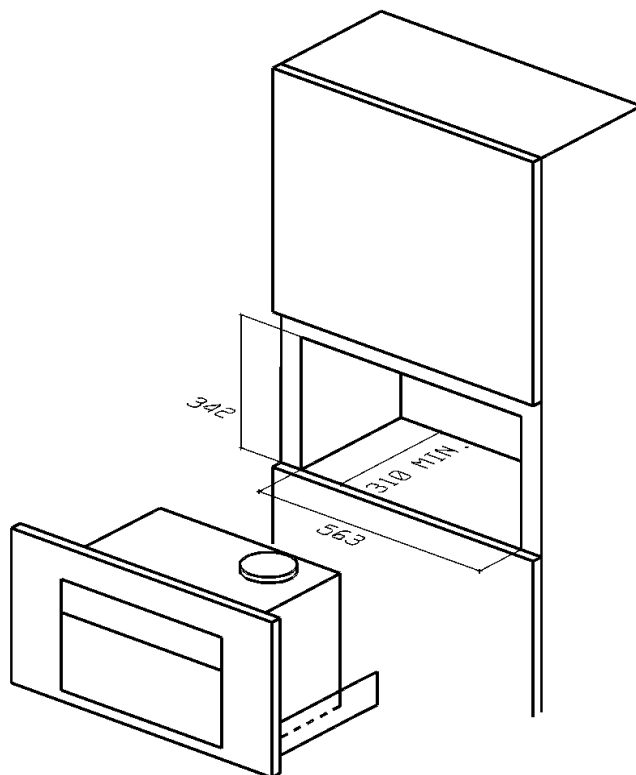

- **Warning:**

- Connect the power supply cable of suitable dimensions before securing the power supply unit.
- Assemble the runners on the sides of the machine (using the screws supplied) as shown in fig.1.
- Fasten the telescopic runner supports (RH and LH) using three wood screws (fig.2) and taking care to follow the measurements shown in fig.2.
- Make a slot in the bottom of the open compartment following the measurements given in fig.2.
- If the compartment does not have a shelf for the machine to rest on, assemble the machine fixing bracket (ref.29) as shown in fig.4. Place screw 1 in the slot of the bracket and adjust the position before locking in place using screw 2.
- Fasten the power supply unit (fig.3) to the back of the appliance in the top left-hand corner using two wood screws as shown in fig.2.

Fig. 2

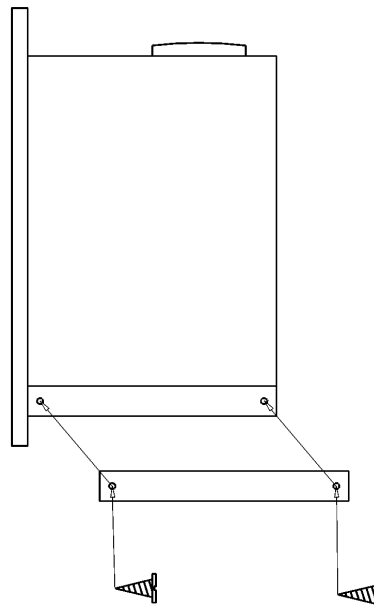

Fig. 1

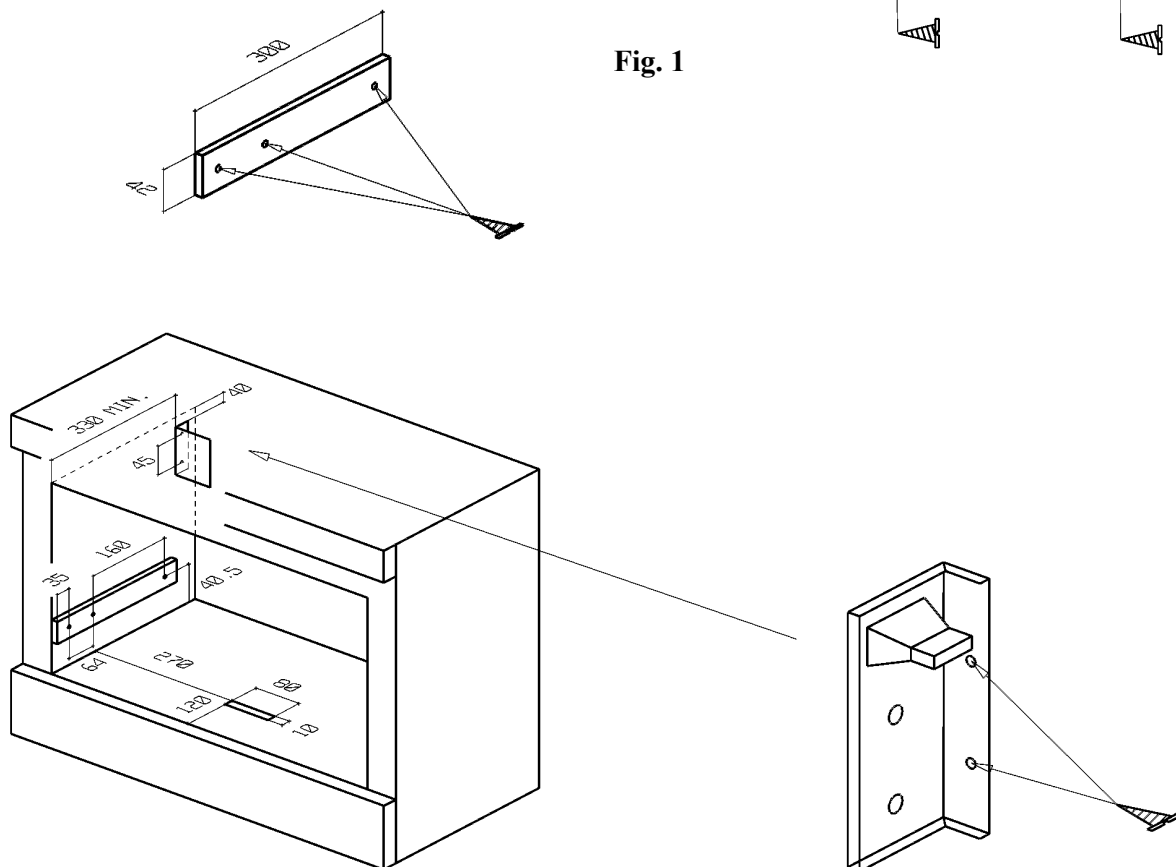

Fig. 3

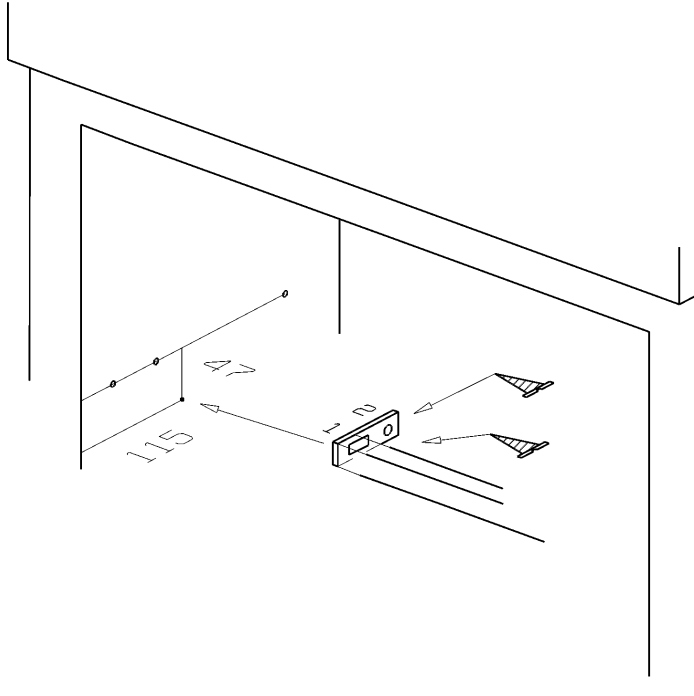
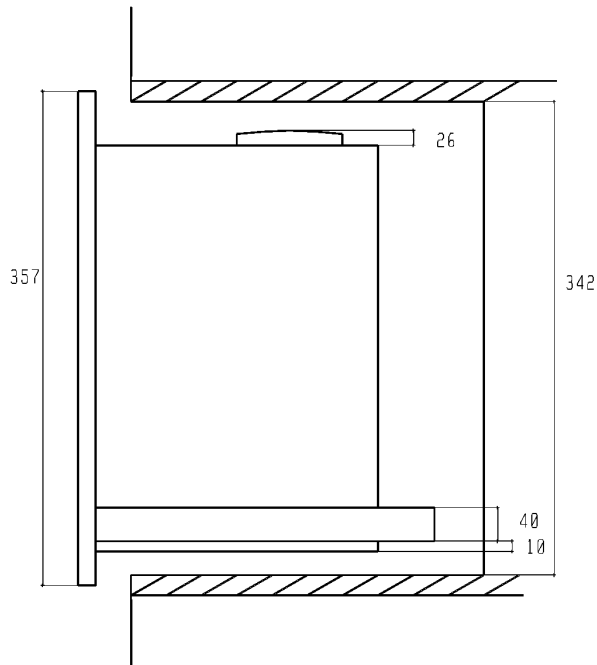

Fig. 4

- Assemble the telescopic runners of the coffee machine in the supports fixed to the inside of the unit; push the runners in until they reach the limit stop and secure the runners (fig.5).

Fig. 5



WATER SUPPLY

- Take the lid off the water tank (ref.27) and take out the Brita filter.
- Take the filter out of the packaging and soak it in cold water for half an hour before fitting it firmly into the hole in the tank (fig.6).
- Place the water hose in the relative channel (fig.7) and push it down until it reaches the bottom of the tank (fig.8).
- Fill the tank with cold water.
- **Warning:** only fill the tank with cold drinking water only: do not pour milk or any other liquid into the tank!
- The Brita filter is available at shops selling household appliances, or your local Service Centre.

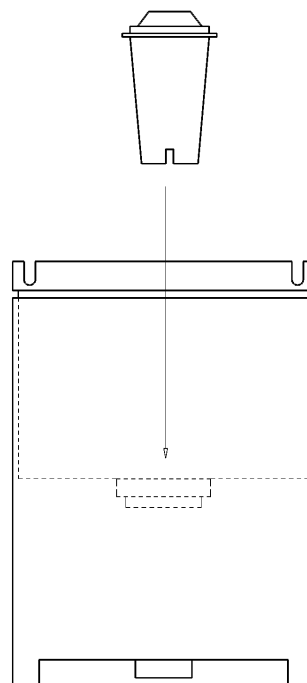

Fig. 6

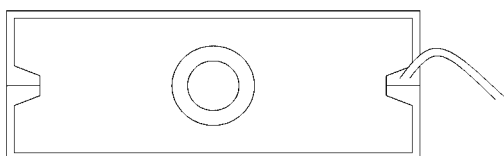

Fig. 7

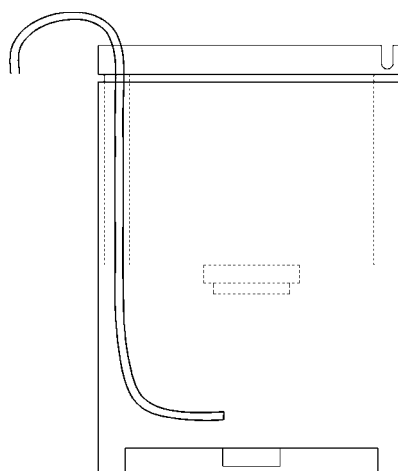

Fig. 8

ELECTRICAL CONNECTION

- Make sure that the electric circuit is suitably earthed.
- Connect the power cable supplied to the connector on the back of the appliance, plug the connector into the power supply unit on the back of the post (fig.3) where you will find the terminal board (fig.9) set to operate at a supply voltage of 230V monophas.
- Make sure that a circuit breaker is installed in the electrical circuit of the building to disconnect it from mains and that contacts are at least 3mm apart.
- **WARNING: the supplier disclaims all responsibility in the case of non-observance of the above rule.**

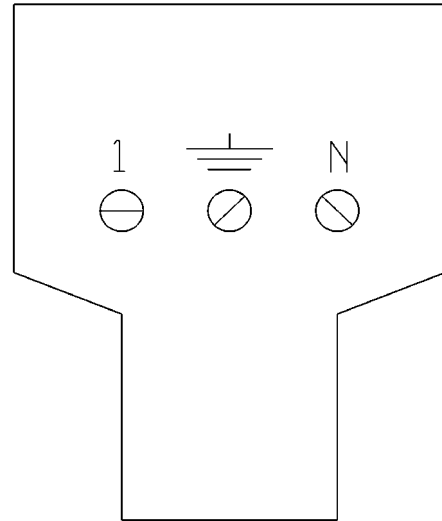

Fig. 9

DRAWER

The required dimensions of the compartment for installing the machine with the drawer are given in fig. 10 and 11.

Fig.10

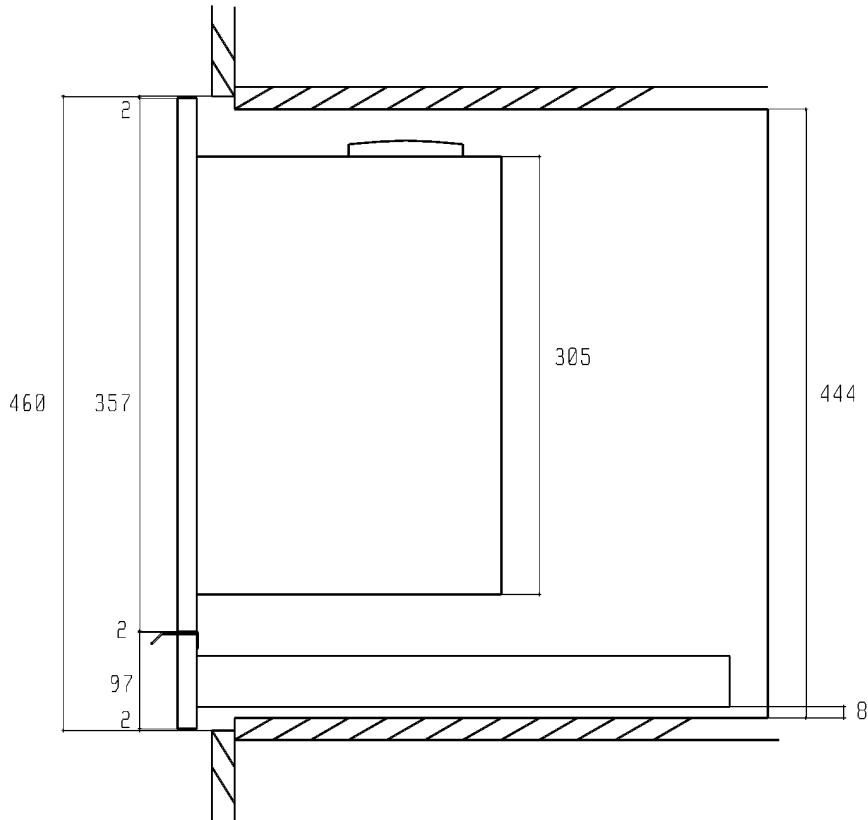
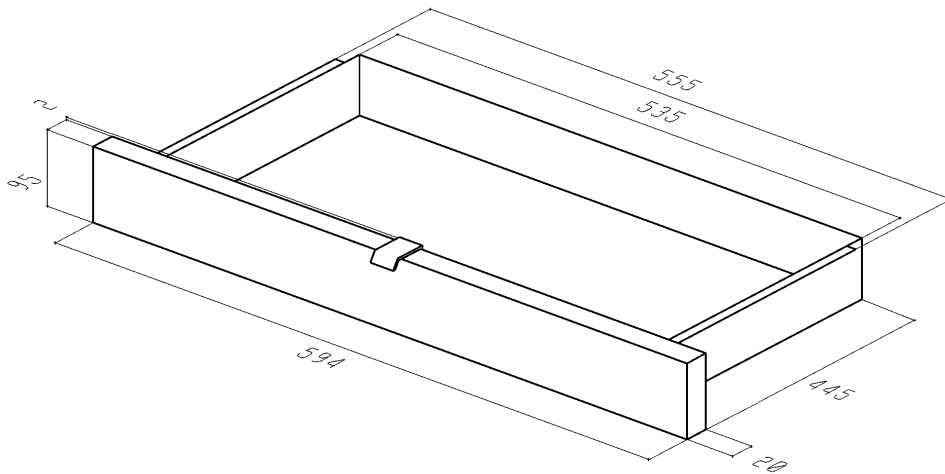

Fig.11



ENGLISH

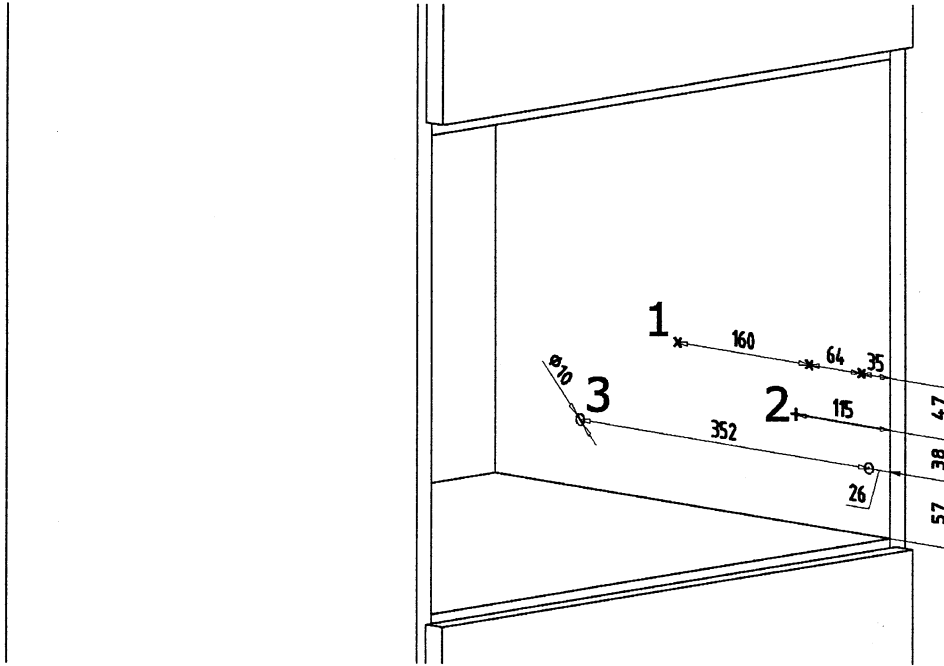

Fig. 1

Cabinet drilling diagram:

- position 1:** points for fixing the telescopic slides of the espresso machine.
- position 2:** first fixing point of the bracket for blocking the espresso machine.
- position 3:** holes (Ø10) for the plugs fixing the drawer's slides.

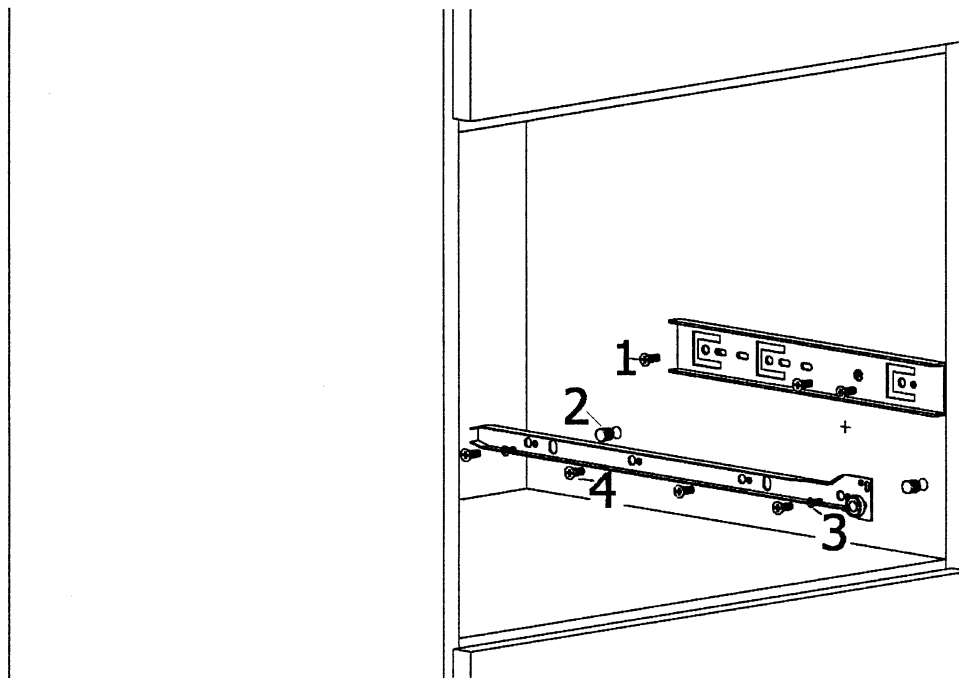

Fig. 2

Assemble the slide of the machine fixing it with 3 self-threading screws Ø 3.5x15 (1) of the equipment. Assemble the slide of the machine using the two plugs (2) and the two screws M4 (3) of the equipment; once inserted the slide in the column, complete the assembling operations tightening the 4 self-threading screws Ø 3.5x15 (4) of the equipment, as shown in fig. 2.

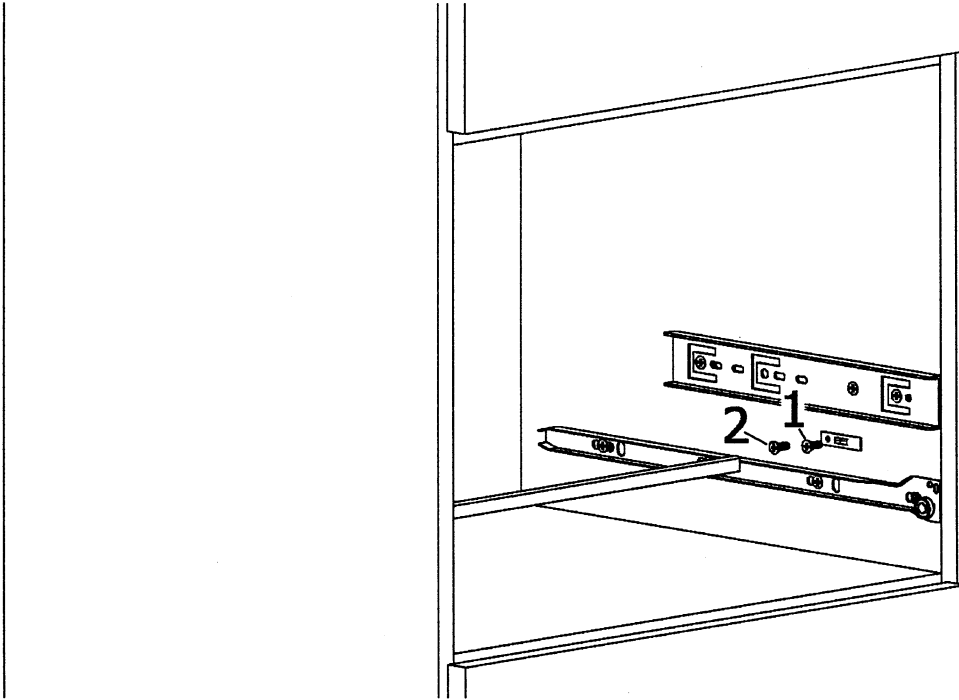

Fig. 3

Assemble the bracket for blocking the machine by using only one of the two self-threading screws \varnothing 3.5x15 of the equipment, that is the screw appearing in the position 1, as shown in fig. 3.

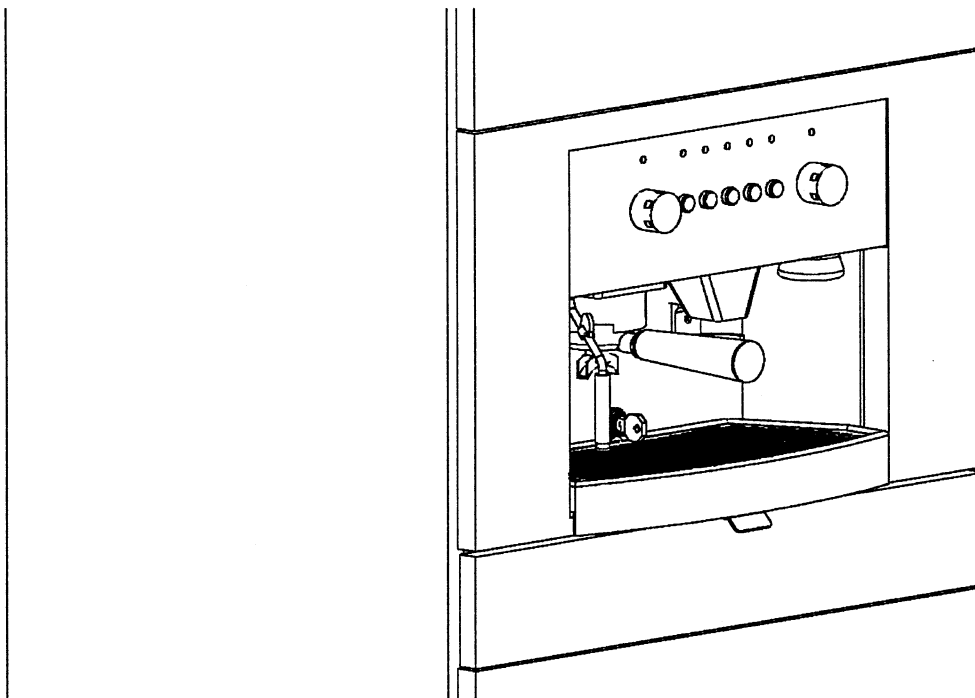
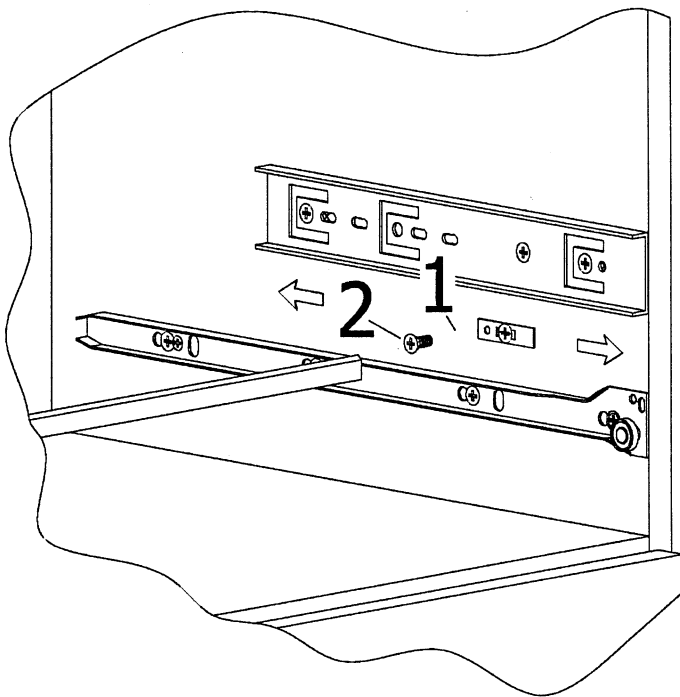

Fig. 4

After fixing both the slide and the bracket on the sides of the cabinet, insert the drawer as shown in fig. 4.

ADJUSTING THE POSITION OF THE ESPRESSO MACHINE

Remove the drawer and check the bracket's position.



When necessary, adjust the bracket's position for blocking the espresso machine, as shown in fig. 5, and complete the assembling operation tightening the screw of the position 2.

Fig. 5

ADJUSTING THE FRONTAL PANEL

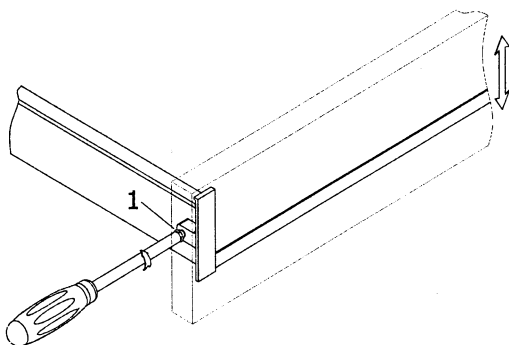

Fig. 6

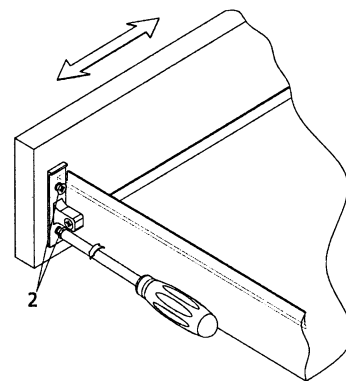

Fig. 7

VERTICAL ADJUSTMENT

Carry out the vertical adjustment of the frontal panel loosening the screw (1) of fig. 6, then adjust the position of the frontal panel and then tighten the screw (1) again.

HORIZONTAL ADJUSTMENT

Carry out the horizontal adjustment of the frontal panel loosening the two screws (2) of fig. 7; once adjusted the position of the frontal panel tighten the two screws (2) again.

OVERALL DIMENSIONS

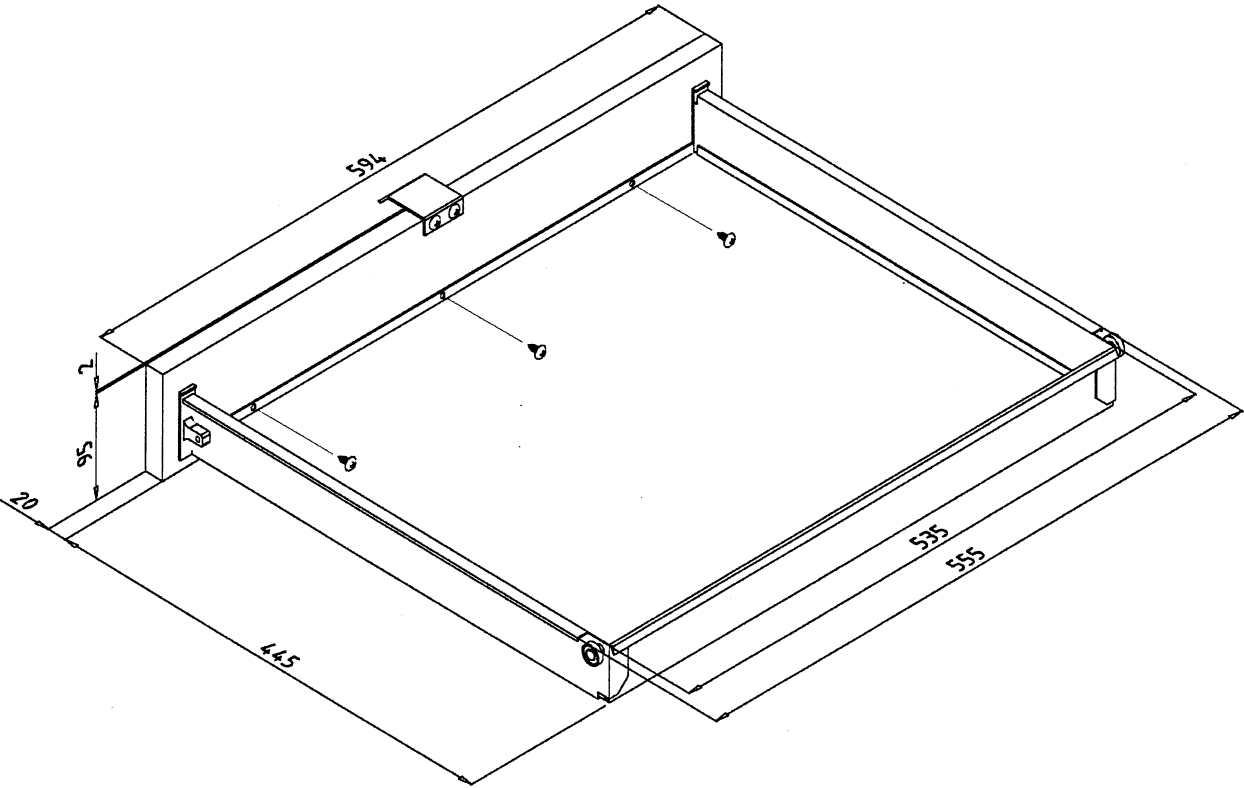
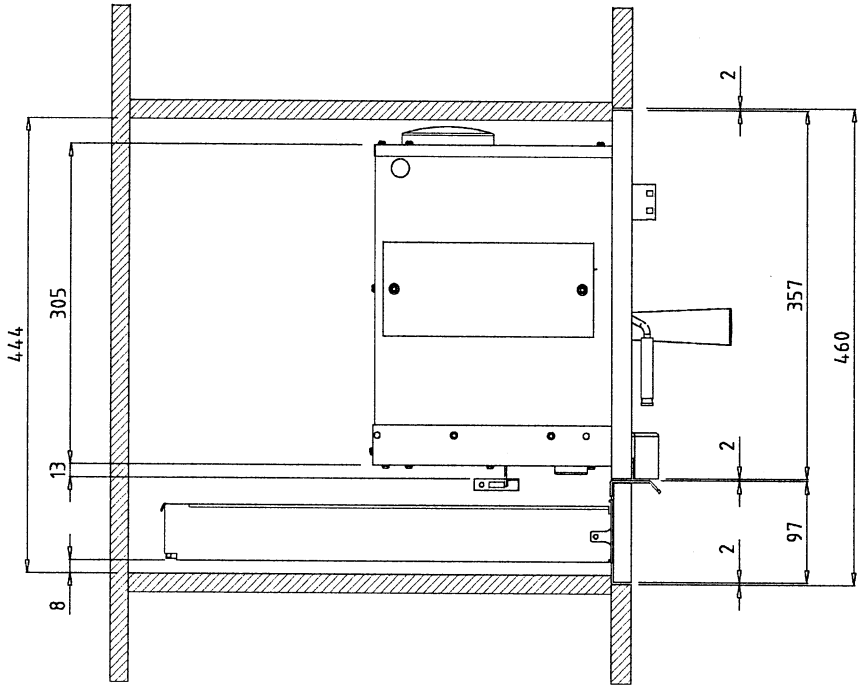

Fig. 8

Once adjusted the position of the frontal panel, complete the assembly tightening the three self-threading screws $\varnothing 4.75 \times 13$ (3), of the equipment, as shown in fig. 8.

 **From the Electrolux Group. The world's No.1 choice.**

The Electrolux Group is the world's largest producer of powered appliances for kitchen, cleaning and outdoor use. More than 55 million Electrolux Group products (such as refrigerators, cookers, vacuum cleaners, chain saws and lawn mowers) are sold each year to a value of approx. 14 billion USD in more than 150 countries around the world.

Free Manuals Download Website

<http://myh66.com>

<http://usermanuals.us>

<http://www.somanuals.com>

<http://www.4manuals.cc>

<http://www.manual-lib.com>

<http://www.404manual.com>

<http://www.luxmanual.com>

<http://aubethermostatmanual.com>

Golf course search by state

<http://golfingnear.com>

Email search by domain

<http://emailbydomain.com>

Auto manuals search

<http://auto.somanuals.com>

TV manuals search

<http://tv.somanuals.com>